

Safety Light Curtain

F3SJ-A

High-functional ADVANCED type supports finger protection and special applications.

- Detection capability supports finger protection.
- Equipped with wide variety of functions such as partial muting and blanking functions.
- The system status can be checked with PC tool.

Related information

Function List : Page 99 to 100
 Safety Precautions : Page 101
 Precautions on Safety : Page 102 to 107

Ordering Information

Main Units

Safety Light Curtain

Application	Detection capability	Beam gap	Operating range	Protective height (mm)	Model	
					PNP output	NPN output
Finger protection	Dia. 14 mm	9 mm	0.2 to 9 m	245 to 1,271	F3SJ-A□□□□P14 *2	F3SJ-A□□□□N14
Hand protection	Dia. 20 mm	15 mm	0.2 to 9 m	245 to 1,505	F3SJ-A□□□□P20 *2	F3SJ-A□□□□N20
Hand/arm protection	Dia. 30 mm	25 mm	0.2 to 9 m	245 to 1,620	F3SJ-A□□□□P30 *1	F3SJ-A□□□□N30
			0.2 to 7 m	1,745 to 2,495		
Leg/body protection, presence detection	Dia. 55 mm	50 mm	0.2 to 9 m	270 to 1,570	F3SJ-A□□□□P55 *1	F3SJ-A□□□□N55
			0.2 to 7 m	1,670 to 2,470		

Note: Connection cables are not included in the products. You must purchase optional connector cable.

*1. Models with S-mark certification have an "-S" at the end of the model number.

Example: F3SJ-A0245P30-S

*2. The F3SJ-A□□□□-TS series with the suffix "-TS" are auto reset fixed models. Function settings using the setting console F39-MC21 or PC tool F39-GWUM for F3SJ cannot be performed.

(Models with detection capability 25 mm dia. are also available.)

Safety Light Curtain Model List

F3SJ-A14 Series (9 mm gap)

Model		Number of Beams	Protective Height (mm) *
PNP Output	NPN Output		
F3SJ-A0245P14	F3SJ-A0245N14	26	245
F3SJ-A0263P14	F3SJ-A0263N14	28	263
F3SJ-A0299P14	F3SJ-A0299N14	32	299
F3SJ-A0317P14	F3SJ-A0317N14	34	317
F3SJ-A0389P14	F3SJ-A0389N14	42	389
F3SJ-A0461P14	F3SJ-A0461N14	50	461
F3SJ-A0551P14	F3SJ-A0551N14	60	551
F3SJ-A0623P14	F3SJ-A0623N14	68	623
F3SJ-A0695P14	F3SJ-A0695N14	76	695
F3SJ-A0731P14	F3SJ-A0731N14	80	731
F3SJ-A0803P14	F3SJ-A0803N14	88	803
F3SJ-A0875P14	F3SJ-A0875N14	96	875
F3SJ-A0983P14	F3SJ-A0983N14	108	983
F3SJ-A1055P14	F3SJ-A1055N14	116	1,055
F3SJ-A1127P14	F3SJ-A1127N14	124	1,127
F3SJ-A1199P14	F3SJ-A1199N14	132	1,199
F3SJ-A1271P14	F3SJ-A1271N14	140	1,271

*Protective Height (mm) = Total sensor length

F3SJ-A20 Series (15 mm gap)

Model		Number of Beams	Protective Height (mm) *
PNP Output	NPN Output		
F3SJ-A0245P20	F3SJ-A0245N20	16	245
F3SJ-A0275P20	F3SJ-A0275N20	18	275
F3SJ-A0305P20	F3SJ-A0305N20	20	305
F3SJ-A0395P20	F3SJ-A0395N20	26	395
F3SJ-A0455P20	F3SJ-A0455N20	30	455
F3SJ-A0545P20	F3SJ-A0545N20	36	545
F3SJ-A0605P20	F3SJ-A0605N20	40	605
F3SJ-A0635P20	F3SJ-A0635N20	42	635
F3SJ-A0695P20	F3SJ-A0695N20	46	695
F3SJ-A0785P20	F3SJ-A0785N20	52	785
F3SJ-A0815P20	F3SJ-A0815N20	54	815
F3SJ-A0875P20	F3SJ-A0875N20	58	875
F3SJ-A0935P20	F3SJ-A0935N20	62	935
F3SJ-A1025P20	F3SJ-A1025N20	68	1,025
F3SJ-A1115P20	F3SJ-A1115N20	74	1,115
F3SJ-A1205P20	F3SJ-A1205N20	80	1,205
F3SJ-A1265P20	F3SJ-A1265N20	84	1,265
F3SJ-A1445P20	F3SJ-A1445N20	96	1,445
F3SJ-A1505P20	F3SJ-A1505N20	100	1,505

*Protective Height (mm) = Total sensor length

F3SJ-A30 Series (25 mm gap)

Model		Number of Beams	Protective Height (mm) *
PNP Output	NPN Output		
F3SJ-A0245P30	F3SJ-A0245N30	10	245
F3SJ-A0295P30	F3SJ-A0295N30	12	295
F3SJ-A0395P30	F3SJ-A0395N30	16	395
F3SJ-A0470P30	F3SJ-A0470N30	19	470
F3SJ-A0520P30	F3SJ-A0520N30	21	520
F3SJ-A0545P30	F3SJ-A0545N30	22	545
F3SJ-A0570P30	F3SJ-A0570N30	23	570
F3SJ-A0620P30	F3SJ-A0620N30	25	620
F3SJ-A0720P30	F3SJ-A0720N30	29	720
F3SJ-A0795P30	F3SJ-A0795N30	32	795
F3SJ-A0870P30	F3SJ-A0870N30	35	870
F3SJ-A0920P30	F3SJ-A0920N30	37	920
F3SJ-A0945P30	F3SJ-A0945N30	38	945
F3SJ-A0995P30	F3SJ-A0995N30	40	995
F3SJ-A1020P30	F3SJ-A1020N30	41	1,020
F3SJ-A1095P30	F3SJ-A1095N30	44	1,095
F3SJ-A1120P30	F3SJ-A1120N30	45	1,120
F3SJ-A1195P30	F3SJ-A1195N30	48	1,195
F3SJ-A1270P30	F3SJ-A1270N30	51	1,270
F3SJ-A1395P30	F3SJ-A1395N30	56	1,395
F3SJ-A1620P30	F3SJ-A1620N30	65	1,620
F3SJ-A1745P30	F3SJ-A1745N30	70	1,745
F3SJ-A1870P30	F3SJ-A1870N30	75	1,870
F3SJ-A1995P30	F3SJ-A1995N30	80	1,995
F3SJ-A2245P30	F3SJ-A2245N30	90	2,245
F3SJ-A2370P30	F3SJ-A2370N30	95	2,370
F3SJ-A2495P30	F3SJ-A2495N30	100	2,495

*Protective Height (mm) = Total sensor length

F3SJ-A55 Series (50 mm gap)

Model		Number of Beams	Protective Height (mm) *
PNP Output	NPN Output		
F3SJ-A0270P55	F3SJ-A0270N55	6	270
F3SJ-A0320P55	F3SJ-A0320N55	7	320
F3SJ-A0370P55	F3SJ-A0370N55	8	370
F3SJ-A0470P55	F3SJ-A0470N55	10	470
F3SJ-A0570P55	F3SJ-A0570N55	12	570
F3SJ-A0620P55	F3SJ-A0620N55	13	620
F3SJ-A0720P55	F3SJ-A0720N55	15	720
F3SJ-A0770P55	F3SJ-A0770N55	16	770
F3SJ-A0870P55	F3SJ-A0870N55	18	870
F3SJ-A0920P55	F3SJ-A0920N55	19	920
F3SJ-A0970P55	F3SJ-A0970N55	20	970
F3SJ-A1020P55	F3SJ-A1020N55	21	1,020
F3SJ-A1120P55	F3SJ-A1120N55	23	1,120
F3SJ-A1170P55	F3SJ-A1170N55	24	1,170
F3SJ-A1270P55	F3SJ-A1270N55	26	1,270
F3SJ-A1320P55	F3SJ-A1320N55	27	1,320
F3SJ-A1420P55	F3SJ-A1420N55	29	1,420
F3SJ-A1570P55	F3SJ-A1570N55	32	1,570
F3SJ-A1770P55	F3SJ-A1770N55	36	1,770
F3SJ-A1920P55	F3SJ-A1920N55	39	1,920
F3SJ-A2070P55	F3SJ-A2070N55	42	2,070
F3SJ-A2220P55	F3SJ-A2220N55	45	2,220
F3SJ-A2370P55	F3SJ-A2370N55	48	2,370
F3SJ-A2470P55	F3SJ-A2470N55	50	2,470

*Protective Height (mm) = Total sensor length

Accessories (Sold separately)

Single-Ended Cable (2 cables per set, one for emitter and one for receiver) *

For wiring with safety circuit such as single safety relay, safety relay unit, and safety controller

Appearance	Cable length	Specifications	Model
	3 m	M12 connector (8-pin)	F39-JD3A
	7 m		F39-JD7A
	10 m		F39-JD10A
	15 m		F39-JD15A
	20 m		F39-JD20A

* The cable for emitter and the cable for receiver are available separately. Add '-L' for emitter or '-D' for receiver to the end of the model number when you order.
Single-Ended Cable for Emitter: F39-JD□A-L, Single-Ended Cable for Receiver: F39-JD□A-D

Note: To extend the cable length to 20 m or more, add the F39-JD□B Double-Ended Cable.

Example: When using a cable of 30 m, connect the F39-JD10A Single-Ended Cable with the F39-JD20B Double-Ended Cable.

Double-Ended Cable (2 cables per set, one for emitter and one for receiver) *

Control unit for connection with F3SP-B1P, to extend the length under series connection (*)

Appearance	Cable length	Specifications	Model
	0.5 m	M12 connector (8-pin)	F39-JDR5B
	1 m		F39-JD1B
	3 m		F39-JD3B
	5 m		F39-JD5B
	7 m		F39-JD7B
	10 m		F39-JD10B
	15 m		F39-JD15B
	20 m		F39-JD20B

* The cable for emitter and the cable for receiver are available separately. Add '-L' for emitter or '-D' for receiver to the end of the model number when you order.
Double-Ended Cable for Emitter: F39-JD□B-L, Double-Ended Cable for Receiver: F39-JD□B-D

Note: To extend the cable length to 20 m or more, use the Double-Ended Cables in combination.

Example: When using a cable of 30 m, connect the F39-JD10B Double-Ended Cable with the F39-JD20B Double-Ended Cable.

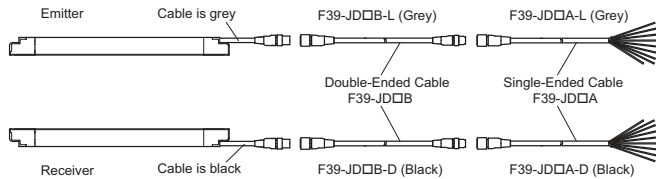



Power cable (included in the main unit. 2 cables per set, one for emitter and one for receiver)

Appearance	Cable Length	Model
	0.3 m	F39-JJR3K

Note: This product is for F3SJ-A only.

Series-connection Cable (2 cables per set, for emitter and receiver)

Type	Appearance	Cable Length	Model	Application
Series connection cable		0.3 m	F39-JJR3W *1	For series connection *2 When using the Water-resistant Case. *3
Side-by-side Series connection cable		0.06 m	F39-JJR06L *1	Dedicated cable to materialize series connection with minimum length without connector cable of the main sensor unit
		0.15 m	F39-JJR15L *1	

*1. This product is for F3SJ-A only.

*2. For series connection with minimum length, use F39-JJR06L or F39-JJR15L.

*3. When using the F39-EJ□□□□-L/D Water-resistant Case in series connection configurations, use the special series connection cables for the Water-resistant Case. Refer to page 73 for details.

Note: The Double-Ended Cable (up to 15 m: F39-JD15B) can be added to extend the cable length between the series-connected sensors.
Cable length between sensors: 15 m max. (not including series connection cable (F39-JJR3W or F39-JJR□L) and power cable)

<Connection example>

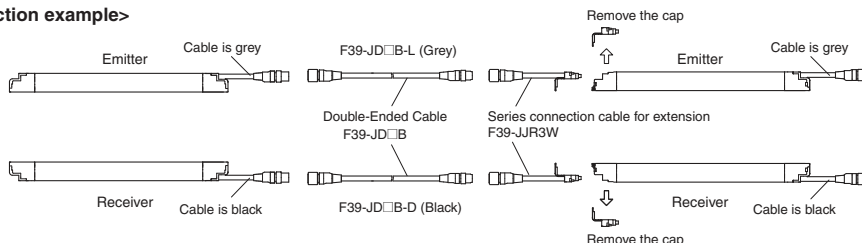

Simple wiring connector system (Order the F39-CN5 and Cables for Simple Wiring.)

Simple wiring connector

Appearance	Model	Application
	F39-CN5	To reduce wiring

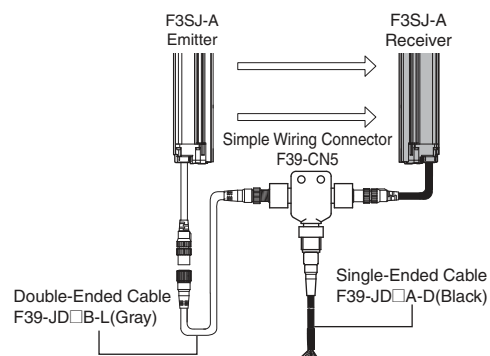

Cable for simple wiring * (2 cables per set, one double-ended cable and one single-ended cable)



Appearance	Contents		Cable length	Model
	Double-Ended Cable	F39-JD3B-L	3 m	F39-JD0303BA
	Single-Ended Cable	F39-JD3A-D	3 m	
	Double-Ended Cable	F39-JD3B-L	3 m	F39-JD0307BA
	Single-Ended Cable	F39-JD7A-D	7 m	
	Double-Ended Cable	F39-JD3B-L	3 m	F39-JD0310BA
	Single-Ended Cable	F39-JD10A-D	10 m	
	Double-Ended Cable	F39-JD5B-L	5 m	F39-JD0503BA
	Single-Ended Cable	F39-JD3A-D	3 m	
	Double-Ended Cable	F39-JD5B-L	5 m	F39-JD0507BA
	Single-Ended Cable	F39-JD7A-D	7 m	
	Double-Ended Cable	F39-JD5B-L	5 m	F39-JD0510BA
	Single-Ended Cable	F39-JD10A-D	10 m	
	Double-Ended Cable	F39-JD10B-L	10 m	F39-JD1003BA
	Single-Ended Cable	F39-JD3A-D	3 m	
	Double-Ended Cable	F39-JD10B-L	10 m	F39-JD1007BA
	Single-Ended Cable	F39-JD7A-D	7 m	
	Double-Ended Cable	F39-JD10B-L	10 m	F39-JD1010BA
	Single-Ended Cable	F39-JD10A-D	10 m	

Note: A double-ended cable and single-ended cable with other cable lengths than those listed above can also be used in combination. Please contact your OMRON sales representative for details.

*Although the double-ended cable for the emitter is used for the emitter in the above figure, it can also be used for the receiver.

F3SJ-A

Relays with Forcibly Guided Contacts

Type	Appearance	Specifications	Model	Remarks
G7SA Relays with Forcibly Guided Contacts		<ul style="list-style-type: none"> Nodes: 4 Contact type: 2A2B Rated switch load: 250 VAC 6 A, 30 VDC 6 A 	G7SA-2A2B	For details on other models or socket models, refer to the OMRON's website.
		<ul style="list-style-type: none"> Nodes: 4 Contact type: 3NO+1NC Rated switch load: 250 VAC 6 A, 30 VDC 6 A 	G7SA-3A1B	
G7S-□-E Relays with Forcibly Guided Contacts		<ul style="list-style-type: none"> Nodes: 6 Contact type: 4NO+2NC Rated switch load: 250 VAC 10 A, 30 VDC 10 A 	G7S-4A2B-E	For details on other models or socket models, refer to the OMRON's website.
		<ul style="list-style-type: none"> Nodes: 6 Contact type: 3NO+3NC Rated switch load: 250 VAC 10 A, 30 VDC 10 A 	G7S-3A3B-E	

Control Unit (Can not be used as a muting system) (Dedicated PNP output type) *

Appearance	Output	Model	Remarks
	Relay, 3NO+1NC	F3SP-B1P *	For connection with F3SJ-A, use a double-ended cable F39-JD□B.

*F3SJ for NPN output type cannot be connected.

Wire-saving Devices

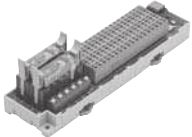
Type	Appearance	Specifications	Model	Remarks
Connector Terminal Box/ Muting Terminals		Model with PNP Muting Sensor Output	F39-TC5P01	Significantly reduces amount of wiring between Safety Light Curtains and Muting Sensors. IP67 model for mounting at Sensor installation site. For details, refer to the OMRON's website.
		Model with PNP Override Input	F39-TC5P02	
		Model with NPN Muting Sensor Output	F39-TC5N01	
		Model with NPN Override Input	F39-TC5N02	
Safety Terminal Relays		PNP output relay, SPDT-NO	F3SP-T01 *	Significantly reduces amount of wiring between Safety Light Curtains and Muting Sensors. For details, refer to the OMRON's website.

*F3SJ for NPN output type cannot be connected.

Laser Pointer

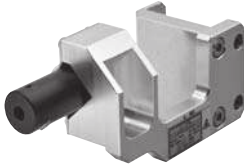
Appearance	Output	Model
	Laser Pointer for F3SJ	F39-PTJ

Dedicated External Indicator Set (can be connected to either an emitter or a receiver)

Appearance	Color	Model	Remarks
	Red	F39-A01PR-PAC	Indicator (red), mounting bracket 1 set, and dedicated connection cable (0.1 m)
	Green	F39-A01PG-PAC	Indicator (green), mounting bracket 1 set, and dedicated connection cable (0.1 m)
	Yellow	F39-A01PY-PAC	Indicator (yellow), mounting bracket 1 set, and dedicated connection cable (0.1 m)

Note: 1. For indication timing (operation mode), see "Specifications" on page 74.
 2. This product is for F3SJ-A only.

General External Indicator Cable

Appearance	Cable Length	Specifications	Model
	3 m	Cable to connect top of the main unit and an off-the-shelf external indicator (2-wire)	F39-JJ3N *

* This product is for F3SJ-A only.

Spatter Protection Cover (2 cables per set, one for emitter and one for receiver) (10% Operating Range Attenuation)

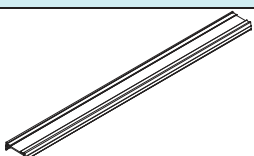
Appearance	Model
	F39-HJ□□□□ *1 *2

*1. This product is for F3SJ-A only.

*2. The same 4-digit numbers as the protective heights (□□□□ in the light curtain model names) are substituted by in the model names.

Mirrors (12% Operating Range Attenuation)

Appearance	Mirror material	Width (mm)	Thickness (mm)	Length L (mm)	Model	Remarks
	Glass mirror	145	32	445	F39-MLG0406	2 sets of cylinder mounting brackets and 4 screws are included.
				648	F39-MLG0610	
				749	F39-MLG0711	
				953	F39-MLG0914	
				1,105	F39-MLG1067	
				1,257	F39-MLG1219	
				1,499	F39-MLG1422	
				1,702	F39-MLG1626	
				1,905	F39-MLG1830	
				2,210	F39-MLG2134	

Test rod (Sold separately)

Diameter	Model
14mm dia.	F39-TRD14
20mm dia.	F39-TRD20
25mm dia.	F39-TRD25
30mm dia.	F39-TRD30

F3SJ-A

Sensor Mounting Brackets (Sold separately)

Appearance	Specifications	Model	Application	Remarks
	Standard mounting bracket (for top/bottom)	F39-LJ1	(provided with the F3SJ)	2 for an emitter, 2 for a receiver, total of 4 per set
	Flat side mounting bracket	F39-LJ2	Use these small-sized brackets when performing side mounting with standard mounting brackets, so that they do not protrude from the detection surface.	2 for an emitter, 2 for a receiver, total of 4 per set
	Free-location mounting bracket (also used as standard intermediate bracket)	F39-LJ3	Use these brackets for mounting on any place without using standard bracket.	Two brackets per set (For details about the number of required brackets, refer to page 89.)
	F3SN Intermediate Bracket Replacement Spacers	F39-LJ3-SN	When replacing the F3SN with the F3SJ, the mounting hole pitches in the Intermediate Brackets are not the same. This Spacer is placed between the mounting holes to mount the F3SJ.	1 set with 2 pieces
	Top/bottom bracket B (Mounting hole pitch 19 mm)	F39-LJ4	Mounting bracket used when replacing existing area sensors (other than F3SN or F3WN) with the F3SJ. For front mounting. Suitable for mounting hole pitch of 18 to 20 mm.	2 for an emitter, 2 for a receiver, total of 4 per set
	Bracket for replacing short-length F3SN	F39-LJ5	Mounting bracket used when an F3SN with protective height of 300 mm or less is replaced by an F3SJ.	2 for an emitter, 2 for a receiver, total of 4 per set
	Space-saving mounting bracket	F39-LJ8	Use these brackets to mount facing inward. Length is 12 mm shorter than the standard F39-LJ1 bracket.	2 for an emitter, 2 for a receiver, total of 4 per set
	Mounting bracket used when replacing an F3W-C.	F39-LJ9	Mounting bracket used when replacing existing F3W-C series area sensors with the F3SJ. For front mounting or side mounting. Mounting hole pitch 16 mm.	2 for an emitter, 2 for a receiver, total of 4 per set
	Top/bottom bracket C (mounting hole pitch 13 mm)	F39-LJ11	Mounting bracket used when replacing existing area sensors having a mounting pitch of 13 mm with the F3SJ.	2 for an emitter, 2 for a receiver, total of 4 per set

End Cap

Appearance	Model	Remarks
	F39-CN9	For both emitter and receiver. The End Cap can be purchased if lost. (Case: Black)



* This product is for F3SJ-A only.

Key Cap for Muting

Appearance	Model	Remarks
	F39-CN6	A cap to be attached to the main unit to enable muting function. Attach it to either an emitter or a receiver. (Case: orange)

* This product is for F3SJ-A only.

Setting Tools *1

Type	Appearance	Model	Remarks
"SD Manager" Setting Support Software for the F3SJ		F39-GWUM *2	Accessories: SD Manager CD-ROM (1), F39-CN1 Branch Connector (1), Connector Cap (1), 2-m Dedicated Cable (1), 0.3-m Dedicated Cable with Plug (1), Instruction Manual
Setting Console		F39-MC21 *3	Accessories: F39-CN1 Branch Connector (1), Connector Cap (1), 2-m Dedicated Cable (1), 0.3-m Dedicated Cable with Plug (1), Instruction Manual

*1. The setting tools described above can be connected only to F3SJ-A models with built-in software of Ver. 2 or later.



Note that the setting tools cannot be used with products shipped prior to December 2005.

The setting tools cannot be used for setting parameters on the F3SJ-A□-TS series, but the monitoring function can be used.

*2. The PC tool supports Windows XP/7.

*3. This product is for use only with the F3SJ-A. It cannot be connected to conventional models of the F3SJ-E/B or F3SN-A series.

Protective Bar *1 *2



Type	Appearance	Model	Remarks
Protective Bar		F39-PJ□□□□-S *3	Main unit bracket (1), rear mounting brackets (2), including intermediate brackets to match protective height (0 to 2).
Intermediate brackets for side mounting		F39-PJ-MS	For side mounting, order to suit the desired protective height. Protective height of up to 1,000 mm: 0 intermediate brackets Protective height of 1,001 to 2,000 mm: 1 intermediate bracket Protective height of 2,001 mm or more: 2 intermediate brackets

*1. This product is for F3SJ-A only.

*2. When using for both emitter and receiver, order two sets.

*3. The same four digits indicating protective height that are used in the Sensor model number (□□□□) are used in the part of the Protector model number.

Water-resistant Case (Set of 1 tube, packing, and dedicated connector cable) *1 *2 *3

Appearance	Specifications	Model	Remarks
	For emitter	F39-EJ□□□□-L *4	Includes gray cable for emitter.
	For receiver	F39-EJ□□□□-D *4	Includes black cable for receiver.
	Rear Mounting Brackets	F39-EJ-R *5	Top/bottom 1 each, total of 2
	Side Mounting Brackets	F39-EJ-S *5	Top/bottom 1 each, total of 2
---	Series connection cable (for emitter)	F39-JJR3WE-L	Purchase additionally for series connection when using the Water-resistant Case.
	Series connection cable (for receiver)	F39-JJR3WE-D	

*1. This product is for F3SJ-A only.

*2. When using for both emitter and receiver, order two sets.

*3. There are restrictions to the application conditions depending on the protective height of the Curtain. Refer to the Water-resistant Case on page 77.

*4. The same four digits indicating protective height that are used in the Sensor model number (□□□□) are used in the part of the Protector model number.

*5. Be sure to purchase brackets with the Case to match the mounting direction (rear or side).

F3SJ-A

Specifications (For details, refer to the instruction manual or User's manual.)

F3SJ-A□□□□P14/P20/P30/P55/N14/N20/N30/N55

Model	PNP Output	F3SJ-A□□□□P14	F3SJ-A□□□□P20	F3SJ-A□□□□P30	F3SJ-A□□□□P55
	NPN Output	F3SJ-A□□□□N14	F3SJ-A□□□□N20	F3SJ-A□□□□N30	F3SJ-A□□□□N55
Sensor type	Type 4 safety light curtain				
Version	Ver. 2				
Setting tool connection	Connectable				
Safety category	Safety purpose of category 4, 3, 2, 1, or B				
Detection capability	Opaque objects 14 mm in diameter	Opaque objects 20 mm in diameter	Opaque objects 30 mm in diameter	Opaque objects 55 mm in diameter	
Beam gap (P)	9 mm	15 mm	25 mm	50 mm	
Number of beams (n)	26 to 140	16 to 100	10 to 100	6 to 50	
Protective height (PH)	245 to 1,271 mm	245 to 1,505 mm	245 to 2,495 mm	270 to 2,470 mm	
Lens diameter	Diameter 5 mm				
Operating range *	0.2 to 9 m (protective height 1,640 mm max.), 0.2 to 7 m (protective height 1,655 mm min.) (Depending on the setting tool, the detection distance can be shortened to 0.5 m.)				
Response time (under stable light incident condition) (For details, see "Response Time" on page 76.)	ON to OFF	1 set, 0245 to 983: 11 ms to 17.5 ms max. 1,055 or higher: 20 ms to 25 ms max.	1 set, 0245 to 1205: 10 ms to 15 ms max. 1235 or higher: 17.5 ms to 22.5 ms max.	1 set: 10 ms to 17.5 ms max.	1 set: 10 ms to 13 ms max.
	OFF to ON	1 set, 0245 to 983: 44 ms to 70 ms max. 1,055 or higher: 80 ms to 100 ms max.	1 set, 0245 to 1205: 40 ms to 60 ms max. 1235 or higher: 70 ms to 90 ms max.	1 set: 40 ms to 70 ms max.	1 set: 40 ms to 52 ms max.
Startup waiting time	2 s max. (2.2 s max. for series connection)				
Power supply voltage (Vs)	24 VDC ±20% (ripple p-p10% max.)				
Current consumption (no load)	Emitter	To 50 beams: 76 mA max., 51 to 100 beams: 106 mA max., 101 to 150 beams: 130 mA max., 151 to 180 beams: 153 mA max., 201 to 234 beams: 165 mA max.			
	Receiver	To 50 beams: 68 mA max., 51 to 100 beams: 90 mA max., 101 to 150 beams: 111 mA max., 151 to 180 beams: 128 mA max., 201 to 234 beams: 142 mA max.			
Light source (emitted wavelength)	Infrared LED (870 nm)				
Effective aperture angle (EAA)	Based on IEC 61496-2. Within ±2.5° for both emitter and receiver when the detection distance is 3 m or over				
Safety outputs (OSSD)	PNP outputs	Two PNP transistor outputs, load current 300 mA max., residual voltage 2 V max. (except for voltage drop due to cable extension), allowable capacity load 2.2 μF, leak current 1 mA max. (This can be different from traditional logic (ON/OFF) because safety circuit is used.)			
	NPN Output	Two NPN transistor outputs, load current 300 mA max., residual voltage 2 V max. (except for voltage drop due to cable extension), allowable capacity load 2.2 μF, leak current 2mA max. (This can be different from traditional logic (ON/OFF) because safety circuit is used.)			
Auxiliary output 1 (Non-safety output)	PNP outputs	One PNP transistor output, load current 300 mA max., residual voltage 2 V max. (except for voltage drop due to cable extension), leak current 1 mA max.			
	NPN output	One NPN transistor output, load current 300 mA max., residual voltage 2 V max. (except for voltage drop due to cable extension), leak current 1 mA max.			
Auxiliary output 2 (Non-safety output. Function for Basic System.)	PNP outputs	One PNP transistor output, load current 50 mA max., residual voltage 2 V max. (except for voltage drop due to cable extension), leak current 1 mA max.			
	NPN output	One NPN transistor output, load current 50 mA max., residual voltage 2 V max. (except for voltage drop due to cable extension), leak current 1 mA max.			
External indicator output (Non-safety output)	Available indicators <ul style="list-style-type: none"> Incandescent lamp: 24 VDC, 3 to 7 W LED lamp: Load current 10 mA to 300 mA max., leak current 1 mA max. (To use an external indicator, an F39-JJ3N universal indicator cable or an F39-A01P-PAC dedicated external indicator kit is required.)				
Output operation mode	Receiver	Safety output 1, 2: ON when receiving light Auxiliary output 1: Inverse of safety output signals (Operation mode can be changed with the setting tool.) External indicator output 1: Inverse of safety output signals for a basic system (Operation mode can be changed with the setting tool.), ON when muting/override for a muting system (Operation mode can be changed with the setting tool.)			
	Emitter	Auxiliary output 2: Turns ON when the point of 30,000 operating hours is reached (Operation mode can be changed with the setting tool.) External indicator output 2: ON when lock-out for a basic system (Operation mode can be changed with the setting tool.) ON when muting/override for a muting system (Operation mode can be changed with the setting tool.)			

* Use of the Spatter Protection Cover causes a 10% maximum sensing distance attenuation.

Model	PNP output	F3SJ-A□□□□P14	F3SJ-A□□□□P20	F3SJ-A□□□□P30	F3SJ-A□□□□P55
	NPN output	F3SJ-A□□□□N14	F3SJ-A□□□□N20	F3SJ-A□□□□N30	F3SJ-A□□□□N55
Input voltage	PNP output	Test input, Interlock select input, Reset input, Muting input: ON voltage: 9 V to Vs (short circuit current: approx. 2.0 mA), OFF voltage: 0 to 1.5 V, or open External device monitoring input: ON voltage: 9 V to Vs (short circuit current: approx. 3.5 mA), OFF voltage: open Note: The Vs indicates a voltage value in your environment.			
	NPN output	Test input, Interlock select input, Reset input, Muting input: ON voltage: 0 to 1.5 V (short-circuit current: approx. 1.5 mA), OFF voltage: 9 V to Vs, or open External device monitoring input: ON voltage: 0 to 1.5 V (short-circuit current: approx. 4.0 mA), OFF voltage: open Note: The Vs indicates a voltage value in your environment.			
Indicator	Emitter	Light intensity level indicators (green LED x 2, orange LED x 3): ON based on the light intensity Error mode indicators (red LED x 3): Blink to indicate error details Power indicator (green LED x 1): ON while power is on Interlock indicator (yellow LED x 1): ON while under interlock, blinks at lockout. External device monitoring indicator (muting input 1 indicator), Blanking/test indicator (muting input 2 indicator) (green LED x 2): ON/flash according to function			
	Receiver	Light intensity level indicators (green LED x 2, orange LED x 3): ON based on the light intensity Error mode indicators (red LED x 3): Blink to indicate error details OFF output indicator (red LED x 1): ON when safety output is OFF, blinks at lockout. ON output indicator (green LED x 1): ON while safety output is ON Muting error indicator, Blanking /test indicator (green LED x 2): ON/flash according to function			
Mutual interference prevention function	Interference light prevention algorithm, sensing distance change function				
Series connection	Time division emission by series connection • Number of connections: up to 4 sets (F3SJ-A only) F3SJ-E, F3SJ-B and F3SJ-TS cannot be connected. • Total number of beams: up to 400 beams • Cable length between sensors: 15 m max. (not including series connection cable (F39-JJR3W or F39-JJR□L) and power cable) • Response time under connection: Refer to page 76				
Test function	• Self test (at power-ON and at power distribution) • External test (emission stop function by test input)				
Safety-related functions	• Start interlock, restart interlock (Must be set with a setting tool when the muting function is used.) • External device monitor • Muting (Lamp burnout detection, override function included. F39-CN6 key cap for muting is required.) • Fixed blanking (must be set by a setting tool) • Floating blanking (must be set by a setting tool)				
Connection method	Connector method (M12, 8-pin)				
Protection circuit	Output short-circuit protection, and power supply reverse polarity protection				
Ambient temperature	Operating: -10 to 55°C (no icing), Storage: -30 to 70°C				
Ambient humidity	Operating: 35% to 85% (no condensation), Storage: 35% to 95%				
Operating ambient light intensity	Incandescent lamp: receiving-surface light intensity of 3,000 lx max., Sunlight: receiving-surface light intensity of 10,000 lx max.				
Insulation resistance	20 MΩ min. (at 500 VDC)				
Withstand voltage	1,000 VAC 50/60 Hz, 1 min				
Degree of protection	IP65 (IEC 60529)				
Vibration resistance	Malfunction: 10 to 55 Hz, Multiple amplitude of 0.7 mm, 20 sweeps in X, Y, and Z directions				
Shock resistance	Malfunction: 100 m/s ² , 1,000 times each in X, Y, and Z directions				
Material	Casing (including metal parts on both ends): Aluminum, zinc die-cast Cap: ABS resin, Optical cover: PMMA resin (acrylic), Cable: Oil resistant PVC				
Net Weight *1	Calculate using the following expressions: (1) For F3SJ-A□□□□□14, weight (g) = (protective height) x 1.67 + 215 (2) For F3SJ-A□□□□□20, weight (g) = (protective height) x 1.5 + 217 (3) For F3SJ-A□□□□□30, weight (g) = (protective height) x 1.41 + 220 (4) For F3SJ-A□□□□□55, weight (g) = (protective height) x 1.3 + 220				
Gross Weight *1	Calculate using the following expressions: (1) For F3SJ-A□□□□□14, weight (g) = (protective height) x 1.7 + α (2) For F3SJ-A□□□□□20/F3SJ-A□□□□□30, weight (g) = (protective height) x 1.5 + α (3) For F3SJ-A□□□□□55, weight (g) = (protective height) x 1.4 + α The values for α are as follows: Protected height 245 to 596 mm: = 1,100 protected height 1,660 to 2,180 mm: = 2,400 Protected height 600 to 1,130 mm: = 1,500 protected height 2,195 to 2,500 mm: = 2,600 Protected height 1,136 to 1,658 mm: = 2,000				

*1. The net weight is the weight of an emitter and a receiver.

*2. The gross weight is the weight of an emitter, a receiver, included accessories and a package.

Model	PNP output	F3SJ-A□□□□P14	F3SJ-A□□□□P20	F3SJ-A□□□□P30	F3SJ-A□□□□P55
	NPN output	F3SJ-A□□□□N14	F3SJ-A□□□□N20	F3SJ-A□□□□N30	F3SJ-A□□□□N55
Accessories	Instruction manual, standard mounting bracket (F39-LJ1 bracket for top/bottom mounting), mounting brackets (intermediate) (*), error mode label, Quick Installation Manual (QIM) *. Number of intermediate brackets depends on protective height of F3SJ. • For protective height from 600 to 1,130 mm : 1 set for each of the emitter and receiver is included • For protective height from 1,136 to 1,658 mm : 2 sets for each of the emitter and receiver are included • For protective height from 1,660 to 2,180 mm : 3 sets for each of the emitter and receiver are included • For protective height from 2,195 to 2,500 mm : 4 sets for each of the emitter and receiver are included				
Applicable standards	IEC 61496-1, EN 61496-1, UL 61496-1, Type 4 ESPE (Electro-Sensitive Protective Equipment) IEC 61496-2, EN 61496-2, UL 61496-2, Type 4 AOPD (Active Opto-electronic Protective Devices) IEC 61508-1 to -3, EN 61508-1 to -3 SIL3 ISO 13849-1: 2006, EN ISO 13849-1: 2008 (PLe/Safety Category 4) UL 508, UL 1998, CAN/CSA C22.2 No.14, CAN/CSA C22.2 No.0.8				

Response Time

Model	Protected Height (mm)	Number of Beams	Response time ms (ON to OFF)	Response time ms (OFF to ON)
F3SJ-A□14 Series	245 to 263	26 to 28	11	44
	281 to 389	30 to 42	12	48
	407 to 497	44 to 54	13	52
	515 to 605	56 to 66	14	56
	623 to 731	68 to 80	15	60
	767 to 983	84 to 108	17.5	70
	1,055 to 1,271	116 to 140	20	80
F3SJ-A□20 Series	245	16	10	40
	275 to 425	18 to 28	11	44
	455 to 635	30 to 42	12	48
	665 to 815	44 to 54	13	52
	845 to 995	56 to 66	14	56
	1,025 to 1,205	68 to 80	15	60
	1,235 to 1,505	82 to 100	17.5	70
F3SJ-A□30 Series	245 to 395	10 to 16	10	40
	420 to 720	17 to 29	11	44
	745 to 1,045	30 to 42	12	48
	1,070 to 1,295	43 to 52	13	52
	1,395 to 1,620	56 to 65	14	56
	1,745 to 1,995	70 to 80	15	60
	2,120 to 2,495	85 to 100	17.5	70
F3SJ-A□55 Series	270 to 770	6 to 16	10	40
	820 to 1,420	17 to 29	11	44
	1,470 to 2,070	30 to 42	12	48
	2,120 to 2,470	43 to 50	13	52

Note: Use the following expressions for series connection.

For 2-set series connection:

Response time (ON to OFF): Response time of the 1st unit + Response time of the 2nd unit - 1 (ms), Response time (OFF to ON): Response time calculated by the above x 4 (ms)

For 3-set series connection:

Response time (ON to OFF):

Response time of the 1st unit + Response time of the 2nd unit + Response time of 3rd unit - 5 (ms), Response time (OFF to ON): Response time calculated by the above x 5 (ms)
 (For models with the "-TS" suffix, multiply the response time obtained by the above x 5 (ms), or use 200 ms, whichever is less.)

For 4-set series connection:

Response time (ON to OFF): Response time of the 1st unit + Response time of the 2nd unit + Response time of the 3rd unit + Response time of the 4th unit - 8 (ms)

Response time (OFF to ON): Response time calculated by the above x 5 (ms)

Cable Extension Length

Total cable extension length must be no greater than the lengths described below.

When the F3SJ and an external power supply are directly connected, or when the F3SJ is connected to a G9SA-300-SC.

Condition	1 set	2 sets	3 sets	4 sets
Using incandescent lamp for auxiliary output and external indicator output	45 m	40 m	30 m	20 m
Not using incandescent lamp *	100 m	60 m	45 m	30 m

When connected to the F3SP-B1P

Condition	1 set	2 sets	3 sets	4 sets
Using incandescent lamp for external indicator output 2	40 m	30 m	25 m	20 m
Using incandescent lamp for external indicator output 1	60 m	45 m	30 m	20 m
Using incandescent lamp for auxiliary output 1				
Not using incandescent lamp *	100 m	60 m	45 m	30 m

Note: Keep the cable length within the rated length. Failure to do so is dangerous as it may prevent safety functions from operating normally.

* The F39-A01P□-PAC Dedicated External Indicator Set uses LEDs. Refer to the cable extension lengths for "Not using incandescent lamp".

Accessories

Control Unit

Item	Model	F3SP-B1P
Applicable sensor		F3SJ-B/A (Only for PNP output type) *
Power supply voltage		24 VDC±10%
Power consumption		DC1.7 W max. (not including sensor's current consumption)
Operation time		100 ms max. (not including sensor's response time)
Response time		10 ms max. (not including sensor's response time)
Relay output	Number of contacts	3NO+1NC
	Rated load	25 VAC 5 A (cos φ = 1), 30 VDC 5 A L/R = 0 ms
	Rated current	5 A
Connection type	Between sensors	M12 connector (8-pin)
	Others	Terminal block
Weight (packed state)		Approx. 280 g
Accessories		Instruction manual

*NPN output type cannot be connected. Also, the system cannot be used as a muting system.

Laser Pointer

Item	Model	F39-PTJ
Applicable sensor		F3SJ Series
Power supply voltage		4.65 or 4.5 VDC
Battery		Three button batteries (SR44 or LR44)
Battery life *		SR44: 10 hours of continuous operation, LR44: 6 hours of continuous operation
Light source		Red semiconductor laser (wavelength: 650 nm, 1 mW max. JIS class 2, EN/IEC class 2, FDA class II)
Spot diameter (typical value)		6.5 mm at 10 m
Ambient temperature		Operating: 0 to 40°C Storage: -15 to 60°C (with no icing or condensation)
Ambient humidity		Operating and storage: 35% to 85% (with no condensation)
Material		Laser module case: aluminum Mounting bracket: aluminum and stainless
Weight		Approx. 220 g (packed)
Accessories		Laser safety standard labels (EN: 1, FDA: 3) Button batteries (SR44: 3), instruction manual

* Battery life varies depending on a battery used.

Dedicated External Indicator Set

Item	Model	F39-A01PR-PAC	F39-A01PG-PAC	F39-A01PY-PAC
Applicable sensor		F3SJ-A (Common for PNP/NPN output type. Can be attached to emitters and/or receivers)		
Light source		Red LED	Green LED	Yellow LED
Power supply voltage		24 VDC±10% (supplied by sensor)		
Consumption current		50 mA max. (supplied by sensor)		
Connection type		Dedicated accessory connector cable (Sensor side: Dedicated 10-pin connector, Indicator side: M12 8-pin connector)		
Set details		Indicator (red), Dedicated connector cable (0.1 m), Dedicated mounting bracket (1 for each)	Indicator (green), Dedicated connector cable (0.1 m), Dedicated mounting bracket (1 for each)	Indicator (yellow), Dedicated connector cable (0.1 m), Dedicated mounting bracket (1 for each)

Water-resistant Case

Item	Model	F39-EJ□□□□-L, F39-EJ□□□□-D
Applicable sensor		F3SJ-A Series Curtains with a protective height of 600 mm or shorter.
Ambient temperature		-10 to 55°C (operation and storage)
Mounting direction		No restrictions
Operating range		0.2 to 7 m (for a protective height of 1,631 mm max.), 0.2 to 5 m (for a protective height of 1,655 mm min.)
Degree of protection		IP67 (IEC 60529) (When assembled according to the application precautions)
Material		Case: Acrylic resin, Rubber: Nitrile rubber, M5 bolt: SUSXM7, M4 bolt: SUS316L, Cable: Oil-resistant PVC, Plate: SUS304, Mounting Bracket (optional): SUS304
Weight (packed state)		Calculation formula: Weight (g) = 1.5 x □□□□ + 300 (□□□□ stands for the four digits of the model number (protective height)) (The optional Mounting Brackets come in a set of two, and weigh 120 g. This weight is not included in the above formula.)

Note: 1. Vibration

When using Curtains with a protective height of 605 mm or more, the vibration performance of the applicable sensor is reduced. Do not use these Curtains in locations that are subject to vibration.

2. Operating range

When using these cases, the operating range of the applicable sensor is reduced. Check the specifications prior to use.

3. Mounting direction

When using Curtains with a protective height of 605 mm or more, some slackness occurs due to the weight of the Curtain. For this reason, mount these Curtains only in the vertical direction.

Mounting direction (the cable end and terminating end can be positioned in either direction)

Horizontal direction

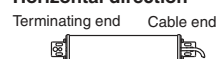

Vertical direction

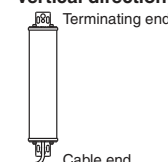

Basic Wiring Diagram

[PNP Output]

Wiring when using manual reset mode, external device monitoring

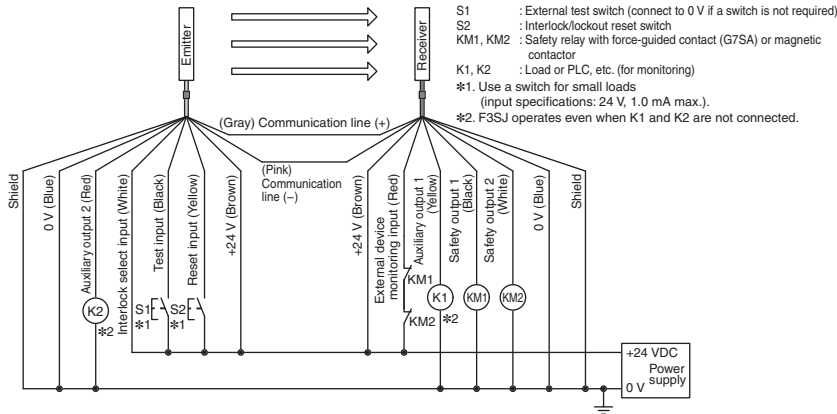

Wiring for auto reset mode

- The auto reset mode will be enabled when the emitter is wired as shown below.

- S1 : External test switch (connect to 0 V if a switch is not required)
 S3 : Lockout reset switch (connect to 24 V if a switch is not required)
 K2 : Load or PLC, etc. (for monitoring)
 *1. Use a switch for small loads (input specifications: 24 V, 1.0 mA max.).
 *2. F3SJ operates even when K2 is not connected.

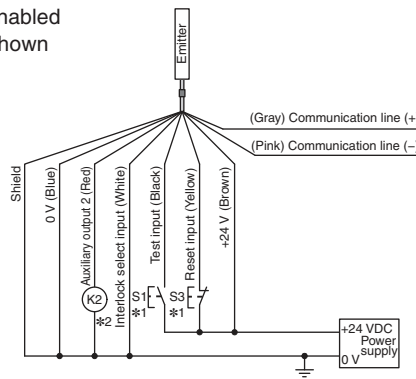

[NPN Output]

Wiring when using manual reset mode, external device monitoring

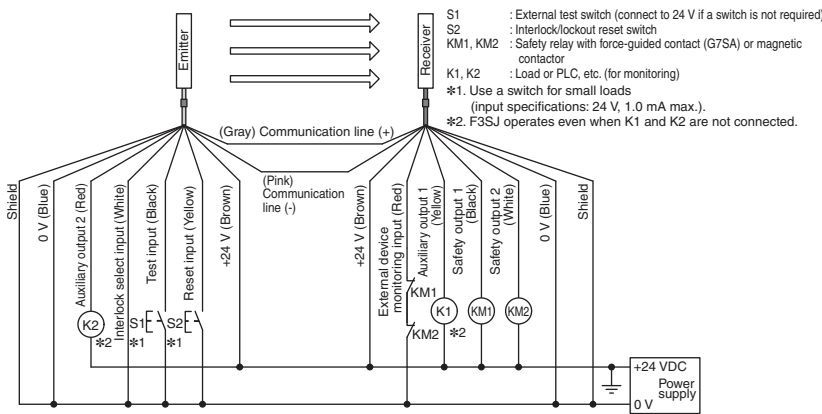

Wiring for auto reset mode

- The auto reset mode will be enabled when the emitter is wired as shown below.

- S1 : External test switch (connect to 24 V if a switch is not required)
 S3 : Lockout reset switch (connect to 0 V if a switch is not required)
 K2 : Load or PLC, etc. (for monitoring)
 *1. Use a switch for small loads (input specifications: 24 V, 1.0 mA max.).
 *2. F3SJ operates even when K2 is not connected.

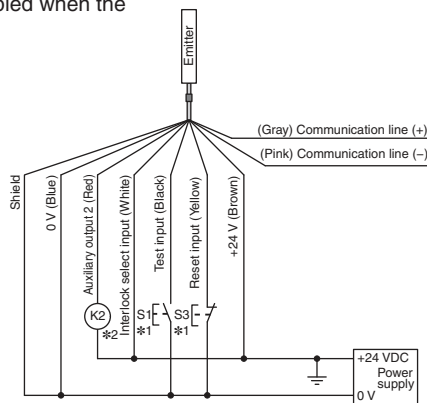

Wiring when the external device monitoring function will not be used

- Use a setting tool to set the external device monitoring function to "Disabled."
- When using an auxiliary output 1 that has not been changed (output operation mode is "control output data," and inverse of safety output signals is "Enabled), the external device monitoring function will be disabled when auxiliary output 1 and the external device monitoring input are connected as shown below.

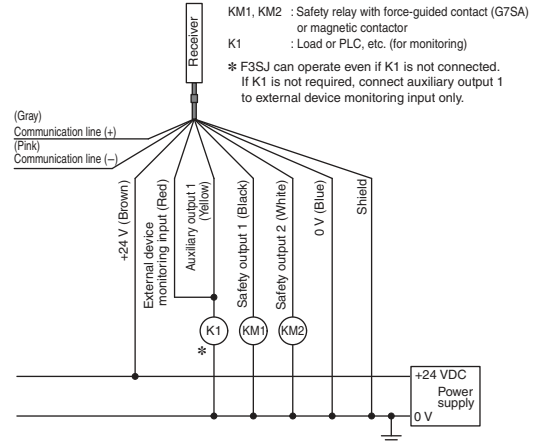

Wiring when the external device monitoring function will not be used

- Use a setting tool to set the external device monitoring function to "Disabled."
- When using an auxiliary output 1 that has not been changed (output operation mode is "safety output data," and inverse of control output signals is "Enabled), the external device monitoring function will be disabled when auxiliary output 1 and the external device monitoring input are connected as shown below.

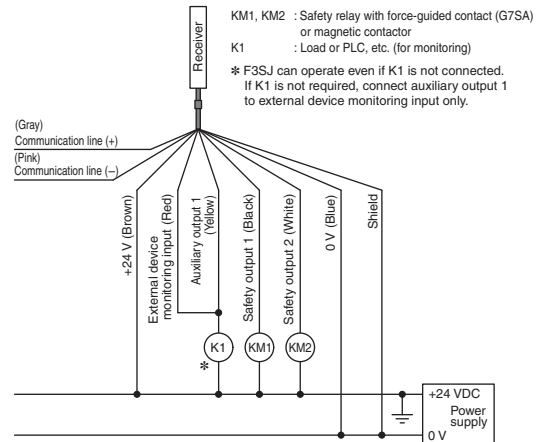

Basic Wiring Diagram for Muting System

[PNP Output]

Wiring when using muting and external device monitoring functions

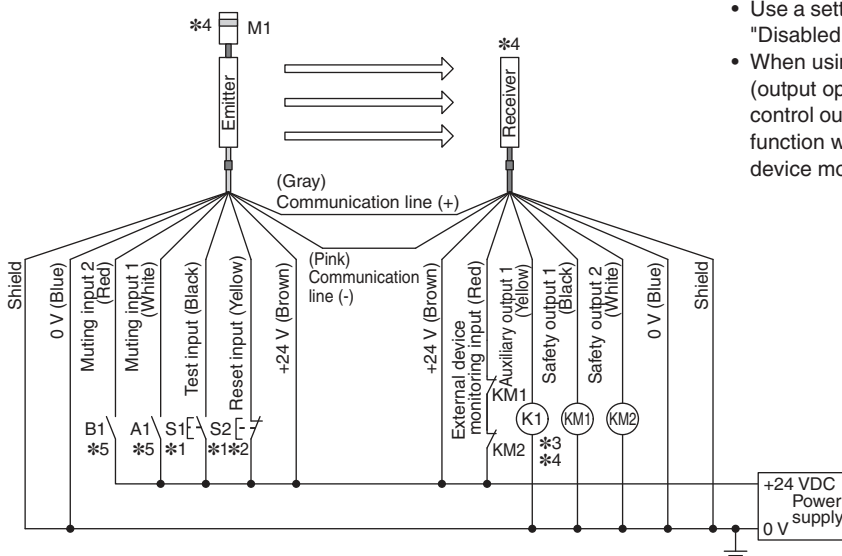

- S1 : External test switch (connect to 0 V if a switch is not required)
- S2 : Lockout reset switch (connect to 24 V if a switch is not required)
- A1 : Contact by muting sensor A1
- B1 : Contact by muting sensor B1
- KM1, KM2 : Safety relay with force-guided contact (G7SA) or magnetic contactor
- K1 : Load or PLC, etc. (for monitoring)
- M1 : Muting lamp

- *1. Use a switch for small loads (input specifications: 24 V, 1.0 mA max.).
- *2. When using the interlock function, this also functions as an interlock reset switch. (Must be set with a setting tool.)
- *3. F3SJ operates even when K1 is not connected.
- *4. Connect the muting lamp to either the external indicator output or auxiliary output 1 for the emitter or the receiver. When connecting the muting lamp to auxiliary output 1, the parameter must be changed with a setting tool.
- *5. Two-wire type muting sensor cannot be used.

When external device monitoring function is not required

- Use a setting tool to set the external device monitoring function to "Disabled."
- When using an auxiliary output 1 that has not been changed (output operation mode is "safety output data," and inverse of control output signals is "Enabled"), the external device monitoring function will be disabled when auxiliary output 1 and the external device monitoring input are connected.

[NPN Output]

Wiring when using muting and external device monitoring functions

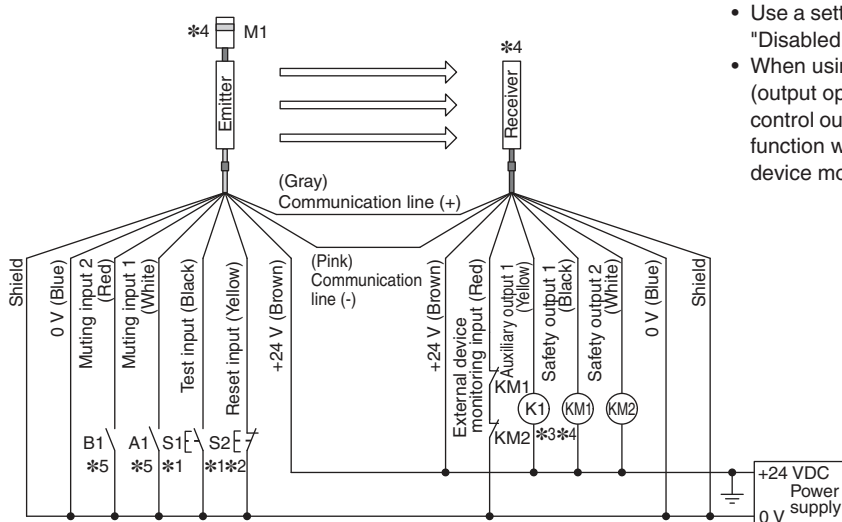

- S1 : External test switch (connect to 24 V if a switch is not required)
- S2 : Lockout reset switch (connect to 0 V if a switch is not required)
- A1 : Contact by muting sensor A1
- B1 : Contact by muting sensor B1
- KM1, KM2 : Safety relay with force-guided contact (G7SA) or magnetic contactor
- K1 : Load or PLC, etc. (for monitoring)
- M1 : Muting lamp

- *1. Use a switch for small loads (input specifications: 24 V, 1.0 mA max.).
- *2. When using the interlock function, this also functions as an interlock reset switch. (Must be set with a setting tool.)
- *3. F3SJ operates even when K1 is not connected.
- *4. Connect the muting lamp to either the external indicator output or auxiliary output 1 for the emitter or the receiver. When connecting the muting lamp to auxiliary output 1, the parameter must be changed with a setting tool.
- *5. Two-wire type muting sensor cannot be used.

When external device monitoring function is not required

- Use a setting tool to set the external device monitoring function to "Disabled."
- When using an auxiliary output 1 that has not been changed (output operation mode is "safety output data," and inverse of control output signals is "Enabled"), the external device monitoring function will be disabled when auxiliary output 1 and the external device monitoring input are connected.

Wiring Diagram When Using Simple Wiring System

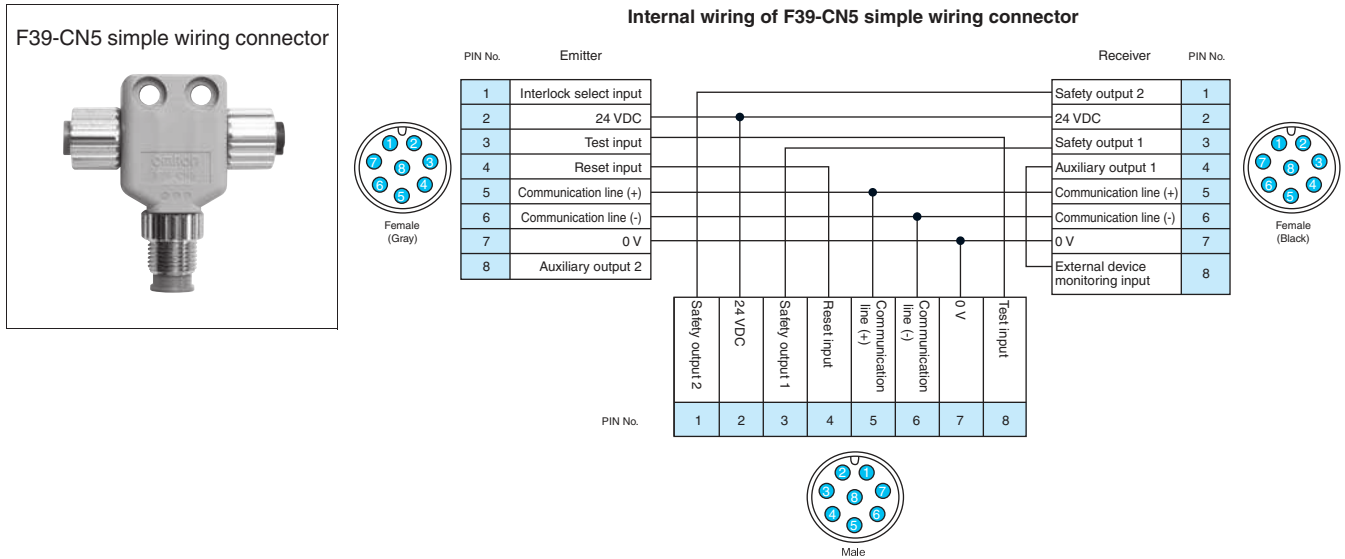

[PNP Output]

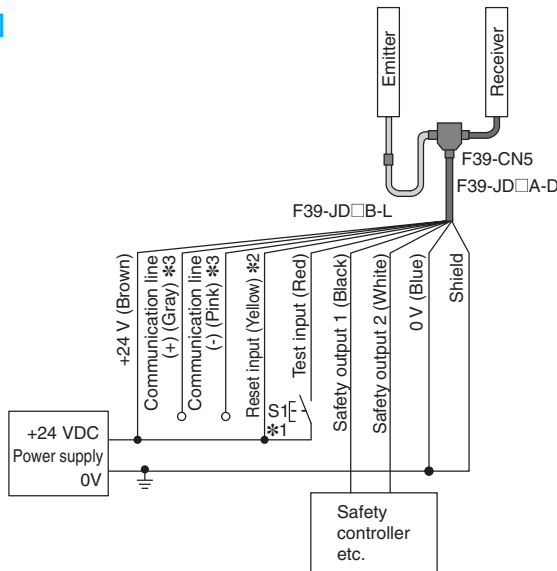

- S1 : External test switch (connect 0 V if a switch is not required)
- *1. Use a switch for small loads (input specifications: 24 V, 1.0 mA max.).
 - *2. When the lockout reset function is used, connect to 24 V via a lockout reset switch (N.C. contact).
 - *3. Make sure the Communication lines are insulated. If the lines are shorted, the F3SJ-A enters the lockout state.

Controllers connectable with PNP output F3SJ series

Safety controller	Model
Safety Network Controller	NE1A series
Safety Controller	G9SP series
Flexible Safety Unit	G9SX series
Safety Relay Unit	G9SA series

[NPN Output]

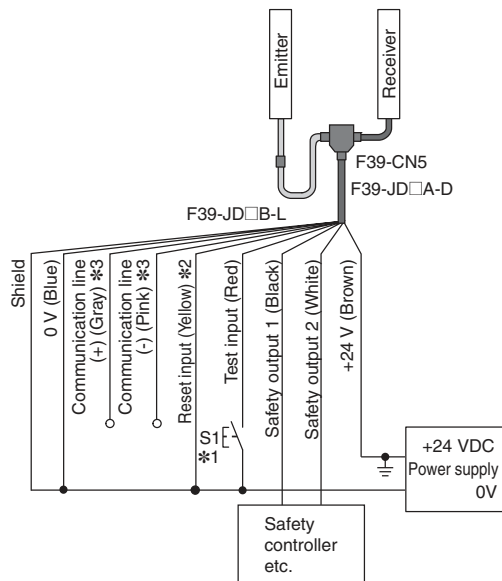

- S1 : External test switch (connect 24 V if a switch is not required)
- *1. Use a switch for small loads (input specifications: 24 V, 1.0 mA max.).
 - *2. When the lockout reset function is used, connect to 0 V via a lockout reset switch (N.C. contact).
 - *3. Make sure the Communication lines are insulated. If the lines are shorted, the F3SJ-A enters the lockout state.

Controller connectable with NPN output F3SJ series

Safety controller	Model
Safety Relay Unit	G9SA-301-P

Note: When using the Simple Wiring Connector (F39-CN5), the following functions are not available.

- Manual Reset
- External Device Monitoring
- Auxiliary Outputs 1, 2
- Muting/Override

When using the setting tools, make sure to keep the settings in the factory default.

Input/Output Circuit Diagram

Entire Circuit Diagram

[PNP Output]

The numbers in circles indicate the connectors' pin numbers.
 The black circles indicate connectors for series connection.
 The words in brackets ([]) indicate the signal name for muting system.

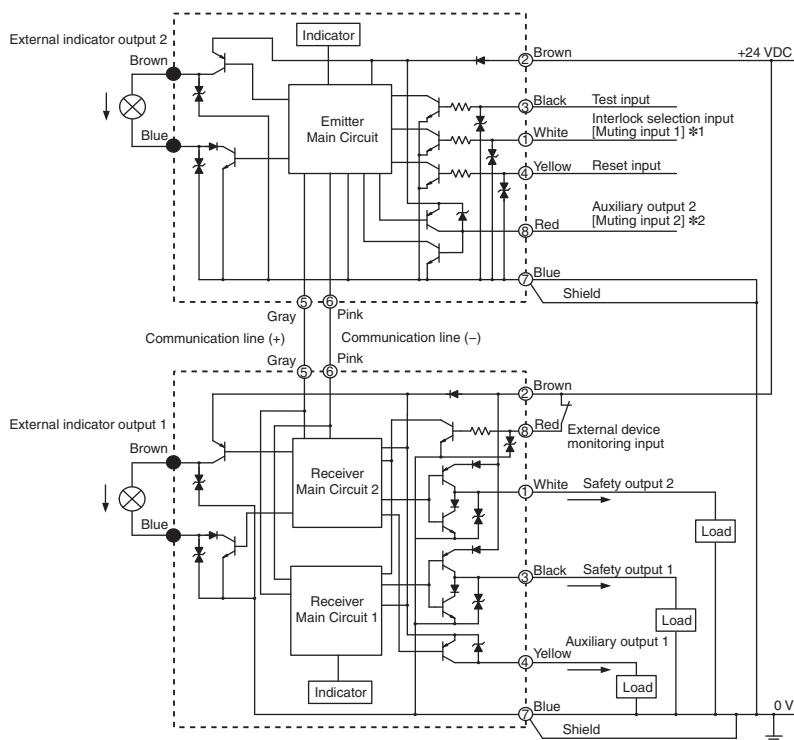

*1. Open or muting input 1 for models with the "-TS" suffix.
 *2. Open or muting input 2 for models with the "-TS" suffix.

[NPN Output]

The numbers in circles indicate the connectors' pin numbers.
 The black circles indicate connectors for series connection.
 The words in brackets ([]) indicate the signal name for muting system.

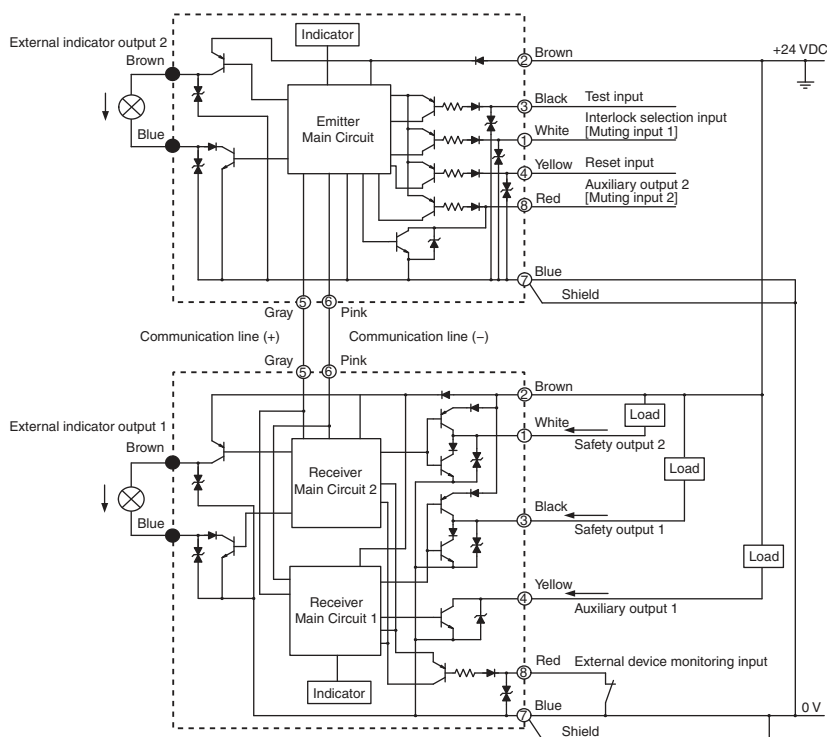

F3SJ-A

Connection Circuit Examples

Wiring for single F3SJ-A application [PNP Output]

Highest achievable PL/ safety category	Model	Stop category	Reset
PLe/4 equivalent	Safety Light Curtain F3SJ-A□□□□P□□ Safety Relay G7SA	0	Manual

Note: The above PL is only the evaluation result of the example. The PL must be evaluated in an actual application by the customer after confirming the usage conditions.

● Application Overview

- The power supply to the motor M is turned OFF when the beam is blocked.
- The power supply to the motor M is kept OFF until the beams are unblocked and the reset switch S2 is pressed.

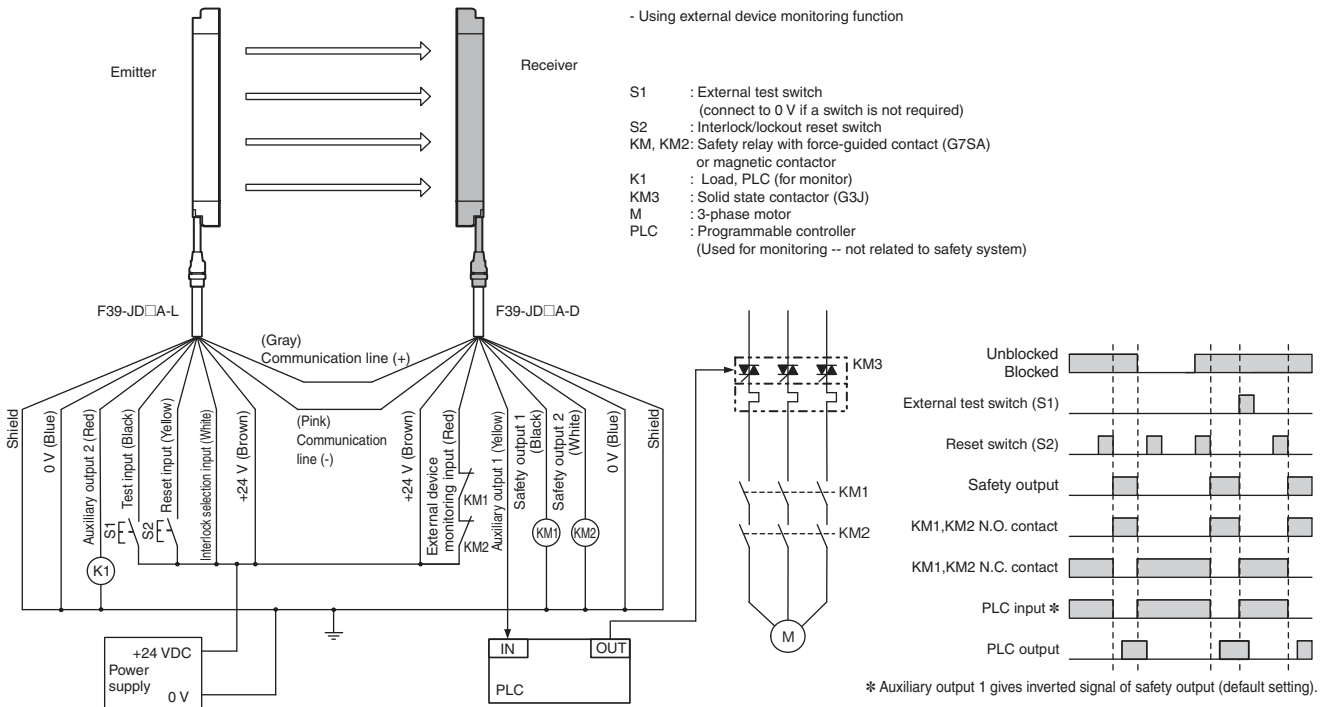

Wiring for connection with a controller F3SP-B1P [PNP Output]

Highest achievable PL/ safety category	Model	Stop category	Reset
PLe/4 equivalent	Safety Light Curtain F3SJ-A□□□□P□□ Control Unit F3SP-B1P Safety Relay G7SA	0	Manual

Note: The above PL is only the evaluation result of the example. The PL must be evaluated in an actual application by the customer after confirming the usage conditions.

● Application Overview

- The power supply to the motor M is turned OFF when the beam is blocked.
- The power supply to the motor M is kept OFF until the beams are unblocked and the reset switch S2 is pressed.

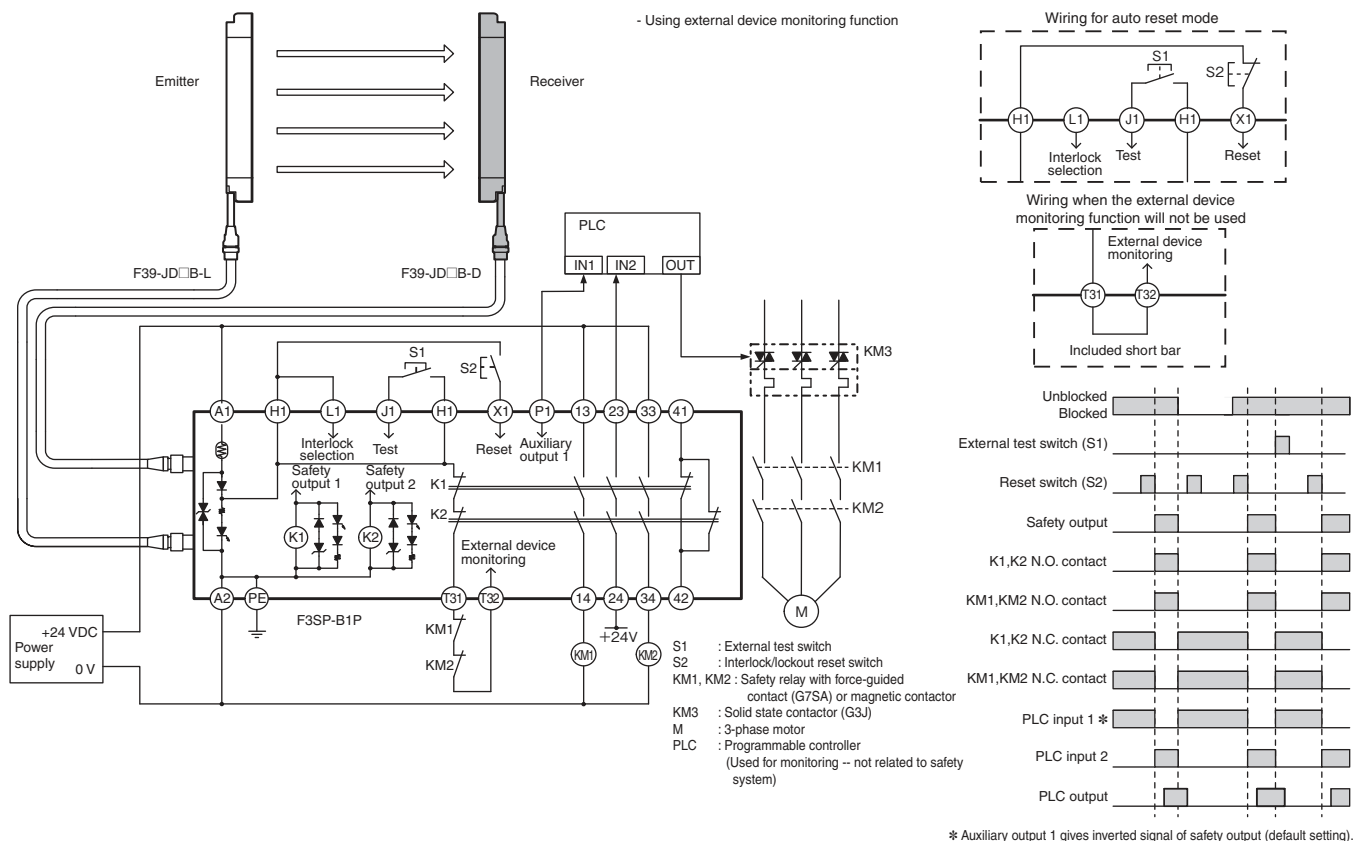

Note: It cannot be used as a muting system when F3SP-B1P is used.

Wiring for connection with a controller G9SX-AD322-T15 [PNP Output]

Highest achievable PL/ safety category	Model	Stop category	Reset
PLe/4 equivalent	Safety Light Curtain F3SJ-A□□□□P□□ Flexible Safety Unit G9SX-AD322-T15 Safety Relay G7SA	M1: 0 M2: 1	Auto

Note: The above PL is only the evaluation result of the example. The PL must be evaluated in an actual application by the customer after confirming the usage conditions.

● Application Overview

- The power supply to the motor M1 is turned OFF immediately when the beam is blocked, and stop command is sent to the motor controller for the motor M2.
- The power supply to the motor M2 is turned OFF after OFF-delay time.
- The power supply to the motor M1 and M2 is kept OFF until the beams are unblocked.

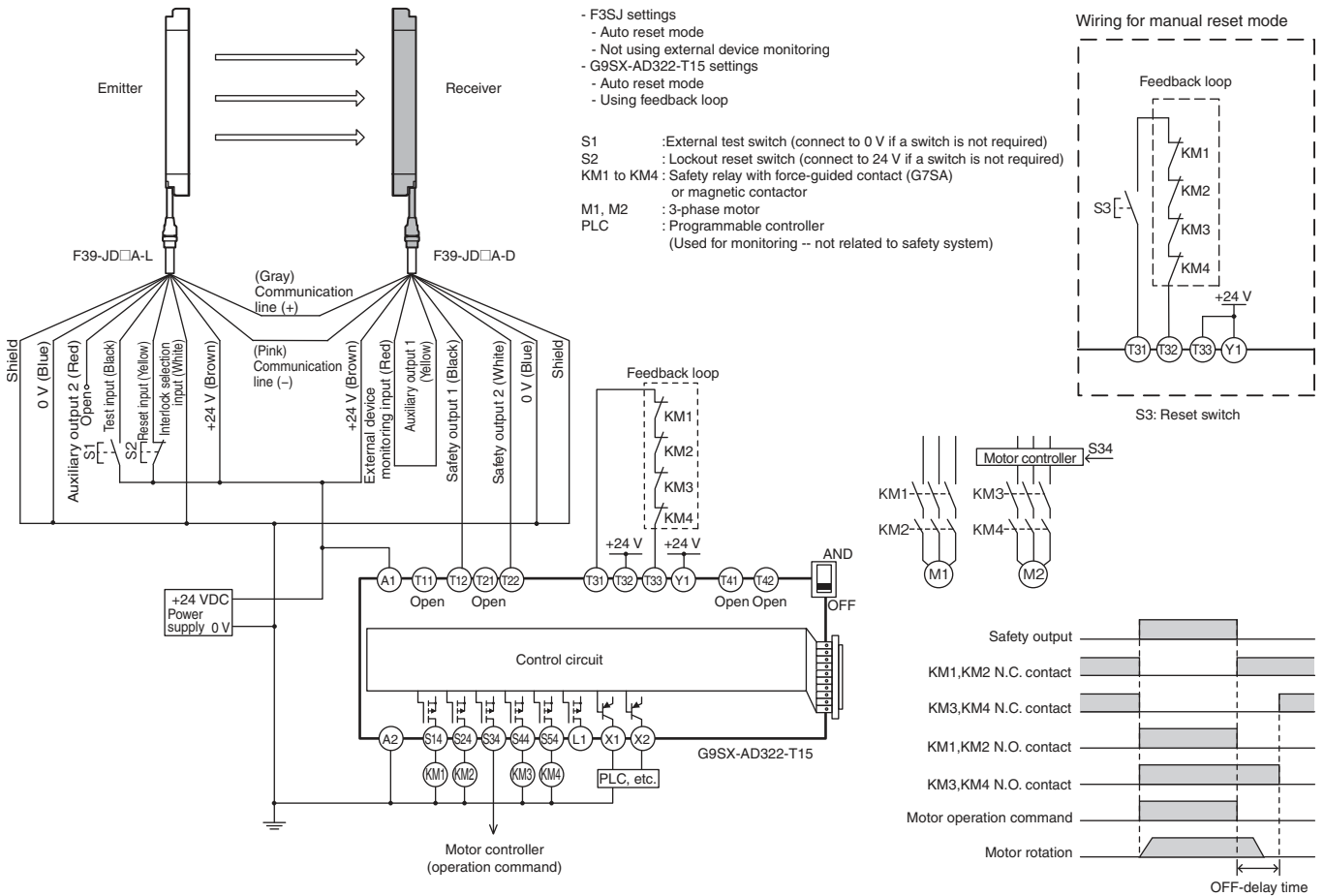

Wiring for single F3SJ-A application [NPN Output]

Highest achievable PL/ safety category	Model	Stop category	Reset
PLe/4 equivalent	Safety Light Curtain F3SJ-A□□□□N□□ Safety Relay G7SA	0	Manual

Note: The above PL is only the evaluation result of the example. The PL must be evaluated in an actual application by the customer after confirming the usage conditions.

● Application Overview

- The power supply to the motor M is turned OFF when the beam is blocked.
- The power supply to the motor M is kept OFF until the beams are unblocked and the reset switch S2 is pressed.

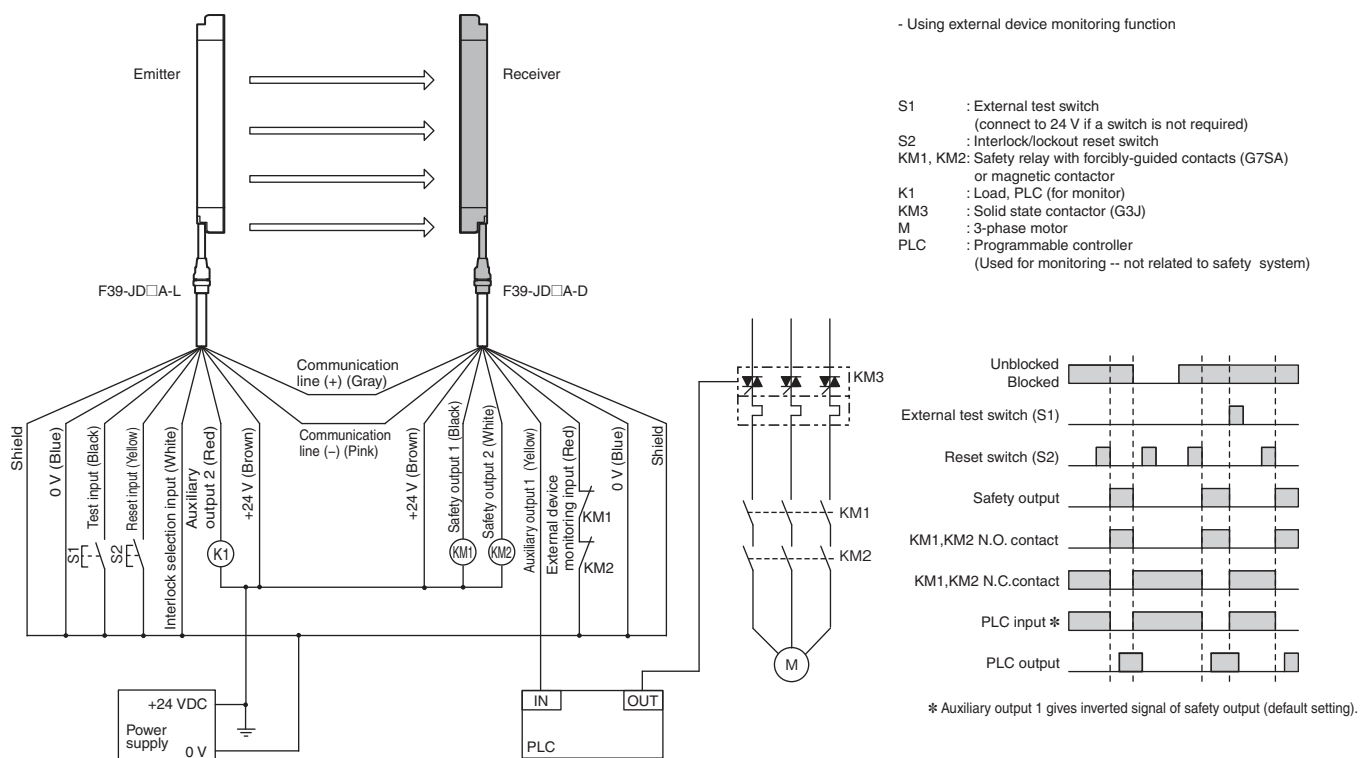

Wiring for connection with a controller G9SA-301-P [NPN Output]

Highest achievable PL/ safety category	Model	Stop category	Reset
PLe/4 equivalent	Safety Light Curtain F3SJ-A□□□□□□□□ Safety Relay Unit G9SA-301-P 24V DC Safety Relay G7SA Emergency Stop Switch A165E/A22E	0	Manual

Note: The above PL is only the evaluation result of the example. The PL must be evaluated in an actual application by the customer after confirming the usage conditions.

● Application Overview

- The power supply to the motor M is turned OFF when the beam is blocked.
- The power supply to the motor M is turned OFF when the emergency stop switch is pressed.
- The power supply to the motor M is kept OFF until the beams are unblocked and the reset switch S2 is pressed while the emergency stop switch is released.

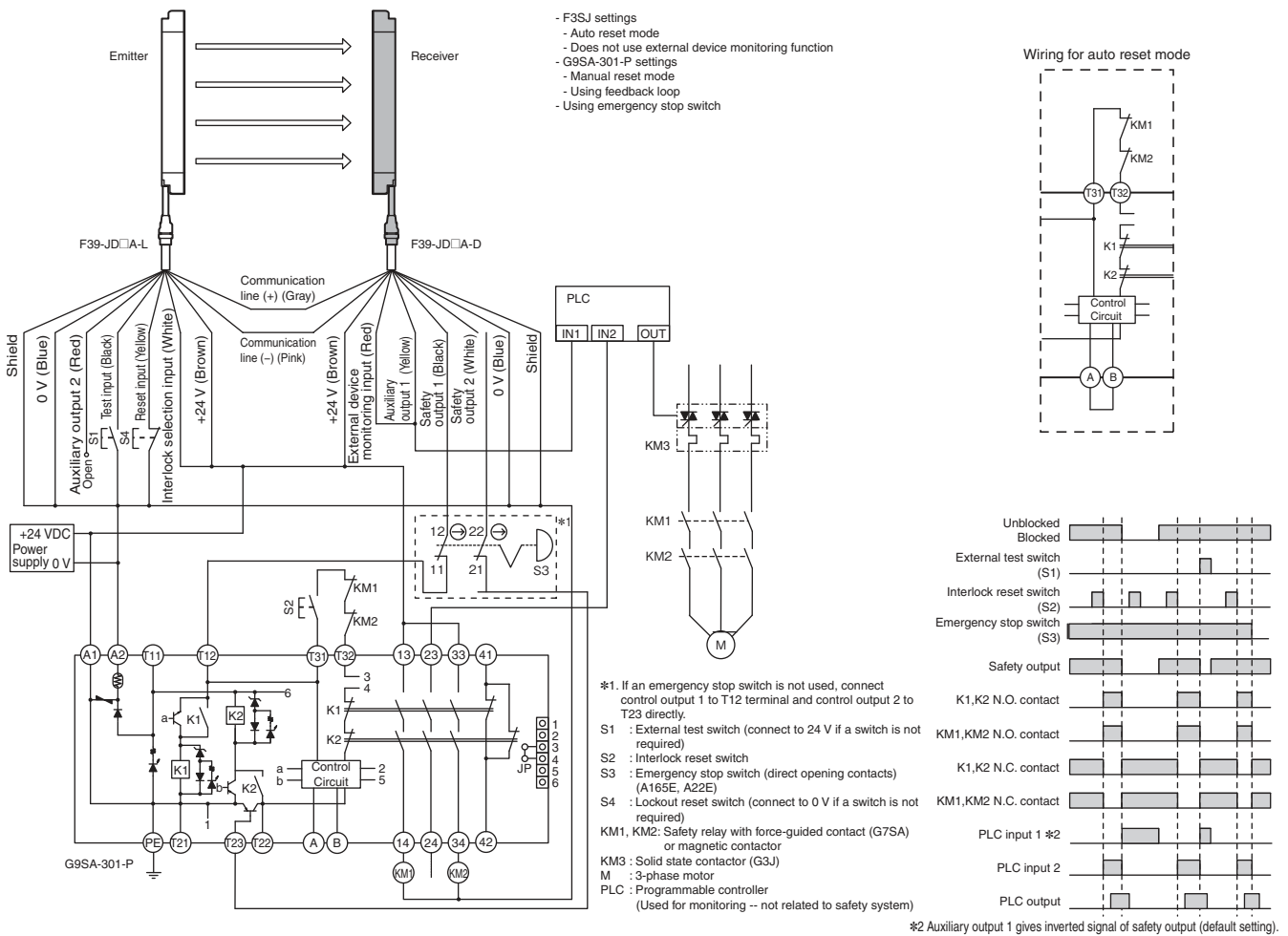

Dimensions

Main Units

When Using Standard Mounting Brackets

Backside mounting

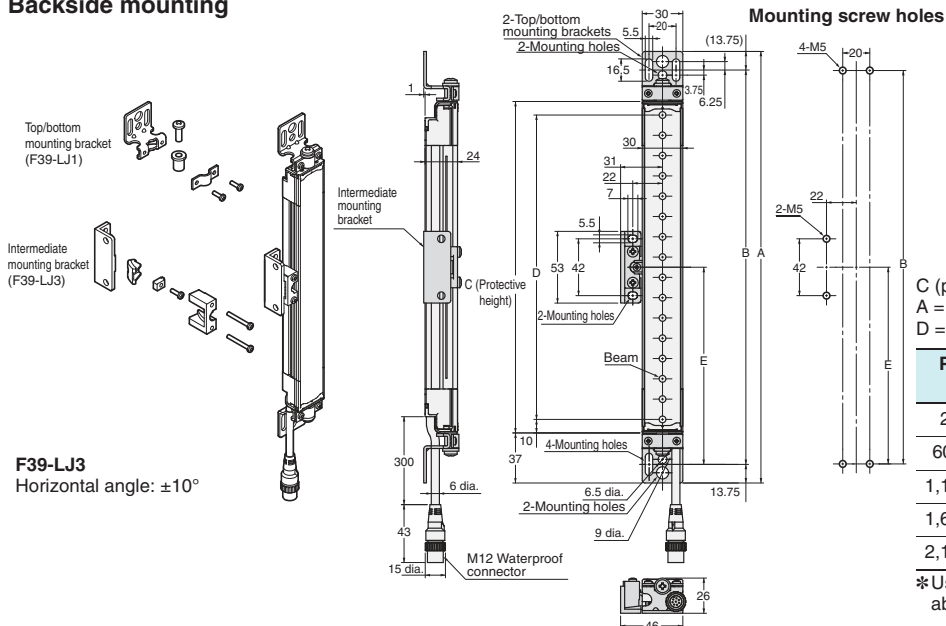

F39-LJ3
Horizontal angle: ±10°

C (protective height): 4-digit number in the table
A = C + 74, B = C + 46.5
D = C - 20, E = See table below.

Protective height	Number of intermediate brackets	E *
245 to 596	0	---
600 to 1,130	1	E = B/2
1,136 to 1,658	2	E = B/3
1,660 to 2,180	3	E = B/4
2,195 to 2,500	4	E = B/5

*Use E = 530 or less when none of the E values shown above are used.

Side mounting

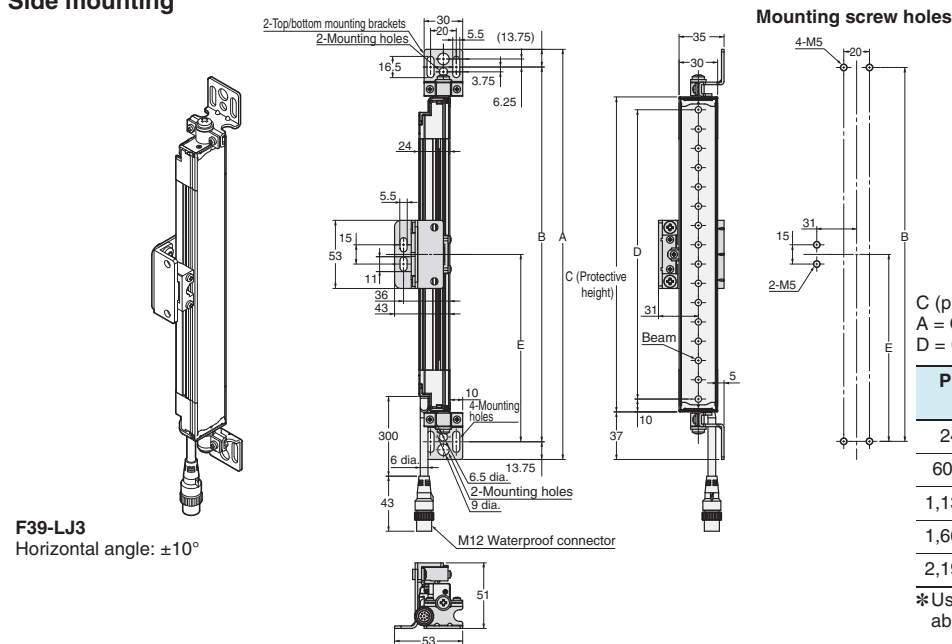

F39-LJ3
Horizontal angle: ±10°

C (protective height): 4-digit number in the table
A = C + 74, B = C + 46.5
D = C - 20, E = See table below.

Protective height	Number of intermediate brackets	E *
245 to 596	0	---
600 to 1,130	1	E = B/2
1,136 to 1,658	2	E = B/3
1,660 to 2,180	3	E = B/4
2,195 to 2,500	4	E = B/5

*Use E = 530 or less when none of the E values shown above are used.

F39-LJ1 Detailed Dimensions of Bracket

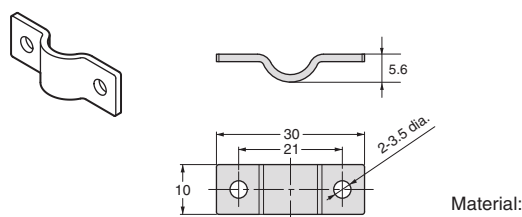
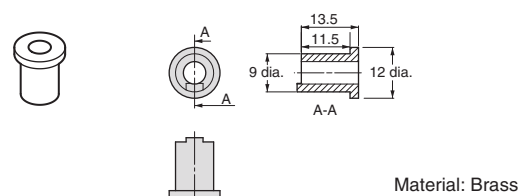
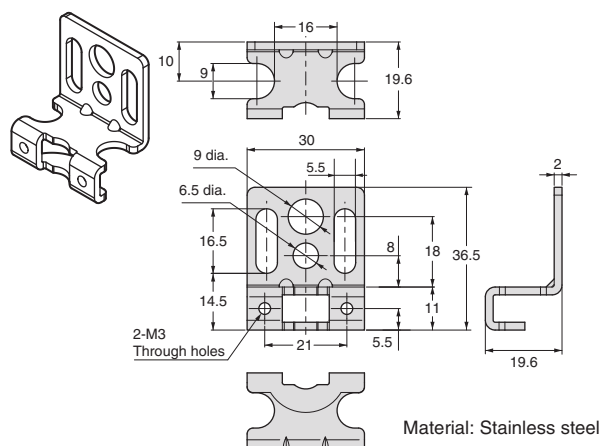

Using Side Flat Mounting Bracket (F39-LJ2)

F39-LJ2

Material: Stainless steel

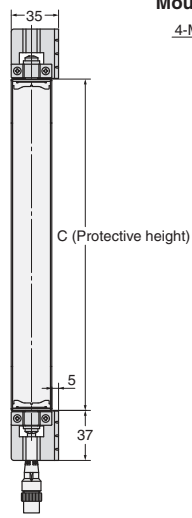
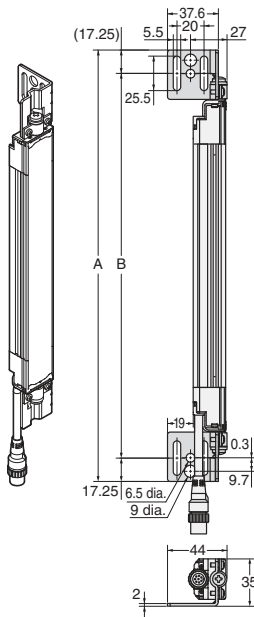
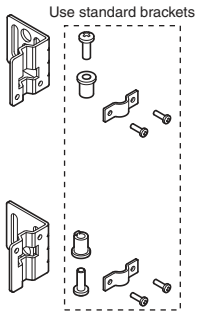

Mounting screw holes



Dimensions A to C

A	C + 74
B	C + 39.5
C	4-digit number of the model name (protective height)

Using Free Location Mounting Bracket (F39-LJ3)

Backside mounting

F39-LJ3

Material: Zinc die-cast
Horizontal angle: $\pm 10^\circ$

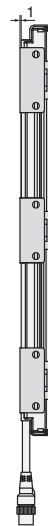
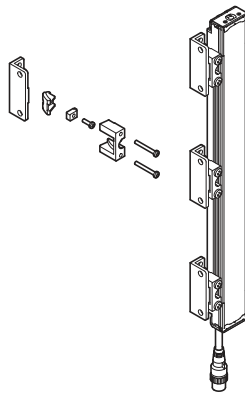

Mounting screw holes

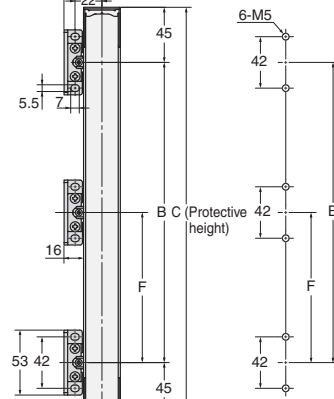

Side mounting

F39-LJ3

Material: Zinc die-cast/
stainless
Horizontal angle: $\pm 10^\circ$

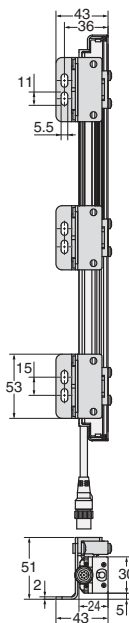
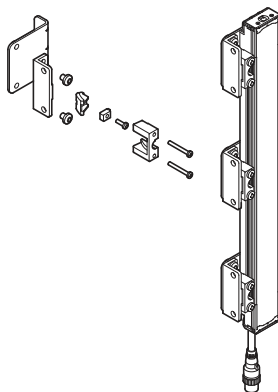

Mounting screw holes

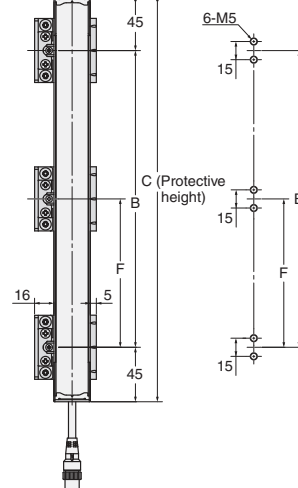

Dimensions B, C, and F

B	C - 90
C	4-digit number of the model name (protective height)
F	Depends on the protective height. See the table on the right.

Dimensions F

Protective height	Number of intermediate brackets	F *
245 to 440	2	---
443 to 785	3	B/2
794 to 1,140	4	B/3
1,145 to 1,490	5	B/4
1,495 to 1,840	6	B/5
1,845 to 2,180	7	B/6
2,195 to 2,500	8	B/7

*Use F = 350 or less when none of the F values shown above are used.

When only F39-LJ3 free-location mounting brackets are used without standard brackets, allow a space of at least 350 mm between the brackets. The number of brackets required varies according to the protective height. For details about the number of required brackets, refer to the table below.

The standard included intermediate brackets are the same as the F39-LJ3 free-location mounting brackets. Purchase brackets as necessary if there are fewer intermediate brackets than required. When intermediate brackets are included, they can be used as free-location mounting brackets.

Required number of F39-LJ3 free-location mounting brackets for 1 F3SJ set (emitter/receiver) (2 pieces are included with F39-LJ3)

Protective height	Number of included free location brackets as intermediate brackets	Number of free location brackets to mount F3SJ	Number of free location bracket sets to be purchased (pcs)
245 to 440	0	4	2 sets (4)
443 to 596	0	6	3 sets (6)
600 to 785	2	6	2 sets (4)
794 to 1,130	2	8	3 sets (6)
1,136 to 1,140	4	8	2 sets (4)
1,145 to 1,490	4	10	3 sets (6)
1,495 to 1,658	4	12	4 sets (8)
1,660 to 1,840	6	12	3 sets (6)
1,845 to 2,180	6	14	4 sets (8)
2,195 to 2,500	8	16	4 sets (8)

Using Top/Bottom Bracket B (F39-LJ4)

Backside mounting

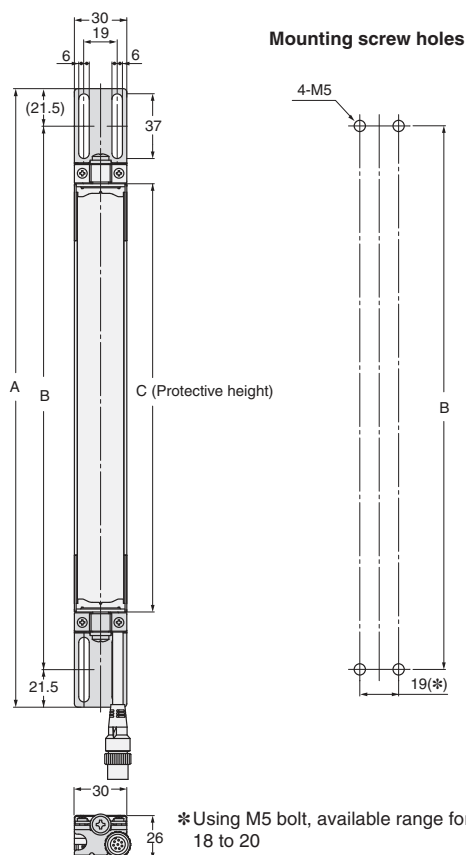
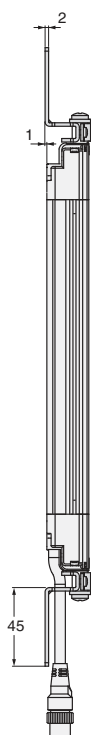
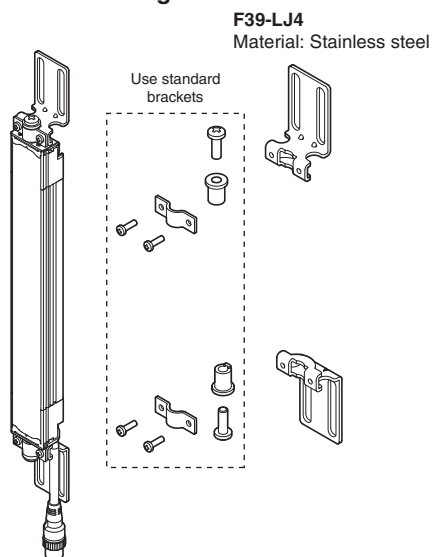

Dimensions A to C

A	C + 109
B	C + 66
C	4-digit number of the model name (protective height)

Note: Refer to the User's Manual for the dimensions for side mounting.

Using Top/Bottom Bracket C (F39-LJ11)

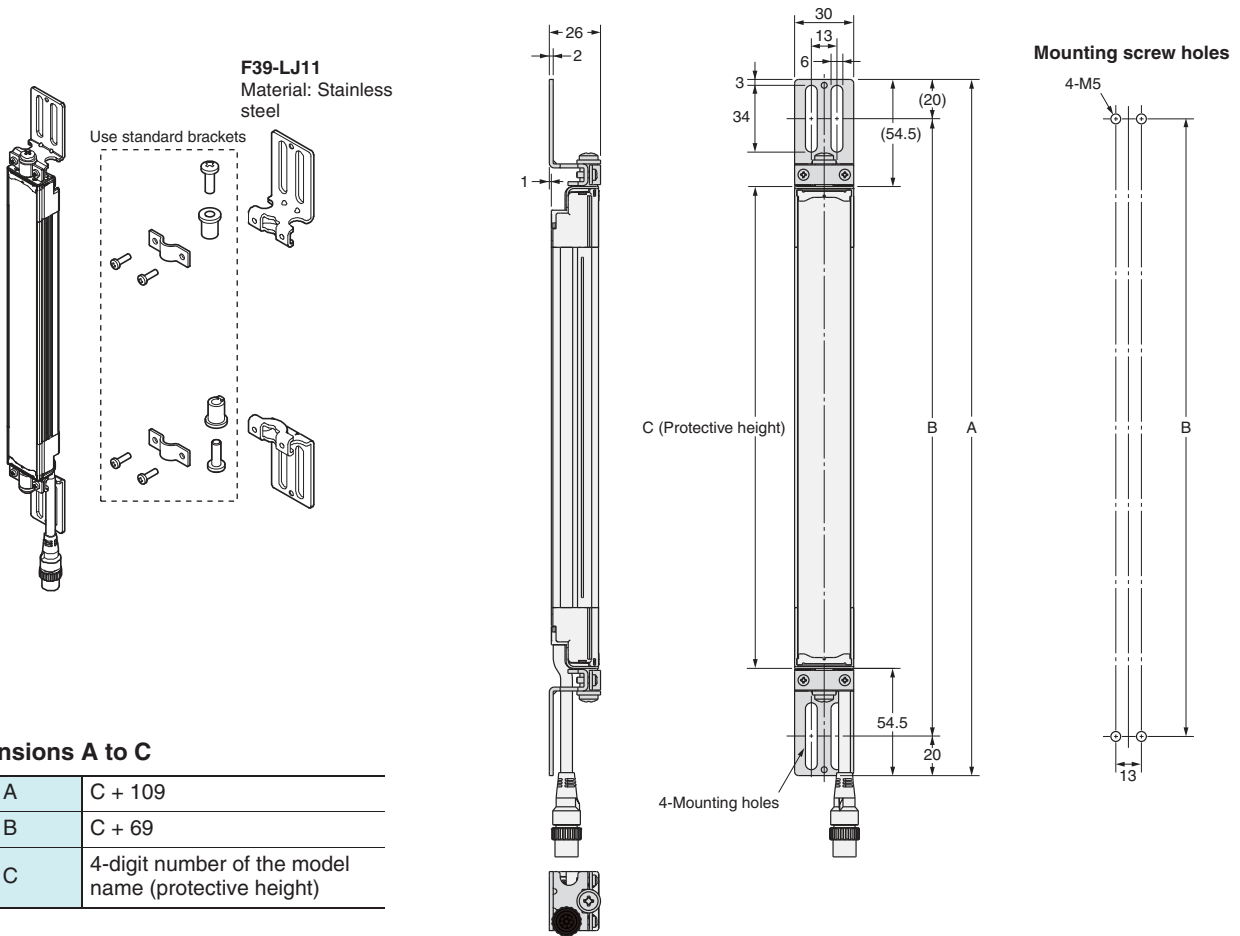

Using Space-saving Mounting Bracket (F39-LJ8)

Backside mounting

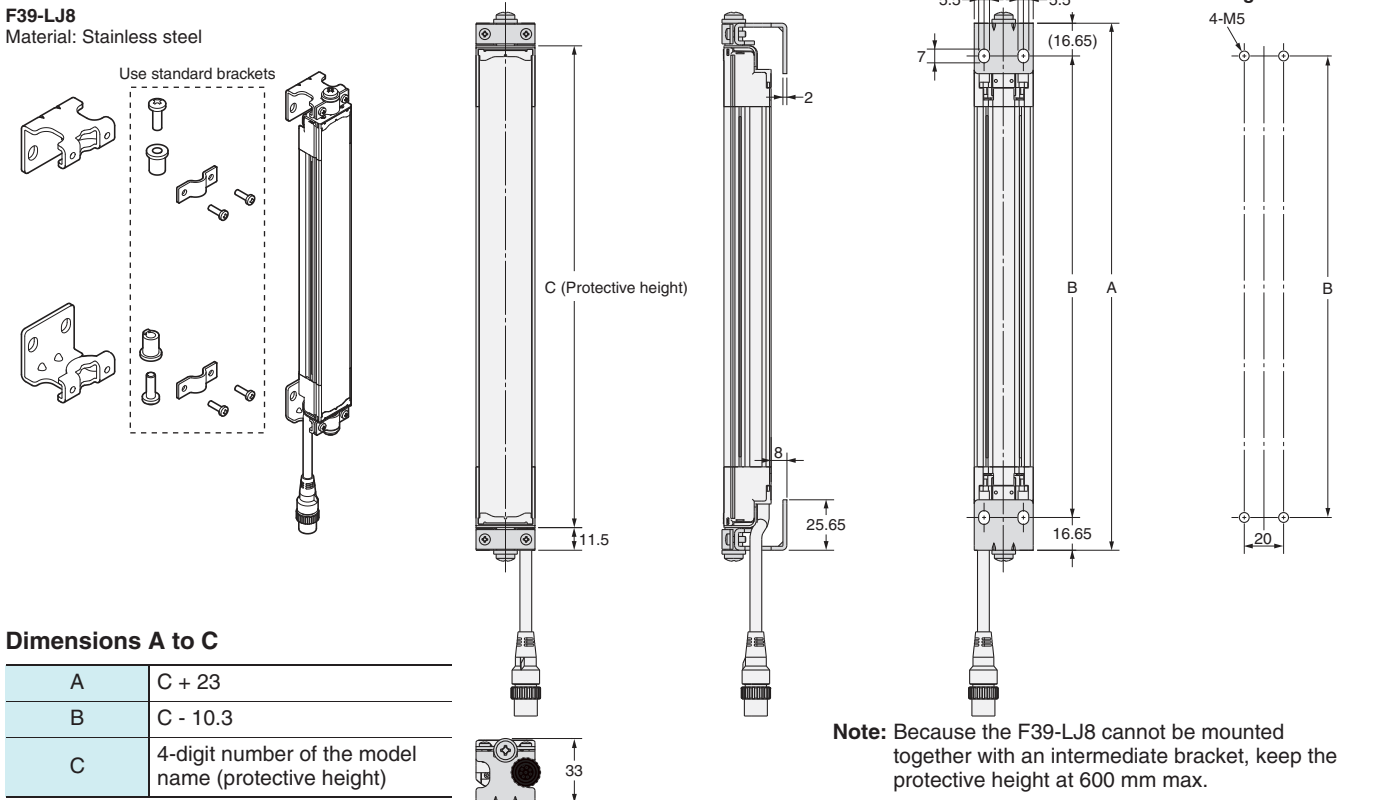

Guide to Replacing F3SJ-A with F3SJ-E/B (Including models whose production will be discontinued)

F3SJ-A to F3SJ-E/B replacement correspondence table (F3SJ-A mounting holes can be used without modification)

To check available brackets for replacement, refer to the table below.

To check dimensions when mounting brackets, refer to page 93.

The values in the table correspond to in the model name, meaning the protective height (mm) of a sensor.

F3SJ-A			Replacement F3SJ-E/B	Available bracket for replacement	
□□□□P(N)20	□□□□P(N)25	□□□□P(N)30	□□□□P(N)25	Top/bottom bracket (F39-LJB1)	Compatible bracket (F39-LJB4)
0245 0260 0275 0290	0260 0280	0245 0270 0295	0225		✓
	0300			✓	✓
0305 0320 0335 0350 0365	0320 0340 0360	0320 0345 0370	0305		✓
0380	0380			✓	✓
0395 0410 0425 0440 0455	0400 0420 0440	0395 0420 0445	0385		✓
	0460			✓	✓
0470 0485 0500 0515 0530	0480 0500 0520	0470 0495 0520	0465		✓
	0540			✓	✓
0545 0560 0575 0590 0605	0560 0580 0600	0545 0570 0595	0545		✓
0620	0620	0620		✓	✓
0635 0650 0665 0680 0695	0640 0660 0680	0645 0670 0695	0625		✓
	0700			✓	✓
0710 0725 0740 0755 0770	0720 0740 0760	0720 0745 0770	0705		✓
	0780			✓	✓
0785 0800 0815 0830 0845	0800 0820 0840	0795 0820 0845	0785		✓
0860	0860			✓	✓
0875 0890 0905 0920 0935	0880 0900 0920	0870 0895 0920	0865		✓
	0940			✓	✓
0950 0965 0980 0995 01010	0960 0980 01000	0945 0970 0995	0945		✓
	1020	1020		✓	✓
1025 1040 1055 1070 1085 1100	1040 1060 1080	1045 1070 1095	1025		✓
	1100			✓	✓
1115 1130 1145 1160 1175	1120 1140 1160	1120 1145 1170	1105		✓

F3SJ-A

F3SJ-A			Replacement F3SJ-B	Available bracket for replacement	
□□□□P(N)20	□□□□P(N)25	□□□□P(N)30	□□□□P(N)25	Top/bottom bracket (F39-LJB1)	Compatible bracket (F39-LJB4)
	1180		1185	✓	✓
1190	1200	1195			
1205	1220	1220			
1220	1240	1245			✓
1235					
1250					
	1260		1265	✓	✓
1265	1280	1270			
1280	1300	1295			
1295	1320	1320			✓
1310					
1325					
1340	1340		1345	✓	✓
1355	1360	1345			
1370	1380	1370			
1385	1400	1395			✓
1400					
1415					
	1420	1420	1425	✓	✓
1430	1440	1445			
1445	1460	1470			
1460	1480	1495			✓
1475					
1490					
	1500		1505	✓	✓
1505	1520	1520			
1520	1540	1545			
1535	1560	1570			✓
1550					
1565					
1580	1580		1585	✓	✓
1595	1600	1595			
1610	1620	1620			
1625	1640	1645			✓
1640					
1655					
	1660		1665	✓	✓
1670	1680	1670			
1685	1700	1695			
1700	1720	1720			✓
1715					
1730					
	1740		1745	✓	✓
1745	1760	1745			
1760	1780	1770			
1775	1800	1795			✓
1790					
1805					
1820	1820	1820	1825	✓	✓
1835	1840	1845			
1850	1860	1870			
1865	1880	1895			✓
1880					
1895					
	1900		1905	✓	✓
1910	1920	1920			
1925	1940	1945			
1940	1960	1970			✓
1955					
1970					
	1980		1985	✓	✓
1985	2000	1995			
2000	2020	2020			
2015	2040	2045			✓
2030					
2045					
2060	2060		2065	✓	✓
2075	2080	2070			
2090	2100	2095			
2105	2120	2120			✓
2120					
2135					

Note: 1. Protective height and detection capability vary according to replacement. Check the safe design of your device before use.
 2. The maximum protective height of F3SJ-E is 1,105 mm. Only the F3SJ-B can be replaced for the protective height of 1,185 or more.

Change of Dimensions due to Replacement

(1) Replacement by backside mounting

	F3SJ-A (Using standard bracket)	F3SJ-E/B (Top/bottom bracket used)	F3SJ-E/B (Compatible bracket used)
Dimensions (mm) from mounting wall surface to optical surface (mm)	26	43	43
Total length including bracket (mm)	Protective height + 74	Protective height + 69	Protective height + 159

Dimensional drawing from mounting wall surface to optical surface



(2) Replacement by side mounting

	F3SJ-A (Using standard bracket)	F3SJ-E/B (Top/bottom bracket used)	F3SJ-E/B (Compatible bracket used)
Dimensions of a protrusion from mounting wall (mm)	51	46	46
Total length including bracket (mm)	Protective height +74	Protective height +69	Protective height +159

Dimensional drawing of a protrusion from mounting wall



Replacement using intermediate brackets

For backside mounting, the F3SJ-A and F3SJ-E/B can be used without modification due to compatibility in mounting hole pitch. For side mounting, a new hole needs to be made due to the different mounting hole pitch.

Mounting hole pitch for side mounting using intermediate bracket

	F3SJ-A (Free-location bracket used)	F3SJ-E/B (Intermediate bracket used)
Mounting hole pitch (mm)	15	42

Dimensional drawing of mounting hole for side mounting using intermediate bracket

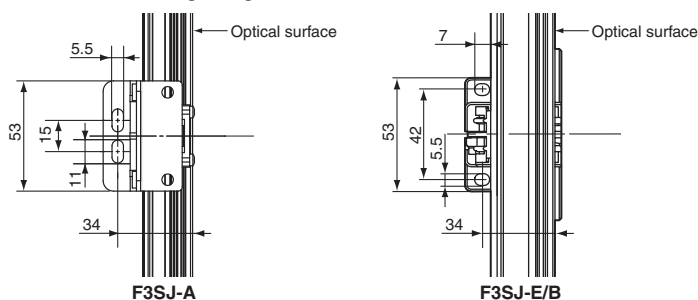

Change of Dimensions due to Replacement

	F3SJ-A (Free-location bracket used)	F3SJ-E/B (Intermediate bracket used)
Dimensions (mm) from mounting wall surface to optical surface (mm)	26	43

Using mounting bracket for short-length F3SN (F39-LJ5)

Inward-facing mounting

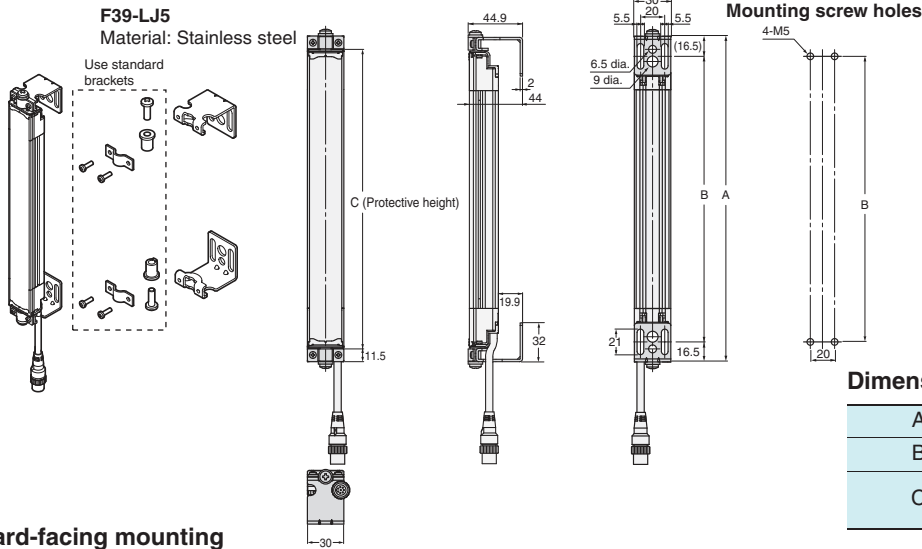

Outward-facing mounting

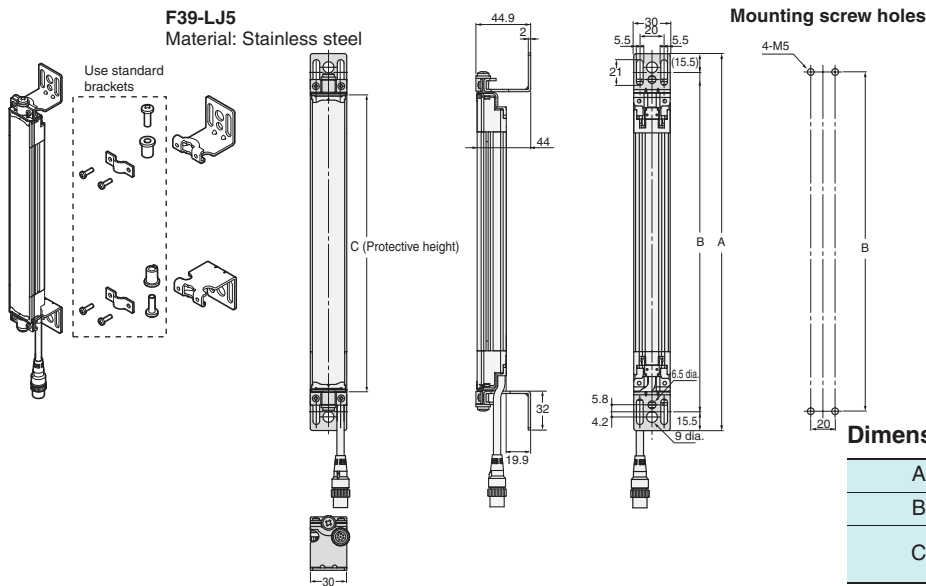

Inward + outward-facing mounting

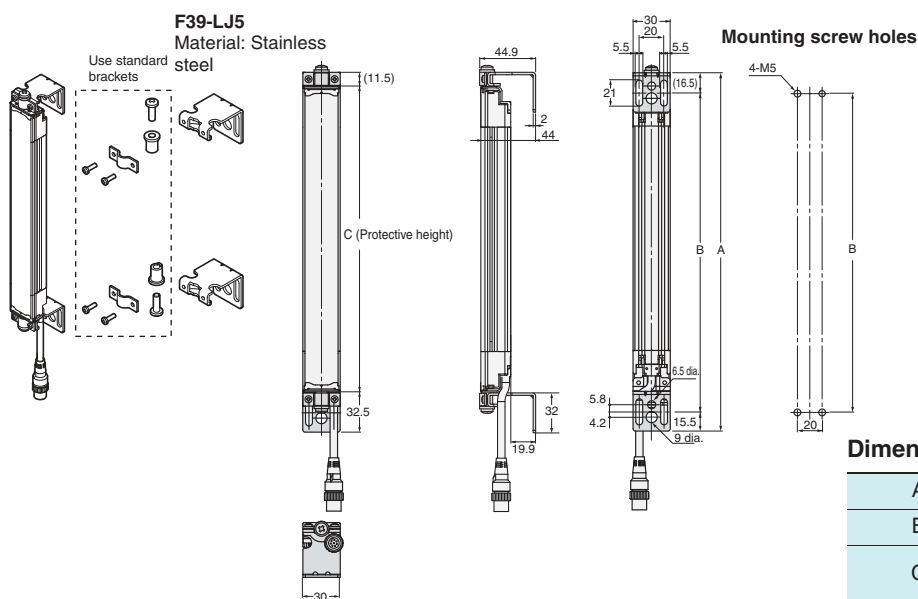

Accessories

Single-Ended Cable

- F39-JD3A (L = 3 m)
- F39-JD7A (L = 7 m)
- F39-JD10A (L = 10 m)

- F39-JD15A (L = 15 m)
- F39-JD20A (L = 20 m)

Cable color: Gray for emitter
Black for receiver

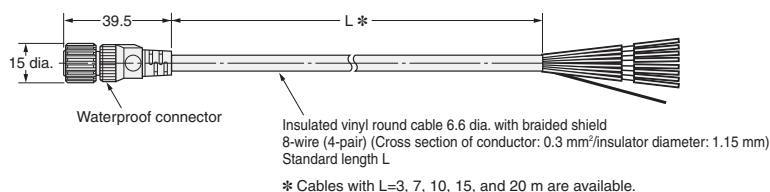

Double-Ended Cable

- F39-JDR5B (L = 0.5 m)
- F39-JD1B (L = 1 m)
- F39-JD3B (L = 3 m)
- F39-JD5B (L = 5 m)

- F39-JD7B (L = 7 m)
- F39-JD10B (L = 10 m)
- F39-JD15B (L = 15 m)
- F39-JD20B (L = 20 m)

Cable color: Gray for emitter
Black for receiver

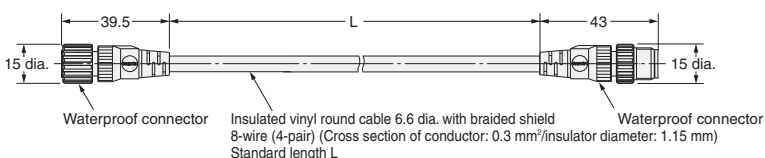

Simple Wiring Connector

F39-CN5

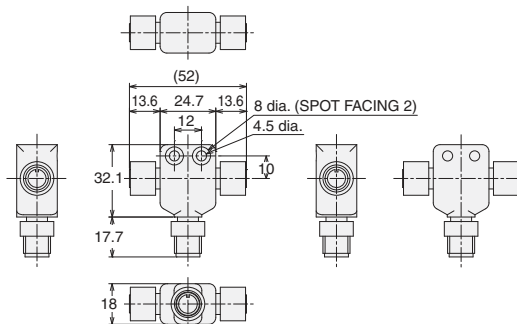

Control Unit

F3SP-B1P

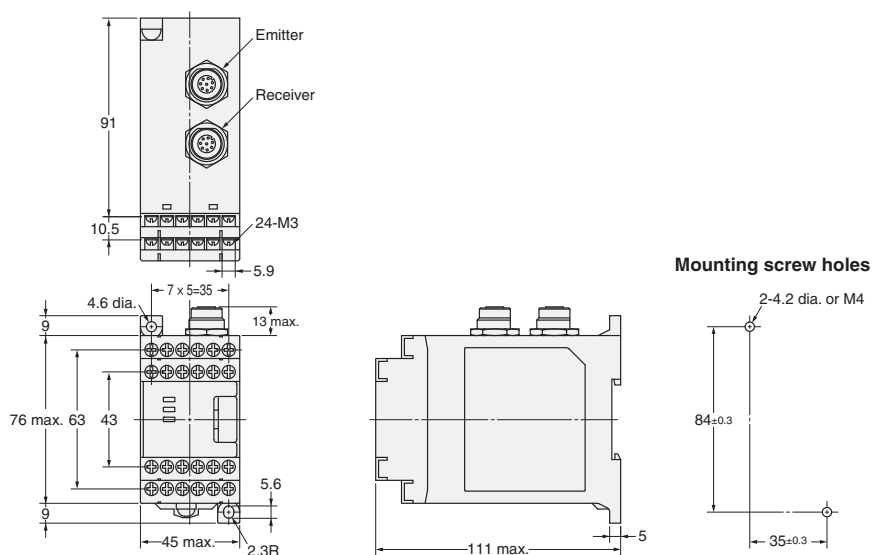

Laser Pointer

F39-PTJ

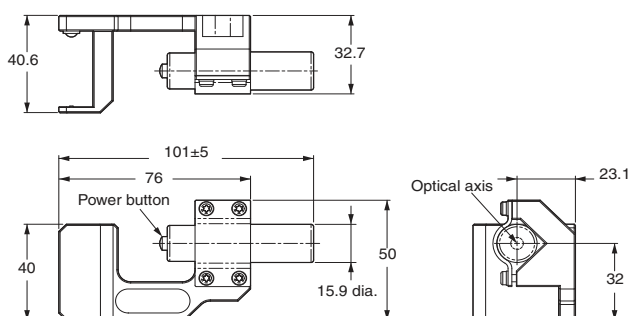

F3SJ-A

Dedicated External Indicator Set

F39-A01□-PAC

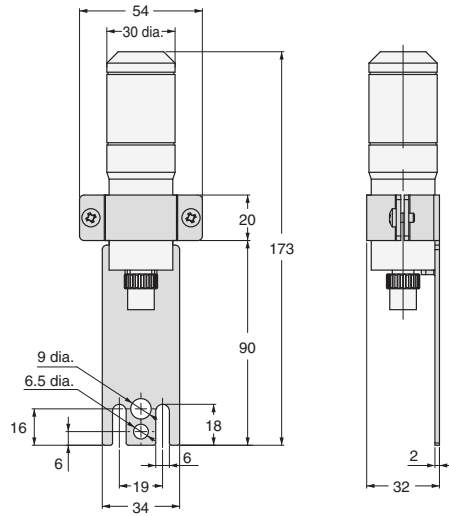

Material: Stainless steel

Spatter Protection Cover

F39-HJ□□□□

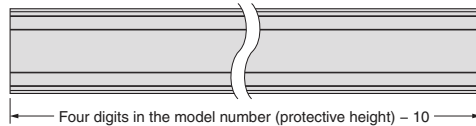
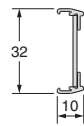

Assembled dimensions

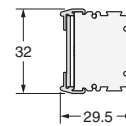

Material: PC (transparent area)
ABS (non-transparent area)

Mirrors

F39-MLG□

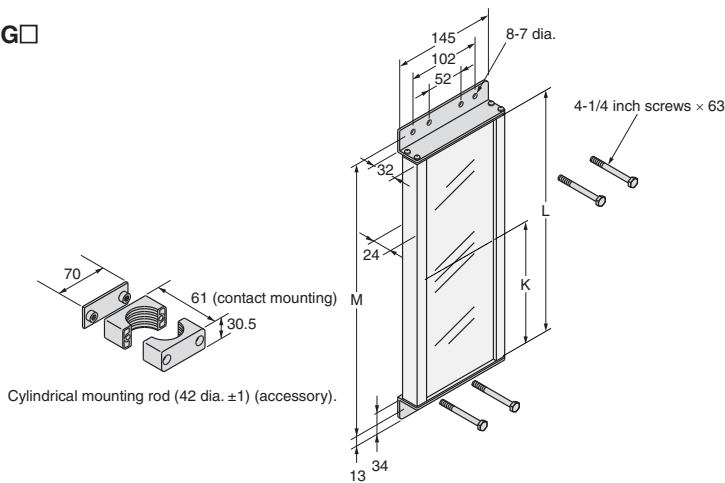

Model	L (mm)	M (mm)	K (mm)
F39-MLG0406	445	487	---
F39-MLG0610	648	690	---
F39-MLG0711	749	792	---
F39-MLG0914	953	995	---
F39-MLG1067	1,105	1,148	---
F39-MLG1219	1,257	1,300	---
F39-MLG1422 *	1,499	1,541	749
F39-MLG1626 *	1,702	1,744	851
F39-MLG1830 *	1,905	1,948	952
F39-MLG2134 *	2,210	2,252	1,054

* Following May 2018 production, products will include a two-piece mirror. "K" indicates the distance to the mirror seam.

Setting Support Software for the F3SJ

F39-GWUM

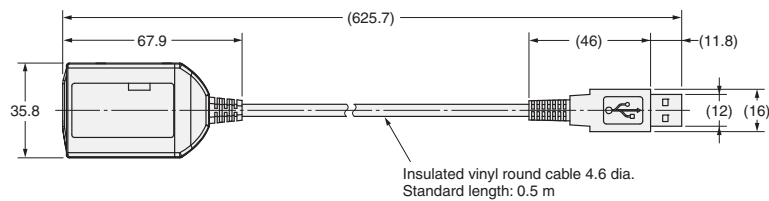

Protective Bar

F39-PJ□□□□-S

Backside mounting

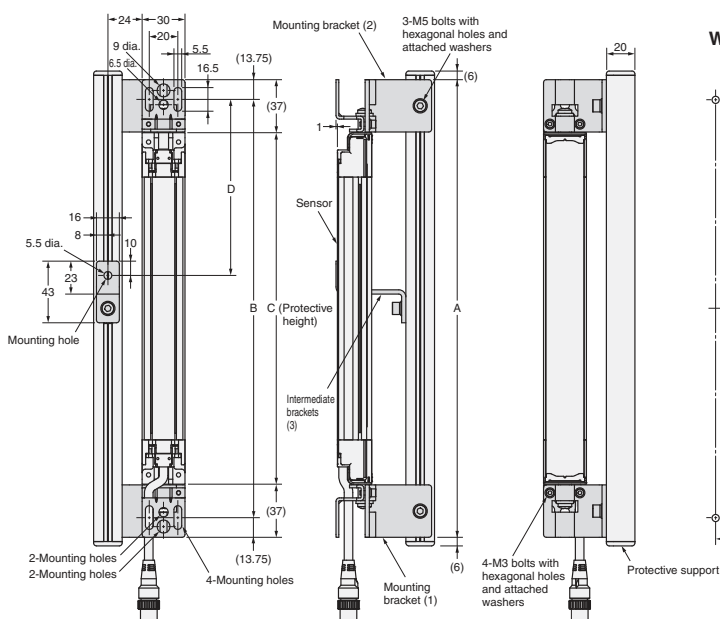

Mounting screw holes

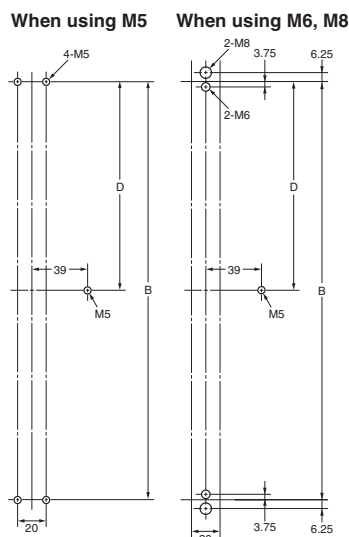

C (protective height): 4-digit number in the table
 $A = C + 74$,
 $B = C + 46.5$

Protective height	Number of intermediate brackets used (3)	D
245 to 995	0	---
1,001 to 2,000	1	B/2
2,009 to 2,500	2	B/3

Note: For reference, D is the dimension that will not interfere with the intermediate bracket on the Safety Light Curtain body.

Side mounting

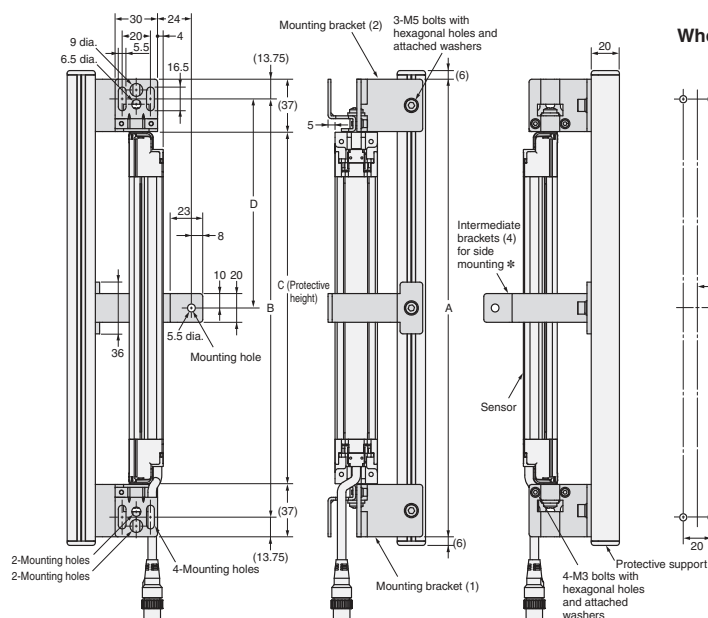

Mounting screw holes

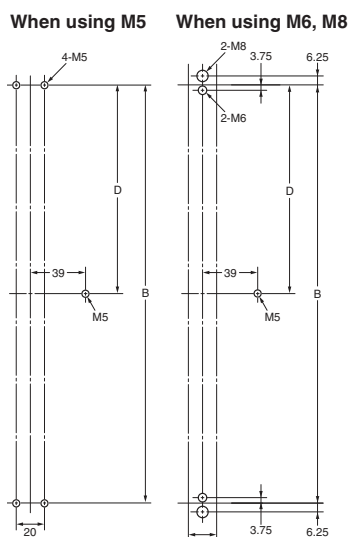

C (protective height): 4-digit number in the table
 $A = C + 74$,
 $B = C + 46.5$

Protective height	Intermediate brackets for side mounting Number of intermediate brackets used (4)	D
245 to 995	0	---
1,001 to 2,000	1	B/2
2,009 to 2,500	2	B/3

Note: For reference, D is the dimension that will not interfere with the intermediate bracket on the Safety Light Curtain body.

*The four intermediate brackets (F39-PJ-MS) for side mounting are not provided.

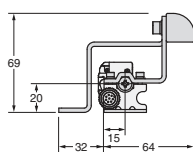

F3SJ-A

Water-resistant Case

F39-EJ□□□□-L(D) Backside mounting

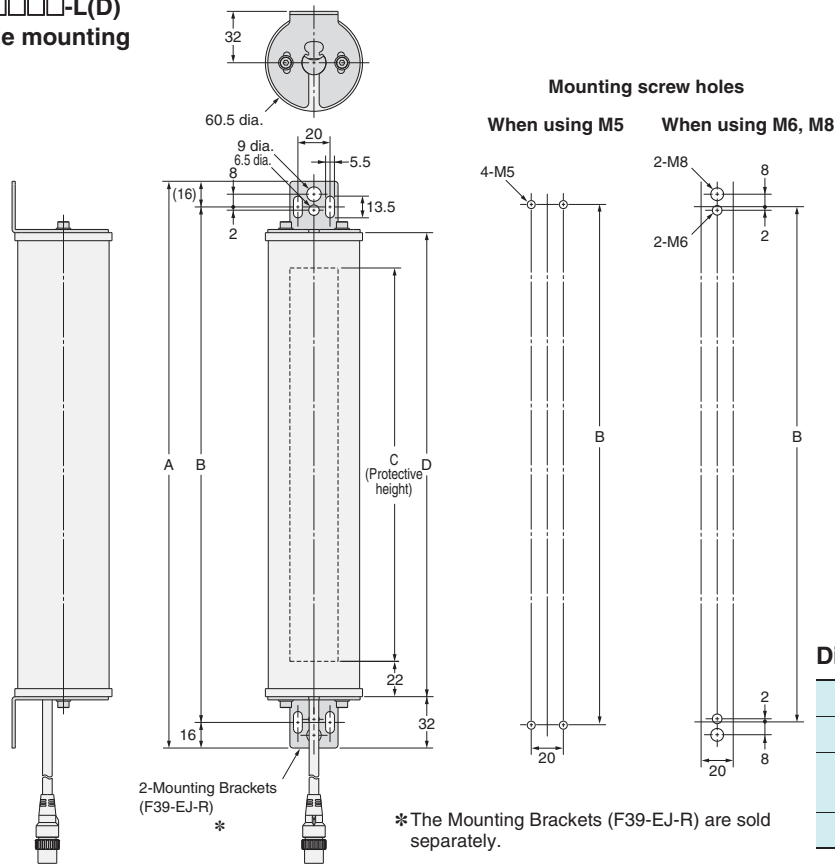

Dimensions A to D

A	C + 108
B	C + 76
C	4-digit number of the model name (protective height)
D	C + 44

Side mounting

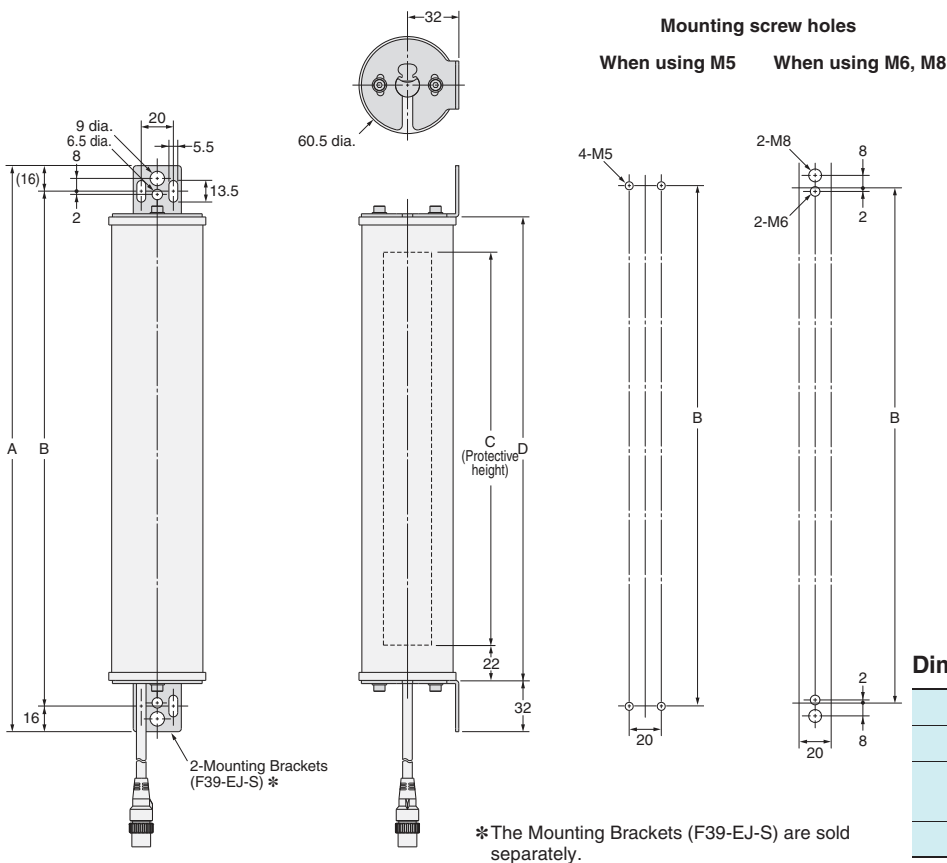

Dimensions A to D

A	C + 108
B	C + 76
C	4-digit number of the model name (protective height)
D	C + 44