

User Guide
6642-22401

©Westermo Teleindustri AB

DDW-226

WOLVERINE SERIES

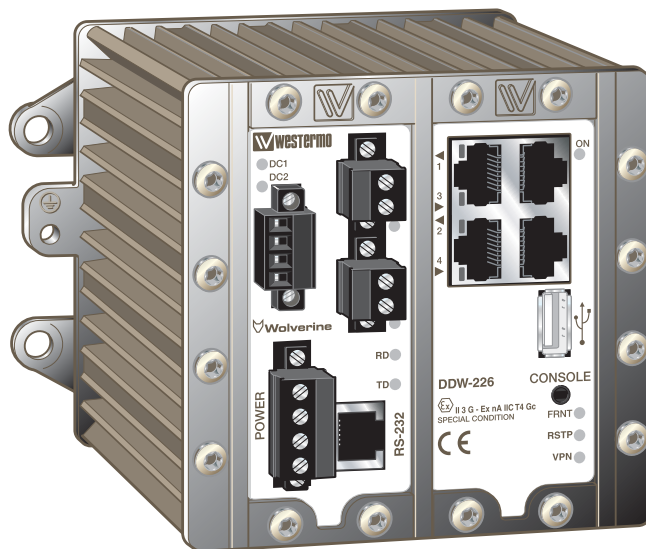

 **Wolverine**
*Industrial Ethernet
SHDSL extender*



License Information

This device contains public available software which is under the GPL lincense.
For more information see legal.pdf included with all firmware releases.

This product includes software developed by the OpenSSL Project for use in the
OpenSSL Toolkit, <http://www.openssl.org>

Legal information

The contents of this document are provided "as is". Except as required by applicable law, no warranties of any kind, either express or implied, including, but not limited to, the implied warranties of merchantability and fitness for a particular purpose, are made in relation to the accuracy and reliability or contents of this document. Westermo reserves the right to revise this document or withdraw it at any time without prior notice.

Under no circumstances shall Westermo be responsible for any loss of data or income or any special, incidental, and consequential or indirect damages howsoever caused.

More information about Westermo can be found at the following Internet address:

<http://www.westermo.com>

Safety



Before installation:

Read this manual completely and gather all information on the unit. Make sure that you understand it fully. Check that your application does not exceed the safe operating specifications for this unit.

This unit should only be installed by qualified personnel.

This unit must be properly connected to the installation protective ground for safety and functional reasons.

This unit should be built-in to an apparatus cabinet, or similar, where access is restricted to service personnel only.

The power supply wiring must be sufficiently fused, and if necessary it must be possible to disconnect manually from the power supply. Ensure compliance to national installation regulations.

This unit uses convection cooling. To avoid obstructing the airflow around the unit, follow the spacing recommendations (see Cooling section).



Before mounting, using or removing this unit:

Prevent access to hazardous voltage by disconnecting the unit from power supply.

Warning! Do not open connected unit. Hazardous voltage may occur within this unit when connected to power supply.

Care recommendations

Follow the care recommendations below to maintain full operation of unit and to fulfil the warranty obligations.

This unit must not be operating with removed covers or lids.

Do not attempt to disassemble the unit. There are no user serviceable parts inside.

Do not drop, knock or shake the unit, rough handling above the specification may cause damage to internal circuit boards.

Do not use harsh chemicals, cleaning solvents or strong detergents to clean the unit.

Do not paint the unit. Paint can clog the unit and prevent proper operation.

Do not expose the unit to any kind of liquids (rain, beverages, etc). The unit is not waterproof. Keep the unit within the specified humidity levels.

Do not use or store the unit in dusty, dirty areas, connectors as well as other mechanical part may be damaged.

If the unit is not working properly, contact the place of purchase, nearest Westermo distributor office or Westermo Tech support.

A readily accessible disconnect device shall be incorporated external to the equipment.

This unit may have hot surfaces when used in high ambient temperature.



ATEX Information

General

This unit is intended to be used in Zone 2 hazardous location only.

Marking

 II 3 G - Ex nA IIC T4 Gc

SPECIAL CONDITION

	The Ex mark is a specific marking for explosive protection equipment. The mark shows that this unit complies with the requirements of the relevant European standards that are harmonised with the 94/9/EC Directive.
II	Equipment group II. This unit can be installed in all places with an explosive gas atmosphere other than mines susceptible to firedamp.
3	Category 3, a category is a classification according to the required level of protection. Equipment in this category ensures the requisite level of protection during normal operation and is intended for use in areas in which explosive atmosphere caused by gases, vapours, mists are unlikely to occur or, if they do occur, are likely to do so only infrequently and for a short period only.
G	The letter "G" indicates the protection concerning explosive atmospheres caused by gases, vapours or mists.
Ex	Shows that this unit is in conformity with relevant European Ex standards.
nA	Type of protection applied to electrical equipment to avoid ignition of a surrounding explosive atmosphere. This unit is a non-sparking device "nA" which is constructed to minimize the risk of occurrence of arcs or sparks capable of creating an ignition hazard during conditions of normal operation.
IIC	IIC is the gas group, a typical gas is hydrogen.
T4	Temperature class T4 (T4 = 135°C). This unit is classified in accordance with its maximum surface temperature (external and internal).
Gc	Equipment protection level Gc (EPL Gc). Equipment for explosive gas atmospheres, having a "enhanced" level of protection, which is not a source of ignition in normal operation and which may have some additional protection to ensure that it remains inactive as an ignition source in the case of regular expected occurrences. EPL Gc are analogous to the ATEX Categories (Category 3 G = EPL Gc).
SPECIAL CONDITON	This unit have special condition for use. The special conditon for use contains safety related information that is necessary for the correct installation and safe use.

Warning markings

WARNING – DO NOT SEPARATE WHEN ENERGIZED

Ratings

Power	(20 – 48) VDC; 330 mA
Ambient temperature	-40 °C ≤ Tamb ≤ +70°C
Ingress protection (IP)	IP40
Maximum surface temperatur	135°C (temperatur class T4)

Special condition for use

Ambient temperature:

This unit is designed for use in extreme ambient temperature conditions according to the following: $-40^{\circ}\text{C} \leq T_{\text{amb}} \leq +70^{\circ}\text{C}$

Installation in an apparatus cabinet:

This unit requires installation in an apparatus cabinet which holds a degree of protection of at least IP54 and either complies with EN 60079-0 and EN 60079-15 or is an Ex e-, Ex d-, Ex p-, Ex o- or Ex q certified apparatus cabinet.

Resistance to impact:

This unit requires installation in an apparatus cabinet where adequate resistance to impact is provided by the apparatus cabinet. See "Installation in an apparatus cabinet" above for requirements on the external apparatus cabinet.

Resistance to light:

This unit requires installation in an apparatus cabinet where it is protected from light (for example daylight or light from luminaires). See "Installation in an apparatus cabinet" above for requirements on the external apparatus cabinet.

Transient protection:

This unit requires transient protection external to the power supply terminals to be set at a level not exceeding 67 VDC.

Conductor temperature:

When this unit is installed in locations with high ambient temperature, special precautions shall be taken upon the choice of external conductors and the temperature rating of the conductors.

Directive 94/9/EC alongside with other directives:

Directive 2004/108/EC (EMC) applies and to assure a safe performance of this unit under the scope of Directive 94/9/EC, refer to the electromagnetic immunity level specified under Type tests and environmental conditions in this manual.

Standards and date of compliance

EN 60079-0 and EN 60079-15
2010-05-01

Agency approvals and standards compliance

Type	Approval / Compliance
EMC	EN 55024, EN 55024 A1, EN 55024 A2, Electromagnetic compatibility – Immunity IT equipment
	EN 55022, EN 55022 A1, Information technology equipment. Radio disturbance characteristics. Limits and methods of measurement
	EN 61000-6-2, Immunity industrial environments
	EN 61000-6-4, Emission industrial environments
	EN 61000-6-3, Emission residential, commercial and light-industrial environments
	FCC part 15 Class A and Class B
	EN 50121-4, Railway signalling and telecommunications apparatus
Safety	EN 60950-1, IT equipment
SHDSL	ITU-T G.991.2
ATEX	EN 60079-0 and EN 60079-15

FCC Part 15.105 Notice:

This equipment has been tested and found to comply with the limits for a Class B digital device, pursuant to Part 15 of the FCC Rules. These limits are designed to provide reasonable protection against harmful interference in a residential installation. This equipment generates, uses and can radiate radio frequency energy and, if not installed and used in accordance with the instructions, may cause harmful interference to radio communications. However, there is no guarantee that interference will not occur in a particular installation. If this equipment does cause harmful interference to radio or television reception, which can be determined by turning the equipment off and on, the user is encouraged to try to correct the interference by one or more of the following measures:

- ⌘ Reorient or relocate the receiving antenna
- ⌘ Increase the separation between the equipment and receiver
- ⌘ Connect the equipment into an outlet on a circuit different from that to which the receiver is connected
- ⌘ Consult the dealer or an experienced radio/TV technician for help.

Declaration of Conformity



Westermo Teleindustri AB

Declaration of conformity

The manufacturer Westermo Teleindustri AB
SE-640 40 Stora Sundby, Sweden

Herewith declares that the product(s)

Type of product	Model	Art no	From serial no.
DIN-rail	Wolverine DDW-225	3642-0230	1000
DIN-rail	Wolverine DDW-225	3642-0250	1000
DIN-rail	Wolverine DDW-226	3642-0240	1000

is in conformity with the following EC directive(s).

No	Short name
2004/108/EC	Electromagnetic Compatibility (EMC)
94/9/EC	Equipment explosive atmosphere (ATEX)

References of standards applied for this EC declaration of conformity.

No	Title	Issue
EN 61000-6-2	Immunity for industrial environments	2005
EN 61000-6-1	Immunity for residential, commercial and light-industrial environments	2007
EN 55024 EN 55024 A1 EN 55024 A2	Information technology equipment – Immunity	1998 2001 2003
EN 55022 EN 55022 A1	Information technology equipment. Radio disturbance characteristics. Limits and methods of measurement.	2006 2007
EN 50121-4	Railway applications – Electromagnetic compatibility – Emission and Immunity of the signalling and telecommunications apparatus	2006
EN 61000-6-4	Emission standard for industrial environments	2007
EN 61000-6-3	Emission standard for residential, commercial and light-industrial environments	2007
EN 60079-0	Explosive atmospheres - Equipment - General requirements	2009
EN 60079-15	Electrical apparatus for explosive gas atmospheres - Construction, test and marking of type of protection "n" electrical apparatus	2005

The last two digits of the year in which the CE marking was affixed: 10

Signature

Pierre Öberg
Technical Manager
3rd May 2010

Postaddress/Postal address
S-640 40 Stora Sundby
Sweden

Tel.
016-428000
Int+46 16428000

Telefax
016-428001
Int+46 16428001

Postgiro
52 72 79-4

Bankgiro
5671-5550

Org.nr/
Corp. identity number
556361-2604

Registered office
Eskilstuna

Type tests and environmental conditions

Phenomena	Test	Description	Test levels
ESD	EN 61000-4-2	Enclosure contact	± 6 kV
		Enclosure air	± 8 kV
RF field AM modulated	IEC 61000-4-3	Enclosure	10 V/m 80% AM (1 kHz), 80 – 1000 MHz 20 V/m 80% AM (1 kHz), 800 – 1000 MHz 10 V/m 80% AM (1 kHz), 1400 – 2100 MHz 5 V/m 80% AM (1 kHz), 2100 – 2500 MHz 1 V/m 80% AM (1 kHz), 2500 – 2700 MHz
Fast transient	EN 61000-4-4	Signal ports	± 2 kV
		Power ports	± 2 kV
Surge	EN 61000-4-5	Signal ports unbalanced	± 2 kV line to earth, ± 2 kV line to line
		Signal ports balanced	± 2 kV line to earth, ± 1 kV line to line
		Power ports	± 2 kV line to earth, ± 1 kV line to line
RF conducted	EN 61000-4-6	Signal ports	10 V 80% AM (1 kHz), 0.15 – 80 MHz
		Power ports	10 V 80% AM (1 kHz), 0.15 – 80 MHz
Power frequency magnetic field	EN 61000-4-8	Enclosure	300 A/m
Pulse magnetic field	EN 61000-4-9	Enclosure	300 A/m
Mains freq. 50 Hz	EN 61000-4-16	Signal ports	100 V 50 Hz line to earth
Mains freq. 50 Hz	SS 436 15 03	Signal ports	250 V 50 Hz line to line
Voltage dips and interruption	EN 61000-4-29	DC power ports	10 & 100 ms, interruption 10 ms, 30% reduction 10 ms, 60% reduction +20% above & -20% below rated voltage
Radiated emission	EN 55022	Enclosure	Class A and Class B
	EN 55016-2-3	Enclosure	Class A and Class B
	FCC part 15	Enclosure	Class A and Class B
Conducted emission	EN 55022	DC power ports	Class A and Class B
Dielectric strength	EN 60950	Signal port to other isolated ports	1500 Vrms 50 Hz 1 min
		Power port to other isolated ports	1500 Vrms 50 Hz 1 min
Temperature		Operating	-40 to +70°C
		Storage & Transport	-40 to +85°C
		Maximum surface temperature	135°C (temperature class T4)
Humidity		Operating	5 to 95% relative humidity
		Storage & Transport	5 to 95% relative humidity
Altitude		Operating	2 000 m / 70 kPa
Reliability prediction (MTBF)	MIL-HDBK-217F	Operating	700 000 hours @ 25°C
Service life		Operating	10 year
Vibration	IEC 60068-2-6	Operating	7.5 mm, 5 – 8 Hz 2 g, 8 – 500 Hz
Shock	IEC 60068-2-27	Operating	15 g, 11 ms
Enclosure	UL 94	Aluminium/Zink	Flammability class V-0
Dimension W x H x D			134 x 105 x 122 mm
Weight			1.5 kg
Degree of protection	IEC 529	Enclosure	IP 40
Cooling			Convection
Mounting			Horizontal on 35 mm DIN-rail or wall-mounted

Description

DDW-226 is an Ethernet extender with integrated switch and support for legacy serial connections. It uses the Westermo WeOS operating system that provides the DDW-226 with all the advanced switching and routing functionality supported by the DDW-226. These functions include VLAN support, Layer 2/3 switching, Static Routing, Firewall functions, IGMP Snooping, VPN support.

A further enhancement the DDW-226 provides is a set of advanced diagnostic functions that allow the SHDSL line to be dynamically monitored allowing alarms to be configured to pre-warn of any performance issues. This monitoring data can be accessed in a number of ways; it can be read at any time through the Web Interface, Command Line Interface or via SNMP.

A key function of the DDW-226 is its ability to be used to create redundant ring networks over the SHDSL links, using both the Westermo FRNT protocol, but also RSTP.

- ⌘ Serial port
- ⌘ Up to 5.7 Mbit/s over old cables
- ⌘ Redundant ring on the SHDSL interface
- ⌘ Advanced Diagnostics
- ⌘ VLAN support and IGMP Snooping
- ⌘ VPN support

Interface specifications

Power	
Rated voltage	20 to 48 VDC
Operating voltage	16 to 60 VDC
Rated current	330 mA @ 20 VDC 150 mA @ 48 VDC
Rated frequency	DC
Inrush current, I ² t	1.5 A ² s
Startup current*	400 mA
Polarity	Reverse polarity protected
Redundant power input	Yes
Isolation to	All other
Connection	Detachable screw terminal
Connector size	0.2 – 2.5 mm ² (AWG 24 – 12)
Shielded cable	Not required

* External supply current capability for proper startup.

Console	
Electrical specification	TTL-level
Data rate	115.2 kbit/s
Data format	8 data bits, none parity, 1 stop bit, no flow control
Circuit type	SELV
Isolation to	All other except USB
Galvanic connection to	USB
Connection	2.5 mm jack, use Westermo cable 1211-2027

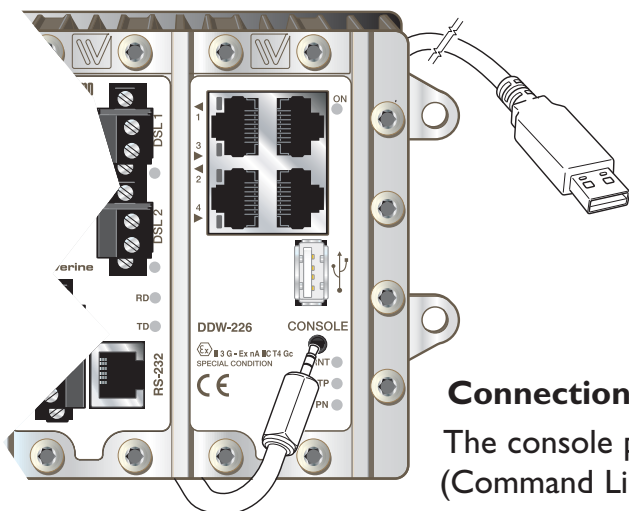

Connection to console port

The console port can be used to connect to the CLI (Command Line Interface).

The following steps needs to be taken

1. Connect the serial diagnostic cable to the console port (use only Westermo cable 1211-2027).
2. Connect cable to your computer (USB port, if drivers are needed they can be downloaded from our Web page).
3. Use a terminal emulator and connect with correct speed and format to the assigned port.

For more information about the CLI, see the WeOS management guide.

USB	
Electrical specification	USB 2.0 host interface
Data rate	Up to 12 Mbit/s (full-speed mode)
Circuit type	SELV
Maximum supply current	500 mA
Isolation to	All other except Console
Galvanic connection to	Console
Connection	USB receptacle connector type A
Conductive housing	Yes

I/O / Relay output	
Connect resistance	30 Ω
Isolation to	All other
Connection	Detachable screw terminal
Connector size	0.2 – 2.5 mm ² (AWG 24 – 12)
Maximum voltage/current	60 VDC / 80 mA
I/O / Digital input	
Voltage levels	Logic one >12V, Logic zero <1V
Isolation to	All other
Connection	Detachable screw terminal
Connector size	0.2 – 2.5 mm ² (AWG 24 – 12)

Ethernet TX	
Electrical specification	IEEE std 802.3. 2005 Edition
Data rate	10 Mbit/s or 100 Mbit/s, manual or auto
Duplex	Full or half, manual or auto
Circuit type	TNV-1
Transmission range	Up to 150 m with CAT5e cable or better
Isolation to	All other
Connection	RJ-45 auto MDI/MDI-X
Shielded cable	Not required, except when installed in Railway applications as signalling and telecommunications apparatus and located close to rails.*
Conductive housing	Yes
Number of ports	4

* To minimise the risk of interference, a shielded cable is recommended when the cable is located inside 3 m boundary or the cable is longer than 30 m and inside 10 m boundary to the rails and connected to this port.

SHDSL	
Electrical specification	ITU-T G.991.2 Annex B
Data rate	192 kbit/s to 5696 kbit/s
Protocol	EFM according to IEEE 802.3-2005
Transmission range	According to ITU-T G.991.2 depending on line quality
Isolation to	All other
Connection	Detachable screw terminal
Connector size	0.2 – 2.5 mm ² (AWG 24 – 12)
Shielded cable	Not required
Number of ports	2

RS-232	
Electrical specification	EIA RS-232
Data rate	300 bit/s – 115.2 kbit/s
Data format	7 or 8 data bits, odd/even/none parity, 1 or 2 stop bits
Protocol	Transparent, optimised by packing algorithm
Circuit type	SELV
Transmission range	15 m / 49 ft
Isolation to	Power, DSL, Ethernet
Galvanic connection to	USB, Console
Connection	RJ-45
Shielded cable	Not required
Conductive housing	Yes

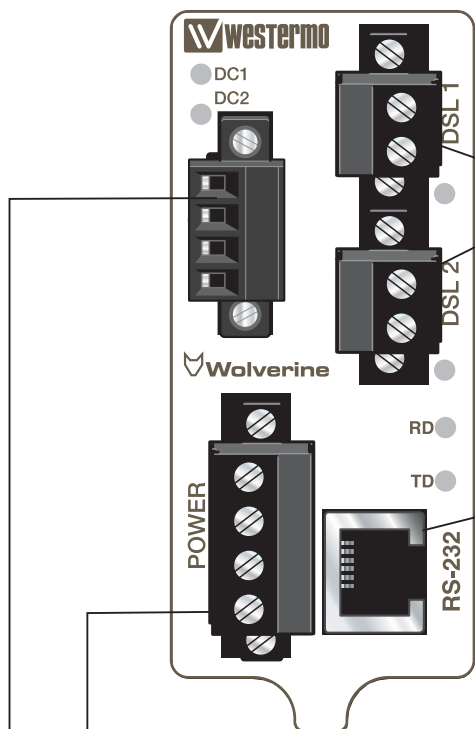

Position	Direction*	Description
1	In/Out	2-wire Receive/ Transmit SHDSL
2	In/Out	2-wire Receive/ Transmit SHDSL

* Direction relative this unit.

Position	Direction*	Description
1	Out	DSR (Data Set ready)
2	Out	DCD (Data Carrier Detect)
3	In	DTR (Data Terminal ready)
4	In/Out	SG (Signal Ground)
5	Out	RD (Receive Data)
6	In	TD (Transmit Data)
7	Out	CTS (Clear To Send)
8	In	RTS (Request To Send)
Shield	In/Out	Connected to PE

* Direction relative this unit.

Position	Direction*	Description	Product marking
1	In	+ Voltage A	+DC1
2	In	+ Voltage B	+DC2
3	In	Common	COM
4	In	Common	COM

* Direction relative this unit.

Position	Direction*	Description
1	Out	Relay output +
2	Out	Relay output -
3	In	Digital in +
4	In	Digital in -

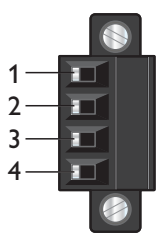

* Direction relative this unit.

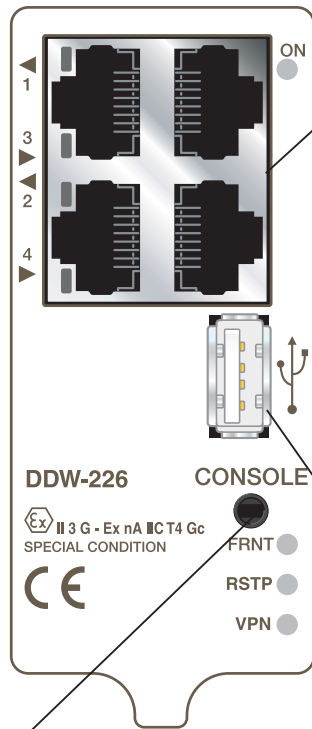

Console
(see more information
on page 10 and 11)

Position	Direction*	Description
1	In/Out	TD+
2	In/Out	TD-
3	In/Out	RD+
4	-	Not connected
5	-	Not connected
6	In/Out	RD-
7	-	Not connected
8	-	Not connected
Shield	In/Out	Connected to PE

* Direction relative this unit.

Position	Direction*	Description
1	Out	VBUS
2	In/Out	D-
3	In/Out	D+
4	Out	GND
Shield	In/Out	Connected to PE

* Direction relative this unit.

LED indicators

LED	Status	Description
ON	OFF	Unit has no power.
	GREEN	All OK, no alarm condition.
	RED	Alarm condition, or until unit has started up. (Alarm conditions are configurable, see "WeOS Management Guide").
	BLINK	Location indicator ("Here I am!"). Activated when connected to IPConfig Tool, or upon request from Web or CLI.
DC1	OFF	Unit has no power.
	GREEN	Power OK on DC1.
	RED	Power failure on +DC1.
DC2	OFF	Unit has no power.
	GREEN	Power OK on DC2.
	RED	Power failure on +DC2.
FRNT	OFF	FRNT disabled.
	GREEN	FRNT OK.
	RED	FRNT Error.
	BLINK	Unit configured as FRNT Focal Point.
RSTP	OFF	RSTP disabled.
	GREEN	RSTP enabled.
	BLINK	Unit elected as RSTP/STP root switch.
VPN	OFF	VPN disabled.
	GREEN	(Configurable) Default: At least one VPN tunnel up and OK.
	RED	(Configurable) Default: All VPN tunnels down.
Copper ports Port 1-4	OFF	No Link.
	GREEN	Link established.
	GREEN FLASH	Data traffic indication.
	YELLOW	Port alarm and no link. Or if FRNT or RSTP mode, port is blocked.
DSL ports Port 1-2	OFF	No SHDSL link.
	GREEN	SHDSL link established.
	GREEN BLINK	SHDSL link negotiation.
	GREEN FLASH	Data traffic indication.
	YELLOW	Port alarm and no link. Or if FRNT or RSTP mode, port is blocked.
	YELLOW BLINK	Only during unit startup. Firmware downloading to SHDSL chip.
Serial port, RS-232 (DCE mode)		
TD	OFF	No serial data received
	GREEN FLASH	Serial data received
RD	OFF	No serial data transmitted
	GREEN FLASH	Serial data transmitted

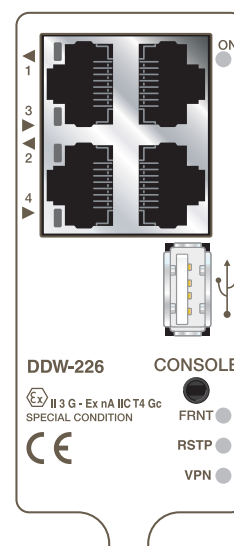
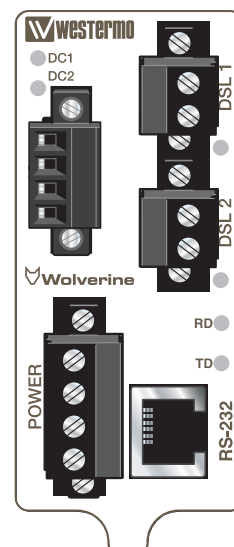

Mounting

Mounting, 35 mm DIN-rail

The unit can be mounted on a 35 mm DIN-rail, which is horizontally mounted inside an apparatus cabinet, or similar. Snap on mounting, see figure.

Note! For proper vibration and chock performance Westermo recommends standard top-hat DIN-rail TH 35-15 according to EN 60715.

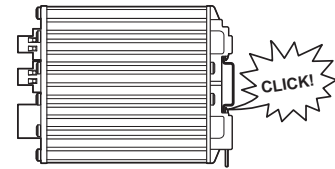
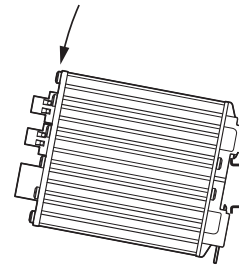

Removal

Press down the support at the back of the unit using a screwdriver. See figure.

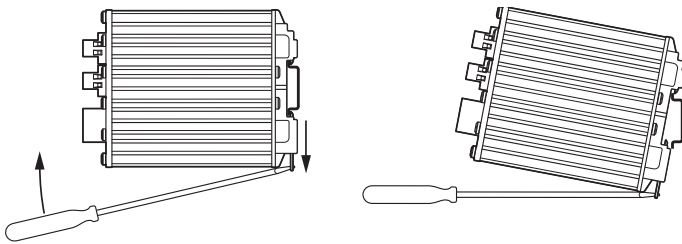

Wall mounting

This unit can also be wall-mounted, see figure.

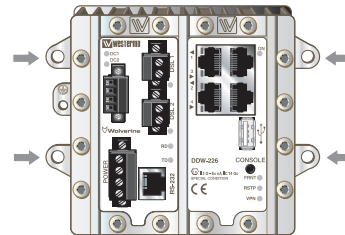

Earth connection

For correct function the ground connection on the unit needs to be properly connected to a solid ground. See figure.

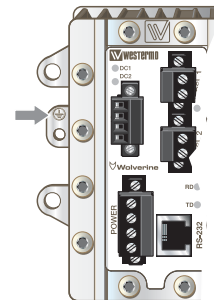

Cooling

This unit uses convection cooling. To avoid obstructing the airflow around the unit, use the following spacing rules. Minimum spacing 25 mm (1.0 inch) above /below and 10 mm (0.4 inches) left /right the unit.

Spacing is recommended for the use of unit in full operating temperature range and service life. See figure.

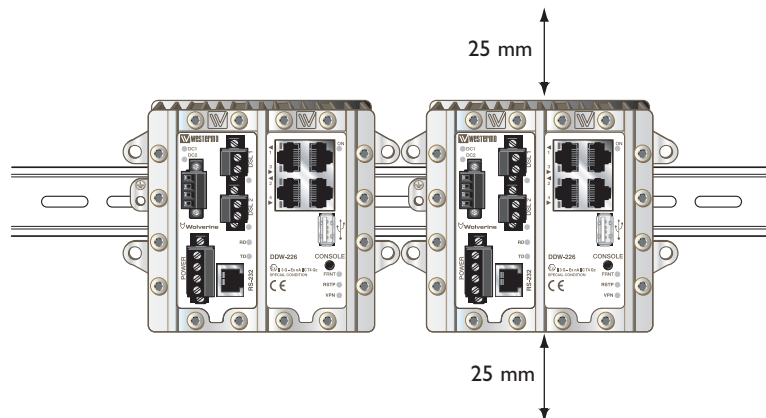

Getting Started

This product runs Westermo Operating System (WeOS) which provides several management tools that can be used for configuration of the unit.

- **IPConfig tool**

This is a custom Westermo tool used for discovery of attached Westermo units.

- **Web**

Configuration of the unit using the web browser.

- **CLI**

Configuration of the unit via the Command Line Interface.

If the computer is located in the same subnet as the switch you can easily use a web browser to configure the unit. Within the web you can configure most of the available functions.

For advanced network settings and more diagnostic information, please use the CLI. Detailed documentation is available in the chapter "The Command Line Management Tool" in the WeOS management guide.

Factory default	IP address:	192.168.2.200
	Netmask:	255.255.255.0
	Gateway:	Disabled

Note! If you are not sure about the subnet – consult your network administrator.

Configuration

Configure the unit via Webbrowser

The unit can easily be configured via a Web browser.

Open the link <http://192.168.2.200> in your web browser, and you will be prompted with a Login screen, where the default settings for Username and Password are:

Username: admin

Password: westermo

Once you have logged in, you can use the extensive integrated help function describing all configuration options. Two common task when configuring a new switch is to assign appropriate IP settings, and to change the password of the admin account.

The password can be up to 64 characters long, and should consist of printable ASCII characters (ASCII 33-126); 'Space' is not a valid password character.

Note! Version of IP Config tool must be 10.3.0 or higher.

Referring documents

Type	Description	Document number
Management Guide	Westermo OS management guide	6101-3201

Factory default on DDW-226

It is possible to set the unit to factory default settings by using two standard Ethernet RJ-45 cables.

1. Power off the switch and disconnect all Ethernet cables and DSL cables.
 2. Connect one Ethernet cable between Ethernet port 1 and Ethernet port 4, and another Ethernet cable between Ethernet port 2 and Ethernet port 3.
The ports need to be connected directly by Ethernet cables, i.e., not via a hub or switch. Use straight cables – not cross-over cables – when connecting the port pairs.
 3. Power on the unit.
 4. Wait for the unit to start up. Control that the ON LED is flashing red.
The ON LED flashing indicates that the unit is now ready to be reset to factory default. You now have the choice to go ahead with the factory reset, or to skip factory reset and boot as normal.
 - Go ahead with factory reset:
Acknowledge that you wish to conduct the factory reset by unplugging one of the Ethernet cables. The ON LED will stop flashing.
This initiates the factory reset process*, and after approximately 1 minute the unit will restart with factory default settings. When the switch has booted up, the ON LED will typically show a green light (a red light is shown if only one of the DC power feeds is connected).
 - Skip the factory reset:
To skip the factory reset process, just wait for approximately 30 seconds (after the ON LED starts flashing RED) without unplugging any of the Ethernet cables. The switch will conduct a normal boot with the existing settings.
- * **Note** Do not power off the unit while the factory reset process is in progress.



Westermo Teleindustri AB • SE-640 40 Stora Sundby, Sweden
Phone +46 16 42 80 00 Fax +46 16 42 80 01
E-mail: info@westermo.se
Westermo Web site: www.westermo.com

Subsidiaries

Westermo Data Communications AB
Svalgången 1
SE-724 81 Västerås
Phone: +46 (0)21 548 08 00 • Fax: +46 (0)21 35 18 50
info.sverige@westermo.se

Westermo Data Communications Ltd
Talisman Business Centre • Duncan Road
Park Gate, Southampton • SO31 7GA
Phone: +44(0)1489 580-585 • Fax: +44(0)1489 580586
E-Mail: sales@westermo.co.uk

Westermo Data Communications GmbH
Goethestraße 67, 68753 Waghäusel
Tel.: +49(0)7254-95400-0 • Fax: +49(0)7254-95400-9
E-Mail: info@westermo.de

Westermo Data Communications S.A.R.L.
9 Chemin de Chilly 91160 CHAMPLAN
Tél : +33 1 69 10 21 00 • Fax : +33 1 69 10 21 01
E-mail : infos@westermo.fr

Westermo Data Communications Pte Ltd
2 Soon Wing Road #08-05
Soon Wing Industrial Building
Singapore 347893
Phone +65 6743 9801 • Fax +65 6745 0670
E-Mail: sales@westermo.com.sg

Westermo Teleindustri AB have distributors in several countries, contact us for further information.