

# VARISPEED-616G5 OPTION CARD DIGITAL REFERENCE CARD DI-16H2 INSTRUCTIONS

---

Upon receipt of the product and prior to initial operation, read these instructions thoroughly, and retain for future reference.

---



YASKAWA

MANUAL NO. TOE-C736-40.7B

AUDIN - 7 bis rue de Tinquaux - 51100 Reims - France

Tel : 03.26.04.20.21 - Fax : 03.26.04.28.20 - Web : [http: www.audin.fr](http://www.audin.fr) - Email : [info@audin.fr](mailto:info@audin.fr)

## NOTES FOR SAFE OPERATION

Read this instruction manual thoroughly before installation, operation, maintenance or inspection. In this manual, the NOTES FOR SAFE OPERATION is classified as “CAUTION”.



Indicates a potentially hazardous situation which, if not avoided, may result in minor or moderate injury to personnel and damage to equipment.

It may also be used to alert against unsafe practices.

Even items described in  may result in a vital accident in some situations. In either case, follow these important items.

 : These are steps to be taken to insure proper operation and to avoid malfunctions, etc.

### CAUTION

- The option card uses C MOS IC chips. It may break if touched by bare fingers because of static electricity. Be careful when handling.
- When removing the option card from the inverter for transportation or storage, put the card into the anti-static package it was in when delivered.
- Never change wiring or connect or disconnect connectors while the power is ON.

Failure to observe this caution may injure you.

The digital reference card, DI-16H2 is mounted on the control board of the inverter to set up digital speed references. To set up references using DI-16H2, set the b1-01 operation mode selection constant to 3 (option). For the values of other constants, refer to ‘descriptive manual for constants’ (manual No. TOEZ-S616-10.11).

This option card is applicable to the following inverter series:  
VS-616G5: Entire series

Name	Code No.	Functions
Digital reference card DI-16H2	73600-C016X	Input signal: Binary 16 bits/BCD 4 digits Binary 12 bits/BCD 3 digits    Switch by S1  SIGN and SET signal input voltage: +24V (Power supply built in. Electrically isolated from internal circuit)

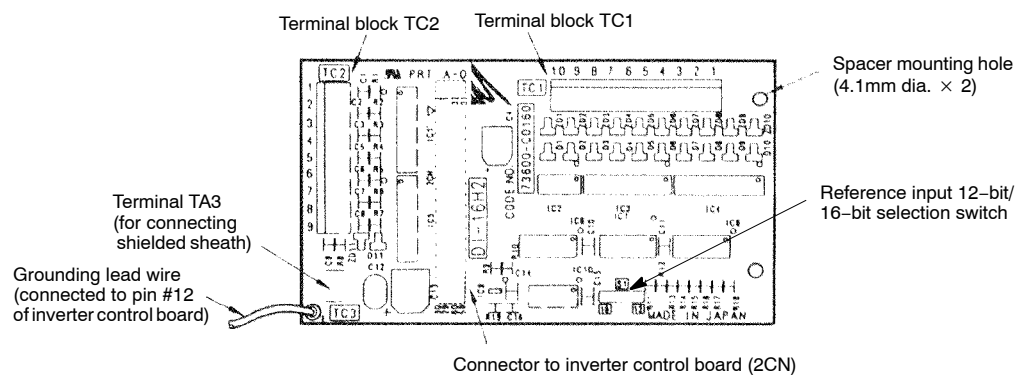

Fig. 1 Digital reference card DI-16H2

**NOTE**

Before use,

- (1) Before using DI-16H2, read this manual and the manual for the installation of the inverter.
- (2) Before connecting DI-16H2 or external terminals, turn OFF main power of the inverter and verify the CHARGE indicator lamp of the inverter is OFF.
- (3) When ordering DI-16H2, specify the name and code number.

---

# 1 Inspection after Delivery



## CAUTION

- Verify that ordered products have been delivered.  
Installation of a wrong device may lead to injury or damage.

Though the products have undergone rigorous inspection before shipping, check the following for safety.

- Check the name written on the product to verify that ordered products have been delivered.
- Check for damage caused during transportation.

If there is anything uncertain on the structure, contact your YASKAWA representative.

## 2 Installing to Inverter (See Fig. 2)

### 2.1 Installation Procedure

- ① Turn OFF the main power and wait for the time specified on the cover of the inverter. Remove the cover and verify that the CHARGE indicator lamp is OFF.
- ② Plug the 2CN connector of the digital reference card DI-16H2 into the 2CN connector (60 pins) on the control board of the inverter. Gently push DI-16H2 until the spacer engages the spacer hole of the option card on the control board. Fix DI-16H2 tightly. (See part A of the side view.)
- ③ After installing DI-16H2, connect the inverter with peripheral devices and replace the cover of the inverter.

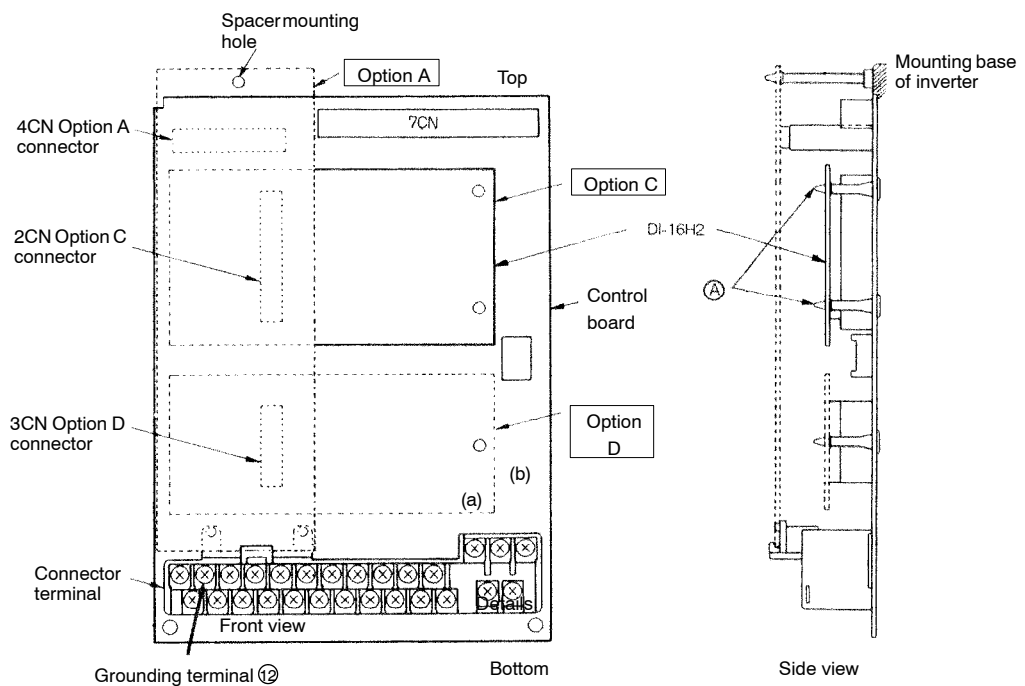
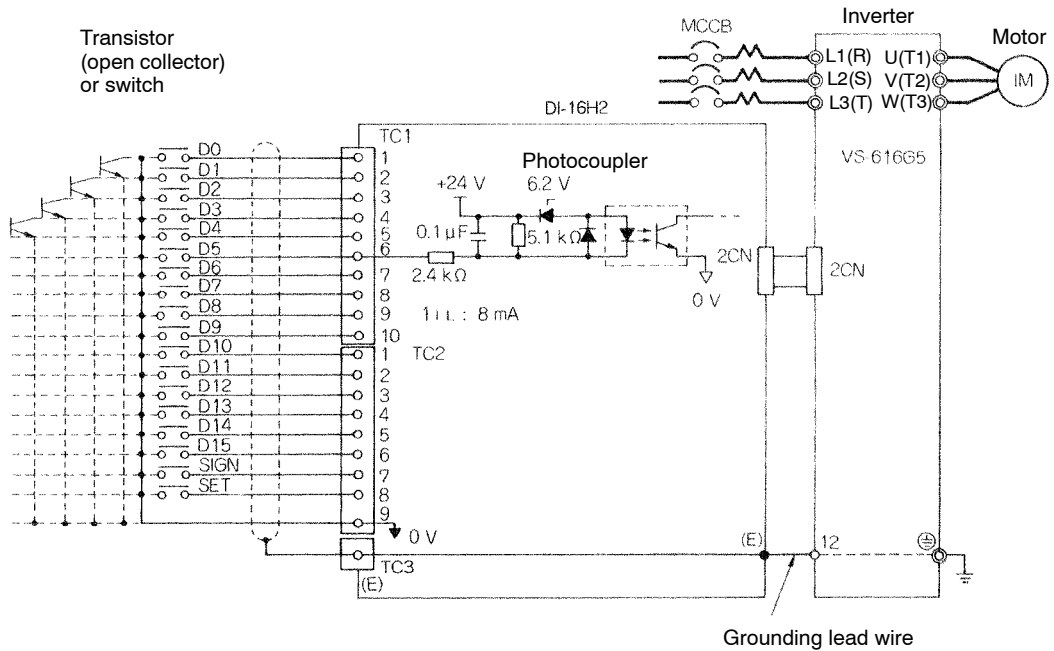

Fig. 2 Installation of digital reference card DI-16H2

### 3 Interconnection

Fig. 3 shows interconnection between the inverter, DI-16H2, and peripheral equipment.



- Note:
- Connect the grounding lead wire with the control terminal ⑫ on the control board of the inverter.
  - All the input circuits, TC1-1 to -10 and TC2-1 to -9 are identical. (The TC1-6 input circuit is represented in the diagram.)

Fig. 3 Interconnection diagram

NOTE

Notes on wiring

- Separate the control signal wires ( from terminals TC1, TC2, and TC3 ) of the DI-16H2 from the main circuit wires and other power cables.
- Use a shielded wire to connect to TC1 and TC2. Connect the wire as shown in Fig. 4 to prevent interference by noise. The wire must be 50m or shorter.

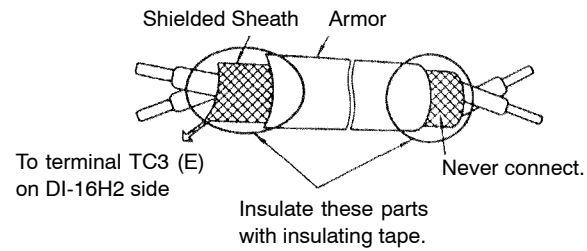

Fig. 4 Shielded wire termination

## 4 Wiring

See Table 1 for the functions of the input terminals. The functions can be selected by combination of constant F3-01 setting (frequency reference setting selection) and switch S1 (reference input 12-bit/16-bit selection).

Table 1 Digital reference input terminal functions

Terminal block symbol	Pin No.	Input signal type *							
		With SIGN 12-bit binary	Without SIGN 16-bit binary	With SIGN BCD 3 digits	With SIGN BCD 4 digits	Without SIGN BCD 5 digits			
		F3-01: 7 S1: 12 bits	F3-01: 7 S1: 16 bits	F3-01: 0 to 5 S1: 12 bits	F3-01: 0 to 5 S1: 16 bits	F3-01: 6 S1: 16 bits			
TC1	1	Bit 1 (2 <sup>0</sup> )	Bit 1 (2 <sup>0</sup> )	1	BCD 1 digit (0 to 9)	1	BCD 1 digit (0 to 9)	2	BCD 1 digit (0, 2, 4, 6, 8)
	2	Bit 2 (2 <sup>1</sup> )	Bit 2 (2 <sup>1</sup> )	2		2		4	
	3	Bit 3 (2 <sup>2</sup> )	Bit 3 (2 <sup>2</sup> )	4		4		8	
	4	Bit 4 (2 <sup>3</sup> )	Bit 4 (2 <sup>3</sup> )	8	8	1	BCD 2 digits (0 to 9)		
	5	Bit 5 (2 <sup>4</sup> )	Bit 5 (2 <sup>4</sup> )	1	1	2			
	6	Bit 6 (2 <sup>5</sup> )	Bit 6 (2 <sup>5</sup> )	2	2	4			
	7	Bit 7 (2 <sup>6</sup> )	Bit 7 (2 <sup>6</sup> )	4	4	8	BCD 3 digits (0 to 9)		
	8	Bit 8 (2 <sup>7</sup> )	Bit 8 (2 <sup>7</sup> )	8	8	1			
	9	Bit 9 (2 <sup>8</sup> )	Bit 9 (2 <sup>8</sup> )	1	1	2			
	10	Bit 10 (2 <sup>9</sup> )	Bit 10 (2 <sup>9</sup> )	2	BCD 3 digits † (0 to 15)	2	BCD 3 digits (0 to 9)	4	BCD 4 digits (0 to 9)
1	Bit 11 (2 <sup>10</sup> )	Bit 11 (2 <sup>10</sup> )	4	4	4	8			
2	Bit 12 (2 <sup>11</sup> )	Bit 12 (2 <sup>11</sup> )	8	8	1	BCD 5 digits (0 to 3)			
3	—	Bit 13 (2 <sup>12</sup> )	—	—	1		BCD 4 digits (0 to 15)		
4	—	Bit 14 (2 <sup>13</sup> )	—	—	2				
5	—	Bit 15 (2 <sup>14</sup> )	—	—	4				
6	—	Bit 16 (2 <sup>15</sup> )	—	—	8	8			
7	SIGN signal (0: forward, 1: reverse)							2	
8	SET (read) signal (1: read) ‡								
9	Input signal common (0V)								
TC3	Shielded connection terminal								

\* At the digital reference, internal signal reads “0” when input signal is open, and reads “1” when input signal is closed (between the signal and common terminal). Selection switch S1 is used for 12-bit/16-bit selection of input signal.

† The first digit can be set between 0 and 15 at BCD input.

‡ Set (read) signal is the signal to read digital reference data. When reading, close between terminals TC2-8 and TC2-9 by the timing shown in Fig. 5



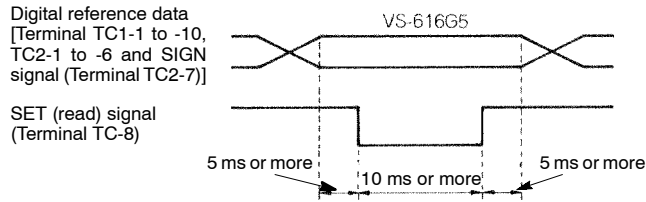

Fig. 5 Timing of digital reference read signal

Make sure the followings when wiring.

- To prevent noise, use shielded wire and separate from heavy current circuits (200VAC or greater) or relay drive circuits. (Wire length must be 50m or shorter.)
- Connect both ends of the unused wire of the shielded wire to the 0V terminal.
- Connect the grounding lead wire (E) to pin ② of the control board of the inverter.
- Applicable wire sizes for terminal block TC1 and TC2 are shown below.  
[Terminal: MKDS1 series manufactured by Phoenix Contact GmbH & Co.]

	[mm <sup>2</sup> ]	AWG	I [A]	VAC [V]
Thin twisted wire	1	16	12	125
Solid wire	1.5	16	12	125
UL	—	22-16	10	300
CSA	—	28-16	10	300
CSA	—	28-16	10	150



Terminal block TC1, TC2 side  
Connecting wire end

NOTE

#### Notes on selecting cables

Too thick a cable applies pressure to the option card and may lead to failure.  
Too thin a cable may lead to imperfect contact or a break in the wire.

---

## 5 Notes on Use of Input Signals

The input circuit of DI-16H2 receives outputs from relay contacts or (open collector) transistors. Note the points below:

- When using relay contacts for digital instruction signals, select highly reliable relay contacts (for weak current) of a contact capacity of 30VDC or greater and 100mA or lower.
- When using (open collector) transistors, select ones of a dielectric strength of 35VDC or greater, rated current of 30mA or greater.

## 6 Digital Reference Selection

For digital reference with this option card, set constant b1-01 (frequency reference selection) to “3” (DI-16H2 side).

Table 2 Digital reference selection

Constant setting		Switch S1 selection	Reference input mode	Reference setting range*	Monitor (U1-01) display unit	
o1-03	F3-01				o1-03=0	o1-03=1
0 or 1	0	12 bits	With SIGN BCD 3 digits, 1%	-110 to +110%	0.01 Hz	0.01%
		16 bits	With SIGN BCD 4 digits, 1%			
	1	12 bits	With SIGN BCD 3 digits, 0.1%	-110.0 to +110.0%		
		16 bits	With SIGN BCD 4 digits, 0.1%			
	2	12 bits	With SIGN BCD 3 digits, 0.01%	-15.99 to +15.99%		
		16 bits	With SIGN BCD 4 digits, 0.01%	-110.00 to +110.00%		
	3	12 bits	With SIGN BCD 3 digits, 1 Hz	-400 to +400 Hz		
		16 bits	With SIGN BCD 4 digits, 1 Hz			
	4	12 bits	With SIGN BCD 3 digits, 0.1 Hz	-159.9 to +159.9 Hz		
		16 bits	With SIGN BCD 4 digits, 0.1 Hz	-400.0 to +400.0 Hz		
	5	12 bits	With SIGN BCD 3 digits, 0.01 Hz	-15.99 to +15.99 Hz		
		16 bits	With SIGN BCD 4 digits, 0.01 Hz	-159.99 to +159.99 Hz		
	6	16 bits	Without SIGN BCD 5 digits, 0.01 Hz	000.00 to +399.98 Hz		
	7	12 bits	With SIGN 12-bit binary, 100%/4095	-4095 to +4095		
16 bits		With SIGN 16-bit binary, 100%/30000	-33000 to +33000			
2 to 39 †	—	12 bits	With SIGN BCD 3 digits, 1 r/min	-1599 to +1599 r/min	1 r/min	
		16 bits	With SIGN BCD 4 digits, 1 r/min	-15999 to +15999 r/min	1 r/min	
40 to x9999 ‡ (x=0 to 3)	—	12 bits	With SIGN BCD 3 digits, 100%/1st to 4th digit of o1-03 setting	-1599 to +1599	5th digit of o1-03 setting x=0: unit: 1 x=1: unit: 0.1 x=2: unit: 0.01 x=3: unit: 0.001	
		16 bits	With SIGN BCD 4 digits, 100%/1st to 4th digit of o1-03 setting	-10999 to +10999 (when o1-03=9999)		
x0000 (x=1 to 3)	—	16 bits	With SIGN BCD 4 digits, 100%/10000	-11000 to +11000		

- \* • Value when max. output frequency (E1-04) is 400 Hz and frequency reference upper limit (d2-01) is 110%.
- Setting range upper limit  $\leq$  max. output frequency (E1-04) or frequency reference upper limit (d2-01)  
Setting range lower limit  $\geq$  min. output frequency (E1-09) or frequency reference lower limit (d2-02)
- The first digit can be set between 0 and 15 at BCD input.
- † • Set number of motor poles in o1-03 (setting/display unit of frequency reference/monitor).  
• Output frequency (F) = reference set value (r/min)  $\times$  (o1-03 setting) / 120
- ‡ Setting example for o1-03:  
When o1-03=12000, reference input at 100% is 2000 and monitor display becomes 200.0.

For setting and selecting constants, refer to the constants list in ‘descriptive manual for constants’ (Manual No. TOEZ-S616-10.11).