

Varispeed SERIES INVERTER OPTION CARD  
ANALOG MONITOR CARD  
**INSTRUCTIONS**

MODEL AO-12

---

Upon receipt of the product and prior to initial operation, read these instructions thoroughly, and retain for future reference.

---



YASKAWA

MANUAL NO. TOE-C736-30.22D

The analog monitor card (AO-12), an on-board type option card, is mounted on the inverter control board to output analog signals for monitoring the inverter outputs (output frequency, output current, etc.).

This AO-12 is applicable to the following five inverter series :

- VS-616G3      • VS-616H3      • VS-676VG3
- VS-676VH3    • VS-616G5

Name	Code No.	Applicable Inverter Series	Output Method
Analog Output Monitor Card AO-12	73600-D002X	VS-616G3 VS-616H3	Output resolution : 11 bits (1/2048) Output voltage : 0 to +10 V (non-insulated) Output channel : 2 channels
		VS-616G5 VS-676VG3 VS-676VH3	Output resolution : 11 bits + SIGN (1/2048) Output voltage : -10 to +10 V (non-insulated) Output channel : 2 channels

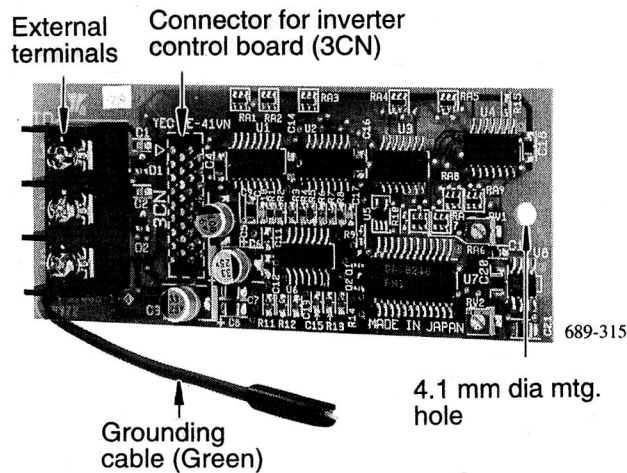

ANALOG MONITOR CARD AO-12

## PRECAUTIONS

- (1) Before using AO-12, read the instruction manual of the applicable inverters.
- (2) Before connection of AO-12 connector or external terminals, turn off the inverter AC main circuit power supply and check that inverter CHARGE indicator lamp is out.
- (3) When ordering AO-12, specify the product name and the code No.

## 1 INSTALLATION TO INVERTER

- (1) Turn off AC main circuit power supply and remove the inverter face plate. Check that the inverter CHARGE indicator lamp is out.
- (2) Mount AO-12 connector 3CN on connector 3CN (number of pins : 34 poles) on the inverter control board. Insert the optional card support on the control board to AO-12 support hole (1 point) to support the AO-12.

### NOTE

AO-12 cannot be mounted on any connectors other than 3CN.

- (3) Connect AO-12 grounding cable (green) to control terminal No. 12 on the inverter control board.
- (4) After installing the AO-12, connect to peripheral equipment. When connection is completed, replace the inverter face plate.

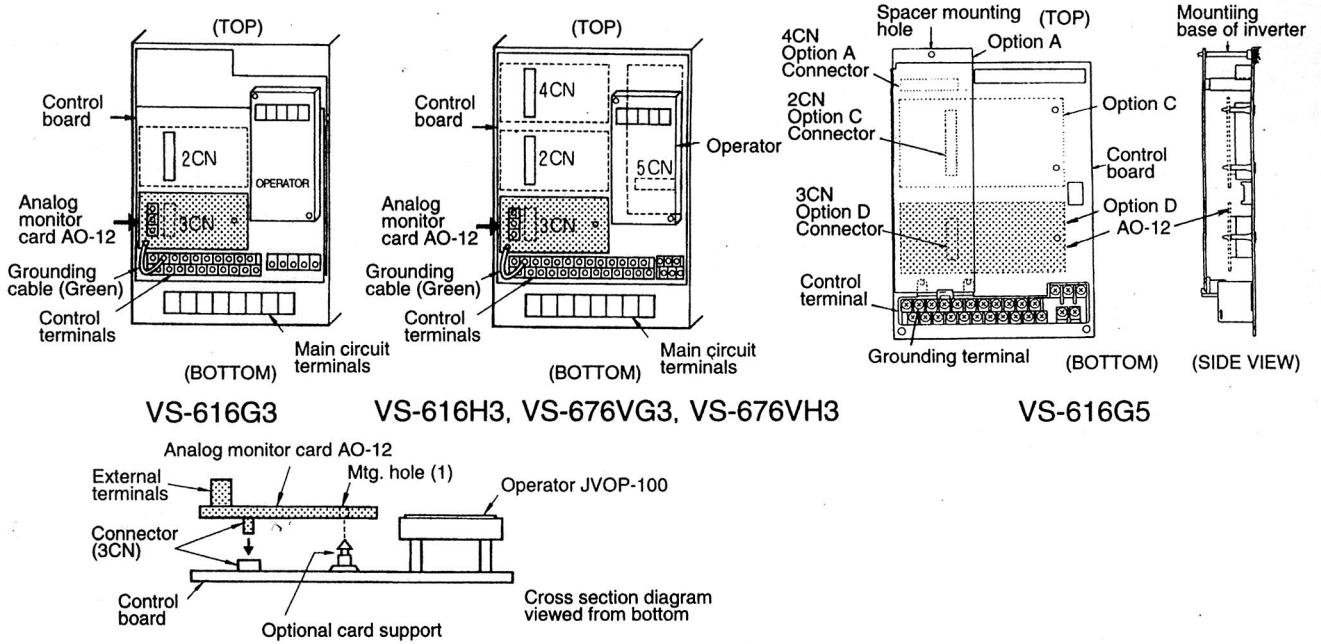
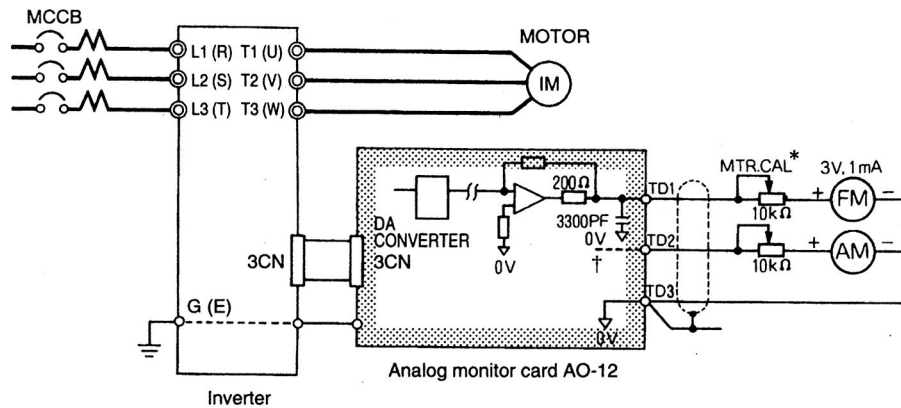

Fig. 1 Installation of Analog Monitor Card AO-12

## 2 INTERCONNECTION BETWEEN EQUIPMENT

Fig. 2 shows interconnection of inverter with AO-12 and peripheral equipment where AO-12 output is connected to a pulse counter.



\* In some applications, MTR.CAL can be omitted by setting or adjusting program constants (bn- [ ] [ ]).

† TD2 output circuit is the same as that of TD1.

Fig. 2 Interconnection Diagram

### NOTES ON WIRING

- (1) Separate AO-12 control signal wiring (terminals TD1 to TD3) from main circuit wiring or other power lines.
- (2) Use shielded cable for control signal wiring and prepare the ends as shown in Fig. 3 to prevent malfunctions caused by noise. Wiring length must be 50 m or less.

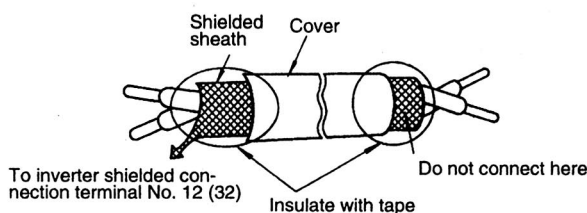

Fig. 3 Shielded Wire Termination

### 3 EXTERNAL TERMINAL FUNCTIONS

AO-12 has 3 external terminals for connection with peripheral equipment. Table 1 shows the terminal functions.

Table 1 Terminal Functions

Terminal Symbol	Screw Size	Function	Signal Level	Output Accuracy	Remarks
TD1	M3	Analog signal output : channel 1 *	-10 to +10 V (max. load current : 3 mA) <sup>†</sup>	Refer to Tables 2 to 4.	Output resolution : 11 bits + SIGN (1/2048)
TD2		Analog signal output : channel 2 *			
TD3		Common terminal	0V		

\* Output contents of TD1 or TD2 analog signal can be selected by setting the inverter program constants. For details, refer to "EXTERNAL TERMINAL OUTPUT CONTENTS AND ACCURACY."

† • Output signal level of TD1 or TD2 analog signal can be adjusted by setting the inverter program constants. For details, refer to "OUTPUT SIGNAL LEVEL SETTING."

- When AO-12 is mounted on VS-616G3 or VS-616H3, output signal level varies 0 to +10 V. In this case, negative polarity (0 to -10) cannot be output.
- Output signal level can be output up to 11 V by setting program constants.

### 4 EXTERNAL TERMINAL OUTPUT CONTENTS AND ACCURACY

Table 2 Connection with VS-616G3

External Terminal	Program Constant No.	Set Value	Output Contents	Output Accuracy
TD1 Channel 1	Sn-28 1st/2nd digit	00	Output frequency : Max. frequency/100%	1.0%
		01	Output current : Inverter rated current/100%	3.0%
TD2 Channel 2	Sn-28 3rd/4th digit	10	Output voltage ref. : Input voltage/100%	1.5%
		11	DC voltage (V <sub>PN</sub> ) : 400 V/100% (200 V class) 800 V/100% (400 V class)	1.5%

Table 3 Connection with VS-616H3

External Terminal	Program Constant No.	Set Value	Output Contents	Output Accuracy
TD1 Channel 1	bn-15	1	Frequency ref. : Max. frequency/100%	1.0%
		2	Output frequency : Max. frequency/100%	
		3	Output current : Rated current/100%	3.0%
		4	Output voltage ref. : Input voltage/100%	1.5%
5	DC voltage (V <sub>PN</sub> ) : 400 V/100% (200 V class) 800 V/100% (400 V class)			
TD2 Channel 2	bn-17	6	Output power (± indication) : Rated power (kW)/100%	10.0%
		17	Speed feedback (PG, TG) : Max. frequency/100%	
		18	Compensated frequency (PG, TG) : Max. frequency/100%	1.0%
		19	Voltage feedback (AVR) : Input voltage/100%	
		20	Compensated voltage (AVR) : Input voltage/100%	
		21	Momentary reduced value : Max. frequency/100%	

Note : Refer to "OUTPUT SIGNAL LEVEL SETTING" for 100% output signal level in output contents.

Table 4 Connection with VS-676VG3 or VS-676VH3

External Terminal	Program Constant No.	Set Value	Output Contents	Output Accuracy
TD1 Channel 1	bn-22	3	Output current : Motor rated current/100%	3.0%
		4	Output voltage ref. : No-load voltage/100%	1.5%
		5	DC voltage (V <sub>PN</sub> ) : 400 V/100% (200 V class), 800 V/100% (400 V class)	
		21	Speed ref. (SFS input) : Max. rotation speed/100%	1.0%
		22	Speed ref. (SFS output) : Max. rotation speed/100%	
		23	Speed feedback : Max. rotation speed/100%	
		24	Ext. torque ref. : Motor rated torque/100%	
		25	Torque compensation : Motor rated torque/100%	
		26	Torque ref. (inner) : Motor rated torque/100%	
		27	Torque feedback : Motor rated torque/100%	
28	ASR input (speed deviation) : Max. rotation speed/100%			
29	ASR output (after filter) : Motor rated secondary current/100%			
30	Slip frequency : Rated slip frequency/100%			
TD2 Channel 2	bn-24	31	Primary frequency ref. : Max. synchronous frequency/100%	
		32	Motor temp : 200 °C/100%	



Note : Refer to "OUTPUT SIGNAL LEVEL SETTING" for 100% output signal level in output contents.

Table 5 Connection with VS-616G5

Constant No.	Name	Change during Operation	Setting Range	Initial Value
F4-01	TD1 (Channel 1) monitor selection	Disabled	1 to 27 (Refer to Table 6.)	2
F4-03	TD2 (Channel 2) monitor selection	Disabled	1 to 27 (Refer to Table 6.)	3

Table 6 Set Values when Connected to VS-616G5

Set Value	Output Contents	Output Accuracy
1	Frequency reference Display unit can set by constant o1-03	10 V : Max. frequency (Corresponds to -10 to +10 V)*
2	Output frequency Display unit can be set by constant o1-03	10 V : Max. frequency (Corresponds to -10 to +10 V)*
3	Output current	10 V : Inverter rated output current (0 to +10 V absolute valute output)
5	Detected motor speed	10 V : Max. frequency (Corresponds to -10 to +10 V)*
6	Inverter's internal output voltage reference	10 V : 200 VAC (400 VAC) (0 to +10 V output)
7	Inverter's internal main circuit DC voltage	10 V : 400 VAC (800 VAC) (0 to +10 V output)
8	Output power (Internally detected value)	10 V : Inverter capacity (Max. applicable motor output) (Corresponds to -10 to +10 V)*
9	Internal torque reference during vector control	10 V : Motor rated torque (Corresponds to -10 to +10 V)*
15	Frequency reference input voltage Displays 100% during 10 V input	10 V : 100% (at 10 V input) (Corresponds to -10 to +10 V)*
16	Frequency reference input current Displays 100% during 20 mA input	10 V : 100% (at 20 mA input) (Corresponds to -10 to +10 V)*
17	Input voltage of multi-function analog input Displays 100% during 10 V input	10 V : 100% (at 10 V input) (Corresponds to -10 to +10 V)*
18	Motor secondary current operation value Displays 100% at motor rated current	10 V : Motor rated current (0 to +10 V output)
19	Motor exciting current operation value Diaplays 100% at motor rated current	10 V : Motor rated current (0 to +10 V output)
20	Output frequency after soft-start Displays frequency without the compensation (e.g. slip compensation)	10 V : Max. frequency (Corresponds to -10 to +10 V)*
21	Input to speed control loop Displays 100% at max. frequency	10 V : Max. frequency (Corresponds to -10 to +10 V)*
22	Output from speed control loop Displays 100% motor rated current	10 V : Motor rated current (Corresponds to -10 to +10 V)*
23	Speed deviation in speed control loop	10 V : Max. frequency (Corresponds to -10 to +10 V)*
24	PID feedback value 100% at input corresponding to max. frequency	10 V : Max. frequency (Corresponds to -10 to +10 V)*
26	Internal voltage reference toward motor secondary current control	10 V : 200 VAC (400 VAC) (Corresponds to -10 to +10 V)*
27	Internal voltage reference toward motor exciting current control	10 V : 400 VAC (800 VAC) (Corresponds to -10 to +10 V)*

\*Set constant H4-07 to 1 when setting -10 to +10 V output.

## 5 OUTPUT SIGNAL LEVEL SETTING

Output signal level of external terminal TD1 or TD2 can be set by  $10 \text{ V} \times \square\square\square\square$  (setting data)/100%.

Applicable Inverter	External Terminal	Program Constant No.	Setting Range	Setting Unit	Initial Value
VS-616G3	TD1	bn-11	0.00 to 2.55	0.01	1.00
	TD2	bn-12			0.50
VS-616H3	TD1	bn-16	0.000 to 10.000	0.001	1.000
	TD2	bn-18			0.500
VS-676VG3 VS-676VH3	TD1	bn-23	0.000 to 10.000	0.001	1.000
	TD2	bn-25			
VS-616G5	TD1	F4-02	0.00 to 2.55	0.01	1.00
	TD2	F4-04			0.50