

# **F400 Color Vision Sensor**

## **SETUP MANUAL**

**OMRON**

# **F400 Color Vision Sensor**



## **Setup Manual**



*Produced May 1999*

## Notice:

OMRON products are manufactured for use according to proper procedures by a qualified operator and only for the purposes described in this manual.

The following conventions are used to indicate and classify precautions in this manual. Always heed the information provided with them. Failure to heed precautions can result in injury to people or damage to property.

-  **DANGER** Indicates an imminently hazardous situation which, if not avoided, will result in death or serious injury.
-  **WARNING** Indicates a potentially hazardous situation which, if not avoided, could result in death or serious injury.
-  **Caution** Indicates a potentially hazardous situation which, if not avoided, may result in minor or moderate injury, or property damage.

	<b>Electric Shock</b> Indicates particular circumstances which, if not avoided, could result in electric shock.
	<b>High Temperatures</b> Indicates particular circumstances which, if not avoided, could result in heat burns.

## Visual Aids

The following headings will help you locate different types of information.

**Note** Indicates information of particular interest for efficient and convenient operation of the product.

→ Indicates pages where additional information can be found.

**1, 2, 3...** 1. Indicates a procedure. The step numbers in the procedure correspond to the numbers in any related illustrations.

## Trademark

The F400 was developed in cooperation with KURABO INDUSTRIES LTD. KURABO is a registered trademark of KURABO INDUSTRIES LTD.

© OMRON, 1999

All rights reserved. No part of this publication may be reproduced, stored in a retrieval system, or transmitted, in any form, or by any means, mechanical, electronic, photocopying, recording, or otherwise, without the prior written permission of OMRON.

No patent liability is assumed with respect to the use of the information contained herein. Moreover, because OMRON is constantly striving to improve its high-quality products, the information contained in this manual is subject to change without notice. Every precaution has been taken in the preparation of this manual. Nevertheless, OMRON assumes no responsibility for errors or omissions. Neither is any liability assumed for damages resulting from the use of the information contained in this publication.

# TABLE OF CONTENTS

<b>PRECAUTIONS</b> .....	<b>xi</b>
1 Safety Precautions .....	xii
2 General Precautions .....	xii
3 Export Precautions .....	xiii
<b>SECTION 1</b>	
<b>Before Installing</b> .....	<b>1</b>
1-1 Installation Precautions .....	2
1-2 Confirming Package Contents .....	3
1-3 Product Availability .....	4
<b>SECTION 2</b>	
<b>Product Introduction</b> .....	<b>5</b>
2-1 Component Names and Functions .....	6
2-2 Connections .....	7
2-3 Power Supply and Ground .....	7
2-4 Camera .....	9
2-5 CCTV Lens .....	9
2-6 Lighting .....	11
2-7 Mounting the Controller .....	13
<b>SECTION 3</b>	
<b>Terminal Blocks</b> .....	<b>15</b>
3-1 Crimp Terminals and Cables .....	16
3-2 Specifications .....	16
3-3 Terminals .....	17
<b>SECTION 4</b>	
<b>RS-232C Connection</b> .....	<b>19</b>
4-1 Connector .....	20
4-2 Wiring .....	20
4-3 Connection .....	21
<b>SECTION 5</b>	
<b>Troubleshooting</b> .....	<b>23</b>
5-1 Connection Errors .....	24
5-2 Errors during Menu Operation .....	24
5-3 Terminal Block Errors .....	24
5-4 RS-232C Communications Errors .....	24
<b>SECTION 6</b>	
<b>Inspection</b> .....	<b>25</b>
6-1 Regular Inspections .....	26
<b>SECTION 7</b>	
<b>Specifications</b> .....	<b>27</b>
7-1 F400 Vision Mate Controller .....	28
7-2 K150-KP Console .....	29
7-3 Camera .....	30
7-4 Cables .....	31
<b>Revision History</b> .....	<b>33</b>

## About this Manual:

This manual describes the hardware for the F400 Color Vision Sensor and how to install the components, and it includes the sections described below. This is one of three manuals used to operate the F400. Refer to the following table for the contents of each manual.

Manual	Contents	Cat. No.
<b>1: Introduction Manual</b>	Describes F400 capabilities and basic operating procedures for beginners by using typical applications.	Z131-E1-1
<b>2: Setup Manual</b>	Provides information on system hardware and installation.	Z130-E1-1
<b>3: Operation Manual</b>	Describes operation of the F400, including setting of criteria, communication with external devices, etc.	Z135-E1-1

Please read the above manuals carefully and be sure you understand the information provided before attempting to install or operate the F400.

**Section 1 Before Installing** describes the precautions that must be taken when installing and operating the F400 Color Vision Sensor.

**Section 2 Product Introduction** describes the wiring, Camera, optical lenses, lighting modes, and light guides used in the F400 System. It also describes how to mount the Vision Mate Controller to DIN Track or to a flat surface.

**Section 3 Terminal Blocks** describes how to connect the terminal blocks.

**Section 4 RS-232C Connection** describes how to connect the RS-232C port.

**Section 5 Troubleshooting** lists the errors that may occur, along with their probable causes and remedies.

**Section 6 Inspection** provides information on inspection.

**Section 7 Specifications** provides the specifications of the F400 components.



### **WARNING**

Failure to read and understand the information provided in this manual may result in personal injury or death, damage to the product, or product failure. Please read each section in its entirety and be sure you understand the information provided in the section and related sections before attempting any of the procedures or operations given.













# PRECAUTIONS

This section provides general precautions for using the F400 Color Vision Sensor.

**The information contained in this section is important for the safe and reliable application of the F400 Color Vision Sensor. You must read this section and understand the information contained before attempting to set up or operate a F400 Color Vision Sensor.**

- 1 Safety Precautions ..... xii
- 2 General Precautions ..... xii
- 3 Export Precautions ..... xiii

## 1 Safety Precautions

-  **WARNING** Cover the terminal blocks with the Terminal Block Protection Covers. Uncovered terminal blocks can result in electric shock.
-  **WARNING** Use DC power supplies with safe extra low-voltage circuits on the secondary side for the main F400 power supply and power supplies for the terminal blocks. Excessively high voltages can result in electric shock.
-  **Caution** Do not touch fluorescent or halogen lights while the power is ON or immediately after the power is turned OFF. These lights generate heat and can cause burns.
-  **Caution** Do not use the F400 in environments with flammable or explosive gases.
-  **Caution** Install the F400 away from high-voltage equipment or motors to ensure safety during operation and maintenance.
-  **Caution** Use the power supply cables and crimp terminals of specified sizes.
-  **Caution** Turn ON the power supply after confirming the wiring.
-  **Caution** Use at the power supply voltages specified in this manual.
-  **Caution** Be sure to securely tighten the screws when mounting F400 components.
-  **Caution** Do not dismantle, repair or modify any F400 components.
-  **Caution** Dispose of F400 components as industrial waste.
-  **Caution** To prevent damage from static electricity, use a wrist strap or another device for preventing electrostatic charges when touching terminals or connector signal lines.
-  **Caution** Do not turn OFF the power while a message is being displayed indicating that processing is being performed. Data in memory will be destroyed, and the F400 may not operate correctly the next time it is started.

## 2 General Precautions

The user must operate the product according to the performance specifications described in the operation manuals.

Before using the product under conditions which are not described in the manual or applying the product to nuclear control systems, railroad systems, aviation systems, vehicles, combustion systems, medical equipment, amusement machines, safety equipment, and other systems, machines, and equipment that may have a serious influence on lives and property if used improperly, consult your OMRON representative.

Make sure that the ratings and performance characteristics of the product are sufficient for the systems, machines, and equipment, and be sure to provide the systems, machines, and equipment with double safety mechanisms.

### **3      Export Precautions**

These products are Controlled Products subject to Japanese Law.

They should not be sold, transferred, re-exported or otherwise used, disposed, and other than original usage declared to the exporter without prior notification and approval to the exporter.



# SECTION 1

## Before Installing

This section describes the precautions that must be taken when installing and operating the F400 Color Vision Sensor.

1-1	Installation Precautions .....	2
1-1-1	F400 Components .....	2
1-1-2	Installation Site .....	2
1-1-3	Installation .....	2
1-1-4	Cables .....	3
1-1-5	Camera .....	3
1-2	Confirming Package Contents .....	3
1-3	Product Availability .....	4

## 1-1 Installation Precautions

The F400 is highly reliable and resistant to most environmental factors. The following guidelines, however, must be followed to ensure reliability and optimum use of the F400.

### 1-1-1 F400 Components

Be sure to use the Camera, Camera Cable, and Console designed for the F400.

- 1, 2, 3...
1. F400-S1 Camera
  2. F150-VS Camera Cable
  3. F150-KP Console

### 1-1-2 Installation Site

Do not install the F400 in locations subject to the following conditions:

- 1, 2, 3...
1. Ambient temperatures outside of 0 to 50°C for all other F400 components
  2. Condensation due to rapid temperature fluctuations
  3. Relative humidities outside 35% to 85%
  4. Corrosive or flammable gases
  5. Dust, salt, or iron particles
  6. Direct vibration or shock
  7. Direct sunlight
  8. Water, oil, or chemical fumes or spray

### 1-1-3 Installation

#### Orientation of Controller

To improve heat dissipation, install the Controller in the following orientation only:

**CORRECT**

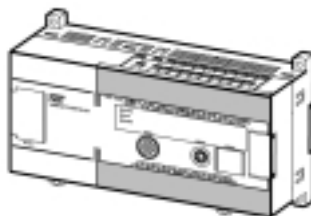

Do not install the Controller in the orientations shown in the following diagram.

**INCORRECT**

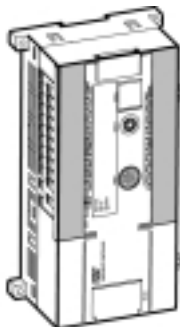

**INCORRECT**



**Ambient Temperature**

- 1, 2, 3...
1. Maintain a minimum clearance of 50 mm above and below F400 components to improve air circulation.
  2. Do not install F400 components immediately above strong heat sources, such as heaters, transformers, or large-capacity resistors.
  3. Do not let the ambient operating temperature exceed 50°C.
  4. Provide a forced-air fan or air conditioning if the ambient temperature might exceed 50°C.

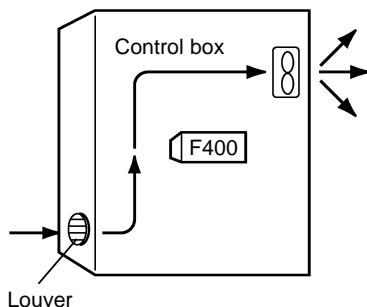

**Noise Resistance**

Use the following measures to help increase noise resistance.

- 1, 2, 3...
1. Do not install F400 components in a cabinet containing high-voltage equipment.
  2. Do not install the F400 components within 200 mm of power cables.

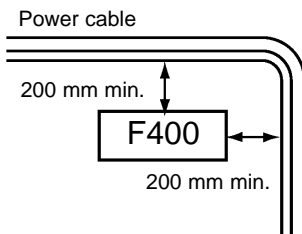

**1-1-4 Cables**

Always turn OFF the power before connecting or disconnecting cables.

**1-1-5 Camera**

The Camera's case is connected to the 0V line in the internal circuits. Heed the following precautions to prevent noise interference.

- 1, 2, 3...
1. Do not ground the Camera.
  2. Do not remove the base attached to the Camera.
  3. Do not remove the core attached to the F150-VS Camera Cable.

**1-2 Confirming Package Contents**

Check the contents of the package as soon as you receive the F400. Contact the nearest OMRON representative if any of the following items are missing.

- 1, 2, 3...
- |                                |   |
|--------------------------------|---|
| 1. F400 Vision Mate Controller | 1 |
| 2. Setup Manual (this manual)  | 1 |
| 3. Operation Manual            | 1 |
| 4. Introduction Manual         | 1 |

## **1-3 Product Availability**

Some of the products listed may not be available in some countries. Please contact your nearest OMRON sales office by referring to the addresses provided at the back of this manual.

# SECTION 2

## Product Introduction

This section describes the wiring, Camera, optical lenses, lighting modes, and light guides used in the F400. It also describes how to mount the Vision Mate Controller to DIN Track or to a flat surface.

- 2-1 Component Names and Functions ..... 6
- 2-2 Connections ..... 7
- 2-3 Power Supply and Ground ..... 7
  - 2-3-1 Crimp Terminals and Cables ..... 7
  - 2-3-2 Protective Conductor (Earth) Wiring ..... 8
  - 2-3-3 Wiring the Power Supply ..... 8
- 2-4 Camera ..... 9
- 2-5 CCTV Lens ..... 9
  - 2-5-1 Optical Chart ..... 9
  - 2-5-2 Lens ..... 10
  - 2-5-3 Extension Tubes ..... 10
- 2-6 Lighting ..... 11
  - 2-6-1 Lighting Methods ..... 11
  - 2-6-2 Light Source ..... 13
- 2-7 Mounting the Controller ..... 13
  - 2-7-1 Mounting to DIN Track ..... 13
  - 2-7-2 Mounting on a Flat Surface ..... 14

## 2-1 Component Names and Functions

The following diagram shows the terminals, connectors, and indicators on the F400 Vision Mate Controller.

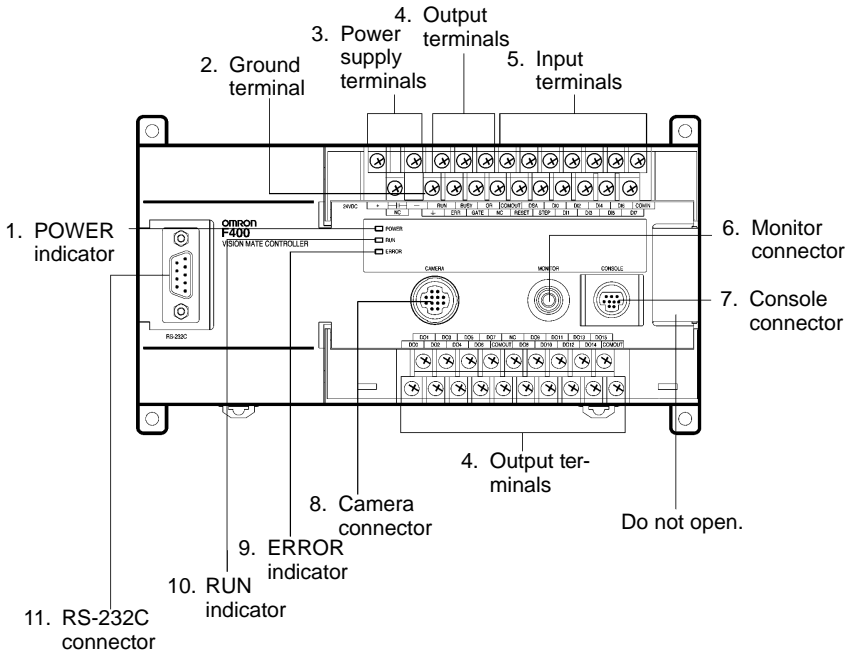

- |   |   |
|---|---|
| <ol style="list-style-type: none"> <li>1. <b>POWER Indicator</b><br/>Lit while power is ON.</li> <li>2. <b>Ground Terminal</b><br/>Wired to the ground.</li> <li>3. <b>Power Supply Terminals</b><br/>Wired to the power supply.</li> <li>4. <b>Output Terminals</b><br/>Wired to external devices, such as synchronous sensors or outputs to a PLC.</li> <li>5. <b>Input Terminals</b><br/>Wired to external devices, such as synchronous sensors or inputs from a PLC.</li> </ol> | <ol style="list-style-type: none"> <li>6. <b>Monitor Connector</b><br/>Connects to the video monitor.</li> <li>7. <b>Console Connector</b><br/>Connects to the Console.</li> <li>8. <b>Camera Connector</b><br/>Connects to the Camera.</li> <li>9. <b>ERROR Indicator</b><br/>Lit when an error occurs.</li> <li>10. <b>RUN Indicator</b><br/>Lit in RUN mode.</li> <li>11. <b>RS-232C Connector</b><br/>Connects the F400 to a computer, PLC or other external device.</li> </ol> |
|---|---|

## 2-2 Connections

Connect the basic components as shown in the following diagram. Details are provided later in this section.

**Caution** Turn OFF the power to the Controller before connecting or disconnecting cables. Connecting or disconnecting cables with power turned ON can damage peripheral devices.

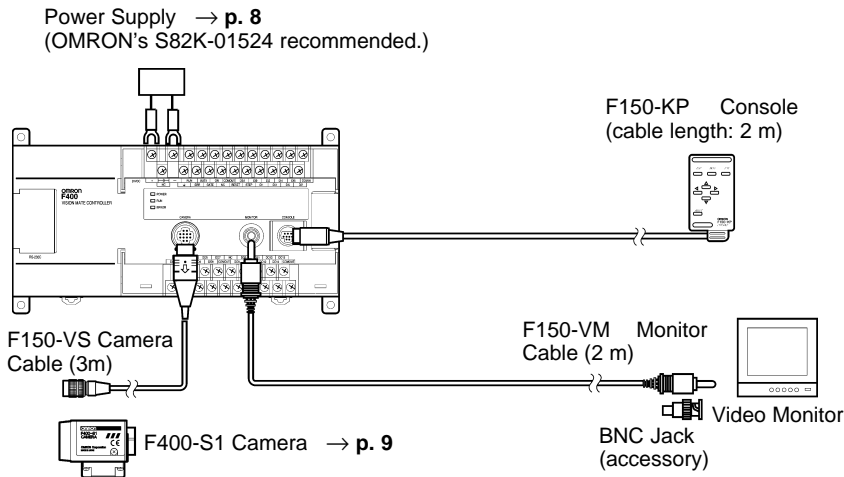

**Note** Use an NTSC monitor with an external video input terminal.

## 2-3 Power Supply and Ground

Wire the power supply and the ground to the top terminal block, and tighten the screws to a torque of between 0.5 and 0.6 N·m.

After wiring, check to make sure that the wiring is correct.

**WARNING** Cover the terminal blocks with the Terminal Block Protection Covers. Uncovered terminal blocks can result in electric shock.



### 2-3-1 Crimp Terminals and Cables

The terminal block uses M3 terminal screws. Use appropriate crimp terminals for M3 screws, as shown below.

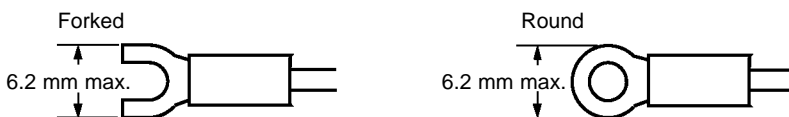

**Applicable wire size:** Insulated wire of 1.31 to 1.65 mm<sup>2</sup> (AWG16 to AWG15)

### 2-3-2 Protective Conductor (Earth) Wiring

Wire the ground as shown in the following diagram.

**Caution** Use an appropriate ground. An insufficient ground can affect F400 operation or result in damage to F400 components.

- To avoid damage to the equipment, do not share the protective conductor wiring with any other devices nor wire the protective conductor terminal to the girder. Be sure to wire the protective conductor of the equipment independently.
- Keep the ground line as short as possible.

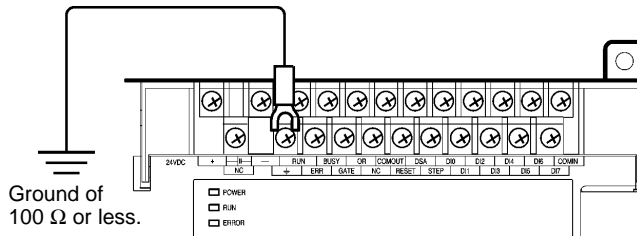

### 2-3-3 Wiring the Power Supply

**WARNING** Use a DC power supply with safe extra low-voltage circuits on the secondary side. Excessively high voltages can result in electric shock.



Use a power supply with the following specifications. We recommend using OMRON's S82K-01524 Power Supply.

Item	Specification
Output current	0.6 A min.
Power supply voltage	24 VDC +10%/−15%

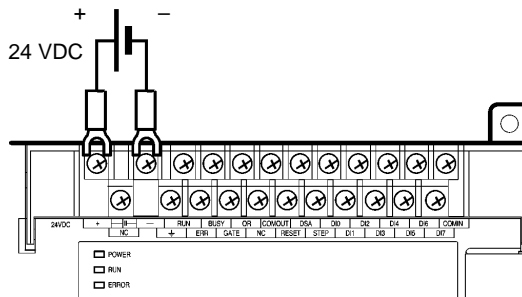

- Note**
1. Wire the Power Supply Unit independently of other devices. In particular, keep the power supply wired separately from inductive loads.
  2. Keep the power supply cable as short as possible.



## 2-4 Camera

The Camera is designed for the F400.

### Mounting the Camera

The specified camera distance is only an approximation. Mount the Camera so that it can be adjusted to either side of the specified distance from the measurement object.

Unit: mm

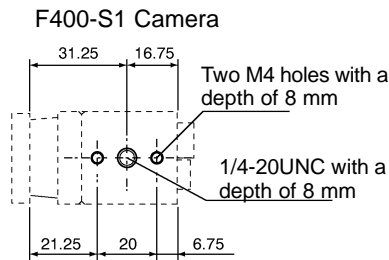

## 2-5 CCTV Lens

Refer to the following graph to select the appropriate Lens and Extension Tube. The lens will differ depending on the size of the measurement object and the distance from the Camera.

### 2-5-1 Optical Chart

The values in the following chart are approximations, and the Camera must be adjusted after it is mounted.

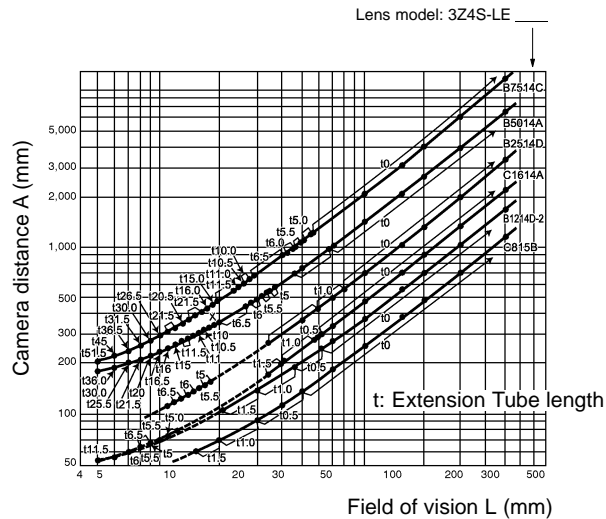

The X axis of the graph shows field of vision L (mm), and the Y axis shows the camera distance A (mm). The curves on the graph indicate different lenses, and the “t” values indicates the lengths of the Extension Tubes.

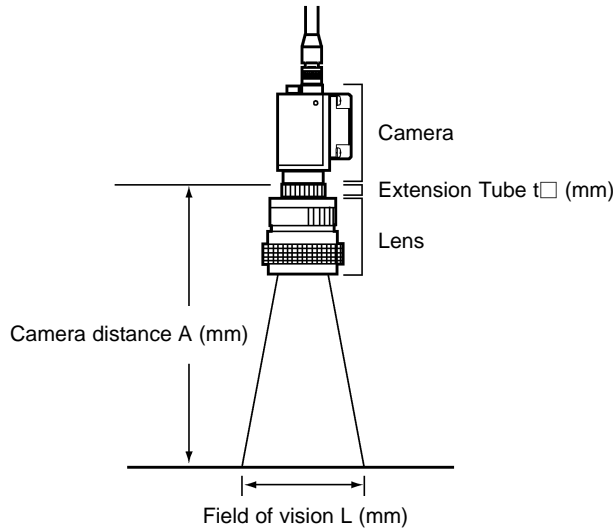

### 2-5-2 Lens

Lens	Focal length	Bright-ness	Maximum outer diameter	Total length	Filter size
3Z4S-LE C418DX	4.8 mm	F1.8	40.5-mm dia.	35.5 mm	M40.5 × P0.5
3Z4S-LE B618CX-2	6.5 mm	F1.8	48-mm dia.	42 mm	
3Z4S-LE C815B	8.5 mm	F1.5	42-mm dia.	40 mm	
3Z4S-LE B1214D-2	12.5 mm	F1.4	42-mm dia.	50 mm	M27 × P0.5
3Z4S-LE C1614A	16.0 mm	F1.4	30-mm dia.	33 mm	
3Z4S-LE B2514D	25.0 mm	F1.4	30-mm dia.	37.3 mm	
3Z4S-LE B5014A	50.0 mm	F1.4	48-mm dia.	48 mm	M46 × P0.75
3Z4S-LE B7514C	75.0 mm	F1.4	62-mm dia.	79 mm	M58 × P0.75

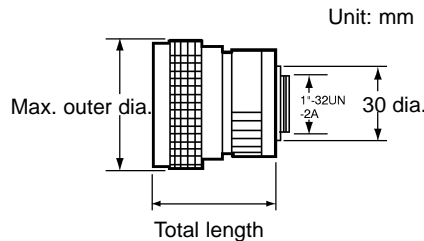

### 2-5-3 Extension Tubes

One or more Extension Tubes are inserted between the lens and the Camera to focus the Camera image. Use a combination of one or more of the six sizes of tube to achieve the required length.

- Note**
- Do not use the 0.5-mm and 1.0-mm Extension Tubes attached to each other. Since these Extension Tubes are placed over the threaded section of the Lens or other Extension Tube, the connection may loosen when more than one 0.5-mm or 1.0-mm Extension Tube are used together.

- Reinforcement may be required for combinations of Extension Tubes exceeding 30 mm if the Camera is subject to vibration.

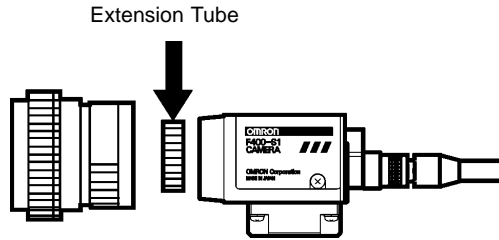

Model	Maximum outer diameter	Length
3Z4S-LE EX-C6	31 dia.	Set of 6 tubes 0.5 mm, 1 mm, 5 mm, 10 mm, 20 mm, and 40 mm

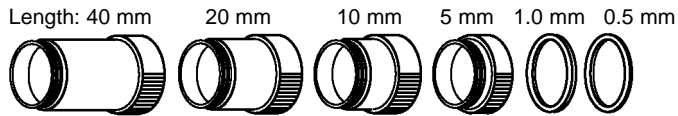

## 2-6 Lighting

A stable image must be obtained to ensure accurate inspection. Use appropriate lighting for the application and the measurement object.

### 2-6-1 Lighting Methods

#### Back Lighting

A stable, high-contrast image can be obtained using back lighting.

**Applications:** Inspection of exterior shape or positioning inspection

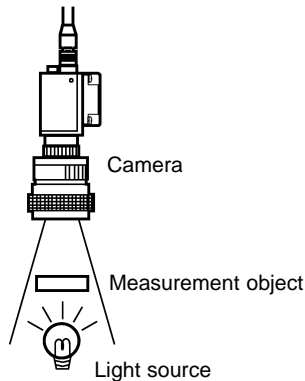

**Reflected Lighting**

**Ring Lights**

Light is shone uniformly on the measurement object.

**Applications:** Surface inspections

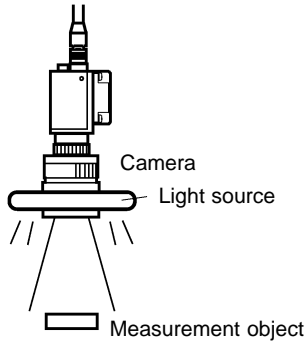

**Oblique Lighting**

Detection can be made utilizing the difference in regular and diffuse reflected light.

**Applications:** Inspections for surface gloss

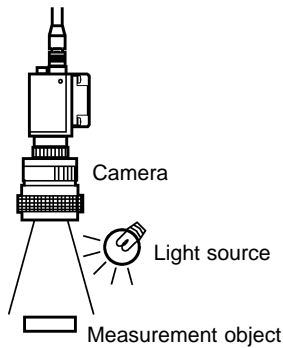

**Coaxial Lighting**

A stable image can be obtained with few shadows from uneven surfaces on the measurement object.

**Applications:** Surface inspections, positioning, and hole inspections of comparatively small objects

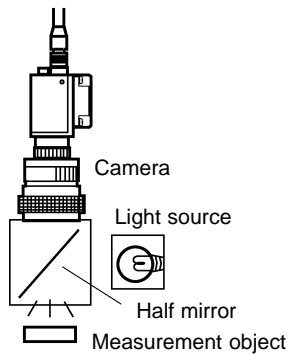

## 2-6-2 Light Source

### White Balance

Depending on the environment or the kind of light, the image read by the Camera may appear tinted, even if it is white.

For correct measurement, the sensitivity of R.G.B. must be adjusted so that the image will really appear in white in accordance with the light source. This is called the adjustment of white balance.

**Note** Adjust the white balance before setting the light and adjusting the image. Refer to *White Balance* in the *F400 Color Vision Sensor Operation Manual*.

## 2-7 Mounting the Controller

The Vision Mate Controller can be mounted to DIN Track or a flat surface.

### 2-7-1 Mounting to DIN Track

The Vision Mate Controller can be easily mounted to or removed from 35-mm DIN Track.

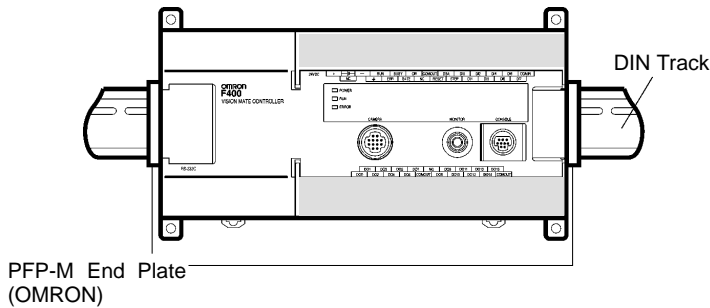

The following DIN Tracks are available from OMRON.

Model	Length
PFP-100N	1 m
PFP-50N	50 cm
PFP-100N2	1 m

### Mounting the Controller

Hook the Controller into the DIN Track as shown in the diagram and then press in at the bottom until the Controller locks into place.

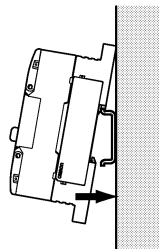

**Removing the Controller**

Use a screwdriver to pull the hook down and then pull out the Controller from the bottom.

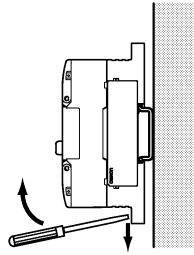

**2-7-2 Mounting on a Flat Surface**

Mount the Controller using the holes and dimensions shown in the following diagram.

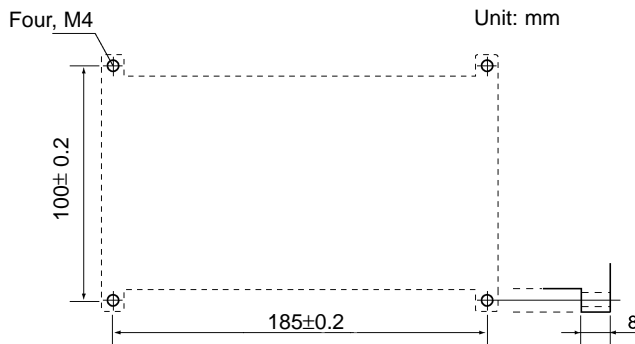

**Caution** Do not use screw-locking materials that contain ingredients harmful to ABS or polycarbonate resins. The Controller will be damaged.

# SECTION 3

## Terminal Blocks

This section describes how to connect the terminal blocks.

3-1	Crimp Terminals and Cables .....	16
3-2	Specifications .....	16
3-3	Terminals .....	17

### 3-1 Crimp Terminals and Cables

The terminal block uses M3 terminal screws. Use appropriate crimp terminals for M3 screws, as shown below. Tighten the screws to a torque of between 0.5 and 0.6 N·m. After wiring, check to make sure that the wiring is correct.

**! WARNING** Cover the terminal blocks with the Terminal Block Protection Covers. Uncovered terminal blocks can result in electric shock.

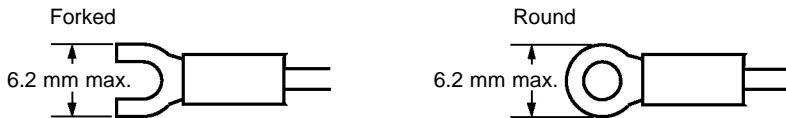

**Applicable wire size:** Insulated wire of 1.31 to 1.65 mm<sup>2</sup> (AWG16 to AWG15)

### 3-2 Specifications

**! WARNING** Use a DC power supply with safe extra low-voltage circuits on the secondary side. Excessively high voltages can result in electric shock.



#### Input Specifications

Item	F400-C10E (NPN model)	F400-C15E (PNP model)
Input voltage	12 to 24 VDC ±10%	
ON current	3 to 15 mA	
ON voltage	8.8 V max.	
OFF current	0.1 mA max.	
OFF voltage	4.5 V min.	
ON delay	RESET input: 10 ms max. Others: 0.5 ms max.	
OFF delay	RESET input: 15 ms max. Others: 0.7 ms max.	
Internal circuits		

#### Output Specifications

Item	F400-C10E (NPN model)	F400-C15E (PNP model)
Output voltage	12 to 24 VDC ±10%	
Load current	45 mA max.	
ON residual voltage	2 V max.	
OFF leakage current	0.1 mA max.	
Internal circuits		



### 3-3 Terminals

There are three kinds of COM OUT (\*1 to \*3) for output terminals. Connect the terminals while referring to the following tables.

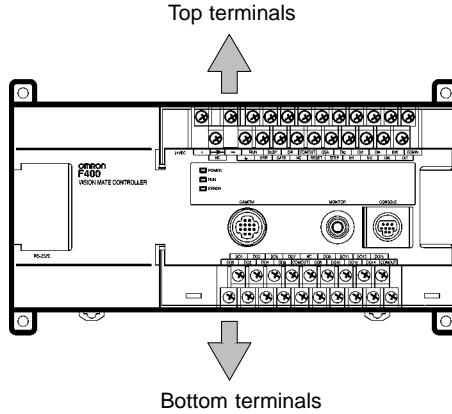

#### Top Terminals

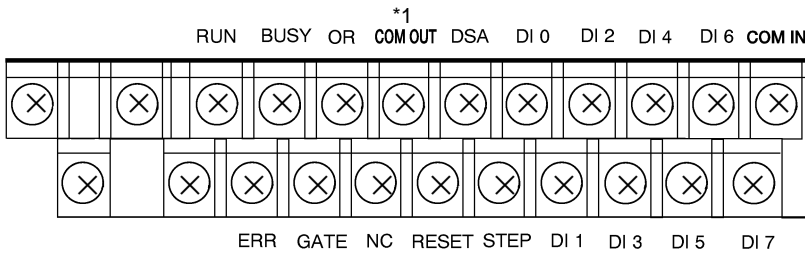

Name/Application		Name/Application	
RUN		ERR	Error output
BUSY		GATE	
OR		NC	Not connected
COM OUT (*1)	For RUN, ERR, BUSY, GATE, and OR	RESET	Resets F400
DSA	Command inputs	STEP	Command inputs
DI 0		DI 1	
DI 2		DI 3	
DI 4		DI 5	
DI 6		DI 7	
COM IN		---	

Bottom Terminals

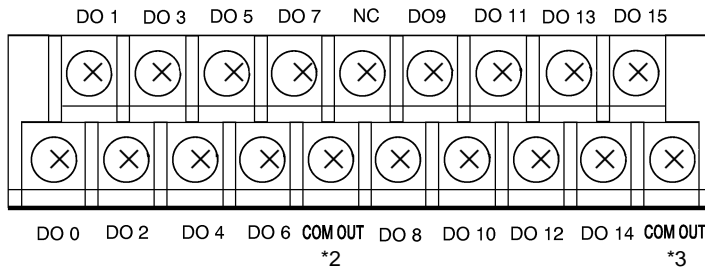

Name/Application		Name/Application	
DO 1	Measurement results output	DO 0	Measurement results output
DO 3		DO 2	
DO 5		DO 4	
DO 7		DO 6	
NC	Not connected	COM OUT (*2)	For DO 0 to DO 7
DO 9	Measurement results output	DO 8	Measurement results output
DO 11		DO 10	
DO 13		DO 12	
DO 15		DO 14	
---		COM OUT (*3)	For DO 8 to DO 15

**Caution** If RESET is input immediately after power is turned ON, it will be ignored. When using RESET input to synchronize execution timing, wait at least 1 s after turning ON the F400 power supply before turning ON the RESET terminal.

**Caution** Do not reverse the connections of the signal terminals and COM terminals.

# SECTION 4

## RS-232C Connection

This section describes how to connect the RS-232C port.

4-1	Connector .....	20
4-2	Wiring .....	20
4-3	Connection .....	21

## 4-1 Connector

Use an appropriate 9-pin D-SUB female connector. The pin numbers and names are shown below.

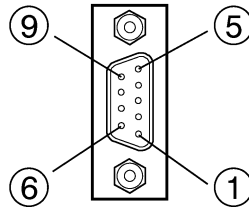

Pin	Signal	Name
1	FG (GND)	Frame ground
2	SD (TXD)	Send Data
3	RD (RXD)	Receive Data
4	RS (RTS)	Request to Send
5	CS (CTS)	Clear to Send
6	NC	Not connected
7	NC	Not connected
8	NC	Not connected
9	SG (GND)	Signal ground

The following plug and hood are recommended and are available from OMRON.

Model	Model No.
Plug	XM2A-0901
Hood	XM2S-0911

## 4-2 Wiring

Use only shielded RS-232C cable.

### Standard Connections

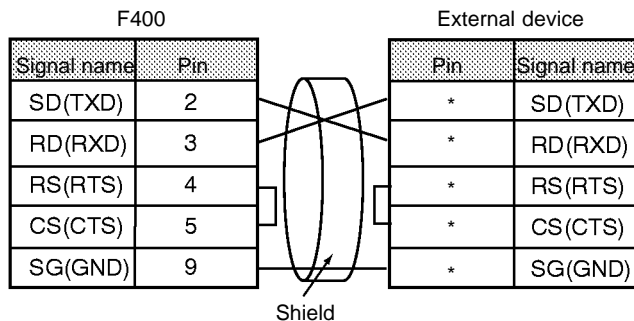

Connections for RS/CS Control

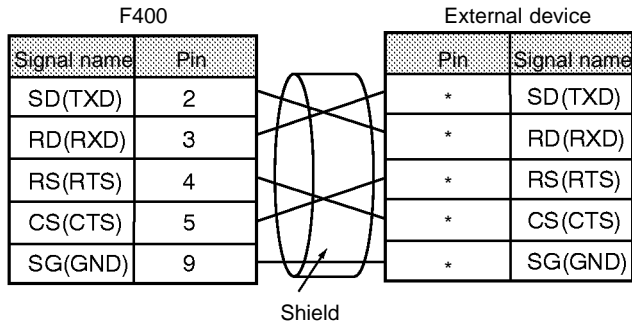

**Note** Pin numbers on the external device will depend on the device being connected. Refer to the manual for the device being connected.

### 4-3 Connection

Align the connector with the socket and press the connector straight into place. Tighten the two screws on the edges of the connector.

**Caution** Always turn OFF the power supply before connecting or disconnecting cables. Peripheral devices can be damaged if connected or disconnected with the power supply turned ON.

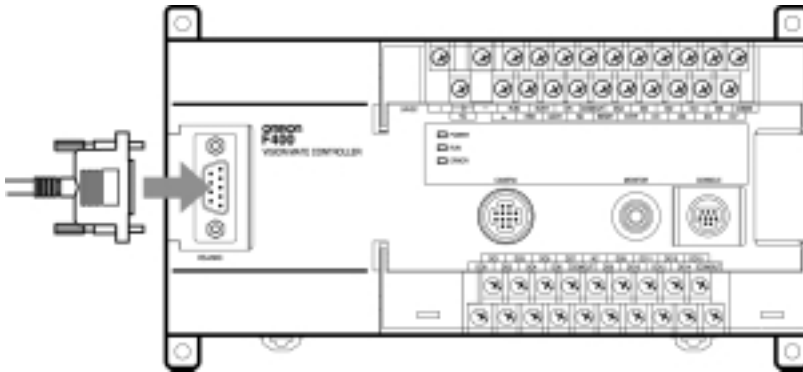

**Note** Always tighten the connector screws.

# SECTION 5

## Troubleshooting

This section lists the errors that may occur, along with their probable causes and remedies.

5-1	Connection Errors . . . . .	24
5-2	Errors during Menu Operation . . . . .	24
5-3	Terminal Block Errors . . . . .	24
5-4	RS-232C Communications Errors . . . . .	24

## 5-1 Connection Errors

Problem	Probable cause
The POWER indicator is not lit.	The Power Supply is not connected properly.
	The supply voltage is not 24 VDC $+10\%/_{-15\%}$ .
The measurement results do not appear on the Video Monitor.	The F400 is not in Monitor or Run mode.
The Video Monitor is blank.	The power to the Video Monitor is not ON.
	The Monitor Cable is not connected properly.
	The Video Monitor is malfunctioning.
Cannot make key inputs from the Console.	The Console Cable is not correctly connected.
Camera images do not appear on the screen.	The Camera Cable is not properly connected.
	The lens cap has not been removed.
	The lens diaphragm is opened or closed too far.
	The shutter speed is not suitable.
	The lighting method is not suitable.
The Video Monitor image is not clear.	There is electrical noise entering from the power supply or cables.
	The Monitor Cable is not correctly connected.
There is color displacement on the Video Monitor image.	Infrared-cutting filter is necessary when using a halogen lamp without an infrared-cutting function.
	White balance adjustment is needed.

## 5-2 Errors during Menu Operation

Problem	Probable cause
The measurement results are not displayed on the Video Monitor.	The F400 is not in Monitor or Run mode.
Menu characters are not displayed on the Video Monitor.	Characters are set to be deleted in the System/Set Key Operation.
Display image cannot be switched.	Do the same operation again.

## 5-3 Terminal Block Errors

Problem	Probable cause
Trigger signals (input signals) are not received.	The cables are not correctly wired.
	The signal line is disconnected.
	The F400 is not in Monitor or Run mode.
Signals cannot be output externally.	The trigger signal has not been input.
	The cables are not correctly wired.
	The signal line is disconnected.
	The F400 is not in Run mode.

## 5-4 RS-232C Communications Errors

Problem	Probable cause
No communications are possible.	The cables are not correctly wired.
	The communications specifications do not match those of the external device.
	The F400 is not in Run mode.
The Unit operates well initially, but after a while there is no response from the F400.	The reception buffer on the external device (e.g., computer) is full. Check that settings allow the data to be properly received.

# SECTION 6

## Inspection

This section provides information on inspection.

6-1	Regular Inspections .....	26
-----	---------------------------	----





## 6-1 Regular Inspections

To maintain the F400 in the best condition, perform the following regularly.

- Lightly wipe off dirt with a soft cloth.
- Clean the Lens with a special lens cloth or airbrush.

Inspection point	Details	Tools required
Power supply	The voltage measured at the power supply terminals on the terminal block must be 24 VDC (20.4 VDC to 26.4 VDC).	Circuit tester
Ambient temperature	The operating ambient temperature inside the cabinet must be between 0 and 50°C.	Thermometer
Ambient humidity	The operating ambient humidity inside the cabinet must be between 35% and 85% RH.	Hygrometer
Installation	Each component must be firmly secured. Each cable connector must be correctly inserted and locked. The Cameras must be firmly secured. The camera lens mounts must be firmly secured.	Phillips screwdriver

 **Caution** Turn OFF the power and take safety precautions before conducting inspections. Electrical shock can result from attempting safety inspections with the power turned ON.

 **Caution** Do not use thinners or benzene. They will damage F400 components.

# SECTION 7

## Specifications

This section provides the specifications of the F400 components.

7-1	F400 Vision Mate Controller .....	28
7-2	K150-KP Console .....	29
7-3	Camera .....	30
7-4	Cables .....	31

# 7-1 F400 Vision Mate Controller

F400-C10E/F400-C15E

Unit: mm

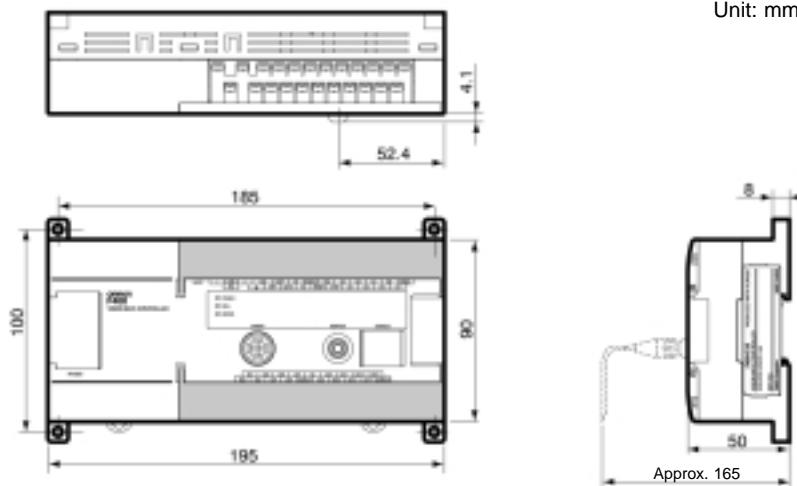

Item	Specification	
	F400-C10E	F400-C15E
Output type	NPN	PNP
Supply voltage	24 VDC (20.4 VDC to 26.4 VDC)	
Current consumption	0.6 A max.	
Insulation resistance	20 M Ω min. between all DC external terminals and GR terminal (at 100 VDC) (with the built-in surge absorber removed)	
Dielectric strength	1,000 VAC, 50/60 Hz between all DC external terminals and GR terminal (with the built-in surge absorber removed)	
Leakage current	10 mA max.	
Noise resistance	1500 Vp-p; pulse width: 0.1μs/ 1μs; rising time: 1 ns (pulse)	
Vibration resistance	10 to 150 Hz; single amplitude: 0.35 mm; maximum acceleration: 50 m/s <sup>2</sup>	
Shock resistance	Peak acceleration: 150 m/s <sup>2</sup>	
Ambient temperature	0 to 50 °C	
Ambient humidity	35% to 85% (with no condensation)	
Ambient environment	No corrosive gases	
Storage temperature	-25 to 65 °C	
Protection class	Class I (with protective conductor terminal)	
Degree of protection	IEC60529 IP20 (with built-in panel)	
Processing resolution	512×484 (H×V)	
External I/O	RS-232C×1, Terminal block×1 (input: 11, output: 21), Camera×1, Monitor×1	
Weight	Approx. 600 g (without cable)	

## 7-2 K150-KP Console

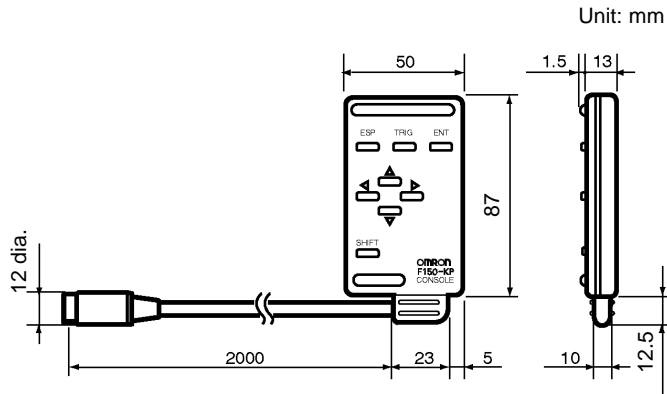

Item	Specification
Vibration resistance	10 to 150 Hz; single amplitude: 0.15 mm
Shock resistance	196 m/s <sup>2</sup>
Ambient temperature	0 to 50 °C
Ambient humidity	35% to 85% (with no condensation)
Ambient environment	No corrosive gases
Storage temperature	-25 to 65 °C
Degree of protection	IEC60529 IP20 (in-panel)
Length	2 m
Minimum bending radius	75 mm
Weight	Approx. 240 g (without cable)

## 7-3 Camera

### F400-S1 Camera

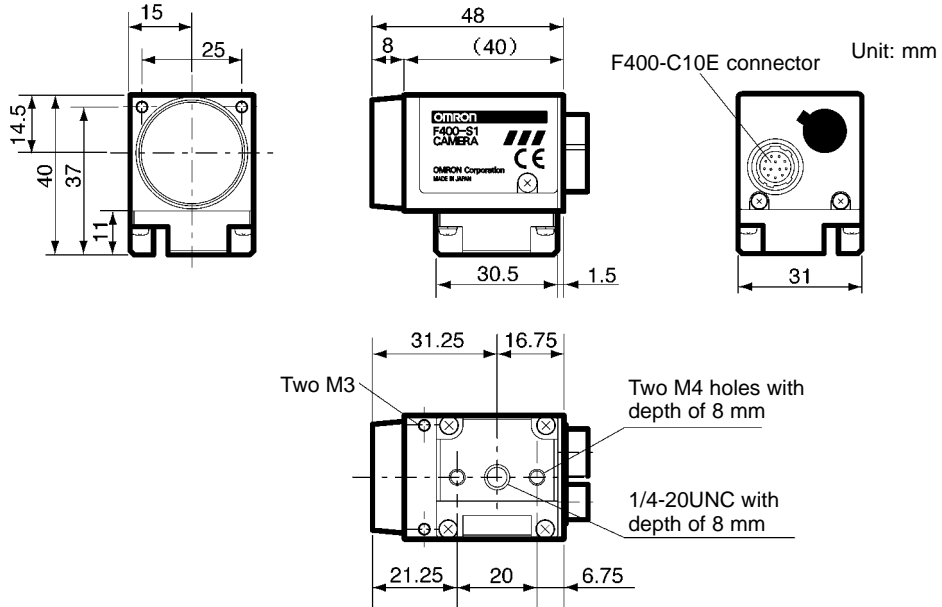

Item	Specification
Supply voltage	12 VDC (10 VDC to 15 VDC)
Current consumption	0.1 A max.
Vibration resistance	10 to 150 Hz; single amplitude: 0.35 mm; maximum acceleration: 50 m/s <sup>2</sup>
Shock resistance	Peak acceleration: 150 m/s <sup>2</sup>
Ambient temperature	0 to 50 °C
Ambient humidity	35% to 85% (with no condensation)
Ambient environment	No corrosive gases
Storage temperature	-25 to 60 °C
Picture element	1/3" Interline CCD (reading all pixels)
Effective pixels	659 × 494 (H × V)
Synchronization	External sync. via horizontal sync signal
Shutter speed	Electronic shutter: 1/100 s, 1/500 s, 1/2000 s, 1/10000 s
Lens mounting	C mount
Weight	Approx. 70 g (without cable and mounting base)

## 7-4 Cables

### F150-VS Camera Cable

Item	Specification
Vibration resistance	10 to 150 Hz; single amplitude: 0.15 mm
Shock resistance	196 m/s <sup>2</sup>
Ambient temperature	0 to 50 °C
Ambient humidity	35% to 85% (with no condensation)
Ambient environment	No corrosive gases
Storage temperature	-25 to 65 °C
Length	3 m
Minimum bending radius	75 mm

### F150VM Monitor Cable

Item	Specification
Vibration resistance	10 to 150 Hz; single amplitude: 0.15 mm
Shock resistance	196 m/s <sup>2</sup>
Ambient temperature	0 to 50 °C
Ambient humidity	35% to 85% (with no condensation)
Ambient environment	No corrosive gases
Storage temperature	-25 to 65 °C
Length	2 m
Minimum bending radius	50 mm

# Revision History

A manual revision code appears as a suffix to the catalog number on the front cover of the manual.

Cat. No. Z130-E1-1

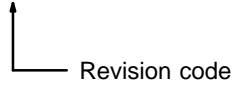

The following table outlines the changes made to the manual during each revision. Page numbers refer to the previous version.

Revision code	Date	Revised content
1	May 1999	Original production