

# ■ XW2B-40J6-4A

This Servo Relay Unit connects to the following OMRON Position Control Units. Communications are supported.

- CS1W-NC213/-NC233/-NC413/-NC433
- CJ1W-NC213/-NC233/-NC413/-NC433

## ● External Dimensions

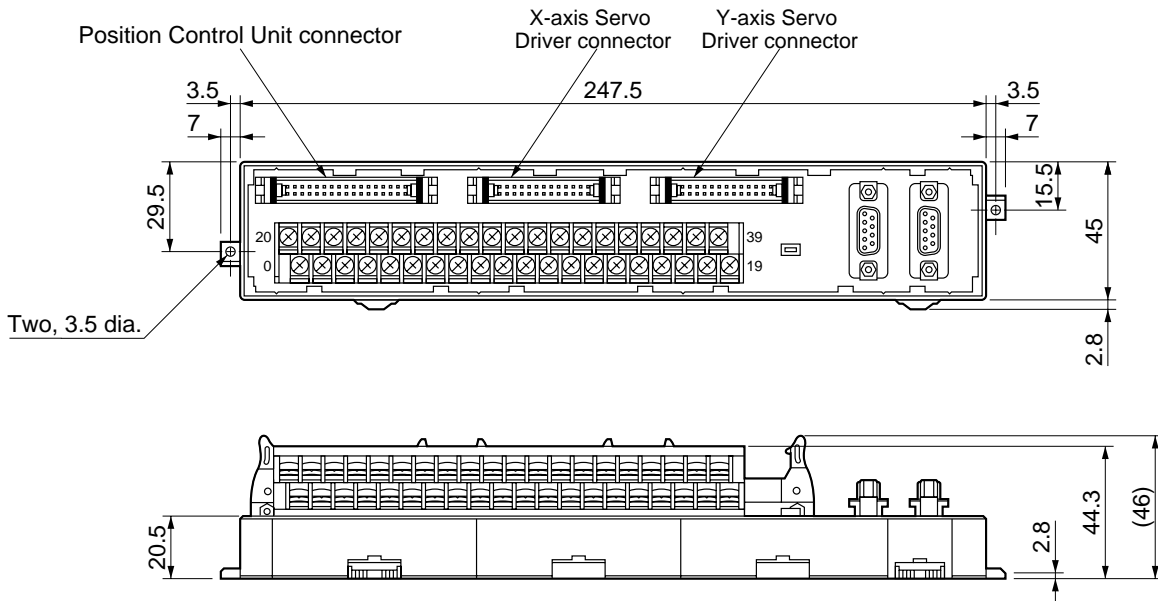

**Note** Terminal Block pitch: 7.62 mm.

## ● Wiring

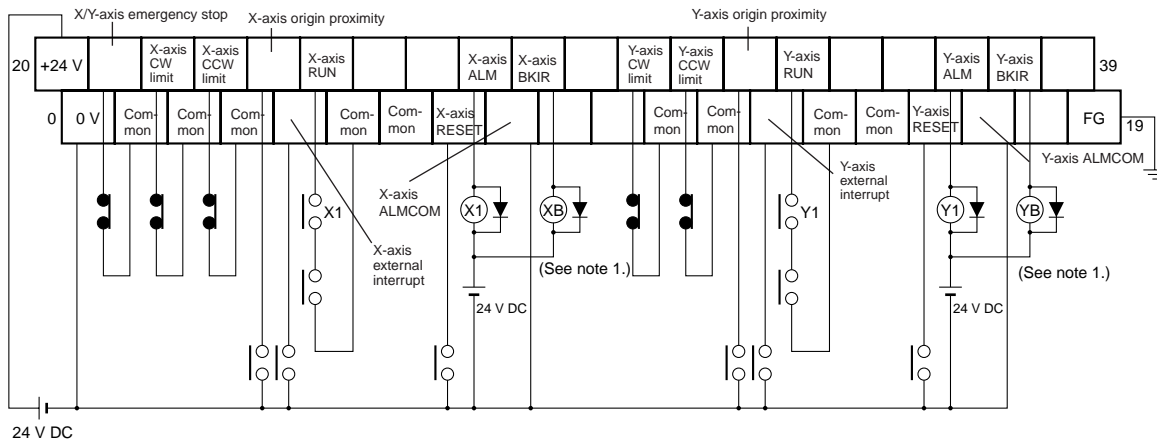

- Note**
1. The XB contact is used to turn ON/OFF the electromagnetic brake.
  2. Do not connect unused terminals.
  3. The 0 V terminal is internally connected to the common terminals.
  4. The following crimp terminal is applicable: R1.25-3 (round with open end).