

● Wiring

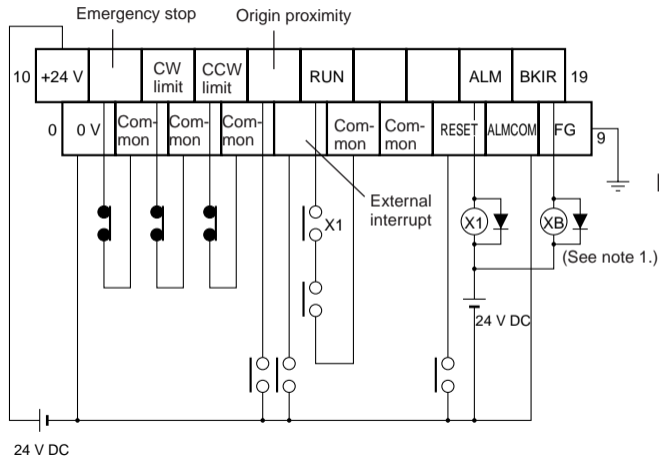

- Note**
1. The XB contact is used to turn ON/OFF the electromagnetic brake.
 2. Do not connect unused terminals.
 3. The 0 V terminal is internally connected to the common terminals.
 4. The following crimp terminal is applicable: R1.25-3 (round with open end).