

SRT2-MD32ML

SRT2-MD32ML-1

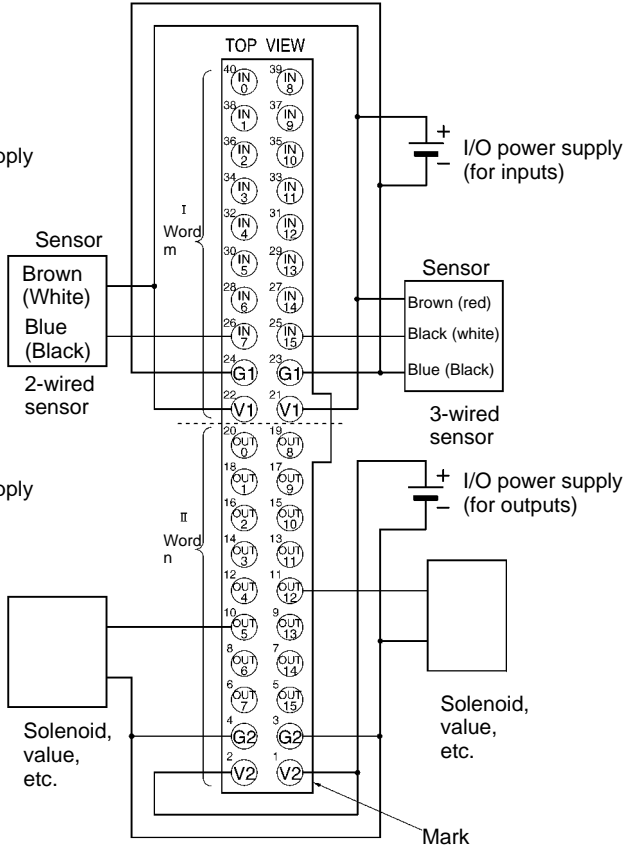
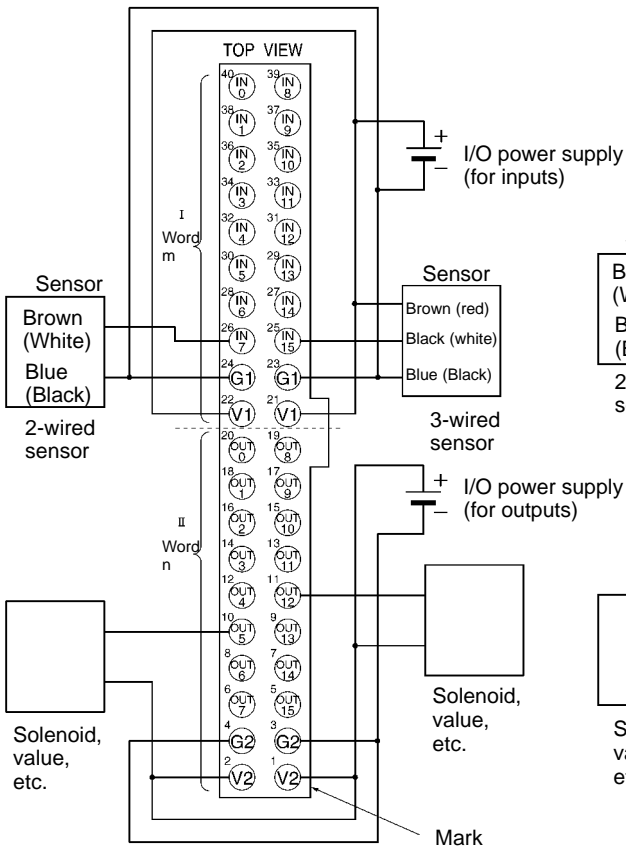
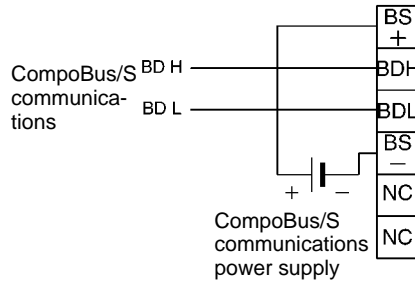
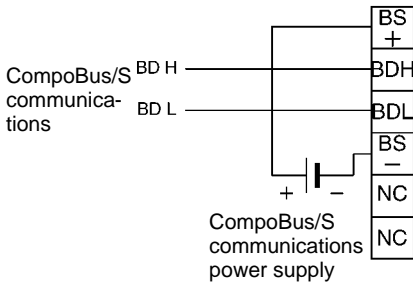

Note In accordance with the changes in the standards for photoelectric sensors and proximity sensors, wire colors have been changed. Colors in parentheses are the old wire colors.