

CN1

I/O word "n"

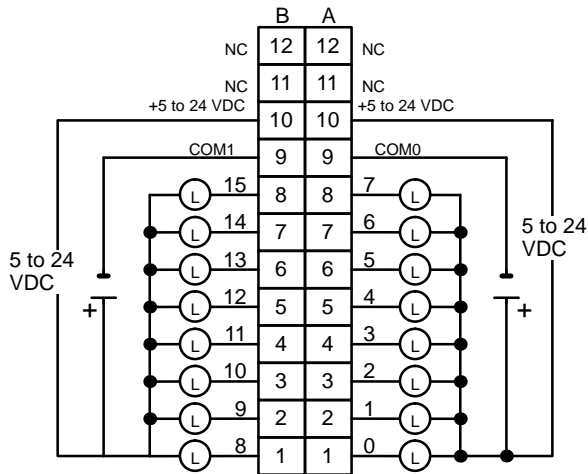

CN2

I/O word "n+1"

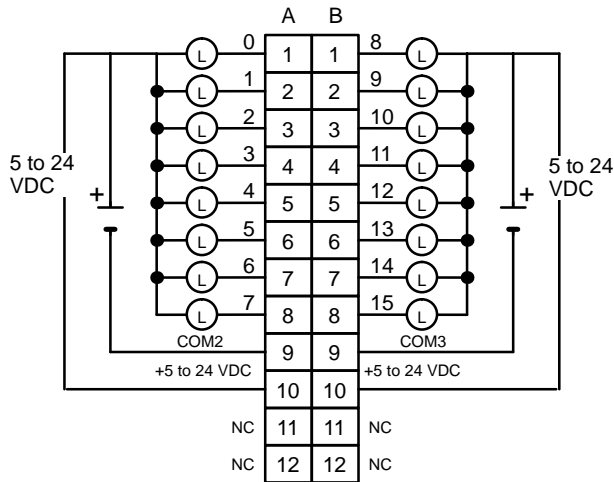

- Note**
1. I/O word "n" is determined by the unit number setting ($n = \text{CIO } 2000 + 10 \times \text{unit number}$).
 2. The Unit will have 32 static output points when pin 1 of it's DIP switch is OFF.