

# Guardmaster<sup>®</sup> IMP

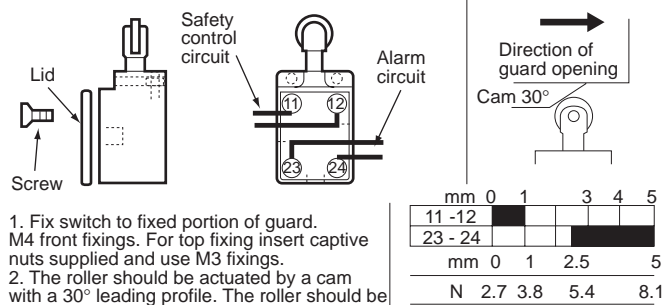
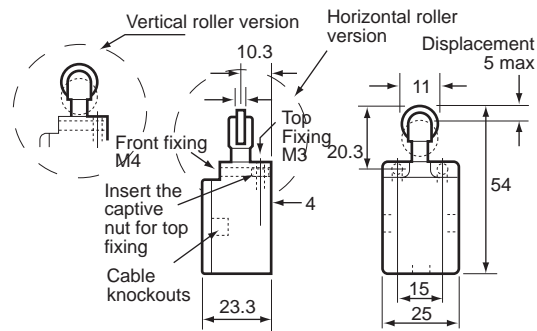

1. Fix switch to fixed portion of guard. M4 front fixings. For top fixing insert captive nuts supplied and use M3 fixings.
2. The roller should be actuated by a cam with a 30° leading profile. The roller should be depressed by the cam at all guard positions other than fully closed. A stop should be fitted if necessary.

Contact rating : 250Vac/2A 100Vac/5A.  
 Operating temp. : -25°C to 80°C.  
 Operating life : 10 x 10<sup>6</sup>  
 Protection : IP30.  
 Case : Glass filled polyester UL approved.  
 Roller : Stainless steel.

Contact movement in relation to roller plunger displacement & operating force.

Guargmaster Ltd.  
 Hindley Green Industrial Estate,  
 Wigan, Lancashire, England.  
 WN2 4HR  
 Tel 01942 255166  
 Fax 01942 523259

Pub No 577P