

DC drives

**SIEIDrive**



**TPD32**

■ ■ ■ ■ ... Instruction manual

**GEFRAN**

*Thank you for choosing this Gefran product.*

*We will be glad to receive any possible information which could help us improve this manual. The e-mail address is the following: [techdoc@gefran.com](mailto:techdoc@gefran.com).*

*Before using the product, read the safety instruction section carefully.*

*Keep the manual in a safe place and available to engineering and installation personnel during the product functioning period.*

*The manufacturer has the right to modify products, data and dimensions without notice.*

*The data can only be used for the product description and they can not be understood as legally stated properties.*

*All rights reserved*

*This manual is updated according the software version V.9.3XX.*

*Variation of the number replacing "X" have no influence on the functionality of the device.*

*The identification number of the software version can be read on the converter nameplate or on the label on the EPROM memories mounted on the regulation card.*

## Table of Contents

|   |          |
|---|----------|
| SAFETY SYMBOL LEGEND .....  | XIV      |
| BLOCK DIAGRAM LEGEND .....  | XIV      |
| <b>1 - SAFETY PRECAUTIONS - PRECAUTIONS DE SECURITÉ .....</b>             | <b>1</b> |
| <b>2 - DESCRIPTION, COMPONENT IDENTIFICATION AND SPECIFICATIONS .....</b> | <b>1</b> |
| 2.1 GENERAL .....   | 1        |
| Functions and features (Overview) .....                                   | 3        |
| 2.2 UPON DELIVERY INSPECTION PROCEDURES .....                             | 4        |
| Storage, Transport .....  | 4        |
| 2.2.1 Device setting .....  | 4        |
| 2.3 DRIVE KEYPAD DESCRIPTION .....  | 6        |
| Keypad .....  | 6        |
| LEDs .....  | 7        |
| 2.4 SPECIFICATIONS .....  | 7        |
| 2.4.1 Standards .....   | 7        |
| 2.4.2 AC Input .....  | 8        |
| 2.4.3 Output .....  | 9        |
| Output current .....  | 10       |
| Output voltage .....  | 11       |
| Field circuit .....   | 11       |
| 2.4.4 Control section .....   | 12       |
| 2.4.5 Accuracy .....  | 13       |
| 2.5 DIMENSION AND WEIGHTS .....   | 14       |
| 2.6 WATT LOSS .....   | 19       |
| 2.7 MOTORS, ENCODER, TACHOMETER .....                                     | 20       |
| 2.7.1 Motors .....  | 20       |
| 2.7.2 Encoder / Tachometer .....  | 22       |
| <b>3 - INSTALLATION GUIDELINES .....</b>                                  | <b>1</b> |
| 3.1 PERMISSIBLE AMBIENT CONDITION .....                                   | 1        |
| 3.2 DISPOSAL OF THE DEVICE .....  | 2        |
| 3.3 MOUNTING THE DEVICE .....   | 2        |
| <b>4 - WIRING PROCEDURES .....</b>  | <b>1</b> |
| 4.1 REMOVING THE FRONT COVER .....  | 1        |
| Terminal Assignments/Cable Sections .....                                 | 1        |
| 4.2 WIRING THE DRIVE .....  | 1        |
| 4.3 POWER SECTION .....   | 2        |
| 4.4 REGULATION SECTION .....  | 6        |
| 4.4.1 R-TPD32 Regulation Card .....                                       | 6        |
| 4.5 SERIAL INTERFACE .....  | 12       |
| 4.5.1 Description .....   | 12       |
| 4.5.2 RS485 serial interface connector description .....                  | 13       |

|   |    |
|---|----|
| 4.6 INPUT/OUTPUT EXPANSION CARD TBO.....  | 14 |
| 4.6.1 Assignment of the plug-in terminal strip (terminals 1...15) for Option Card TBO ..... | 14 |
| 4.6.2 Fitting the option card .....   | 15 |
| 4.7 DIGITAL ENCODER INTERFACE DEII.....   | 16 |
| 4.7.1 Description.....  | 16 |
| 4.7.2 Terminal Assignment.....  | 17 |
| 4.8 STANDARD CONNECTION DIAGRAMS .....  | 18 |
| 4.9 CIRCUIT PROTECTION .....  | 22 |
| 4.9.1 Fuses .....   | 22 |
| 4.9.2 Fuses selection when the Overload function is activated .....                         | 25 |
| 4.9.3 Internal Fuses .....  | 26 |
| 4.9.4 AC input contactors.....  | 27 |
| 4.9.5 Control power protection.....   | 27 |
| 4.10 REACTORS / FILTERS.....  | 28 |
| 4.10.1 AC input choke.....  | 28 |
| 4.10.2 Interference suppression filters.....  | 30 |
| 4.11 ENGINEERING NOTES .....  | 31 |
| Potentials of the regulator section.....  | 31 |
| External devices.....   | 32 |
| Connection cables .....   | 32 |

## **5 - CONVERTER OPERATION..... 1**

|   |   |
|---|---|
| 5.1 KEYPAD .....  | 1 |
| 5.1.1 LEDs .....  | 1 |
| 5.1.2 Moving inside a menu .....                                      | 2 |
| 5.1.3 Displaying parameters .....                                     | 2 |
| 5.1.4 Changing / Saving parameters / Password .....                   | 3 |
| Changing numerical values and text.....                               | 3 |
| Selection from predefined values.....                                 | 4 |
| Autotuning of Analog input .....                                      | 4 |
| Parameters Saving .....   | 5 |
| Entering a password .....   | 5 |
| General unlocking of the password.....                                | 6 |
| 5.1.5 Operating the drive via the Keypad .....                        | 6 |
| 5.1.5.1 Starting and stopping the drive .....                         | 7 |
| Enabling the converter .....  | 7 |
| Disabling the converter .....   | 7 |
| Start / Stop .....  | 7 |
| 5.1.5.2 Failure register / Acknowledging alarms .....                 | 8 |
| Clearing the failure register .....                                   | 8 |
| Acknowledging a failure alarm .....                                   | 9 |
| Acknowledging when several failure alarms occur at the same time..... | 9 |
| 5.1.5.3 Motor potentiometer function .....                            | 9 |

|   |          |
|---|----------|
| Acceleration, Deceleration .....  | 9        |
| Changing rotation direction .....   | 10       |
| Resetting the speed reference value .....                                   | 10       |
| 5.1.5.4 Jog function.....   | 10       |
| 5.2 MENU STRUCTURE.....   | 11       |
| 5.3 COMMISSIONING .....   | 35       |
| 5.3.1 Setting jumpers and switch.....                                       | 35       |
| 5.3.2 Checking the wiring and the auxiliary voltages.....                   | 36       |
| 5.3.3 Basic settings of the converter.....                                  | 37       |
| 5.3.4 START UP procedures.....  | 38       |
| Motor data .....  | 38       |
| Limits .....  | 38       |
| Speed feedback setting .....  | 39       |
| Alarms.....   | 39       |
| Overload control .....  | 39       |
| Analog inputs 1, 2 and 3 .....  | 39       |
| 5.3.5 Drive tuning.....   | 39       |
| 5.3.5.1 Self tuning of the current regulator .....                          | 39       |
| 5.3.5.1.1 Checking current regulator performance using parameter Eint ..... | 40       |
| 5.3.5.2 Self tuning of the speed regulator .....                            | 40       |
| 5.3.5.3 Field converter .....   | 42       |
| Selection of the functioning system .....                                   | 42       |
| Setting the rated field current.....  | 43       |
| Flux current min/max .....  | 43       |
| 5.3.6 Manual tuning of the regulators .....                                 | 44       |
| Using the Test generator.....   | 44       |
| Manual tuning of speed regulator .....                                      | 44       |
| Manual tuning of field current regulator .....                              | 45       |
| Voltage regulator in the field converter .....                              | 47       |
| 5.3.7 Others tuning .....   | 49       |
| Flux / if curve tuning (Flux / if curve).....                               | 49       |
| Speed-up function.....  | 51       |
| Setting of the speed zero logic.....  | 51       |
| Adaptive of the speed regulator .....                                       | 52       |
| <b>6 - FUNCTION DESCRIPTION.....</b>  | <b>1</b> |
| Functions and parameters .....  | 1        |
| Explanation of parameter tables .....                                       | 2        |
| 6.1 ENABLES.....  | 3        |
| 6.1.1 Enable drive.....   | 4        |
| 6.1.2 Start / Stop.....   | 5        |
| 6.1.3 Fast stop .....   | 6        |
| 6.1.4 Quick Stop .....  | 7        |
| 6.1.5 External fault.....   | 7        |

|   |    |
|---|----|
| 6.2 BASIC START UP MENUS .....  | 8  |
| DRIVE STATUS .....  | 8  |
| START UP .....  | 8  |
| First basic setting .....   | 8  |
| Motor data .....  | 8  |
| Limits .....  | 9  |
| Speed feedback .....  | 9  |
| Alarms .....  | 9  |
| Overload control .....  | 9  |
| Analog inputs .....   | 10 |
| Self tuning of current regulator .....  | 10 |
| Self tuning of speed regulator .....  | 10 |
| Final operation .....   | 11 |
| TUNING .....  | 11 |
| Current self tuning .....   | 11 |
| Speed self tune .....   | 11 |
| Manual tuning of speed regulator, field regulator and voltage regulator ..... | 11 |
| 6.3 MONITOR .....   | 12 |
| 6.4 INPUT VARIABLES .....   | 16 |
| 6.4.1 Ramp ref .....  | 16 |
| 6.4.2 Speed ref .....   | 18 |
| 6.4.3 Torque current reference (T current ref) .....                          | 19 |
| 6.5 LIMITS .....  | 21 |
| 6.5.1 Speed Limits .....  | 21 |
| 6.5.2 Armature current limits (Current limits) .....                          | 22 |
| 6.5.3 Flux limits .....   | 24 |
| 6.6 RAMP .....  | 25 |
| 6.6.1 Acceleration, Deceleration, Quick Stop .....                            | 26 |
| 6.6.2 Ramp shape and control commands .....                                   | 27 |
| 6.7 SPEED REGULATION (SPEED REGULAT) .....                                    | 30 |
| 6.7.1 Speed regulator .....   | 31 |
| 6.7.1.1 Self tuning of Speed regulator .....                                  | 32 |
| 6.7.2 Spd zero logic .....  | 33 |
| 6.7.3 Speed up .....  | 34 |
| 6.7.4 Droop function .....  | 35 |
| 6.7.5 Inertia/Loss compensation .....   | 36 |
| 6.8 CURRENT REGULATION (CURRENT REGULAT) .....                                | 38 |
| 6.9 FLUX REGULATION .....   | 40 |
| 6.10 REG PARAMETERS .....   | 43 |
| 6.11 CONFIGURATION .....  | 45 |
| 6.11.1 Operating mode selection .....   | 45 |
| 6.11.2 Speed base value, Full load current .....                              | 47 |

|   |     |
|---|-----|
| 6.11.3 Configuration of the OK relay (Terminals 35,36) .....                | 47  |
| 6.11.4 To increase the resolution of current limits and references .....    | 48  |
| 6.11.5 Configuration of the speed feedback circuit .....                    | 49  |
| Ind store ctrl parameter [92] .....   | 52  |
| Index storing parameter [13] .....  | 53  |
| 6.11.6 "Standard / American" selection, Software Version .....              | 54  |
| 6.11.7 Dimension factor, Face value fator .....                             | 55  |
| 6.11.8 Programmable alarms .....  | 57  |
| 6.11.9 Address for bus operation .....                                      | 63  |
| 6.11.10 Password .....  | 64  |
| 6.12 I/O CONFIG .....   | 65  |
| 6.12.1 Analog Ouputs .....  | 66  |
| 6.12.2 Analog Inputs .....  | 68  |
| 6.12.3 Digital Outputs .....  | 74  |
| 6.12.4 Digital Inputs .....   | 77  |
| 6.12.5 Speed reference from encoder input (Tach follower function) .....    | 79  |
| 6.13 ADDITIONAL SPEED FUNCTIONS (ADD SPEED FUNCT) .....                     | 81  |
| 6.13.1 Auto capture .....   | 81  |
| 6.13.2 Adptive spd reg .....  | 81  |
| 6.13.3 Speed control .....  | 84  |
| 6.13.4 Speed zero .....   | 85  |
| 6.14 FUNCTIONS .....  | 87  |
| 6.14.1 Motorpotentiometer .....   | 87  |
| 6.14.2 Jog function .....   | 89  |
| 6.14.3 Multi speed function .....   | 91  |
| 6.14.4 Multi ramp function .....  | 94  |
| 6.14.5 Speed Draw function .....  | 98  |
| 6.14.6 Overload control .....   | 100 |
| 6.14.7 Stop control .....   | 121 |
| 6.14.8 Brake control .....  | 123 |
| 6.14.9 Current limitation according to the speed (I/n curve) .....          | 126 |
| 6.15 SPEC FUNCTIONS .....   | 127 |
| 6.15.1 Test generator .....   | 127 |
| 6.15.2 Saving parameters, loading default factory settings, life time ..... | 128 |
| 6.15.3 Failure Register .....   | 128 |
| 6.15.4 Signal adaptation .....  | 129 |
| 6.15.5 Pads .....   | 131 |
| 6.16 OPTIONS .....  | 133 |
| 6.16.1 Option 1 .....   | 133 |
| 6.16.2 Option 2 .....   | 133 |
| 6.16.3 PID Function .....   | 135 |

|  |   |          |
|--|---|----------|
| 6.16.3.1   | General .....                                       | 136      |
| 6.16.3.2   | Inputs / Outputs.....                               | 136      |
| 6.16.3.3   | Feed - Forward .....                                | 137      |
| 6.16.3.4   | PID function .....                                  | 139      |
| 6.16.3.5   | Proportional - integral block .....                 | 141      |
| 6.16.3.6   | Proportional - Derivative control block .....       | 145      |
| 6.16.3.7   | Output reference .....                              | 147      |
| 6.16.3.8   | Function of calculation for Initial diameter .....  | 149      |
| 6.16.3.9   | Procedure of calculation for initial diameter ..... | 151      |
| 6.16.3.10  | Examples of application .....                       | 152      |
| 6.16.3.11  | Generic PID.....                                    | 168      |
| 6.16.3.12  | Application note.....                               | 170      |
| 6.17   | TORQUE WINDER FUNCTION.....                         | 173      |
| 6.17.1   | Diameter calculation .....                          | 174      |
| 6.17.2   | Torque calculation.....                             | 178      |
| 6.17.2.1   | Compensations and closing of the tension loop ..... | 179      |
| 6.17.2.2   | Taper function .....                                | 182      |
| 6.17.3   | Calculation of the speed reference .....            | 183      |
| 6.17.4   | Typical connection diagrams.....                    | 188      |
| 6.17.5   | Control logic.....                                  | 192      |
| Diameter initialization .....                              | 192   |          |
| Initial phase.....   | 192   |          |
| Automatic switching .....                                  | 193   |          |
| Reel stop.....   | 193   |          |
| Jog function.....  | 194   |          |
| 6.17.6   | Application example.....                            | 195      |
| Provisions .....   | 205   |          |
| 1. Drive used as a winder – winding side = up.....         | 205   |          |
| 2. Drive used as a winder – winding side = down .....      | 206   |          |
| 3. Drive used as an unwinder – unwinding side = up.....    | 206   |          |
| 4. Drive used as an unwinder – unwinding side = down ..... | 207   |          |
| 6.17.7   | Block diagram .....                                 | 208      |
| 6.18   | DRIVECOM.....                                       | 212      |
| 6.18.1   | Control word, status word, malfunction code .....   | 212      |
| 6.18.2   | Speed .....   | 213      |
| 6.18.3   | Speed limitation .....                              | 214      |
| 6.18.4   | Acceleration / Deceleration .....                   | 216      |
| 6.18.5   | Factor function .....                               | 218      |
| 6.19   | SERVICE.....  | 218      |
| <b>7-</b>  | <b>MAINTENANCE.....</b>                             | <b>1</b> |
| 7.1  | CARE .....  | 1        |
| 7.2  | SERVICE.....  | 1        |
| 7.3  | REPAIRS.....  | 1        |



|   |          |
|---|----------|
| 7.4 CUSTOMER SERVICE .....                                    | 1        |
| <b>8 - TROUBLESHOOTING .....</b>                              | <b>1</b> |
| Failure alarms in the keypad display .....                    | 1        |
| Other faults .....  | 4        |
| <b>9 - BLOCK DIAGRAM .....</b>                                | <b>1</b> |
| 9.1 CONTROL BLOCK DIAGRAMS .....                              | 1        |
| TPD32 Converter Overview .....                                | 1        |
| Digital Inputs /Outputs & Mapping Standard and TBO cards..... | 2        |
| Analog Inputs/Outputs & Mapping .....                         | 3        |
| Speed Reference Generation .....                              | 4        |
| Ramp reference Block .....                                    | 5        |
| Speed / Current Regulator Overview .....                      | 6        |
| Speed Feedback setting .....                                  | 7        |
| Speed regulator .....   | 8        |
| Speed regulator PI part.....                                  | 9        |
| Speed adaptive and Speed zero logic .....                     | 10       |
| Current regulator .....                                       | 11       |
| Field current regulator.....                                  | 12       |
| Motor parameters.....   | 13       |
| Start and Stop management.....                                | 14       |
| Droop compensation.....                                       | 15       |
| Inertia / Loss compensation.....                              | 16       |
| Speed Threshold / Speed control .....                         | 17       |
| PID function .....  | 18       |
| Functions .....   | 19       |
| LINKS Function.....   | 20       |
| PAD parameters.....   | 21       |
| Taper Current Limits.....                                     | 22       |
| Dimension factor - Face value factor .....                    | 23       |
| Test Generator .....  | 24       |
| JOG function.....   | 25       |
| Multispeed.....   | 26       |
| Motor potentiometer .....                                     | 27       |
| Alarm mapping.....  | 28       |
| 9.2 POWER CIRCUIT BLOCK DIAGRAMS.....                         | 29       |
| 9.3 REGULATION CARD .....                                     | 35       |
| <b>10 - PARAMETER LISTS .....</b>                             | <b>1</b> |
| 10.1 COMPLETE MAIN MENU LIST .....                            | 1        |
| 10.2 NUMERICAL LIST.....                                      | 37       |
| 10.3 PARAMETERS IN ALPHABETICAL ORDER.....                    | 63       |

|   |          |
|---|----------|
| 10.4 LIST OF HIGH PRIORITY PARAMETERS .....                       | 79       |
| <b>11 - REPLACEMENT PARTS .....</b>                               | <b>1</b> |
| 11.1 HARDWARE CONFIGURATION (CARDS / DIP SWITCHES / JUMPERS)..... | 1        |
| 11.2 R-TPD32 REGULATION CARD .....                                | 2        |
| 11.3 FIR1-... POWER/DRIVER CARDS.....                             | 3        |
| 11.4 FIR2-... POWER/DRIVER CARD .....                             | 4        |
| 11.5 FIR3-32 POWER/DRIVER CARD .....                              | 5        |
| 11.6 PBB POWER CONNECTION CARD .....                              | 6        |
| 11.7 PFC1-32 FIELD CONVERTER .....                                | 6        |
| 11.8 PFC2-31 FIELD CONVERTER .....                                | 7        |
| 11.9 SN-FC FIELD SNUBBER.....                                     | 7        |
| 11.10 SN5-31 SNUBBER .....  | 8        |
| 11.11 SW1-31 POWER SUPPLY CARD .....                              | 8        |
| 11.12 SW2-32 POWER SUPPLY CARD .....                              | 9        |
| 11.13 FL-31 FILTER CARD.....                                      | 9        |
| 11.14 CN3 CONNECTION CARD .....                                   | 10       |
| 11.15 I/O OPTION CARD TBO .....                                   | 10       |

# LIST OF FIGURES

|   |          |
|---|----------|
| <b>1 - SAFETY PRECAUTIONS - PRECAUTIONS DE SECURITÉ</b> .....   | <b>1</b> |
| <b>2 - DESCRIPTION, COMPONENT IDENTIFICATION AND SPECIFICATIONS</b> .....   | <b>1</b> |
| <i>Fig 2.1: Base diagram of a converter</i> .....   | 1        |
| <i>Fig. 2.5.1: Drive dimensions for 20 A ... 70 A sizes (form 1)</i> .....  | 14       |
| <i>Fig. 2.5.2: Drive dimensions for 110 A ... 185 A sizes (form 1)</i> .....  | 15       |
| <i>Fig. 2.5.3: Drive dimensions for 280 A ... 420 A sizes (form 2)</i> .....  | 16       |
| <i>Fig. 2.5.4: Drive dimensions for 500 A ... 650 A sizes (form 2)</i> .....  | 17       |
| <i>Fig. 2.5.5: Drive dimensions for 770 A ... 1050 A sizes (form 3)</i> .....   | 18       |
| <b>3 - INSTALLATION GUIDELINES</b> .....  | <b>1</b> |
| <i>Figure 3.3.1: max Angle of Inclination</i> .....   | 2        |
| <i>Figure 3.3.2: Mounting Clearance</i> .....   | 3        |
| <b>4 - WIRING PROCEDURES</b> .....  | <b>1</b> |
| <i>Figure 4.1.1: Removing the Front Panel</i> .....   | 1        |
| <i>Figure 4.4.1: R-TPD32 regulation card</i> .....  | 6        |
| <i>Figure 4.4.2: Disposition of terminals from 1 to 42</i> .....  | 9        |
| <i>Figure 4.5.1.1: RS485 serial interface</i> .....   | 12       |
| <i>Figure 4.6.2.1: Installing the option card</i> .....   | 15       |
| <i>Figure 4.7.1.1: DEII card</i> .....  | 16       |
| <i>Figure 4.8.1:Control sequencing</i> .....  | 18       |
| <i>Figure 4.8.3: Typical connections</i> .....  | 19       |
| <i>Figure 4.8.4: Encoder and Tachometer Connections</i> .....   | 20       |
| <i>Figure 4.8.5: Programmable Inputs/outputs with relay and contacts</i> .....  | 20       |
| <i>Figure 4.8.6: Programmable Inputs/outputs with PLC</i> .....   | 21       |
| <i>Figure 4.8.7: DEII connection</i> .....  | 21       |
| <i>Figure 4.9.1.1: Position of the super fast fuses</i> .....   | 22       |
| <i>Figure 4.11.1: Potentials of the regulator section</i> .....   | 31       |
| <b>5 - CONVERTER OPERATION</b> .....  | <b>1</b> |
| <i>Figure 5.1.2.1: Moving inside a menu</i> .....   | 2        |
| <i>Figure 5.3.6.1: Above: Actual spd; Below: Motor current. Speed P too low.</i> .....  | 45       |
| <i>Figure 5.3.6.3: Above: Actual spd; Below: Motor current. Speed I too high.</i> .....   | 45       |
| <i>Figure 5.3.6.2: Above: Actual spd; Below: Motor current. Speed P too high.</i> .....   | 45       |
| <i>Figure 5.3.6.4: Above: Actual spd; Below: Motor current. Speed P and Speed I set correctly.</i> .....  | 45       |
| <i>Figure 5.3.6.5: Above: Flux reference; Below: Flux current. The regulator behavior is not good. Jumps are due to field changing.</i> .....   | 46       |
| <i>Figure 5.3.6.7: Above: Flux reference; Below: Flux current. The increment in the field current has no jump. Variation compared to Fig. 4.5.7: Increase of Flux P from 2 to 10%. Flux I = 5%.</i> ..... | 46       |
| <i>Figure 5.3.6.6: Above: Flux reference; Below: Flux current. The reduction of the field current depends on the field time constant. The reg has no influence.</i> .....                                 | 46       |
| <i>Figure 5.3.6.8: Above: Flux; Below: Output voltage. After a speed change the field current (Flux) has some jumps. Voltage P = 10%, Voltage I = 80%.</i> .....  | 48       |
| <i>Figure 5.3.6.10: Above: Flux; Below: Output voltage. After a short transient, the field current and armature voltage are constant. Voltage P = 40%, Voltage I = 50%.</i> .....                         | 48       |
| <i>Figure 5.3.6.9: Above: Flux; Below: Output voltage. The gain is too low. The armature voltage increases. Voltage P = 3%, Voltage I = 5%.</i> .....   | 48       |
| <i>Figure 5.3.7.1: Curve convection flux/current</i> .....  | 49       |
| <i>Figure 5.3.7.2: Blocks diagrams of field current regulator</i> .....   | 50       |
| <i>Figure 5.3.7.3: Above: Actual spd; Below: Motor current jumps with the speed changes due to a high moment of inertia. The function Speed-up is not active.</i> .....                                   | 51       |
| <i>Figure 5.3.7.4: Above: Actual spd; Below: Motor current. The same drive with Speed -up function active.</i> .....  | 51       |

|  |          |
|--|----------|
| <b>6 - FUNCTION DESCRIPTION.....</b>   | <b>1</b> |
| Figure 6.1.1 Enables via potential free contacts and PLC.....                  | 3        |
| Figure 6.4.1.1: Ramp references.....   | 17       |
| Figure 6.4.2.1: Speed reference.....   | 18       |
| Figure 6.4.3.1: Torque current reference.....                                  | 19       |
| Figure 6.5.2.1: Torque limits with <b>T curr lim type</b> = T lim +/-.....     | 23       |
| Figure 6.5.2.2: Torque limits with <b>T curr lim type</b> = T lim mot/gen..... | 23       |
| Figure 6.6.1 : Ramp circuit.....   | 25       |
| Figure 6.6.1.1: Accel, decel and Quick stop.....                               | 26       |
| Figure 6.6.2.1: Ramp shape.....  | 28       |
| Figure 6.6.2.2: Ramp delay.....  | 28       |
| Figure 6.6.2.3: Ramp control.....  | 29       |
| Figure 6.7.1: Speed regulation.....  | 30       |
| Figure 6.7.2.1: Speed zero logic.....  | 33       |
| Figure 6.7.4.1: Droop compensation.....  | 35       |
| Figure 6.7.4.2: Droop function example.....                                    | 36       |
| Figure 6.7.5.1: Inertia/Loss compensation.....                                 | 36       |
| Figure 6.8.1: Torque current regulaton.....                                    | 38       |
| Figure 6.9.1: Motor control.....   | 40       |
| Figure 6.11.5.1: Speed feedback.....   | 50       |
| Figure 6.11.5.2: Allowed area for Encoder 2 pulses and Motor max speed.....    | 51       |
| Figure 6.11.7.1: Calculation using dimension and face value factors.....       | 55       |
| Figure 6.11.8.1: Drive enabling sequence: <b>Main command</b> = Terminals..... | 62       |
| Figure 6.11.8.2 Drive enable sequence: <b>Main command</b> = Digital.....      | 62       |
| Figure 6.12.1: Arrangement of the programmable I/O.....                        | 65       |
| Figure 6.12.1.1: Option card, analog output blocks.....                        | 67       |
| Figure 6.12.2.1: Analog input.....   | 72       |
| Figure 6.12.2.2: Analog Input 1 window comparator.....                         | 72       |
| Figure 6.12.3.1: Digital outputs.....  | 75       |
| Figure 6.12.4.1: Digital inputs.....   | 77       |
| Figure 6.12.5.1: Tach follower.....  | 79       |
| Figure 6.12.5.2: Example of application of the encoder reference.....          | 80       |
| Figure 6.13.2.1: Adaptive of the speed regulator.....                          | 83       |
| Figure 6.13.3.1: "Speed threshold" (up) and "Set speed" (down) messages.....   | 85       |
| Figure 6.13.4.1: Speed zero.....   | 86       |
| Figure 6.14.1.1: Motor potentiometer.....                                      | 88       |
| Figure 6.14.2.1: Example of external activation in Jog mode.....               | 90       |
| Figure 6.14.3.1: Selection of different references via terminals.....          | 91       |
| Figure 6.14.3.2: Multi speed function.....                                     | 93       |
| Figure 6.14.4.1: Multi ramp selection via terminals.....                       | 97       |
| Figure 6.14.4.2: Multi ramp selection via signals.....                         | 97       |
| Figure 6.14.5.1: Speed draw block diagram.....                                 | 98       |
| Figure 6.14.5.2: Rubber calender example.....                                  | 99       |
| Figure 6.14.6.1: Overload control (Overload mode = curr limited).....          | 103      |
| Figure 6.14.6.2: Overload control (Overload mode = curr not limited).....      | 103      |
| Figure 6.14.6.3: Example- Operating point of drive.....                        | 120      |
| Figure 6.14.7.1: Start and stop management.....                                | 121      |
| Figure 6.14.8.1: Diagram of control.....                                       | 124      |
| Figure 6.14.8.2: Brake control diagram.....                                    | 125      |
| Figure 6.14.9.1 Current limitation according to the speed.....                 | 126      |
| Figure 6.15.1.1: Test generator output.....                                    | 127      |
| Figure 6.15.4.1: Structure of the signal adaptation.....                       | 130      |
| Figure 6.15.5.1: Bus pads.....   | 132      |
| Figure 6.16.3.1: Feed-forward block description.....                           | 137      |
| Figure 6.16.3.2: PID blocks description.....                                   | 139      |

|   |          |
|---|----------|
| Figure 6.16.3.3: PI block description.....  | 141      |
| Figure 6.16.3.4: PD block description .....   | 145      |
| Figure 6.16.3.5: Output reference block description .....                                     | 147      |
| Figure 6.16.3.6: Diameter calculation block description .....                                 | 149      |
| Figure 6.16.3.7: Diameter calculation .....   | 150      |
| Figure 6.16.3.8: Nip-roll control with dancer .....   | 152      |
| Figure 6.16.3.9: Nip-rolls control with load cell .....                                       | 155      |
| Figure 6.16.3.10: Winder/Unwinder control with dancer .....                                   | 158      |
| Figure 6.16.3.11: Diameter calculation .....  | 162      |
| Figure 6.16.3.12: Winder/unwinder control with sensor diameter .....                          | 163      |
| Figure 6.16.3.13: Relation between transducer signal and coil signal .....                    | 163      |
| Figure 6.16.3.14: Pressure control for pumps and extruder .....                               | 165      |
| Figure 6.16.3.15: Example with small and large diameter.....                                  | 170      |
| Figure 6.16.3.16: Relation between PI I gain PID and PI I output PID.....                     | 171      |
| Figure 6.16.3.17: General description of the PID blocks .....                                 | 172      |
| Figure 6.17.1: Acceleration and deceleration indication .....                                 | 180      |
| Figure 6.17.2: Relation among the Taper function parameters .....                             | 182      |
| Figure 6.17.3: Operative sequence of the functioning status.....                              | 185      |
| Figure 6.17.4: Functioning with Jog TW enable.....  | 187      |
| Figure 6.17.5: Winder with an automatic switch and a closed loop tension regulation.....      | 188      |
| Figure 6.17.6: Winder with an automatic switch and a closed loop tension regulation.....      | 189      |
| Figure 6.17.7: Winder with an automatic switch and a closed loop tension regulation.....      | 190      |
| Figure 6.17.8: Winder with an automatic switch and a closed loop tension regulation.....      | 191      |
| Figure 6.17.9: Initial phase with a stopped line .....  | 192      |
| Figure 6.17.10: Automatic switching between two coils during a winding/unwinding period ..... | 193      |
| Figure 6.17.11: Coil stop after the automatic switching.....                                  | 194      |
| Figure 6.17.12: Jog function to prepare the machine.....                                      | 194      |
| Figure 6.17.13: Drive used as a winder – winding side = up.....                               | 205      |
| Figure 6.17.14: Drive used as a winder – winding side = down .....                            | 206      |
| Figure 6.17.15: Drive used as an unwinder – unwinding side = up .....                         | 206      |
| Figure 6.17.16: Drive used as an unwinder – unwinding side = down .....                       | 207      |
| Figure 6.17.4.1: Acceleration and deceleration.....   | 216      |
| <b>7- MAINTENANCE.....</b>  | <b>1</b> |
| <b>8 - TROUBLESHOOTING .....</b>  | <b>1</b> |
| <b>9 - BLOCK DIAGRAM.....</b>   | <b>1</b> |
| <b>10 - PARAMETER LISTS .....</b>   | <b>1</b> |
| <b>11 - REPLACEMENT PARTS .....</b>   | <b>1</b> |

# LIST OF TABLES

|  |          |
|--|----------|
| <b>1 - SAFETY PRECAUTIONS - PRECAUTIONS DE SECURITÉ</b> .....                                | <b>1</b> |
| <b>2 - DESCRIPTION, COMPONENT IDENTIFICATION AND SPECIFICATIONS</b> .....                    | <b>1</b> |
| Table 2.1.1: Converter size.....   | 2        |
| Table 2.3.1: Keypad LEDs .....   | 7        |
| Table 2.4.2.1: AC input voltages .....   | 8        |
| Table 2.4.2.2: AC input currents.....  | 9        |
| Table 2.4.3.1: Output currents.....  | 10       |
| Table 2.4.3.2: Field current resistors.....  | 11       |
| Table 2.4.3.3: Armature circuit output voltages.....   | 11       |
| Table 2.4.3.4: Field circuit output voltages.....  | 11       |
| Table 2.6.1: Power Dissipation.....  | 19       |
| <b>3 - INSTALLATION GUIDELINES</b> .....   | <b>1</b> |
| <b>4 - WIRING PROCEDURES</b> .....   | <b>1</b> |
| Table 4.3.1: Terminals description.....  | 2        |
| Table 4.3.2: Cable size for power terminals U, V, W, C, D, PE .....                          | 2        |
| Table 4.3.3: Cable section for UL approval.....  | 2        |
| Table 4.3.4: Wire adapter Kit and lugs suggested for UL approval.....                        | 4        |
| Table 4.3.5: Cable size for power field terminals U1, V1, C1, D1.....                        | 4        |
| Table 4.3.6: Cable size for fans, signals, thermistors and regulation supply.....            | 5        |
| Table 4.4.1: LEDs on the R-TPD32 card.....   | 6        |
| Table 4.4.2: Dip-switch S15 adaptation of the regulation card to the device type.....        | 7        |
| Table 4.4.3 : Dip-switch S4 adaptation of the tachometer feedback to the input voltage ..... | 8        |
| Table 4.4.4: Jumpers on the R-TPD32 card.....  | 8        |
| Table 4.4.5: Test points on Regulator card.....  | 8        |
| Table 4.4.6 - A: Terminal Assignment (terminals from 1 to 20).....                           | 9        |
| Table 4.4.6 - B: Terminal Assignment (terminals from 21 to 42).....                          | 10       |
| Table 4.4.7: Cable size for fans, signals, and thermistors.....                              | 11       |
| Table 4.4.8: Terminal strip for the connection of an analog tachometer .....                 | 11       |
| Table 4.4.9: Assignment of an XE1 connector for a sinusoidal encoder .....                   | 11       |
| Table 4.4.10: Assignment of the XE2 connector for a digital encoder.....                     | 11       |
| Table 4.5.2.1: Description of the XS connector for the RS485 serial interface.....           | 13       |
| Table 4.6.1.1: Terminal strip connections.....   | 14       |
| Table 4.6.1.2: Cable size for terminals of the option card TBO .....                         | 15       |
| Table 4.7.2.1: Terminal assignment (Terminals 0Venc and +Venc).....                          | 17       |
| Table 4.7.2.2: Permissible cable cross section on the terminals of option card DEIL.....     | 17       |
| Table 4.7.2.3: XS1 9-pole connector .....  | 17       |
| Table 4.9.1.1: Recommended fuses (externally mounted).....                                   | 23       |
| Table 4.9.2.1: Overload fuses.....   | 25       |
| Table 4.9.3.1: Internal fuses.....   | 26       |
| Table 4.9.5: Control power protection.....   | 27       |
| Table 4.10.1.1: AC input choke .....   | 29       |
| <b>5 - CONVERTER OPERATION</b> .....   | <b>1</b> |
| Table 5.1.1.1: Diagnostic LEDs.....  | 1        |
| Table 5.3.5.3.1: Tuning resistances of the field current.....                                | 43       |
| <b>6 - FUNCTION DESCRIPTION</b> .....  | <b>1</b> |
| Table 6.14.2.1: Multi speed function.....  | 93       |
| Table 6.14.4.1: Ramp selection.....  | 96       |
| Table 6.14.6.1: I2t derating.....  | 102      |

|   |          |
|---|----------|
| <b>7- MAINTENANCE</b> .....   | <b>1</b> |
| <b>8 - TROUBLESHOOTING</b> .....  | <b>1</b> |
| <b>9 - BLOCK DIAGRAM</b> .....  | <b>1</b> |
| <b>10 - PARAMETER LISTS</b> .....   | <b>1</b> |
| <b>11 - REPLACEMENT PARTS</b> .....   | <b>1</b> |
| <i>Table 11.3.1: Selection of dip-switches "S3-XX" and "S4-XX" for FIR1-... cards (Rev. index &gt; "q")</i> ..... | <i>3</i> |
| <i>Table 11.4.1: Selection of dip-switches "S3-XX" and "S4-XX" for FIR2-X-... cards (Rev. index ≥ "n")</i> .....  | <i>4</i> |
| <i>Table 11.5.1: Selection of dip-switches "S3-XX" and "S4-XX" for FIR3-32- cards. (Rev. index ≥ "m")</i> .....   | <i>5</i> |

## SAFETY SYMBOL LEGEND

- Warning:** Commands attention to an operating procedure, practice, condition, or statement which, if not strictly observed, could result in personal injury or death.
- Caution:** Commands attention to an operating procedure, practice, condition, or statement which, if not strictly observed, could result in damage or destruction of equipment.
- Note:** Commands attention to an operating procedure, practice, condition, or statement that must be highlighted.

## BLOCK DIAGRAM LEGEND

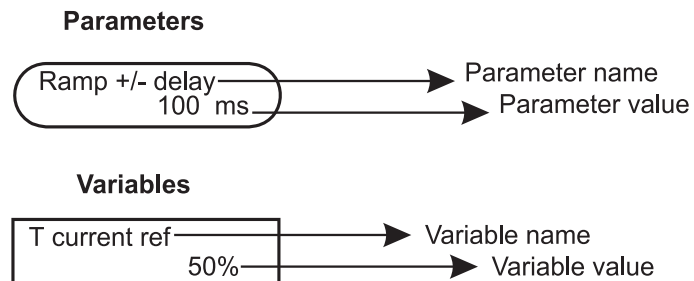



# 1 - SAFETY PRECAUTIONS - PRECAUTIONS DE SECURITÉ

## **ATTENTION!**

According to the EEC standards the TPD32 and accessories must be used only after checking that the machine has been produced using those safety devices required by the 89/392/EEC set of rules, as far as the machine industry is concerned.

Drive systems cause mechanical motion. It is the responsibility of the user to insure that any such motion does not result in an unsafe condition. Factory provided interlocks and operating limits should not be bypassed or modified.

*Selon les normes EEC, les drives TPD32 et leurs accessoires doivent être employés seulement après avoir vérifié que la machine ait été produite avec les mêmes dispositifs de sécurité demandés par la réglementation 89/392/EEC concernant le secteur de l'industrie.*

*Les systèmes provoquent des mouvements mécaniques. L'utilisateur est responsable de la sécurité concernant les mouvements mécaniques. Les dispositifs de sécurité prévues par l'usine et les limitations opérationnelles ne doivent être dépassés ou modifiés.*

## **WARNING - ELECTRICAL SHOCK AND BURN HAZARD / ATTENTION – DÉCHARGE ÉLECTRIQUE ET RISQUE DE BRÛLURE :**

When using instruments such as oscilloscopes to work on live equipment, the oscilloscope's chassis should be grounded and a differential amplifier input should be used. Care should be used in the selection of probes and leads and in the adjustment of the oscilloscope so that accurate readings may be made. See instrument manufacturer's instruction book for proper operation and adjustments to the instrument.

*Lors de l'utilisation d'instruments (par exemple oscilloscope) sur des systèmes en marche, le châssis de l'oscilloscope doit être relié à la terre et un amplificateur différentiel devrait être utilisé en entrée.*

*Les sondes et conducteurs doivent être choisis avec soin pour effectuer les meilleures mesures à l'aide d'un oscilloscope.*

*Voir le manuel d'instruction pour une utilisation correcte des instruments.*

## **WARNING - FIRE AND EXPLOSION HAZARD / ATTENTION – RISQUE D'INCENDIES ET D'EXPLOSIONS:**

Fires or explosions might result from mounting Drives in hazardous areas such as locations where flammable or combustible vapors or dusts are present. Drives should be installed away from hazardous areas, even if used with motors suitable for use in these locations.

*L'utilisation des drives dans des zones à risques (présence de vapeurs ou de poussières inflammables), peut provoquer des incendies ou des explosions. Les drives doivent être installés loin des zones dangereuses, et équipés de moteurs appropriés.*

## **WARNING - STRAIN HAZARD / ATTENTION À L'ÉLÉVATION:**

Improper lifting practices can cause serious or fatal injury. Lift only with adequate equipment and trained personnel.

*Une élévation inappropriée peut causer des dommages sérieux ou fatals. Il doit être élevé seulement avec des moyens appropriés et par du personnel qualifié.*

## **WARNING - DANGER OF ELECTIC SHOCK / ATTENTION – CAS DE DECHARGE ELECTRIQUE:**

Drives and motors must be ground connected according to the NEC (national electric rules).

*Tous les moteurs et les drives doivent être mis à la terre selon le Code Electrique National ou équivalent.*

## **WARNING / ATTENTION:**

Replace all covers before applying power to the Drive. Failure to do so may result in death or serious injury.

*Remettre tous les capots avant de mettre sous tension le drive. Des erreurs peuvent provoquer de sérieux accidents ou même la mort.*

## **WARNING / ATTENTION:**

Converters are electrical appliances for use in heavy current installations. Parts of the converter are energized during operation. The electrical installation and the opening of the device should therefore only be carried out by qualified personnel. Improper installation of motors or converters may therefore cause the failure of the device as well as serious injury to people or material damage. Follow the instructions given in this manual and observe the local and national safety regulations applicable.

*Les convertisseurs sont des dispositifs électriques utilisés dans des installations industriels. Une partie des drives sont sous tension pendant l'opération. L'installation électrique et l'ouverture des drives devrait être exécuté uniquement par du personnel qualifié. De mauvaises installations de moteurs ou de drives peuvent provoquer des dommages matériels ou blesser des personnes. On doit suivre les instructions données dans ce manuel et observer les règles nationales de sécurité.*

## **WARNING! - POWER SUPPLY AND GROUNDING / ATTENTION ! ALIMENTATION PUISSANCE ET MISE À LA TERRE**

In case of a three phase supply not symmetrical to ground, an insulation loss of one of the devices connected to the same network can cause functional problem to the drive, if the use of a wye/delta transformer is avoided.

- 1 The drives are designed to be powered from standard three phase lines that are electrically symmetrical with respect to ground (TN or TT network).
- 2 In case of supply with IT network, the use of delta/star transformer is mandatory, with a secondary three phase wiring referred to ground.

Please refer to the following connection sample.

*Si le réseau n'est pas équilibré par rapport à la terre et qu'il n'y a pas de transformateur raingle/étoile, une mauvaise isolation d'un appareil électrique connecté au même réseau que le variateur peut lui causer des troubles de fonctionnement.*

- 1 *Les variateurs sont prévus pour être alimentés par un réseau triphasé équilibré avec un régime de neutre standard (TN ou TT).*
- 2 *Si le régime de neutre est IT, nous vous recommandons d'utiliser un transformateur triangle/étoile avec point milieu ramené à la terre*

*Vous pouvez trouver ci-après des exemples de câblage.*

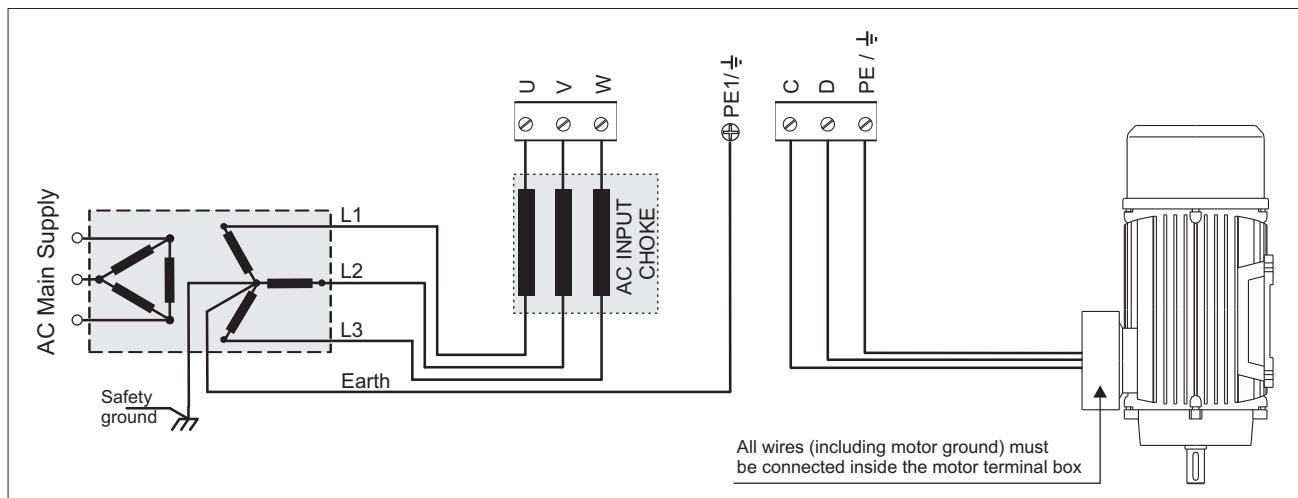

### **CAUTION / PRECAUTION:**

Do not connect power supply voltage that exceeds the standard specification voltage fluctuation permissible. If excessive voltage is applied to the Drive, damage to the internal components will result.

*Ne pas raccorder de tension d'alimentation dépassant la fluctuation de tension permise par les normes. Dans le cas d'une alimentation en tension excessive, des composants internes peuvent être endommagés.*

### **CAUTION / PRECAUTION:**

Do not operate the Drive without the ground wire connected. The motor chassis should be grounded to earth through a ground lead separate from all other equipment ground leads to prevent noise coupling.

The grounding cable shall be sized in accordance with the national electric rules and it is to be fixed using the crimp tool specified by the cable manufacturer.

*Ne pas faire fonctionner le drive sans prise de terre. Le châssis du moteur doit être mis à la terre à l'aide d'un connecteur de terre séparé des autres pour éviter le couplage des perturbations.*

*Le câble de terre devrait être dimensionné selon la norme électrique nationale et doit être fixé à l'aide d'un instrument de serrage spécifié par le producteur du câble.*

### **CAUTION / PRECAUTION:**

Do not perform a megger test between the Drive terminals or on the control circuit terminals.

*Ne pas exécuter un test megger entre les bornes du drive ou entre les bornes du circuit de contrôle.*

**CAUTION / PRECAUTION:**

Because the ambient temperature greatly affects Drive life and reliability, do not install the Drive in any location that exceeds the allowable temperature. Leave the ventilation cover attached for temperatures of 104° F (40° C) or below.

*Étant donné que la température ambiante influe sur la vie et la fiabilité du drive, on ne devrait pas installer le drive dans des places où la température permise est dépassée. Laisser le capot de ventilation en place pour températures de 104°F (40°C) ou inférieures.*

**CAUTION / PRECAUTION:**

If the Drive's Fault Alarm is activated, consult the TROUBLESHOOTING section of this instruction book, and after correcting the problem, resume operation. Do not reset the alarm automatically by external sequence, etc.

*Si la Fault Alarm du drive est activée, consulter la section du manuel concernant les défauts et après avoir corrigé l'erreur, reprendre l'opération. Ne pas réinitialiser l'alarme automatiquement par une séquence externe, etc....*

**CAUTION / PRECAUTION:**

Be sure to remove the desiccant dryer packet(s) when unpacking the Drive. (If not removed these packets may become lodged in the fan or air passages and cause the Drive to overheat).

*Lors du déballage du drive, retirer le sachet déshydraté. (Si celui-ci n'est pas retiré, il empêche la ventilation et provoque une surchauffe du drive).*

**CAUTION / PRECAUTION:**

The Drive must be mounted on a wall that is constructed of heat resistant material. While the Drive is operating, the temperature of the Drive's cooling fins can rise to a temperature of 194° F (90° C).

*Le drive doit être monté sur un mur construit avec des matériaux résistants à la chaleur. Pendant le fonctionnement du drive, la température des ailettes du dissipateur thermique peut arriver à 194°F (90°).*

**Note:**

The terms "Converters", "Controller" and "Drive" are sometimes used interchangeably throughout the industry. We will use the term "Drive" in this document

*Les mots "Convertisseur", "Controller" et "Drive" sont interchangeables dans le domaine industriel. Nous utiliserons dans ce manuel seulement le mot "Drive".*

1. Never open the device or covers while the AC Input power supply is switched on. Wait for at least one minute before working on the terminals or inside the device.

*Ne jamais ouvrir l'appareil lorsqu'il est sous tension. Le temps minimum d'attente avant de pouvoir travailler sur les bornes ou bien à l'intérieur de l'drive est de 1 minute.*

2. Do not touch or damage any components when handling the device. The changing of the isolation gaps or the removing of the isolation and covers is not permissible. If the front plate has to be removed because of a room temperature higher than 40 degrees, the user has to ensure that no occasional contact with live parts may occur.

*Manipuler l'appareil de façon à ne pas toucher ou endommager des parties. Il n'est pas permis de changer les distances d'isolement ou bien d'enlever des matériaux isolants ou des capots. Si la plaque frontale doit être enlevée pour un fonctionnement avec la température de l'environnement plus haute que 40°C, l'utilisateur doit s'assurer, par des moyens opportuns, qu'aucun contact occasionnel ne puisse arriver avec les parties sous tension.*

3. Protect the device from impermissible environmental conditions (temperature, humidity, shock etc.)

*Protéger l'appareil contre des effets extérieurs non permis (température, humidité, chocs etc.).*

4. No voltage should be connected to the output of the converter (terminals C and D). The parallel connection of several motors on a converter output is not permissible.

*Aucune tension à la sortie du convertisseur ne peut être appliquée (bornes C et D). Il n'est pas permis d'insérer plus de convertisseurs en parallèle à la sortie ni d'effectuer une connexion directe de l'entrée avec une sortie du convertisseur.*

5. When engaging a running motor, the Auto capture function (Auto capture in the ADD SPEED FUNCT menu) must be activated.

*Pour reprendre des moteurs en rotation, la fonction suivante doit être activée : "Auto capture" dans le menu ADD SPEED FUNCT.*

6. A capacitive load (e.g. phase compensation capacitors) should not be connected to the output of the frequency inverter (terminals C and D).  
*Aucune charge capacitive ne doit être connectée à la sortie du convertisseur (bornes C et D) (par exemple des condensateurs de mise en phase).*
7. Always connect the converter to the protective ground (PE) via the marked connection terminals and the housing. The discharge current to earth ground is greater than 3.5 mA. EN 50178 specifies that with discharge currents greater than 3.5 mA the protective conductor ground connection must be fixed type and doubled for redundancy.  
*Effectuer toujours des connexions de terre (PE) par le biais des bornes et du châssis. Le courant de dispersion vers la terre est supérieur à 3,5 mA. Selon EN 50178 il faut prévoir dans ces cas une double connexion à terre.*
8. The electrical commissioning should only be carried out by qualified personnel, who are also responsible for the provision of a suitable ground connection and a protected power supply feeder in accordance with the local and national regulations. The motor must be protected against overloads.  
*La mise en service électrique doit être effectuée par un personnel qualifié. Ce dernier est responsable de l'existence d'une connexion de terre adéquate et d'une protection des câbles d'alimentation selon les prescriptions locales et nationales. Le moteur doit être protégé contre la surcharge*
9. No dielectric tests should be carried out on parts of the frequency inverter. A suitable measuring instrument (internal resistance of at least 10 k $\Omega$ /V) should be used for measuring the signal voltages.  
*Il ne faut pas exécuter de tests de rigidité diélectrique sur des parties du convertisseurs. Pour mesurer les tensions, des signaux, il faut utiliser des instruments de mesure appropriés (résistance interne minimale 10 k $\Omega$ /V).*
10. When the drive is stopped, but it has not been disconnected from the main via the main contactor, it is not possible to exclude the accidental movement of the motor shaft when a failure occurs.  
*Quand l'actionnement est arrêté, mais non débranché du réseau par le contacteur de réseau, il n'est pas possible d'exclure le mouvement accidentel de l'arbre moteur en cas de panne.*
11. The user must provide overload protection for the motor, as indicated in chapter 2.7.1 and Fig. 4.8.2.  
*L'utilisateur doit effectuer la protection de surcharge du moteur, comme indiqué dans le chapitre 2.7.1 et figure 4.8.2.*

**WARNING / ATTENTION:**

The UL listed equipments is suitable for use on a circuit capable of delivering not more than the rms symmetrical amperes, 500 volts maximum, shown in the table below, when protected by special purpose fuses JFHR2, Gould or Bussman, Model n. as in table 4.9.1.1 and 4.9.2.1. Fuses are internally mounted on sizes 770...1050A.

*Cet appareil est apte pour l'utilisation sur un circuit à même de délivrer un courant rms symétrique de court-circuit, à un max. de 500 volt, pas supérieur aux valeurs ci-dessus.*

| Converter size                 | Short circuit current |
|--------------------------------|-----------------------|
| 17 ... 850 A (American sizes)  | 100 kA                |
| 20 ... 1050 A (European sizes) | 100 kA                |

## 2 - DESCRIPTION, COMPONENT IDENTIFICATION AND SPECIFICATIONS

### 2.1 GENERAL

A converter transforms the constant voltage of an existing three-phase power supply into a direct voltage, in order to regulate the speed and/or the torque of a direct current motor with a separate excitation.

The available TPD32 converters are of two types:

TPD32...2B for a two quadrant functioning

TPD32...4B for a four quadrant functioning

The default version of a converter includes the presence of a power supply circuit for the adjustable field; in this way the motors can operate with a mixed armature or field regulation, without adding other devices.

Each type includes three series of devices, which differ the one from the other because of the max. power supply voltage:

TPD32-400/...; AC input supply voltage up to 400 V, 3Ph

TPD32-500/...; AC input supply voltage up to 500 V, 3Ph

TPD32-690/...; AC input supply voltage up to 690 V, 3Ph

The basic technical data of a converter are stated in the type code and on the identification nameplate..

Example: **TPD32-400/470-280-2B**

SIEIDriveTPD32 converter, three phase supply

400 Mains voltage  $U_{LN}$  in Volt

470 Rated armature voltage  $U_{dN}$  in Volt

280 Rated armature current  $I_{dN}$  in Ampere

2B Functioning 2B = two quadrant

4B = four quadrant

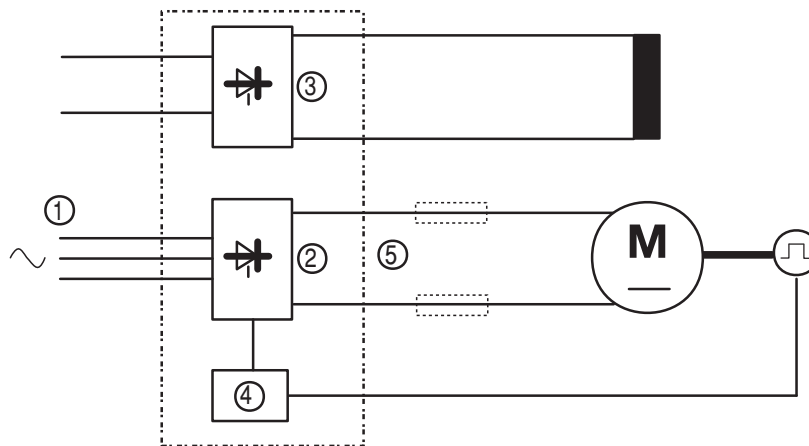

Fig 2.1: Base diagram of a converter

① AC input supply voltage: 230 V, 3Ph, 50/60 Hz  
 400 V, 3Ph, 50/60 Hz  
 460 V, 3Ph, 50/60 Hz  
 500 V, 3Ph, 50/60 Hz  
 690 V, 3Ph, 50/60 Hz

- ② Armature converter: Totally controlled three-phase bridge. It converts the alternating voltage into a direct voltage. (Double bridge for TPD32...4B...)
- ③ Field converter: Semi-controlled single-phase bridge
- ④ Programmable control section: Control and regulation cards of the power section. Commands, references and feedbacks are connected to them.
- ⑤ Output voltage : Direct voltage changing from 0 to  $U_{dN}$
- Output rated current: 20.... 3300 A [for a max. ambient temperature of 104°F (40°C)]

The basic technical data of a converter are stated in the type code and on the identification nameplate.

The converters of TPD32 series are available in the following versions:

- TPD32-400/420-...-4B** Four quadrant converter for AC input voltage up to 400 V
- TPD32-400/470-...-2B** Two quadrant converter for AC input voltage up to 400 V
- TPD32-500/520-...-4B** Four quadrant converter for AC input voltage up to 500 V
- TPD32-500/600-...-2B** Two quadrant converter for AC input voltage up to 500 V
- TPD32-690/720-...-4B** Four quadrant converter for AC input voltage up to 690 V
- TPD32-690/890-...-2B** Two quadrant converter for AC input voltage up to 690 V

The available size are listed in the following table:

*Table 2.1.1: Converter size*

| American             | Rated DC Current [A] |     | European              | Rated DC Current [A] |      |
|----------------------|----------------------|-----|-----------------------|----------------------|------|
|                      | 4B                   | 2B  |                       | 4B                   | 2B   |
| TPD32-.../...-17-..  | 17                   | 17  | TPD32-.../...-20-..   | 20                   | 20   |
| TPD32-.../...-35-..  | 35                   | 35  | TPD32-.../...-40-..   | 40                   | 40   |
| TPD32-.../...-56-..  | 56                   | 56  | TPD32-.../...-70-..   | 70                   | 70   |
| TPD32-.../...-88-..  | 88                   | 88  | TPD32-.../...-110-..  | 110                  | 110  |
| TPD32-.../...-112-.. | 112                  | 112 | TPD32-.../...-140-..  | 140                  | 140  |
| TPD32-.../...-148-.. | 148                  | 148 | TPD32-.../...-185-..  | 185                  | 185  |
| TPD32-.../...-224-.. | 224                  | 224 | TPD32-.../...-280-..  | 280                  | 280  |
| TPD32-.../...-280-.. | 280                  | 280 | TPD32-.../...-350-..  | 350                  | 350  |
| TPD32-.../...-336-.. | 336                  | 336 | TPD32-.../...-420-..  | 420                  | 420  |
| TPD32-.../...-400-.. | 400                  | 400 | TPD32-.../...-500-..  | 500                  | 500  |
| TPD32-.../...-450-.. | 450                  | 450 | TPD32-.../...-650-..  | 650                  | 650  |
| TPD32-.../...-560-.. | 560                  | 560 | TPD32-.../...-770-..  | 770                  | 770  |
| TPD32-.../...-800-.. |                      | 800 | TPD32-.../...-1000-.. |                      | 1000 |
| TPD32-.../...-850-.. | 850                  |     | TPD32-.../...-1050-.. | 1050                 |      |

**Note!**

The converter sizes up to 1000A “B / 1050A 4B are made by compact execution. The drive of higher sizes and with a main power supply at 690V are made by a regulation section and an external bridge. The technical data of those versions are indicated on “Addendum TPD32 External Bridge” manual.

The converter choice is made on the basis of the motor rated current and of the available AC input voltage. The output rated current must be higher or equal to the one required by the used motor.

## **Functions and features (Overview)**

The devices of the TPD32 series are developed as converters with excellent regulation features and a wide function range.

Integrated field converter.

- Galvanic separation and high impedance between the power and the regulation section.
- Galvanic separation between the regulation section and the digital I/O terminals.
- Differential analog inputs.
- Diagnostic LED module (KC) supplied as a standard and mounted on the drive front cover
- Removable optional Keypad (KB)

START UP menu which makes set-up easier.

Simple operation of the device

- via terminal strip
- via keypad with a back-lit keypad
- via a default set PC program and RS485 serial interface
- via a connection with a Field Bus (option), INTERBUS S with a DRIVECOM profile, PROFIBUS DP and GENIUS.

Stored messages concerning the last 10 faults and indication of the operation time.

Separate configuration of the drive behaviour for each message in an alarm situation.

Automatic change into an armature feedback because of the interruption of the speed feedback signal (only in constant torque mode).

Overload control

Three freely configurable analog inputs on the standard device.

Widening of digital inputs and of digital, analog outputs via a option card.

Reference assignation and display of the feedback values as a percentage or in a dimension which can be defined by the user.

Possibility of a speed and torque regulation

Adaptive of the speed regulator

Current predictive regulator with an automatic adaptation.

Motor potentiometer function (increase / decrease speed command).

Jog function.

8 internal speed references.

5 internal linear or S-shaped ramps.

Internal signal conditioning (gains, min/max limits, offset...).

Function widening available for specific applications (option).



## **2.2 UPON DELIVERY INSPECTION PROCEDURES**

### **Storage, Transport**

A high degree of care is taken in packing the converters of the TPD32 series and preparing them for delivery. They should only be transported with suitable transport equipment (see weight data). Observe the instructions printed on the packaging. This also applies when the device is unpacked up to when it is installed in the control cabinet.

On delivery check the following:

- the packaging for any external damage
- whether the delivery note matches your order.

Open the packaging with suitable tools. Check whether

- any parts were damaged during transport
- the device type corresponds to your order

In the event of any damage or of an incomplete or incorrect delivery please notify the sales offices responsible immediately.

The devices should only be stored in dry rooms within the temperature ranges specified.

**Note!** A certain degree of moisture condensation is permissible if this arises from changes in temperature (see section 3.1, “Permissible Ambient Conditions”) This does not, however, apply when the devices are in operation. Ensure always that there is no moisture condensation in devices that are connected to the power supply!

### **2.2.1 Device setting**

The converters of the TPD32 series can operate connected to an AC input three-phase voltage from 230V to 690V. Inside this voltage range the device setting is carried out on the basis of the motor rated current. Therefore the converter rated current must be higher or the same as the motor rated one.

If an overload is necessary, the setting is carried out according to the example mentioned in section 6.14.6, “Overload control”, so that the overcurrent must not be supplied in a continuative way from the type of the chosen converter.

**Note!** A reduction factor should be considered if the converter is installed at altitudes of over 3,300 feet (1000 m) above sea level and at higher temperatures (see section 3.1, “Permissible ambient conditions”).



## Example for a 15kW motor

AC input voltage: 400 V, 3Ph

### 1. Two quadrant functioning

|                 |                  |                     |
|-----------------|------------------|---------------------|
| Nameplate data: | Power            | 15 kW               |
|                 | Armature Voltage | 470 V <sub>DC</sub> |
|                 | Armature Current | 37,6 Amps           |
|                 | Field Voltage    | 310 V <sub>DC</sub> |
|                 | Field Current    | 0.8 Amps            |

|                  |              |                        |
|------------------|--------------|------------------------|
| Choice criteria: | 400 V, 3Ph   | see section "AC Input" |
|                  | 37.6A < 40 A | see section "AC Ouput" |
|                  | 0.8 A < 10 A | see section "AC Ouput" |

Chosen converter: TPD32-400/470-40-2B

The converter can supply 1,06 of motor rated current continuously. If higher overload values are required, see section 6.14.6, "Overload control".

### 2. Four quadrant functioning

|                 |                  |                     |
|-----------------|------------------|---------------------|
| Nameplate data: | Power            | 15 kW               |
|                 | Armature Voltage | 420 V <sub>DC</sub> |
|                 | Armature Current | 42 Amps             |
|                 | Field Voltage    | 310 V <sub>DC</sub> |
|                 | Field Current    | 0,8 Amps            |

|                  |              |                         |
|------------------|--------------|-------------------------|
| Choice criteria: | 400 V, 3Ph   | see section "AC Input"  |
|                  | 42 A < 70 A  | see section "AC Output" |
|                  | 0,8 A < 10 A | see section "AC Output" |

Chosen converter: TPD32-400/470-70-4B

The converter can supply 1,66 of motor rated current continuously. If higher overload values are required, see section 6.14.6, "Overload control".

## 2.3 DRIVE KEYPAD DESCRIPTION

### Keypad

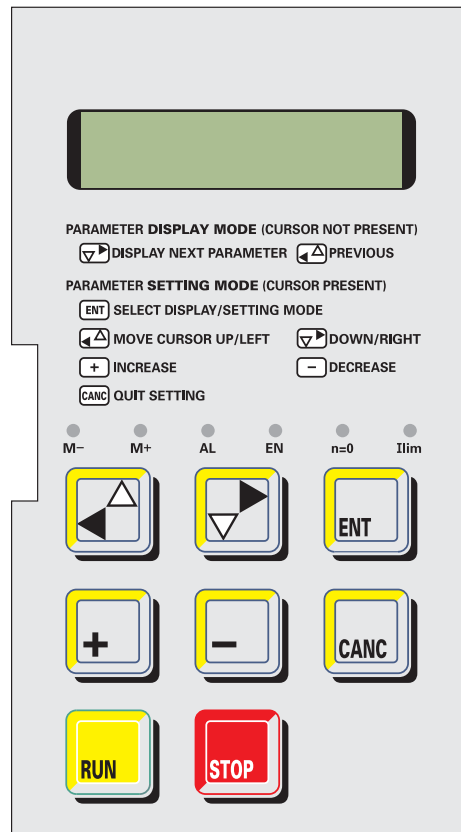

The keypad is made of a LCD display with two 16- digit lines and of 8 function buttons.

It is used:

- to command the drive when this system has been selected
- to display the speed, the voltage ..... during the operating time
- to set parameters

#### LED module KC

In the standard delivery the convert is supplied with the led module mounted on the front cover.

It contains six leds for an easy monitoring of the converter status.

The KC module can be manually removed and replaced with the Keypad , which is connected to the regulation board through the dedicated connector.

On the Keypad, which is supplied as optional, the same leds at the KC module are mounted.

## LEDs

Table 2.3.1: Keypad LEDs

| Designation | Color  | Function  |
|-------------|--------|---|
| - Torque    | yellow | the LED is lit, when the drive operates with a negative torque (anti-clockwise rotation or clockwise braking). Only for TPD32-...-4B.         |
| + Torque    | yellow | the LED is lit, when the drive operates with a positive torque (clockwise rotation or anti-clockwise braking). Braking only for TPD32-...-4B. |
| Alarm       | red    | the LED is lit, it signals the intervention and the alarm condition   |
| Enable      | green  | the LED is lit, when the converter is enabled   |
| Zero Speed  | yellow | the LED is lit, when the motor speed is lower than the threshold set by Speed zero level  |
| I Limit     | yellow | the LED is lit, when the converter operates at a current limit  |

## 2.4 SPECIFICATIONS

### 2.4.1 Standards

|                        |   |
|------------------------|---|
| General:               | EN 61800-1, EN 50178.   |
| Climatic conditions:   | IEC 68-2 part 2 and 3 (EN 60068-2-2, test Bd).  |
| Isolations distances:  | IEC 664, IEC 664 A; Environment pollution degree 2.   |
| Interference immunity: | EN 61000-4-4, Interference immunity level 4<br>EN 61000-4-2, Interference immunity level 6 kV CD / 8 kV AD. |
| Oscillation test:      | EN 60068-2-6, test Fc.  |
| EMC compatibility:     | EN 68100-3, see information in “Guide to the electromagnetic compatibility”.                                |
| Safety:                | EN 50178.   |
| Protection degree:     | EN 60529.   |
| UL approval:           | According to file No. E183859 for approved drives series.   |

## 2.4.2 AC Input

Table 2.4.2.1: AC input voltages

| DC Drive series | Power section<br>(U/V/W terminals)   | Field circuit<br>(U1/V1 terminals)                         | Power supply regulation section<br>(U2/V2 terminals) |
|-----------------|--|--|--|
| TPD32-400/...   | 230 V ±10 %*, 3Ph<br>400 V ±10 %*, 3Ph   | 230 V ±10 %*, 1Ph<br>400 V ±10 %*, 1Ph<br>460 V ±10 %, 1Ph | 115 V ±15 % **, 1Ph<br>or<br>230 V ±15 % **, 1Ph     |
|                 | 50/60 Hz ±5 %  |  |  |
| TPD32-500/...   | 230 V ±10 %*, 3Ph<br>400 V ±10 %*, 3Ph<br>440 V ±10 %, 3Ph<br>460 V ±10 %, 3Ph<br>480 V ±10 %, 3Ph<br>500 V ±10 %, 3Ph | 50/60 Hz ±5 %  | 50 / 60 Hz ±5 %                                      |
|                 | 50/60 Hz ±5 %  |  |  |

\* With the indicated tolerance values the output voltage complies the DIN 40030 standard.  
With wider tolerances the max output voltage changes accordingly.

\*\* **To work at 115 V with drives from 280 Amps and above a jumper between terminals SA - SB S(placed on the rear side of the drive) must be inserted.**

During start-up the threshold for the undervoltage message has to be set via the **Undervolt thr** parameter (standard: 230 V).

**Note!** According the input voltage the switch S15.7/8 on the regulation board must be set as follows:

|               |             |             |
|---------------|-------------|-------------|
| TPD32-400/... | S15.7 = OFF | S15.8 = OFF |
| TPD32-500/... | S15.7 = ON  | S15.8 = OFF |
| TPD32-690/... | S15.7 = OFF | S15.8 = ON  |

**Note!** As for the operation of the TPD32 converters AC input reactors and interference suppression filters are required. See section 4.10, “Reactors/Filters”.

The converters above 770 A and the AC input reactors have a discharge currents to ground higher than 3.5 mA. EN 50178 states that beside the ground conductor another ground connection should be laid.

**Caution!** Due to the increased discharge current involved, a fixed ground connection (without connectors) for the filters of the TPD32 converter is required.

## Current /Power on AC input

**Note!** The values showed on table below are referred to a converter functioning at nominal current  $I_{dN}$  (armature) and  $I_{pN}$  (field).

Table 2.4.2.2: AC input currents

| American             | Current on the AC Input | European              | Current on the AC Input | Current on the field AC Input | Power Supply Regulation |        |
|----------------------|-------------------------|-----------------------|-------------------------|-------------------------------|-------------------------|--------|
|                      |                         |                       |                         |                               | Power                   | Card   |
| TPD32-.../...-17-..  | 14.6 A                  | TPD32-.../...-20-..   | 17.2 A                  | 10 A                          | 70W                     | SW1-31 |
| TPD32-.../...-35-..  | 30.1 A                  | TPD32-.../...-40-..   | 34.4 A                  | 10 A                          |                         |        |
| TPD32-.../...-56-..  | 48.1 A                  | TPD32-.../...-70-..   | 60.2 A                  | 10 A                          |                         |        |
| TPD32-.../...-88-..  | 75.6 A                  | TPD32-.../...-110-..  | 94.6 A                  | 14 A                          |                         |        |
| TPD32-.../...-112-.. | 96.2 A                  | TPD32-.../...-140-..  | 120.4 A                 | 14 A                          |                         |        |
| TPD32-.../...-148-.. | 127.2 A                 | TPD32-.../...-185-..  | 159.1 A                 | 20 A                          | 110W                    | SW2-32 |
| TPD32-.../...-224-.. | 192.5 A                 | TPD32-.../...-280-..  | 240.8 A                 | 20 A                          |                         |        |
| TPD32-.../...-280-.. | 240.6 A                 | TPD32-.../...-350-..  | 301 A                   | 20 A                          |                         |        |
| TPD32-.../...-336-.. | 288.7 A                 | TPD32-.../...-420-..  | 361.2 A                 | 20 A                          |                         |        |
| TPD32-.../...-400-.. | 343.7 A                 | TPD32-.../...-500-..  | 430 A                   | 20 A                          |                         |        |
| TPD32-.../...-450-.. | 386.7 A                 | TPD32-.../...-650-..  | 559 A                   | 20 A                          | 110W                    | SW3-32 |
| TPD32-.../...-560-.. | 481.2 A                 | TPD32-.../...-770-..  | 662.2 A                 | 25 A                          |                         |        |
| TPD32-.../...-800-.. | 687.4 A                 | TPD32-.../...-1000-.. | 860 A                   | 25 A                          |                         |        |
| TPD32-.../...-850-.. | 730.4 A                 | TPD32-.../...-1050-.. | 903 A                   | 25 A                          |                         |        |

## 2.4.3 Output

**Note!** It is not possible to connect an external voltage to the converter output terminals! It is not even possible to disconnect the motor from the device output while the drive is active.

In normal cases no leveling choke is necessary. It must be taken into account, anyway, that some motor producers prescribe such a choke according to the type of the motor used. In this case it must be inserted on the motor cable.

The stated currents refer to the continuous operation with an ambient temperature of 104°F (40° C).

## Output current

### Armature circuit

Table 2.4.3.1: Output currents

| American             |  |  | European              |  |  | Field converter                                  |
|----------------------|--|--|-----------------------|--|--|--|
| Type                 | Armature current<br>(Terminals C / D)            |  | Type                  | Armature current<br>(Terminals C / D)            |  | (Term. C1 / D1)                                  |
|                      | Continuous curr.<br>with Ambient<br>temp @ 104°F | *Max. current<br>(with overload)<br>** |                       | Continuous curr.<br>with Ambient<br>temp @ 104°F | *Max. current<br>(with overload)<br>** | Continuous curr.<br>with Ambient<br>temp @ 104°F |
| TPD32-.../...-17-..  | 17 A   | 34 A                                   | TPD32-.../...-20-..   | 20 A   | 40 A                                   | 10 A   |
| TPD32-.../...-35-..  | 35 A   | 70 A                                   | TPD32-.../...-40-..   | 40 A   | 80 A                                   | 10 A   |
| TPD32-.../...-56-..  | 56 A   | 112 A                                  | TPD32-.../...-70-..   | 70 A   | 140 A                                  | 10 A   |
| TPD32-.../...-88-..  | 88 A   | 172 A                                  | TPD32-.../...-110-..  | 110 A  | 220 A                                  | 14 A   |
| TPD32-.../...-112-.. | 112 A  | 224 A                                  | TPD32-.../...-140-..  | 140 A  | 280 A                                  | 14 A   |
| TPD32-.../...-148-.. | 148 A  | 296 A                                  | TPD32-.../...-185-..  | 185 A  | 370 A                                  | 14 A   |
| TPD32-.../...-224-.. | 224 A  | 448 A                                  | TPD32-.../...-280-..  | 280 A  | 560 A                                  | 20 A   |
| TPD32-.../...-280-.. | 280 A  | 560 A                                  | TPD32-.../...-350-..  | 350 A  | 700 A                                  | 20 A   |
| TPD32-.../...-336-.. | 336 A  | 672 A                                  | TPD32-.../...-420-..  | 420 A  | 840 A                                  | 20 A   |
| TPD32-.../...-400-.. | 400 A  | 800 A                                  | TPD32-.../...-500-..  | 500 A  | 1000 A                                 | 20 A   |
| TPD32-.../...-450-.. | 450 A  | 900 A                                  | TPD32-.../...-650-..  | 650 A  | 1300 A                                 | 20 A   |
| TPD32-.../...-560-.. | 560 A  | 1120 A                                 | TPD32-.../...-770-..  | 770 A  | 1540 A                                 | 25 A   |
| TPD32-.../...-800-.. | 800 A  | 1600 A                                 | TPD32-.../...-1000-.. | 1000 A   | 2000 A                                 | 25 A   |
| TPD32-.../...-850-.. | 850 A  | 1700A                                  | TPD32-.../...-1050-.. | 1050 A   | 2100 A                                 | 25 A   |

\* Current reduction for higher temperatures, see section 3.1, “Permissible ambient conditions”.

\*\* The overload size and duration depend on the overload cycle, see section 6.14.6, “Overload control”

As for sizes above 850 / 1050 A (American / European) see “DC Drives with external bridge” Addendum.

#### Note!

The field motor current can sometimes be very small compared with rated field current of the converter. In order to provide regulation during Voltage control of the motor, follow the described instructions to change the Flux current max of the converter. In this case the **Nom field scale** parameter must be set with the new rated field current value.

### Field circuit

The TPD32 regulation card is shipped with the field current feedback resistor dipo switches S14 calibrated for the maximum rating of the field package capacity for each size TPD32 .

Compare the actual motor field data to the maximum rating of the field package of the TPD32 model supplied (see table 2.4.3.1), and to the field calibration dipswitch S14, as noted below.

- For fixed field current operation, if the actual motor (base) field current  $\leq 10\%$  of the maximum rating of the field package it is required to calibrate the field current feedback scaling using dipswitch S14.
- For weak field operation, also referred as “CEMF field control” or “crossover field control”, if the top base speed Motor nom flux  $\leq 10\%$  of the maximum rating of the field package it is required to calibrate the field current feedback scaling using dipswitch S14.

Calibration to the exact field current setting is not required, as long as the above conditions are met.

Calibration is not required if the field control is provided by a separate field converter.

In order to obtain a current setting value different from those stated in the table, use the following formula to

calculate the resistance to be used between the terminals LA and LB on the regulation card. In this case all the switches have to be set to zero (OFF).

**TPD32 Rev. 7.1 and higher;** resistance for the field current calibration.

**For sizes TPD32-.../...-20... up to TPD32-.../...-1050... :** Resistance = 1667 / field current (A).

**For model numbers TPD32-...-1010-... to TPD32-...-3300-... the formula is in “DC Drives with external bridge” Addendum.**

Table 2.4.3.2: Field current resistors

| Switch ohms   | 168.5 Ohm | 333 Ohm | 182 Ohm | 36.4 Ohm | 845 Ohm | 1668 Ohm |          |       | Equivalent resistance |
|---------------|-----------|---------|---------|----------|---------|----------|----------|-------|-----------------------|
| Nom flux curr | S14-1     | S14-2   | S14-3   | S14-4    | S14-5   | S14-6    | S14-7    | S14-8 |                       |
| 1.0 A         | OFF       | OFF     | OFF     | OFF      | OFF     | ON       | Not used |       | 1668 Ohm              |
| 2.0 A         | OFF       | OFF     | OFF     | OFF      | ON      | OFF      |          |       | 845 Ohm               |
| 3.0 A         | OFF       | OFF     | OFF     | OFF      | ON      | ON       |          |       | 560.9 Ohm             |
| 5.0 A         | OFF       | ON      | OFF     | OFF      | OFF     | OFF      |          |       | 333.3 Ohm             |
| 9.9 A         | ON        | OFF     | OFF     | OFF      | OFF     | OFF      |          |       | 168.5 Ohm             |
| 12.9 A        | ON        | OFF     | OFF     | OFF      | ON      | ON       |          |       | 129.6 Ohm             |
| 14.2 A        | OFF       | ON      | ON      | OFF      | OFF     | OFF      |          |       | 117.7 Ohm             |
| 17.1 A        | OFF       | ON      | ON      | OFF      | ON      | ON       |          |       | 97.3 Ohm              |
| 20.0 A        | ON        | OFF     | ON      | OFF      | OFF     | ON       |          |       | 83.1 Ohm              |
| 24.1 A        | ON        | ON      | ON      | OFF      | OFF     | OFF      |          |       | 69.3 Ohm              |
| 25.1 A        | ON        | ON      | ON      | OFF      | OFF     | ON       |          |       | 66.5 Ohm              |

## Output voltage

The below mentioned output voltages take into account an AC input undervoltage within the stated tolerance limits and a voltage drop of 4% due to the inserted AC input reactors. It is the same as the rated armature voltage suggested for the connected motor.

## Armature circuit

Table 2.4.3.3: Armature circuit output voltages

| AC input voltage<br>(Terminals U / V / W) | Output Armature voltage (Terminals C / D) |                         |
|---|---|-------------------------|
|   | Two quadrant converter                    | Four quadrant converter |
| 230 V ±10 %, 3Ph                          | 260 V                                     | 240 V                   |
| 400 V ±10 %, 3Ph                          | 470 V *                                   | 420 V *                 |
| 440 V ±10%, 3Ph                           | 530 V                                     | 460 V                   |
| 460 V ±10%, 3Ph                           | 560 V                                     | 480 V                   |
| 480 V ±10%, 3Ph                           | 580 V                                     | 500 V                   |
| 500 V ±10%, 3Ph                           | 600 V                                     | 520 V *                 |

\* Voltage measured as per DIN 40 030 (09/93)

## Field circuit

Table 2.4.3.4: Field circuit output voltages

| AC input voltage<br>(Terminals U1 / V1) | Output field voltage** (Terminals C1/D1) |                  |
|---|--|------------------|
|   | Fixed field                              | Adjustable field |
| 230 V ±15 %, 1Ph                        | 200 V *                                  | 200 V *          |
| 400 V ±15 %, 1Ph                        | 310 V *                                  | 310 V *          |
| 460 V ±10%, 1Ph                         | 360 V                                    | 360 V            |

\* Voltage measured as per DIN 40 030 (09/93)

\*\* The max field voltage is equal to 0.85 x AC input line voltage

## 2.4.4 Control section

|                                    |            |                  |  |
|------------------------------------|------------|------------------|--|
| <b>Enables</b>                     |            | 0 / 15...30 V    | 3.2...6.4 mA (approx. 5 mA at 24 V)  |
| <b>Analog inputs</b>               | option     | 0... ± 10 V      | 0.25mAmax  |
|                                    |            | 0...20 mA        | 10 V max   |
|                                    |            | 4...20 mA        | 10 V max   |
| <b>Analog outputs</b>              |            | 0...± 10 V       | 5 mA max each output   |
| <b>Digital inputs</b>              |            | 0 / 15...30 V    | 3.2...6.4 mA (approx. 5 mA at 24 V)  |
| <b>Digital outputs</b>             | supply     | + 15...35 V      |  |
|                                    | signal     | + 15...35 V      | 20 mA max each output  |
| <b>Encoder inputs</b>              |            |                  |  |
|                                    | Sinusoidal | voltage          | 1 V pp   |
|                                    |            | current          | 8.3 mA pp each channel (input resistance = 124 ohm)  |
|                                    |            | pulses per rev   | min 600            max 9999  |
|                                    |            | max frequency    | 150 kHz  |
|                                    |            | max cable length | screened, 150m (0.75 mm <sup>2</sup> ) / 125m (0.5 mm <sup>2</sup> ) / 55m (0.22 mm <sup>2</sup> ) |
|                                    | Digital    | voltage          | 5V TTL / 15...24V HTL (H logic)  |
|                                    |            | current          | 4.5 mA / 6.8 ... 10.9 mA each channel with H logic   |
|                                    |            | pulses per rev   | min 600            max 9999  |
|                                    |            | max frequency    | 150 kHz  |
|                                    |            | max cable length | screened, 150m (0.75 mm <sup>2</sup> ) / 125m (0.5 mm <sup>2</sup> ) / 55m (0.22 mm <sup>2</sup> ) |
| <b>Analog tachogenerator input</b> |            |                  |  |
|                                    |            | voltage          | 22.7 / 45.4 / 90.7 / 181.6 / 302.9 V max,<br>depending on the switch S4 setting                    |
|                                    |            | current          | 8 mA full scale  |
|                                    |            | max cable length | screened, the max length depends on the installation, typical 150m                                 |
| <b>Internal supply voltage</b>     |            |                  |  |
|                                    | max load   | + 5 V            | 160 mA            encoder connector, PIN 7/9<br>(only for sinusoidal encoder)                      |
|                                    |            | + 10 V           | 10 mA            terminal 7  |
|                                    |            | - 10 V           | 10 mA            terminal 8  |
|                                    |            | + 24 V           | 200 mA           terminal 19   |
|                                    |            |                  | encoder connector, PIN 2/9<br>(only for digital encoder)   |
|                                    | tolerance  | + 10 V           | ± 3 % <sup>1)</sup>  |
|                                    |            | - 10 V           | ± 3 % <sup>1)</sup>  |
|                                    |            | + 24 V           | + 20 ... 30 V, not stabilized  |

<sup>1)</sup> The values of the voltages + 10V and -10V are the same. The stated tolerance refers to the voltage width.



## 2.4.5 Accuracy

### Internal reference voltage ( $\pm 10V$ , terminals 7 or 8):

temperature dependent stability error 100 ppm/ $^{\circ}C$

### References

via keypad/serial line/Bus

resolution: 16 Bit or 15 Bit + sign

via terminals (1/2, 3/4, 5/6)

resolution: 11 Bit + sign

linearity  $\pm 0.1\%$  of the full range value

### Analog outputs (TBO only)

resolution: 11 Bit + sign

linearity:  $\pm 0.5\%$  of the full range value

### Speed regulation

for all the operation mode

max speed 8000 rpm

digital reference resolution: 0.25 rpm

analog reference resolution:  $\geq 0.25$  rpm

with sinusoidal encoder

speed feedback resolution: 0.25 rpm

accuracy typical 0.01%

control range better than 1:10000

with digital encoder

speed feedback resolution 0.5 rpm

accuracy typical 0.02%

control range better than 1:1000

with tachogenerator

speed feedback resolution better than 1:2000

accuracy typical 0.1%

control range better than 1:1000

### Torque regulation

resolution better than 1:2000

accuracy typical 0.2%

control range better than 1:500

## 2.5 DIMENSION AND WEIGHTS

Fig. 2.5.1: Drive dimensions for 20 A ... 70 A sizes (form 1)

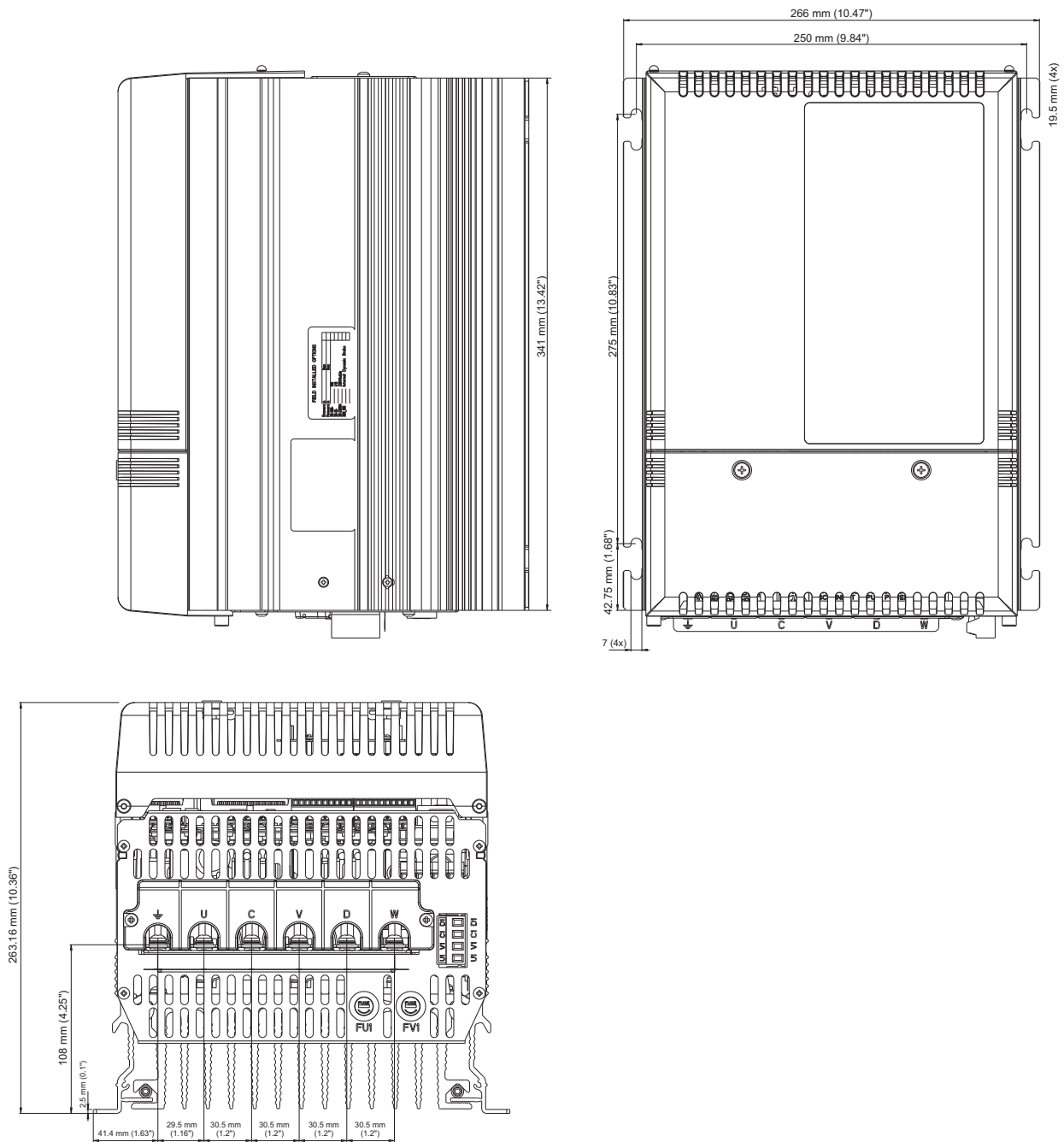

| American         | European         | Form | Weight<br>Pounds / Kg |
|------------------|------------------|------|-----------------------|
| TPD32-.../-17-.. | TPD32-.../-20-.. | 1    | 18.5 / 8.4            |
| TPD32-.../-35-.. | TPD32-.../-40-.. |      | 18.5 / 8.4            |
| TPD32-.../-56-.. | TPD32-.../-70-.. |      | 19.4 / 8.8            |

Fig. 2.5.2: Drive dimensions for 110 A ... 185 A sizes (form 1)

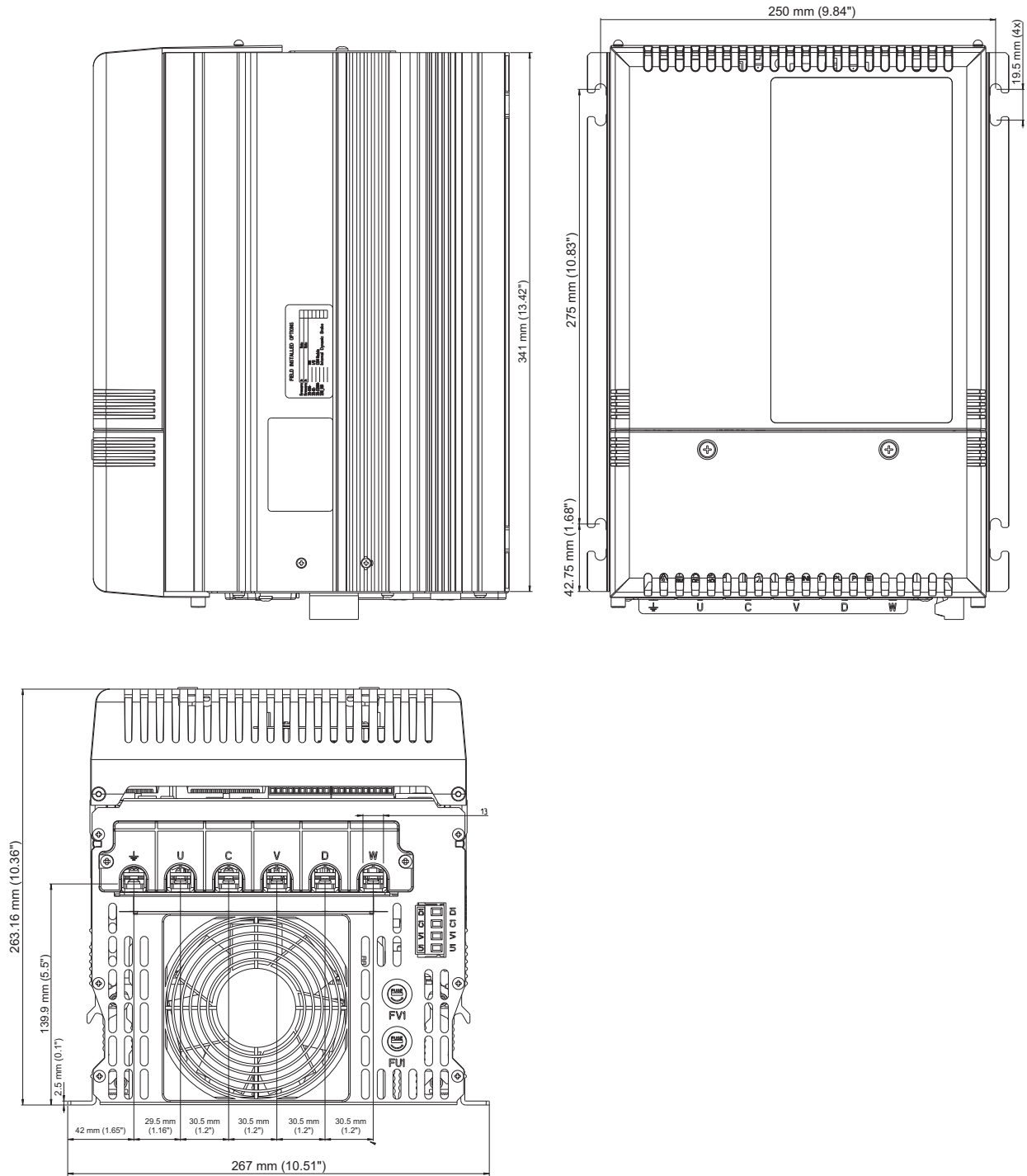

| American             | European             | Form | Weight<br>Pounds / Kg |
|----------------------|----------------------|------|-----------------------|
| TPD32-.../...-88-..  | TPD32-.../...-110-.. | 1    | 23,8 / 10,8           |
| TPD32-.../...-112-.. | TPD32-.../...-140-.. |      | 23,8 / 10,8           |
| TPD32-.../...-148-.. | TPD32-.../...-185-.. |      | 23,8 / 10,8           |

Fig. 2.5.3: Drive dimensions for 280 A ... 420 A sizes (form 2)

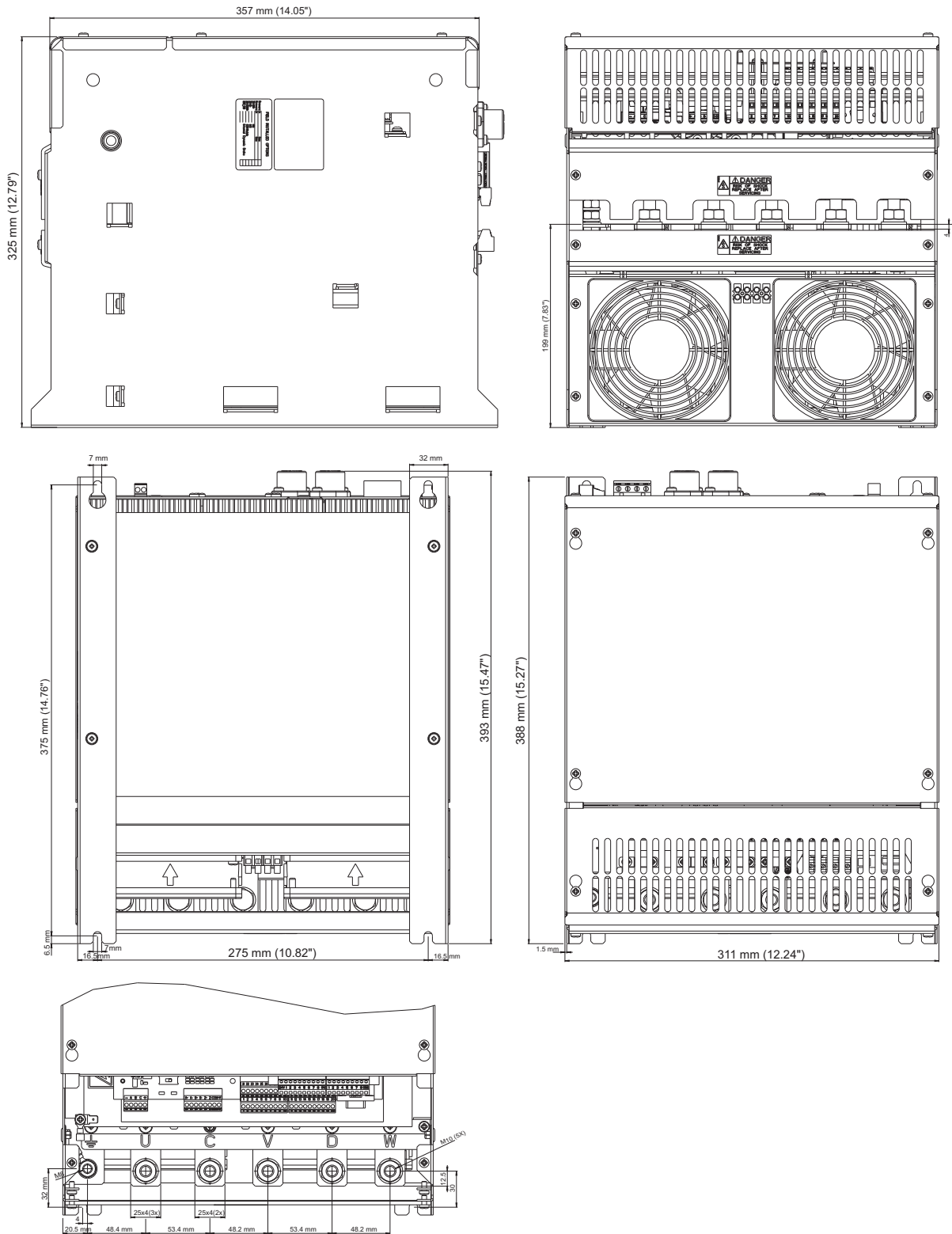

| American         | European         | Form | Weight<br>Pounds / Kg |
|------------------|------------------|------|-----------------------|
| TPD32-...-224-.. | TPD32-...-280-.. | 2    | 54,0 / 24,5           |
| TPD32-...-280-.. | TPD32-...-350-.. |      | 54,0 / 24,5           |
| TPD32-...-336-.. | TPD32-...-420-.. |      | 65,0 / 29,5           |

Fig. 2.5.4: Drive dimensions for 500 A ... 650 A sizes (form 2)

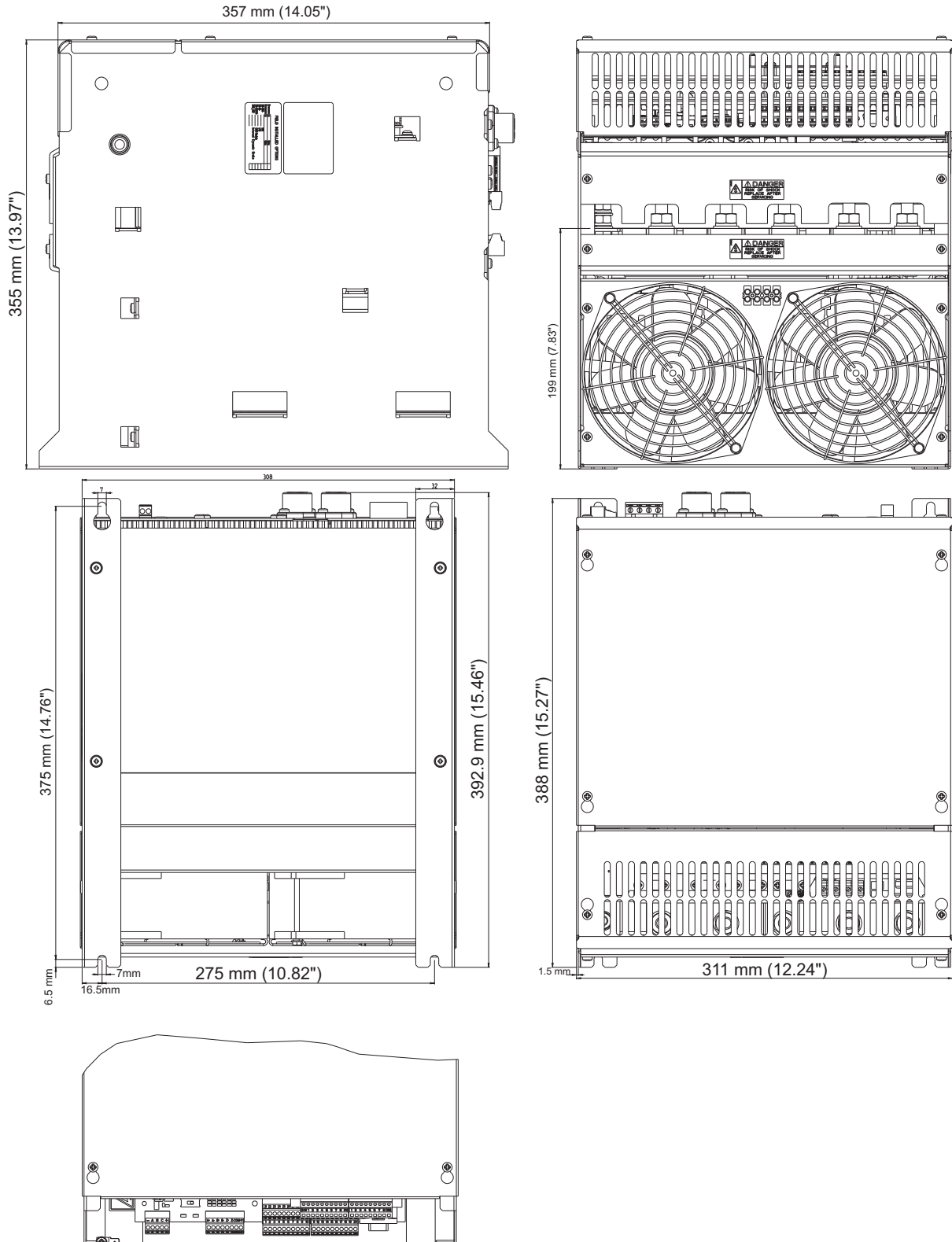

| American             | European             | Form | Weight<br>Pounds / Kg |
|----------------------|----------------------|------|-----------------------|
| TPD32-.../...-400-.. | TPD32-.../...-500-.. | 2    | 65,0 / 29,5           |
| TPD32-.../...-450-.. | TPD32-.../...-650-.. |      | 70,6 / 32             |

Fig. 2.5.5: Drive dimensions for 770 A ... 1050 A sizes (form 3)

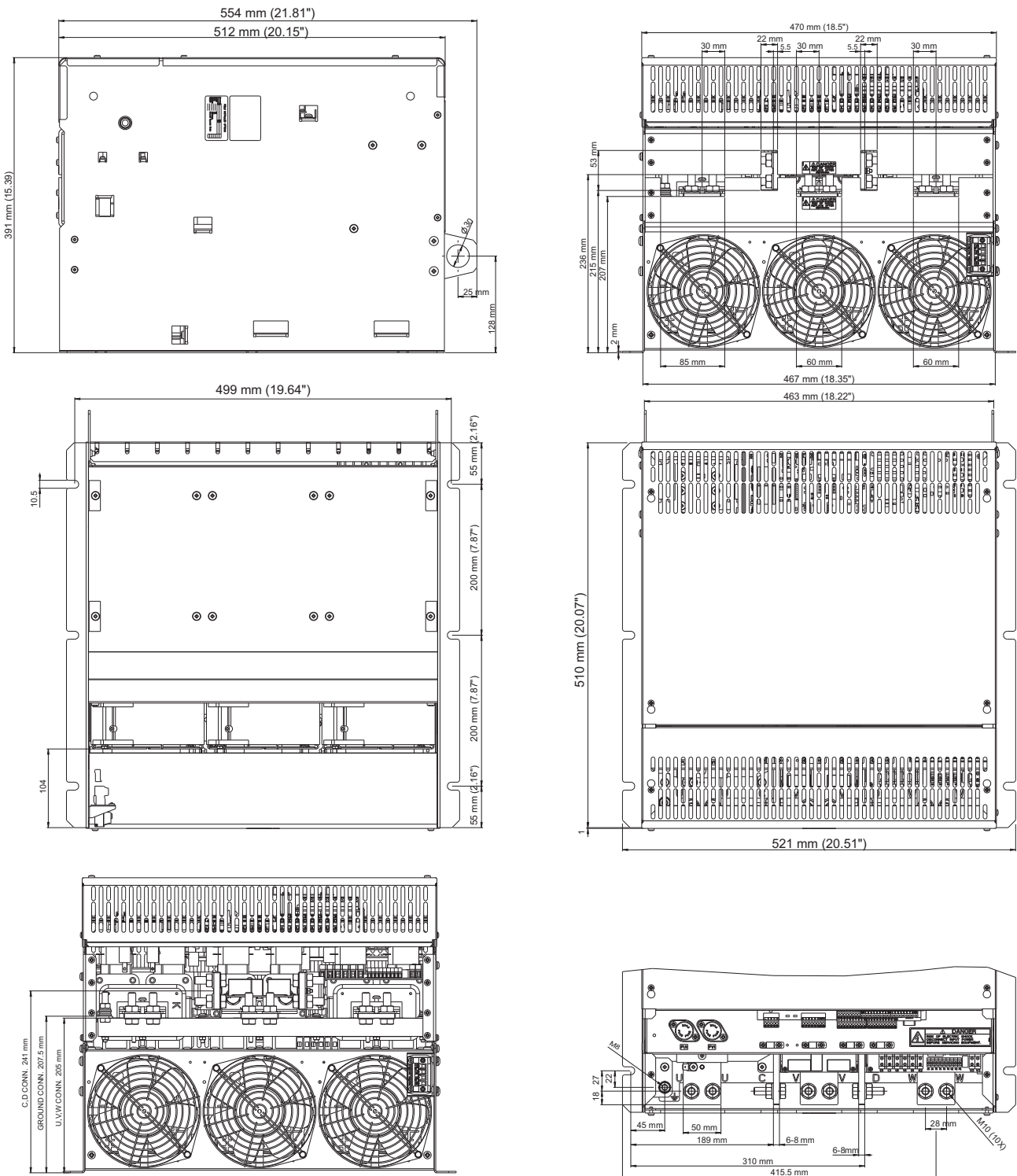

| American             | European              | Form | Weight<br>Pounds / Kg |
|----------------------|-----------------------|------|-----------------------|
| TPD32-.../...-560-.. | TPD32-.../...-770-..  | 3    | 134,5 / 61            |
| TPD32-.../...-800-.. | TPD32-.../...-1000-.. |      | 143,3 / 65            |
| TPD32-.../...-850-.. | TPD32-.../...-1050-.. |      | 143,3 / 65            |

## 2.6 WATT LOSS

The power dissipation on the converter side depends on the AC input voltage. The values of the dissipated powers stated in the following table refer to the functioning with rated current.

**Note!** The mounting should take into consideration a free space above and below the device of at least 6 inches (150 mm). (Air circulation).

Starting from the type 770 A, the fans must be supplied from the outside with a single-phase voltage of 230V 50/60 Hz (terminals U3 & V3).

| American             | European              | Power loss<br>$P_v$ [W] | Fans                  |                         |  | Enclosure                              |                     |
|----------------------|-----------------------|-------------------------|-----------------------|-------------------------|--|--|---------------------|
|                      |                       |                         | Voltage<br>[V]        | Rated<br>current<br>[A] | Air<br>capacity<br>[m <sup>3</sup> /h] | ventilation area<br>[mm <sup>2</sup> ] | [in. <sup>2</sup> ] |
| TPD32-.../...-17-..  | TPD32-.../...-20-..   | 131                     | -                     | -                       | -                                      | 2 x 5100                               | 2 x 7.91            |
| TPD32-.../...-35-..  | TPD32-.../...-40-..   | 186                     | -                     | -                       | -                                      | 2 x 5100                               | 2 x 7.91            |
| TPD32-.../...-56-..  | TPD32-.../...-70-..   | 254                     | Internal power supply | -                       | 80                                     | 2 x 5100                               | 2 x 7.91            |
| TPD32-.../...-88-..  | TPD32-.../...-110-..  | 408                     |                       |                         | 160                                    | 2 x 11300                              | 2 x 17.53           |
| TPD32-.../...-112-.. | TPD32-.../...-140-..  | 476                     |                       |                         | 160                                    | 2 x 11300                              | 2 x 17.53           |
| TPD32-.../...-148-.. | TPD32-.../...-185-..  | 553                     |                       |                         | 160                                    | 2 x 11300                              | 2 x 17.53           |
| TPD32-.../...-224-.. | TPD32-.../...-280-..  | 781                     |                       |                         | 320                                    | 2 x 22600                              | 2 x 35.06           |
| TPD32-.../...-280-.. | TPD32-.../...-350-..  | 939                     |                       |                         | 320                                    | 2 x 22600                              | 2 x 35.06           |
| TPD32-.../...-336-.. | TPD32-.../...-420-..  | 1038                    |                       |                         | 320                                    | 2 x 22600                              | 2 x 35.06           |
| TPD32-.../...-400-.. | TPD32-.../...-500-..  | 1248                    |                       |                         | 320                                    | 2 x 22600                              | 2 x 35.06           |
| TPD32-.../...-450-.. | TPD32-.../...-650-..  | 1693                    |                       |                         | 680                                    | 2 x 35400                              | 2 x 54.91           |
| TPD32-.../...-560-.. | TPD32-.../...-770-..  | 2143                    |                       |                         | 230                                    | 0.75                                   | 1050                |
| TPD32-.../...-800-.. | TPD32-.../...-1000-.. | 2590                    | 230                   | 0.75                    | 1050                                   | 2 x 53100                              | 2 x 82.37           |
| TPD32-.../...-850-.. | TPD32-.../...-1050-.. | 2590                    | 230                   | 0.75                    | 1050                                   | 2 x 53100                              | 2 x 82.37           |

Table 2.6.1: Power Dissipation

\* When the Drive is mounted in a cabinet, door filters are required to meet pollution degree II ratings for UL.

## **2.7 MOTORS, ENCODER, TACHOMETER**

The converters of the TPD32 series are provided for the regulation of DC motors with an independent excitation. As for speed feedback there is the use of a sinusoidal incremental encoder, a digital encoder or an analog tachometer generator. In case of limited precision needs it is possible to use as feedback the armature voltage without defluxing.

### **2.7.1 Motors**

The electrical and mechanical data of the dc motors with an independent excitation refer to a particular functioning field. The following points have to be taken into consideration in order to operate these motors:

#### ***Motor data necessary to connect it to a converter***

The data on the motor nameplate:

- Armature rated voltage
- Armature rated current
- Field rated current
- Motor rated speed

#### ***Motor protection***

##### **Thermo relay of the motor**

- Placed above the converter: dimensioning  $I_{dN} \cdot 0.82 \cdot 1.05$
- The relay contact can stop the drive through a control circuit or it can signal to the converter as an external failure (terminal 15).

##### ***Note!***

Remember that with a thermo relay it is possible only to control the heating of the motor due to an overload, but not the one due to an insufficient ventilation. For this purpose some PTC thermistors or thermal switches should be inserted in the motor windings.

##### **Thermistors and thermal switches**

On terminals 78 and 79 it is possible to connect a thermistor or thermal switch in order to detect motor overheating. When no temperature sensors are present an external resistor ( $R = 1 \text{ kohm}$ ) has to be connected to these terminals. The connection of the sensor has to be done according the following instructions.

##### **Thermistors (PTC)**

PTC thermistors according to DIN 44081 or 44082 fitted in the motor can be connected directly to the converter via terminals 78 and 79. In this case the resistor (1 kohm) mounted between the terminals 78, 79 has to be removed.

##### **Thermal switches (klixons) in the motor windings**

Temperature-dependent contacts “klixon” type can disconnect the drive via the external control or can be reported as an external error on the converter (terminal 15). They can also be connected to the terminals 78 and 79 in order to have a specific error signal. In this case remove the 1 kohm resistor from these terminals and connect it in series to the wiring.



### **Limitation of the converter current**

The current limitation can protect the motor from unwanted overloads. To this purpose it is necessary to set the current limitation and the control function of the converter overload (overload function), so that the current remains within the values allowed for the motor.

**Note!** Remember that with a current limitation it is possible to control only the motor heating due to an overload, but not the one due to an insufficient ventilation. For this purpose some PTC thermistors or thermal switches should be inserted in the motor windings.

## 2.7.2 Encoder / Tachometer

The encoders and the tachometers give the speed feedback to the regulation. They have to be mounted on the motor shaft with joints without gaps. The best regulation results are possible by using incremental sinusoidal encoders; it is also possible to use digital incremental encoders or tachogenerators, see section, "Accuracy".

Features:

### Sinusoidal encoder

|                                 |                          |
|---------------------------------|--------------------------|
| max frequency                   | 150 kHz                  |
| number of pulses per revolution | min 600<br>max 9999      |
| channel                         | two-channel              |
| supply                          | + 5V (internal supply)   |
| load capacity                   | > 8.3 mA pp each channel |

### Digital encoder

|                                 |  |
|---------------------------------|--|
| max frequency                   | 150 kHz  |
| number of pulses per revolution | min 600<br>max 9999  |
| channels                        | two-channel, with complementary outputs                        |
| supply                          | + 5V / 15 ... 24V (external supply)<br>+ 24V (internal supply) |
| load capacity                   | > 4.5 mA / 6.8 ... 10.9 mA each channel                        |

### Analog tachometer

|                          |  |
|--------------------------|--|
| for TPD32-...-2B         | DC tacho (recommended), rectified AC tacho                                   |
| for TPD32-...-4B         | DC tacho only  |
| max voltage at max speed | 22.7 / 45.4 / 90.7 / 181.6 / 302.9 V, depending on the dip switch S4 setting |
| current                  | 8 mA, full scale   |

| Tacho voltage<br>input (V) | S4-1<br>S4-8 | S4-2<br>S4-7 | S4-3<br>S4-6 | S4-4<br>S4-5 |
|----------------------------|--------------|--------------|--------------|--------------|
| 22.7                       | ON           | ON           | ON           | ON           |
| 45.4                       | ON           | ON           | ON           | OFF          |
| 90.7                       | ON           | ON           | OFF          | OFF          |
| 181.6                      | ON           | OFF          | OFF          | OFF          |
| 302.9                      | OFF          | OFF          | OFF          | OFF          |

# 3 - INSTALLATION GUIDELINES

## 3.1 PERMISSIBLE AMBIENT CONDITION

|                    |           |  |
|--------------------|-----------|--|
| Protection degree: |           | IP 20 at operating temperatures of 32-131° F (0 ... 55° C).<br>UL enclosure type 1.<br>(American size) The converter must be installed in a pollution degree 2 environment.                |
| Altitude:          |           | Up to 3300 feet (1000 m) above sea level; higher altitudes a current reduction of 1.2 % for every 330 feet (100 m) of additional altitude.   |
| Temperature :      | Operation | Ambient temperature = 32-131° F (0 ... 55° C).<br>Over 104° F (40 °C): current reduction of 1.25 % for every 1.8 ° F over 104° F (1 °C over 40 °C) better than the 3K3 class per EN 50178) |
|                    | Storage   | Ambient temperature = -13° F ... 131° F (-25 ... +55° C)<br>(1K4 class as per EN 50178)<br>Ambient temperature = -4° F ... 131° F (-20 ... +55° C) for devices with keypad                 |
|                    | Transport | Ambient temperature = -13° F ... 131° F (-25 ... +55° C)<br>(2K3 class as per EN 50178)<br>Ambient temperature = -4° F ... 140° F (-20 ... +60° C) for devices with keypad                 |
| Air humidity:      | Operation | 5% up to 85%, 1 g/m <sup>3</sup> up to 25 g/m <sup>3</sup> without moisture condensation or icing<br>(3K3 class as per EN 50178)   |
|                    | Storage   | 5% up to 95%, 1 g/m <sup>3</sup> up to 29 g/m <sup>3</sup><br>(1K3 class as per EN 50178)  |
|                    | Transport | 95% 1)<br>60 g/m 2)<br>A light condensation of moisture may occur for a short time occasionally when the device is not in operation.<br>(2K3 class as per EN 50178)                        |
| Air pressure:      | Operation | From 86 kPa up to 106 kPa ( 3K3 class per EN 50178 )   |
|                    | Storage   | From 86 kPa up to 106 kPa ( 1K4 class per EN 50178 )   |
|                    | Transport | From 70 kPa up to 106 kPa ( 2K3 class per EN 50178 )   |

- 1) Greatest relative air humidity occurs with the temperature 104° F (40° C) or if the temperature of the device is brought immediately from -13° F ... 86° F (-25° C to +30° C).
- 2) Greatest absolute air humidity if the device is brought immediately from 158° F ... 59° F (70° C to +15° C).

### 3.2 DISPOSAL OF THE DEVICE

The converters of the TPD32 series can be disposed as electronic scraps in accordance with the currently valid national regulations for the disposal of electronic parts.

The plastic covering of the converters up to type 185 A are recyclable: the material used is >ABS+PC< “-FR”

### 3.3 MOUNTING THE DEVICE

**Note!**

The dimensions and weights specified in this manual should be taken into consideration when the device is mounted. The technical equipment required (carriage or crane for large weights) should be used. Improper handling and the use of unsuitable tools may cause damage.

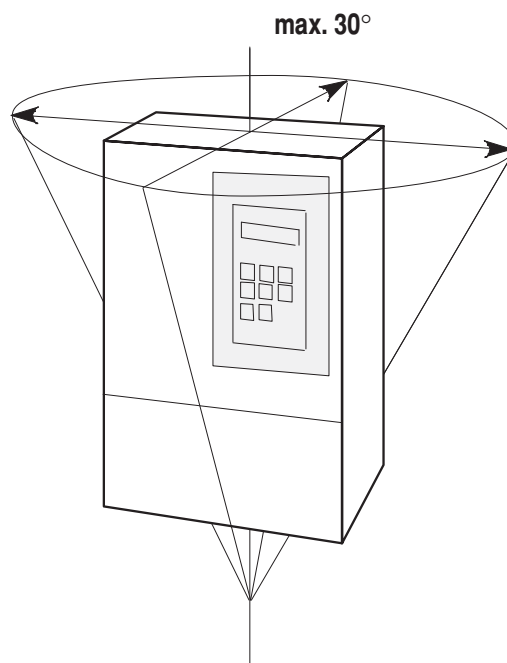

Figure 3.3.1: max Angle of Inclination

The maximum angle of inclination is 30°.

The converters must be mounted in such a way that the free flow of air is ensured.

The clearance to the device must be at least 6 inches (150 mm).

A space of at least 2 inches (50 mm) must be ensured at the front.

Devices that generate a large amount of heat must not be mounted in the direct vicinity of the frequency inverter.

**Note!**

Mounting screws should be re-tightened after a few days of operation.

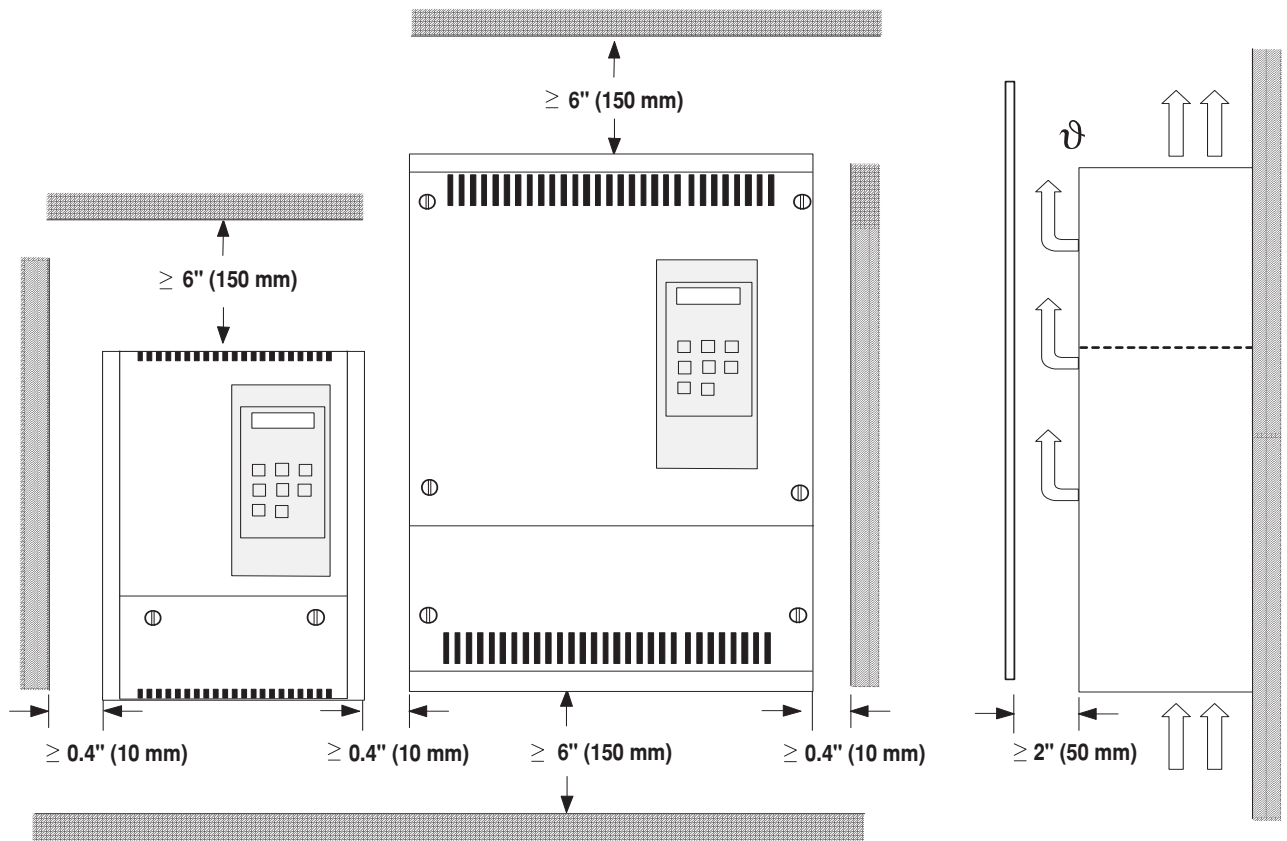

Figure 3.3.2: Mounting Clearance



# 4 - WIRING PROCEDURES

## 4.1 REMOVING THE FRONT COVER

The front cover of the device must be removed to make the electrical connections and to mount the option card.

**Warning!** Observe the safety instructions and warnings given in this manual. The devices can be opened without the use of force. Only use the tools specified.

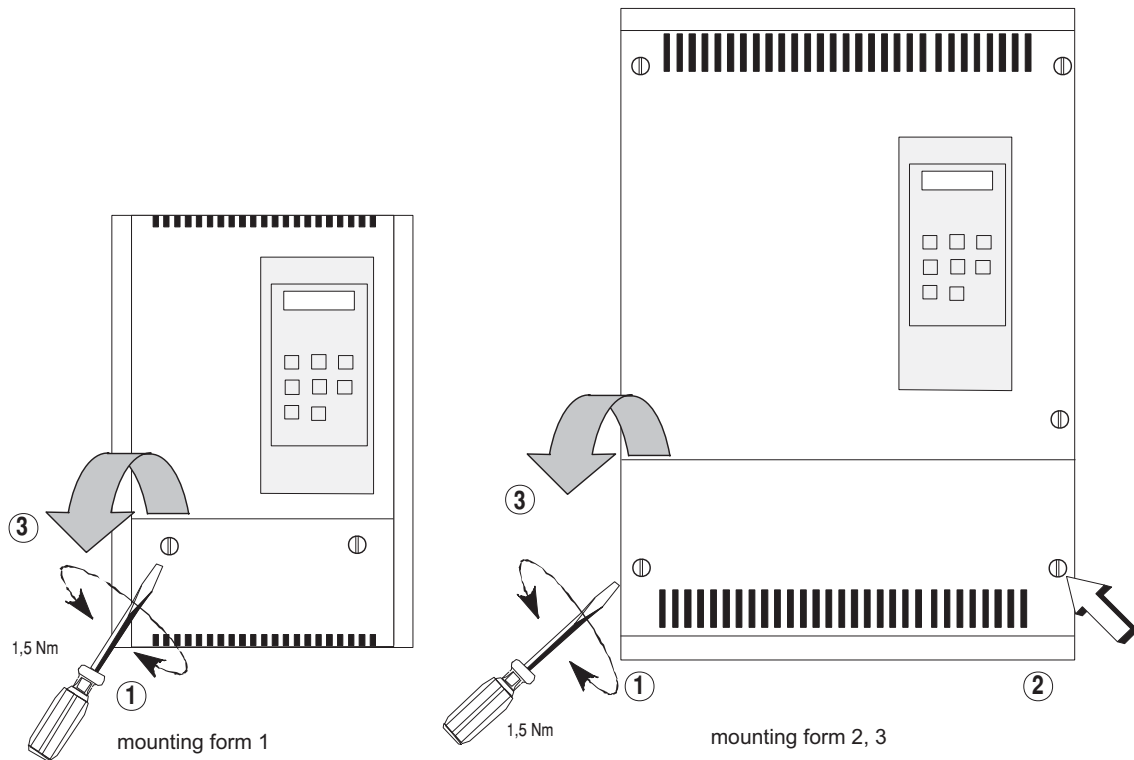

Figure 4.1.1: Removing the Front Panel

To remove the lower cover of devices, use a phillips screwdriver. Remove the screws, lift cover, and open out to the front.

### Terminal Assignments/Cable Sections

The terminals of the devices are made accessible by removing the front cover.

## 4.2 WIRING THE DRIVE

Wire the drive in accordance with the standard connection diagrams, Figures 4.8.1 and 4.8.2.

## 4.3 POWER SECTION

**Note!**

Use copper conductors only.

For UL listed equipments use 75°C stranded copper conductors only.

*Table 4.3.1: Terminals description*

| Designation | Function  | I/O | max voltage                      | max current |
|-------------|---|-----|----------------------------------|-------------|
| U, V, W     | Connection to the AC mains of the armature circuit  | I   | 500V<br>AC +10%, 3Ph             | see 2.4.2   |
| C, D        | Armature connection   | O   | see 00                           | see 2.4.3   |
| U1, V1      | Connection to the AC mains of the field circuit   | I   | 460V<br>AC + 15%, 1Ph            | see 2.4.2   |
| C1, D1      | Field connection  | O   | 0.87 x AC line volts             | see 2.4.3   |
| U2, V2      | AC power supply regulation  | I   | 115V -10%, 1Ph<br>230V +10%, 1Ph | see 2.4.2   |
| U3, V3      | AC mains power supply for internal fan<br>(for types with armature current = 560A American)<br>(for types with armature current = 770A European)  | I   | 230V<br>AC, 1Ph                  | 1A          |
| 35 / 36     | Contact without potential of OK relay (closed = OK),<br>function as per the OK relay func parameter<br>in the CONFIGURATION / digital output menu | O   | 250 VAC                          | 1 A AC11    |
| 75 / 76     | Contact without potential of relay 2,<br>function as per Relay 2 parameter in the<br>I/O CONFIGURATION / digital outputs menu                     | O   | 250 VAC                          | 1 A AC11    |
| 78 / 79     | Thermistor connection   | I   | —                                | —           |
| 81 / 82     | Internal fuses intervention signalling<br>(sizes ≥ TPD32-.../...-560-.. / TPD32-.../...-770-..)   | O   | 250 VAC                          | 1 A AC11    |

*Table 4.3.2: Cable size for power terminals U, V, W, C, D, PE*

| American             | European              | max cable section [mm <sup>2</sup> ]          | AWG                   | Tightening torque [Nm] |
|----------------------|-----------------------|---|-----------------------|------------------------|
| TPD32-.../...-17-..  | TPD32-.../...-20-..   | ...4  | ...12                 | 2...3                  |
| TPD32-.../...-35-..  | TPD32-.../...-40-..   | ...10   | ...8                  | 2.5...3                |
| TPD32-.../...-56-..  | TPD32-.../...-70-..   | ...16   | ...6                  |                        |
| TPD32-.../...-88-..  | TPD32-.../...-110-..  | 6...50  | 10...1                | 12                     |
| TPD32-.../...-112-.. | TPD32-.../...-140-..  | 16...95                                       | 6...000               |                        |
| TPD32-.../...-148-.. | TPD32-.../...-185-..  |   | Cu-Band 10 x 16 x 0.8 |                        |
| TPD32-.../...-224-.. | TPD32-.../...-280-..  |   |                       |                        |
| TPD32-.../...-280-.. | TPD32-.../...-350-..  |   |                       |                        |
| TPD32-.../...-336-.. | TPD32-.../...-420-..  |   |                       |                        |
| TPD32-.../...-400-.. | TPD32-.../...-500-..  | Cu-Band 11 x 21 x 1                           |                       | 20...25                |
| TPD32-.../...-450-.. | TPD32-.../...-650-..  |   |                       |                        |
| TPD32-.../...-560-.. | TPD32-.../...-770-..  | Cu-Band 50 x 8 or<br>2x Cu-Band 10 x 16 x 0.8 |                       |                        |
| TPD32-.../...-800-.. | TPD32-.../...-1000-.. | Cu-Band 50 x 8 or<br>2x Cu-Band 11 x 21 x 1   |                       |                        |
| TPD32-.../...-850-.. | TPD32-.../...-1050-.. |   |                       |                        |



Table 4.3.3: Cable section for UL approval

| Device type           | Terminals | Wire<br>AWG / kcmils  | Terminal bolt<br>metric size [mm] | Tightening<br>torque [Nm] |
|-----------------------|-----------|-----------------------|-----------------------------------|---------------------------|
| TPD32-.../...-20-..   | U, V, W   | 10                    | 5                                 | 6                         |
|                       | C, D      | 10                    | 5                                 | 6                         |
|                       | PE        | 10                    | 5                                 | 6                         |
| TPD32-.../...-40-..   | U, V, W   | 8                     | 5                                 | 6                         |
|                       | C, D      | 8                     | 5                                 | 6                         |
|                       | PE        | 8                     | 5                                 | 6                         |
| TPD32-.../...-70-..   | U, V, W   | 4                     | 5                                 | 6                         |
|                       | C, D      | 4                     | 5                                 | 6                         |
|                       | PE        | 4                     | 5                                 | 6                         |
| TPD32-.../...-110-..  | U, V, W   | 1/0                   | terminal block                    | 12                        |
|                       | C, D      | 1/0                   | terminal block                    | 12                        |
|                       | PE        | 2                     | terminal block                    | 12                        |
| TPD32-.../...-140-..  | U, V, W   | 2/0                   | terminal block                    | 12                        |
|                       | C, D      | 2/0                   | terminal block                    | 12                        |
|                       | PE        | 2                     | terminal block                    | 12                        |
| TPD32-.../...-185-..  | U, V, W   | 3/0                   | terminal block                    | 12                        |
|                       | C, D      | 4/0; kit required     | terminal block                    | 12                        |
|                       | PE        | 2                     | terminal block                    | 12                        |
| TPD32-.../...-280-..  | U, V, W   | 2 x 2/0               | 10                                | 50                        |
|                       | C, D      | 2 x 2/0               | 10                                | 50                        |
|                       | PE        | 2/0                   | 8                                 | 25                        |
| TPD32-.../...-350-..  | U, V, W   | 2 x 4/0               | 10                                | 50                        |
|                       | C, D      | 2 x 4/0               | 10                                | 50                        |
|                       | PE        | 2/0                   | 8                                 | 25                        |
| TPD32-.../...-420-..  | U, V, W   | 2 x 4/0               | 10                                | 50                        |
|                       | C, D      | 2 x 300               | 10                                | 50                        |
|                       | PE        | 2/0                   | 8                                 | 25                        |
| TPD32-.../...-500-..  | U, V, W   | 2 x 300; kit required | 10                                | 50                        |
|                       | C, D      | 2 x 350; kit required | 10                                | 50                        |
|                       | PE        | 2/0                   | 8                                 | 25                        |
| TPD32-.../...-650-..  | U, V, W   | 2 x 500; kit required | 10                                | 50                        |
|                       | C, D      | 2 x 600; kit required | 10                                | 50                        |
|                       | PE        | 2/0                   | 8                                 | 25                        |
| TPD32-.../...-770-..  | U, V, W   | 4 x 4/0               | 10                                | 50                        |
|                       | C, D      | 4 x 250               | 10                                | 50                        |
|                       | PE        | 2/0                   | 8                                 | 25                        |
| TPD32-.../...-1000-.. | U, V, W   | 4 x 300; kit required | 10                                | 50                        |
|                       | C, D      | 4 x 350; kit required | 10                                | 50                        |
|                       | PE        | 2/0                   | 8                                 | 25                        |
| TPD32-.../...-1050-.. | U, V, W   | 4 x 300; kit required | 10                                | 50                        |
|                       | C, D      | 4 x 400; kit required | 10                                | 50                        |
|                       | PE        | 2/0                   | 8                                 | 25                        |

The following sizes are not provided with pressure connectors. Recommended compression lugs are in the following table. For sizes up to 56A any UL listed lug, sized for the indicated bolt and AWG cable, is suitable for this use, otherwise a compression lug type from ILSCO manufacturer is specified.

| Device type          | AWG     | Lug type              | Bolt diameter [mm] | Tightening torque [Nm] |
|----------------------|---------|-----------------------|--------------------|------------------------|
| TPD32-.../...-17-..  | 12      | any                   | 5                  | 2-3                    |
| TPD32-.../...-35-..  | 8       | any                   | 5                  | 2.5-3                  |
| TPD32-.../...-56-..  | 4       | any                   | 5                  | 2.5-3                  |
| TPD32-.../...-224-.. | 2 x 1/0 | CCL-1/0-12            | 10.5               | 20-25                  |
|                      | 1 x 300 | CRA-300               | 10.5               | 20-25                  |
| TPD32-.../...-280-.. | 2 x 2/0 | CCL-2/0-12            | 10.5               | 20-25                  |
| TPD32-.../...-336-.. | 2 x 4/0 | CRB-4/0 or CCL-4/0-12 | 10.5               | 20-25                  |
| TPD32-.../...-400-.. | 2 x 250 | CRA-250 or CRA-250L   | 10.5               | 20-25                  |
| TPD32-.../...-450-.. | 2 x 300 | CRA-300 or CRA-300L   | 10.5               | 20-25                  |
| TPD32-.../...-560-.. | 4 x 4/0 | CCL-4/0-12            | 10.5               | 20-25                  |
| TPD32-.../...-800-.. | 4 x 250 | CRA-250 or CRA-250L   | 10.5               | 20-25                  |
| TPD32-.../...-850-.. | 4 x 300 | CRA-300 or CRA-300L   | 10.5               | 20-25                  |

In the table above 2X... means that two compression lugs of the specified type have to be used on the opposite side of the busbar. 4X... means that four compression lugs of the specified type have to be used on the same busbar, two for each side and one for each bolt hole.

Bolt, nuts and washers are factory mounted on output busbars. The required ILSCO compression tool is marked on each terminal plug.

For sizes above 112A the front terminal cover has to be removed when using the above listed lugs.

The following sizes are provided with terminal blocks:

U/V/W/C/D: AWG 5-3/0(16-95mm<sup>2</sup>), stranded Cu

PE: AWG 5-1(16-50mm<sup>2</sup>), stranded Cu

The following AWG and torque are required for field wiring:

| Device               | AWG | Tightening torque [Nm] |
|----------------------|-----|------------------------|
| TPD32-.../...-88-..  | 2   | 12                     |
| TPD32-.../...-112-.. | 1/0 | 12                     |
| TPD32-.../...-148-.. | 3/0 | 12                     |
| ground               | -   | 12                     |

**Note!** When connecting the converter, a 9.5 mm (3/8 in.) spacing between uninsulated live parts of opposite polarity should be maintained.

**Note!** The TPD32 converters are UL listed only when used with the above mentioned terminal kits.

*Table 4.3.4: Wire adapter Kit and lugs suggested for UL approval*

| Device type           | Terminals | Wire adapter kit |                    |                        | Recommended lugs    |             |
|-----------------------|-----------|------------------|--------------------|------------------------|---------------------|-------------|
|                       |           | type             | Kit bolt size [mm] | Tightening torque [Nm] | ILSCO type          | Burndy type |
| TPD32-.../...-185-..  | U, V, W   | -                | -                  | -                      | -                   | -           |
|                       | C, D      | EAM 1578         | 8                  | 25                     | CCL-4/0-516         | YA28-L3     |
|                       | PE        | -                | -                  | -                      | -                   | -           |
| TPD32-.../...-280-..  | U, V, W   | -                | -                  | -                      | CCL-2/0-12          | YA26-L6BOX  |
|                       | C, D      | -                | -                  | -                      | CCL-2/0-12          | YA26-L6BOX  |
|                       | PE        | -                | -                  | -                      | CRA-2/0, CCL-2/0-38 | YA26-LBOX   |
| TPD32-.../...-350-..  | U, V, W   | -                | -                  | -                      | CCL-4/0-12          | YA28-LBOX   |
|                       | C, D      | -                | -                  | -                      | CCL-4/0-12          | YA28-LBOX   |
|                       | PE        | -                | -                  | -                      | CRA-2/0, CCL-2/0-38 | YA26-LBOX   |
| TPD32-.../...-420-..  | U, V, W   | -                | -                  | -                      | CCL-4/0-12          | YA28-LBOX   |
|                       | C, D      | -                | -                  | -                      | CRA-300, CRA-300L   | YA30-L      |
|                       | PE        | -                | -                  | -                      | CRA-2/0, CCL-2/0-38 | YA26-LBOX   |
| TPD32-.../...-500-..  | U, V, W   | EAM 1579         | 10                 | 50                     | -                   | YA30-L      |
|                       | C, D      | -                | 10                 | 50                     | -                   | YA31-L      |
|                       | PE        | -                | -                  | -                      | CRA-2/0, CCL-2/0-38 | YA26-LBOX   |
| TPD32-.../...-650-..  | U, V, W   | EAM 1580         | 14                 | 140                    | -                   | YA34-L      |
|                       | C, D      | -                | 14                 | 140                    | -                   | YA36-L      |
|                       | PE        | -                | -                  | -                      | CRA-2/0, CCL-2/0-38 | YA26-LBOX   |
| TPD32-.../...-770-..  | U, V, W   | -                | -                  | -                      | CCL-4/0-12          | YA28-LBOX   |
|                       | C, D      | -                | -                  | -                      | CRA-250, CRA-250L   | YA29-LBOX   |
|                       | PE        | -                | -                  | -                      | CRA-2/0, CCL-2/0-38 | YA26-LBOX   |
| TPD32-.../...-1000-.. | U, V, W   | EAM 1581         | 10                 | 50                     | -                   | YA30-L      |
|                       | C, D      | -                | 10                 | 50                     | -                   | YA31-L      |
|                       | PE        | -                | -                  | -                      | CRA-2/0, CCL-2/0-38 | YA26-LBOX   |
| TPD32-.../...-1050-.. | U, V, W   | EAM 1581         | 10                 | 50                     | -                   | YA30-L      |
|                       | C, D      | -                | 10                 | 50                     | -                   | YA32-L1     |
|                       | PE        | -                | -                  | -                      | CRA-2/0, CCL-2/0-38 | YA26-LBOX   |

**Note!** The cable cross section to be connected must be dimensioned and determined by the designer that has to take into account the current, the temperature and the cable position. The values indicated on the table are referred to the maximum cross section accepted by its terminals; they are not the indication about the cable dimension to be connected!

**Caution!** The current in the protective conductor of the motor cable can be up to twice the value of the rated current if there is an earth fault at the output of the TPD32 converter.

Table 4.3.5: Cable size for power field terminals U1, V1, C1, D1

| American             | European              | max cable section<br>[mm <sup>2</sup> ] | AWG     | Tightening torque<br>[Nm] |
|----------------------|-----------------------|---|---------|---------------------------|
| TPD32-.../...-17-..  | TPD32-.../...-20-..   | 0.2...4                                 | 24...10 | 0.5...0.8                 |
| TPD32-.../...-35-..  | TPD32-.../...-40-..   |   |         |                           |
| TPD32-.../...-56-..  | TPD32-.../...-70-..   |   |         |                           |
| TPD32-.../...-88-..  | TPD32-.../...-110-..  |   |         |                           |
| TPD32-.../...-112-.. | TPD32-.../...-140-..  |   |         |                           |
| TPD32-.../...-148-.. | TPD32-.../...-185-..  |   |         |                           |
| TPD32-.../...-224-.. | TPD32-.../...-280-..  |   |         |                           |
| TPD32-.../...-280-.. | TPD32-.../...-350-..  |   |         |                           |
| TPD32-.../...-336-.. | TPD32-.../...-420-..  |   |         |                           |
| TPD32-.../...-400-.. | TPD32-.../...-500-..  |   |         |                           |
| TPD32-.../...-450-.. | TPD32-.../...-650-..  |   |         |                           |
| TPD32-.../...-560-.. | TPD32-.../...-770-..  |   |         |                           |
| TPD32-.../...-800-.. | TPD32-.../...-1000-.. |   |         |                           |
| TPD32-.../...-850-.. | TPD32-.../...-1050-.. |   |         |                           |

Table 4.3.6: Cable size for fans, signals, thermistors and regulation supply

| Terminals                              | Max connection cable section |                               |         | Tightening torque<br>[Nm] |
|--|------------------------------|-------------------------------|---------|---------------------------|
|  | flexible [mm <sup>2</sup> ]  | multi-core [mm <sup>2</sup> ] | AWG     |                           |
| PE                                     | 2.5...10                     | 2.5...10                      | 12...8  | 2                         |
| U2, U3, V2, V3, 35, 36, 75, 76, 78, 79 | 0.14...1.5                   | 0.14...2.5                    | 26...14 | 0.5                       |

## 4.4 REGULATION SECTION

The R-TPD32 Regulation card is factory set according to the device type. When fitting a regulator card as a spare, remember to set switch S15 (device type selection), S4 (tachometer feedback) and S14 (field current resistor selection) accordingly.

As for sizes above 850 / 1050 A (American / European) see “DC Drives with external bridge” Addendum.

### 4.4.1 R-TPD32 Regulation Card

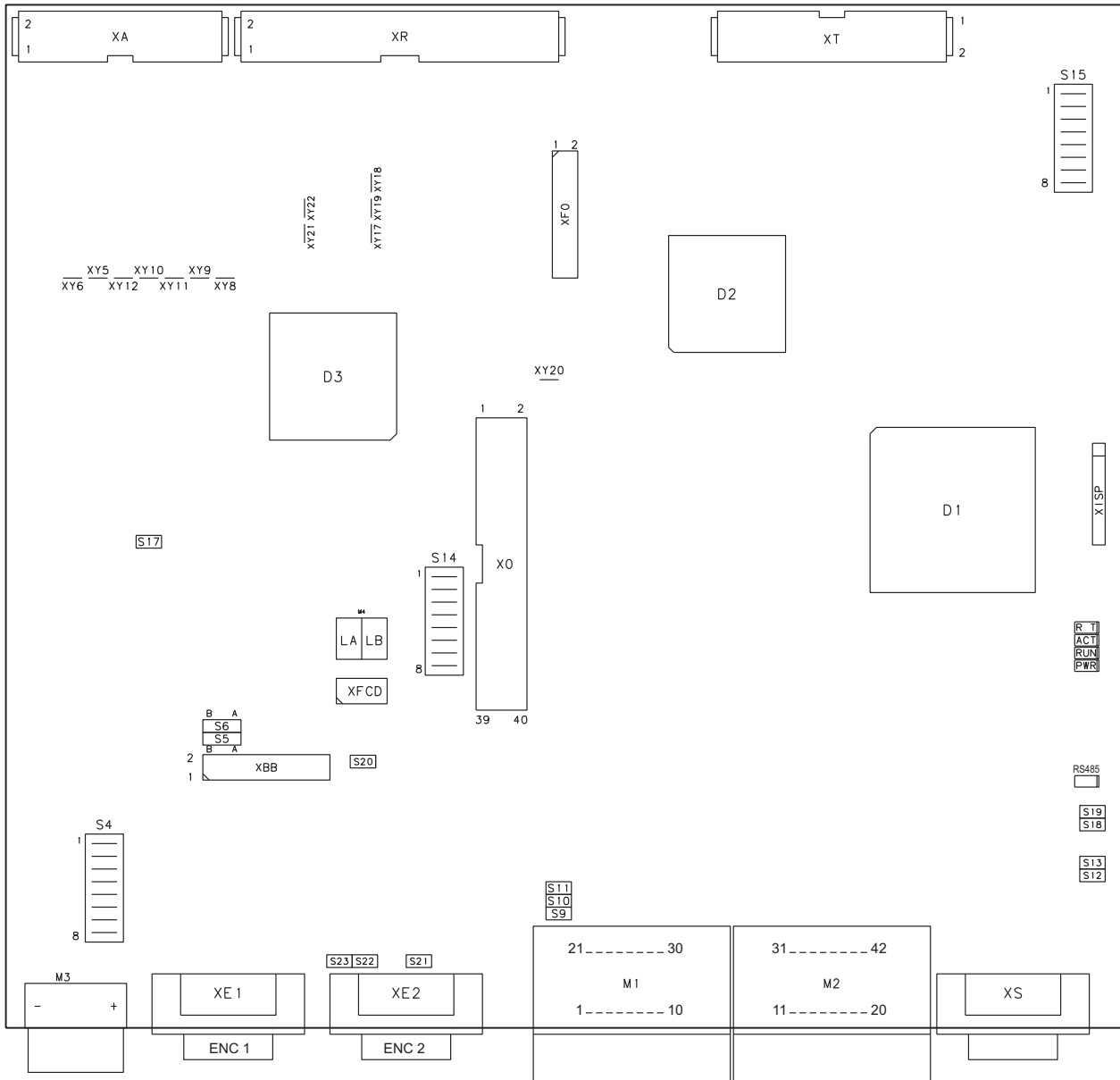

Figure 4.4.1: R-TPD32 regulation card

Table 4.4.1: LEDs on the R-TPD32 card

| Designation | Function   |
|-------------|--|
| PWR         | ON when the +5 V voltage is present at the right value |
| RST         | ON when the signal RST is active                       |
| RS485       | ON when the RS485 interface is supplied                |
| ACT         | It is lit when the SCR driving system is active        |
| RUN         | The LED blinks during the regulation phase             |

Table 4.4.2: Dip-switch S15 adaptation of the regulation card to the device type

| Converter type                                | S15-1 | S15-2 | S15-3 | S15-4 | S15-5 | S15-6 | S15-7 | S15-8 |
|---|-------|-------|-------|-------|-------|-------|-------|-------|
| TPD32-400/...-20-..<br>TPD32-400/...-17-..    | OFF   | OFF   | OFF   | OFF   | OFF   | OFF   | OFF   | OFF   |
| TPD32-400/...-40-..<br>TPD32-400/...-35-..    | ON    | OFF   | OFF   | OFF   | OFF   | OFF   | OFF   | OFF   |
| TPD32-400/...-70-..<br>TPD32-400/...-56-..    | OFF   | ON    | OFF   | OFF   | OFF   | OFF   | OFF   | OFF   |
| TPD32-400/...-110-..<br>TPD32-400/...-88-..   | ON    | ON    | OFF   | OFF   | OFF   | OFF   | OFF   | OFF   |
| TPD32-400/...-140-..<br>TPD32-400/...-112-..  | OFF   | OFF   | ON    | OFF   | OFF   | OFF   | OFF   | OFF   |
| TPD32-400/...-185-..<br>TPD32-400/...-148-..  | ON    | OFF   | ON    | OFF   | OFF   | OFF   | OFF   | OFF   |
| TPD32-400/...-280-..<br>TPD32-400/...-224-..  | OFF   | ON    | ON    | OFF   | OFF   | OFF   | OFF   | OFF   |
| TPD32-400/...-350-..<br>TPD32-400/...-280-..  | ON    | ON    | ON    | OFF   | OFF   | OFF   | OFF   | OFF   |
| TPD32-400/...-420-..<br>TPD32-400/...-336-..  | OFF   | OFF   | OFF   | ON    | OFF   | OFF   | OFF   | OFF   |
| TPD32-400/...-500-..<br>TPD32-400/...-400-..  | ON    | OFF   | OFF   | ON    | OFF   | OFF   | OFF   | OFF   |
| TPD32-400/...-650-..<br>TPD32-400/...-450-..  | OFF   | ON    | OFF   | ON    | OFF   | OFF   | OFF   | OFF   |
| TPD32-400/...-770-..<br>TPD32-400/...-560-..  | ON    | ON    | OFF   | ON    | OFF   | OFF   | OFF   | OFF   |
| TPD32-400/...-1000-..<br>TPD32-400/...-800-.. | OFF   | OFF   | ON    | ON    | OFF   | OFF   | OFF   | OFF   |
| TPD32-400/...-1050-..<br>TPD32-400/...-850-.. | OFF   | OFF   | ON    | ON    | OFF   | OFF   | OFF   | OFF   |

| Converter type                                | S15-1 | S15-2 | S15-3 | S15-4 | S15-5 | S15-6 | S15-7 | S15-8 |
|---|-------|-------|-------|-------|-------|-------|-------|-------|
| TPD32-500/...-20-..<br>TPD32-500/...-17-..    | OFF   | OFF   | OFF   | OFF   | OFF   | OFF   | ON    | OFF   |
| TPD32-500/...-40-..<br>TPD32-500/...-35-..    | ON    | OFF   | OFF   | OFF   | OFF   | OFF   | ON    | OFF   |
| TPD32-500/...-70-..<br>TPD32-500/...-56-..    | OFF   | ON    | OFF   | OFF   | OFF   | OFF   | ON    | OFF   |
| TPD32-500/...-110-..<br>TPD32-500/...-88-..   | ON    | ON    | OFF   | OFF   | OFF   | OFF   | ON    | OFF   |
| TPD32-500/...-140-..<br>TPD32-500/...-112-..  | OFF   | OFF   | ON    | OFF   | OFF   | OFF   | ON    | OFF   |
| TPD32-500/...-185-..<br>TPD32-500/...-148-..  | ON    | OFF   | ON    | OFF   | OFF   | OFF   | ON    | OFF   |
| TPD32-500/...-280-..<br>TPD32-500/...-224-..  | OFF   | ON    | ON    | OFF   | OFF   | OFF   | ON    | OFF   |
| TPD32-500/...-350-..<br>TPD32-500/...-280-..  | ON    | ON    | ON    | OFF   | OFF   | OFF   | ON    | OFF   |
| TPD32-500/...-420-..<br>TPD32-500/...-336-..  | OFF   | OFF   | OFF   | ON    | OFF   | OFF   | ON    | OFF   |
| TPD32-500/...-500-..<br>TPD32-500/...-400-..  | ON    | OFF   | OFF   | ON    | OFF   | OFF   | ON    | OFF   |
| TPD32-500/...-650-..<br>TPD32-500/...-450-..  | OFF   | ON    | OFF   | ON    | OFF   | OFF   | ON    | OFF   |
| TPD32-500/...-770-..<br>TPD32-500/...-560-..  | ON    | ON    | OFF   | ON    | OFF   | OFF   | ON    | OFF   |
| TPD32-500/...-1000-..<br>TPD32-500/...-800-.. | OFF   | OFF   | ON    | ON    | OFF   | OFF   | ON    | OFF   |
| TPD32-500/...-1050-..<br>TPD32-500/...-850-.. | OFF   | OFF   | ON    | ON    | OFF   | OFF   | ON    | OFF   |

Table 4.4.3 : Dip-switch S4 adaptation of the tachometer feedback to the input voltage

| Tacho voltage full scale (V) | S4-1<br>S4-8 | S4-2<br>S4-7 | S4-3<br>S4-6 | S4-4<br>S4-5 |
|------------------------------|--------------|--------------|--------------|--------------|
| 22.7                         | ON           | ON           | ON           | ON           |
| 45.4                         | ON           | ON           | ON           | OFF          |
| 90.7                         | ON           | ON           | OFF          | OFF          |
| 181.6                        | ON           | OFF          | OFF          | OFF          |
| 302.9                        | OFF          | OFF          | OFF          | OFF          |

Table 4.4.4: Jumpers on the R-TPD32 card

| Designation     | Function  | Factory |
|-----------------|---|---------|
| S4              | Matching of the input voltage of the tachogenerator reaction, see table 4.4.3   |         |
| S5,S6           | Adaptation of the speed feedback type:<br>Pos. A Sinusoidal encoder<br>Pos. B Tachogenerator<br>Any position: digital encoder, armature feedback  | B       |
| S9              | Adaptation to the signal of the analog input Input 1 (terminals 1 and 2)<br>ON 0 ... 20 mA / 4 ... 20 mA<br>OFF 0 ... 10V / -10 ... +10V  | OFF     |
| S10             | Adaptation to the signal of the analog input Input 2 (terminal 3 and 4)<br>ON 0 ... 20 mA / 4 ... 20 mA<br>OFF 0 ... 10V / -10 ... +10V   | OFF     |
| S11             | Adaptation to the signal of the analog Input 3 (terminals 5 and 6)<br>ON 0 ... 20 mA / 4 ... 20 mA<br>OFF 0 ... 10V / -10 ... +10V  | OFF     |
| S12 / S13       | Terminating resistor for the serial interface RS485<br>ON Interface terminated with resistor<br>OFF Interface not terminated  | OFF     |
| S14             | Field current resistors setting, see table 2.4.3.2  |         |
| S15             | Adaptation of the regulation card to the device type, see table 4.4.2   |         |
| S18 / S19       | Selection of the internal/external supply of the RS485 serial interface<br>OFF Serial interface supplied from the outside (PIN 5 and 9) and galvanic divided form the regulation section.<br>ON Serial interface supplied from the inside and connected to the potential reference point of the regulation. PIN 5 and 9 are used to supply the adaptor of the serial interface. | OFF     |
| S20             | Monitoring of the C channel of the digital encoder on connector XE2<br>ON C-channel monitored<br>OFF C-channel not monitored  | OFF     |
| S21 / S22 / S23 | Encoder supply voltage selection<br>ON 5 V encoder supply voltage<br>OFF 15...30 V encoder supply voltage   | OFF     |

ON Mounted Jumpers

OFF Non mounted Jumpers

Table 4.4.5: Test points on Regulator card

| Designation | Function  | Designation | Function  |
|-------------|---|-------------|---|
| XY20        | Monitoring ( $\pm 10$ VDC) of the Select output parameters setting.<br>(Using this test point set all the Select output 1,2,3,4 to the variable that has to be measured). | XY17        | Output current signal<br>(0.61 V =Nominal Drive output current) |
| XY10        | Reference point   | XY18        | Reference point   |

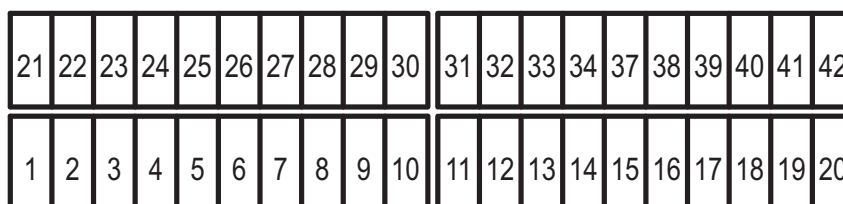

Figure 4.4.2: Disposition of terminals from 1 to 42

Table 4.4.6 - A: Terminal Assignment (terminals from 1 to 20)

| Terminal Designation   | Function  | I/O | Max voltage | Max current                            |
|------------------------|---|-----|-------------|--|
| 1 +2<br>Analog input 1 | Configurable analog differential input<br>Signal: Term. 1, Reference point Term. 2<br>Factory set for Ramp ref 1* | I   | ±10V        | 0.25mA<br>(20mA at current ref. value) |
| 3 +4<br>Analog input 2 | Configurable analog differential input<br>Signal: Term. 3, Reference point Term. 4<br>Not factory set             | I   | ±10V        | 0.25mA<br>(20mA at current ref. value) |
| 5 +6<br>Analog input 3 | Configurable analog differential input<br>Signal: Term. 5, Reference point Term. 6<br>Not factory set             | I   | ±10V        | 0.25mA<br>(20mA at current ref. value) |
| 7<br>+10V              | Reference voltage +10V<br>Reference point: Term. 9  | O   | +10V        | 10mA                                   |
| 8<br>-10V              | Reference voltage -10V<br>Reference point: Term. 9  | O   | -10V        | 10mA                                   |
| 9<br>0V 10             | Reference point for the reference voltages on terminal 7 and 8  | —   | —           | —                                      |
| 10                     | Screen connection (PE) (connected with housing)   | —   | —           | —                                      |
| 11                     | Internal 0V   | —   | —           | —                                      |
| 12<br>Enable drive     | Converter enable<br>0V Disabled converter<br>+15...30V Enabled converter  | I   | +30V        | 15V/3.2mA<br>24V/5mA<br>30V/6.4mA      |
| 13<br>Start            | Start command<br>0V No start command<br>+15...30V Start   | I   | +30V        | 15V/3.2mA<br>24V/5mA<br>30V/6.4mA      |
| 14<br>Fast stop        | Fast stop<br>0V Fast stop<br>+15...30V No Fast stop   | I   | +30V        | 15V/3.2mA<br>24V/5mA<br>30V/6.4mA      |
| 15<br>External fault   | External fault<br>0V External fault present<br>+15...30V No external fault present                                | I   | +30V        | 15V/3.2mA<br>24V/5mA<br>30V/6.4mA      |
| 16<br>COM ID           | Reference point of the digital inputs, terminals 12 to 15   | —   | —           | —                                      |
| 18<br>0V 24            | Reference point of the 24V voltage on terminal 19   | —   | —           | —                                      |
| 19<br>+24 V            | Voltage +24V<br>Reference point Terminal 18   | O   | +20...30V   | 200 mA**                               |
| 20                     | Screen connection (PE) (connected w/housing)  | —   | —           | —                                      |

\* The user can adapt the configuration to the requirements of the application concerned via the keypad, the serial interface or a bus connection.

\*\* Total value including Terminal 19, Pin 2 of connector XE2 and the digital outputs on the TBO option card.

From the R-TPD32 regulation card, a TBO card has been integrated on the regulation section (terminals from 21 to 42). The integrated card is considered by the device as TBO "A".

*Table 4.4.6 - B: Terminal Assignment (terminals from 21 to 42)*

| Designation                 | Function   | I/O | Max voltage | Max current                       |
|-----------------------------|--|-----|-------------|-----------------------------------|
| 21<br>Analog out 1          | Analog output 1<br>Reference point: Terminal 22<br>Factory set for Actual speed  | O   | ±10V        | 5mA                               |
| 22<br>COM analog output 1   | Reference point of analog output 1   | —   | —           | —                                 |
| 23<br>Analog out 2          | Analog output 2<br>Reference point: Terminal 24<br>Factory set for Motor current | O   | ±10V        | 5mA                               |
| 24<br>COM analog output 2   | Reference of analog output 2   | —   | —           | —                                 |
| 25<br>COM digital outputs   | COM digital outputs (Terminals 26...29)  | —   | —           | —                                 |
| 26<br>Digital output 1      | Digital output 1<br>COM: Terminal 25<br>Factory set for Ramp +                   | O   | +30V        | 50mA                              |
| 27<br>Digital output 2      | Digital output 2<br>COM: Terminal 25<br>Factory set for Ramp -                   | O   | +30V        | 50mA                              |
| 28<br>Digital output 3      | Digital output 3<br>COM: Terminal 25<br>Factory set for Spd threshold            | O   | +30V        | 50mA                              |
| 29<br>Digital output 4      | Digital output 4<br>COM: Terminal 25<br>Factory set for Overload available       | O   | +30V        | 50mA                              |
| 30<br>Supply digital output | Supply voltage for digital outputs   | I   | +30V        | depends on the load<br>max 80mA   |
| 31<br>Digital input 1       | Digital input 1<br>COM: Terminal 37<br>Not Factory set                           | I   | +30V        | 15V/3.2mA<br>24V/5mA<br>30V/6.4mA |
| 32<br>Digital input 2       | Digital input 2<br>COM: Terminal 37<br>Not Factory set                           | I   | +30V        | 15V/3.2mA<br>24V/5mA<br>30V/6.4mA |
| 33<br>Digital input 3       | Digital input 3<br>COM: Terminal 37<br>Not Factory set                           | I   | +30V        | 15V/3.2mA<br>24V/5mA<br>30V/6.4mA |
| 34<br>Digital input 4       | Digital input 4<br>COM: Terminal 37<br>Not Factory set                           | I   | +30V        | 15V/3.2mA<br>24V/5mA<br>30V/6.4mA |
| 37<br>COM digital inputs    | COM of the digital inputs (Terminals 31...34)                                    | —   | —           |                                   |
| 38 ... 42                   | Not used   |     |             |                                   |



Table 4.4.7: Cable size for fans, signals, and thermistors

| Terminals    | Max connection cable section |                               |         | Tightening torque<br>[Nm] |
|--------------|------------------------------|-------------------------------|---------|---------------------------|
|              | flexible [mm <sup>2</sup> ]  | multi-core [mm <sup>2</sup> ] | AWG     |                           |
| 1...20, +, - | 0.14...1.5                   | 0.14...1.5                    | 26...16 | 0,4                       |

The use of a 3 x 0.1 x 0.02 inches (75 x 2.5 x 0.4 mm) flat screwdriver is recommended. Remove 0.26 inches (6.5mm) of the insulation at the cable ends. Only one unprepared wire (without ferrule) should be connected to each terminal.

Table 4.4.8: Terminal strip for the connection of an analog tachometer

| Designation | Function   | I/O | max volt.                                    | max curr. |
|-------------|--|-----|--|-----------|
| —           | Negative tachometer input  | I   | —  | —         |
| +           | Positive tachometer input<br>Clockwise rotation: positive /<br>counterclockwise: negative. | I   | 22.7 / 45.4 /<br>90.7 / 181.6 /<br>302.9 V * | 8 mA      |

\* It depends on the section set via the Dip switch S4 (see table 4.4.3).

Table 4.4.9: Assignment of an XE1 connector for a sinusoidal encoder

| Designation* | Function                            | I/O | max volt. | max curr. |
|--------------|-------------------------------------|-----|-----------|-----------|
| PIN 1        | Channel B-                          | I   | 1 V pp    | 8.3mA pp  |
| PIN 2        | Not connected                       |     |           |           |
| PIN 3        | Channel C+ (zero pulse)             | I   | 1 V pp    | 8.3mA pp  |
| PIN 4        | Channel C- (zero pulse)             | I   | 1 V pp    | 8.3mA pp  |
| PIN 5        | Channel A+                          | I   | 1 V pp    | 8.3mA pp  |
| PIN 6        | Channel A-                          | I   | 1 V pp    | 8.3mA pp  |
| PIN 7        | Reference point for 5V              | O   |           |           |
| PIN 8        | Channel B+                          | I   | 1 V pp    | 8.3mA pp  |
| PIN 9        | Supply voltage + 5V for the encoder | O   | +5 V      | 160mA     |

\* 9-pole socket connector, fitted on device. A plug connector according DIN 41 652 is required for the connection.

Table 4.4.10: Assignment of the XE2 connector for a digital encoder

| Designation* | Function                            | I/O | max volt. | max curr. |
|--------------|-------------------------------------|-----|-----------|-----------|
| PIN 1        | Channel B-                          | I   | 30 V pp** | 17mA pp   |
| PIN 2        | Supply voltage +24V for the encoder | O   | 24 V      | 200mA***  |
| PIN 3        | Channel C+ (zero pulse)             | I   | 30 V pp** | 17mA pp   |
| PIN 4        | Channel C- (zero pulse)             | I   | 30 V pp** | 17mA pp   |
| PIN 5        | Channel A+                          | I   | 30 V pp** | 17mA pp   |
| PIN 6        | Channel A-                          | I   | 30 V pp** | 17mA pp   |
| PIN 7        | Reference point for 24V             | O   | —         | —         |
| PIN 8        | Channel B+                          | I   | 30 V pp** | 17mA pp   |
| PIN 9        | Not connected                       | —   | —         | —         |

\* 9-pole socket connector, fitted on device. A plug connector acc. DIN 41 652 is required for the connection.

\*\* The max voltage is 30V when the S21, S22, S23 jumpers are not mounted (Encoder 15...30 V). If these jumpers are mounted the max voltage at these Pins is 5V!

\*\*\* Total value including Terminal 19, Pin 2 of connector XE2 and the digital outputs on the TBO option card.

## 4.5 SERIAL INTERFACE

### 4.5.1 Description

The RS 485 serial interface enables data transfer via a loop made of two symmetrical, spiral conductors with a common shield. The maximum transmission distance is 3936 feet (1200 m) with a transfer rate of 38,400 KBaud.

The transmission is carried out via a differential signal.

RS 485 interfaces are bus-compatible in half-duplex mode, i.e. sending and receiving take place in succession. Up to 31 TPD32 devices (up to 128 address selectable) can be networked together via the RS 485 interface.

Address setting is carried out via the **Device address** parameter. Further information concerning the parameters to be transferred, their type and value range is given in the table contained in section 10, "Parameter List" (RS485 column).

The RS 485 on the TPD32 series devices is located on the Regulation card in the form of a 9-pole SUB-D socket connector (XS). The communication may be with or without galvanic isolation: by using galvanic isolation an external power supply is necessary for +5V. The differential signal is transferred via PIN 3 (TxA/RxA) and PIN 7 (TxB/RxB). Bus terminating resistors must be connected at the physical beginning and end of an RS 485 bus in order to prevent signal reflexion. The bus terminating resistors on TPD32 series devices are connected via jumpers S12 and S13. This enables a direct point-to-point connection with a PLC or PC.

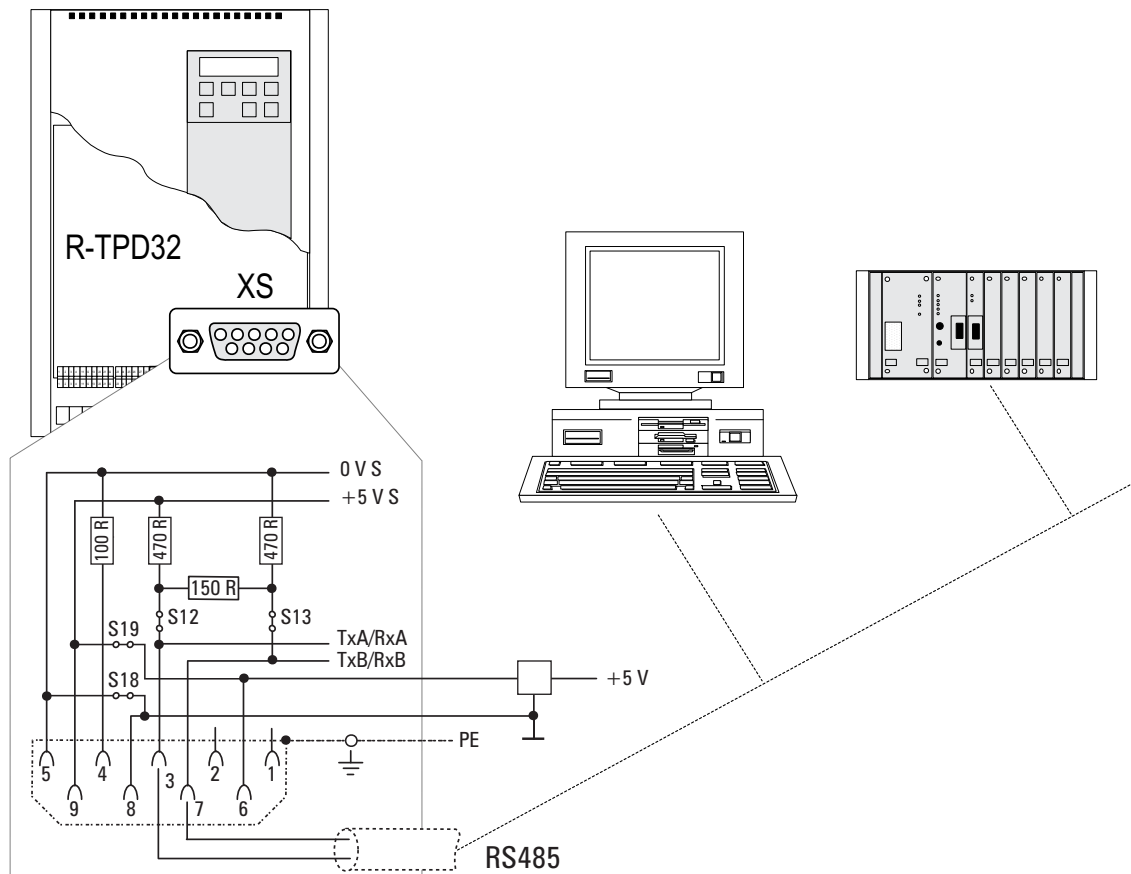

Figure 4.5.1.1: RS485 serial interface

**Note!** Ensure that only the first and last drop of an RS 485 bus have a bus terminating resistor (S12 and S13 mounted). In all other cases (within the line) jumpers S12 and S13 must not be mounted. With S18 and S19 mounted the drive supply the serial line. This modality is allowed on point-to-point connection without galvanic isolation only.

**Note!** A connection point to point can be done using “PCI-485” option interface (S18 and S19 mounted). For multidrop connection (two or more drive), an external power supply is necessary (pin 5 / 0V and pin 9 / +5V).

Pins 6 and 8 are reserved for use with the “PCI-485” interface card.

When connecting the serial interface ensure that:

- only shielded cables are used
- power cables and control cables for contactors/relays are routed separately.

## 4.5.2 RS485 serial interface connector description

Table 4.5.2.1: Description of the XS connector for the RS485 serial interface

| Designation* | Function                 | I/O | Elec. Interface |
|--------------|--------------------------|-----|-----------------|
| PIN 1        | Internal use             |     |                 |
| PIN 2        | Internal use             |     |                 |
| PIN 3        | RxA/TxA                  | I/O | RS485           |
| PIN 4        | Internal use             |     |                 |
| PIN 5        | 0 V (reference point 5V) |     | Power supply    |
| PIN 6        | Internal use             |     |                 |
| PIN 7        | RxB/TxB                  | I/O | RS485           |
| PIN 8        | Internal use             |     |                 |
| PIN 9        | +5V                      |     | Power supply    |

\* 9-pole socket connector, fitted on device. A plug connector acc. DIN 41 652 is required for the connection

The pin 5 and 9 function depends on the position of the jumpers S18 and S19 which state if the serial line is divided or not from the converter reference potential.

S18 and S19 in position OFF      The serial interface is galvanic separated from the regulator section. The serial interface power supply is provided from the outside via the PIN 5 (0V) and PIN 9 (+5V) of the XS connector (default factory setting).

S18 and S19 in position ON      The serial interface has the same potential reference point as the regulator. The PIN 5 and 9 can be used to supply the adaptor of the RS 232 to RS 485 serial interface that can be purchased from the General Electric Company. They can not be used for any other purpose!

## 4.6 INPUT/OUTPUT EXPANSION CARD TBO

The input/output expansion card TBO can be fitted in a converter of the TPD32 Series. The card provides analog outputs and digital inputs/outputs.

This option card, which is inserted on the XBB connector, is considered by the device as TBO "B".

### 4.6.1 Assignment of the plug-in terminal strip (terminals 1...15) for Option Card TBO

Table 4.6.1.1: Terminal strip connections

| Designation                  | Function  | I/O | Max voltage | Max current                       |
|------------------------------|---|-----|-------------|-----------------------------------|
| 1<br>Analog output 3         | Analog output 3<br>Reference point: Terminal 2<br>Factory set for T current (motor current) | O   | ±10V        | 5mA                               |
| 2<br>COM analog output 3     | Reference point of analog output 3  | —   | —           | —                                 |
| 3<br>Analog output 4         | Analog output 4<br>Reference point: Terminal 4<br>Factory set for motor speed ( Current U)  | O   | ±10V        | 5mA                               |
| 4<br>COM analog output 4     | Reference of analog output 4  | —   | —           | —                                 |
| 5<br>COM digital outputs     | COM digital outputs (Terminals 6...9)   | —   | —           | —                                 |
| 6<br>Digital output 5        | Digital output 5<br>COM: Terminal 5<br>Factory set for Ramp + (Curr limit state)            | O   | +30V        | 50mA                              |
| 7<br>Digital output 6        | Digital output 6<br>COM: Terminal 5<br>Factory set for Ramp - (Overvoltage)                 | O   | +30V        | 50mA                              |
| 8<br>Digital output 7        | Digital output 7<br>COM: Terminal 5<br>Factory set for Spd threshold (Undervoltage)         | O   | +30V        | 50mA                              |
| 9<br>Digital output 8        | Digital output 8<br>COM: Terminal 5<br>Factory set for Overload available (Overcurrent)     | O   | +30V        | 50mA                              |
| 10<br>Supply digital outputs | Supply voltage for digital outputs  | I   | +30V        | depends on the load<br>max 80mA   |
| 11<br>Digital input 5        | Digital input 5<br>COM: Terminal 15<br>Not Factory set                                      | I   | +30V        | 15V/3.2mA<br>24V/5mA<br>30V/6.4mA |
| 12<br>Digital input 6        | Digital input 6<br>COM: Terminal 15<br>Not Factory set                                      | I   | +30V        | 15V/3.2mA<br>24V/5mA<br>30V/6.4mA |
| 13<br>Digital input 7        | Digital input 7<br>COM: Terminal 15<br>Not Factory set                                      | I   | +30V        | 15V/3.2mA<br>24V/5mA<br>30V/6.4mA |
| 14<br>Digital input 8        | Digital input 8<br>COM: Terminal 15<br>Not Factory set                                      | I   | +30V        | 15V/3.2mA<br>24V/5mA<br>30V/6.4mA |
| 15<br>COM digital inputs     | COM of the digital inputs (Terminals 11...14)   | —   | —           |                                   |

Table 4.6.1.2: Cable size for terminals of the option card TBO

| Terminals | Max cable connection section |                 |         | Tightening torque<br>(Nm) |
|-----------|------------------------------|-----------------|---------|---------------------------|
|           | flexible (mm)                | multi-core (mm) | AWG     |                           |
| 1...15    | 0.14...1.5                   | 0.14...1.5      | 28...16 | 0,4                       |

The use of a 3 x 0.1 x 0.02 inches (75 x 2.5 x 0.4 mm) flat screwdriver is recommended. Strip the ends of the cables to a length of 0.26 inch (6.5 mm). Only one unprepared wire (without ferrule) should be connected to each terminal.

#### 4.6.2 Fitting the option card

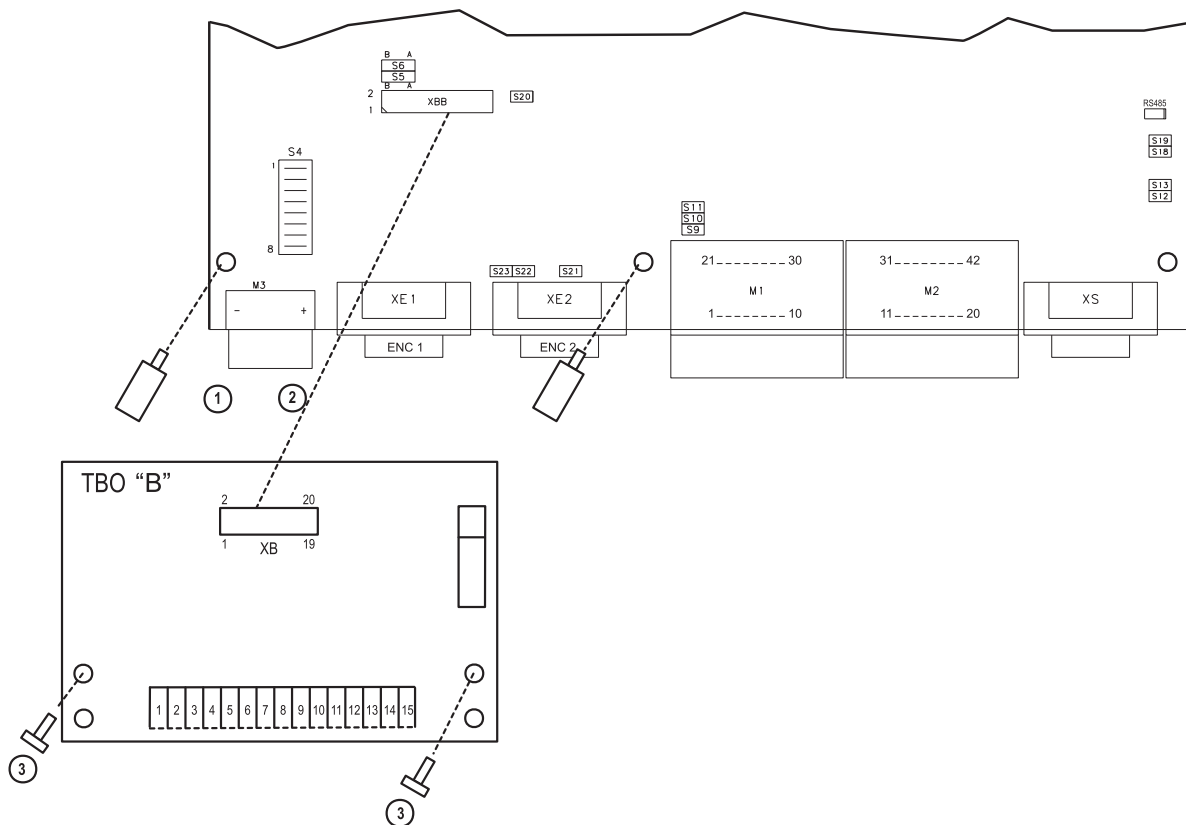

Figure 4.6.2.1: Installing the option card

- 1 Unscrew the existing fixing screws and screw the spacers in the threaded holes
- 2 Fix the option card (connector XB of the option in the connector XBB of the device).
- 3 Fix the option cards on the spacers with the screws.

## 4.7 DIGITAL ENCODER INTERFACE DEII

### 4.7.1 Description

The option card DEII has been projected to adapt, to separate galvanically and to connect a digital encoder to the input XE1 of the converters TPD32 regulations boards. As standard, this input is arranged for the connection of an analog encoder.

The card DEII will be fixed externally to the drive by the mounting rail DIN EN 50 022-35. The input female connector **XS1** must be connected to the digital encoder using a 9-pole male connector, through a shielded cable, Tasker c/186 (6 x 2 x 0.22) with a maximal length of 150 m.

The output male connector **XS2**, provided with shielded cable of 1.5 m, must be connected to the 9-pole connector fitted on the TPD32 regulation card.

Terminals **+Venc** and **0Venc** are needed for the external supply of the digital encoder: the input voltage can be 15V...24V with open Jumpers S1, S2, S3 (standard delivery conditions), or 5V with closed Jumpers S1, S2, S3.

S4 jumper is used to cut out the channel C (no impulse) from the test of encoder loss. S4 closed = canal C included, S4 open = canal C cut out.

The jumper SH is mounted on condition of standard delivery; it must be cut only in case of the shield side encoder is connected to the chassis of the motor, to avoid the forming a ground ring.

For converter operation with the DEII card it is necessary to set the jumper S5, S6 on the regulation board in position A.

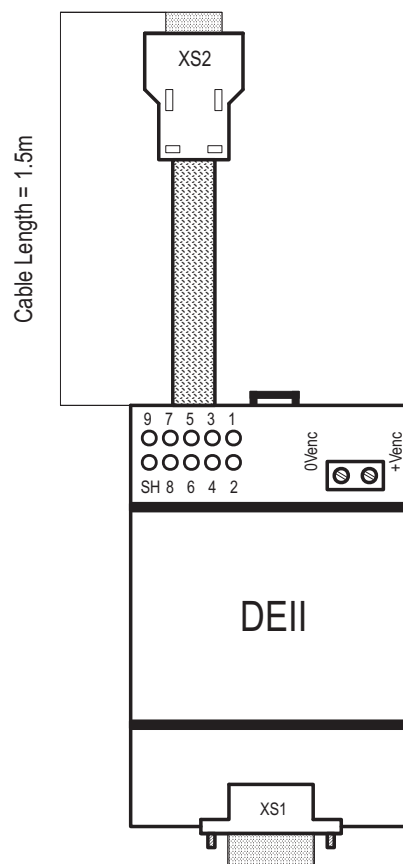

Figure 4.7.1.1: DEII card

## 4.7.2 Terminal Assignment

Table 4.7.2.1: Terminal assignment (Terminals 0Venc and +Venc)

| Designation | Function  | I/O | max volt. | max curr.                 |
|-------------|---|-----|-----------|---------------------------|
| 0Venc       | 0 V supply to the encoder   | I   | -         | -                         |
| +Venc       | +15 ... 24 V supply to the encoder (S1, S2, S3 open)<br>+5V supply to the encoder (S1, S2, S3 closed) | I   | +24V      | depending on encoder data |

I = Input      O = Output

Table 4.7.2.2: Permissible cable cross section on the terminals of option card DEII

| Terminals        | Max cable connection section |              | AWG       | Tightening torque [Nm] |
|------------------|------------------------------|--------------|-----------|------------------------|
|                  | [mm <sup>2</sup> ]           |              |           |                        |
|                  | flexible                     | multi-core   |           |                        |
| 0 Venc and +Venc | 0.14 ... 1.5                 | 0.14 ... 1.5 | 28 ... 14 | 0.5                    |

The use of a 3 x 0.1 x 0.02 inches (75 x 2.5 x 0.4 mm) flat screwdriver is recommended. Strip the ends of the cables to a length of 0.26 inch (6.5 mm). Only one unprepared wire (without ferrite) should be connected to each terminal.

Table 4.7.2.3: XS1 9-pole connector

| Designation | Function   | I/O | max volt. | max curr.                           |
|-------------|--|-----|-----------|-------------------------------------|
| PIN 1       | Channel B-   | I   | +24V      | 10.9mA                              |
| PIN 2       | Supply voltage for the encoder (the allowed level depends on the jumper position, see chapter 4.7.1) |     | +24V      | depending on ext. power supply unit |
| PIN 3       | Channel C+ (zero pulse)  | I/O | +24V      | 10.9mA                              |
| PIN 4       | Channel C- (zero pulse)  |     | +24V      | 10.9mA                              |
| PIN 5       | Channel A+   | I/O | +24V      | 10.9mA                              |
| PIN 6       | Channel A-   |     | +24V      | 10.9mA                              |
| PIN 7       | Reference point for supply voltage   | I/O | -         | -                                   |
| PIN 8       | Channel B+   |     | +24V      | 10.9mA                              |
| PIN 9       | not connected  | I/O | -         | -                                   |

I = Input      O = Output

## 4.8 STANDARD CONNECTION DIAGRAMS

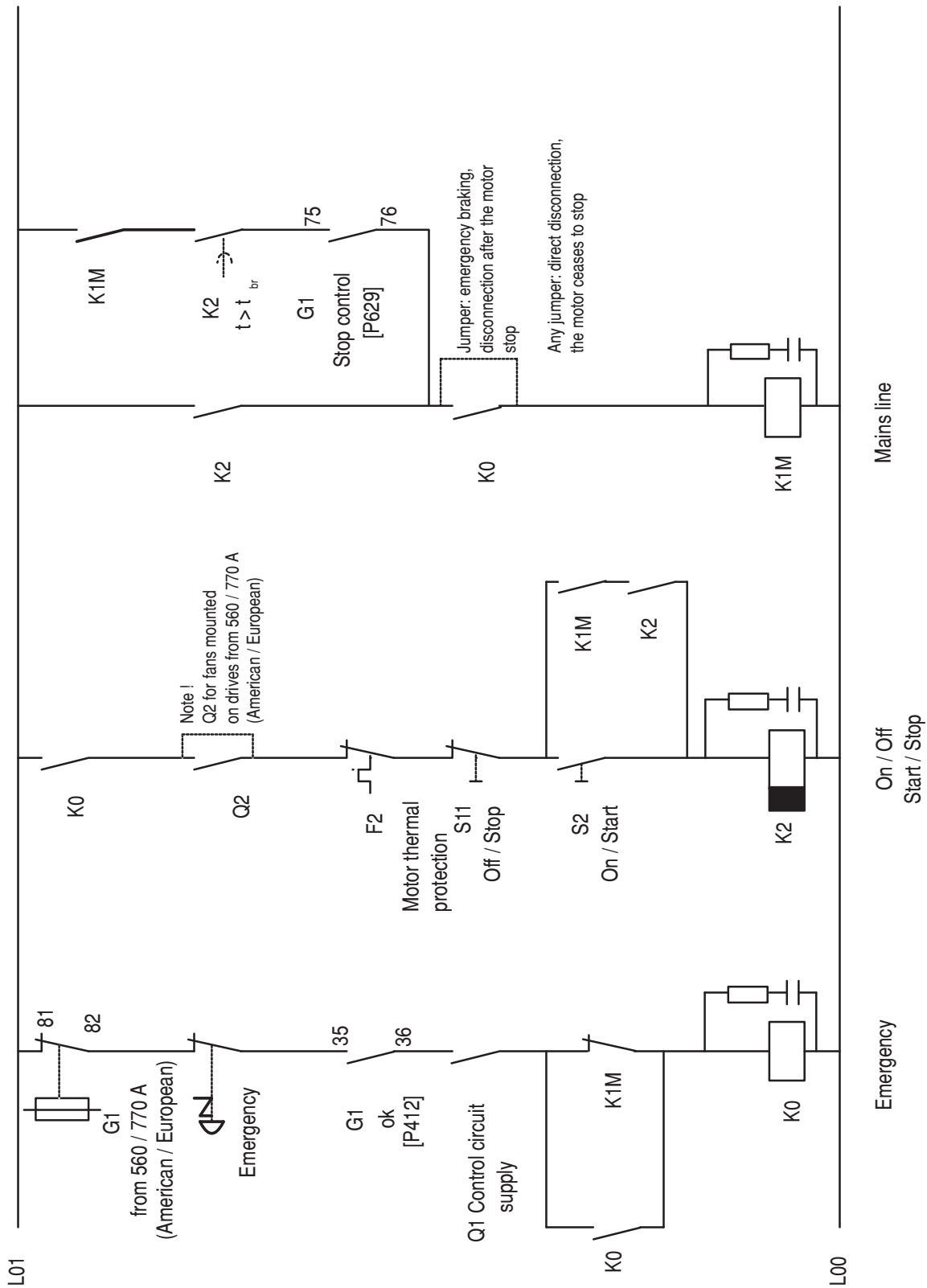

Figure 4.8.1: Control sequencing



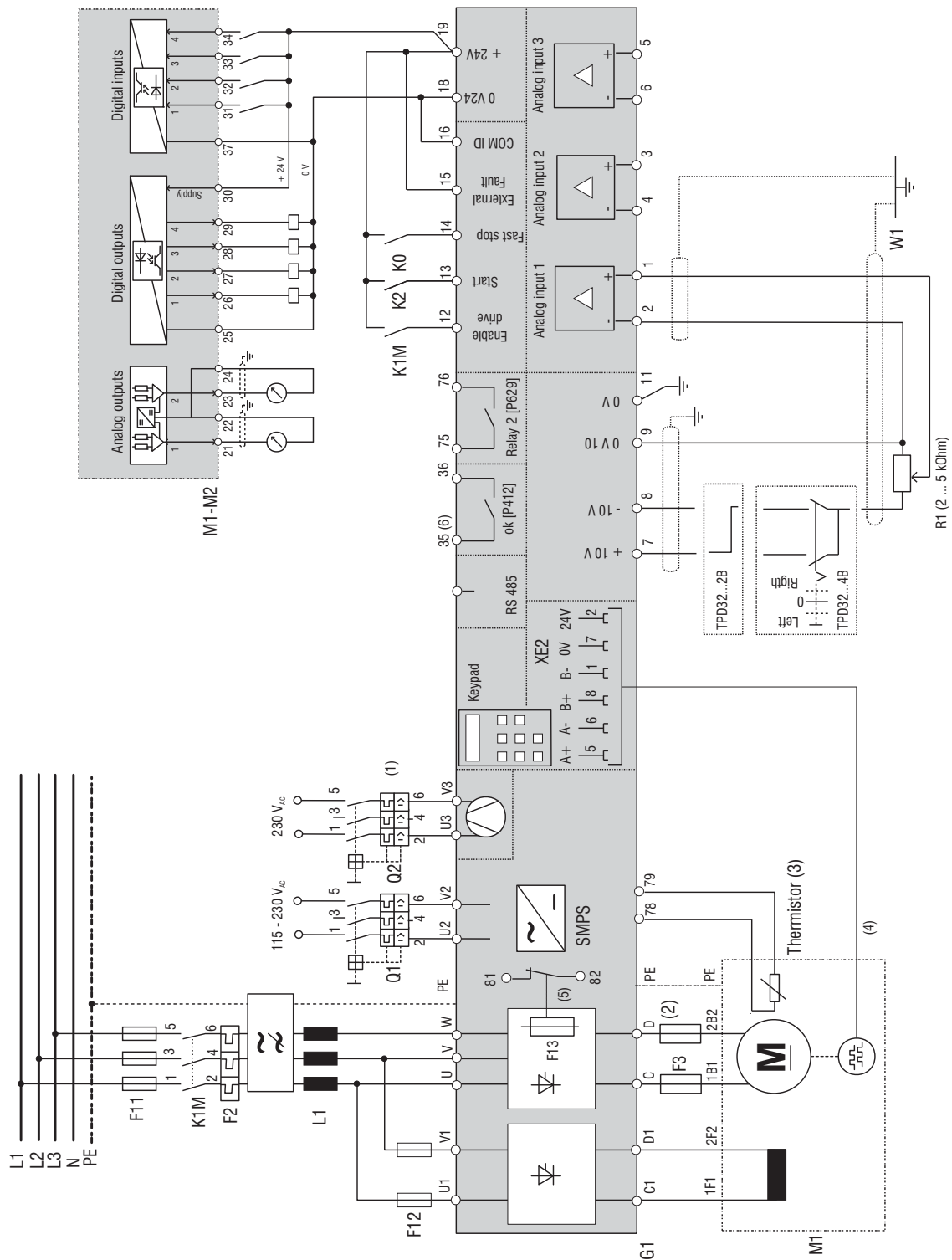

Figure 4.8.3: Typical connections

Typical wiring diagram for the standard configuration of the converter.

It is necessary to follow the instructions for mounting and wiring given in the chapters concerning engineering notes and EMC measures.

Option cards connection is not indicated here.

It is not considered the autorestart of the drive after an alarm condition.

(1) Fan with external supply only above 560/770 A included (American/European).

(2) Fuses only for TPD32...4B up to 450/650 A (American/European).

(3) 1Kohm resistor connected when the thermistor is not present.

(4) The indicated connections are relative for a digital Encoder.

(5) From 770 A (European) and 560 A (American) sizes.

(6) On the Power/Control card "FIR ...".

Connections for sinusoidal encoder and tachogenerator are serately indicated.

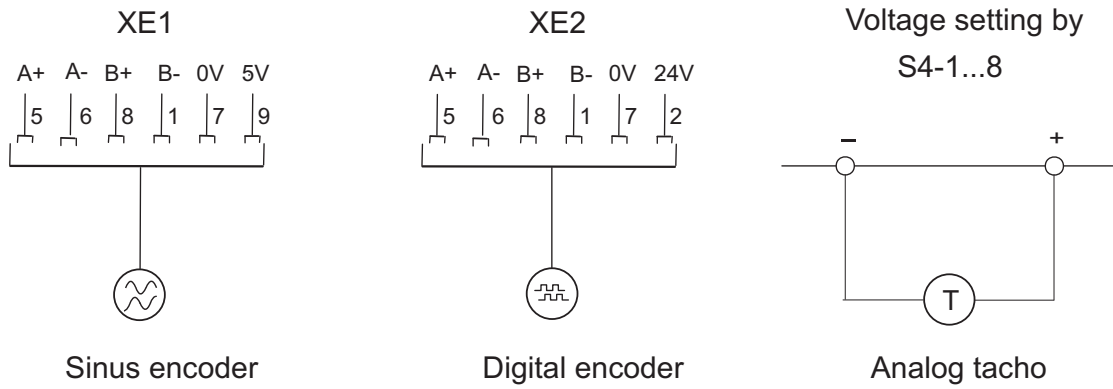

Figure 4.8.4: Encoder and Tachometer Connections

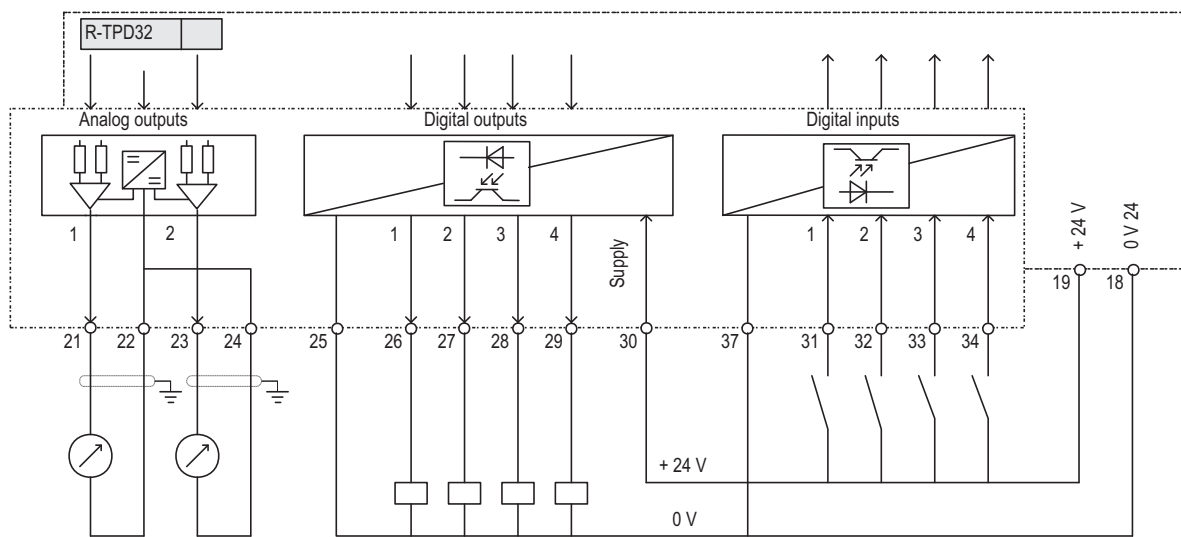

Figure 4.8.5: Programmable Inputs/outputs with relay and contacts

**Note!**

To improve the noise immunity it is advisable to connect the common of the outputs (terminals 22/24, 25/37) with the ground (terminals 10 or 20 of the regulation board). It is not possible, the above mentioned common have to be grounded by means of a 0,1  $\mu\text{F}/250\text{V}$  capacitor.

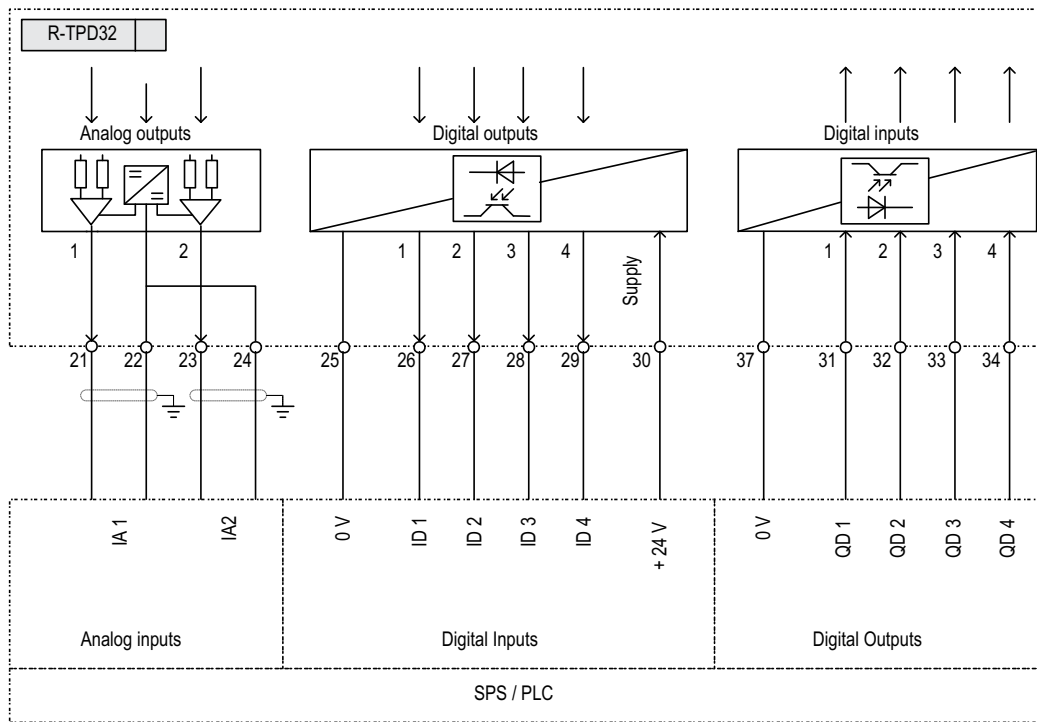

Figure 4.8.6: Programmable Inputs/outputs with PLC

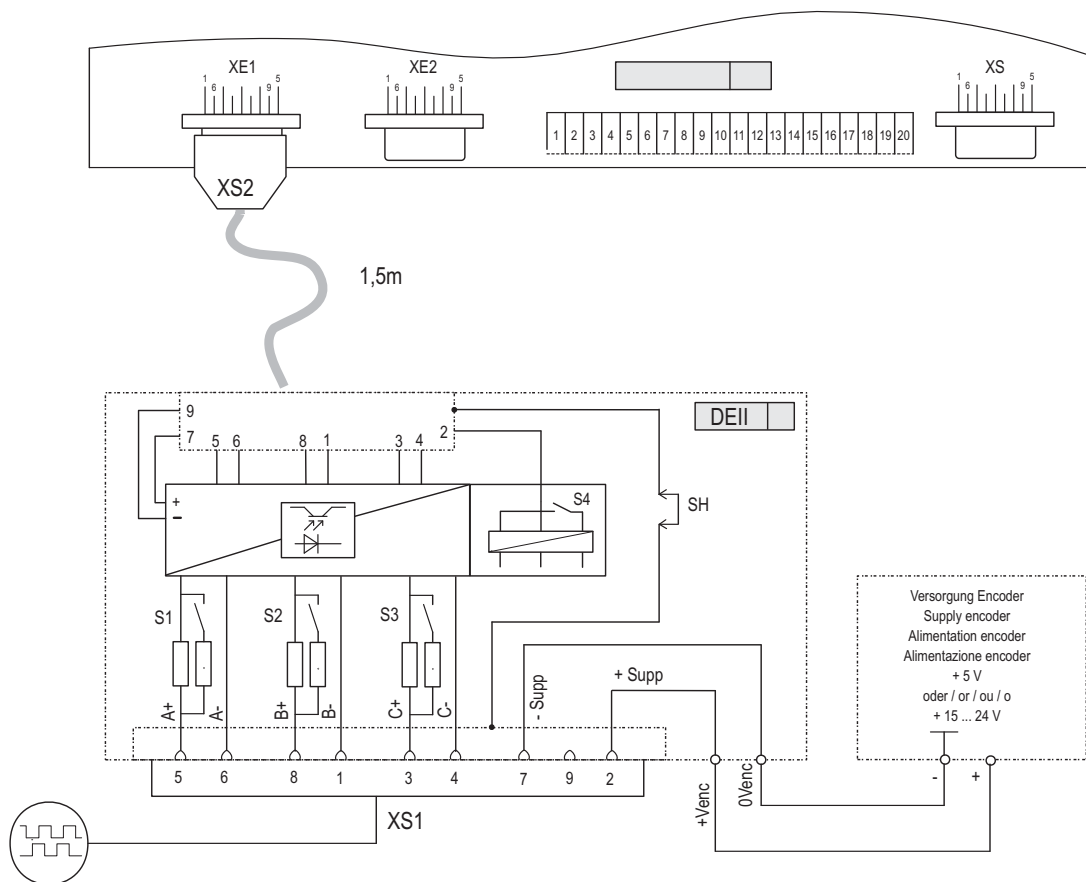

Figure 4.8.7: DEII connection

## 4.9 CIRCUIT PROTECTION

### 4.9.1 Fuses

#### Fuses of the power section

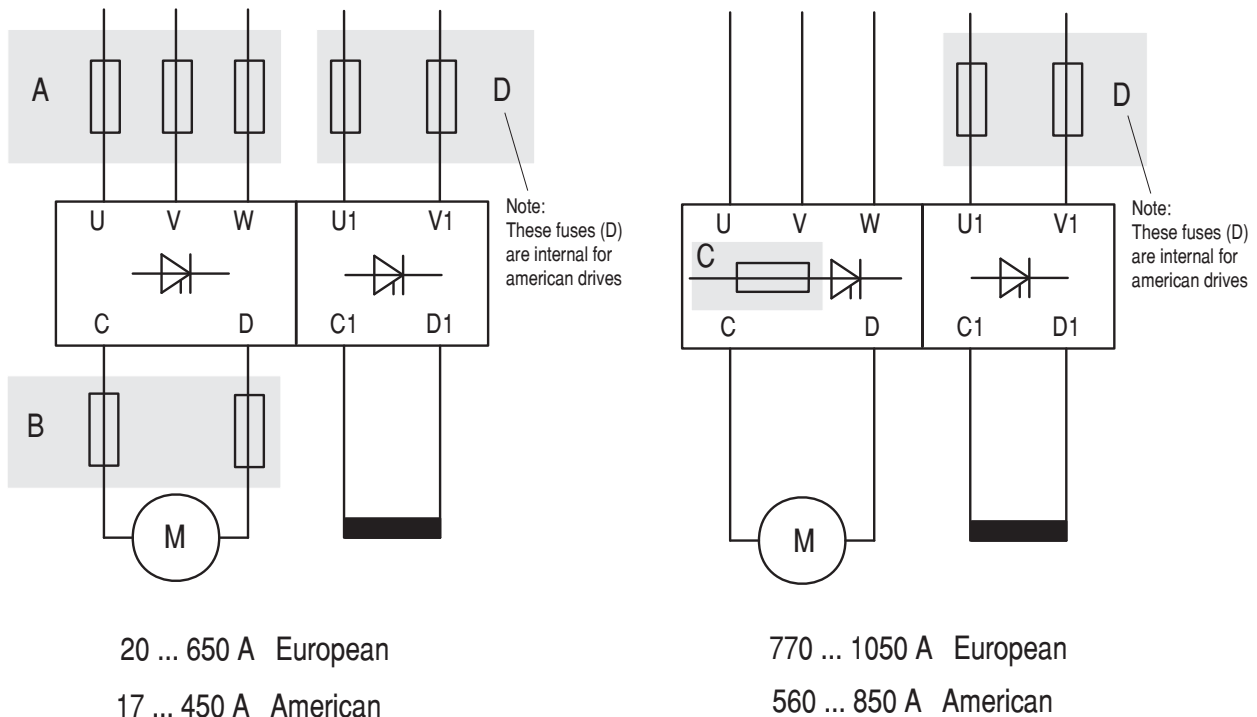

Figure 4.9.1.1: Position of the super fast fuses

For protection of the bridge thyristors use fast acting fuses. The following recommended fuses are externally mounted. Models TPD32-.../...-560..., TPD32-.../...-770... and higher, HAVE internally mounted fuses provided (Code C on table 4.9.1.1).

#### **Note!**

The TPD32...2B... and TPD32...4B... Drives (500V AC input supply) have the field converter fuses internally mounted. The fuses type for the different sizes of converter are the following:

|  |               |            |
|--|---------------|------------|
| TPD32 size up to 56 / 70 A *           | Bussman       | FWH-015A6F |
| TPD32 size 88 / 110 ... 850 / 1050 A * | Bussman       | FWC 25A10F |
|  | Gould Shawmut | A60Q25-2   |

\* American / European

Table 4.9.1.1: Recommended fuses (externally mounted)

| Code | Pieces | European             | European             | American             | American |
|------|--------|----------------------|----------------------|----------------------|----------|
| A    | 3      | TPD32-.../...-20-..  | Z14gR20 (GRD2/20)    | TPD32-.../...-17-..  | A70P25   |
|      | 3      |                      | Nr. 10 005 07.25     |                      | FWP25    |
| B*   | 2      |                      | Z14gR20 (GRD2/20)    |                      | A70P25   |
|      | 2      |                      | Nr. 10 005 07.30     |                      | FWP25    |
| D    | 2      |                      | Z14gR20 (GRD2/20)    |                      | A70P20   |
|      | 2      |                      | Nr. 10 005 07.20     |                      | FWP20    |
| A    | 3      | TPD32-.../...-40-..  | Z22gR50 (GRD3/50)    | TPD32-.../...-35-..  | A70P40   |
|      | 3      |                      | Nr. 10 005 07.50     |                      | FWP40    |
| B*   | 2      |                      | Z22gR63 (GRD3/63)    |                      | A70P50   |
|      | 2      |                      | Nr. 10 005 07.63     |                      | FWP50    |
| D    | 2      |                      | Z14gR20 (GRD2/20)    |                      | A70P20   |
|      | 2      |                      | Nr. 10 005 07.20     |                      | FWP20    |
| A    | 3      | TPD32-.../...-70-..  | Z22gR63 (GRD3/63)    | TPD32-.../...-56-..  | A70P80   |
|      | 3      |                      | Nr. 10 007 07.63     |                      | FWP80    |
| B*   | 2      |                      | S00UF01/80/100A/660V |                      | A70P80   |
|      | 2      |                      | Nr. 20 189 20, 80 A  |                      | FWP80    |
| D    | 2      |                      | Z14gR20 (GRD2/20)    |                      | A70P20   |
|      | 2      |                      | Nr. 10 005 07.20     |                      | FWP20    |
| A    | 3      | TPD32-.../...-110-.. | S00UF1/80/100A/660V  | TPD32-.../...-88-..  | A70P100  |
|      | 3      |                      | Nr. 20 189 20.100    |                      | FWP100   |
| B*   | 2      |                      | S00UF1/80/125A/660V  |                      | A70P150  |
|      | 2      |                      | Nr. 20 189 20.125    |                      | FWP150   |
| D    | 2      |                      | Z14gR20 (GRD2/20)    |                      | A70P20   |
|      | 2      |                      | Nr. 10 005 07.20     |                      | FWP20    |
| A    | 3      | TPD32-.../...-140-.. | S00UF1/80/125A/660V  | TPD32-.../...-112-.. | A70P150  |
|      | 3      |                      | Nr. 20 189 20.125    |                      | FWP150   |
| B*   | 2      |                      | S00UF1/80/160A/660V  |                      | A70P175  |
|      | 2      |                      | Nr. 20 189 20.160    |                      | FWP175   |
| D    | 2      |                      | Z14gR20 (GRD2/20)    |                      | A70P20   |
|      | 2      |                      | Nr. 10 005 07.20     |                      | FWP20    |
| A    | 3      | TPD32-.../...-185-.. | S00UF1/80/200A/660V  | TPD32-.../...-148-.. | A70P175  |
|      | 3      |                      | Nr. 20 189 20.200    |                      | FWP175   |
| B*   | 2      |                      | S00UF1/80/200A/660V  |                      | A70P200  |
|      | 2      |                      | Nr. 20 189 20.200    |                      | FWP200   |
| D    | 2      |                      | Z14gR20 (GRD2/20)    |                      | A70P20   |
|      | 2      |                      | Nr. 10 005 07.20     |                      | FWP20    |
| A    | 3      | TPD32-.../...-280-.. | S1UF1/110/250A/660V  | TPD32-.../...-224-.. | A70P300  |
|      | 3      |                      | Nr. 20 458 20.250    |                      | FWP300   |
| B*   | 2      |                      | S1UF1/110/315A/660V  |                      | A70P350  |
|      | 2      |                      | Nr. 20 458 20.315    |                      | FWP350   |
| D    | 2      |                      | Z14gR32 (GRD2/30)    |                      | A70P30   |
|      | 2      |                      | Nr. 10 005 07.30     |                      | FWP30    |
| A    | 3      | TPD32-.../...-350-.. | S1UF1/110/315A/660V  | TPD32-.../...-280-.. | A70P350  |
|      | 3      |                      | Nr. 20 458 20.315    |                      | FWP350   |
| B*   | 2      |                      | S2UF1/110/400A/660V  |                      | A70P400  |
|      | 2      |                      | Nr. 20 459 20.400    |                      | FWP400   |
| D    | 2      |                      | Z14gR32 (GRD2/30)    |                      | A70P30   |
|      | 2      |                      | Nr. 10 005 07.30     |                      | FWP30    |

| Code | Pieces | European              | Europe              | American             | American           |
|------|--------|-----------------------|---------------------|----------------------|--------------------|
| A    | 3      | TPD32-.../...-420-..  | S2UF1/110/400A/660V | TPD32-.../...-336-.. | A70P400            |
|      | 3      |                       | Nr. 20 459 20.400   |                      | FWP400             |
| B*   | 2      |                       | S2UF1/110/500A/660V |                      | A70P500            |
|      | 2      |                       | Nr. 20 459 20.500   |                      | FWP500             |
| D    | 2      |                       | Z14gR32 (GRD2/30)   |                      | A70P30             |
|      | 2      |                       | Nr. 10 005 07.30    |                      | FWP30              |
| A    | 3      | TPD32-.../...-500-..  | S2UF1/110/500A/660V | TPD32-.../...-400-.. | A70P500            |
|      | 3      |                       | Nr. 20 459 20.500   |                      | FWP500             |
| B*   | 2      |                       | S2UF1/110/630A/660V |                      | A70P600            |
|      | 2      |                       | Nr. 20 459 20.630   |                      | FWP600             |
| D    | 2      |                       | Z14gR32 (GRD2/30)   |                      | A70P30             |
|      | 2      |                       | Nr. 10 005 07.30    |                      | FWP30              |
| A    | 3      | TPD32-.../...-650-..  | S2UF1/110/630A/660V | TPD32-.../...-450-.. | A70P600            |
|      | 3      |                       | Nr. 20 4595 20.630  |                      | FWP600             |
| B*   | 2      |                       | S3UF1/110/710A/660V |                      | A70P700            |
|      | 2      |                       | Nr. 20 460 20.710   |                      | FWP700             |
| D    | 2      |                       | Z14gR32 (GRD2/30)   |                      | A70P30             |
|      | 2      |                       | Nr. 10 005 07.30    |                      | FWP30              |
| C**  | 3      | TPD32-.../...-770-2B  | 170M5464/800A/660V  | TPD32-.../...-560-2B | 170M5464/800A/660V |
|      |        |                       | A2-66C800TS         |                      | A2-66C800TS        |
| D    | 2      |                       | Z14gR32 (GRD2/30)   |                      | A70P30             |
|      | 2      |                       | Nr. 10 005 07.30    |                      | FWP30              |
| C**  | 6      | TPD32-.../...-770-4B  | 170M5462/630A/660V  | TPD32-.../...-560-4B | 170M5462/630A/660V |
|      |        |                       | A2-66C630TS         |                      | A2-66C630TS        |
| D    | 2      |                       | Z14gR32 (GRD2/30)   |                      | A70P30             |
|      | 2      |                       | Nr. 10 005 07.30    |                      | FWP30              |
| C**  | 3      | TPD32-.../...-1000-2B | 170M5464/1000A/660V | TPD32-.../...-800-2B | 70M5464/1000A/660V |
|      |        |                       | A2-66C1000TS        |                      | A2-66C1000TS       |
| D    | 2      |                       | Z14gR32 (GRD2/30)   |                      | A70P30             |
|      | 2      |                       | Nr. 10 005 07.30    |                      | FWP30              |
| C**  | 6      | TPD32-.../...-1050-4B | 170M5464/800A/660V  | TPD32-.../...-850-4B | 170M5464/800A/660V |
|      |        |                       | A2-66C800TS         |                      | A2-66C800TS        |
| D    | 2      |                       | Z14gR32 (GRD2/30)   |                      | A70P30             |
|      | 2      |                       | Nr. 10 005 07.30    |                      | FWP30              |

\* Necessary only for the four quadrant functioning

\*\* These fuses are internally mounted and are provided on the delivery

A External fuses for the armature converter on the AC input side

B External fuses for the armature circuit on the direct current side

C Internal armature fuses for the device starting from type 560A / 770A (American/European)

D External fuses for the field circuit on the AC input side.

**Note: These fuses are necessary only for TPD32-400... Internal fuses are provided for TPD32-500... .**

**Note!**

When with the same letter different fuses are stated, it means that they can be used alternatively. The different types differ for the building forms and for the production house. See the following indications.

Fuses producer: Type Z14gR..., GRD2... (E27), Z22gR..., GRD3... (E33)

S... (screw fuses with a distance 80 or 110 mm) Jean Müller, Eltville

A70P, A2-66C Gould Shawmut

FWP..., 170 M Bussmann

**Note!**

The fuse technical data (dimensions, weights, dissipated powers, fuses carrier etc.), can be derived from the relative data sheets.

## 4.9.2 Fuses selection when the Overload function is activated

> 100% for 60 seconds - European

> 150% for 60 seconds - American

Different fuses must be used when the current is higher than the rated one (overload current). Maximum values allowed for each type are listed on the next table. Be careful to coordinate the right dimension. Example: the 1st fuse type on power section A (see figure 4.9.1.1) have to be coordinated with the 1st fuse type on section B and so on.

Table 4.9.2.1: Overload fuses

| Converter            | Code | Pieces              | 400 VAC Input supply | 500 VAC Input Supply |
|----------------------|------|---------------------|----------------------|----------------------|
| TPD32-.../...-17-..  | A    | 3                   | Z14gR25 (GRD2/25)    | Z14gR25 (GRD2/25)    |
|                      |      | 3                   | Nr. 10 005 07.25     | Nr. 10 005 07.25     |
| TPD32-.../...-20-..  | B*   | 2                   | Z14gR32 (GRD2/30)    | Z14gR32 (GRD2/30)    |
|                      |      | 2                   | Nr. 10 005 07.30     | Nr. 10 005 07.30     |
| TPD32-.../...-35-..  | A    | 3                   | Z22gR50 (GRD3/50)    | Z14gR40 (GRD3/35)    |
|                      |      | 3                   | Nr. 10 005 07.50     | Nr. 10 005 07.35     |
| TPD32-.../...-40-..  | B*   | 2                   | Z22gR63 (GRD3/63)    | Z22gR50 (GRD3/50)    |
|                      |      | 2                   | Nr. 10 005 07.63     | Nr. 10 005 07.50     |
| TPD32-.../...-56-..  | A    | 3                   | Z22gR80 (GRD4/80)    | S00UF01/80/100A/660V |
|                      |      | 3                   | S00UF1/80/80A/660V   | S00UF01/80/100A/660V |
|                      |      | 3                   | S00UF01/80/100A/660V |                      |
|                      |      | 3                   | Nr. 20 189 20, 80 A  | Nr. 20 189 20, 80 A  |
| TPD32-.../...-70-..  | B*   | 2                   | Z22gR100 (GRD4/100)  | Z22gR100 (GRD4/100)  |
|                      |      | 2                   | S00UF1/80/100A/660V  | S00UF1/80/100A/660V  |
|                      | 2    | S00UF1/80/125A/660V |                      |                      |
|                      | 2    | Nr. 20 189 20,100 A | Nr. 20 189 20,100 A  |                      |
| TPD32-.../...-88-..  | A    | 3                   | S00UF1/80/100A/660V  | S00UF1/80/100A/660V  |
|                      |      | 3                   | Nr. 20 189 20.100    | Nr. 20 189 20.100    |
| TPD32-.../...-110-.. | B*   | 2                   | S00UF1/80/125A/660V  | S00UF1/80/125A/660V  |
|                      |      | 2                   | Nr. 20 189 20.125    | Nr. 20 189 20.125    |
| TPD32-.../...-112-.. | A    | 3                   | S00UF1/80/160A/660V  | S00UF1/80/160A/660V  |
|                      |      | 3                   | Nr. 20 189 20.160    | Nr. 20 189 20.160    |
| TPD32-.../...-140-.. | B*   | 2                   | S00UF1/80/200A/660V  | S00UF1/80/200A/660V  |
|                      |      | 2                   | Nr. 20 189 20.200    | Nr. 20 189 20.200    |
| TPD32-.../...-148-.. | A    | 3                   | S00UF1/80/200A/660V  | S00UF1/80/200A/660V  |
|                      |      | 3                   | Nr. 20 189 20.200    | Nr. 20 189 20.200    |
| TPD32-.../...-185-.. | B*   | 2                   | S00UF1/80/200A/660V  | S00UF1/80/200A/660V  |
|                      |      | 2                   | Nr. 20 189 20.200    | Nr. 20 189 20.200    |
| TPD32-.../...-224-.. | A    | 3                   | S1UF1/110/315A/660V  | S1UF1/110/315A/660V  |
|                      |      | 3                   | S1UF1/110/350A/660V  | S1UF1/110/350A/660V  |
|                      |      | 3                   | Nr. 20 458 20.315    | Nr. 20 458 20.315    |
|                      | B*   | 2                   | S2UF1/110/400A/660V  | S2UF1/110/400A/660V  |
| 2                    |      | S2UF1/110/400A/660V | S2UF1/110/400A/660V  |                      |
| TPD32-.../...-280-.. | A    | 3                   | S1UF1/110/400A/660V  | S1UF1/110/400A/660V  |
|                      |      | 3                   | S1UF1/110/450A/660V  | S1UF1/110/450A/660V  |
|                      |      | 3                   | Nr. 20 459 20.400    | Nr. 20 459 20.400    |
|                      | B*   | 2                   | S2UF1/110/500A/660V  | S2UF1/110/500A/660V  |
| 2                    |      | S2UF1/110/500A/660V | S2UF1/110/500A/660V  |                      |
| TPD32-.../...-336-.. | A    | 3                   | S2UF1/110/500A/660V  | S2UF1/110/500A/660V  |
|                      |      | 3                   | Nr. 20 459 20.500    | Nr. 20 459 20.500    |
|                      |      | 3                   | S2UF1/110/630A/660V  | S2UF1/110/630A/660V  |
|                      | B*   | 2                   | S2UF1/110/630A/660V  | S2UF1/110/630A/660V  |
| 2                    |      | Nr. 20 459 20.630   | Nr. 20 459 20.630    |                      |
| TPD32-.../...-400-.. | A    | 3                   | S2UF1/110/630A/660V  | S2UF1/110/630A/660V  |
|                      |      | 3                   | S2UF01/110/710A/660V |                      |
|                      |      | 3                   | Nr. 20 459 20.630    | Nr. 20 459 20.630    |
|                      | B*   | 2                   | S3UF1/110/710A/660V  | S3UF1/110/710A/660V  |
| 2                    |      | S3UF1/110/710A/660V | S3UF1/110/710A/660V  |                      |
| TPD32-.../...-450-.. |      | 2                   | Nr. 20 460 20.710    | Nr. 20 460 20.710    |

| Converter            | Code | Pieces | 400 VAC Input supply | 500 VAC Input Supply |
|----------------------|------|--------|----------------------|----------------------|
| TPD32-.../...-450-.. | A    | 3      | S2UF1/110/630A/660V  | S2UF1/110/630A/660V  |
|                      |      | 3      | S2UF01/110/710A/660V |                      |
|                      |      | 3      | Nr. 20 459 20.630    | Nr. 20 459 20.630    |
| TPD32-.../...-650-.. | B*   | 2      | S3UF1/110/710A/660V  | S3UF1/110/710A/660V  |
|                      |      | 2      | S3UF1/110/710A/660V  |                      |
|                      |      | 2      | Nr. 20 460 20.710    | Nr. 20 460 20.710    |

A External fuses for the armature circuit on the DC side

B External fuses for the armature converter on the AC input side

\* Necessary only for the four quadrant functioning

**Note for sizes 770 ... 1050 A: the armature fuses are internally mounted (see table 4.9.1.1)**

## 4.9.3 Internal Fuses

Table 4.9.3.1: Internal fuses

| Converter   | Designation | Fuses for                          | Fuse   | Mounted on              |
|---|-------------|------------------------------------|--|-------------------------|
| TPD32-.../...-17-.. - 148-..<br>TPD32-.../...-20-.. - 185-..    | F1          | + 24V<br>power supply out          | IEC 250 V 2.50 A slo-blo<br>0.2" x 0.8" (5 x 20 mm)  | SW1-31<br>≥ rev. K (*)  |
| TPD32-.../...-224-.. - 850-..<br>TPD32-.../...-280-.. - 1050-.. | F1          | + 24V<br>power supply out          | IEC 250 V 2.50 A slo-blo<br>0.2" x 0.8" (5 x 20 mm)  | SW2-32<br>≥ rev. J (**) |
|   | F2          | + 24V<br>power supply in           | IEC 250 V 2.50 A slo-blo<br>0.2" x 0.8" (5 x 20 mm)  | SW3-32                  |
|   | F1/F2/F3    | Varistor fuse<br><br>Varistor fuse | IEC 500 V 16 A fast acting<br>0.24" x 1.26" (6 x 32 mm)<br>IEC 500 V 25 A fast acting<br>0.24" x 1.26" (6 x 32 mm) | SW2-31<br><br>FL-31     |

Producer : F1 Omega (Europe) ST520225, Bussman S506-2.5-R, SIBA 179120-2,5

(\*) F1 (SW1-31 < rev. K) = IEC 250 V 1 A slo-blo, 0.2" x 0.8" (5 x 20 mm)

(\*\*) F1 (SW2-32 < rev. J) = IEC 250 V 3.15 A fast acting, 0.2" x 0.8" (5 x 20 mm)

**Internal field exciter fuse** (American version only; for "standard" version the fuses are externally mounted).

| Device                        | Internal field exciter fuse |                 |            |                    |
|-------------------------------|-----------------------------|-----------------|------------|--------------------|
|                               | Quantity                    | Fuse            | Type       | Producer           |
| TPD32-.../...-17-.. - 148-..  | 2 pieces                    | 500 V 15 A fast | FWH-015a6F | Cooper/Bussman P/N |
| TPD32-.../...-224-.. - 850-.. | 2 pieces                    | 500 V 25 A fast | FWH-025a6F | Cooper/Bussman P/N |



#### 4.9.4 AC input contactors

**Note!** The contactor sizes must be selected based on the converter rated current. The sizing basis is the thermo current AC1, which is absorbed by the input during the rated functioning.

**Note!** The technical data of the contactors, as for example weights, dissipated powers, auxiliary contacts etc. can be found in the appropriate data sheets.

#### 4.9.5 Control power protection

The 115 VAC/230 VAC control power input, U2 & V2, for the TPD32 are required to be short circuit protected. This protection can be provided by using standard time delay fuses, or circuit breaker.

The circuit breaker and/or time delay fuses must be selected to survive the short circuit available current of the feeder source for this circuit, and the inrush current of the drive power supply.

The rating of the fuses or circuit breaker should be sized mainly to protect the wiring from the fuses/circuit breaker connections to U2 & V2, and not nuisance trip or blow from the inrush current.

The table below, Table 4.9.5, lists the input current characteristics of the control power.

Table 4.9.5: Control power protection

| Device                         |                                 | Regulation Power Supply |       |                     |       |                      |       |
|--------------------------------|---------------------------------|-------------------------|-------|---------------------|-------|----------------------|-------|
| American                       | European                        | Card                    | Power | Rated input current |       | Inrush input current |       |
|                                |                                 |                         |       | 115 V               | 230 V | 115 V                | 230 V |
| TPD32-.../...-17-..<br>to ...  | TPD32-.../...-20-..<br>to ...   | SW1-31                  | 60 W  | 1 A                 | 0.5 A | 20 A                 | 10 A  |
| TPD32-.../...-148-..<br>to ... | TPD32-.../...-185-..<br>to ...  |                         |       |                     |       |                      |       |
| TPD32-.../...-224-..<br>to ... | TPD32-.../...-280-..<br>to ...  | SW2-32                  | 110 W | 1.2 A               | 0.7 A | 15 A                 | 7.5 A |
| TPD32-.../...-850-..<br>to ... | TPD32-.../...-1050-..<br>to ... |                         |       |                     |       |                      |       |

GD0315g

The control power input is best served by a power source that is stabilized and buffered from the power system transients.

The control power of many drives can be fed from a single source, as long as proper distribution protection is provided.

## 4.10 REACTORS / FILTERS

In order to provide AC line protection from transients and high frequencies, it is necessary to insert a three-phase reactor on the AC input of the TPD32. The values here stated take into consideration the recommendation per EN 60146-1-1, IEC 146-1-2, EN 61136-1.

The reactors can be provided by means of line reactors or an isolation transformer.

### 4.10.1 AC input choke

The type of the required AC input choke depends on

- the current absorbed by the AC input
- the AC input voltage
- the relative short circuit voltage
- the AC input frequency

The values stated in the following tables refer to a functioning with the connected converter rated current and with a relative short circuit voltage of  $u_k = 4\%$ . The saturation current of the reactors is 200% of the full load current rating of the reactor.

In case of functioning with a motor having a rated current lower than the converter one it is possible to choose the main reactor on the basis of the motor current stated on the AC input side (armature current  $\times 0.82 \times 1.05$ ). The reactor saturation current can also be calculated according the required motor overload.

#### Example: calculating the AC input choke

Motor:  $V_a = 400V$      $I_a = 80 A$      $P = 29.4 kW$  Overload 150%  $I_a$

Converter                      TPD32-400/420-110-4B

Mains voltage:                 $V_{mains} = 400 V$      $f_{mains} = 50 Hz$

AC input current:               $I_{mains} = I_a \cdot 0.82 \cdot 1.05 = 80 \cdot 0.82 \cdot 1.05 = 68.9 A$

AC input inductance:          $L = \frac{0.04 \cdot V_{mains}}{\sqrt{3} \cdot 2\pi \cdot f_{mains} \cdot I_{mains}} = \frac{0.04 \cdot 400}{\sqrt{3} \cdot 2\pi \cdot 50 \cdot 68.9} = 0.427 mH$

Choke saturation current:      $I_{sat} = 1.5 I_{mains} = 103.3 A$

Table 4.10.1.1: AC input choke

| Converter                                     | Main three-phase inductance |                      |                        |            |
|---|-----------------------------|----------------------|------------------------|------------|
|   | Rated choke [mH]            | Rated ac current [A] | Saturation current [A] | Freq. [Hz] |
| <b>Main 400 V, 3Ph, 50 Hz</b>                 |                             |                      |                        |            |
| TPD32-.../...-20-..<br>TPD32-.../...-17-..    | 1.71                        | 17.2                 | 34.4                   | 50         |
| TPD32-.../...-40-..<br>TPD32-.../...-35-..    | 0.855                       | 34.4                 | 68.8                   | 50         |
| TPD32-.../...-70-..<br>TPD32-.../...-56-..    | 0.488                       | 60.2                 | 120.4                  | 50         |
| TPD32-.../...-110-..<br>TPD32-.../...-88-..   | 0.311                       | 94.6                 | 189.2                  | 50         |
| TPD32-.../...-140-..<br>TPD32-.../...-112-..  | 0.244                       | 120.4                | 240.8                  | 50         |
| TPD32-.../...-185-..<br>TPD32-.../...-148-..  | 0.185                       | 159                  | 318                    | 50         |
| TPD32-.../...-280-..<br>TPD32-.../...-224-..  | 0.122                       | 241                  | 482                    | 50         |
| TPD32-.../...-350-..<br>TPD32-.../...-280-..  | 0.098                       | 301                  | 602                    | 50         |
| TPD32-.../...-420-..<br>TPD32-.../...-336-..  | 0.081                       | 361                  | 722                    | 50         |
| TPD32-.../...-500-..<br>TPD32-.../...-400-..  | 0.068                       | 430                  | 860                    | 50         |
| TPD32-.../...-650-..<br>TPD32-.../...-450-..  | 0.053                       | 559                  | 1118                   | 50         |
| TPD32-.../...-770-..<br>TPD32-.../...-560-..  | 0.044                       | 662                  | 1324                   | 50         |
| TPD32-.../...-1000-..<br>TPD32-.../...-800-.. | 0.034                       | 860                  | 1720                   | 50         |
| TPD32-.../...-1050-..<br>TPD32-.../...-850-.. | 0.033                       | 903                  | 1806                   | 50         |
| <b>Main 460 V, 3Ph, 60 Hz</b>                 |                             |                      |                        |            |
| TPD32-.../...-20-..<br>TPD32-.../...-17-..    | 1.638                       | 17.2                 | 34.4                   | 60         |
| TPD32-.../...-40-..<br>TPD32-.../...-35-..    | 0.819                       | 34.4                 | 68.8                   | 60         |
| TPD32-.../...-70-..<br>TPD32-.../...-56-..    | 0.468                       | 60.2                 | 120.4                  | 60         |
| TPD32-.../...-110-..<br>TPD32-.../...-88-..   | 0.298                       | 94.6                 | 189.2                  | 60         |
| TPD32-.../...-140-..<br>TPD32-.../...-112-..  | 0.234                       | 120.4                | 240.8                  | 60         |
| TPD32-.../...-185-..<br>TPD32-.../...-148-..  | 0.177                       | 159                  | 318                    | 60         |
| TPD32-.../...-280-..<br>TPD32-.../...-224-..  | 0.117                       | 241                  | 482                    | 60         |
| TPD32-.../...-350-..<br>TPD32-.../...-280-..  | 0.094                       | 301                  | 602                    | 60         |
| TPD32-.../...-420-..<br>TPD32-.../...-336-..  | 0.078                       | 361                  | 722                    | 60         |
| TPD32-.../...-500-..<br>TPD32-.../...-400-..  | 0.066                       | 430                  | 860                    | 60         |
| TPD32-.../...-650-..<br>TPD32-.../...-450-..  | 0.050                       | 559                  | 1118                   | 60         |
| TPD32-.../...-770-..<br>TPD32-.../...-560-..  | 0.043                       | 662                  | 1324                   | 60         |
| TPD32-.../...-1000-..<br>TPD32-.../...-800-.. | 0.033                       | 860                  | 1720                   | 60         |
| TPD32-.../...-1050-..<br>TPD32-.../...-850-.. | 0.031                       | 903                  | 1806                   | 60         |

| Converter                                     | Main three-phase inductance |                      |                        |            |
|---|-----------------------------|----------------------|------------------------|------------|
|   | Rated choke [mH]            | Rated ac current [A] | Saturation current [A] | Freq. [Hz] |
| <b>Main 500 V, 3Ph, 50 Hz</b>                 |                             |                      |                        |            |
| TPD32-.../...-20-..<br>TPD32-.../...-17-..    | 2.137                       | 17.2                 | 34.4                   | 50         |
| TPD32-.../...-40-..<br>TPD32-.../...-35-..    | 1.068                       | 34.4                 | 68.8                   | 50         |
| TPD32-.../...-70-..<br>TPD32-.../...-56-..    | 0.611                       | 60.2                 | 120.4                  | 50         |
| TPD32-.../...-110-..<br>TPD32-.../...-88-..   | 0.398                       | 94.6                 | 189.2                  | 50         |
| TPD32-.../...-140-..<br>TPD32-.../...-112-..  | 0.305                       | 120.4                | 240.8                  | 50         |
| TPD32-.../...-185-..<br>TPD32-.../...-148-..  | 0.231                       | 159                  | 318                    | 50         |
| TPD32-.../...-280-..<br>TPD32-.../...-224-..  | 0.153                       | 241                  | 482                    | 50         |
| TPD32-.../...-350-..<br>TPD32-.../...-280-..  | 0.122                       | 301                  | 602                    | 50         |
| TPD32-.../...-420-..<br>TPD32-.../...-336-..  | 0.102                       | 361                  | 722                    | 50         |
| TPD32-.../...-500-..<br>TPD32-.../...-400-..  | 0.085                       | 430                  | 860                    | 50         |
| TPD32-.../...-650-..<br>TPD32-.../...-450-..  | 0.066                       | 559                  | 1118                   | 50         |
| TPD32-.../...-770-..<br>TPD32-.../...-560-..  | 0.056                       | 662                  | 1324                   | 50         |
| TPD32-.../...-1000-..<br>TPD32-.../...-800-.. | 0.043                       | 860                  | 1720                   | 50         |
| TPD32-.../...-1050-..<br>TPD32-.../...-850-.. | 0.041                       | 903                  | 1806                   | 50         |

#### 4.10.2 Interference suppression filters

The converters of TPD32 series must be equipped with an external EMI filter in order to reduce the radiofrequency emissions on the mains line. The filter selection is depending on the drive size and the installation environment. For this purpose see the “EMC Guidelines”.

In the Guide it is also indicated how to install the cabinet (connection of filter and mains reactors, cable shields, grounding, etc.), in order to make it EMC compliant according the EMC Directive 89/336/EEC.

The document describes the present situation concerning the EMC standards and the compliance tests made on the Gefran drives.

## 4.11 ENGINEERING NOTES

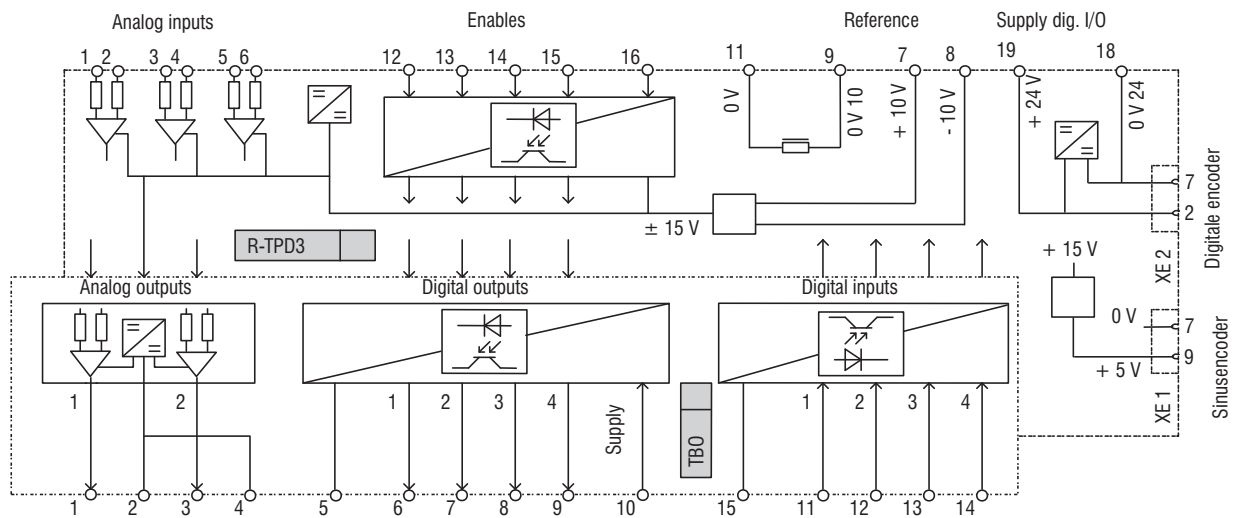

Figure 4.11.1: Potentials of the regulator section

### Potentials of the regulator section

The potentials of the regulator section are galvanic divided from the power section. Figure 4.11.1 shows their connection.

- The analog inputs are designed as differential.
- The enables are isolated from the regulation via optoisolators. The terminals 12 to 15 have terminal 16 as a common reference potential.
- The internal potential 0V is connected to terminal 11. In the majority of the cases the interference suppression is decreased!
- The regulation card puts at your disposal the following power supplies, which have a common reference point:
  - + 10V and - 10V for the reference
  - + 24V for the power supply of the digital inputs and outputs
  - + 5V for the encoder power supply
- The analog outputs are divided from the internal potential through a differential amplifier. The two outputs of the option card have the same potential (terminal 22 and 24 of TBO option card). When the TBO option card is used, the potential of the analog outputs are divided. For a better interference suppression and for the “cleaning” of the output signals, the terminals 2 and 4 of the TBO option card are directly ground connected (terminal 10 and /or 20 of the R-TPD3 card) or via a 0.1µF/250V capacitor.
- The digital outputs have the same potential (terminal 37) but they are divided from the regulator internal potential via optoisolators. In order to use the outputs, it is necessary to connect a power supply voltage to the terminal 30.
- The digital inputs are divided from the regulator through optoisolators. The terminals 31 to 34 have terminal 37 as a common potential.

## ***External devices***

As for the installation of contactors, protection devices, chokes, filters and other external devices it is necessary to follow the indication given in the previous chapters. The same theory is valid for motors, encoders and tachometers.

## ***Connection cables***

The encoder shielded cable must be made of twisted pairs. The connection cables of the encoders and of the motors, if possible, should be connected directly to the device, without going through support terminal strips.

The shieldings of the signal conductors have to be ground connected on both sides. Anyway, for all analog and digital signals with very long connections (outside the electric board), it is suggested to have a ground connection only on the converter side, in order to avoid possible noises caused by the closing of the ground loops. In particular cases it could be necessary to connect the shielding on both sides, thus granting the point equipotentiality via suitable connection cables.

The encoder cable has to be made up of twisted loops with the global shielding connected to the ground on the converter side. Avoid to connect the shielding on the motor side connector. In particular cases (cable longer than 100 meters, strong electromagnetic noise), it could be necessary to use a cable with a shielding on every loop to be connected to the power supply ground. The global shielding has always to be ground connected.

# 5 - CONVERTER OPERATION

## 5.1 KEYPAD

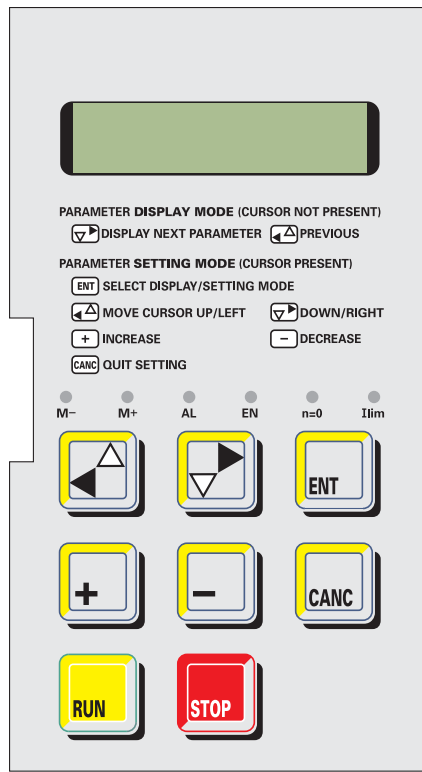

The keypad is made of a LCD display with two 16-digit lines and 8 function buttons. It is used

- to command the drive when this system has been selected
- to display the speed, the voltage and diagnostics during the operating time
- to set parameters

### 5.1.1 LEDs

The leds present on the keypad are used to diagnose in a fast way the functioning situation of the converter.

Table 5.1.1.1: Diagnostic LEDs

| Designation | Color  | Function  |
|-------------|--------|---|
| - Torque    | yellow | the LED is lit, when the drive operates with a negative torque (anti-clockwise rotation or clockwise braking). Only for TPD32-...-4B.         |
| + Torque    | yellow | the LED is lit, when the drive operates with a positive torque (clockwise rotation or anti-clockwise braking). Braking only for TPD32-...-4B. |
| Alarm       | red    | the LED is lit, it signals the intervention and the alarm condition   |
| Enable      | green  | the LED is lit, when the converter is enabled   |
| Zero Speed  | yellow | the LED is lit, when the motor speed is lower than the threshold set by Speed zero level  |
| I Limit     | yellow | the LED is lit, when the converter operates at a current limit  |

### 5.1.2 Moving inside a menu

- The DRIVE STATUS always appears when the converter is switched on.
- Use the ▲ and ▼ keys to select the individual points within the same menu level.
- Press the ENT key to enter the next menu level.
- Use the CANC key to return to the next higher menu level, irrespective of which menu point was selected. The appropriate menu of the next higher level will appear once the return has been made.

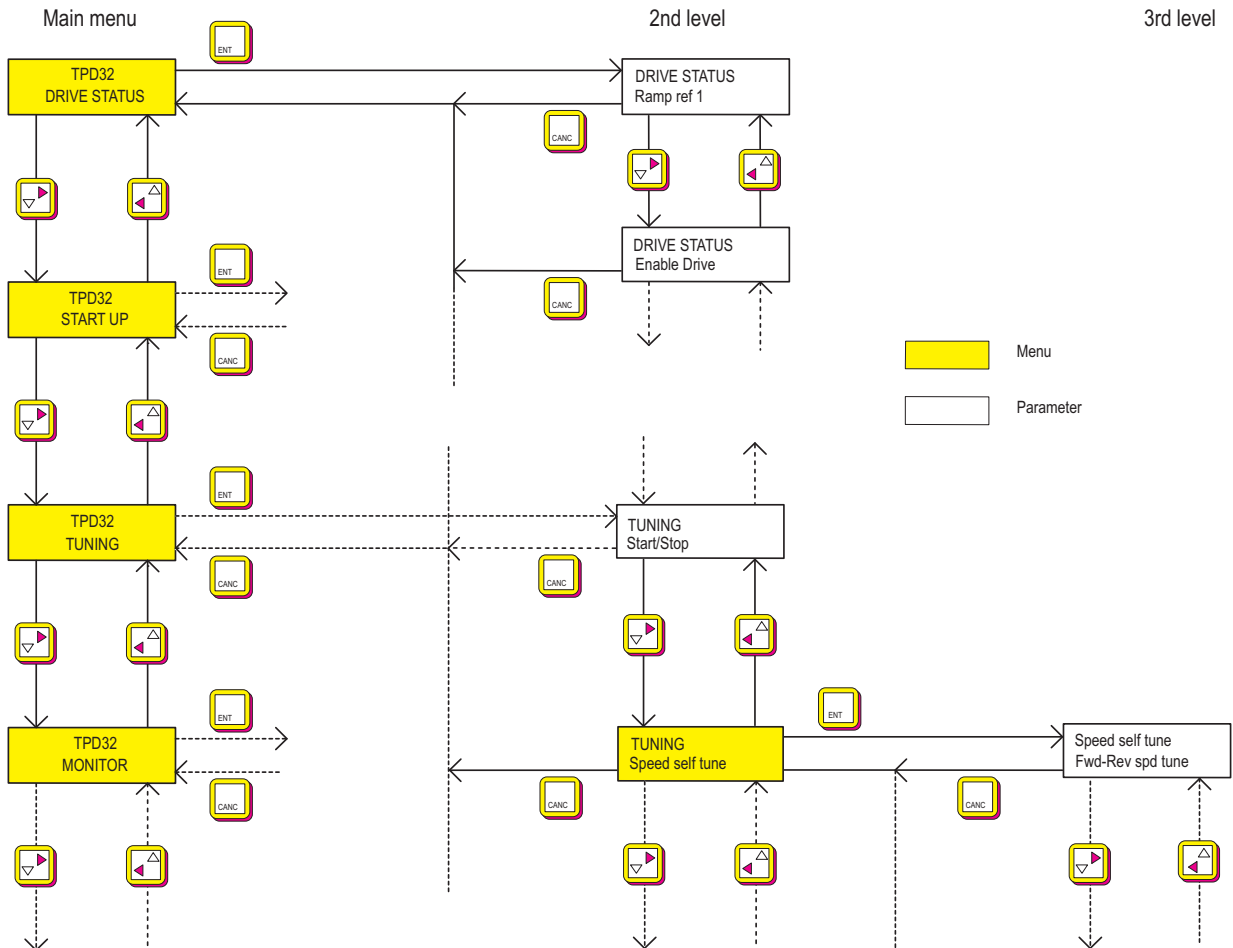
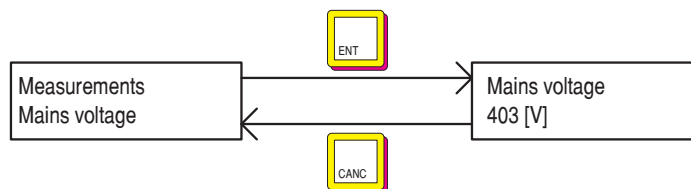

Figure 5.1.2.1: Moving inside a menu

### 5.1.3 Displaying parameters



- Select the parameters within the menu
- Press ENT. The parameter with its relative value will appear.
- Return to the menu using CANC.



## 5.1.4 Changing / Saving parameters / Password

The parameters with changeable values are divided into three groups:

- Parameters whose content is either selected as a number or as text within a defined range  
e.g. ramp times and reference values
- Parameters whose contents are fixed values that can be selected.  
e.g. **Jog selection** with the “speed input” and “Ramp input” alternatives.
- Parameters that are automatically scaled by the keypad  
e.g. **Auto tune inp XX**

**Note!** Only those parameters that are not assigned to a digital or analog input/output can be changed with the keypad. The changed parameters must be saved otherwise the previous values will be loaded the next time the device is switched on.

### Changing numerical values and text

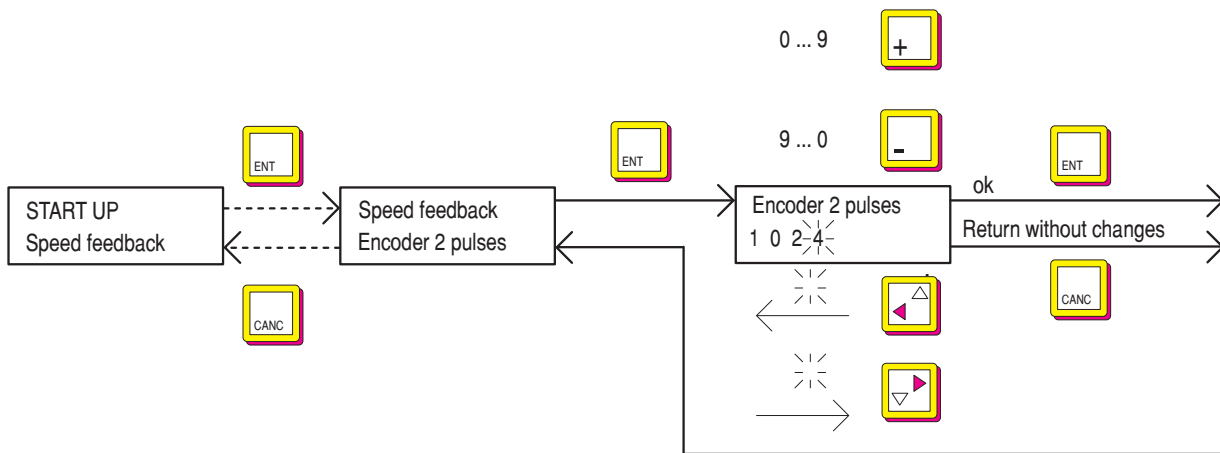

- Select within the menu the parameters to be changed.
- Press ENT. The value of the parameter will appear and the last digit will flash. The value of the flashing digit is always the one that can be changed.
- Increase the value with +
- Reduce the value with -
- Select the next digit left with ◀
- Select the next digit right with ▶
- Confirm the new value and return to the previous display by pressing ENT.
- Press CANC to return without changes.

**Note!** When setting the **Dim factor text** parameter, the following characters are also available in addition to the numbers: / % & + , - . : < = > ? A...Z [ ] a...z

## Selection from predefined values

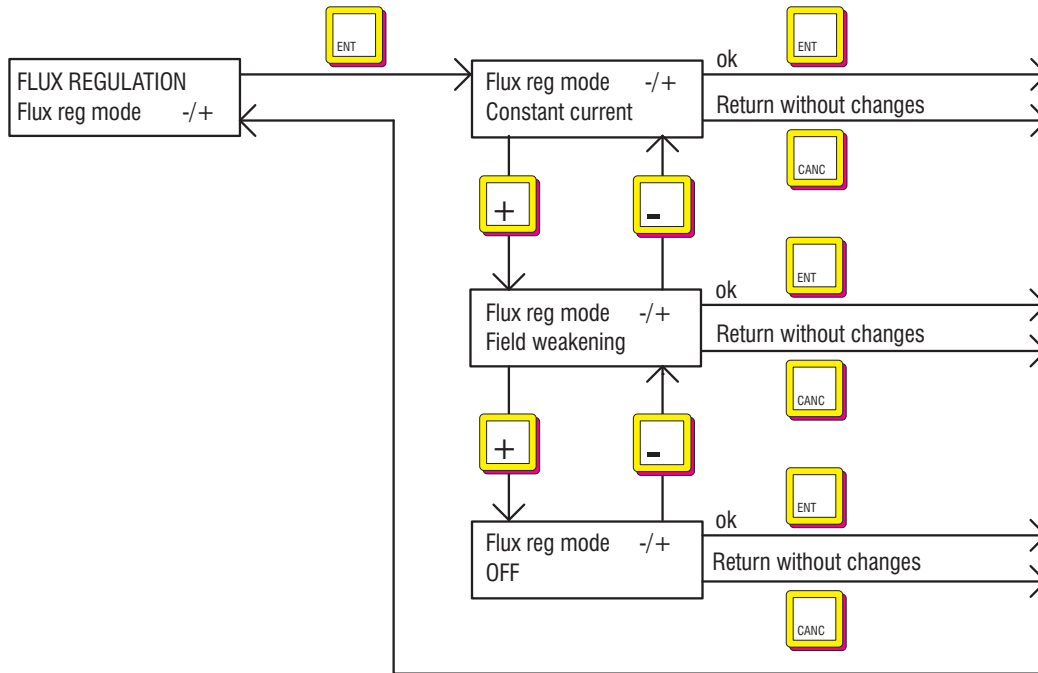

- The parameters that can be selected among the several possibilities are marked with -/+ on the keypad display.
- To change a value press ENT. The current value is shown in the display. This can be changed with the + and - keys.
- Confirm the new value and return to the previous display by pressing ENT.
- Return without changes via CANCEL

## Autotuning of Analog input

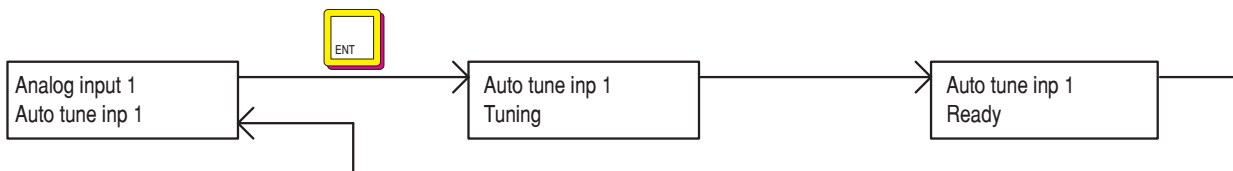

- Select the parameter **Auto tune input XX**.
- Press ENT
- The tuning procedure will run automatically. The messages “Tuning” and “Ready” will appear in succession before the original parameter is shown.

### Note!

The maximum signal possible must be present on the analog input concerned during the tuning procedure.

## Parameters Saving

The parameters must be saved, otherwise the previous values will be loaded the next time the device is switched on.

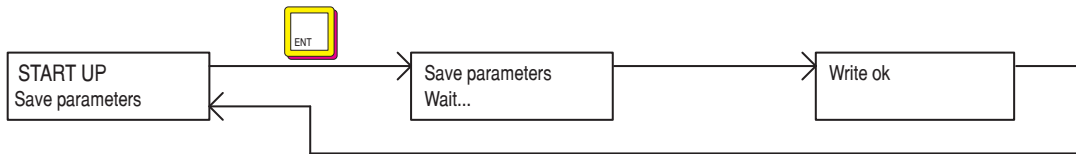

- Select **Save parameters** in the START UP or in the SPEC FUNCTIONS menu.
- Press ENT
- The saving operation is automatic. The messages “Wait ...” and “Write ok” will appear in succession before the original parameter is shown.

## Entering a password

The operator can define a password consisting of a freely selectable five-digit number combination in order to protect the keypad from unauthorized access. This is carried out via the **Pword 1** parameter.

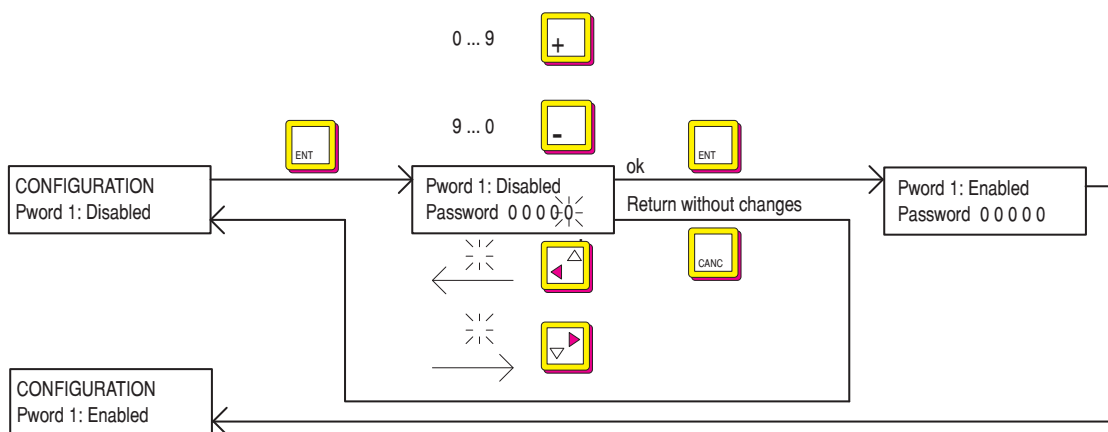

- Select **Pword1** (= Password 1) in the CONFIGURATION menu.
- Press ENT. The value 00000 will appear with the last digit flashing. The value of the flashing digit is changed.
- Increase the numerical value with +
- Reduce the numerical value with -
- Select the next digit left with ◀
- Select the next digit right with ▶
- Confirm the password by pressing ENT. The message: Pword1: Enabled will then appear shortly with the currently valid password displayed.
- The existing password is indicated in the CONFIGURATION menu via the “Pword 1: Enabled” message.
- Press the CANC key in order to abort the entry of the password.

**Note!** The password must be saved with **Save parameters** so that it is also active the next time the device is switched on.

## General unlocking of the password

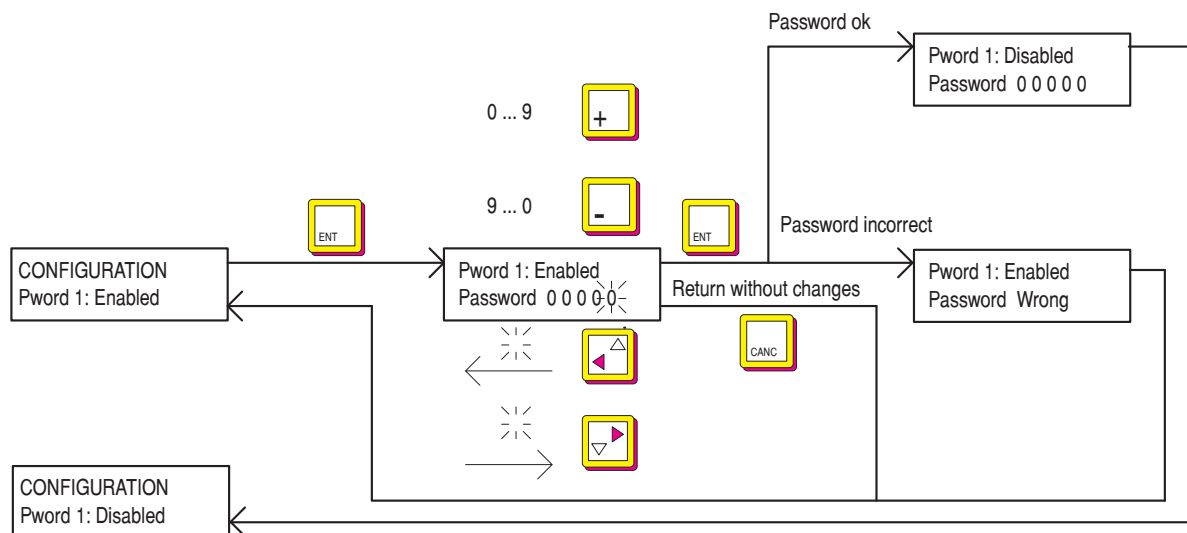

- Select the parameter **Pword1** (= Password 1) in the CONFIGURATION menu.
- When the password is enabled, the message “Pword 1: Enabled” appears
- Press ENT to call the value 00000 with the last digit flashing. The value changed is always the digit that is flashing. The valid password must be re-entered in order to unlock it.
- Increase the numerical value with +
- Reduce the numerical value with -
- Select the next digit left with ◀
- Select the next digit right with ▶
- Confirm the password by pressing ENT. The message: Pword1: Enabled will then appear for a short time.
- The existing password is indicated in the CONFIGURATION menu via the “Pword 1: Enabled” message.
- Press the CANCEL key in order to abort the entry of the password if required.
- If the incorrect password is entered and then the ENT key pressed, the message “Password wrong” will appear and the keypad will return to the CONFIGURATION menu with the display “Pword1: Enabled”

**Note!** The **Save parameter** function must be used to save the password if the password itself must not only be disabled but completely unlocked.

### 5.1.5 Operating the drive via the Keypad

In order to operate the drive via the keypad, the following settings must be done :

|                                 |                            |         |
|---------------------------------|----------------------------|---------|
| START UP and CONFIGURATION menu | Set <b>Main commands</b> = | Digital |
| MENU CONFIGURATION              | Set <b>Control Mode</b> =  | Local   |

- The hardware enables on terminals 12...15 are also active when the drive is operated via the keypad. This means, for example, that the signal at terminal 13 must also be present for starting the drive in addition to the command via the keypad.
- If the drive is stopped via the keypad, it can be restarted simply by pressing the Start Key.
- If the stop was caused by removing the voltage signal on terminal 13, both the signal at terminal 13 and the command via the keypad are necessary to restart the drive. The signal at the terminals must be present before giving the keypad command.
- The same applies accordingly to the enabling of the drive via the **Enable drive** parameter.

### 5.1.5.1 Starting and stopping the drive

**Note:** The keypad must be enabled (see section 6.11.1) before performing these actions.

#### Enabling the converter

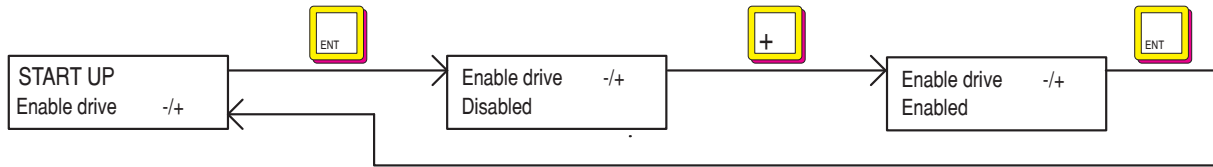

- Select the parameter Enable drive in the DRIVE STATUS or START UP or MONITOR menu.
- Press ENT
- Use the key + to choose “Disabled” or “Enabled”.
- Press ENT to confirm your entry.

#### Disabling the converter

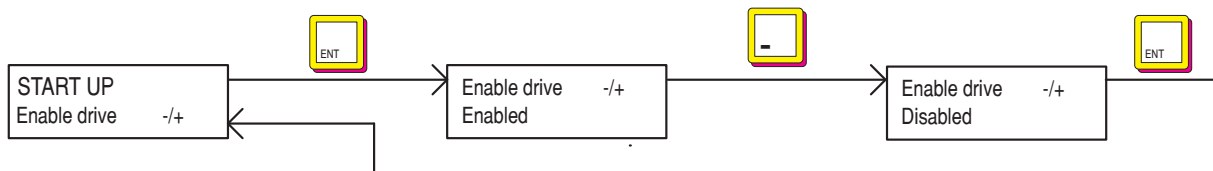

- Select the parameter Enable drive in the DRIVE STATUS or START UP or MONITOR menu.
- Press ENT
- Use the key - to change the display from “Enabled” into “Disabled”.
- Press ENT to confirm your entry.

#### Start / Stop

**Warning:** The keypad STOP can be used only when **Main commands** parameter is set to digital.



- Start: press the Start key.
- Stop: press the STOP key.

### 5.1.5.2 Failure register / Acknowledging alarms

#### Display of the failure register

- Select the parameter **Failure register** in the SPEC FUNCTIONS menu.
- Press ENT. The last error that has occurred will be displayed.
- Using the key + it is possible to display the previous alarm.
- The failure register can take up to 10 values. If a new failure is reported, the oldest entry in the failure register is overwritten.
- The entries in the failure register are retained until the register is cleared.
- Pressing ENT the time when the alarm occurred will be displayed. The time refers to the converter functioning period (presence of the supply voltage).
- After displaying, the menu goes back automatically to the **Failure register point**.
- By pressing the key CANC during the alarm display, the intervention time is not shown but on the contrary you go back to the **Failure register menu**.

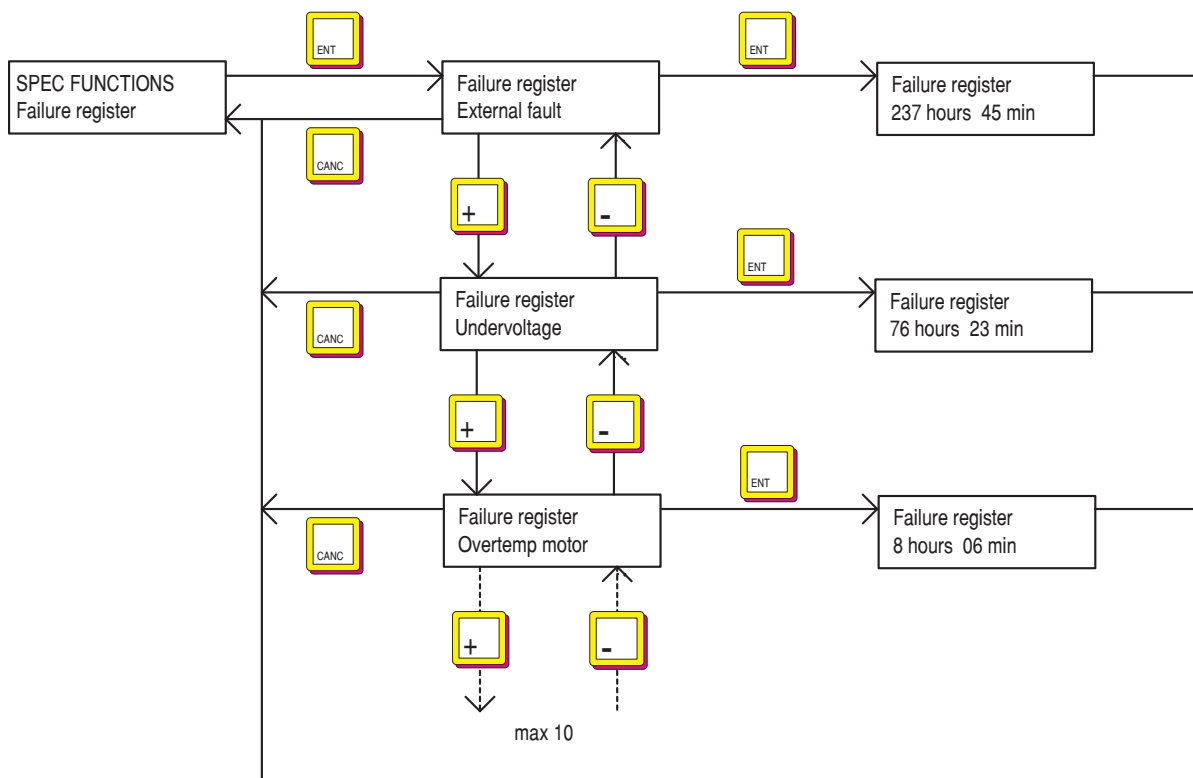

#### Clearing the failure register

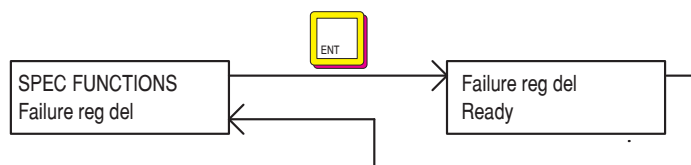

- Select the parameter **Failure reg del** in the SPEC FUNCTIONS menu.
- Press ENT. The failure register is cleared.

## Acknowledging a failure alarm

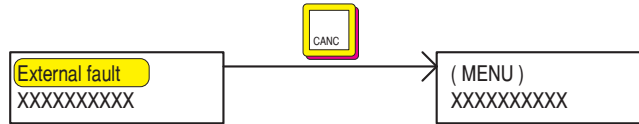

- If a failure occurs, the appropriate failure alarm will appear in the display and the message will flash.
- Acknowledge or reset the failure by pressing the CANC key. The converter must be disabled for this and a Start command must not be present.

## Acknowledging when several failure alarms occur at the same time



- When several failure alarms occur at the same time, the blinking message “Multi failures” will appear in the display.
- Select the parameter **Failure reset** in the SPEC FUNCTIONS menu.
- Press the CANC key to acknowledge or reset the failure alarm. The converter must be disabled for this and there should be no Start command present.

### 5.1.5.3 Motor potentiometer function

**Note!** To use the motor potentiometer function, this must be enabled with the **Enable motor pot** parameter!

## Acceleration, Deceleration

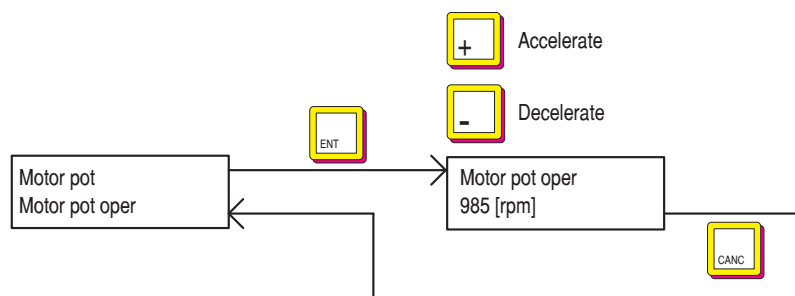

- Select the Motor pot oper parameter in the “Motor pot” submenu.
- Pressing ENT the current reference value is displayed.
- Press the + key to increase the reference value and accelerate the drive.
- Press the - key to decrease the reference value and decelerate the drive. This applies to both rotation directions.
- Press CANC to return to the “Motor pot” submenu.

## Changing rotation direction

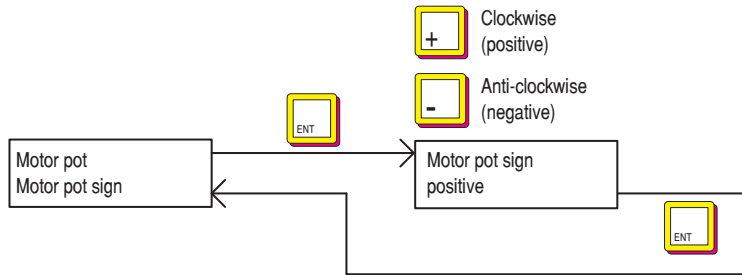

- Select the **Motor pot sign** parameter in the “Motor pot” submenu.
- Pressing ENT the current rotation direction is displayed.
- Press the + key to select clockwise rotation and the - key for counterclockwise rotation.
- Confirm by pressing ENT.
- Changing the **Motor pot sign** parameter during operation causes the drive to reverse rotation according to the ramp times set.

## Resetting the speed reference value

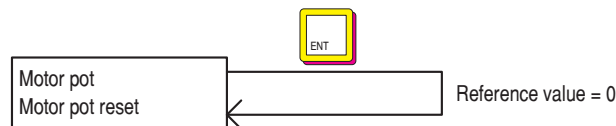

- Select the **Motor pot reset** parameter in the “Motor pot” submenu.
- Press ENT. The reference speed is set to zero.

**Note!** The speed reference value can only be reset when the drive is switched off.

### 5.1.5.4 Jog function

**Note!** The Jog function must be enabled via the Enable jog parameter!

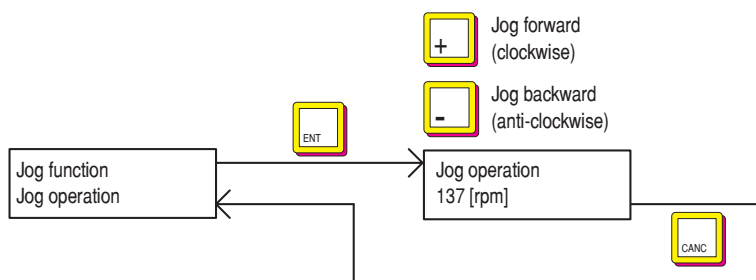

- Select the **Jog operation** parameter in the “Jog function” submenu.
- Press ENT. The selection Jog function is displayed.
- Press the + key to select clockwise rotation and the - key for counterclockwise rotation.
- Press CANC to return to the “Jog function” submenu.



## 5.2 MENU STRUCTURE

The menu consists of a main menu with submenus and parameters. The structure can be compared to the organization of files and subdirections on a PC.

|       |           |   |
|-------|-----------|---|
| TPD32 | main menu | corresponds PC main menu (main menu = Root) |
| TPD32 | submenu   | corresponds to PC submenu                   |
| TPD32 | parameter | corresponds to individual parameters        |

The menu structure is described in the function description given in section 6, "Function description". The following conventions apply:

|            |                               |
|------------|-------------------------------|
| Main menu: | Black field, text in capitals |
| Submenu:   | Black field                   |
| Parameter  | White field                   |

|                        |
|------------------------|
| <b>DRIVE STATUS</b>    |
| <b>START UP</b>        |
| <b>TUNING</b>          |
| <b>MONITOR</b>         |
| <b>INPUT VARIABLES</b> |
| <b>LIMITS</b>          |
| <b>RAMP</b>            |
| <b>SPEED REGULAT</b>   |
| <b>CURRENT REGULAT</b> |
| <b>FLUX REGULATION</b> |
| <b>REG PARAMETERS</b>  |
| <b>CONFIGURATION</b>   |
| <b>I/O CONFIG</b>      |
| <b>ADD SPEED FUNCT</b> |
| <b>FUNCTIONS</b>       |
| <b>SPEC FUNCTIONS</b>  |
| <b>OPTIONS</b>         |
| <b>DRIVECOM</b>        |
| <b>SERVICE</b>         |

**DRIVE STATUS**

|        |                    |
|--------|--------------------|
| [44]   | Ramp ref 1 [FF]    |
| [314]  | Enable drive       |
| [315]  | Start/Stop         |
| [233]  | Output voltage [V] |
| [199]  | Motor current [%]  |
| [122]  | Actual spd (rpm)   |
| [118]  | Speed ref (rpm)    |
| [1052] | Output power [kW]  |
| [351]  | Flux current (A)   |
| [466]  | Mains voltage [V]  |
|        | Digital I/Q        |

**START UP**

|       |                       |
|-------|-----------------------|
| [45]  | Speed base value [FF] |
| [374] | Nom flux curr [A]     |
| [499] | Speed-0 f weak        |
| [21]  | Acc delta speed [FF]  |
| [22]  | Acc delta time [s]    |
| [29]  | Dec delta speed [FF]  |
| [30]  | Dec delta time [s]    |

**Motor data**

|       |                       |
|-------|-----------------------|
| [280] | Motor nom flux [A]    |
| [469] | Flux reg mode         |
| [179] | Full load curr [A]    |
| [162] | Motor max speed [rpm] |
| [175] | Max out voltage [V]   |
| [456] | Flux weak speed [%]   |

**Limits**

|       |                       |
|-------|-----------------------|
| [7]   | T current lim [%]     |
| [468] | Flux current min [%]  |
| [467] | Flux current max [%]  |
| [1]   | Speed min amount [FF] |
| [2]   | Speed max amount [FF] |

**Speed feedback**

|       |                  |
|-------|------------------|
| [414] | Speed fbk sel    |
| [562] | Tacho scale      |
| [563] | Speed offset     |
| [169] | Encoder 2 pulses |
| [457] | Enable fbk contr |
| [652] | Refresh enc 2    |

**Alarms**

|       |                     |
|-------|---------------------|
| [481] | Undervolt thr [V]   |
| [584] | Overcurrent thr [%] |

| <b>Overload contr</b>  |                      |
|------------------------|----------------------|
| [309]                  | Enable overload      |
| [318]                  | Overload mode        |
| [312]                  | Overload current [%] |
| [313]                  | Base current [%]     |
| [310]                  | Overload time [s]    |
| [1289]                 | Motor ovrlld preal.  |
| [655]                  | Motor I2t accum      |
| [1438]                 | Drive ovrlld preal.  |
| [1439]                 | Drive I2t accum      |
| [311]                  | Pause time [s]       |
| <b>Analog inputs</b>   |                      |
| <b>Analog input 1</b>  |                      |
| [70]                   | Select input 1       |
| [72]                   | Scale input 1        |
| [259]                  | Auto tune inp 1      |
| [74]                   | Offset input 1       |
| <b>Analog input 2</b>  |                      |
| [75]                   | Select input 2       |
| [77]                   | Scale input 2        |
| [260]                  | Auto tune inp 2      |
| [79]                   | Offset input 2       |
| <b>Analog input 3</b>  |                      |
| [80]                   | Select input 3       |
| [82]                   | Scale input 3        |
| [261]                  | Auto tune inp 3      |
| [84]                   | Offset input 3       |
| [452]                  | R&L Search           |
| [314]                  | Enable drive         |
| [315]                  | Start/Stop           |
| <b>Speed self tune</b> |                      |
| [1029]                 | Fwd-Rev spd tune     |
| [1048]                 | Test T curr lim [%]  |
| [1027]                 | Start                |
| [1014]                 | Inertia [kg*m*m*]    |
| [1030]                 | Inertia Nw [kg*m*m*] |
| [1015]                 | Friction [N*m]       |
| [1031]                 | Friction Nw [N*m]    |
| [87]                   | Speed P [%]          |
| [1032]                 | Speed P Nw [%]       |
| [88]                   | Speed I [%]          |
| [1033]                 | Speed I Nw [%]       |
| [1028]                 | Take val             |
| [252]                  | Main commands        |
| [253]                  | Control mode         |
| [256]                  | Save parameters      |

**TUNING**

|       |              |
|-------|--------------|
| [452] | R&L Search   |
| [314] | Enable drive |
| [315] | Start/Stop   |

**Speed self tune**

|        |                      |
|--------|----------------------|
| [1029] | Fwd-Rev spd tune     |
| [1048] | Test T curr lim [%]  |
| [1027] | Start                |
| [1014] | Inertia [kg*m*m*]    |
| [1030] | Inertia Nw [kg*m*m*] |
| [1015] | Friction [N*m]       |
| [1031] | Friction Nw [N*m]    |
| [87]   | Speed P [%]          |
| [1032] | Speed P Nw [%]       |
| [88]   | Speed I [%]          |
| [1033] | Speed I Nw [%]       |
| [1028] | Take val             |

|       |                  |
|-------|------------------|
| [87]  | Speed P [%]      |
| [88]  | Speed I [%]      |
| [444] | Prop filter [ms] |
| [91]  | Flux P [%]       |
| [92]  | Flux I [%]       |
| [493] | Voltage P [%]    |
| [494] | Voltage I [%]    |
| [256] | Save parameters  |

**MONITOR**

|       |              |
|-------|--------------|
| [314] | Enable drive |
| [315] | Start/Stop   |

**Measurements****Speed****Speed in DRC**

|       |                      |
|-------|----------------------|
| [109] | Ramp ref (d) [FF]    |
| [112] | Ramp output (d) [FF] |
| [115] | Speed ref (d) [FF]   |
| [119] | Actual spd (d) [FF]  |
| [925] | F act spd (d) [FF]   |
| [923] | Act spd filter [s]   |

**Speed in rpm**

|       |                    |
|-------|--------------------|
| [110] | Ramp ref (rpm)     |
| [113] | Ramp outp (rpm)    |
| [118] | Speed ref (rpm)    |
| [122] | Actual spd (rpm)   |
| [427] | Enc 1 speed (rpm)  |
| [420] | Enc 2 speed (rpm)  |
| [924] | F act spd (rpm)    |
| [923] | Act spd filter [s] |

**Speed in %**

|       |                 |
|-------|-----------------|
| [111] | Ramp ref (%)    |
| [114] | Ramp output (%) |
| [117] | Speed ref (%)   |
| [121] | Actual spd (%)  |

|        |                      |
|--------|----------------------|
| [466]  | Mains voltage [V]    |
| [588]  | Mains frequency [Hz] |
| [1052] | Output power [Kw]    |
| [233]  | Output voltage [V]   |
| [199]  | Motor current [%]    |
| [928]  | F T curr (%)         |
| [926]  | T curr filter [s]    |
| [41]   | T current ref [%]    |
| [500]  | Flux reference [%]   |
| [234]  | Flux current %       |
| [351]  | Flux current (A)     |

**I/O**

|       |                 |
|-------|-----------------|
|       | Digital I/Q     |
| [582] | Virtual dig inp |
| [583] | Virtual dig out |

**INPUT VARIABLES****Ramp ref****Ramp ref 1**

|      |                 |
|------|-----------------|
| [44] | Ramp ref 1 [FF] |
| [47] | Ramp ref 1 (%)  |

**Ramp ref 2**

|      |                 |
|------|-----------------|
| [48] | Ramp ref 2 [FF] |
| [49] | Ramp ref 2 (%)  |

**Speed ref****Speed ref 1**

|       |                  |
|-------|------------------|
| [42]  | Speed ref 1 [FF] |
| [378] | Speed ref 1 (%)  |

**Speed ref 2**

|       |                  |
|-------|------------------|
| [43]  | Speed ref 2 [FF] |
| [379] | Speed Ref 2 (%)  |

**T current ref**

|      |                     |
|------|---------------------|
| [39] | T current ref 1 [%] |
| [40] | T current ref 2 [%] |

**LIMITS****Speed limits****Speed amount**

|     |                       |
|-----|-----------------------|
| [1] | Speed min amount [FF] |
| [2] | Speed max amount [FF] |

**Speed min/max**

|     |                    |
|-----|--------------------|
| [5] | Speed min pos [FF] |
| [3] | Speed max pos [FF] |
| [6] | Speed min neg [FF] |
| [4] | Speed max neg [FF] |

**Current limits**

|       |                      |
|-------|----------------------|
| [715] | T current lim type   |
| [7]   | T current lim [%]    |
| [8]   | T current lim + [%]  |
| [9]   | T current lim - [%]  |
| [10]  | In use Tcur lim+ [%] |
| [11]  | In use Tcur lim- [%] |
| [13]  | Current lim red [%]  |
| [342] | Torque reduct        |

**Flux limits**

|       |                      |
|-------|----------------------|
| [467] | Flux current max [%] |
| [468] | Flux current min [%] |

**RAMP****Acceleration**

|      |                      |
|------|----------------------|
| [21] | Acc delta speed [FF] |
| [22] | Acc delta time [s]   |

**Deceleration**

|      |                      |
|------|----------------------|
| [29] | Dec delta speed [FF] |
| [30] | Dec delta time [s]   |

**Quick stop**

|      |                       |
|------|-----------------------|
| [37] | QStp delta speed [FF] |
| [38] | QStp delta time [s]   |

|       |                      |
|-------|----------------------|
| [18]  | Ramp shape           |
| [19]  | S shape t const [ms] |
| [663] | S acc t const [ms]   |
| [664] | S dec t const [ms]   |
| [20]  | Ramp +/- delay [ms]  |
| [673] | Fwd-Rev              |
| [245] | Enable ramp          |
| [344] | Ramp out = 0         |
| [345] | Ramp in = 0          |
| [373] | Freeze ramp          |

**SPEED REGULAT**

|        |                      |
|--------|----------------------|
| [118]  | Speed ref [rpm]      |
| [236]  | Speed reg output [%] |
| [322]  | Lock speed reg       |
| [242]  | Enable spd reg       |
| [348]  | Lock speed I         |
| [1016] | Aux spd fun sel      |
| [444]  | Prop filter [ms]     |

**Self tuning**

|        |                      |
|--------|----------------------|
| [1029] | Fwd-Rev spd tune     |
| [1048] | Test T curr lim [%]  |
| [1027] | Start                |
| [1014] | Inertia [kg*m*m*]    |
| [1030] | Inertia Nw [kg*m*m*] |
| [1015] | Friction [N*m]       |
| [1031] | Friction Nw [N*m]    |
| [87]   | Speed P [%]          |
| [1032] | Speed P Nw [%]       |
| [88]   | Speed I [%]          |
| [1033] | Speed I Nw [%]       |
| [1028] | Take val             |

**Spd zero logic**

|       |                  |
|-------|------------------|
| [123] | Enable spd=0 I   |
| [124] | Enable spd=0 R   |
| [125] | Enable spd=0 P   |
| [126] | Spd=0 P gain [%] |
| [106] | Ref 0 level [FF] |

**Speed up**

|       |                      |
|-------|----------------------|
| [445] | Speed up gain [%]    |
| [446] | Speed up base [ms]   |
| [447] | Speed up filter [ms] |

**Droop function**

|       |                   |
|-------|-------------------|
| [696] | Droop gain [%]    |
| [697] | Droop filter [ms] |
| [698] | Load comp [%]     |
| [700] | Droop limit [FF]  |
| [699] | Enable droop      |

**Inertia/loss cp**

|        |                       |
|--------|-----------------------|
| [1014] | Inertia [kg*m*m*]     |
| [1015] | Friction [N*m]        |
| [1013] | Torque const [N*m/A]  |
| [1012] | Inertia c filter [ms] |



**CURRENT REGULAT**

|        |                       |
|--------|-----------------------|
| [41]   | T current ref [%]     |
| [199]  | Motor current [%]     |
| [1430] | Mot cur threshld [%]  |
| [1431] | Mot cur th delay [ms] |
| [1520] | dI/dt delta time      |
| [453]  | Arm resistance [ ]    |
| [454]  | Arm inductance [mH]   |
| [587]  | E int [V]             |
| [452]  | R&L Search            |
| [353]  | Zero torque           |

**FLUX REGULATION**

|       |                    |
|-------|--------------------|
| [497] | Enable flux reg    |
| [469] | Flux reg mode      |
| [498] | Enable flux weak   |
| [499] | Speed-0 f weak     |
| [500] | Flux reference [%] |
| [234] | Flux current %     |
| [921] | Out vlt level      |

**Flux \ if curve**

|       |                    |
|-------|--------------------|
| [916] | I field cnst 40    |
| [917] | I field cnst 70    |
| [918] | I field cnst 90    |
| [919] | Set flux / if      |
| [920] | Reset flux / if    |
| [374] | Nom flux curr [A]  |
| [280] | Motor nom flux [A] |

**REG PARAMETERS****Percent values****Speed regulator**

|       |                    |
|-------|--------------------|
| [87]  | Speed P [%]        |
| [88]  | Speed I [%]        |
| [459] | Speed P bypass [%] |
| [460] | Speed I bypass [%] |

**Flux regulator**

|      |            |
|------|------------|
| [91] | Flux P [%] |
| [92] | Flux I [%] |

**Voltage reg**

|       |               |
|-------|---------------|
| [493] | Voltage P [%] |
| [494] | Voltage I [%] |

**Base values****Speed regulator**

|      |                         |
|------|-------------------------|
| [93] | Speed P base [A/rpm]    |
| [94] | Speed I base [A/rpm.ms] |

**Flux regulator**

|      |             |
|------|-------------|
| [97] | Flux P base |
| [98] | Flux I base |

**Voltage reg**

|       |                          |
|-------|--------------------------|
| [495] | Voltage P base [f%/V]    |
| [496] | Voltage I base [f%/V.ms] |

**In use values**

|       |                    |
|-------|--------------------|
| [99]  | Speed P in use [%] |
| [100] | Speed I in use [%] |

**CONFIGURATION**

|        |                       |
|--------|-----------------------|
| [252]  | Main commands         |
| [253]  | Control mode          |
| [45]   | Speed base value [FF] |
| [179]  | Full load curr [A]    |
| [175]  | Max out voltage [V]   |
| [412]  | Ok relay funct        |
| [1521] | En TCurr HiRes        |

**Speed fbk**

|       |                       |
|-------|-----------------------|
| [162] | Motor max speed [rpm] |
| [414] | Speed fbk sel         |
| [457] | Enable fbk contr      |
| [458] | Enable fbk bypas      |
| [456] | Flux weak speed [%]   |
| [455] | Speed fbk error [%]   |
| [562] | Tacho scale           |
| [563] | Speed offset          |
| [416] | Encoder 1 pulses      |
| [169] | Encoder 2 pulses      |
| [649] | Refresh enc 1         |
| [652] | Refresh enc 2         |
| [911] | Enable ind store      |

**Drive type**

|       |                  |
|-------|------------------|
| [465] | Drive size [A]   |
| [201] | 2B + E           |
| [464] | Size selection   |
| [331] | Software version |

**Dimension fact**

|      |                 |
|------|-----------------|
| [50] | Dim factor num  |
| [51] | Dim factor den  |
| [52] | Dim factor text |

**Face value fact**

|      |                |
|------|----------------|
| [54] | Face value num |
| [53] | Face value den |

**Prog alarms****Failure supply**

|       |               |
|-------|---------------|
| [194] | Latch         |
| [195] | Ok relay open |

**Undervoltage**

|       |                    |
|-------|--------------------|
| [481] | Undervolt thr [V]  |
| [357] | Latch              |
| [358] | Ok relay open      |
| [470] | Hold off time [ms] |
| [359] | Restart time [ms]  |

| <b>Overvoltage</b>      |                            |
|-------------------------|----------------------------|
|                         | [203] Activity             |
|                         | [361] Latch                |
|                         | [362] Ok relay open        |
|                         | [482] Hold off time [ms]   |
|                         | [483] Restart time [ms]    |
| <b>Overspeed</b>        |                            |
|                         | [1426] Overspeed thr [rpm] |
|                         | [1422] Activity            |
|                         | [1421] Latch               |
|                         | [1423] Ok relay open       |
|                         | [1424] Hold off time [ms]  |
|                         | [1425] Restart time [ms]   |
| <b>Heatsink</b>         |                            |
|                         | [368] Activity             |
|                         | [370] Ok relay open        |
| <b>Overtemp motor</b>   |                            |
|                         | [365] Activity             |
|                         | [367] Ok relay open        |
| <b>External fault</b>   |                            |
|                         | [354] Activity             |
|                         | [355] Latch                |
|                         | [356] Ok relay open        |
|                         | [502] Hold off time [ms]   |
|                         | [501] Restart time [ms]    |
| <b>Brake fault</b>      |                            |
|                         | [1296] Activity            |
|                         | [1297] Ok relay open       |
| <b>Motor I2t ovrlld</b> |                            |
|                         | [1419] Activity            |
|                         | [1442] Latch               |
|                         | [1420] Ok relay open       |
| <b>Drive I2t ovrlld</b> |                            |
|                         | [1441] Ok relay open       |
| <b>Overcurrent</b>      |                            |
|                         | [584] Overcurrent thr [%]  |
|                         | [212] Activity             |
|                         | [363] Latch                |
|                         | [364] Ok relay open        |
|                         | [586] Hold off time [ms]   |
|                         | [585] Restart time [ms]    |

| <b>Field loss</b>      |         |                      |
|------------------------|---------|----------------------|
|                        | [473]   | Activity             |
|                        | [471]   | Latch                |
|                        | [472]   | Ok relay open        |
|                        | [475]   | Hold off time [ms]   |
|                        | [474]   | Restart time [ms]    |
| <b>Delta frequency</b> |         |                      |
|                        | [1437]  | Delta freq thres [%] |
|                        | [1432]  | Activity             |
|                        | [1433]  | Latch                |
|                        | [1434]  | Ok relay open        |
|                        | [1435]  | Hold off time [ms]   |
|                        | [1436]  | Restart time [ms]    |
| <b>Speed fbk loss</b>  |         |                      |
|                        | [478]   | Activity             |
|                        | [477]   | Ok relay open        |
|                        | [480]   | Hold off time [ms]   |
| <b>Opt2 failure</b>    |         |                      |
|                        | [639]   | Activity             |
|                        | [640]   | Ok relay open        |
| <b>Bus loss</b>        |         |                      |
|                        | [634]   | Activity             |
|                        | [633]   | Latch                |
|                        | [635]   | Ok relay open        |
|                        | [636]   | Hold off time [ms]   |
|                        | [637]   | Restart time [ms]    |
| <b>Hw opt1 failure</b> |         |                      |
|                        | [386]   | Activity             |
|                        | [387]   | Ok relay open        |
| <b>Enable seq err</b>  |         |                      |
|                        | [728]   | Activity             |
|                        | [729]   | Latch                |
|                        | [730]   | Ok relay open        |
| <b>Set serial comm</b> |         |                      |
|                        | [319]   | Device address       |
|                        | [408]   | Ser answer delay     |
|                        | [323]   | Ser protocol sel     |
|                        | [326]   | Ser baudrate sel     |
| [85]                   | Pword 1 |                      |

**I/O CONFIG****Analog outputs****Analog output 1**

|      |                 |
|------|-----------------|
| [66] | Select output 1 |
| [62] | Scale output 1  |

**Analog output 2**

|      |                 |
|------|-----------------|
| [67] | Select output 2 |
| [63] | Scale output 2  |

**Analog output 3**

|      |                 |
|------|-----------------|
| [68] | Select output 3 |
| [64] | Scale output 3  |

**Analog output 4**

|      |                 |
|------|-----------------|
| [69] | Select output 4 |
| [65] | Scale output 4  |

**Analog inputs****Analog input 1**

|        |                     |
|--------|---------------------|
| [70]   | Select input 1      |
| [295]  | An in 1 target      |
| [71]   | Input 1 type        |
| [389]  | Input 1 sign        |
| [72]   | Scale input 1       |
| [73]   | Tune value inp 1    |
| [259]  | Auto tune inp 1     |
| [792]  | Input 1 filter [ms] |
| [1042] | Input 1 compare     |
| [1043] | Input 1 cp error    |
| [1044] | Input 1 cp delay    |
| [74]   | Offset input 1      |

**Analog input 2**

|       |                     |
|-------|---------------------|
| [75]  | Select input 2      |
| [296] | An in 2 target      |
| [76]  | Input 2 type        |
| [390] | Input 2 sign        |
| [77]  | Scale input 2       |
| [78]  | Tune value inp 2    |
| [260] | Auto tune inp 2     |
| [801] | Input 2 filter [ms] |
| [79]  | Offset input 2      |

**Analog input 3**

|       |                     |
|-------|---------------------|
| [80]  | Select input 3      |
| [297] | An in 3 target      |
| [81]  | Input 3 type        |
| [391] | Input 3 sign        |
| [82]  | Scale input 3       |
| [83]  | Tune value inp 3    |
| [261] | Auto tune inp 3     |
| [802] | Input 3 filter [ms] |
| [84]  | Offset input 3      |

**Digital outputs**

|        |                   |
|--------|-------------------|
| [145]  | Digital output 1  |
| [1267] | Inversion out 1   |
| [146]  | Digital output 2  |
| [1268] | Inversion out 2   |
| [147]  | Digital output 3  |
| [1269] | Inversion out 3   |
| [148]  | Digital output 4  |
| [1270] | Inversion out 4   |
| [149]  | Digital output 5  |
| [1271] | Inversion out 5   |
| [150]  | Digital output 6  |
| [1272] | Inversion out 6   |
| [151]  | Digital output 7  |
| [1273] | Inversion out 7   |
| [152]  | Digital output 8  |
| [1274] | Inversion out 8   |
| [629]  | Relay 2           |
| [1275] | Inversion relay 2 |

**Digital inputs**

|        |                 |
|--------|-----------------|
| 137    | Digital input 1 |
| [1276] | Inversion in 1  |
| [138]  | Digital input 2 |
| [1277] | Inversion in 2  |
| [139]  | Digital input 3 |
| [1278] | Inversion in 3  |
| [140]  | Digital input 4 |
| [1279] | Inversion in 4  |
| [141]  | Digital input 5 |
| [1280] | Inversion in 5  |
| [142]  | Digital input 6 |
| [1281] | Inversion in 6  |
| [143]  | Digital input 7 |
| [1282] | Inversion in 7  |
| [144]  | Digital input 8 |
| [1283] | Inversion in 8  |

**Encoder inputs**

|        |                  |
|--------|------------------|
| [1020] | Select enc 1     |
| [1021] | Select enc 2     |
| [416]  | Encoder 1 pulses |
| [169]  | Encoder 2 pulses |
| [649]  | Refresh enc 1    |
| [652]  | Refresh enc 2    |

**ADD SPEED FUNCT**

|       |              |
|-------|--------------|
| [388] | Auto capture |
|-------|--------------|

**Adaptive spd reg**

|        |                     |
|--------|---------------------|
| [181]  | Enable spd adap     |
| [182]  | Select adap type    |
| [183]  | Adap reference [FF] |
| [1464] | Adap selector       |
| [184]  | Adap speed 1 [%]    |
| [185]  | Adap speed 2 [%]    |
| [186]  | Adap joint 1 [%]    |
| [187]  | Adap joint 2 [%]    |
| [188]  | Adap P gain 1 [%]   |
| [189]  | Adap I gain 1 [%]   |
| [190]  | Adap P gain 2 [%]   |
| [191]  | Adap I gain 2 [%]   |
| [192]  | Adap P gain 3 [%]   |
| [193]  | Adap I gain 3 [%]   |
| [1462] | Adap P gain 4 [%]   |
| [1463] | Adap I gain 4 [%]   |

**Speed control**

|       |                      |
|-------|----------------------|
| [101] | Spd threshold + [FF] |
| [102] | Spd threshold - [FF] |
| [103] | Threshold delay [ms] |
| [104] | Set error [FF]       |
| [105] | Set delay [ms]       |

**Speed zero**

|       |                       |
|-------|-----------------------|
| [107] | Speed zero level [FF] |
| [108] | Speed zero delay [ms] |



**FUNCTIONS**

|                        |       |                       |
|------------------------|-------|-----------------------|
| <b>Motor pot</b>       |       |                       |
|                        | [246] | Enable motor pot      |
|                        | [247] | Motor pot oper        |
|                        | [248] | Motor pot sign        |
|                        | [249] | Motor pot reset       |
| <b>Jog function</b>    |       |                       |
|                        | [244] | Enable jog            |
|                        | [265] | Jog operation         |
|                        | [375] | Jog selection         |
|                        | [266] | Jog reference [FF]    |
| <b>Multi speed fct</b> |       |                       |
|                        | [153] | Enab multi spd        |
|                        | [154] | Multi speed 1 [FF]    |
|                        | [155] | Multi speed 2 [FF]    |
|                        | [156] | Multi speed 3 [FF]    |
|                        | [157] | Multi speed 4 [FF]    |
|                        | [158] | Multi speed 5 [FF]    |
|                        | [159] | Multi speed 6 [FF]    |
|                        | [160] | Multi speed 7 [FF]    |
|                        | [208] | Multispeed sel        |
| <b>Multi ramp fct</b>  |       |                       |
|                        | [243] | Enab multi rmp        |
|                        | [202] | Ramp selector         |
| <b>Multi ramp fct</b>  |       |                       |
| <b>Ramp 0</b>          |       |                       |
| <b>Acceleration 0</b>  |       |                       |
|                        | [659] | Acc delta speed0 [FF] |
|                        | [660] | Acc delta time 0 [s]  |
|                        | [665] | S acc t const 0 [ms]  |
| <b>Deceleration 0</b>  |       |                       |
|                        | [661] | Dec delta speed0 [FF] |
|                        | [662] | Dec delta time 0 [s]  |
|                        | [666] | S dec t const 0 [ms]  |
| <b>Ramp 1</b>          |       |                       |
| <b>Acceleration 1</b>  |       |                       |
|                        | [23]  | Acc delta speed1 [FF] |
|                        | [24]  | Acc delta time 1 [s]  |
|                        | [667] | S acc t const 1 [ms]  |
| <b>Deceleration 1</b>  |       |                       |
|                        | [31]  | Dec delta speed1 [FF] |
|                        | [32]  | Dec delta time 1 [s]  |
|                        | [668] | S dec t const 1 [ms]  |
| <b>Ramp 2</b>          |       |                       |
| <b>Acceleration 2</b>  |       |                       |
|                        | [25]  | Acc delta speed2 [FF] |
|                        | [26]  | Acc delta time 2 [s]  |
|                        | [669] | S acc t const 2 [ms]  |
| <b>Deceleration 2</b>  |       |                       |
|                        | [33]  | Dec delta speed2 [FF] |
|                        | [34]  | Dec delta time 2 [s]  |
|                        | [670] | S dec t const 2 [ms]  |

**Ramp 3****Acceleration 3**

|       |                       |
|-------|-----------------------|
| [27]  | Acc delta speed3 [FF] |
| [28]  | Acc delta time 3 [s]  |
| [671] | S acc t const 3 [ms]  |

**Deceleration 3**

|       |                       |
|-------|-----------------------|
| [35]  | Dec delta speed3 [FF] |
| [36]  | Dec delta time 3 [s]  |
| [672] | S dec t const 3 [ms]  |

**Speed draw**

|        |                    |
|--------|--------------------|
| [1017] | Speed ratio        |
| [1018] | Speed draw out (d) |
| [1019] | Speed draw out (%) |

**Overload contr**

|        |                      |
|--------|----------------------|
| [309]  | Enable overload      |
| [318]  | Overload mode        |
| [312]  | Overload current [%] |
| [313]  | Base current [%]     |
| [310]  | Overload time [s]    |
| [1289] | Motor ovrl d preal.  |
| [655]  | Motor I2t accum      |
| [1438] | Drive ovrl d preal.  |
| [1439] | Drive I2t accum      |
| [311]  | Pause time [s]       |

**Stop control**

|       |                       |
|-------|-----------------------|
| [626] | Stop mode             |
| [627] | Spd 0 trip delay [ms] |
| [628] | Trip cont delay [ms]  |
| [630] | Jog stop control      |

**Brake control**

|        |                     |
|--------|---------------------|
| [1295] | Enable Torque pr    |
| [1262] | Closing speed [rpm] |
| [1293] | Torque delay [ms]   |
| [1294] | Torque proving [%]  |
| [1266] | Actuator delay [ms] |

**I/n curve**

|       |                 |
|-------|-----------------|
| [750] | I/n curve       |
| [751] | I/n lim 0 [%]   |
| [752] | I/n lim 1 [%]   |
| [753] | I/n lim 2 [%]   |
| [754] | I/n lim 3 [%]   |
| [755] | I/n lim 4 [%]   |
| [756] | I/n speed [rpm] |

**SPEC FUNCTIONS**
**Test generator**

|       |                      |
|-------|----------------------|
| [58]  | Generator access     |
| [59]  | Gen frequency [Hz]   |
| [60]  | Gen amplitude [%]    |
| [61]  | Generator offset [%] |
| [256] | Save parameters      |
| [258] | Load default         |
| [235] | Life time [h.min]    |
| [330] | Failure register     |
| [262] | Failure reset        |
| [263] | Failure reg del      |

**Links**
**Link 1**

|       |               |
|-------|---------------|
| [484] | Source        |
| [485] | Destination   |
| [486] | Mul gain      |
| [487] | Div gain      |
| [488] | Input max     |
| [489] | Input min     |
| [490] | Input offset  |
| [491] | Output offset |
| [492] | Inp absolute  |

**Link 2**

|       |               |
|-------|---------------|
| [553] | Source        |
| [554] | Destination   |
| [555] | Mul gain      |
| [556] | Div gain      |
| [557] | Input max     |
| [558] | Input min     |
| [559] | Input offset  |
| [560] | Output offset |
| [561] | Inp absolute  |

**Link 3**

|        |               |
|--------|---------------|
| [1218] | Source        |
| [1219] | Destination   |
| [1220] | Mul gain      |
| [1221] | Div gain      |
| [1222] | Input max     |
| [1223] | Input min     |
| [1224] | Input offset  |
| [1225] | Output offset |
| [1226] | Inp absolute  |

| Link 4 |               |
|--------|---------------|
| [1227] | Source        |
| [1228] | Destination   |
| [1229] | Mul gain      |
| [1230] | Div gain      |
| [1231] | Input max     |
| [1232] | Input min     |
| [1233] | Input offset  |
| [1234] | Output offset |
| [1235] | Inp absolute  |

| Link 5 |               |
|--------|---------------|
| [1236] | Source        |
| [1237] | Destination   |
| [1238] | Mul gain      |
| [1239] | Div gain      |
| [1240] | Input max     |
| [1241] | Input min     |
| [1242] | Input offset  |
| [1243] | Output offset |
| [1244] | Inp absolute  |

| Link 6 |               |
|--------|---------------|
| [1245] | Source        |
| [1246] | Destination   |
| [1247] | Mul gain      |
| [1248] | Div gain      |
| [1249] | Input max     |
| [1250] | Input min     |
| [1251] | Input offset  |
| [1252] | Output offset |
| [1253] | Inp absolute  |

**Pad Parameters**

|       |               |
|-------|---------------|
| [503] | Pad 0         |
| [504] | Pad 1         |
| [505] | Pad 2         |
| [506] | Pad 3         |
| [507] | Pad 4         |
| [508] | Pad 5         |
| [509] | Pad 6         |
| [510] | Pad 7         |
| [511] | Pad 8         |
| [512] | Pad 9         |
| [513] | Pad 10        |
| [514] | Pad 11        |
| [515] | Pad 12        |
| [516] | Pad 13        |
| [517] | Pad 14        |
| [518] | Pad 15        |
| [519] | Bitword pad A |
| [536] | Bitword pad B |

| OPTIONS               |                            |
|-----------------------|----------------------------|
| <b>Option 1</b>       |                            |
| <b>Option 2</b>       |                            |
|                       | Menu                       |
| [425]                 | Enable OPT2                |
| <b>PID</b>            |                            |
| [769]                 | Enable PI PID              |
| [770]                 | Enable PD PID              |
| <b>PID source</b>     |                            |
|                       | [786] PID source           |
|                       | [787] PID source gain      |
|                       | [758] Feed-fwd PID         |
| <b>PID references</b> |                            |
|                       | [759] PID error            |
|                       | [763] PID feed-back        |
|                       | [762] PID offs. Sel        |
|                       | [760] PID offset 0         |
|                       | [761] PID offset 1         |
|                       | [1046] PID acc time        |
|                       | [1047] PID dec time        |
|                       | [757] PID clamp            |
| <b>PI controls</b>    |                            |
|                       | [765] PI P gain PID        |
|                       | [764] PI I gain PID        |
|                       | [695] PI steady thr        |
|                       | [731] PI steady delay      |
|                       | [793] P init gain PID      |
|                       | [734] I init gain PID      |
|                       | [779] PI central v sel     |
|                       | [776] PI central v1        |
|                       | [777] PI central v2        |
|                       | [778] PI central v3        |
|                       | [784] PI top lim           |
|                       | [785] PI bottom lim        |
|                       | [783] PI integr freeze     |
|                       | [771] PI output PID        |
|                       | [418] Real FF PID          |
| <b>PD control</b>     |                            |
|                       | [768] PD P gain 1 PID [%]  |
|                       | [766] PD D gain 1 PID [%]  |
|                       | [788] PD P gain 2 PID [%]  |
|                       | [789] PD D gain 2 PID [%]  |
|                       | [790] PD P gain 3 PID [%]  |
|                       | [791] PD D gain 3 PID [%]  |
|                       | [767] PD D filter PID [ms] |
|                       | [421] PD output PID        |
|                       | [772] PID out sign PID     |
|                       | [774] PID output           |

| PID target |               |
|------------|---------------|
| [782]      | PID target    |
| [773]      | PID out scale |

| Diameter calc |                       |
|---------------|-----------------------|
| [794]         | Diameter calc         |
| [795]         | Positioning spd [rpm] |
| [796]         | Max deviation         |
| [797]         | Gear box ratio        |
| [798]         | Dancer constant [mm]  |
| [799]         | Minimum diameter [cm] |

### Torque winder

|        |                  |
|--------|------------------|
| [1209] | Torque winder En |
|--------|------------------|

| Diam Calculatio |                       |
|-----------------|-----------------------|
| [1154]          | Roll diameter [m]     |
| [1160]          | Line speed [%]        |
| [1286]          | Ref line speed [%]    |
| [1161]          | Diam calc Dis         |
| [1205]          | Diam inc/dec En       |
| [1187]          | Wind/unwind           |
| [799]           | Minimum diameter [mm] |
| [1153]          | Maximum diameter [m]  |
| [1204]          | Line spd source       |
| [1284]          | Ref spd source        |
| [1156]          | Line speed gain       |
| [1285]          | Ref speed gain        |
| [1163]          | Base omega [rpm]      |
| [1155]          | Ref speed thr [%]     |
| [1162]          | Diam filter [ms]      |
| [1206]          | Diam init filter [ms] |
| [1207]          | Diam stdy delay [ms]  |
| [1157]          | Diam reset            |
| [1158]          | Diam thr [%]          |
| [1159]          | Diam reached          |
| [1168]          | Diam preset sel       |
| [1164]          | Diam preset 0 [m]     |
| [1165]          | Diam preset 1 [m]     |
| [1166]          | Diam preset 2 [m]     |
| [1167]          | Diam preset 3 [m]     |

| Torque calculat |                     |
|-----------------|---------------------|
| [1180]          | Tension ref [%]     |
| [1181]          | Tension scale [%]   |
| [1194]          | Act tension ref [%] |
| [1193]          | Torque current [%]  |

**Comp calculat**

|        |                      |
|--------|----------------------|
| [1183] | Int acc calc En      |
| [1182] | Time acc/dec min [s] |
| [1212] | Acc/dec filter [ms]  |
| [1184] | Line acc [%]         |
| [1185] | Line dec [%]         |
| [1186] | Line fast stop [%]   |
| [1188] | Line acc status      |
| [1189] | Line dec status      |
| [1190] | Line fstp status     |
| [1171] | Variable J comp [%]  |
| [1172] | Constant J comp [%]  |
| [1192] | Act var J comp [%]   |
| [1191] | Act const J comp [%] |
| [1173] | Mat width [%]        |
| [1174] | Static f [%]         |
| [1175] | Dinamic f [%]        |
| [1287] | Static f Zero        |
| [1213] | Actual comp [%]      |
| [1214] | Closed loop En       |
| [1208] | Close loop comp      |

**Taper function**

|        |                     |
|--------|---------------------|
| [1176] | Taper enable        |
| [1177] | Init diameter [m]   |
| [1178] | Final diameter [m]  |
| [1180] | Tension ref [%]     |
| [1179] | Tension red [%]     |
| [1194] | Act tension ref [%] |

**Speed demand**

|        |                      |
|--------|----------------------|
| [1215] | Speed demand En      |
| [1201] | Winder side          |
| [1202] | W gain [%]           |
| [1195] | Speed match          |
| [1200] | Spd match gain [%]   |
| [1196] | Spd match acc [s]    |
| [1197] | Spd match dec [s]    |
| [1203] | Spd match compl      |
| [1216] | Spd match torque [%] |
| [1199] | W offset [rpm]       |
| [1198] | Offset acc time [s]  |
| [1210] | W target             |
| [1217] | W reference [rpm]    |
| [1256] | Jog TW enable        |
| [1255] | Jog TW speed [%]     |

**DRIVECOM**

|       |                      |
|-------|----------------------|
| [57]  | Malfunction code     |
| [55]  | Control word         |
| [56]  | Status word          |
| [44]  | Speed input var [FF] |
| [115] | Speed ref var [FF]   |
| [119] | Act speed value [FF] |

**Speed amount**

|     |                       |
|-----|-----------------------|
| [1] | Speed min amount [FF] |
| [2] | Speed max amount [FF] |

**Speed min/max**

|     |                    |
|-----|--------------------|
| [5] | Speed min pos [FF] |
| [3] | Speed max pos [FF] |
| [6] | Speed min neg [FF] |
| [4] | Speed max neg [FF] |

**Acceleration**

|      |                      |
|------|----------------------|
| [21] | Acc delta speed [FF] |
| [22] | Acc delta time [s]   |

**Deceleration**

|      |                      |
|------|----------------------|
| [29] | Dec delta speed [FF] |
| [30] | Dec delta time [s]   |

**Quick stop**

|      |                       |
|------|-----------------------|
| [37] | QStp delta speed [FF] |
| [38] | QStp delta time [s]   |

**Face value fact**

|      |                |
|------|----------------|
| [54] | Face value num |
| [53] | Face value den |

**Dimension fact**

|      |                 |
|------|-----------------|
| [50] | Dim factor num  |
| [51] | Dim factor den  |
| [52] | Dim factor text |

|       |                       |
|-------|-----------------------|
| [45]  | Speed base value [FF] |
| [46]  | Speed input perc [%]  |
| [116] | Percent ref var [%]   |
| [120] | Act percentage [%]    |

**SERVICE**

|            |
|------------|
| Password 2 |
|------------|



## 5.3 COMMISSIONING

**Warning!** The safety instructions, danger warnings and technical data in Section 1 and 2 of this manual must be observed!

**Definitions:** **Positive speed** is clockwise rotation seen from the motor shaft end side.  
**Negative Speed** is counter-clockwise rotation seen from the motor shaft end side.  
**Positive torque** is torque in clockwise direction seen from the motor shaft end side.  
**Negative torque** is torque in counter-clockwise direction seen from the motor shaft end side.

### 5.3.1 Setting jumpers and switch

The hardware configuration set via the jumpers and switches on the R-TPD32 regulator card must be adapted to the application at hand and checked **before switching on the device**.

- Analog inputs 1/2/3
  - Voltage input 0... 10V Jumper S9/S10/S11 = OFF
  - Current voltage 0...20 mA / 4...20 mA Jumper S9/S10/S11 = ON
  - Mixed possible configuration
- Adaptation for the speed feedback type
  - Sinusoidal Encoder Jumper S5/S6 in position A
  - Digital Encoder Jumper S5/S6 any position
  - Analog tachometer generator Jumper S5/S6 in position B
  - Armature reaction Jumper S5/S6 any position
- Adaptation for the digital encoder voltage
  - Voltage = 5 V Jumper S21/S22/S23 = ON
  - Voltage = 15...30 V Jumper S21/S22/S23 = OFF
- Control of a digital encoder connected to the connector XE2
  - Channel C controlled Jumper S20 = ON
  - Channel C not controlled Jumper S20 = OFF
- Adaptation of the max voltage using a tachometer generator:
  - 22.7 / 45.4 / 90.7 / 181.6 / 302.9 V, depending on the dip switch S4 setting (see chapter 4.4.3)
- Serial interface RS485
  - On the first and last drop of a line: Jumper S12 / S13 = ON
  - On the other converters Jumper S12 / S13 = OFF
- RS485 serial interface
  - divided from the regulation Jumper S18 / S19 in position OFF  
(An external 5 V power supply is needed on the PINs 5 and 9) see section 4.5.2
  - with a common potential 0 V of the regulation Jumper S18 / S19 in position ON  
(Internal power supply)

For further information see section 4.4, "Regulation section".

### 5.3.2 Checking the wiring and the auxiliary voltages

The following should be checked before switching on the device:

- Proper connection of cables (Section 4, “Wiring procedures”)
- Compliance with Section 4.11, “Engineering notes”
- When the device current limit is not set according to the rated current value of the connected motor, a protection thermal relay must be inserted in the upper part of the converter, which has to be scaled according to the motor rated current times 0.86.

**Warning!** It is not allowed to connect an external voltage on the converter output.

- Drive disabled (disconnect the terminal 12)
- The following voltages must be present:
  - terminal 7 + 10V to terminal 9
  - terminal 8 - 10V to terminal 9
  - terminal 19 + 24 ... 30V to terminal 18
- Select the **Actual spd (rpm)** parameter in the DRIVE STATUS menu.
  - With a disabled regulator turn the motor in a clockwise direction (view facing the shaft). The displayed value must be positive.
  - If the value does not change or if wrong values are shown, check the power supply and the cabling of the encoder/tachometer.
  - If the displayed value is negative, the connections of the encoder or of the tachometer generator must be changed: channel A+ with A- or B+ with B- of the encoder, change the connections of the tachometer signal.

### 5.3.3 Basic settings of the converter

#### **Note!**

It is assumed that the device has the default configuration and is connected and tested according to the diagrams provided in section 4.8, “Standard connection diagrams”. The default setting can be loaded via the **Load default** parameter in the SPEC FUNCTIONS menu. Loading this parameter will mean that all modifications carried out by the user will be overwritten. An exception is represented by the **Tacho scale** and **Speed parameters**. These are not overwritten when the factory set values are loaded and it is not necessary to scale again the input signal of the tachometer section. The same is valid for the **Size selection** parameter.

The factory setting allows a speed regulation with the cascade current regulation for a DC motor, with an independent excitation and provided with a digital encoder. The drive, in this case, does not operate with a Voltage control. Independently of the desired configuration, it is advised to carry out all the basic settings described in order to avoid possible mistakes. After the commissioning all other available functions can be activated. Their setting is described in the following pages.

The possible values set for each parameter can be found in section 10, “Parameter lists”.

The following settings must be carried out with the disabled converter.

**Enable drive** = disabled (no voltage on the terminal12).

See section 5.1, “Keypad”, for information about operating the keypad.

#### **Selection of the drive command (via terminals or digital)**

- When the converter is controlled only via the terminal strip, set the **Main commands** parameter to “Terminals”. Before change this parameter set be sure that no voltage is supplied to terminal 12.
- When the keypad is used **Main commands** = Digital

#### **Saving Settings**

- Use **Save parameters** in SPECIAL FUNCTION menu
- User parameters setting must be saved into memory, so that the stored values are read the next time the device is switched on.
- When using the keypad: press ENT.

On standard setting, to perform the self tuning of current regulator during the commissioning, the **Main commands** parameter is set as “Digital”.

### 5.3.4 START UP procedures

Following START UP menu allows a quick basic commissioning of the drive.

|                             |  |
|-----------------------------|--|
| <b>Speed base value</b>     | This value determines the max rpm corresponding to the max signal applied to an analog input (e.g. 10V or 20mA).       |
| <b>Nom flux curr</b>        | Nominal field current of the drive. Set the range through the dip switches on the regulation board. See table 2.4.3.2. |
| <b>Speed-0 f weak</b>       | Enables Speed-0 f weak at zero speed.  |
| <b>Speed-0 f weak delay</b> | Sets a time delay.   |
| <b>Acc delta ...</b>        | Acceleration ramp time setting on the speed reference.   |
| <b>Dec delta ...</b>        | Deceleration ramp time setting on the speed reference.   |

#### Motor data

In this menu all the motor plate data are placed.

In case the speed self-tuning has to be carried out, such values must correspond to the motor nameplate data, as the motor torque constant derives right from them.

**Note !** Performing the speed regulator self tuning the following parameters must be set correctly according to the motor used.

|                        |  |
|------------------------|--|
| <b>Motor nom flux</b>  | Motor nom flux in Amps.  |
| <b>Flux reg mode</b>   | Flux regulator mode: constant current (fixed field) or Voltage control.  |
| <b>Full load curr</b>  | Nominal armature current in Amps. It corresponds to the 100% of the nominal drive output current. The default value is the nominal drive current. The settings for the current limits ( <b>T current limit</b> parameters) and the “ <i>Overload function</i> ” are based on this value. |
| <b>Motor max speed</b> | Maximum motor speed value. Set the motor plate data value.   |
| <b>Max out voltage</b> | Maximum armature voltage value. When Flux reg mode is set to fld weakening, it corresponds to the crossover point.   |
| <b>Flux weak speed</b> | <b>Motor max speed</b> percentage where the flux weakening range starts. (Crossover point)   |

**Note !** With speed regulator self tuning performed, the above parameters value can be changed.

#### Limits

This menu allows setting of speed limits value, current limits value and field current limits when different from the default values in *Motor data* menu.

|                         |   |
|-------------------------|---|
| <b>T current limit</b>  | Armature current limit value as percentage of <b>Full load curr</b> . When overload function is used this value must be equal or higher than <b>Overload current</b> parameter value (Overload function).   |
| <b>Flux current max</b> | Maximum field current value as percentage of <b>Motor nom flux</b> .  |
| <b>Flux current min</b> | Minimum field current value as percentage of <b>Motor nom flux</b> . It corresponds to the Speed-0 f weak current value when Speed-0 f weak function is active and it will be the lower field current limit value when the motor is running in Voltage control range. |
| <b>Speed min amount</b> | Minimum speed reference limit.  |
| <b>Speed max amount</b> | Maximum speed reference limit.  |

## **Speed feedback setting**

|                         |   |
|-------------------------|---|
| <b>Speed fbk sel</b>    | Speed feedback selection: encoder 1, encoder 2, tach generator, armature (CEMF).  |
| <b>Tacho scale</b>      | Tach generator feedback scaling ( <b>Speed fbk sel</b> must be set to <b>Tacho</b> )  |
| <b>Encoder 2 pulses</b> | Number of pulses per revolution of the digital encoder to the XE2 connector.  |
| <b>Enable fbk contr</b> | Speed feedback loss control. The <b>Motor max speed</b> , <b>Max out voltage</b> , <b>Flux weak speed</b> parameters must be set correctly according to the motor used. |
| <b>Refresh enc 2</b>    | Enable the monitoring of the encoder 2 (XE2 connector) connection status (A , B, Anot, Bnot channels). <b>Enable fbk contr</b> must be enabled.                         |

## **Alarms**

|                        |                                    |
|------------------------|------------------------------------|
| <b>Undervolt thr</b>   | AC input alarm threshold value.    |
| <b>Overcurrent thr</b> | Overcurrent alarm threshold value. |

## **Overload control**

The overload control function allows an overcurrent for a limited time that can exceed the rated current of the drive. It is used in order to provide an increased acceleration torque.(See Overload control function for more details).

## **Analog inputs 1, 2 and 3**

Three (3) differential analog inputs programmable are available (1-2, 3-4, 5-6 terminals) that allow a large number of configurations.

With the standard setting, analog input 1 (1 - 2 terminals) is set to **Ramp ref 1**. The other analog inputs are set to OFF.

## **5.3.5 Drive tuning**

### **5.3.5.1 Self tuning of the current regulator**

The following operation must be done before enabling the drive for the first time.

The autotuning of the current regulator is enabled via the **R&L Search** command. The values stated for the armature resistance and inductance are recorded as **Arm resistance** and **Arm inductance** (CURRENT REGULAT menu). If necessary the user can change these parameters value.

- If the motor field is externally power supplied (not from the drive), disconnect the motor field supply terminals. It is not necessary when the motor field power supply comes from the drive (C1 & D1 terminals)
- The user must be sure that during the current regulator self tuning the motor shaft does not turn (remanent magnetization, field series motor, etc.). If necessary, lock the motor shaft during the procedure.
- AC input voltage to U2 and V2 terminals,
- Drive disabled ( no +24 voltage at terminal 12 )
- Set **Main commands** parameter (START UP or CONFIGURATION menu) to “Digital” (Enable & Start/ stop command from the keypad).
- Set the Armature current desired via **T current lim +** (positive torque) and **T curent lim -** (Negative torque).
- Set Overload control function to disable. (**Enable overload** = Disabled).
- Set **R&L Search** command to ON (START UP menu)
- Power up the drive
- Power up U, V, W terminals
- Enable the drive (+24V to terminal 12) and Start (+24V to terminal 13 and 14).
- **Enable drive** command = ENABLE (START UP menu).

**Note!** If **Stop mode** parameter is not set to “OFF” (FUNCTIONS/Stop Control menu), press Start button on the keypad.

- The **R&L Search** takes a few minutes, and can be interrupted by powering off the drive or set **Enable drive** to disable.
- At the end of the current self tuning procedure the drive is automatically set to disabled and the **R&L Search** command to OFF.
- Set the **Enable drive** parameter to disabled (No voltage on terminal 12)
- Set **Main commands** parameter to the desired setting (Terminals or Digital).
- Set Overload control function to enable if used. (**Enable overload** = Enabled).
- Save setting via **Save parameters** command (START UP menu)

**Note!** The procedure can be interrupted by powering off the drive or set **Enable drive** to disable. The previous parameters setting are stored in the drive. It is not possible to start the procedure if the Enable drive is set to disable.

#### **5.3.5.1.1 Checking current regulator performance using parameter Eint**

While running the drive, monitor the parameter (**Eint**), located under menu heading “Current Regulator”. This measure an average internal current error.

Its value should be close to zero, but values dynamically changing between -40 and 40 are acceptable. **The drive must have at least 30% load for this reading to be considered as a valid performance measurement.** If adjustments are needed, make small changes to the parameter (Current regulator\Arm inductance) to fine tune (**Eint**) to an acceptable value.

- If **Eint** is positive value, increase “Arm inductance” value.
- If **Eint** is negative value, decrease “Arm inductance” value.

#### **5.3.5.2 Self tuning of the speed regulator**

**Speed Self tuning** identifies the total Inertia value at the motor shaft ( Kg\*m<sup>2</sup>), the friction value (or Loss compensation) in N\*m and computes the Proportional and Integral gains of the speed regulator.

**WARNING !** This procedure requires free rotation of the motor shaft coupled to the load. Start/Stop command is disregarded, therefore it can not be used on drives with limited travel.

**CAUTION !** The test is performed using the torque limit value set in **Test T curr lim** parameter. The torque is applied stepwise, with no ramp (profile), therefore the mechanical transmission must not have significant backlash, and it must be compatible with operation at the torque limit set in **Test T curr lim** parameter. The user can reduce the torque limit to a suitable value via the **Test T curr lim** parameter.

- Note !**
- Application where the system inertia coupled to the motor shaft is much higher than the motor inertia value , increase the **Test T curr lim** parameter to avoid “Time out” error.
  - This procedure is not suitable for use with “hoist” or “elevator” drives.

Preliminary operation before the correct execution of the Speed self tuning procedure is the appropriate calculation of the **Torque const** parameter.

Set the motor name plate data parameters:

|                            |  |
|----------------------------|--|
| <b>Motor max speed</b>     | Set the maximum motor speed value  |
| <b>Flux weak speed</b>     | <b>Motor max speed</b> percentage where the flux weakening range starts. (Crossover point) |
| <b>T Current limit +/-</b> | Set the nominal motor current value  |
| <b>Motor nom flux</b>      | Set the Motor nom flux in Amps.  |
| <b>Max out voltage</b>     | Set the maximum armature voltage value   |

With speed regulator self tuning performed, the above parameters value can be changed according to the application without **Torque const** parameter modification.

- Set the motor shaft direction: Forward or Reverse via the **Fwd-Rev spd tune** parameter
- Select the torque current value to be used during the test via the **Test T curr lim** parameter

**TO EXECUTE SELF TUNING**, enter START UP \ Self tuning menu.

- Start execution by entering **“Start”**.

The procedure performs an acceleration test at the torque limit value set in **Test T curr lim** parameter up to a speed threshold, then a deceleration test with no torque applied (coasting) down to zero speed.

The speed threshold is 33% of the lowest in the following:

- **Speed base value**
- **Speed max pos** or **Speed max neg** according to direction of rotation.

The procedure may take a few minutes, depending on inertia and friction values.

Based on inertia and friction values, the drive will calculate the speed loop gains (**Speed P** and **Speed I** parameters).

If manual adjustment are required (in case of vibrations, etc.) these should be applied to the integral gain **Speed I [%]**. In case self-tuning of speed regulator is not satisfactory, refer to manual tuning procedure in section 5.3.6 .

After the completion of the Speed self tune by the Drive, the new identified parameter values (“Nw” suffix) can be compared with values prior to the procedure, by browsing the subsequent menu entries. Parameters in this menu are read only. Editing of individual parameters must be done in their specific menus.

New parameters can be accepted all together by entering **“Take val”** after disabling the Drive. In this case, prior values are overwritten. **“Self tuning”** can be repeated, whether values from the previous trial have been accepted or not.

**Note!** **“Take val”** does not store values in non-volatile memory, so values are lost if Drive power is cycled off and on. You need to enter **Save parameters** in the START UP or SPEC FUNCTIONS menu to permanently store values in non-volatile memory.

In case of extreme parameter ranges, error messages can occur. Repeat execution in this case. If the error message is persistent, keep default values and use manual tuning of speed regulator (section 5.3.6 Manual tuning of the regulators).



## List of self tune error messages

### Generic messages

| Description         | Note   |
|---------------------|--|
| “Drive disabled”:   | Provide enable input by setting terminal 12 high.  |
| “Not ready”:        | “Take val” can not be executed because the measurement has not been completed correctly. Repeat self tune command. |
| “Time out”:         | Measurement has not been completed in the proper time  |
| “Start ?”:          | Press ENT to confirm start of measurement.   |
| “Tuning aborted”:   | Measurement aborted by user (CANC button has been pressed).  |
| “Set Main cmd=Dig”: | Go to CONFIGURATION menu and set <b>Main commands</b> = digital.   |
| “Set Ctrl=Local”:   | Go to CONFIGURATION menu and set <b>Control mode</b> = Local.  |

### Measurement error messages

These messages may occur when extreme parameter values have to be identified. It can be useful to retry the self tune command when any of the following messages occurs. If messages persist, alternative manual tuning procedures should be used.

| Description        | Note   |
|--------------------|--|
| “Over speed”       |  |
| “Drive stalled”:   | Increase value of parameter <b>Test T curr lim</b> and repeat <i>Self tuning</i>                             |
| “Load applied”:    | Nominal zero load torque at standstill was detected. <i>Self tuning</i> is impossible for this type of load. |
| “T curr too high”: | Reduce value of <b>Test T curr lim</b> parameter for <i>Self tuning</i>                                      |
| “Friction null”:   | Value of friction is zero or lower than the accuracy limit of the control system                             |

### 5.3.5.3 Field converter

The default TPD32 converters are set to operate without Voltage control. The following settings must be taken into consideration when a functioning in Voltage control is needed or when the field of the connected motor is not power supplied via the converter.

All the settings described in this chapter must be carried out in disable condition (no voltage on terminal 12).

### Selection of the functioning system

- With a constant field current: **Flux reg mode** = Constant current  
**Enable flux reg** = Enabled
- With Voltage control: **Flux reg mode** = Voltage control.  
In the CONFIGURATION menu set the max output voltage via the **Max out voltage** parameter.  
**Enable flux reg** = Enabled
- Field circuit not supplied by TPD32 **Flux reg mode** = OFF  
**Enable flux reg** = Disabled



## Setting the rated field current

- Set the rated field current of the motor via the **Motor nom flux** parameter.
- When the field motor current is substantially lower than the rated current of the field converter, adapt through the S14 dip switches the field converter. It must be configured according to the table 5.3.5.3.1. Via the **Nom flux curr** parameter it is possible to select the new field rated current.
- For fixed field current operation, if the actual motor (base) field current  $\leq 10\%$  of the maximum rating of the field package it is required to calibrate the field current feedback scaling using dipswitch S14.
- For weak field operation, also referred as “CEMF field control” or “crossover field control”, if the top base speed Motor nom flux  $\leq 10\%$  of the maximum rating of the field package it is required to calibrate the field current feedback scaling using dipswitch S14.

Calibration to the exact field current setting is not required, as long as the above conditions are met.

Calibration is not required if the field control is provided by a separate field converter.

Table 5.3.5.3.1: Tuning resistances of the field current

| Switch ohms   | 168.5 Ohm | 333 Ohm | 182 Ohm | 36.4 Ohm | 845 Ohm | 1668 Ohm |          |       | Equivalent resistance |
|---------------|-----------|---------|---------|----------|---------|----------|----------|-------|-----------------------|
| Nom flux curr | S14-1     | S14-2   | S14-3   | S14-4    | S14-5   | S14-6    | S14-7    | S14-8 |                       |
| 1.0 A         | OFF       | OFF     | OFF     | OFF      | OFF     | ON       | Not used |       | 1668 Ohm              |
| 2.0 A         | OFF       | OFF     | OFF     | OFF      | ON      | OFF      |          |       | 845 Ohm               |
| 3.0 A         | OFF       | OFF     | OFF     | OFF      | ON      | ON       |          |       | 560.9 Ohm             |
| 5.0 A         | OFF       | ON      | OFF     | OFF      | OFF     | OFF      |          |       | 333.3 Ohm             |
| 9.9 A         | ON        | OFF     | OFF     | OFF      | OFF     | OFF      |          |       | 168.5 Ohm             |
| 12.9 A        | ON        | OFF     | OFF     | OFF      | ON      | ON       |          |       | 129.6 Ohm             |
| 14.2 A        | OFF       | ON      | ON      | OFF      | OFF     | OFF      |          |       | 117.7 Ohm             |
| 17.1 A        | OFF       | ON      | ON      | OFF      | ON      | ON       |          |       | 97.3 Ohm              |
| 20.0 A        | ON        | OFF     | ON      | OFF      | OFF     | ON       |          |       | 83.1 Ohm              |
| 24.1 A        | ON        | ON      | ON      | OFF      | OFF     | OFF      |          |       | 69.3 Ohm              |
| 25.1 A        | ON        | ON      | ON      | OFF      | OFF     | ON       |          |       | 66.5 Ohm              |

## Flux current min/max

- Setting in LIMITS / Flux limits menu via the **Flux current max** and **Flux current min** parameters as a percentage of **Nom flux curr**.

### 5.3.6 Manual tuning of the regulators

The tuning of the TPD32 converters is factory set to a typical value for the motor size concerned. This normally ensures satisfactory regulator results. If this setting, however, meets the requirements of the application concerned, the regulator need not be optimized.

The converter contains the following close-loop control circuits:

- Regulator of the armature current. The auto tuning has to be perform via the **R&L Search** parameter.
- Speed regulator
- Field current regulator
- Armature voltage regulator

Following is a description of the system suitable to obtain the optimization, if necessary. In order to have a step function, the internal “Test generator” is used (“SPEC FUNCTIONS” menu). The aim is to obtain a very good step response.

The analog output can be brought back to the terminal strip, with a sampling time of 2 ms.

#### Using the Test generator

This function generates and makes available some signals with a square wave, with a frequency and a width that can be set and which can be added to an offset that can be set too. With the parameter **Gen access** it is possible to state on which regulator input the signal must be active. Further information can be found in section 6.15.1, “Test generator”.

#### Manual tuning of speed regulator

- No voltage on terminal 12 (Drive disabled)
- Choose the following settings for the Test generator :
  - **Gen access** = Ramp ref
  - **Gen frequency** = 0.2 Hz
  - **Gen amplitude** = 10 %
  - **Gen offset** = 10 %
- Measuring the reaction on an analog output. To this purpose “**Actual Spd**” and “**Motor current**” variables must be set on two different analog outputs (see “Programming inputs/outputs”).
- In the START UP menu set the **Acc delta speed** parameter with the highest value and the **Acc delta time** parameter at 1 second.
- Set at 0.00 the **Speed P** and **Speed I** parameters in the REG PARAMETERS / ...menu.
- Enable the drive (voltage on terminal 12) and Start (voltage on terminal 13).
- Increase the **Speed P** till when the overshoot is lower by 4% when the reaction time is shorter.
- Increase **Speed I** until the overshoot is higher by 4%. Decrease it, so that it is slightly lower than 4%.
- Stop and disable the drive (remove the voltage on terminal 12 and 13).
- **Gen access** = Not connected
- Save the settings (SAVE PARAMETERS command in the SPECIAL FUNCTION menu).

#### Note!

With the feedback “Bypass” function enabled (**Enable fbk bypas** = Enabled) the converter switch directly to the armature feedback (CEMF) when the speed feedback is no more present. This is possible when the converter is working at constant field. In this case with a disconnected reaction signal, it is necessary to carry out again the above mentioned optimization of the speed regulator. The P section of the speed regulator is set via the **Speed P bypass** parameter and the I section with the **Speed I bypass** parameter.

In some cases it is necessary to have different gains for the speed regulator, above the speed range. To this purpose the converters of the TPD32 series are provided with an adaptive speed regulator.

For the tuning see the following pages

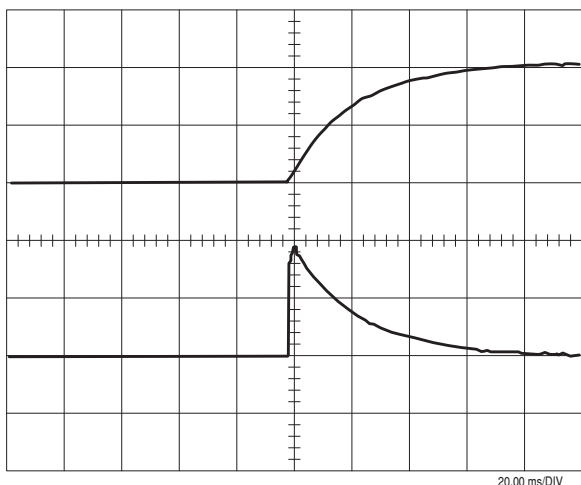

Figure 5.3.6.1: Above: Actual spd; Below: Motor current. Speed P too low.

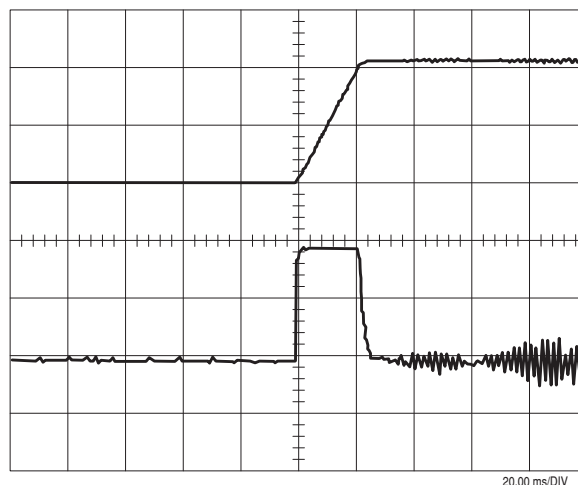

Figure 5.3.6.2: Above: Actual spd; Below: Motor current. Speed P too high.

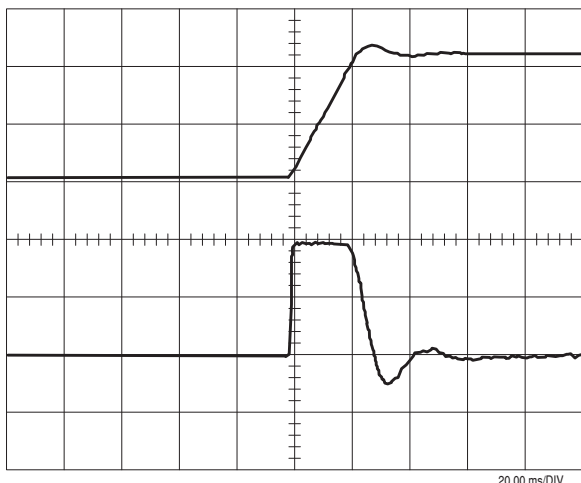

Figure 5.3.6.3: Above: Actual spd; Below: Motor current. Speed I too high.

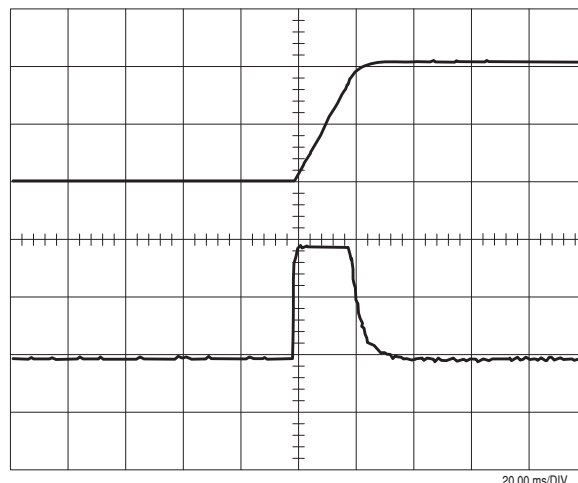

Figure 5.3.6.4: Above: Actual spd; Below: Motor current. Speed P and Speed I set correctly.

### Manual tuning of field current regulator

**Note!** In the majority of the cases the dc motors with an independent excitation operate with a direct field (**Flux reg mode** = Constant current). In this case it is not necessary to optimize the regulator of the field current and the regulator of the armature voltage.

The optimization showed below, refers to drives operating with constant power range (armature and field mixed regulation). In these cases it is necessary to configure the field converter for this particular use. See below.

**Note!** During the optimization of the regulator of the field current, the converter must not receive a Start command.

- Converter disabled (no voltage on terminal 12)
- Menu LIMITS / Flux limits: **Flux current max** = 100% equal to the rated field current of the motor.  
**Flux current min** = 0
- Set at 0.00 the **Flux I** and **Flux P** parameters in the REG PARAMETERS / ...menu .

- Measure the field current via an analog output. To this purpose the variable “Flux current” has to be parameterized on one output and the variable “Flux reference” on another (see “Input/Output programming”).
- Select the FLUX REGULATION menu.
- **Enable flux reg** = Enabled (default)
- **Flux reg mode** = Voltage control
- **Enable flux weak** = Enabled
- Set **Gen access** = Flux reference and **Gen amplitude** to 70% of the rated field motor current (this to allow the overshoot of the system).
- Increase the value of the **Flux P** parameter till the overshoot of the field current is lower than 4% (**Field curr**).
- Increase the value of **Flux I** until the overshoot is higher than 4%, then reduce it slightly lower than 4% .

**Note!** Because of the high time constant, the rate of rise of the field current is limited . The increase time with optimal scale conditions can be last several hundreds of milliseconds.

- **Gen access** = Disconnected
- **Enable flux weak** = Disabled
- Set **Flux current min** at the desired value
- Configure the analog outputs on the basis of your needs.
- Save the settings.

Figures 5.3.6.5 ... 5.3.6.7 show some examples of tuning of the Flux regulator

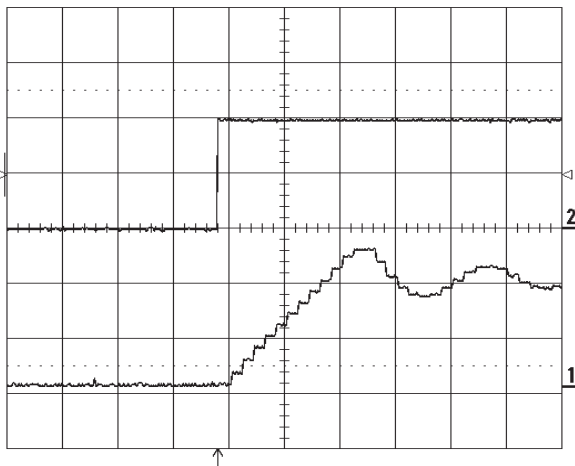

Figure 5.3.6.5: Above: Flux reference; Below: Flux current. The regulator behavior is not good. Jumps are due to field changing.

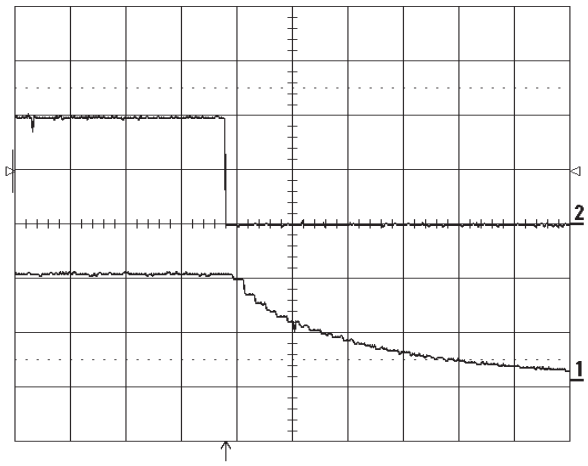

Figure 5.3.6.6: Above: Flux reference; Below: Flux current. The reduction of the field current depends on the field time constant. The reg has no influence.

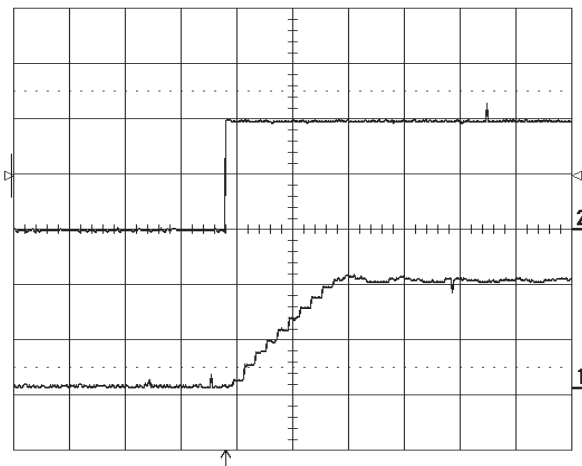

Figure 5.3.6.7: Above: Flux reference; Below: Flux current. The increment in the field current has no jump. Variation compared to Fig. 4.5.7: Increase of **Flux P** from 2 to 10%. **Flux I** = 5%.

## Voltage regulator in the field converter

**Note!** In the most of the cases the DC motors with an independent excitation operate with a direct field (**Flux reg mode=Constant current**). In this case it is not necessary to optimize the regulator of the armature voltage.

When a Voltage control occurs, the voltage regulator keeps the armature voltage at a constant level. The most difficult moment for this regulator is the beginning of the Voltage control, because due to the saturation of the motor field, the flux variation requires quicker changes of the field current.

Tune the regulator in order to have small changes of the armature voltage.

**Note!** All the other converter regulators must be set before the optimization of the voltage regulator.

- Drive disabled = no voltage on terminal 12
  
- Choose the following settings for the Test generator :
  - **Gen access** = Ramp ref
  - **Gen frequency** = 0.2 Hz
  - **Gen amplitude** = 10 %
  - **Gen offset** = according to the changing point from the armature regulation to the field one. Example: **Motor max speed** = 2000 rpm, the Voltage control starts at 1500 rpm. **Gen offset** = 75 %
  
- Measure the field current and the armature voltage on an analog output. The “Flux current” and the “Output voltage” variables must be set on two different analog outputs (see Programming “Inputs/Outputs”).
  
- Enable the drive and give the Start command (voltage on the terminals 12 and 13)
  
- Check the armature voltage. After a possible short jump, the voltage should remain constant. See figures 5.3.6.8 ... 5.3.6.10. In the REG PARAMETER /... menu, it is possible to change the P and I section with the **Voltage P** and **Voltage I** parameters.
  
- Stop and disable the drive.
- Gen access = Not connected
- Save the settings.

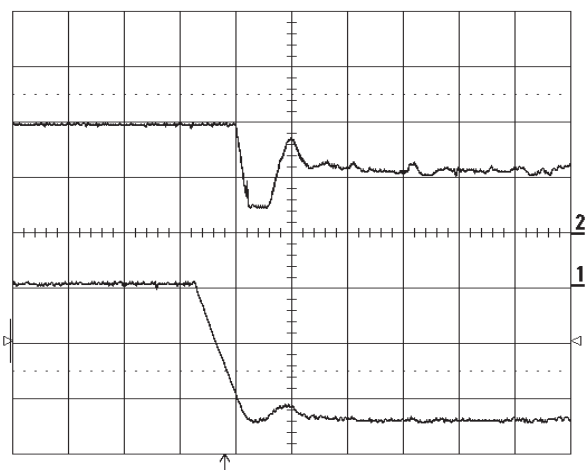

Figure 5.3.6.8: Above: Flux; Below: Output voltage.  
After a speed change the field current (Flux) has some jumps. Voltage P = 10%, Voltage I = 80%.

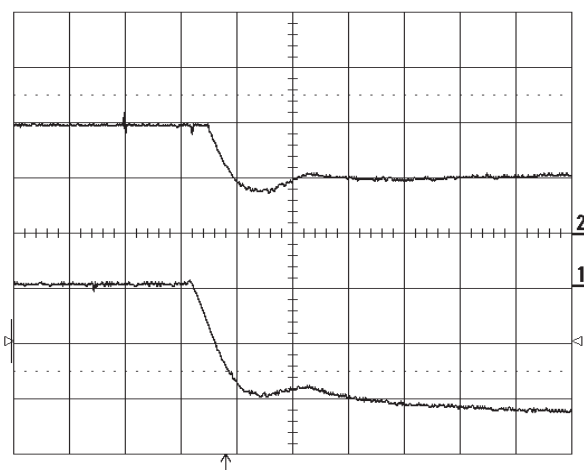

Figure 5.3.6.9: Above: Flux; Below: Output voltage.  
The gain is too low. The armature voltage increases. Voltage P = 3%, Voltage I = 5%.

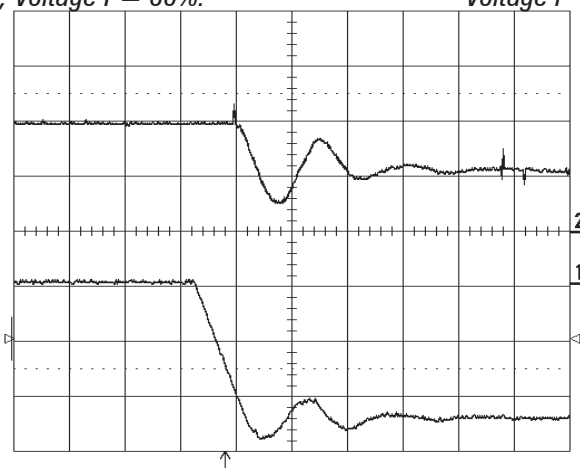

Figure 5.3.6.10: Above: Flux; Below: Output voltage.  
After a short transient, the field current and armature voltage are constant. Voltage P = 40%, Voltage I = 50%.

### 5.3.7 Others tuning

#### Flux / if curve tuning (Flux / if curve)

The function of this curve is to model the real flux of the motor. The flux model allows the control of torque current to better relate to torque. The figure below describes the relation between flux and flux current in conditions of **Flux /if curve** defined and not defined.

**Note!** The field current (previous section) and the output voltage tunings (next section) must be carried out when a Voltage control is required, whether the relevant flux curve has been defined or not.

The tunings scale is the following:

- **Field current regulator**
- **Flux/if curve tuning (Flux / if curve)**
- **Voltage regulator in the field converter**

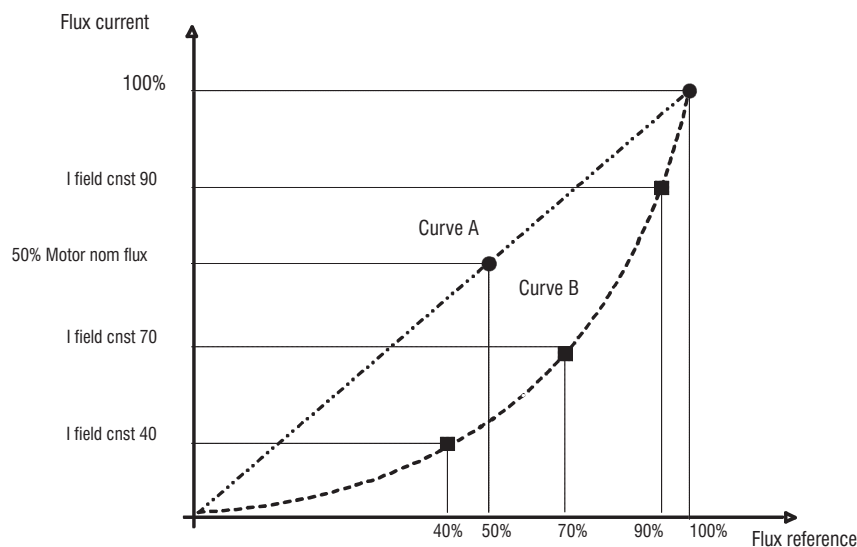

Figure 5.3.7.1: Curve conversion flux/current

Example:

A - With the default setting of the converter, there will be a linear characteristic (Curve A) of the flux current (**Flux current**) when the parameter **Flux reference** changes.

Then:

$$\mathbf{Flux\ current\ max / Flux\ reference = 100\% \quad Flux\ current / Flux\ reference = Motor\ nom\ flux}$$

$$\mathbf{Flux\ current\ max / Flux\ reference = 50\% \quad Flux\ current / Flux\ reference = 50\% \text{ of Motor nom flux}}$$

B- Carrying out the tuning of the flux curve (see below tuning procedure ) the result will be emphasized by curve B. The values of **Flux current** will follow a characteristic determined by the real flux percentage **Flux reference**, necessary to determinate the circulation of that field current for the connected system.

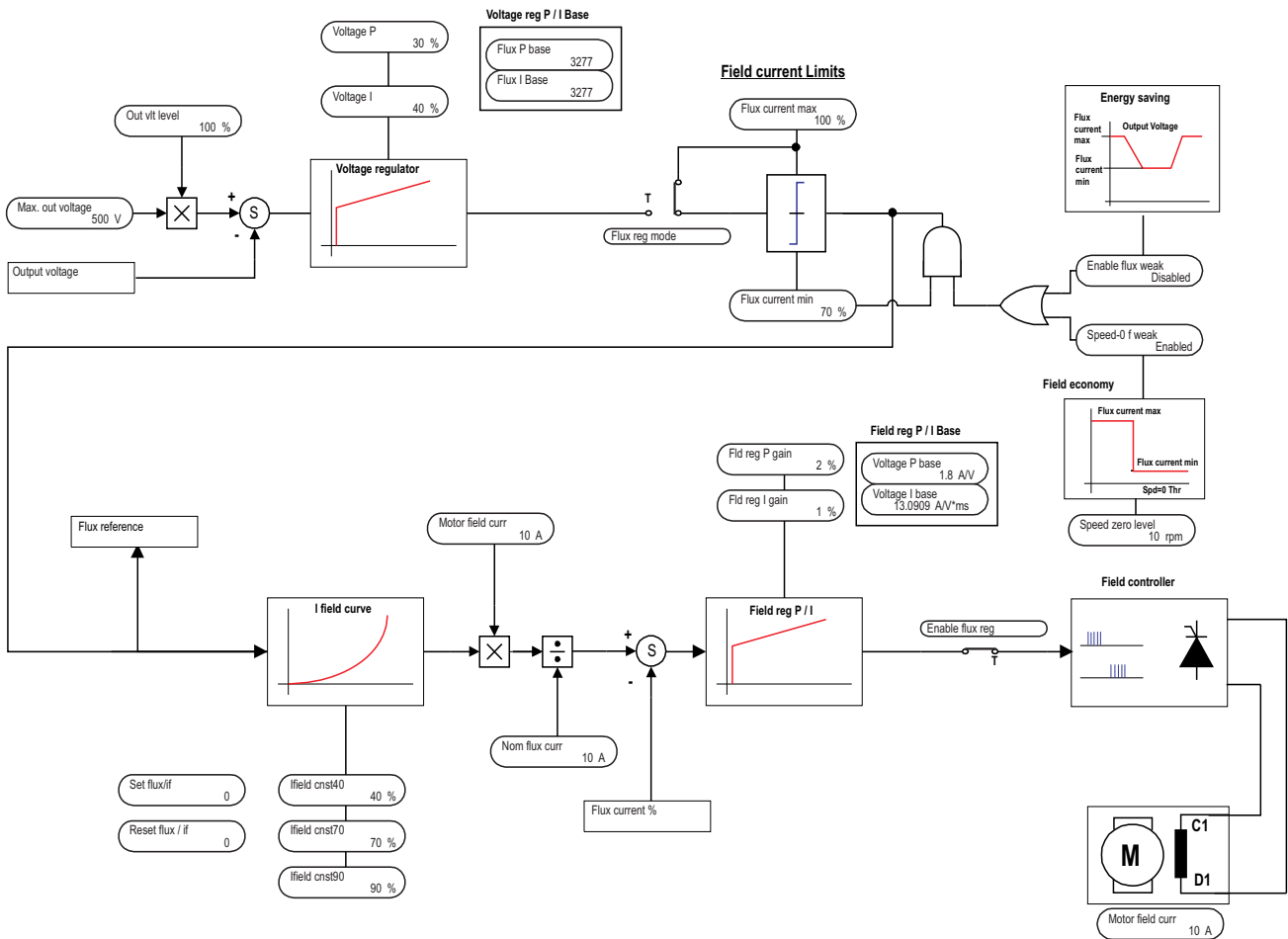

Figure 5.3.7.2: Blocks diagrams of field current regulator

### Tuning procedure:

- Reset the curve flux/current via the **Reset flux / if** command (FLUX REGULATION \ Flux / if curve menu )
- Set the Motor nom flux: **Motor nom flux** parameter (FLUX REGULATION menu)
- Set the output voltage via the **Max out voltage** parameter (CONFIGURATION menu) and the correspondent percentage (100%) in the **Out vlt level** parameter (FLUX REGULATION menu)
- Set the Flux regulator **Flux reg mode** = Constant current (FLUX REGULATION menu)
- Set the flux percentage at 100% via the **Flux current max** parameter (FLUX REGULATION menu)
- Operate the Drive speed, so that the **Armature voltage** (MONITOR\Measurements menu) corresponds to the value previously set in **Max out voltage** (CONFIGURATION menu).
- Via the **Flux current max** parameter decrease the voltage displayed in **Armature voltage**, up to obtain an output voltage equal to the 90% of **Max out voltage**.

Carry out the reading of the current in the **Flux current** parameter (FLUX REGULATION menu) and insert it in the **I field cnst 90** parameter (FLUX REGULATION\Flux if curve menu).

- Via the **Flux current max** parameters decrease the voltage displayed in **Armature voltage**, to obtain an output voltage equal to the 70% of **Max out voltage**.

Carry out the reading of the current circulating in the **Flux current** parameter (FLUX REGULATION menu) and insert it in the **I field cnst 70** parameter (FLUX REGULATION\Flux if curve menu).

- Via the **Flux current max** parameters decrease the voltage displayed in **Armature voltage**, to obtain an output voltage equal to the 40% of **Max out voltage**.

Carry out the reading of the current circulating in the **Flux current** parameter (FLUX REGULATION menu) and insert it in the **I field cnst 40** parameter (FLUX REGULATION\Flux if curve menu).



- Disable the converter
- Via the **Set flux / if** parameter (FLUX REGULATION menu) the calculation of the curve parameters will be carried out. Enter this parameter then press ENT to execute the calculation.  
The procedure requires a few seconds.
- Set the operating mode of the field control (**Constant current / Voltage control**), set the value of **Flux current max** at 100% and save the parameters.
- Changing of **Max out voltage** or **Motor nom flux** need a new curve tuning.

### Speed-up function

With loads having a high moment of inertia it is possible to check the jumps during the speed changes. They can be reduced using the function “Speed-up”. The figures 5.3.7.3 and 5.3.7.4 show the influence of this function.

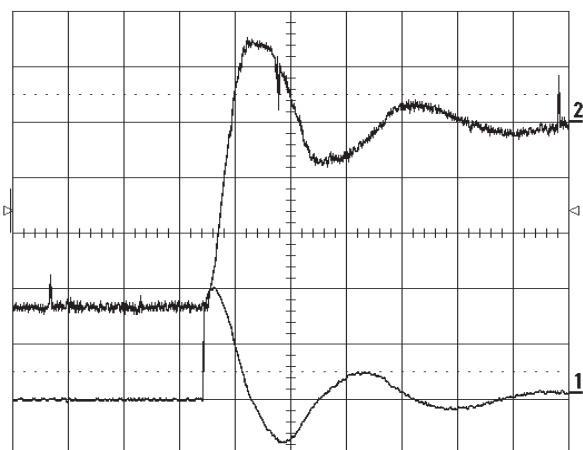

Figure 5.3.7.3: Above: Actual spd; Below: Motor current jumps with the speed changes due to a high moment of inertia. The function Speed-up is not active.

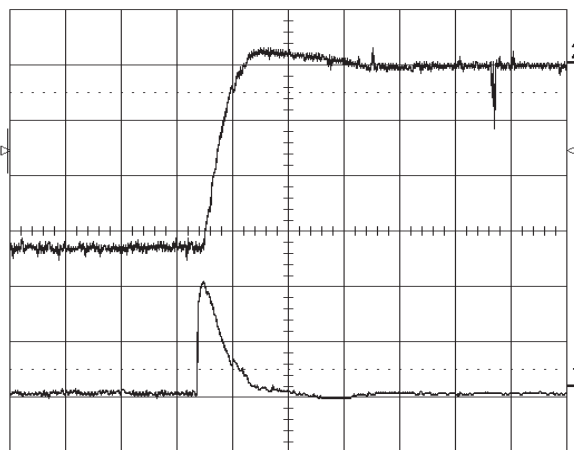

Figure 5.3.7.4: Above: Actual spd; Below: Motor current. The same drive with Speed-up function active.

#### Parameters used in the example:

|                 |       |
|-----------------|-------|
| Speed up base   | 14 ms |
| Speed up gain   | 50 %  |
| Speed up filter | 20 ms |

#### Setting of the speed zero logic

- The speed zero logic is factory set as disabled. See section 6.7.2, “Speed zero logic”, for a description of the drive behavior.
- Disable of the I-section of the speed regulator with n=0:  
I-section disabled: **Enable spd=0 I = Enabled**  
I-section enabled: **Enable spd=0 I = Disabled**

**Note!** When the motor is at a stop, it is possible to avoid the creep of the drive disabling the I section. In this case when the motor is at a stop, it can not receive any load and therefore this function is not suitable for all applications!

- Suppression of the P-gain set via **Spd=0 P gain**:
- If the reference is above **Ref 0 level**: **Enable spd=0 R = Enabled**
- If the ref.and/or the reaction are above **Ref 0 level**: **Enable spd=0 R = Disabled**

**Note!** **Enable spd=0 R** is active only when **Enable spd=0 P** is enabled.

- Choice of the proportional gain for zero speed:  
The P-gain corresponds to **Spd=0 P gain** **Enable spd=0 P** = Enabled  
The P-gain corresponds to the normal P-gain **Enable spd=0 P** = Disabled
- The P-gain at a zero speed is set via **Spd=0 P gain**, when **Enable spd=0 P** is enabled.
- The intervention threshold for the recognition of zero speed is determined with **Ref 0 level**. It is expressed in the dimension set by the factor function.

### **Adaptive of the speed regulator**

**Note!**

The adaptive of the speed regulator is factory set as disabled. It must be used only when the gain of the speed regulator has to get higher than the speed range or it has to be replaced with another unit. As for the interaction among the parameters see section 6.13.2, “Adaptive spd reg”.

- Enable of the adaptive with a blocked drive. **Enable spd adap** = Enabled. In this way the settings of **Speed P** and **Speed I** are disabled.
- Determine on the basis of which unit the gain of the speed regulator has to be changed. It normally depends on the speed (**Select adap type** = Speed).
- If the gain has to be changed on the basis of another unit, set **Select adap type** = Adap reference. This unit is connected to the device as an analog value via an analog input. For this reason the **Adap reference** variable must be assigned to an analog input (see in the following pages the configuration of the analog inputs).  
The other possibility is to insert **Adap reference** via the serial interface or a Bus. In this case the insertion via the terminal strip is not necessary.
- Entering **Adap speed 1** and **Adap speed 2** three different speed ranges are available with several gains. Value expressed as a percentage of **Speed base value** and respectively of the max value of **Adap reference**.
- With **Select adap type** = Speed: the optimization is carried out as described for the “Speed regulator”. To this purpose the following points must be taken into consideration:
  - Enter with **Gen offset** a value which is at the beginning of the range to be optimized but which at the same time is outside the range set with **Adap joint XX**.
  - Enter with **Gen amplitude** the step, so that the speed remains inside the range to be optimized.
  - The optimization is carried out separately for each range and the parameters of the regulator are set for each range with **Adap P gain XX** and **Adap I gain XX**.
  - After the optimization of the different phases look over the whole speed range.
  - By changing the value of **Adap joint XX** it is possible to reduce the instabilities present in the transients during the changes from one range to the other. Increasing the values the transients are slighter.
- With **Select adap type** = Adap reference: the optimization depends on the system and it is impossible to state here the general information needed.
- When the speed zero logic is disabled (factory setting) with a blocked drive the gains of the speed regulator are active. These are set via **Adap P gain 1** and **Adap I gain 1**. When the speed zero logic is enabled, the values set for a motor at a stop are valid.

## 6 - FUNCTION DESCRIPTION

### **Functions and parameters**

The converters of the TPD32 series feature a number of functions that can be set and assigned parameters in order to meet the requirements of the application at hand.

The device can be controlled in different ways:

- via the terminal strip
- via the keypad
- via the RS 485 serial interface
- via a bus connection (option)

The settings required are made via the **Main commands** and **Control mode** parameters in the CONFIGURATION menu.

The device is supplied with a Windows™-based user interface software for controlling the drive and setting parameters via the RS 485 serial interface.

The device is factory set for speed regulation with a cascade current regulation and is connected according to the connection diagram shown on in section 4.8, “Standard connection diagrams”. Only the entry of parameters in the START UP of the software is required for the initial commissioning of the drive. The drive is thus controlled via the terminal strip with all parameters set via the keypad.

If functions are required that are not in the standard configuration, these can be selected and their parameters set accordingly via the appropriate menu.

The TBO option card is required for expanding the standard device with programmable inputs/outputs. Up to no. 2 TBOs can be fitted, each providing 4 digital inputs, 4 digital outputs and 2 analog outputs. Three analog inputs are provided on the standard device.

The converters of the TPD32 series enable reference values for the ramp and for the speed regulator to be set in different units of measure:

- in percentages of the **Speed base value**
- in a unit of measure (dimension) that the user can define using the factor function, e.g. as speed in m/s.

According to which one is set as last the other will be updated. This means that the other reference value is overwritten with the current value.

A freely selectable password 1 prevents the operation of the converter by unauthorized persons. It is entered in the form of a five-digit number combination. Password 2 is also provided by the manufacturer. This password enables the service personnel to access the Service menu which is not accessible for the user.

**Note!** All parameter settings must be saved otherwise the last settings saved will be loaded the next time the device is switched on (Save parameters command)

## Explanation of parameter tables

In the following pages the parameters list of each menu is shown. For each table the following notes are valid:

- “No.” column            Parameter number (decimal). In order to address parameters when a serial line/bus or the APC200 card are used, the user **must** add 2000H (= decimal 8192) to the indicated value.
- “Value” field            S = value depending on the size of the device.

|                        |   |
|------------------------|---|
| <b>DRIVE STATUS</b>    | Start up parameters status  |
| <b>START UP</b>        | Basic commissioning of the drive  |
| <b>TUNING</b>          | Drive regulators tuning   |
| <b>MONITOR</b>         | Display of reference values, speed, voltage, current, frequency...  |
| <b>INPUT VARIABLES</b> | Ramp reference, speed reference, current reference  |
| <b>LIMITS</b>          | Speed limits, current limits, field current limits  |
| <b>RAMP</b>            | Acceleration, deceleration, quick stop, ramp shape  |
| <b>SPEED REGULAT</b>   | Configuration of the speed regulator, speed zero logic, speed up , droop function                         |
| <b>CURRENT REGULAT</b> | Configuration of the current regulator  |
| <b>FLUX REGULATION</b> | Functioning of the field current regulator  |
| <b>REG PARAMETERS</b>  | Parameters for speed, current, field and voltage regulation   |
| <b>CONFIGURATION</b>   | Functioning, regulation, encoder type, function factor, programmable alarms, address, password            |
| <b>I/O CONFIG</b>      | Configuration of programmable digital and analog input and output   |
| <b>ADD SPEED FUNCT</b> | Motor capture, adaptive speed regulation, speed control, speed zero                                       |
| <b>FUNCTIONS</b>       | Motopotentiometer, jog function, multi-speed, multi-ramps, overload, stop control, Taper current function |
| <b>SPEC FUNCTIONS</b>  | Test generator, saving parameters, loading factory settings, signal adaptation, PAD parameters            |
| <b>OPTIONS</b>         | Access to the optional field bus card (Option1), and the APC200 (Option2), PID function                   |
| <b>DRIVECOM</b>        | Parameter setting for the DRIVECOM profile  |
| <b>SERVICE</b>         | Menu, only accessible to service personnel of the manufacturer  |

## 6.1 ENABLES

The following hardware enables are always required irrespective of whether the device is to be controlled via the terminal strip, the keypad or the serial interface.

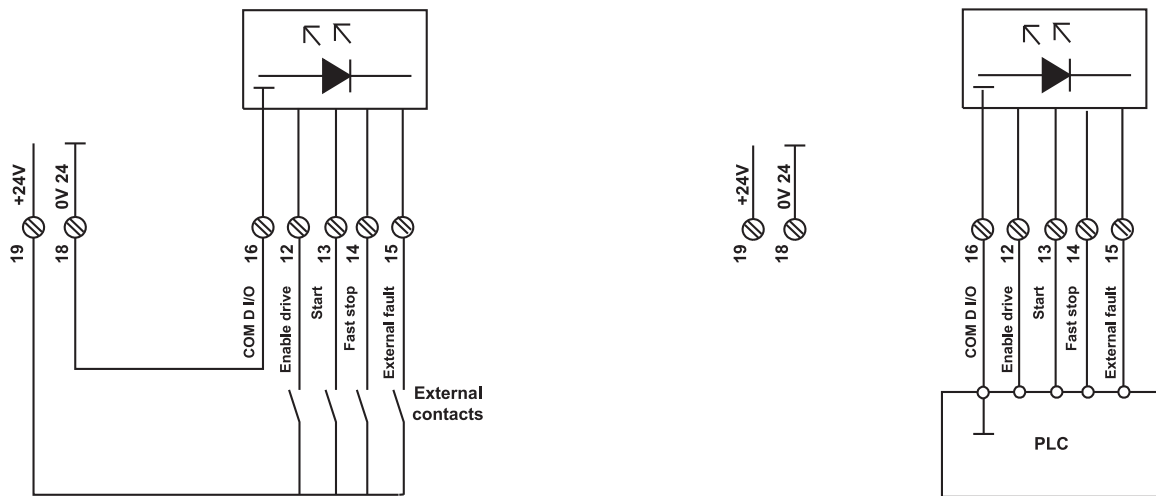

Figure 6.1.1 Enables via potential free contacts and PLC

- Figure 6.1.1 show the connection principle
- The enable signals are activated via a +15 ... 30 V voltage at the appropriate terminals. The inputs are protected against reverse polarity.
- Negative voltage, 0 V and a missing signal are interpreted as disable signals.
- The reference point for the enable signals is terminal 16.
- When using an operator keypad/serial interface (**Mains Command** = Digital), both the signals on the appropriate terminals and the corresponding commands on the keypad/serial interface are necessary. If an enable is removed via a signal on the terminals, the appropriate command must be sent via the keypad/serial interface in addition to the signal on the terminal in order to restart the drive.

There are four types of enable signals that have a different effect on the behavior of the TPD32 converter.

- **Enable drive** enables the entire converter
- **Start** enables the regulation
- **Fast stop** sets the speed reference value immediately to zero so that the motor is stopped as quickly as possible
- **External fault** incorporates external fault condition into the enable

## 6.1.1 Enable drive

|                     |       |              |
|---------------------|-------|--------------|
| <b>DRIVE STATUS</b> |       |              |
| <b>START UP</b>     |       |              |
| <b>TUNING</b>       |       |              |
| <b>MONITOR</b>      | [314] | Enable drive |

| Parameter           | No. | Value |     |                  |                  | Standard Configuration             |
|---------------------|-----|-------|-----|------------------|------------------|------------------------------------|
|                     |     | min   | max | Factory American | Factory European |                                    |
| <b>Enable drive</b> | 314 | 0     | 1   | Disabled         | Disabled         | Terminal 12<br>+15 ... 30 V<br>0 V |
| Enabled<br>Disabled |     |       |     |                  |                  |                                    |

The **Enable drive** command activates the TPD32 Drive.

An auxiliary contact on the AC Input contactor may be wired in the Drive enable (terminal 12).

When the **Enable drive**=disable and terminal 12 = 0V, no other control commands (e.g. **Jog +**, **Jog -** or **Start**) are accepted.

Removal of the **Enable drive** command (**Enable drive**=disable) while the drive is running causes the motor coasting to stop. Neither electrical braking nor controlled stopping of the motor within a prescribed time during the run down are possible. The actuation of the Drive is disabled.

When operated via the keypad the **Enable drive** command is provided in the DRIVE STATUS, START UP, TUNING and MONITOR menu.

Using **Enable drive** command from keypad (**mains command**=Digital), active voltage level is also required on terminal 12.

Using **Enable drive** command from terminal 12 set "**Main command**=terminals".

**Enable drive** in the menu is read only parameter.

## 6.1.2 Start / Stop

|                     |                  |
|---------------------|------------------|
| <b>DRIVE STATUS</b> |                  |
|                     |                  |
| <b>START UP</b>     |                  |
|                     |                  |
| <b>TUNING</b>       |                  |
|                     |                  |
| <b>MONITOR</b>      |                  |
|                     | [315] Start/Stop |

| Parameter description              | No. | Value |     |                  |                  | Standard Configuration             |
|------------------------------------|-----|-------|-----|------------------|------------------|------------------------------------|
|                                    |     | min   | max | Factory American | Factory European |                                    |
| <b>Start/Stop</b><br>Start<br>Stop | 315 | 0     | 1   | Stop (0)         | Stop (0)         | Terminal 13<br>+15 ... 30 V<br>0 V |

When **Main commands** is set to **digital**, **Start/Stop** parameter allows the motor running and the STOP button on the keypad stop the motor.

When **Main commands** is set to **terminals**, **Start/stop** will be a read only parameter.

**Note!** The following signals are required for operating the drive in addition to the **Start** command:

**Enable drive**

**Fast stop**

**External fault**

The behavior of the drive after the **Start** command is given or removed depends on the parameter setting at hand:

- When using the ramp (**Enable ramp** = Enabled and **Enable spd reg** = Enabled) the drive accelerates to the required speed according to the ramp specified. If the Start command is removed, the drive runs down to zero according to the ramp defined. If the Start command is selected once more during the deceleration time, the drive accelerates once more to the required speed.
- If the **Speed ref 1** value reaches the input of the speed regulator directly without a ramp (**Enable ramp** = Disabled and **Enable spd reg** = Enabled), the drive accelerates to the required speed in the shortest possible time once the Start command has been given. When the Start command is removed, the **Speed ref 1** value is set to zero immediately.  
The command has not effect on **Speed ref 2**.
- When using torque regulation (**Enable spd reg** = Disabled) the **Start** command enables the torque reference value (**T current ref 1**) or disables it after the **Start** command is removed.

The Start command has no effect on the correction value **Speed ref 2** (with speed regulation) or **Torque ref 2** (with torque regulation).

The **Start** command is not required for Jog function mode.

If the **Start** command and **Jog +** or **Jog -** are given at the same time, the **Start** command is given priority.

If the **Start** command is given during Jog operation, the Jog operation is aborted.

The Start parameter status is shown in the DRIVE STATUS and MONITOR menu.

### 6.1.3 Fast stop

| Parameter description                         | No. | Value |     |                  |                  | Standard Configuration             |
|---|-----|-------|-----|------------------|------------------|------------------------------------|
|   |     | min   | max | Factory American | Factory European |                                    |
| <b>Fast/Stop</b><br>Fast Stop<br>No Fast Stop | 316 | 0     | 1   | No Fast Stop     | No Fast Stop     | Terminal 14<br>+15 ... 30 V<br>0 V |

Terminal 14:                      +15 ... 30V = No Fast stop                      0V = Fast stop

**Note!**                      **The function cannot be actuated via the keypad!**

Application: **Fast stop** is actuated in emergencies and hazardous situations, in order to stop the drive in the shortest possible time. This method of stopping has the advantage over disconnection in that with a four quadrant drive (TPD32... 4B) energy can be recovered in the AC input and the motor can be brought to a halt in a shorter time than when it coasts down.

The **Fast stop** command is always required for operation of the converter. A removal of the command when the drive is running initiates braking with the ramp specified by the parameters **Qstp delta speed** and **Qstp delta time**.

When the drive is brought to a halt, it is still enabled and has torque. The **Start** command or **Enable drive** command must be removed for it to be disconnected.

The drive behavior after the Fast stop command has been given depends on the type of operating mode selected:

- Operation via the terminal strip (**Main commands** = Terminals):  
The drive executes braking until there is no voltage on terminal 14. When voltage is restored, the drive automatically accelerates to the required reference value (precondition: the other enable commands are still active).
- Operation via serial line with commands given via terminals too (**Main commands** = Digital):  
The drive executes braking until it has come to a halt. When voltage is restored on terminal 14, there is no automatic start. This requires the entry of the Start command.
- If the **Fast stop** command is actuated via the serial interface while there is a voltage present on terminal 14, the fast stop is executed until the drive is at a halt. The **Start** command must be entered for the drive to be restarted.



### 6.1.4 Quick Stop

| Parameter description       | No. | Value |     |                  |                  | Standard Configuration |
|-----------------------------|-----|-------|-----|------------------|------------------|------------------------|
|                             |     | min   | max | Factory American | Factory European |                        |
| <b>Quick stop</b>           | 343 | 0     | 1   | No Quick stop    | No Quick stop    |                        |
| Quick stop<br>No Quick stop |     |       |     |                  |                  |                        |

**Note!** This function cannot be executed via the terminal strip or the keypad but can only be actuated via the serial interface or a bus connection!

**Application:** **Quick stop** is actuated in emergencies or hazardous situations in order to bring the drive to a halt in the shortest possible time. This method of stopping has the advantage over disconnection in that with a tetraquadrant drive (TPD32... 4B) energy can be recovered in the main and the motor can be brought to a halt in a shorter time than when it coasts down.

- If the **Quick stop** command is given when the drive is running, this initiates braking with the ramp specified by the **Qstp delta speed** and **Qstp delta time** parameters.
- When the drive is at a halt, it is disabled and thus has no torque. The **Start** command must be given again for the drive to be started.

### 6.1.5 External fault

| Parameter description               | No. | Value |     |                  |                  | Standard Configuration             |
|-------------------------------------|-----|-------|-----|------------------|------------------|------------------------------------|
|                                     |     | min   | max | Factory American | Factory European |                                    |
| <b>External fault</b>               |     | -     | -   | -                | -                | Terminal 15<br>+15 ... 30 V<br>0 V |
| External fault<br>No External fault |     |       |     |                  |                  |                                    |

The **External fault** command enables an external signal to be incorporated in the failure alarms of the converter.

**Application example** The converter is being used for closed-loop control of a single drive without contactors. A temperature-dependent contact, which opens under excessive temperature, is located within the motor. Connect this contact between 24 V and terminal 15. When the contact opens (= overtemperature) the converter will be disabled.

- During operation a signal is always required on terminal 15, irrespective of whether the commands are transmitted via the terminal strip or not.
- In the event of an external fault, the drive will behave according to the configuration set in the "Programmable Alarms, 6.11.7."

## 6.2 BASIC START UP MENUS

The following DRIVE STATUS, START UP and TUNING allow a basic commissioning of the drive.

**Note !** The parameters in these menus are available in other menus.  
See Start up procedure on chapter 5.3 for commissioning information.

### DRIVE STATUS

Menu displayed at power up.

Status parameters of the drive are available and **Ramp ref 1** parameter for basic speed reference with ramp time.

### START UP

In this menu the start up sequencing is available.

#### First basic setting

|                         |  |
|-------------------------|--|
| <b>Speed base value</b> | <b>Speed base value</b> is defined by the unit in the factor function specified. It is the reference value for all the speed reference values (reference values, adaptive speed regulation) given as a percentage, and corresponds to 100% of the speed. Changing this parameter is only possible when the drive is disabled ( <b>Enable drive</b> =Disable). The speed base value does not define the maximum possible speed, which in some cases can be formed from the addition of several reference values. This is defined with Speed max amount. |
| <b>Nom flux curr</b>    | Drive field current value.   |
| <b>Speed-0 f weak</b>   | Enables the field economy at zero speed.   |
| <b>Acc / Dec ...</b>    | Acceleration and deceleration ramp time setting on the speed reference.(see chapter 6.6.1 for more details).   |

#### Motor data

Motor plate data:

|                        |  |
|------------------------|--|
| <b>Motor nom flux</b>  | Motor field current in Amps.   |
| <b>Flux reg mode</b>   | Field regulator mode.  |
| <b>Full load curr</b>  | Nominal motor current in Amps.   |
| <b>Motor max speed</b> | Maximum motor speed value  |
| <b>Max out voltage</b> | Maximum armature voltage value   |
| <b>Flux weak speed</b> | <b>Motor max speed</b> percentage where the flux weakening range starts. (Crossover point) |

## Limits

Speed limits and current limits drive setting:

|                         |  |
|-------------------------|--|
| <b>T current lim</b>    | Current limit setting (see chapter 6.5.2 for more details).  |
| <b>Flux current max</b> | Maximum field current value as percentage of <b>Motor fld curr</b> .                                       |
| <b>Flux current min</b> | Minimum field current value as percentage of <b>Motor fld curr</b> . (See chapter 6.5.3 for more details). |
| <b>Speed min amount</b> | Minimum speed reference limit. (see chapter 6.5.1 for more details).                                       |
| <b>Speed max amount</b> | Maximum speed reference limit. (see chapter 6.5.1 for more details).                                       |

## Speed feedback

Speed feedback setting (see chapter 6.11.5 for more details) :

|                         |   |
|-------------------------|---|
| <b>Speed fbk sel</b>    | Speed feedback selection  |
| <b>Tacho scale</b>      | Tach generator feedback scaling ( <b>Speed fbk sel</b> must be set to <b>Tacho</b> ).   |
| <b>Speed offset</b>     | Speed feedback offset   |
| <b>Encoder 2 pulses</b> | Number of pulses per revolution of the digital encoder to the XE2 connector.  |
| <b>Enable fbk contr</b> | Speed feedback loss control. The <b>Motor max speed</b> , <b>Max out voltage</b> , <b>Flux weak speed</b> parameters must be set correctly according to the motor used. |
| <b>Refresh enc 2</b>    | Enable the monitoring of the encoder 2 (XE2 connector) connection status (A , B, Anot, Bnot channels). <b>Enable fbk contr</b> must be enabled.                         |

## Alarms

Overvoltage and Overcurrent threshold setting (see chapter 6.11.7 for more details) :

|                        |                                    |
|------------------------|------------------------------------|
| <b>Undervolt thr</b>   | AC input alarm threshold value     |
| <b>Overcurrent thr</b> | Overcurrent alarm threshold value. |

## Overload control

Current overload setting (see chapter 6.14.6 for more details) :

|                         |  |
|-------------------------|--|
| <b>Enable overload</b>  | Current overload control enabling.   |
| <b>Overload mode</b>    | Overload current mode selection (Curr limited, Curr not limited, I2t Motor, I2t Drive, I2t motor & I2t drive). |
| <b>Overload current</b> | Drive output current permissible during the overload time.   |
| <b>Base current</b>     | Drive output current permissible during the pause time.  |
| <b>Overload time</b>    | Maximum time in which the <b>Overload current</b> is permissible.  |
| <b>Pause time</b>       | Minimum time between overload cycles.  |

## **Analog inputs**

For programmable analog inputs see chapter 6.12.2 for more details.

## **Self tuning of current regulator**

See chapter 5.3.5.1.

**R&L Search**                      Command for current regulator self tuning execution

- Enable the drive (**Enable Drive** parameter= Enabled)
- Start the drive (**Start/Stop** parameter = Start).

## **Self tuning of speed regulator**

(see chapter 5.3.5.2 for more details):

|                         |  |
|-------------------------|--|
| <b>Fwd-Rev spd tune</b> | Direction of motor shaft rotation for the speed self tune test (Forward or Reverse; Forward is clock-wise as seen from shaft drive end).                                 |
| <b>Test T curr lim</b>  | Torque current limit applied during Speed self tune test.  |
| <b>Start</b>            | Speed regulator self tuning start command.   |
| <b>Inertia</b>          | Total Inertia value at the motor shaft in Kg*m <sup>2</sup> ( <b>1 Kg*m<sup>2</sup> = 23.76 lb*ft<sup>2</sup></b> ).   |
| <b>Inertia Nw</b>       | New total Inertia value at the motor shaft in Kg*m <sup>2</sup> identified during the speed self tune procedure. ( <b>1 Kg*m<sup>2</sup> = 23.76 lb*ft<sup>2</sup></b> ) |
| <b>Friction</b>         | Friction value (or Loss compensation) in N*m ( <b>1 N*m = 0.738 lb*ft</b> ).   |
| <b>Friction Nw</b>      | New Friction value (or Loss compensation) in N*m identified during the speed self tune procedure. ( <b>1 N*m = 0.738 lb*ft</b> )   |
| <b>Speed P</b>          | Proportional coefficient of the speed regulator in percentage  |
| <b>Speed P Nw</b>       | New value of Proportional coefficient of the speed regulator in percentage computed during the speed self tune procedure.  |
| <b>Speed I</b>          | Integral coefficient of the speed regulator in percentage  |
| <b>Speed I Nw</b>       | New value of Integral coefficient of the speed regulator in percentage computed during the speed self tune procedure.  |
| <b>Take val</b>         | Acquire the parameters after the self tune procedure (overwrite current values).   |

**Note !**                      This is not a permanent save. Go to “Save parameters” command.

## ***Final operation***

(See chapter 6.11.1 for more parameters detail).

|                        |  |
|------------------------|--|
| <b>Main commands</b>   | This command specifies from where the <b>Enable drive</b> and <b>Start</b> command has to be actuated. |
| <b>Control mode</b>    | Defines whether the digital channel is the keypad/RS485 or Fieldbus card.                              |
| <b>Save parameters</b> | Saving of user parameters value setting  |

## ***TUNING***

This menu allows a fine manual tuning of the drive regulators.

### ***Current self tuning***

Current regulator self tuning procedure via **R&L Search** (as indicate in START UP menu).

### ***Speed self tune***

Speed regulator self tune procedure (as indicate in START UP\ Speed self tune menu).

### ***Manual tuning of speed regulator, field regulator and voltage regulator***

Manual tuning of the drive regulators (see chapter 5.3.6 for other details):

|                        |   |
|------------------------|---|
| <b>Speed P</b>         | Proportional coefficient of the speed regulator in percentage               |
| <b>Speed I</b>         | Integral coefficient of the speed regulator in percentage.                  |
| <b>Prop filter</b>     | Time constant filter to the proportional coefficient of the speed regulator |
| <b>Flux P</b>          | Proportional coefficient of the field regulator in percentage.              |
| <b>Flux I</b>          | Integral coefficient of the field regulator in percentage                   |
| <b>Voltage P</b>       | Proportional coefficient of the voltage regulator in percentage.            |
| <b>Voltage I</b>       | Integral coefficient of the voltage regulator in percentage                 |
| <b>Save parameters</b> | Saving of user parameters value setting                                     |

## 6.3 MONITOR

| MONITOR             |                      |
|---------------------|----------------------|
| [314]               | Enable drive         |
| [315]               | Start/Stop           |
| <b>Measurements</b> |                      |
| <b>Speed</b>        |                      |
| <b>Speed in DRC</b> |                      |
| [109]               | Ramp ref (d) [FF]    |
| [112]               | Ramp output (d) [FF] |
| [115]               | Speed ref (d) [FF]   |
| [119]               | Actual spd (d) [FF]  |
| [925]               | F act spd (d) [FF]   |
| [923]               | Act spd filter [s]   |
| <b>Speed in rpm</b> |                      |
| [110]               | Ramp ref (rpm)       |
| [113]               | Ramp outp (rpm)      |
| [118]               | Speed ref (rpm)      |
| [122]               | Actual spd (rpm)     |
| [427]               | Enc 1 speed (rpm)    |
| [420]               | Enc 2 speed (rpm)    |
| [924]               | F act spd (rpm)      |
| [923]               | Act spd filter [s]   |
| <b>Speed in %</b>   |                      |
| [111]               | Ramp ref (%)         |
| [114]               | Ramp output (%)      |
| [117]               | Speed ref (%)        |
| [121]               | Actual spd (%)       |
| [466]               | Mains voltage [V]    |
| [588]               | Mains frequency [Hz] |
| [1052]              | Output power [Kw]    |
| [233]               | Output voltage [V]   |
| [199]               | Motor current [%]    |
| [928]               | F T curr (%)         |
| [926]               | T curr filter [s]    |
| [41]                | T current ref [%]    |
| [500]               | Flux reference [%]   |
| [234]               | Flux current %       |
| [351]               | Flux current (A)     |
| <b>I/O</b>          |                      |
|                     | Digital I/Q          |
| [582]               | Virtual dig inp      |
| [583]               | Virtual dig out      |

The MONITOR menu shows all current reference and actual values and also the situation of the digital inputs/ outputs. The values related to the speed are given in rpm (revolutions per minute), as a percentage (related to the **Speed base value**) and in the dimension specified by the factor function.

| Parameter description                              | No.  | Value  |         |                  |                  | Standard Configuration             |
|--|------|--------|---------|------------------|------------------|------------------------------------|
|  |      | min    | max     | Factory American | Factory European |                                    |
| <b>Enable drive</b><br>Enabled (1)<br>Disabled (0) | 314  | 0      | 1       | Disabled         | Disabled         | Terminal 12<br>+15 ... 30 V<br>0 V |
| <b>Start/Stop</b><br>Start (1)<br>Stop (0)         | 315  | 0      | 1       | Stop (0)         | Stop (0)         | Terminal 13<br>+15 ... 30 V<br>0 V |
| <b>Ramp ref (d) [FF]</b>                           | 109  | -32768 | +32767  | -                | -                | -                                  |
| <b>Ramp ref (rpm)</b>                              | 110  | -32768 | +32767  | -                | -                | *                                  |
| <b>Ramp ref (%)</b>                                | 111  | -200.0 | +200.0  | -                | -                | -                                  |
| <b>Ramp output (d) [FF]</b>                        | 112  | -32768 | +32767  | -                | -                | -                                  |
| <b>Ramp outp (rpm)</b>                             | 113  | -32768 | +32767  | -                | -                | *                                  |
| <b>Ramp output (%)</b>                             | 114  | -200.0 | +200.0  | -                | -                | -                                  |
| <b>Speed ref (d) [FF]</b>                          | 115  | -32768 | +32767  | -                | -                | -                                  |
| <b>Speed ref (rpm)</b>                             | 118  | -32768 | +32767  | -                | -                | *                                  |
| <b>Speed ref (%)</b>                               | 117  | -200.0 | +200.0  | -                | -                | -                                  |
| <b>Actual spd (d) [FF]</b>                         | 119  | -32768 | +32767  | -                | -                | -                                  |
| <b>Actual spd (rpm)</b>                            | 122  | -8192  | +8192   | -                | -                | An Output 1 *                      |
| <b>Actual spd (%)</b>                              | 121  | -200.0 | +200.0  | -                | -                | -                                  |
| <b>F act spd (rpm)</b>                             | 924  | -32768 | +32767  | -                | -                | *                                  |
| <b>Act spd filter [s]</b>                          | 923  | 0.001  | 1.000   | 0.100            | 0.100            | -                                  |
| <b>Enc 1 speed (rpm)</b>                           | 427  | -8192  | +8192   | -                | -                | -                                  |
| <b>Enc 2 speed (rpm)</b>                           | 420  | -8192  | +8192   | -                | -                | -                                  |
| <b>Mains voltage [V]</b>                           | 466  | 0      | 999     | -                | -                | *                                  |
| <b>Mains frequency [Hz]</b>                        | 588  | 0.0    | 70.0    | -                | -                | -                                  |
| <b>Output power [Kw]</b>                           | 1052 | 0.01   | 9999.99 | -                | -                | -                                  |
| <b>Output voltage [V]</b>                          | 233  | 0      | 999     | -                | -                | *                                  |
| <b>Motor current [%]</b>                           | 199  | -250   | 250     | -                | -                | *                                  |
| <b>F T curr (%)</b>                                | 928  | -500   | +500    | -                | -                | *                                  |
| <b>T curr filter [s]</b>                           | 926  | 0.001  | 0.250   | 0.100            | 0.100            | -                                  |
| <b>T current ref [%]</b>                           | 41   | -200   | +200    | -                | -                | *                                  |
| <b>Flux reference [%]</b>                          | 500  | 0.0    | 100.0   | -                | -                | *                                  |
| <b>Flux current [%]</b>                            | 234  | 0.0    | 100.0   | -                | -                | *                                  |
| <b>Flux current (A)</b>                            | 351  | 0.1    | 99.9    | S                | S                | -                                  |
| <b>Digital I/Q</b>                                 |      |        |         | -                | -                | -                                  |
| <b>Dig input term 1</b>                            | 565  | 0      | 1       | -                | -                | -                                  |
| <b>Dig input term 2</b>                            | 566  | 0      | 1       | -                | -                | -                                  |
| <b>Dig input term 3</b>                            | 567  | 0      | 1       | -                | -                | -                                  |
| <b>Dig input term 4</b>                            | 568  | 0      | 1       | -                | -                | -                                  |
| <b>Dig input term 5</b>                            | 569  | 0      | 1       | -                | -                | -                                  |
| <b>Dig input term 6</b>                            | 570  | 0      | 1       | -                | -                | -                                  |
| <b>Dig input term 7</b>                            | 571  | 0      | 1       | -                | -                | -                                  |
| <b>Dig input term 8</b>                            | 572  | 0      | 1       | -                | -                | -                                  |
| <b>Dig input term 9</b>                            | 573  | 0      | 1       | -                | -                | -                                  |
| <b>Dig input term 10</b>                           | 574  | 0      | 1       | -                | -                | -                                  |
| <b>Dig input term 11</b>                           | 575  | 0      | 1       | -                | -                | -                                  |
| <b>Dig input term 12</b>                           | 576  | 0      | 1       | -                | -                | -                                  |
| <b>Dig input term 15</b>                           | 579  | 0      | 1       | -                | -                | -                                  |
| <b>Dig input term 16</b>                           | 580  | 0      | 1       | -                | -                | -                                  |
| <b>Dig output term</b>                             | 581  | 0      | 65535   | -                | -                | -                                  |
| <b>Virtual dig inp</b>                             | 582  | 0      | 65535   | -                | -                | -                                  |
| <b>Virtual dig out</b>                             | 583  | 0      | 65535   | -                | -                | -                                  |

\* This function can be assigned to a programmable analog output.

|                           |  |
|---------------------------|--|
| <b>Enable drive</b>       | When the converter is controlled via the keypad, it is activated via the <b>Enable drive</b> parameter. A voltage is also required on terminal 12. The <b>Start</b> command is required for starting the drive.<br>Enabled                      Enable drive<br>Disable                      Drive disabled  |
| <b>Start/Stop</b>         | Using the keypad as Start/Stop control, if Enter key is pushed, the motor run at the speed set.  |
| <b>Ramp red (d)</b>       | Total reference value for the ramp in units specified by the factor function.  |
| <b>Ramp ref (rpm)</b>     | Total reference value for the ramp in rpm.   |
| <b>Ramp ref (%)</b>       | Total reference value for the ramp as a percentage of the <b>Speed base value</b> .  |
| <b>Ramp output (d)</b>    | Ramp output in units specified by the factor function.   |
| <b>Ramp outp (rpm)</b>    | Ramp output in rpm.  |
| <b>Ramp output (%)</b>    | Ramp output as a percentage of the <b>Speed base value</b> .   |
| <b>Speed ref (d)</b>      | Total speed reference value in units specified by the factor function.   |
| <b>Speed ref (rpm)</b>    | Total speed reference value in rpm.  |
| <b>Speed ref (%)</b>      | Total speed reference value as a percentage of the <b>Speed base value</b> .   |
| <b>Actual spd (d)</b>     | Actual speed in units specified by the factor function.  |
| <b>Actual spd (rpm)</b>   | Actual speed in rpm (revolutions per minute).  |
| <b>Actual spd (%)</b>     | Actual speed as a percentage of the <b>Speed base value</b> .  |
| <b>F act spd (d)</b>      | Filtered value of <b>Actual speed</b> in units specified by the factor function.   |
| <b>F act spd (rpm)</b>    | Filtered value of <b>Actual speed</b> in rpm.  |
| <b>Act spd filter</b>     | 1 <sup>st</sup> order low pass filter time constant on <b>Actual speed</b> .   |
| <b>Enc 1 speed (rpm)</b>  | Actual speed measured by the encoder 1. The parameter is accessible only if the <b>Speed fbk sel</b> = encoder 2 and a digital encoder is used as encoder 1 (interfacing with the drive by means of the DEII card).  |
| <b>Enc. 2 speed (rpm)</b> | Actual speed measured by the encoder 2. The parameter is accessible only if <b>Speed fbk sel</b> = encoder 2   |
| <b>Mains voltage</b>      | Mains voltage in V.  |
| <b>Mains frequency</b>    | AC input frequency in Hz.  |
| <b>Output power</b>       | Output power value in Kw.  |
| <b>Output voltage</b>     | Armature Voltage $U_{dA}$ in $V_{AV}$  |
| <b>Motor current</b>      | Armature current in % of <b>Full load curr</b> .   |
| <b>F T curr (%)</b>       | Filtered value of <b>Torque current</b> in percentage.   |
| <b>T curr filter</b>      | 1 <sup>st</sup> order low pass filter time constant on <b>Torque current</b> .   |
| <b>T current ref</b>      | Total current reference value as a percentage of the <b>Full load current</b> .  |
| <b>Flux reference</b>     | Field current (reference) as a percentage of <b>Motor nom flux</b> .   |
| <b>Flux curr (%)</b>      | Actual field current value as percentage of <b>Motor nom flux</b> .  |
| <b>Flux curr (A)</b>      | Actual field current value in amps.  |
| <b>Digital I/O</b>        | Status of the digital input and output of the base converter and the card TBO.<br>Display:            I    1 2 3 4 5 6 7 8 E S F<br>Q    1 2 3 4 5 6 7 8<br><br>An I/O is displayed only if a voltage is present on the corresponding terminal. E.g., if the inputs 4 and 6 are displayed, that means that the digital inputs 4 and 6 on the TBO card are to High level.<br>E= Enable drive (terminal 12)<br>S= Start (terminal 13)<br>F= Fast stop (terminal 14)<br><br>When a serial line or a Bus is used, the status of the digital I/O can be read by means of the <b>Dig input term</b> and <b>Dig output term</b> parameters. |



## Dig input term

Status of the digital inputs on the device and TBO option card to be read by serial line or field bus. The information is contained in a word, where each bit is 1 if voltage is present on the corresponding input terminal.

| Bit n. | output                                 | Bit n. | Input                             |
|--------|--|--------|-----------------------------------|
| 0      | TBO "A", Term. 31<br>(Digital input 1) | 8      | TPD32, Term. 12<br>(Enable drive) |
| 1      | TBO "A", Term. 32<br>(Digital input 2) | 9      | TPD32, Term. 13<br>(Start)        |
| 2      | TBO "A", Term. 33<br>(Digital input 3) | 10     | TPD32, Term. 14<br>(Fast stop)    |
| 3      | TBO "A", Term. 34<br>(Digital input 4) |        |                                   |
| 4      | TBO "B", Term. 11<br>(Digital input 5) |        |                                   |
| 5      | TBO "B", Term. 12<br>(Digital input 6) |        |                                   |
| 6      | TBO "B", Term. 13<br>(Digital input 7) |        |                                   |
| 7      | TBO "B", Term. 14<br>(Digital input 8) |        |                                   |

### Dig input term 1\*

Status of the digital input 1 (terminal 21, integrated TBO "A")

### Dig input term 2\*

Status of the digital input 2 (terminal 22, integrated TBO "A")

### Dig input term 3\*

Status of the digital input 3 (terminal 23, integrated TBO "A")

### Dig input term 4\*

Status of the digital input 4 (terminal 24, integrated TBO "A")

### Dig input term 5\*

Status of the digital input 5 (terminal 11, option TBO, TBO "B")

### Dig input term 6\*

Status of the digital input 6 (terminal 12, option TBO, TBO "B")

### Dig input term 7\*

Status of the digital input 7 (terminal 13, option TBO, TBO "B")

### Dig input term 8\*

Status of the digital input 8 (terminal 14, option TBO, TBO "B")

### Dig input term 9\*

Status of the digital input on terminal 12 (Enable drive)

### Dig input term 10\*

Status of the digital input on terminal 13 (Start)

### Dig input term 11\*

Status of the digital input on terminal 14 (Fast stop)

### Dig input term 12\*

Not used

### Dig input term 13\*

Not used

### Dig input term 14\*

Not used

### Dig input term 15\*

Not used

### Dig input term 16\*

Not used

## Dig output term

Status of the digital outputs on the device and TBO option card to be read by serial line or field bus. The information is contained in a word, where each bit is 1 if voltage is present on the corresponding terminal.

| Bit n. | output                                  | Bit n. | Input                                  |
|--------|---|--------|--|
| 0      | TBO "A", Term. 26<br>(Digital output 1) | 4      | TBO "B", Term. 6<br>(Digital output 5) |
| 1      | TBO "A", Term. 27<br>(Digital output 2) | 5      | TBO "B", Term. 7<br>(Digital output 6) |
| 2      | TBO "A", Term. 28<br>(Digital output 3) | 6      | TBO "B", Term. 8<br>(Digital output 7) |
| 3      | TBO "A", Term. 29<br>(Digital output 4) | 7      | TBO "B", Term. 9<br>(Digital output 8) |

## Virtual dig inp

Status of the virtual digital inputs\*\*

## Virtual dig out

Status of the virtual digital outputs\*\*

\* Available only via RS485 interface line or via a Field Bus.

\*\* The virtual inputs and outputs are used only in connection with a bus interface, in order to allow a faster communication. For further details see the interface bus documentation.

## 6.4 INPUT VARIABLES

The converters of the TPD32 series enable reference values for the ramp and regulator to be specified in different dimensions:

- as a percentage of the **Speed base value**
- in a dimension that the user can define himself with the factor-function, i.e. as a speed m/s. The default factory setting is rpm.

The value processes inside the device is the same irrespective of how it was defined. This means that the other reference is overwritten with the new value.

### Example:

A motor has a maximum speed of 1500 rpm. This corresponds to 100% and at the same time the user-defined value of 10,000 bottles per hour (see 6.11.7).

Changing the reference value to 50% will automatically result in a change of the other value to 5,000 bottles per hour.

The table below shows the relationship of reference values. In the event of a change, the other parameters are overwritten automatically.

| Parameters with same value | N.  | Dimensions                         |
|----------------------------|-----|------------------------------------|
| <b>Ramp ref 1</b>          | 44  | according to the Factor function % |
| <b>Ramp ref 1 (%)</b>      | 47  |                                    |
| <b>Speed input var*</b>    | 44  |                                    |
| <b>Speed input perc*</b>   | 46  |                                    |
| <b>Ramp ref 2</b>          | 48  | according to the Factor function % |
| <b>Ramp ref 2 (%)</b>      | 49  |                                    |
| <b>Speed ref 1</b>         | 42  | according to the Factor function % |
| <b>Speed ref 1 (%)</b>     | 337 |                                    |
| <b>Speed ref var*</b>      | 115 |                                    |
| <b>Percent ref var*</b>    | 116 |                                    |
| <b>Speed ref 2</b>         | 43  | according to the Factor function % |
| <b>Speed ref 2 (%)</b>     | 338 |                                    |

\* Defined in the DRIVECOM menu

### 6.4.1 Ramp ref

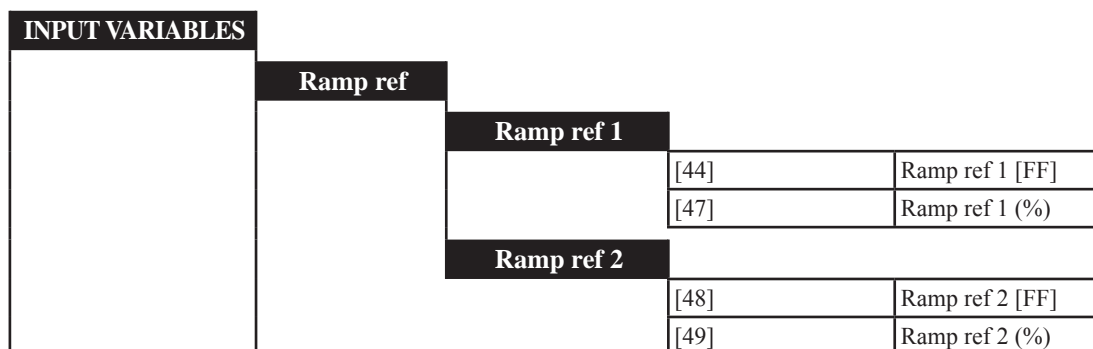

The ramp reference value specifies the speed the drive should reach once the acceleration phase has been completed. Modifications to the ramp reference value are therefore transferred to the ramp accordingly. The height of the ramp reference value determines the motor speed. As for the four quadrant drives (TPD32...4B...) the rotation direction is determined by the reference polarity.

#### Note!

Two quadrant TPD32...2B... drives accept only positive references. Negative values are not considered!

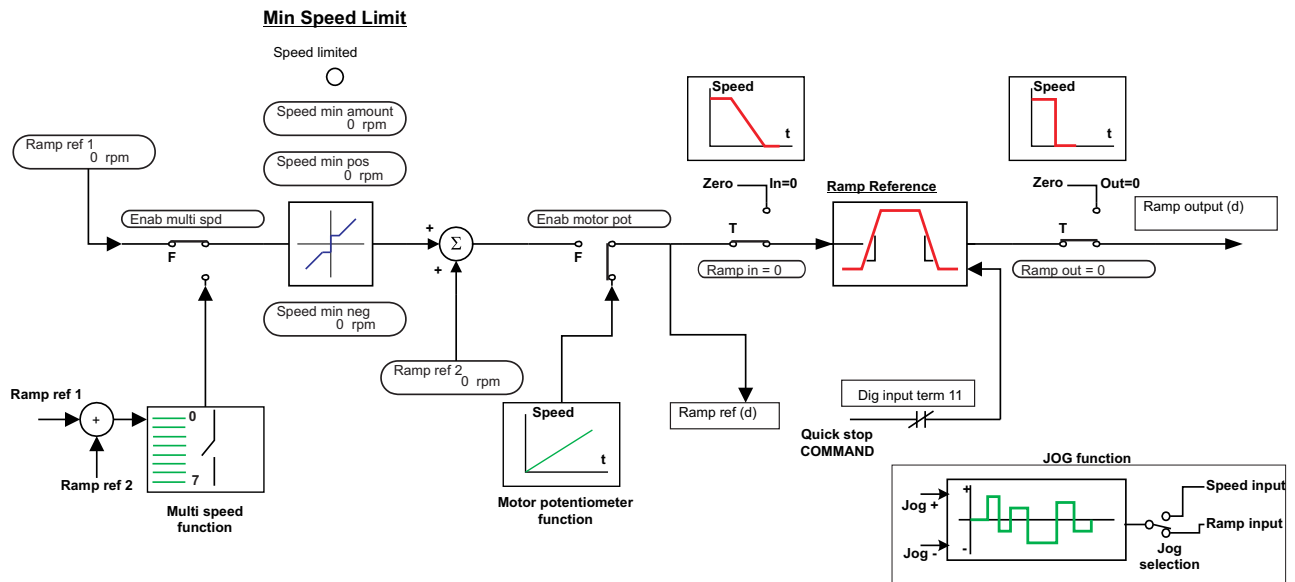

Figure 6.4.1.1: Ramp references

| Parameter description    | No. | Value  |        |                  |                  | Standard Configuration         |
|--------------------------|-----|--------|--------|------------------|------------------|--------------------------------|
|                          |     | min    | max    | Factory American | Factory European |                                |
| <b>Ramp ref 1 [FF]</b>   | 44  | -2 P45 | +2 P45 | 0                | 0                | An. Input 1 (Terminals 1 + 2)* |
| <b>Ramp ref 1 (%)</b>    | 47  | -200.0 | +200.0 | 0.0              | 0.0              |                                |
| <b>Ramp ref 2 [FF]</b>   | 48  | -2 P45 | +2 P45 | 0                | 0                | *                              |
| <b>Ramp ref 2 (%)</b>    | 49  | -200.0 | +200.0 | 0.0              | 0.0              |                                |
| <b>Ramp ref (rpm)</b>    | 110 | -32768 | +32767 | -                | -                | **                             |
| <b>Ramp ref (d) [FF]</b> | 109 | -32768 | +32767 | -                | -                |                                |
| <b>Ramp ref (%)</b>      | 111 | -32768 | -200.0 | +200.0           | -                |                                |

\* This function can be assigned to one of the programmable analog inputs. The converter is already factory set for a configuration using the terminals stated. The setting can also be modified to suit the application at hand.

\*\* This parameter can be assigned to a programmable analog output.

- Ramp ref 1** 1st reference value for the ramp. The value to be entered depends on the factor function.
- Ramp ref 1 (%)** 1st reference value as a percentage of the **Speed base value**
- Ramp ref 2** 2nd reference value for the ramp. The value to be entered depends on the factor function.
- Ramp ref 2 (%)** 2nd reference value as a percentage of the **Speed base value**
- Ramp ref (rpm)** Total reference value for the ramp in rpm (revolutions per minute)
- Ramp ref (d)** Total reference value for the ramp in the dimension specified by the factor function.
- Ramp ref (%)** Total reference value of the ramp as a percentage of the **Speed base value**

The total Ramp reference value **Ramp ref** consists of the signed addition of **Ramp ref 1** and **Ramp ref 2** (see Figure 6.4.1.1).

**Note:** Speed base value cannot exceed 8192 rpm.

Example 1: **Ramp ref 1** = + 50 % **Ramp ref 2** = + 30 %  
Ramp ref = 50 % + 30 % = 80 %

Example 2: **Ramp ref 1** = + 40 % **Ramp ref 2** = - 60 %  
**Ramp ref** = 40 % - 60 % = - 20 %

0 ... 10 V, 0 ... 20 mA and 4 ... 20 mA signals can be used when setting the reference value via terminals.

The **Ramp ref (rpm)**, **Ramp ref (d)** and **Ramp ref (%)** are influenced by the minimum speed limits. These are directly applied on the **Ramp ref 1**, as well as the Motor potentiometer and Multispeed references.

## 6.4.2 Speed ref

| INPUT VARIABLES    |                  |
|--------------------|------------------|
| <b>Speed ref</b>   |                  |
| <b>Speed ref 1</b> |                  |
| [42]               | Speed ref 1 [FF] |
| [378]              | Speed ref 1 (%)  |
| <b>Speed ref 2</b> |                  |
| [43]               | Speed ref 2 [FF] |
| [379]              | Speed Ref 2 (%)  |

The speed reference value specifies the required speed of the drive. The drive responds to the reference value progression directly, except in cases where the torque available is insufficient for this purpose. In this case, the drive operates at current limit until the selected speed has been reached. The speed reference value determines the speed of the motor, while the polarity determines the direction of rotation.

**Note!** Two quadrant TPD32...2B drives accept only positive references. Negative values are not considered!

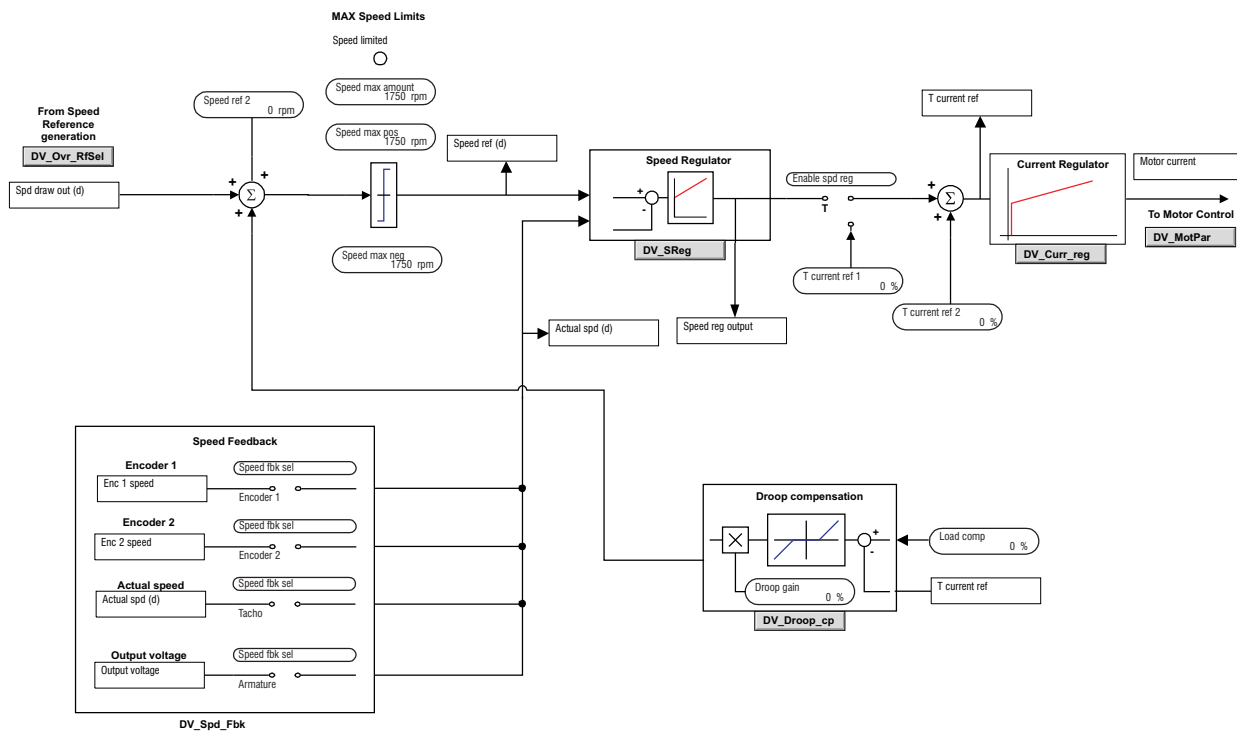

Figure 6.4.2.1: Speed reference

| Parameter description     | No. | Value  |        |                  |                  | Standard Configuration |
|---------------------------|-----|--------|--------|------------------|------------------|------------------------|
|                           |     | min    | max    | Factory American | Factory European |                        |
| <b>Speed ref 1 [FF]</b>   | 42  | -2 P45 | +2 P45 | 0                | 0                | Ramp output *          |
| <b>Speed ref 1 (%)</b>    | 378 | -200.0 | +200.0 | 0.0              | 0.0              |                        |
| <b>Speed ref 2 [FF]</b>   | 43  | -2 P45 | +2 P45 | 0                | 0                | *                      |
| <b>Speed Ref 2 (%)</b>    | 379 | -200.0 | +200.0 | 0.0              | 0.0              |                        |
| <b>Speed ref (rpm)</b>    | 118 | -32768 | +32767 | -                | -                | **                     |
| <b>Speed ref (d) [FF]</b> | 115 | -32768 | +32767 | -                | -                |                        |
| <b>Speed ref (%)</b>      | 117 | -32768 | -200.0 | +200.0           | -                |                        |

\* This function can be assigned to one of the programmable analog inputs.

\*\* This parameter can be assigned to a programmable analog output.

|                        |  |
|------------------------|--|
| <b>Speed ref 1</b>     | 1st reference value for the speed. The value to be entered depends on the factor function. |
| <b>Speed ref 1 (%)</b> | 1st speed reference value as a percentage of the <b>Speed base value</b>                   |
| <b>Speed ref 2</b>     | 2nd reference value for the speed. The value to be entered depends on the factor function. |
| <b>Speed ref 2 (%)</b> | 2nd speed reference value as a percentage of the <b>Speed base value</b>                   |
| <b>Speed ref (rpm)</b> | Total speed reference value in rpm.  |
| <b>Speed ref (d)</b>   | Total speed reference value in the dimension specified by the factor function.             |
| <b>Speed ref (%)</b>   | Total speed reference value as a percentage of the <b>Speed base value</b> .               |

The total speed reference value consists of the signed addition of **Speed ref 1** and **Speed ref 2**.

**Note:** Speed base value cannot exceed 8192 rpm.

Example 1:            **Speed ref 1** = + 50 %    **Speed ref 2** = + 30 %  
**Speed ref** = 50 % + 30 % = 80 %

Example 2:            **Speed ref 1** = + 40 %    **Speed ref 2** = - 60 %  
**Speed ref** = 40 % - 60 % = - 20 %

0 ... 10 V, 0 ... 20 mA and 4 ... 20 mA signals can be used when setting the reference value via terminals. The speed reference value has an upper and a lower limit.

If the ramp is selected, (**Enable ramp** parameter= Enabled), the reference value input **Speed ref 1** is automatically linked with the ramp output.

### 6.4.3 Torque current reference (*T current ref*)

| INPUT VARIABLES      |                     |
|----------------------|---------------------|
| <b>T current ref</b> |                     |
| [39]                 | T current ref 1 [%] |
| [40]                 | T current ref 2 [%] |

The current reference value is proportional to the armature current of the motor and determines the torque, the polarity determines the torque direction. For most applications **T current Ref** comes from the speed regulator output. **T current ref 2** can also be used as a correction value.

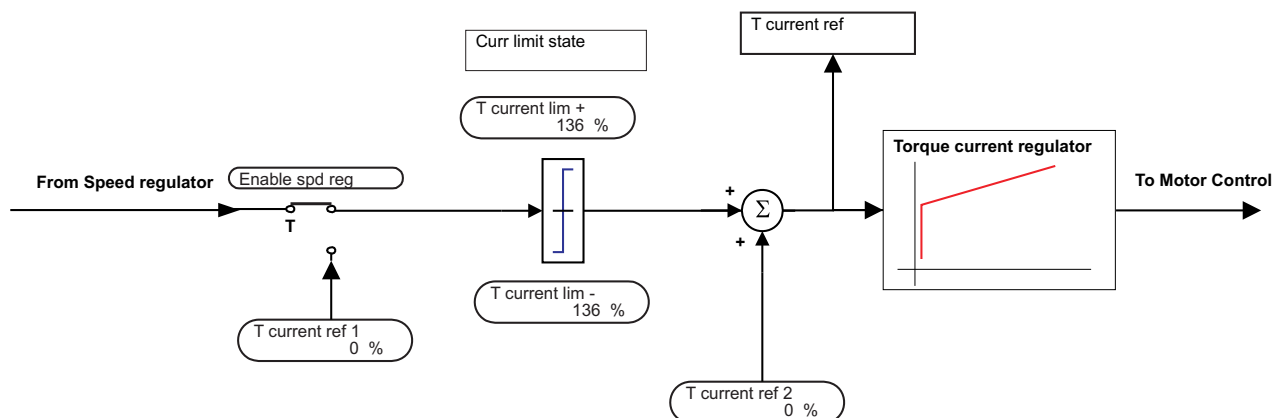

Figure 6.4.3.1: Torque current reference

| Parameter description      | No. | Value |                   |                  |                  | Standard Configuration   |
|----------------------------|-----|-------|-------------------|------------------|------------------|--------------------------|
|                            |     | min   | max               | Factory American | Factory European |                          |
| <b>T current ref 1 [%]</b> | 39  | -200  | +200<br>see 6.4.3 | 0                | 0                | Speed regulator output * |
| <b>T current ref 2 [%]</b> | 40  | -200  | +200              | 0.00             | 0.00             | *                        |
| <b>T current ref [%]</b>   | 41  | -200  | +200              | -                | -                | **                       |

\* This function can be assigned to one of the freely programmable analog inputs.

\*\* This parameter can be assigned to a freely programmable analog output.

**T current ref 1** 1st current reference value as a percentage of the **Full load curr**. The maximum value possible depends on the **Enable overload** parameter.

**Enable overload** disabled **T current ref 1** 100% max

**Enable overload** enabled **T current ref 1** 200% max

**T current ref 2** 2nd current reference value as a percentage of the **Full load curr**. The maximum value possible depends on the **Enable overload** parameter.

**Enable overload** disabled **T current ref 2** 100% max

**Enable overload** enabled **T current ref 2** 200% max

**T current Ref** Total current reference value as a percentage of the **Full load curr** value.

The total current reference value consists of the signed addition of **T current ref 1** and **T current Ref 2**.

Example 1: **T current ref 1** = +50% **T current ref 2** = +30%  
**T current ref** = 50% + 30% = 80%

Example 2: **T current ref 1** = +40% **T current ref 2** = -60%  
**T current ref** = 40-60% = -20%

0 ... 10 V, 0 ... 20 mA and 4 ... 20 mA signals can be used when setting the reference value via terminals. Reference set using input current, usually are with sign positive and they are used with biquadrant drives.

The current reference value has an upper limit.

## 6.5 LIMITS

### 6.5.1 Speed Limits

| LIMITS |               |                       |
|--------|---------------|-----------------------|
|        | Speed limits  |                       |
|        | Speed amount  |                       |
|        | [1]           | Speed min amount [FF] |
|        | [2]           | Speed max amount [FF] |
|        | Speed min/max |                       |
|        | [5]           | Speed min pos [FF]    |
|        | [3]           | Speed max pos [FF]    |
|        | [6]           | Speed min neg [FF]    |
|        | [4]           | Speed max neg [FF]    |

| Parameter description                                       | No. | Value |       |                  |                  | Standard Configuration |
|---|-----|-------|-------|------------------|------------------|------------------------|
|   |     | min   | max   | Factory American | Factory European |                        |
| Speed min amount [FF]                                       | 1   | 0     | 232-1 | 0                | 0                | -                      |
| Speed max amount [FF]                                       | 2   | 0     | 232-1 | 5000             | 5000             | -                      |
| Speed min pos [FF]  | 5   | 0     | 232-1 | 0                | 0                | -                      |
| Speed max pos [FF]  | 3   | 0     | 232-1 | 5000             | 5000             | -                      |
| Speed min neg [FF]  | 6   | 0     | 232-1 | 0                | 0                | -                      |
| Speed max neg [FF]  | 4   | 0     | 232-1 | 5000             | 5000             | -                      |
| Speed limited<br>Speed not limited (0)<br>Speed limited (1) | 372 | 0     | 1     |                  |                  | *                      |

\* This function can be assigned to a programmable digital output.

**Speed min amount** It defines the minimum speed for both directions TPD32...4B. A value below minimum is not accepted, regardless of the reference value selected. This parameter effects the ramp input. If the **Speed min amount** parameter is changed, the Parameter **Speed min pos** and **Speed min neg** parameters are set to the same value. If any of these parameters are subsequently changed, the last change is valid. The value to be entered is based on the factor function.

**Speed max amount** It defines the maximum speed for both directions TPD32...4B... This parameter affects the speed regulator input and therefore takes into account both the reference values that come from the ramp as well as the direction of rotation (see Figure 6.4.2.1). If the **Speed max amount** parameter is changed, the **Speed max pos** and **Speed max neg** parameters are set to the same value. If any of these values is subsequently changed, the last change is valid. The value to be entered is based on the factor function.

**Speed min pos** It defines the minimum speed for the clockwise rotation of the motor. A value below minimum is not accepted, regardless of the reference value selected. This function effects the ramp input (see Figure 6.4.1.1). The value of the parameter to be entered is based on the factor function.

**Speed max pos** It defines the maximum speed for the clockwise rotation of the motor. This function affects the input of the speed regulator and therefore takes into account both the reference values that come from the ramp as well as the direction of rotation (see Figure 6.4.1.1). The value of the parameter entered is based on the factor function.

**Speed min neg** It defines the minimum speed for the counterclockwise rotation of the motor TPD32...4B... A value below minimum is not accepted, regardless of the reference value selected. This parameter effects the ramp input (see Figure 6.4.1.1). The value of the parameter entered is based on the factor function.

**Speed max neg** It defines the maximum speed for the counterclockwise rotation of the motor TPD32...4B... This parameter effects the input of the speed regulator and therefore takes into account both the reference values that come from the ramp as well as the direction of rotation (see Figure 6.4.1.1).The value of the parameter entered is based on the factor function.

**Speed limited** Message that indicates that the reference value, is currently limited by the entered minimum and maximum limit values.

High Reference value currently limited since the value entered is out of range of the limit values defined.

Low Reference value within the defined limit values.

**Note!** The **Speed min amount**, **Speed min pos** and **Speed min neg** parameters have an effect on the **Ramp ref 1** reference value, the motor potentiometer function and the multi-speed function. They do not, however, have an effect on the **Ramp ref 2** parameter!

### 6.5.2 Armature current limits (Current limits)

| LIMITS         |                      |
|----------------|----------------------|
| Current limits |                      |
| [715]          | T current lim type   |
| [7]            | T current lim [%]    |
| [8]            | T current lim + [%]  |
| [9]            | T current lim - [%]  |
| [10]           | In use Tcur lim+ [%] |
| [11]           | In use Tcur lim- [%] |
| [13]           | Current lim red [%]  |
| [342]          | Torque reduct        |

The current effects the input of the current regulator and only take into account the armature current.

| Parameter description   | No. | Value |     |                  |                  | Standard Configuration |
|---|-----|-------|-----|------------------|------------------|------------------------|
|   |     | min   | max | Factory American | Factory European |                        |
| <b>T current lim type</b><br>T lim +/- (0)<br>T lim mot gen (1)                   | 715 | 0     | 1   | 0                | 0                | -                      |
| <b>T current lim [%]</b>  | 7   | 0     | 200 | 150              | 150              | **                     |
| <b>T current lim + [%]</b>  | 8   | 0     | 200 | 150              | 150              | **                     |
| <b>T current lim - [%]</b>  | 9   | 0     | 200 | 150              | 150              | **                     |
| <b>Curr limit state</b><br>Curr. limit not reached (0)<br>Curr. limit reached (1) | 349 | 0     | 1   |                  |                  | Digital output 5 ***   |
| <b>In use Tcur lim+ [%]</b>   | 10  | 0     | 200 |                  |                  | -                      |
| <b>In use Tcur lim- [%]</b>   | 11  | 0     | 200 |                  |                  | -                      |
| <b>Current lim red [%]</b>  | 13  | 0     | 200 | 100              | 100              | -                      |
| <b>Torque reduct</b><br>Not active (0)<br>Active (1)                              | 342 | 0     | 1   | Not active (0)   | Not active (0)   | *                      |

\* This function can be assigned to one of the programmable digital inputs.

\*\* This parameter can be assigned to a programmable analog input.

\*\*\* This function can be assigned to one of the programmable digital outputs.



## T curr lim type

This parameters determines the behaviour of the drive in current limit condition.

T lim +/-

The active positive torque limit is T current lim and the active negative torque limit is T current lim -.

T lim mot/gen

With this selection 3 conditions are possible:

1 - If the motor speed  $> +1\%$  of **Motor max speed** the active positive torque limit is **T current lim+** and the active negative torque limit is T current lim-.

2 - If the motor speed  $< -1\%$  of **Motor max speed** the active positive torque limit is **T current lim-** and the active negative torque limit is T current lim+.

3 - If  $-1\%$  of **Motor max speed**  $<$  motor speed  $<$   $+1\%$  of **Motor max speed** the active positive torque limit is **T current lim+** and the active negative torque limit is T current lim+.

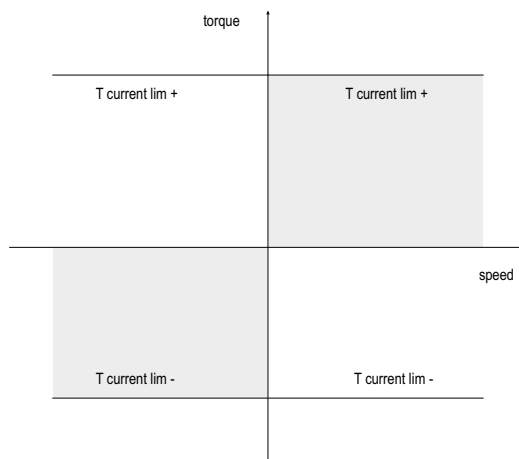

Figure 6.5.2.1: Torque limits with **T curr lim type = T lim +/-**

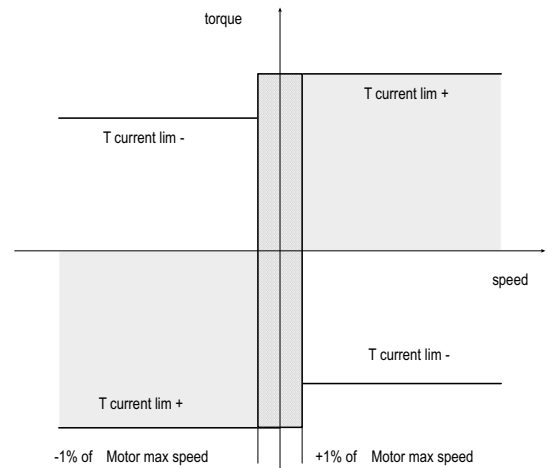

Figure 6.5.2.2: Torque limits with **T curr lim type = T lim mot/gen**

## T current lim

Symmetrical current limit for both current directions for TPD32...4B converters. Defined as a percentage of the **Full load curr** parameter. The maximum value depends on the **Enable overload** parameter.

**Enable overload** Disabled **T current limit** 100 % max

**Enable overload** Enabled **T current limit** 200% max

If the T current limit parameter is changed, the Parameter **T current lim +** and **T current lim -** parameters are set to the same value. If both these parameters are subsequently changed, the last change is valid.

## T current lim +

Setting of the drive current limit for the positive current direction (clockwise drive and counter-clockwise brake). Entered as a percentage of the **Full load curr** value. The maximum value depends on the value of the **Enable overload** parameter.

**Enable overload** Disabled **T current lim+** 100 % max

**Enable overload** Enabled **T current lim+** 200% max

## T current lim -

Setting of the drive current limit for the negative current direction (counterclockwise drive and clockwise brake). Entered as a percentage of the **Full load curr** parameter. The maximum value depends on the value of the **Enable overload** parameter. This parameter is not active for the TPD32...4B converters.

**Enable overload** Disabled **T current lim-** 100 % max

**Enable overload** Enabled **T current lim-** 200% max

## Curr limit state

Status message, indicating whether the drive is working with the set current limit or not.

High Drive working at the current limit. "I<sub>Limit</sub>" LED lights up.

Low Drive not working at the current limit.

|                          |  |
|--------------------------|--|
| <b>In use Tcur lim +</b> | Status message, indicating the used value of the current limit for the positive torque direction as a percentage of <b>Full load curr</b> .  |
| <b>In use Tcur lim -</b> | Status message, indicating the used value of the current limit for the negative torque direction as a percentage of <b>Full load curr</b> .  |
| <b>Current lim red</b>   | Setting of the armature current limit, as % of Full load curr, when the Torque reduct function is active.  |
| <b>Torque reduct</b>     | Selection for torque reduction. This function can be assigned to a freely programmable digital input. When the torque reduction function is active, the current limit changes accordingly by the percentage defined with the <b>Current lim red</b> parameter.<br>High                      Torque reduction not active<br>Low                         Torque reduction active |

Example of the function of the **Current lim red** and **Torque reduct** parameters.

**T current limit** (or **T current lim +/-**) = 80 %

**Current lim red** = 70 %

**Torque reduct** = High (not active)              Current limit = 80 %

**Torque reduct** = Low (active)                      Current limit = 70 %

The value for **T current limit** can be set in the START UP\Limits menu.

### 6.5.3 Flux limits

| LIMITS |                      |
|--------|----------------------|
|        | <b>Flux limits</b>   |
| [467]  | Flux current max [%] |
| [468]  | Flux current min [%] |

| Parameter description       | No. | Value |      |                  |                  | Standard Configuration |
|-----------------------------|-----|-------|------|------------------|------------------|------------------------|
|                             |     | min   | max  | Factory American | Factory European |                        |
| <b>Flux current max [%]</b> | 467 | P468  | 100  | 100              | 100              | */**                   |
| <b>Flux current min [%]</b> | 468 | 0     | P467 | 5                | 5                | -                      |

\* This parameter can be set on a programmable analogic outputs.

\*\* This parameter can be set on a programmable analogic input.

The limits regarding the field current are set in this submenu.

**Flux current max**              Percentage of maximum field current according to the **Motor nom flux** parameter.  
The max. value (100%) corresponds to the circulation in the field circuit of the motor , of a current equal to the value set in **Motor nom flux**.  
If any curve has been set via **I field cnst** parameter, the variation of this parameter influences the field current in a linear way .  
(see Flux /if curve section 5.4.5)

**Flux current min**              Percentage of minimum field current according to the **Motor nom flux** parameter .  
Its value states the circulation in the field circuit of the motor , of a minimum current compared to the value set in **Motor nom flux**.  
The value set here affect the threshold of the “Field loss” alarm indication . The threshold is the half of **Flux current min**.

## 6.6 RAMP

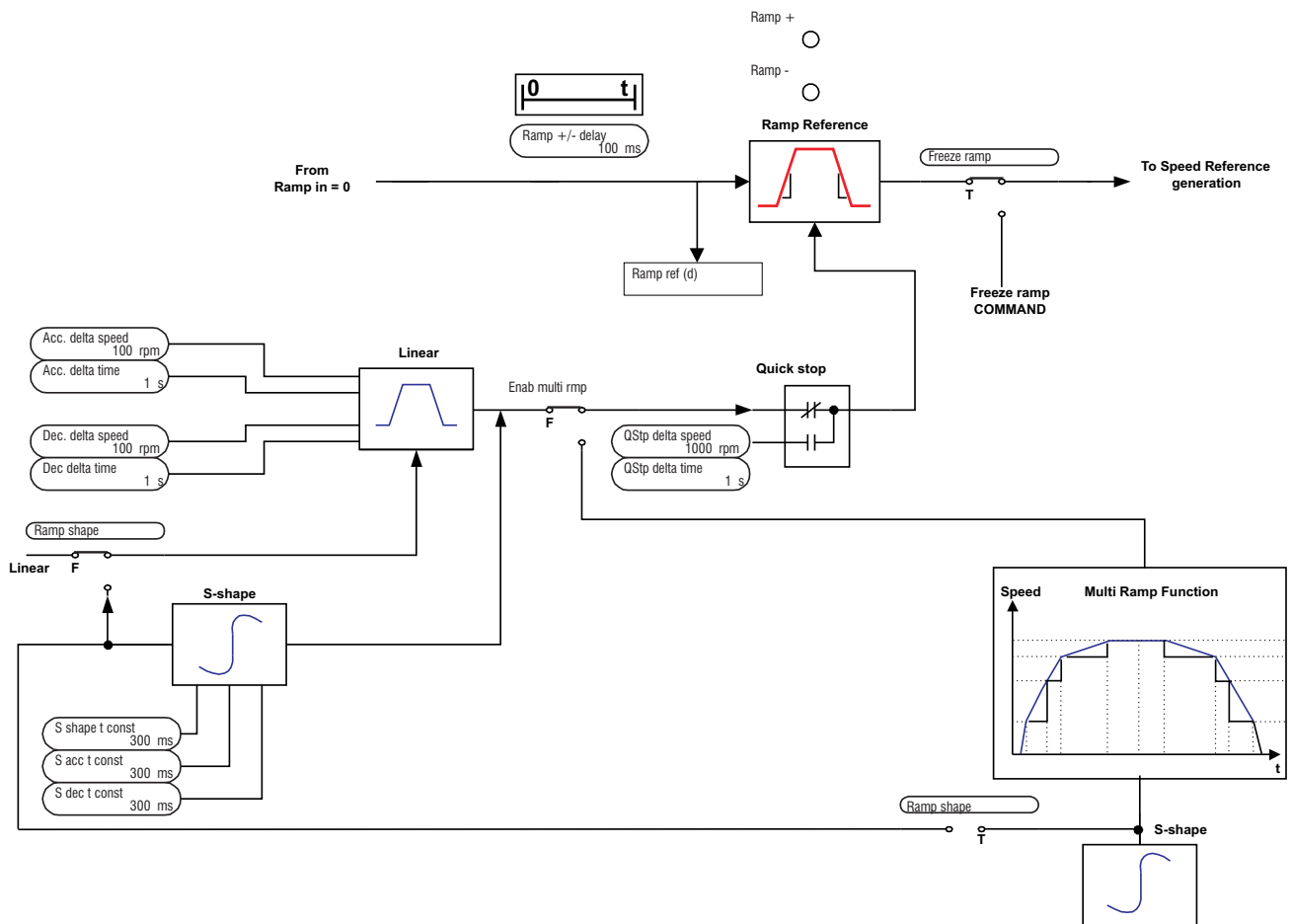

Figure 6.6.1 : Ramp circuit

The ramp (reference value integrator) determines the acceleration and deceleration times of the drive. These times can be set independently of each other.

An additional ramp is provided for a quick stop. This ramp can only be activated via the serial interface or a field bus.

The ramp can either be linear or S-shaped..

The reference values can be defined in different ways

- with the **Ramp ref 1** and/or **Ramp ref 2** reference values
- with the multi-speed function
- with the motor potentiometer function
- with the Jog function

The Ramp generator can be used in a stand alone configuration. When the Ramp generator is disabled (**Enable ramp** = disabled), the **Enable drive**, **Start/Stop** and **Fast stop** commands have no more influence on Ramp generator. In such a condition it is free to run and can be used separately.

## 6.6.1 Acceleration, Deceleration, Quick Stop

| RAMP                |      |                       |
|---------------------|------|-----------------------|
| <b>Acceleration</b> |      |                       |
|                     | [21] | Acc delta speed [FF]  |
|                     | [22] | Acc delta time [s]    |
| <b>Deceleration</b> |      |                       |
|                     | [29] | Dec delta speed [FF]  |
|                     | [30] | Dec delta time [s]    |
| <b>Quick stop</b>   |      |                       |
|                     | [37] | QStp delta speed [FF] |
|                     | [38] | QStp delta time [s]   |

| Parameter description | No. | Value |       |                  |                  | Standard Configuration |
|-----------------------|-----|-------|-------|------------------|------------------|------------------------|
|                       |     | min   | max   | Factory American | Factory European |                        |
| Acc delta speed [FF]  | 21  | 0     | 232-1 | 100              | 100              | -                      |
| Acc delta time [s]    | 22  | 0     | 65535 | 1                | 1                | -                      |
| Dec delta speed [FF]  | 29  | 0     | 232-1 | 100              | 100              | -                      |
| Dec delta time [s]    | 30  | 0     | 65535 | 1                | 1                | -                      |
| QStp delta speed [FF] | 37  | 0     | 232-1 | 1000             | 1000             | -                      |
| QStp delta time [s]   | 38  | 0     | 65535 | 1                | 1                | -                      |

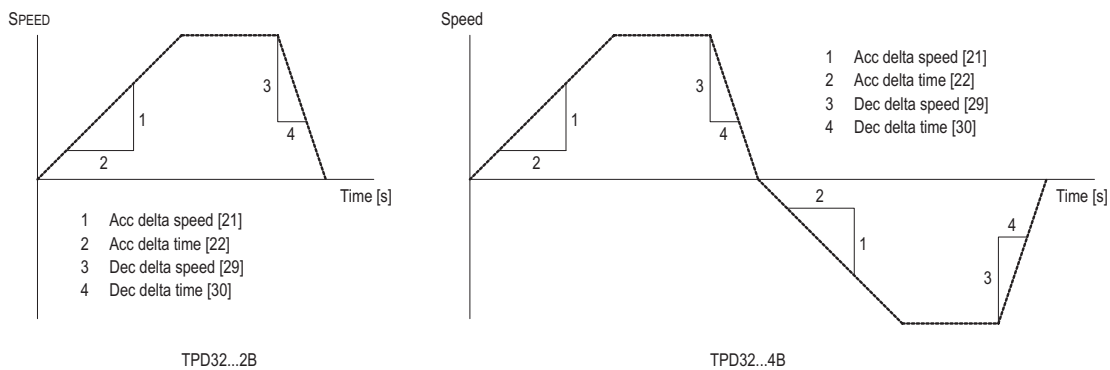

Figure 6.6.1.1: Accel, decel and Quick stop

|                         |   |
|-------------------------|---|
| <b>Acc delta speed</b>  | Has the same units as the ramp reference value and is based on the factor function.               |
| <b>Acc delta time</b>   | Is defined in seconds. If “0 s” is entered, the ramp output directly follows the reference value. |
| <b>Dec delta speed</b>  | Has the same units as the ramp reference value and is based on the factor function.               |
| <b>Dec delta time</b>   | Is defined in seconds. If “0s” is entered, the ramp output directly follows the reference value.  |
| <b>Qstp delta speed</b> | Has the same dimension as the ramp reference value and is based on the factor function.           |
| <b>Qstp delta time</b>  | Is defined in seconds. If “0 s” is entered, the ramp output follows the reference value.          |
| <b>Quick stop</b>       | Activates the Quick stop ramp   |

The acceleration of the drive is defined as a quotient of the **Acc delta speed** and **Acc delta time** parameters (see Figure 6.6.1.1). As for the four quadrant converters (TPD32...4B...) it is the same for both directions of rotation.

The deceleration of the drive is defined as a quotient of the parameters **Dec delta speed** and **Dec delta time** (see Figure 6.6.1.1). As for the four quadrant converters (TPD32...4B...) it is the same for both directions of rotation.

The Quick Stop function provides the possibility of a second deceleration ramp for the emergency braking of the drive. The ramp output in this case is not set to zero immediately but after a set time. The deceleration of the drive via the Quick Stop function is defined as the quotient of the **Qstp delta speed** and **Qstp delta time** parameters. As for the four quadrant converters (TPD32...4B...) it is the same for both directions of rotation. This ramp is activated by the functions **Fast stop** (via terminals) and **Quick stop**.

## 6.6.2 Ramp shape and control commands

| RAMP  |                      |
|-------|----------------------|
| [18]  | Ramp shape           |
| [19]  | S shape t const [ms] |
| [663] | S acc t const [ms]   |
| [664] | S dec t const [ms]   |
| [20]  | Ramp +/- delay [ms]  |
| [673] | Fwd-Rev              |
| [245] | Enable ramp          |
| [344] | Ramp out = 0         |
| [345] | Ramp in = 0          |
| [373] | Freeze ramp          |

| Parameter description  | No. | Value |       |                  |                  | Standard Configuration |
|--|-----|-------|-------|------------------|------------------|------------------------|
|  |     | min   | max   | Factory American | Factory European |                        |
| <b>Ramp shape</b><br>Linear (0)<br>S-Shaped (1)  | 18  | 0     | 1     | Linear (0)       | Linear (0)       | -                      |
| <b>S shape t const [ms]</b>  | 19  | 100   | 3000  | 300              | 300              | -                      |
| <b>S acc t const [ms]</b>  | 663 | 100   | 3000  | 300              | 300              | -                      |
| <b>S dec t const [ms]</b>  | 664 | 100   | 3000  | 300              | 300              | -                      |
| <b>Ramp +/- delay [ms]</b>   | 20  | 0     | 65535 | 100              | 100              | -                      |
| <b>Fwd-Rev</b><br>No direction (0)<br>Fwd direction (1)<br>Rev direction (2)<br>No direction (3) | 673 | 0     | 3     | 1                | 1                | -                      |
| <b>Forward sign</b>  | 293 | 0     | 1     | 0                | 0                | -                      |
| <b>Reverse sign</b>  | 294 | 0     | 1     | 0                | 0                | -                      |
| <b>Enable ramp</b><br>Enabled (1)<br>Disabled (0)  | 245 | 0     | 1     | Enabled (1)      | Enabled (1)      | -                      |
| <b>Ramp out = 0</b><br>Active (0)<br>Not active (1)  | 344 | 0     | 1     | Not active (1)   | Not active (1)   | *                      |
| <b>Ramp in = 0</b><br>Active (0)<br>Not active (1)   | 345 | 0     | 1     | Not active (1)   | Not active (1)   | *                      |
| <b>Freeze ramp</b><br>Active (0)<br>Not active (1)   | 373 | 0     | 1     | Not active (1)   | Not active (1)   | *                      |
| <b>Ramp +</b><br>Acc.CW + Dec. anti-CW (1)<br>Other states (0)                                   | 346 | 0     | 1     | -                | -                | Digital output 1 *     |
| <b>Ramp -</b><br>Acc.anti-CW + Dec. CW (1)<br>Other states (0)                                   | 347 | 0     | 1     | -                | -                | Digital output 2 *     |

\* This function can be assigned to one of the programmable digital inputs.

\*\* This parameter can be assigned to a programmable digital output.

\*\*\* This function can be assigned to one of the programmable analog outputs.

The shape of the ramp is determined by the **Ramp shape**, **S shape t constant**, **S dec t const** parameters.

**Ramp shape**                      Linear                      Linear ramp  
     S shaped                      S-shaped ramp

**S shape t const**

Determines the curve for S-shaped ramps (see Figure 6.6.2.1).

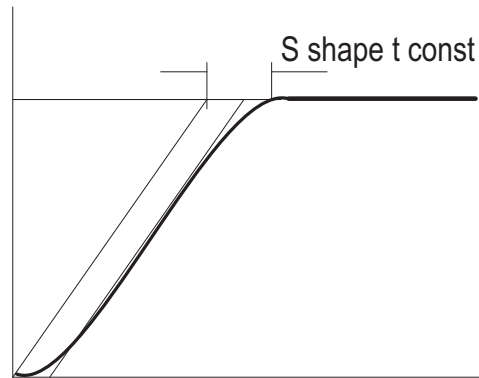

Figure 6.6.2.1: Ramp shape

The value of **S shape t constant** is added to the ramp time of linear ramps. The ramp time is thus lengthened by the value defined by the **S shape t const** parameter. This is done regardless of the speed changed involved!

**S acc t const** Determines the curve for S-shaped acceleration ramps.

**S dec t const** Determines the curve for S-shaped deceleration ramps.

Using very different **S acc t const** and **S dec t const** values it is possible to have a discontinuous behaviour during the changing of the motor direction.

Speed changes (=Active ramp) are indicated by the **Ramp +** and **Ramp -** parameters.

**Ramp +/- delay** Defines a delay time. It is only valid if the ramp is active.

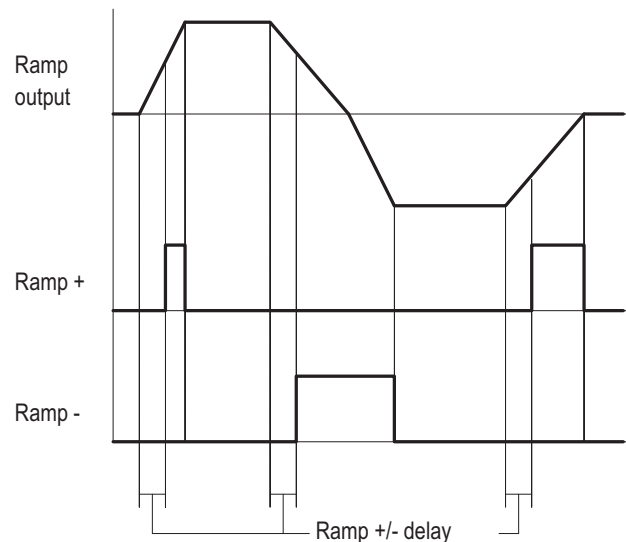

Figure 6.6.2.2: Ramp delay

**Fwd-Rev** Changes the sign of the Ramp reference. When Fwd direction is selected the Ramp reference is multiplied by +1. When Rev direction is selected the Ramp reference is multiplied by -1.

**Forward sign** Set the Fwd direction of the Ramp reference. It can be programmed on a digital input.

**Reverse sign** Set the Rev direction of the Ramp reference. It can be programmed on a digital input.

When both Fwd and Rev sign are 0 or 1, or **Fwd-Rev** is 0 or 1, the multiplexer is 0.

The behavior of the ramp circuit is defined by the **Enable Ramp**, **Ramp In = 0**, **Ramp Out = 0** and **Freeze ramp** parameters.

**Enable Ramp** This parameter can be changed only with a disabled drive.

- Enabled The ramp is enabled.
- Disabled The ramp is disabled.

**Ramp out = 0** Not active (H) Enabled ramp output.

- Active (L) The ramp output is immediately set to zero.

**Ramp in = 0** Not active (H) Enabled ramp input. The **Ramp Ref** parameter corresponds to the set reference.

- Active (L) Disabled ramp input. **Ramp Ref = 0**

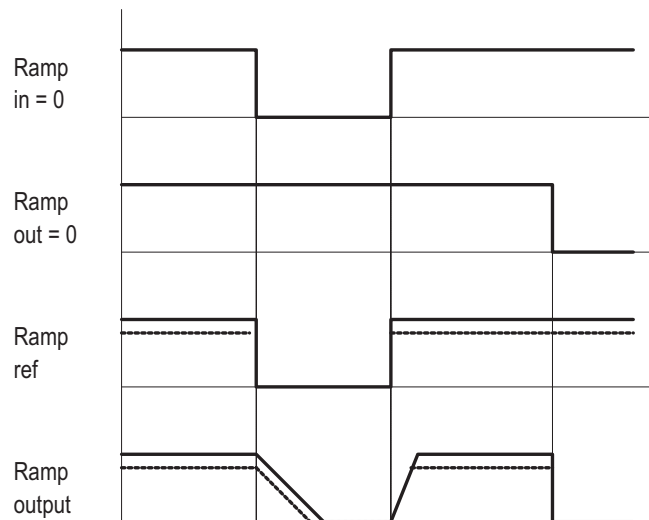

Figure 6.6.2.3: Ramp control

**Freeze ramp** Not active (H) The value at the ramp output is kept, irrespective of any possible reference value changes at the ramp input.

- Active (L) The ramp output follows the reference value changes at the ramp input according to the times set.

**Ramp +** Active if the drive uses a positive torque (clockwise rotation and counter-clockwise braking).

**Ramp -** Active if the drive uses a negative torque (counter-clockwise rotation and clockwise braking). Only for TPD32...4B...

Drive operation is only possible with the ramp function enabled. **Enable ramp**=Enabled.

When the ramp input is enable via **Ramp in = 0**, the acceleration time of the drive starts. If the input is disabled, the drive slows down according to the deceleration time set until zero speed is reached.

When the ramp output is set to zero via **Ramp out = 0**, the drive brakes through the maximum available torque. With the TPD32...2B converters no braking is possible. The function (also Quick Stop) causes the motor to coast.

## 6.7 SPEED REGULATION (SPEED REGULAT)

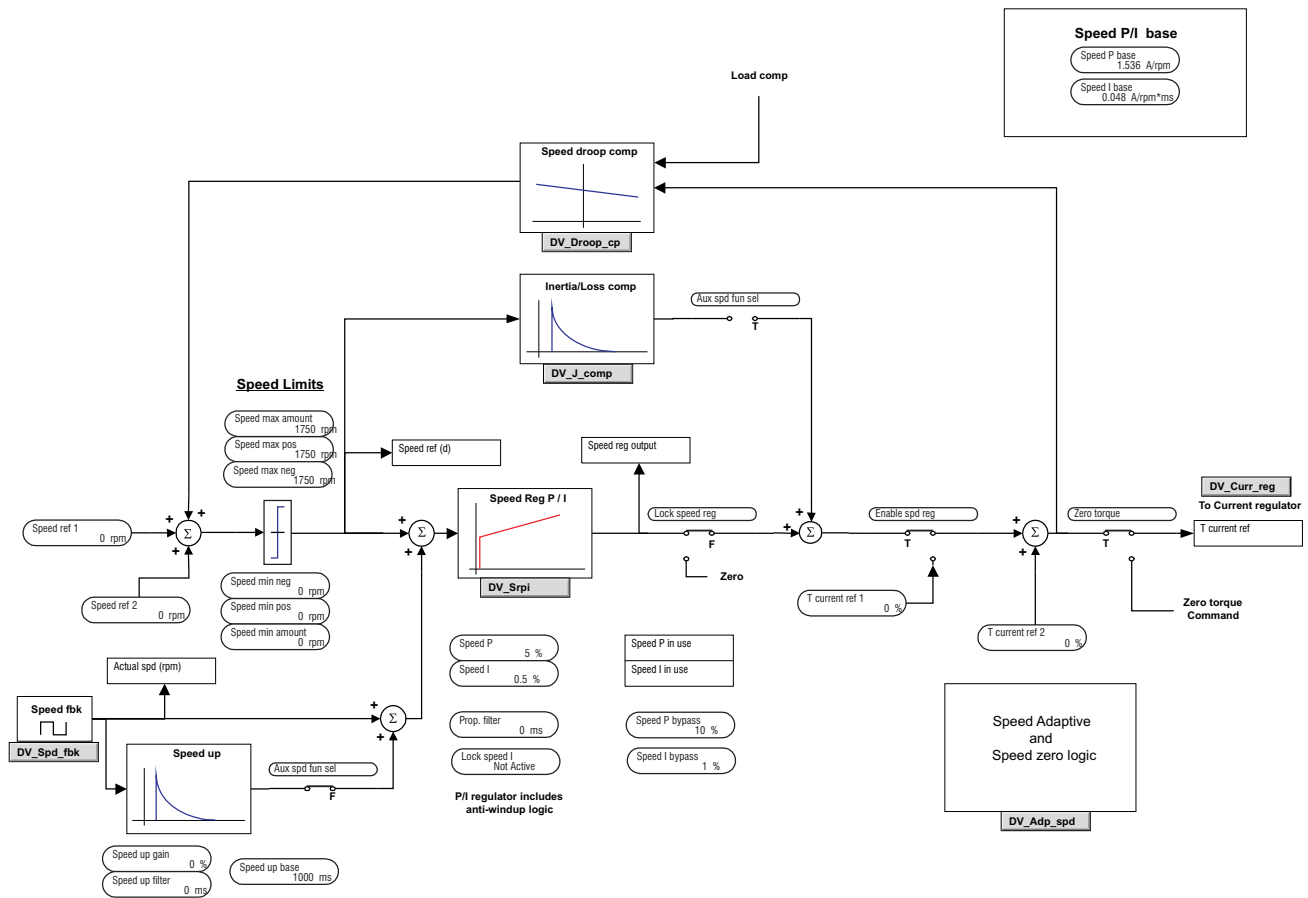

Figure 6.7.1: Speed regulation

The converters of the TPD32 series are provided with a speed regulator circuit that can adapt flexibly to the requirements of various applications. The device is factory set for PI regulation and regulator parameters that stay the same throughout the entire speed range.

The following functions are also provided:

- “Speed-up” function in order to avoid oscillations in presence of loads with a high moment of inertia.
- Speed zero logic for regulator behavior when the motor is stopped.
- Speed regulator adaption for optimizing the regulator according to the actual speed or to an external reference (Adap Reference)..
- Auto capture function of a running motor
- Speed signals
- Droop function for current balancing

For the speed PI regulator diagram block, please refer to “Speed regulator PI part” block diagram on chapter 9.



## 6.7.1 Speed regulator

| SPEED REGULAT |                       |
|---------------|-----------------------|
| [118]         | Speed ref [rpm]       |
| [236]         | Speed reg output [% ] |
| [322]         | Lock speed reg        |
| [242]         | Enable spd reg        |
| [348]         | Lock speed I          |
| [1016]        | Aux spd fun sel       |
| [444]         | Prop filter [ms]      |

| Parameter description                                  | No.  | Value  |                   |                  |                  | Standard Configuration |
|--|------|--------|-------------------|------------------|------------------|------------------------|
|  |      | min    | max               | Factory American | Factory European |                        |
| Speed ref [rpm]  | 118  | -32768 | +32767            | -                | -                | **                     |
| Speed reg output [% ]                                  | 236  | -200   | +200<br>see 6.7.1 | -                | -                | T current ref 1 **     |
| Lock speed reg<br>ON (1)<br>OFF (0)                    | 322  | 0      | 1                 | OFF              | OFF              | *                      |
| Enable spd reg<br>Enable (1)<br>Disable (0)            | 242  | 0      | 1                 | Enabled          | Enabled          | -                      |
| Lock speed I<br>Active (0)<br>Not active (1)           | 348  | 0      | 1                 | Not active (1)   | Not active (1)   | *                      |
| Aux spd fun sel<br>Speed up (0)<br>Inertia-loss cp (1) | 1016 | 0      | 1                 | Speed up (0)     | Speed up (0)     |                        |
| Prop filter [ms]                                       | 444  | 0      | 1000              | 0                | 0                |                        |

\* This function can be assigned to one of the programmable digital inputs.

\*\* This parameter can be assigned to a programmable analog output.

|                         |  |
|-------------------------|--|
| <b>Speed ref</b>        | Total speed reference value in rpm   |
| <b>Speed reg output</b> | Output value of the speed regulator, used as the reference value for the current regulator<br><b>Note!</b> The speed regulator is still active even if disabled ( <b>Enable spd reg</b> = Disabled), therefore the <b>Speed reg output</b> contains valid information also in this case. Such a data can be transferred to the APC200 board to be used for other regulation. If the speed regulator is enabled ( <b>Enable spd reg</b> = Enabled) the <b>Speed reg output</b> contains the sum of the actual speed regulator output and <b>T current ref 2</b> .     |
| <b>Lock speed reg</b>   | This parameter is used in order to lock the speed regulator. When this happens, it stops to work, the current reference value is set to zero and the drive comes to a stop. This coasting time then depends on the rotating mass and the friction within the system concerned. If the connection between the speed regulator and the current regulator is restored, the drive will restart in the shortest possible time.<br>ON Speed regulator locked (= 0 V when using a digital input).<br>OFF Speed regulator unlocked (= 15...30 V when using a digital input). |
| <b>Enable spd reg</b>   | This parameter can only be changed when the drive is switched off.<br>Enabled The speed regulator is enabled. The regulator output is connected to the input of the current regulator. <b>Speed reg output = T current ref 1</b><br>Disabled The speed regulator is disabled.  |
| <b>Lock speed I</b>     | Not active (H) I component of the speed regulator is enabled<br>Active (L) I component of the speed regulator is disabled  |
| <b>Aux spd fun sel</b>  | Selection of the <i>Speed up</i> or <i>Inertia/loss cp</i> (see chapter 6.7.3. <i>Speed up function</i> and chapter 6.7.5. <i>Inertia/loss cp</i> for more details).   |

**Prop filter**

Time constant of the filter belonging to the circuit of the speed feedback. Filtering of the high frequency components of speed feedback signal is useful in case of elastic coupling between motor and load (joint or belts).

The speed regulator must be enabled with the **Enable spd reg** parameter in order for it to be used.

The reference value for the speed regulator consists of the signed addition of **Speed ref 1** and **Speed ref 2**.

The speed feedback is supplied by an encoder or a tachometer that are mounted to the motor shaft. The higher the resolution of the encoder, the better the control accuracy of the regulator.

The regulator parameters can be set separately.

For the speed PI regulator diagram block, please refer to diagram on chapter 9.

**6.7.1.1 Self tuning of Speed regulator**

| SPEED REGULAT |                      |
|---------------|----------------------|
| Self tuning   |                      |
| [1029]        | Fwd-Rev spd tune     |
| [1048]        | Test T curr lim [%]  |
| [1027]        | Start                |
| [1014]        | Inertia [kg*m*m*]    |
| [1030]        | Inertia Nw [kg*m*m*] |
| [1015]        | Friction [N*m]       |
| [1031]        | Friction Nw [N*m]    |
| [87]          | Speed P [%]          |
| [1032]        | Speed P Nw [%]       |
| [88]          | Speed I [%]          |
| [1033]        | Speed I Nw [%]       |
| [1028]        | Take val             |

| Parameter description   | No.  | Value |         |                      |                      | Standard Configuration |
|---|------|-------|---------|----------------------|----------------------|------------------------|
|   |      | min   | max     | Factory American     | Factory European     |                        |
| <b>Fwd-Rev spd tune</b><br>Fwd direction (1)<br>Rev direction (2) | 1029 | 1     | 2       | Fwd<br>Direction (1) | Fwd<br>Direction (1) |                        |
| <b>Test T curr lim [%]</b>  | 1048 | 0     | S       | 20                   | 20                   |                        |
| <b>Start</b>  | 1027 | 0     | 65535   | -                    | -                    |                        |
| <b>Inertia [kg*m*m*]</b>  | 1014 | 0.001 | 999.999 | S                    | S                    |                        |
| <b>Inertia Nw [kg*m*m*]</b>                                       | 1030 | 0.001 | 999.999 | -                    | -                    |                        |
| <b>Friction [N*m]</b>   | 1015 | 0.000 | 99.999  | S                    | S                    |                        |
| <b>Friction Nw [N*m]</b>  | 1031 | 0.00  | 99.99   | -                    | -                    |                        |
| <b>Speed P [%]</b>  | 87   | 0.00  | 100.00  | S                    | S                    |                        |
| <b>Speed P Nw [%]</b>   | 1032 | 0.00  | 100.00  | -                    | -                    |                        |
| <b>Speed I [%]</b>  | 88   | 0.00  | 100.00  | S                    | S                    |                        |
| <b>Speed I Nw [%]</b>   | 1033 | 0.00  | 100.00  | -                    | -                    |                        |
| <b>Take val</b>   | 1028 | 0     | 65535   | -                    | -                    |                        |

**Fwd-Rev spd tune**

Direction of motor shaft rotation for the speed self tune test (Forward or Reverse; Forward is clock-wise as seen from shaft drive end).

**Test T curr lim**

Torque current limit applied during Speed self tune test.

**Start**

Start-up speed self tune.

**Inertia**

Inertia value in Kg\*m<sup>2</sup> (1 Kg\*m<sup>2</sup> = 23.76 lb\*ft<sup>2</sup>).

**Inertia Nw**

New Inertia value in Kg\*m<sup>2</sup> identified during the speed self tune procedure.

**Friction**

Friction value (or Loss compensation) in N\*m (1 N\*m = 0.738 lb\*ft).

- Friction Nw** New Friction value (or Loss compensation) in N\*m identified during the speed self tune procedure.
- Speed P** Proportional coefficient of the speed regulator in percentage.
- Speed P Nw** New value of Proportional coefficient of the speed regulator in percentage computed during the speed self tune procedure.
- Speed I** Integral coefficient of the speed regulator in percentage.
- Speed I Nw** New value of Integral coefficient of the speed regulator in percentage computed during the speed self tune procedure.
- Take val** Acquire the parameters after the speed self tune procedure (overwrite current values).
- Note!** This is not a permanent save. Go to “Save parameters” command.

### 6.7.2 Spd zero logic

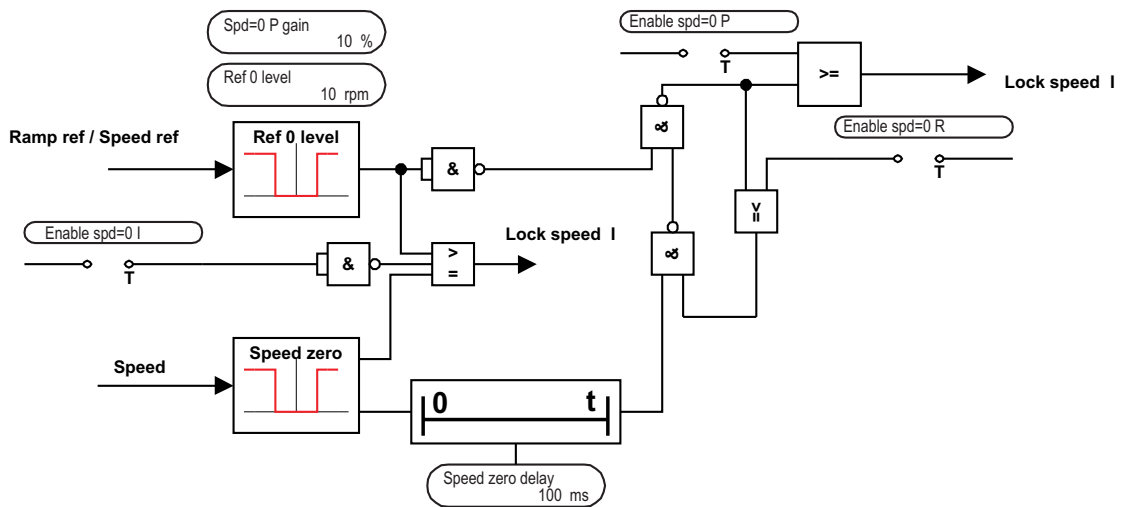

Figure 6.7.2.1: Speed zero logic

| SPEED REGULAT |       | Spd zero logic |                  |
|---------------|-------|----------------|------------------|
|               | [123] |                | Enable spd=0 I   |
|               | [124] |                | Enable spd=0 R   |
|               | [125] |                | Enable spd=0 P   |
|               | [126] |                | Spd=0 P gain [%] |
|               | [106] |                | Ref 0 level [FF] |

The speed zero logic determines the behavior of the drive when the motor shaft is at a stop.

| Parameter description                                | No. | Value |        |                  |                  | Standard Configuration |
|--|-----|-------|--------|------------------|------------------|------------------------|
|  |     | min   | max    | Factory American | Factory European |                        |
| <b>Enable spd=0 I</b><br>Enabled (1)<br>Disabled (0) | 123 | 0     | 1      | Disabled         | Disabled         | -                      |
| <b>Enable spd=0 R</b><br>Enabled (1)<br>Disabled (0) | 124 | 0     | 1      | Disabled         | Disabled         | -                      |
| <b>Enable spd=0 P</b><br>Enabled (1)<br>Disabled (0) | 125 | 0     | 1      | Disabled         | Disabled         | -                      |
| <b>Spd=0 P gain [%]</b>                              | 126 | 0.00  | 100.00 | 10.00            | 10.00            | -                      |
| <b>Ref 0 level [FF]</b>                              | 106 | 1     | 32767  | 10               | 10               | -                      |

|                       |   |  |
|-----------------------|---|--|
| <b>Enable spd=0 I</b> | Enabled   | The I component of the speed regulator is set to 0 when the reference value and the actual value = 0. The drive control is then only proportional. The I component is enabled when a reference value is entered to restart acceleration. |
|                       | Disabled  | Disable the function.  |
| <b>Enable spd=0 R</b> | Only effective if <b>Enable spd=0 P</b> is enabled.   |  |
|                       | Enabled   | The proportional gain, equal to <b>Spd=0 P</b> gain at zero speed, is equal to <b>Speed P</b> when the speed reference becomes higher than the value defined by <b>Ref 0</b> level.  |
|                       | Disabled  | The proportional gain, equal to <b>Spd=0 P</b> gain at zero speed, is equal to <b>Speed P</b> when the speed reference or the actual speed become higher than the value defined by <b>Ref 0</b> level.                                   |
| <b>Enable spd=0 P</b> | Enabled   | When both reference value and actual value = 0, the proportional <b>Spd=0 P</b> gain component is active after the delay time defined by Speed zero delay.   |
|                       | Disabled  | The speed regulator also keeps its proportional gain component when the drive is at a stop.  |
| <b>Spd=0 P gain</b>   | Proportional gain of the speed regulator, that is only active when both reference value and actual value = 0, and if the <b>Enable spd=0 P</b> function has been enabled. |  |
| <b>Ref 0 level</b>    | Switch threshold for speed zero logic. Defined in the dimension specified in the factor function. Speeds below this threshold are defined as zero.                        |  |

### 6.7.3 Speed up

| SPEED REGULAT |                      |
|---------------|----------------------|
|               | <b>Speed up</b>      |
| [445]         | Speed up gain [%]    |
| [446]         | Speed up base [ms]   |
| [447]         | Speed up filter [ms] |

| Parameter description | No. | Value |        |                  |                  | Standard Configuration |
|-----------------------|-----|-------|--------|------------------|------------------|------------------------|
|                       |     | min   | max    | Factory American | Factory European |                        |
| Speed up gain [%]     | 445 | 0.00  | 100.00 | 0.00             | 0.00             | -                      |
| Speed up base [ms]    | 446 | 0     | 16000  | 1000             | 1000             | -                      |
| Speed up filter [ms]  | 447 | 0     | 1000   | 0                | 0                | -                      |

The Speed-up function is used in order to avoid oscillations in presence of loads with a high moment of inertia. It is made up of a derivative part in the speed feedback circuit, which allows to increase the integral gain of the speed regulator. It is also useful in case of cyclical non constant loads on the motor (ex. cams). The feedback applied to the speed regulator is made of two components:

- the motor speed
- the output signal from the Speed up function

This function is mutually exclusive to the **Inertia/loss comp** function, This selection must be done via the **Aux spd fun sel [1016]** parameter. (SPEED REGULAT menu). See section 6.7.1 Speed regulator.

|                        |   |
|------------------------|---|
| <b>Speed up gain</b>   | Speed up function gain as a percentage of <b>Speed up base</b>  |
| <b>Speed up base</b>   | Speed up function max. gain. The defined value corresponds to 100% of the <b>Speed up gain</b> parameter. |
| <b>Speed up filter</b> | Time constant of the filter belonging to the D part of the Speed up function.                             |

See example figure 5.3.7.3. and 5.3.7.4.

## 6.7.4 Droop function

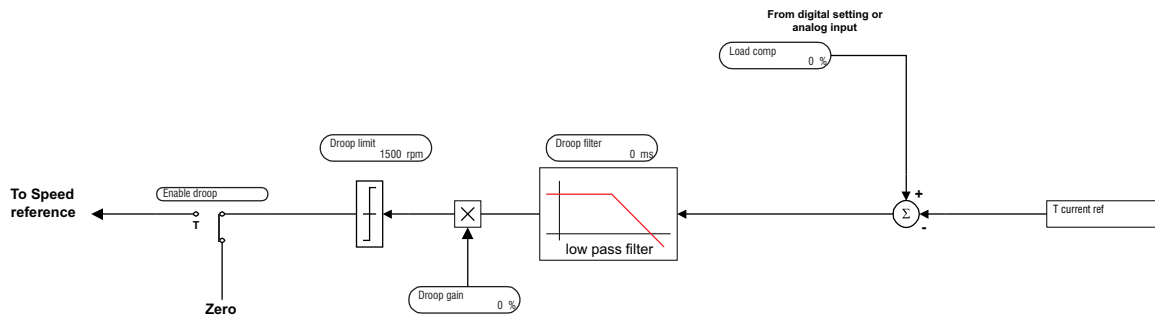

Figure 6.7.4.1: Droop compensation

### SPEED REGULAT

#### Droop function

|       |                   |
|-------|-------------------|
| [696] | Droop gain [%]    |
| [697] | Droop filter [ms] |
| [698] | Load comp [%]     |
| [700] | Droop limit [FF]  |
| [699] | Enable droop      |

| Parameter description                              | No. | Value |        |                  |                  | Standard Configuration |
|--|-----|-------|--------|------------------|------------------|------------------------|
|  |     | min   | max    | Factory American | Factory European |                        |
| <b>Droop gain [%]</b>                              | 696 | 0.00  | 100.00 | 0.00             | 0.00             |                        |
| <b>Droop filter [ms]</b>                           | 697 | 0     | 1000   | 0                | 0                |                        |
| <b>Load comp [%]</b>                               | 698 | -200  | +200   | 0                | 0                | *                      |
| <b>Droop limit [FF]</b>                            | 700 | 0     | 2*P45  | 1500             | 1500             | **                     |
| <b>Enable droop</b><br>Enabled (1)<br>Disabled (0) | 699 | 0     | 1      | Disabled (0)     | Disabled (0)     |                        |

\* This parameter can be assigned to one of the programmable analog inputs.

\*\* This parameter can be assigned to one of the programmable digital inputs.

The Droop function is used when a current balancing between two drives is required. A typical situation is when two motors are mechanically coupled and have to run at the same speed. If, because of a different characteristic of the two speed regulators, one of the motors is driven to run at a higher speed, it will be overloaded and the second motor will work as a brake. The Droop function permits to avoid this bad functioning by adding a component in the in the speed reference of the drive, which is proportional to the actual load difference of the drives. The effect is the balancing of the two motor current.

**Droop gain** Droop function gain. It is defined as a percentage of the ratio between **Speed base value** and the difference **Load comp - T current ref**. This means that when the difference **Load comp - T current ref** is 100% and **Droop gain** = 100%, the speed reference correction signal is equal to **Speed base value**.

**Droop filter** Filter time constant

**Load comp** Load compensation signal. It is typically equal to the “master” drive current, but it can also be assigned to a programmable analog output. It is defined as a percentage of Idn.

**Enable droop** Enabled Droop function enabled.  
Disabled Droop function disabled.

**Droop limit** It defines the speed reference correction range in which the droop function is active. The value to be entered is based on the factor function.

(For more detail see Figure 6.7.1 “Speed regulator”).

### EXAMPLE (PIPE MILL)

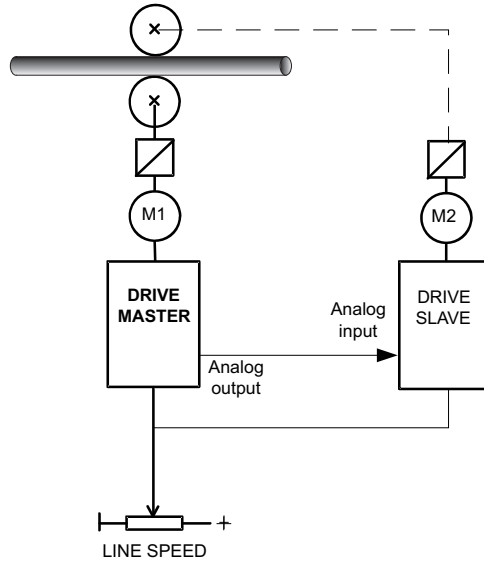

Figure 6.7.4.2: Droop function example

Example setting:

----> Purpose: Torque of motor 1 has to be equal to torque of motor 2

Drive Master

Analog input 1= Speed ref 1

Analog output 1= Tcurr ref

Drive slave

Analog input 1= Speed ref 1

Analog input 2= Load comp

Enable droop= enables

Droop gain= 5%

Droop filter= 100ms

Droop limit=1000

### 6.7.5 Inertia/Loss compensation

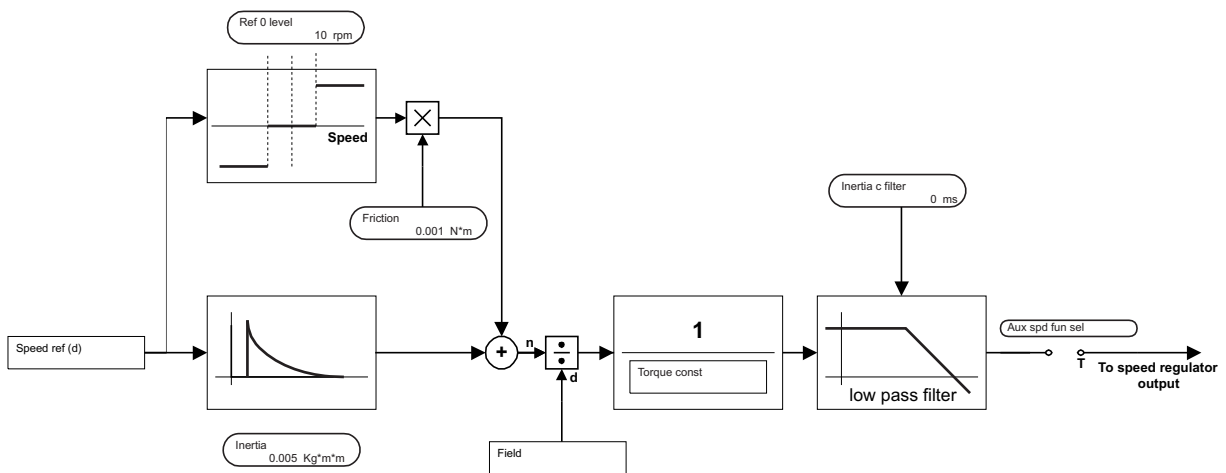

Figure 6.7.5.1: Inertia/Loss compensation

#### SPEED REGULAT

#### Inertia/loss cp

|        |                       |
|--------|-----------------------|
| [1014] | Inertia [kg*m*m]      |
| [1015] | Friction [N*m]        |
| [1013] | Torque const [N*m/A]  |
| [1012] | Inertia c filter [ms] |

| Parameter description        | No.  | Value |         |                  |                  | Standard Configuration |
|------------------------------|------|-------|---------|------------------|------------------|------------------------|
|                              |      | min   | max     | Factory American | Factory European |                        |
| <b>Inertia [kg*m*m]</b>      | 1014 | 0.001 | 999.999 | S                | S                |                        |
| <b>Friction [N*m]</b>        | 1015 | 0.000 | 99.999  | S                | S                |                        |
| <b>Torque const [N*m/A]</b>  | 1013 | 0.01  | 99.99   | S                | S                |                        |
| <b>Inertia c filter [ms]</b> | 1012 | 0     | 1000    | 0                | 0                |                        |

Speed regulator feedforward term that allows to increase the dynamic response to a speed reference variation. These parameters are identified from the **Speed self tune** function (START UP\Speed self tune and SPEED REGULAT\Self tuning) but they can also be set from the user.

This function is mutually exclusive to the Speed up function, This selection must be done via the **Aux spd fun sel [1016]** parameter. (SPEED REGULAT menu). See section 6.7.1, Speed regulator.

- Inertia** Total Inertia value at the motor shaft in Kg\*m<sup>2</sup> identified during the speed self tune procedure. (**1 Kg\*m<sup>2</sup> = 23.73 lb\*ft<sup>2</sup>**)
- Friction** Friction value (or Loss compensation) in N\*m identified during the speed self tune procedure. (**1 N\*m = 0.738 lb\*ft**)
- Torque const** Total torque constant value internally computed that allows to obtain the N\*m/A conversion when the motor operates within the specified speed range. This value is identified during the speed self tune procedure.
- Inertia c filter** 1<sup>st</sup> order low pass filter time constant. The filter reduces the noise value owed to the operation of the speed differentiation in the Inertia compensation block.

## 6.8 CURRENT REGULATION (CURRENT REGULAT)

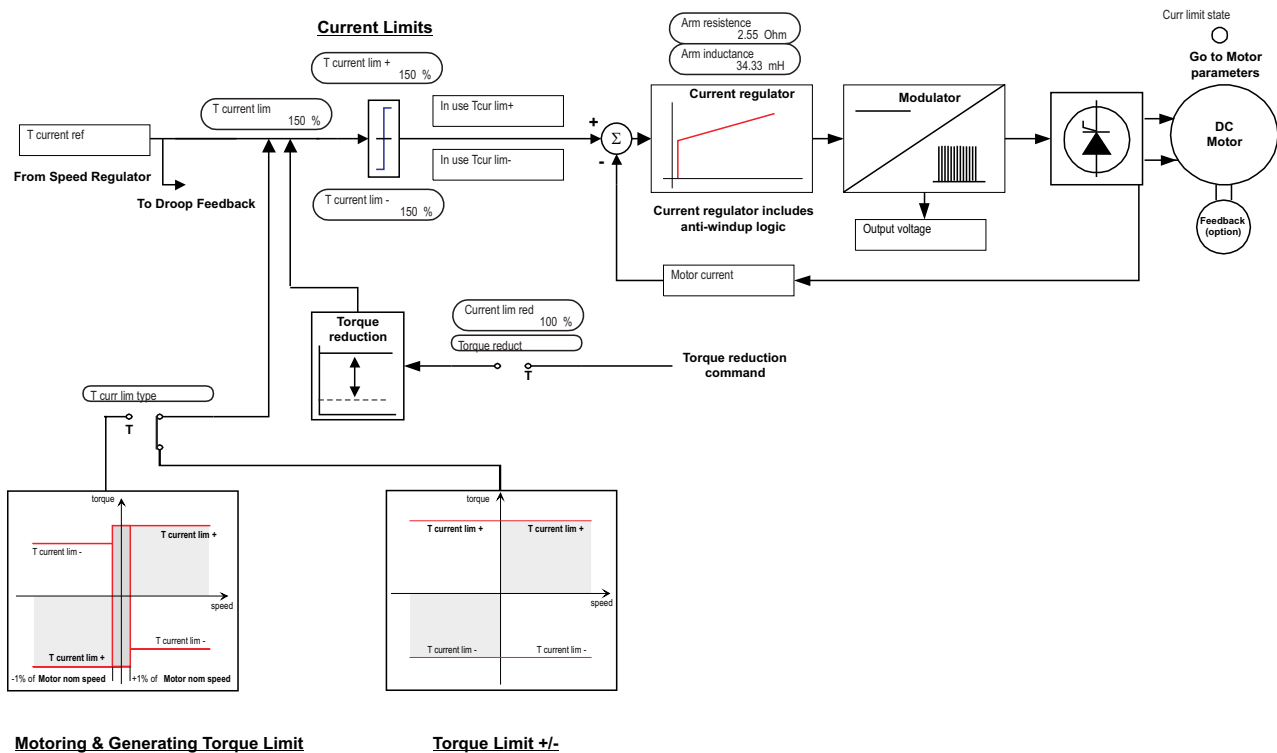

Figure 6.8.1: Torque current regulator

### CURRENT REGULAT

|        |                       |
|--------|-----------------------|
| [41]   | T current ref [%]     |
| [199]  | Motor current [%]     |
| [1430] | Mot cur threshld [%]  |
| [1431] | Mot cur th delay [ms] |
| [1520] | dI/dt delta time      |
| [453]  | Arm resistance [ ]    |
| [454]  | Arm inductance [mH]   |
| [587]  | E int [V]             |
| [452]  | R&L Search            |
| [353]  | Zero torque           |

| Parameter description        | No.        | Value |       |                  |                  | Standard Configuration |
|------------------------------|------------|-------|-------|------------------|------------------|------------------------|
|                              |            | min   | max   | Factory American | Factory European |                        |
| <b>T current ref [%]</b>     | 41         | -200  | +200  | -                | -                | **                     |
| <b>Motor current [%]</b>     | 199        | -250  | 250   | -                | -                | -                      |
| <b>Mot cur threshld [%]</b>  | 1430       | 0     | 200   | 100              | 100              |                        |
| <b>Mot cur th delay [ms]</b> | 1431       | 0     | 65535 | 1000             | 1000             |                        |
| <b>Arm resistance [ ]</b>    | 453        | S     | S     | 0.500            | 0.500            | -                      |
| <b>Arm inductance [mH]</b>   | 454        | S     | S     | 4.00             | 4.00             | -                      |
| <b>E int [V]</b>             | 587        | -80   | +80   | -                | -                | **                     |
| <b>R&amp;L Search</b>        | 452        | 0     | 1     | OFF              | OFF              | -                      |
| <b>Zero torque</b>           | 353        | 0     | 1     | Not active (1)   | Not active (1)   | *                      |
|                              | Active     |       |       |                  |                  |                        |
|                              | Not active |       |       |                  |                  |                        |

\* This function can be assigned to one of the programmable digital inputs.

\*\* This parameter can be assigned to a programmable analog output.

The user defines the full load current of the motor via the **Full load curr** (FLC) parameter in the CONFIGURATION menu. This is at the same time the output current of the inverter when **T current ref** = 10%.



- T current ref** Total current reference as a percentage of **Full load curr.** For this parameter the TPD32...4B... converters need a positive value. In this case the negative references are processed and correspond to a zero reference.
- Mot cur threshld** When the motor current exceeds the Full Load Current percentage threshold, this condition is signalled via a digital output.
- Mot cur th delay** The *Mot cur th delay* parameter can be used to set the delay after which the current within limit condition is signalled..
- dI/dt delta time** This parameter is used to change the time (and thus the ramp gradient) within which the value of **T current ref** (parameter 41) changes from 0 to 100%.

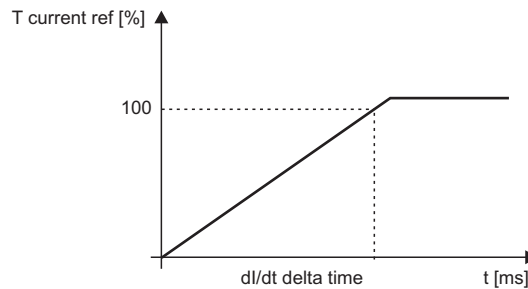

- Arm resistance** Motor armature resistance in  $\Omega$ . When self-tuning cycle is performed via **R&L Search** this parameter is set to the obtained value. Therefore, if necessary, it can be changed.
- Arm inductance** Motor armature inductance in mH. When self-tuning cycle is performed via **R&L Search** this parameter is set to the obtained value. Therefore, if necessary, it can be changed.

| Parameter                  | N.  | Value max            |                |
|----------------------------|-----|----------------------|----------------|
|                            |     | sizes 185 ... 1050 A | sizes > 1050 A |
| <b>Arm inductance [mH]</b> | 454 | 50 mH                | 30 mH          |

- E int** Auxiliary signal used to determine whether the current regulator is correctly tuned. Its value should be close to zero, but values dynamically changing between -40 and 40 are acceptable.  
The drive must have at least 30% load for this reading to be considered as a valid performance measurement (see chapter 5.3.5.1.1 for more detail setting) .
- R&L Search** Execution of self-tuning for the current regulator. The identified values for resistance and inductance armature are set to the **Arm resistance** and **Arm inductance** parameters.
- Zero torque** The parameter can be used to set the reference value for the armature current **T current ref** to zero so that the drive has no more torque.  
Not active (H) **T current ref** not set to zero  
Active (L) **T current ref** set to zero. The drive has no torque.

## 6.9 FLUX REGULATION

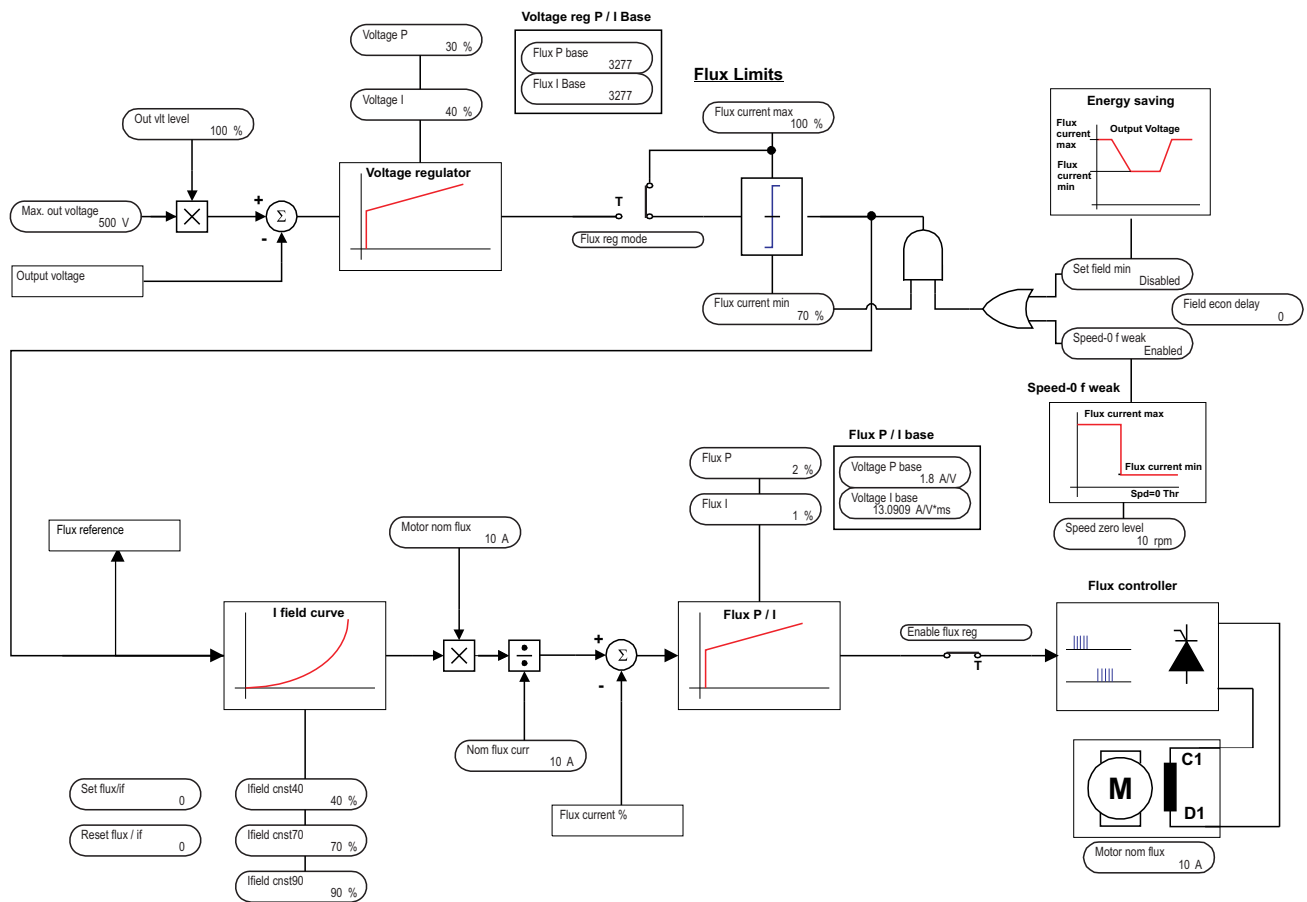

Figure 6.9.1: Motor control

### FLUX REGULATION

|       |                    |
|-------|--------------------|
| [497] | Enable flux reg    |
| [469] | Flux reg mode      |
| [498] | Enable flux weak   |
| [499] | Speed-0 f weak     |
| [500] | Flux reference [%] |
| [234] | Flux current %     |
| [921] | Out vlt level      |

### Flux \ if curve

|       |                    |
|-------|--------------------|
| [916] | I field cnst 40    |
| [917] | I field cnst 70    |
| [918] | I field cnst 90    |
| [919] | Set flux / if      |
| [920] | Reset flux / if    |
| [374] | Nom flux curr [A]  |
| [280] | Motor nom flux [A] |

| Parameter description   | No. | Value |       |                    |                    | Standard Configuration |
|---|-----|-------|-------|--------------------|--------------------|------------------------|
|   |     | min   | max   | Factory American   | Factory European   |                        |
| <b>Enable flux reg</b><br>ON / OFF  | 497 | 0     | 1     | Enabled            | Enabled            | *                      |
| <b>Flux reg mode</b><br>Constant current (0)<br>Voltage control (1)<br>External control (2) | 469 | 0     | 2     | Const. current (0) | Const. current (0) | -                      |
| <b>Enable flux weak</b><br>ON / OFF   | 498 | 0     | 1     | 1                  | 1                  | *                      |
| <b>Speed-0 f weak</b><br>ON / OFF   | 499 | 0     | 1     | 0                  | 0                  |                        |
| <b>Flux reference [%]</b>   | 500 | 0.0   | 100.0 | 0.0                | 0.0                | **                     |
| <b>Flux current [%]</b>   | 234 | 0.0   | 100.0 | -                  | -                  | **                     |
| <b>Out vlt level</b>  | 921 | 0.00  | 100.0 | 100.0              | 100.0              | **/**                  |
| <b>I field cnst 40</b>  | 916 | 0.0   | 100.0 | 40.0               | 40.0               |                        |
| <b>I field cnst 70</b>  | 917 | 0.0   | 100.0 | 70.0               | 70.0               |                        |
| <b>I field cnst 90</b>  | 918 | 0.0   | 100.0 | 90.0               | 90.0               |                        |
| <b>Set flux / if</b>  | 919 | 0     | 1     | 0                  | 0                  |                        |
| <b>Reset flux / if</b>  | 920 | 0     | 1     | 0                  | 0                  |                        |
| <b>Nom flux curr [A]</b>  | 374 | 0.5   | 70.0  | S                  | S                  |                        |
| <b>Motor nom flux</b>   | 280 | 0.00  | P374  | P374               | P374               |                        |

\* This function can be set on a programmable digital input.

\*\* This parameter can be set on a programmable analog output.

\*\*\* This parameter can be set on a programmable analog input.

**Enable flux reg**      Enabling of the field converter  
ON      Field converter Enabled  
OFF      Field converter Disabled. The field current is zero.

**Flux reg mode**      Operating mode of the field converter .  
Constant current      The motor field works with a constant current. The current value corresponds to the setting of the **Motor nom flux** parameter.  
If any curve via the **I field cnst** parameters will be defined, this value can be changed linearly, through **Motor nom flux** (percentage of nominal flux **Motor nom flux**) (see Flux /if curve paragraph 5.4.5)  
Voltage control      The drive works with a regulation combined with torque and constant power (armature and field regulation). Via the **Max out voltage** parameter in the CONFIGURATION menu, is set the max. armature voltage.  
When **Enable fbk bypass** (PAR 458) is enabled (default) the **Voltage control selection** is disabled.  
External control      The field is supplied through an external excitation (rectifier/field converter).

**Enable flux weak**      Command for **Voltage control**.  
ON      The field current corresponds to the value set via the **Flux current min** parameter.  
OFF      The field current is regulated on the basis of the functioning mode and on the drive working setpoint.

**Speed-0 f weak**      When this function is enabled, and the speed 0 threshold is reached, it will be produced the minimum field current set via **Flux current min**.  
Supposing that: **Start** = Low level and/or **Fast stop** = Low level  
Set as field economy:  
To avoid the overheating of motors which should not run or to avoid the presence of condensation in motor which work externally ( the field will be used as anti condensation heating).

ON Enabled function  
 OFF Disabled function

- Flux reference** Flux/current reference : the 100% corresponds to the **Motor nom flux** parameter. With the function Flux / if curve defined, this reference corresponds to the flux reference. With the function Flux / if curve not defined (default conditions), this reference corresponds to the field current reference.
- Flux curr (%)** Field current feedback, expressed as percentage of the **Motor nom flux** parameter.
- Out vlt level** Percentage of the maximum output voltage according to the **Max out voltage** parameter. This parameter allows the changing of the output voltage in “Voltage control” (FLUX REGULATION\Flux reg mode).
- I field cnst 40** Current value at 40% of flux (see Flux /if curve, paragraph 5.3.7)
- I field cnst 70** Current value at 70% of flux (see Flux /if curve, paragraph 5.3.7)
- I field cnst 90** Current value at 90% of flux (see Flux /if curve, paragraph 5.3.7)
- Set flux / if** Command for the setting of the flux curve according to the setting of **I field cnst 40-70-90** parameter. With the defined curve, the meaning of **Flux current max/Flux reference** indicates only the flux percentage according to the characteristic of this curve. As a consequence, the value of the field current will be determined by this characteristic (see Flux /if curve paragraph 5.3.7).
- Reset flux / if** Command for the reset of the flux curve set via command **Set flux / if**. With this command the **Motor nom flux** parameter will be again linearly changed through **Flux current max/Flux reference**. (see Flux /if curve paragraph 5.3.7)
- Nom flux curr** Rated current  $I_{FN}$  of the field regulator. In order to improve the behaviour of the regulation, the maximum field current can be reduced by setting the S14 dip-switches (on the regulation board, see table 2.4.3.2).

Example

Armature: 500 VDC                      Field: 230 VDC  
                   102 ADC                                      0.8 ADC  
 Drive type: TPD32-500/...-140... (Field current set to 14 Amps = default)

Set the dip switches S14 to decrease the field current from the drive supplied, as below:

| Switch ohms   | 168.5 Ohm | 333 Ohm | 182 Ohm | 36.4 Ohm | 845 Ohm | 1668 Ohm | Equivalent resistance |
|---------------|-----------|---------|---------|----------|---------|----------|-----------------------|
| Nom flux curr | S14-1     | S14-2   | S14-3   | S14-4    | S14-5   | S14-6    |                       |
| 1.0 A         | OFF       | OFF     | OFF     | OFF      | OFF     | ON       | 1668 Ohm              |

GD6111g

Set **Nom flux curr** parameter to 0.8.

**Motor nom flux** Rated field current  $I_{FN}$  of the connected motor.

## 6.10 REG PARAMETERS

| REG PARAMETERS |                       |                        |                          |
|----------------|-----------------------|------------------------|--------------------------|
|                | Percent values        | <b>Speed regulator</b> |                          |
|                |                       | [87]                   | Speed P [%]              |
|                |                       | [88]                   | Speed I [%]              |
|                |                       | [459]                  | Speed P bypass [%]       |
|                |                       | [460]                  | Speed I bypass [%]       |
|                |                       | <b>Flux regulator</b>  |                          |
|                |                       | [91]                   | Flux P [%]               |
|                |                       | [92]                   | Flux I [%]               |
|                |                       | <b>Voltage reg</b>     |                          |
|                |                       | [493]                  | Voltage P [%]            |
|                |                       | [494]                  | Voltage I [%]            |
|                |                       | Base values            | <b>Speed regulator</b>   |
|                | [93]                  |                        | Speed P base [A/rpm]     |
|                | [94]                  |                        | Speed I base [A/rpm.ms]  |
|                | <b>Flux regulator</b> |                        |                          |
|                | [97]                  |                        | Flux P base              |
|                | [98]                  |                        | Flux I base              |
|                | <b>Voltage reg</b>    |                        |                          |
|                | [495]                 |                        | Voltage P base [f%/V]    |
|                | [496]                 |                        | Voltage I base [f%/V.ms] |
| In use values  | [99]                  |                        | Speed P in use [%]       |
|                | [100]                 |                        | Speed I in use [%]       |

| Parameter description    | No. | Value  |        |                        |                        | Standard Configuration |
|--------------------------|-----|--------|--------|------------------------|------------------------|------------------------|
|                          |     | min    | max    | Factory American       | Factory European       |                        |
| Speed P [%]              | 87  | 0.00   | 100.00 | 10.00                  | 10.00                  | -                      |
| Speed I [%]              | 88  | 0.00   | 100.00 | 1.00                   | 1.00                   | -                      |
| Speed P bypass [%]       | 459 | 0.00   | 100.00 | 10.00                  | 10.00                  | -                      |
| Speed I bypass [%]       | 460 | 0.00   | 100.00 | 1.00                   | 1.00                   | -                      |
| Flux P [%]               | 91  | 0.00   | 100.00 | 2.00                   | 2.00                   | -                      |
| Flux I [%]               | 92  | 0.00   | 100.00 | 1.00                   | 1.00                   | -                      |
| Voltage P [%]            | 493 | 0.00   | 100.00 | 30.00                  | 30.00                  | -                      |
| Voltage I [%]            | 494 | 0.00   | 100.00 | 40.00                  | 40.00                  | -                      |
| Speed P base [A/rpm]     | 93  | 000.1  | S      | 0.3 x P93max<br>P93max | 0.3 x P93max<br>P93max | -                      |
| Speed I base [A/rpm.ms]  | 94  | 0.001  | S      | 0.3<br>P94max          | 0.3<br>P94max          | -                      |
| Flux P base              | 97  | 1      | 32767  | 3277                   | 3277                   | -                      |
| Flux I base              | 98  | 1      | 32767  | 3277                   | 3277                   | -                      |
| Voltage P base [f%/V]    | 495 | 0.0100 | S      | S                      | S                      | -                      |
| Voltage I base [f%/V.ms] | 496 | 0.01   | S      | S                      | S                      | -                      |
| Speed P in use [%]       | 99  | 0.00   | 100.00 | S                      | S                      | -                      |
| Speed I in use [%]       | 100 | 0.00   | 100.00 | S                      | S                      | -                      |

|                       |   |
|-----------------------|---|
| <b>Speed P</b>        | Proportional gain $K_p^*$ of the speed regulator expressed as a percentage of <b>Speed P base</b> .   |
| <b>Speed I</b>        | Integral gain $K_I^*$ of the speed regulator expressed as a percentage of <b>Speed I base</b> .   |
| <b>Speed P bypass</b> | Proportional gain $K_p^*$ of the speed regulator expressed as a percentage of <b>Speed P base</b> , when a feedback via encoder or tachometer is changed into a armature feedback ( <b>Enable fbk bypas</b> = Enabled). |
| <b>Speed I bypass</b> | Integral gain $K_I^*$ of the speed regulator expressed as a percentage of <b>Speed I base</b> , when a feedback via encoder or tachometer is changed into a armature feedback ( <b>Enable fbk bypas</b> = Enabled).     |
| <b>Fld reg P gain</b> | Proportional gain $K_p^*$ of the field current regulator expressed as percentage of <b>Flux P base</b> .  |
| <b>Fld reg I gain</b> | Integral gain $K_I^*$ of the field current regulator expressed as a percentage of <b>Flux I Base</b> .  |
| <b>Voltage P</b>      | Proportional gain $K_p^*$ of the field voltage regulator expressed as a percentage of <b>Voltage P base</b> .   |
| <b>Voltage I</b>      | Integral gain $K_I^*$ of the field voltage regulator expressed as a percentage of <b>Voltage I base</b> .   |
| <b>Speed P base</b>   | Proportional gain $K_{p0}$ of the speed regulator in A/rpm (base value)   |
| <b>Speed I base</b>   | Integral gain $K_{I0}$ of the speed regulator in A/rpm·ms (base value)  |
| <b>Flux P base</b>    | Proportional gain $K_{p0}$ of the field current regulator (base value)  |
| <b>Flux I Base</b>    | Integral gain $K_{I0}$ of the field current regulator in (base value)   |
| <b>Voltage P base</b> | Proportional gain $K_{p0}$ of the field voltage regulator in A / Vs (base value)  |
| <b>Voltage I base</b> | Integral coefficient $K_{I0}$ of the field voltage regulator in A / V · ms (base value)   |
| <b>Speed P in use</b> | Display of the active proportional coefficient of the speed regulator as a percentage of <b>Speed P base</b>  |
| <b>Speed I in use</b> | Display of the active derivative coefficient of the speed regulator as a percentage of <b>Speed I base</b>  |

The maximum value for the regulator parameters is defined by the base values. The settings possible depend on the size of the device.

The user can optimize the function of the regulator by changing the percentage values (values marked with \*).

The resulting gains for the regulator are calculated as follows:

$$K_p = K_{p0} \cdot K_p^* / 100 \% \quad K_I = K_{I0} \cdot K_I^* / 100 \%$$

Example of the speed regulator:

$$\begin{aligned} \text{Speed P base} &= 12 (= K_{p0}) & \text{Speed P} &= 70 \% (= K_p^*) \\ \text{Proportional gain } K_p &= 12 \cdot 70 \% / 100 \% = 8.4 \end{aligned}$$

The base values ... base are also the basis for setting the adaptive speed regulator.

When the adaptive speed regulator is enabled (**Enable spd adap** = Enabled), the **Speed P** and **Speed I** parameters have no effect. They still retain their value and are effective again when the speed regulator adaption is disabled.

The **Speed P in use** and **Speed I in use** parameters indicate the current gains for the speed regulator. This also applies when the speed regulator adaption is active.

## 6.11 CONFIGURATION

### 6.11.1 Operating mode selection

| CONFIGURATION |               |
|---------------|---------------|
| [252]         | Main commands |
| [253]         | Control mode  |

| Parameter description                                | No. | Value |     |                  |                  | Standard Configuration |
|--|-----|-------|-----|------------------|------------------|------------------------|
|  |     | min   | max | Factory American | Factory European |                        |
| <b>Main commands</b><br>Terminals (0)<br>Digital (1) | 252 | 0     | 1   | Term.(0)         | Term.(0)         | -                      |
| <b>Control mode</b><br>Local (0)<br>Bus (1)          | 253 | 0     | 1   | Local (0)        | Local (0)        | -                      |

**Main commands** These commands specify from where the **Enable drive**, **Start** and **Fast stop** commands are to be actuated.

**Terminals** The above commands are actuated exclusively via the terminal strip.

**Digital** Commands must be selected both via the terminal strip and via the digital channel (keypad or RS485 or bus, depending on the **Control mode**). If, for example, a stop of the drive is initiated by removing the **Start** command on terminal 13, both the voltage on terminal 13 and the command via the digital channel are necessary to restart the drive. This also applies to a removal of the **Fast stop** command. If the **Stop** is initiated via the digital channel, the digital command is sufficient to restart the drive.

The control method through terminal commands (Terminals) is selectable only when terminals 12 (Enable) and 13 (Start) are not supplied.

Carrying out the passage of the commands from Digital to Terminals with those terminals supplied, it will appear the message “**Change input**”, signalling the wrong action.

**Control mode** Defines whether the digital channel is the keypad/RS485 or a bus system (Option).

**Local** The digital channel is the keypad or the RS485 serial interface

**Bus** The digital channel is a bus system (Option)

The following tables show the operating modes possible.

| Parameters       |              | Actuation of:<br>Enable drive<br>Start<br>Fast stop | Control mode<br>selection     | Failure reset                                 | Save parameters        |
|------------------|--------------|---|-------------------------------|---|------------------------|
| Main<br>commands | Control mode |   |                               |   |                        |
| Terminals        | Local        | Terminals   | Keypad /RS485                 | Terminals of<br>Keypad                        | Keypad /RS485          |
| Digital          | Local        | Terminals and<br>keypad/RS485                       | Keypad /RS485                 | Terminals of<br>Keypad                        | Keypad /RS485          |
| Terminals        | Bus          | Terminals   | Keypad* /<br>RS485*<br>or Bus | Terminals or<br>keypad*<br>or Bus             | Keypad RS485<br>or Bus |
| Digital          | Bus          | Terminals and<br>Field Bus                          | Keypad* /<br>RS485*<br>or Bus | Terminals or<br>keypad* /<br>RS485*<br>or Bus | Keypad RS485<br>or Bus |

GD6125g

| Parameters       |              | Write Access Restrictions                                   |   |  |
|------------------|--------------|---|---|--|
| Main<br>commands | Control mode | Terminals   | Keypad / RS485  | Bus  |
| Terminals        | Local        | Access to<br>everything assigned<br>to programmable<br>I/Os | Access to all<br>parameters not<br>assigned to<br>programmable I/Os           | None   |
| Digital          | Local        | Access to<br>everything assigned<br>to programmable<br>I/Os | Access to all<br>parameters not<br>assigned to<br>programmable I/Os           | None   |
| Terminals        | Bus          | Access to<br>everything assigned<br>to programmable<br>I/Os | - read all<br>- save parameters<br>-reset failures*<br>- select Control mode* | Access to all<br>parameters not<br>assigned to<br>programmable I/Os                        |
| Digital          | Bus          | Access to<br>everything assigned<br>to programmable<br>I/Os | - read all<br>- save parameters<br>-reset failures*<br>- select Control mode* | Access to all<br>parameters not<br>data channel is not<br>assigned to<br>programmable I/Os |

GD6130g

\* Access via the keypad or the RS485 serial interface is protected in this configuration by **Password level 1**

**Note!** Write access from Bus through data channel is not affected by Control Mode selection.



### 6.11.2 Speed base value, Full load current

| CONFIGURATION |                       |
|---------------|-----------------------|
| [45]          | Speed base value [FF] |
| [179]         | Full load curr [A]    |
| [175]         | Max out voltage [V]   |

| Parameter description | No. | Value |       |                  |                  | Standard Configuration |
|-----------------------|-----|-------|-------|------------------|------------------|------------------------|
|                       |     | min   | max   | Factory American | Factory European |                        |
| Speed base value [FF] | 45  | 1     | 16383 | 1500             | 1500             | -                      |
| Full load curr [A]    | 179 | 0.1   | P465  | P465             | P465             | -                      |
| Max out voltage [V]   | 175 | 20    | 999   | 400              | 400              | -                      |

**Speed base value** The **Speed base value** is defined by the unit specified in the factor function. It is the reference value for all speed values (reference values, adaptive speed regulation.) given as a percentage, and corresponds to 100% of the speed. Changing this parameter is only possible when the drive is disabled (**Enable drive** = Disabled). The **Speed base value** does not define the maximum possible speed, which in some cases can be formed from the addition of several reference values. This is defined with **Speed max amount**.

**Full load curr** The **Full load curr** (FLC) parameter is defined in Amps. It corresponds to 100 % of the current limit. The settings for the current limit and the overload function are based on this active current value.

**Max out voltage** Max armature voltage supplied from the drive. When it has been set as **Flux reg mode** "Voltage control", **Max out voltage** corresponds to the crossover point. This parameter has an influence on the intervention threshold of the "Overvoltage" message.

### 6.11.3 Configuration of the OK relay (Terminals 35,36)

| CONFIGURATION |                |
|---------------|----------------|
| [412]         | Ok relay funct |

| Parameter description                                     | No. | Value |     |                  |                  | Standard Configuration |
|---|-----|-------|-----|------------------|------------------|------------------------|
|   |     | min   | max | Factory American | Factory European |                        |
| Ok relay funct<br>Drive healthy (0)<br>Ready to Start (1) | 412 | 0     | 1   | 0                | 0                | -                      |

**Ok relay func** This parameter defines the condition in which the relay contact will close.

Drive healthy The contact will close when the drive is supplied with voltage and when there are no failure alarms.

Ready to start The contact closes when the following conditions are fulfilled:

- The drive has a voltage supply
- There are no failure alarms present
- The drive is enabled with **Enable drive**.

## 6.11.4 To increase the resolution of current limits and references

### CONFIGURATION

|        |                |
|--------|----------------|
| [1521] | En TCurr HiRes |
|--------|----------------|

| Parameter description                              | No.  | Value |     |                  |                  | Standard Configuration |
|--|------|-------|-----|------------------|------------------|------------------------|
|  |      | min   | max | Factory American | Factory European |                        |
| <b>En TCurr HiRes</b><br>Disable (0)<br>Enable (1) | 1521 | 0     | 1   | 0                | 0                | -                      |

When the **En TCurr HiRes** parameter is enabled the resolution of the parameters in the table can be increased:

| Values with En TCurr HiRes <u>disabled</u> |     |     |      |     |            |            |     |
|--|-----|-----|------|-----|------------|------------|-----|
| Parameter                                  | N.  | UdM | Min  | Max | Default US | Default EU |     |
| <b>T current lim</b>                       | 7   | [%] | 0    | 200 | 150        | 100        | R/W |
| <b>T current lim +</b>                     | 8   | [%] | 0    | 200 | 150        | 100        | R/W |
| <b>T current lim -</b>                     | 9   | [%] | 0    | 200 | 150        | 100        | R/W |
| <b>In use Tcur lim+</b>                    | 10  | [%] | 0    | 200 | ---        | ---        | R   |
| <b>In use Tcur lim-</b>                    | 11  | [%] | 0    | 200 | ---        | ---        | R   |
| <b>T current ref 1</b>                     | 39  | [%] | -200 | 200 | 0          | 0          | R/W |
| <b>T current ref 2</b>                     | 40  | [%] | -200 | 200 | 0          | 0          | R/W |
| <b>Motor current</b>                       | 199 | [%] | -200 | 200 | ---        | ---        | R   |
| <b>F T curr</b>                            | 928 | [%] | -200 | 200 | ---        | ---        | R   |

| Values with En TCurr HiRes <u>enabled</u> |     |      |       |      |            |            |     |
|---|-----|------|-------|------|------------|------------|-----|
| Parameter                                 | N.  | UdM  | Min   | Max  | Default US | Default EU |     |
| <b>T current lim</b>                      | 7   | [--] | 0     | 2000 | 1500       | 1000       | R/W |
| <b>T current lim +</b>                    | 8   | [--] | 0     | 2000 | 1500       | 1000       | R/W |
| <b>T current lim -</b>                    | 9   | [--] | 0     | 2000 | 1500       | 1000       | R/W |
| <b>In use Tcur lim+</b>                   | 10  | [--] | 0     | 2000 | ---        | ---        | R   |
| <b>In use Tcur lim-</b>                   | 11  | [--] | 0     | 2000 | ---        | ---        | R   |
| <b>T current ref 1</b>                    | 39  | [--] | -2000 | 2000 | 0          | 0          | R/W |
| <b>T current ref 2</b>                    | 40  | [--] | -2000 | 2000 | 0          | 0          | R/W |
| <b>Motor current</b>                      | 199 | [--] | -2000 | 2000 | ---        | ---        | R   |
| <b>F T curr</b>                           | 928 | [--] | -2000 | 2000 | ---        | ---        | R   |

The maximum resolution for parameters relating to **Full load current** (IPA 179) is 1/1000.

If the function is disabled the maximum resolution remains at 1/100.

**Important note:** Each time the **En TCurr HiRes** selection changes the parameters shown in the table are automatically set to their default value.

## 6.11.5 Configuration of the speed feedback circuit

| CONFIGURATION |                  |                       |
|---------------|------------------|-----------------------|
|               | Speed fbk        |                       |
|               | [162]            | Motor max speed [rpm] |
|               | [414]            | Speed fbk sel         |
|               | [457]            | Enable fbk contr      |
|               | [458]            | Enable fbk bypas      |
|               | [456]            | Flux weak speed [%]   |
|               | [455]            | Speed fbk error [%]   |
|               | [562]            | Tacho scale           |
|               | [563]            | Speed offset          |
|               | [416]            | Encoder 1 pulses      |
|               | [169]            | Encoder 2 pulses      |
|               | [649]            | Refresh enc 1         |
|               | [652]            | Refresh enc 2         |
| [911]         | Enable ind store |                       |

| Parameter description   | No. | Value  |        |                  |                  | Standard Configuration |
|---|-----|--------|--------|------------------|------------------|------------------------|
|   |     | min    | max    | Factory American | Factory European |                        |
| <b>Motor max speed [rpm]</b>  | 162 | 0      | 6553   | 1500             | 1500             | -                      |
| <b>Speed fbk sel</b><br>Encoder 1 (0)<br>Encoder 2 (1)<br>Tacho (2)<br>Armature (3) | 414 | 0      | 3      | 1                | 1                | -                      |
| <b>Encoder 1 state</b><br>Encoder Fault (0)<br>Encoder ok (1)                       | 648 | 0      | 1      |                  |                  | -                      |
| <b>Enable fbk contr</b><br>Enabled (1)<br>Disabled (0)                              | 457 | 0      | 1      | Enabled (1)      | Enabled (1)      | -                      |
| <b>Enable fbk bypas</b><br>Enabled (1)<br>Disabled (0)                              | 458 | 0      | 1      | 0                | 0                | -                      |
| <b>Flux weak speed [%]</b>  | 456 | 0      | 100    | 100              | 100              | -                      |
| <b>Speed fbk error [%]</b>  | 455 | 0      | 100    | 22               | 22               | -                      |
| <b>Tacho scale</b>  | 562 | 0.90   | 3.00   | 1.00             | 1.00             | -                      |
| <b>Speed offset</b>   | 563 | -20.00 | +20.00 | 0.00             | 0.00             | -                      |
| <b>Encoder 1 pulses</b>   | 416 | 600    | 9999   | 1024             | 1024             | -                      |
| <b>Encoder 2 pulses</b>   | 169 | 150    | 9999   | 1000             | 1000             | -                      |
| <b>Refresh enc 1</b><br>Enabled (1)<br>Disabled (0)                                 | 649 | 0      | 1      | Disabled (0)     | Disabled (0)     | -                      |
| <b>Encoder 2 state</b><br>Encoder Fault (0)<br>Encoder ok (1)                       | 651 | 0      | 1      |                  |                  | -                      |
| <b>Refresh enc 2</b><br>Enabled (1)<br>Disabled (0)                                 | 652 | 0      | 1      | Disabled (0)     | Disabled (0)     | -                      |
| <b>Enable ind store</b><br>Enabled (1)<br>Disabled (0)                              | 911 | 0      | 1      | Disabled (0)     | Disabled (0)     | -                      |
| <b>Ind store ctrl</b>   | 912 | 0      | 65535  | 0                | 0                | -                      |
| <b>Index storing</b>  | 913 | 0      | +232-1 | 0                | 0                | -                      |

### Note!

The encoder or the tachometer are necessary for the regulation mode Flux reg mode “Voltage control” and “External control”. The features of the electrical data of the encoder and the tachometer are defined in sections 2.7.2, “Encoder / Tachometer”, and 2.4.5, “Accuracy”.

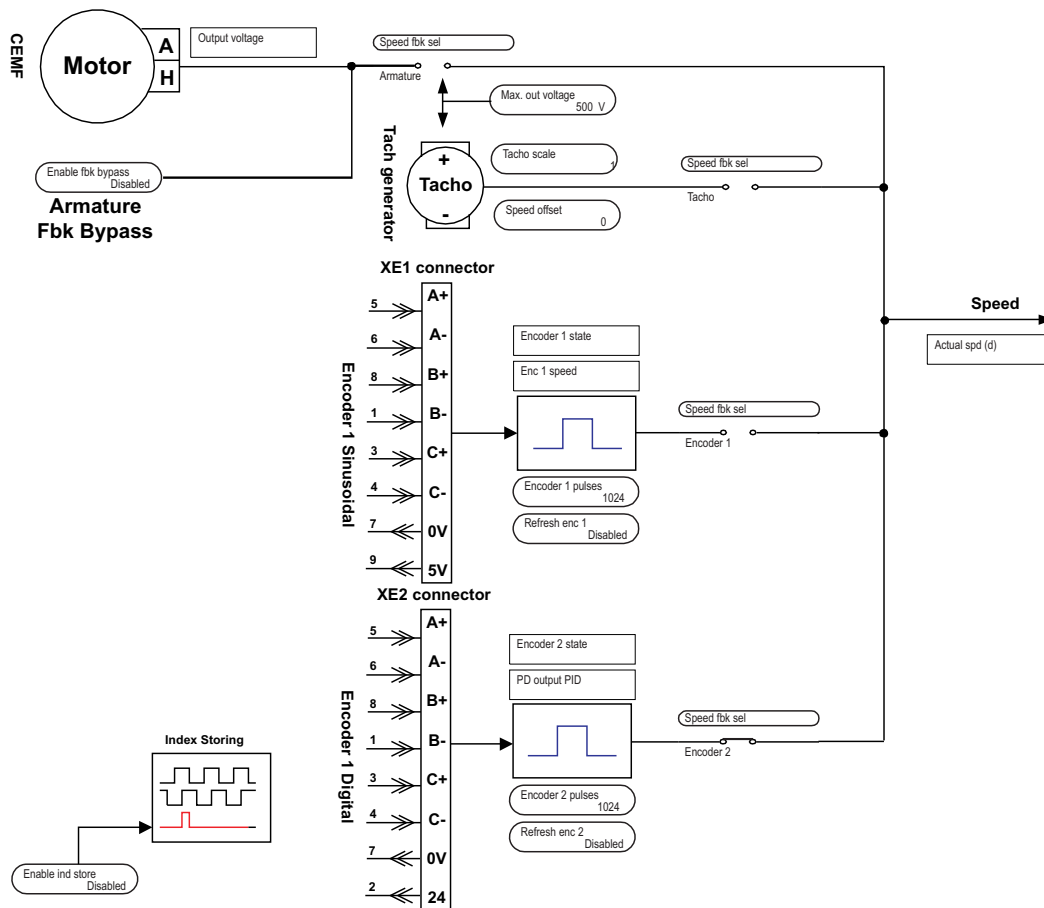

Figure 6.11.5.1: Speed feedback

### Motor max speed

Max motor speed. It is used to convert tach and armature feedback values in rpm. In case of speed feedback from tachogenerator it is used to convert the tach voltage in an rpm value. In case of armature voltage feedback **Max out voltage** parameter is considered equivalent to **Motor max speed**.

### Speed fbk sel

Select which feedback has to be used.

|           |   |
|-----------|---|
| Encoder 1 | The sinusoidal encoder connected th the XE1 connector is used.                                |
| Encoder 2 | The digital encoder connected to the XE2 connector is used (standard).                        |
| Tacho     | The analog tachogenerator connected to the terminals + and - is used.                         |
| Armature  | The internal measurement of the armature voltage is used. No external connection is required. |

### Enable fbk contr

Enable of the control for the speed feedback.

|          |                  |
|----------|------------------|
| Enabled  | Enabled control  |
| Disabled | Disabled control |

This function controls the speed feedback, where a comparison between the armature voltage and the speed value read by the encoder or by the tachometer is made. When an excursion higher of the value set via **Speed fbk error** is signaled, the failure message “Speed fbk loss” appears. This function is automatically disabled when the armature feedback has been selected. (**Speed fbk sel** = Armature).

### Enable fbk bypas

Enable of the automatic change into an armature feedback when the failure message “Speed fbk loss” is caused by a lack of the encoder or tachometer feedback.

|          |                           |
|----------|---------------------------|
| Enabled  | Enabled automatic change  |
| Disabled | Disabled automatic change |

After an automatic change into an armature feedback, the speed regulator works with the **Speed P bypass** and **Speed I bypass** parameters of the REG PARAMETERS/Percent values/Speed regulator menu. The failure message “Speed fbk loss” with an enable must be configured so that it is set as “Activity = Warning”. Possible working only with constant field current.

|                         |  |
|-------------------------|--|
| <b>Flux weak speed</b>  | Speed value as a percentage of <b>Motor max speed</b> , when the Voltage control phase starts. The <b>Flux weak speed</b> parameter, when the speed feedback control is enabled (Enable fbk contr = Enabled), is used to underline the fact that during the Voltage control phase the armature voltage and the feedback signal are not proportional. If the drive works with a constant torque on the whole regulation range ( <b>Flux reg mode</b> = Constant Current), it is necessary to insert the factory set 100% value. |
| <b>Speed fbk error</b>  | Max. allowed error expressed as a percentage of the max. output voltage ( <b>Max out voltage</b> ). By means of Max out Voltage, Flux weak speed and Motor nominal speed a relation between motor speed and armature voltage is obtained. If a difference higher than Speed fbk error occurs a Speed fbk loss failure occurs.  |
| <b>Tacho scale</b>      | Fine scaling of the speed feedback using a tachometer analog generator ( <b>Speed fbk sel</b> = Tacho). It is a multiplier of the read tach voltage.<br>For example:<br>Analog tach = 60V/1000 rpm, motor top running speed 3000 rpm.<br>Maximum tach volts = (60V/1000 rpm*3000rpm)= 180 VDC.<br>- Set dip-switch S4 for 181.6V (see table 4.4.3)<br>- Set the tacho scale parameter = 181.6V / 180V = 1.01<br>- Fine adjust the value of Tacho scale if the 180 VDC tach voltage is not perfectly reached.                   |
| <b>Speed offset</b>     | Offset scaling of the feedback circuit.  |
| <b>Encoder 1 pulses</b> | Number of pulses per revolution of the sinusoidal encoder connected to the XE1 connector.  |
| <b>Encoder 2 pulses</b> | Number of pulses per revolution of the digital encoder connected to the XE2 connector. The Encoder 2 pulses and Motor max speed shall be inside the allowed area shown in figure 6.11.5.2  |

*Figure 6.11.5.2: Allowed area for Encoder 2 pulses and Motor max speed*

|                      |   |
|----------------------|---|
| <b>Refresh enc 1</b> | Enable the monitoring of the encoder 1(connector XE1) connection status, in order to detect a speed feedback loss alarm.<br>When an alarm is detect, the keypad will shown „Speed fbk loss“. <b>Encoder 1 state</b> provides the indication of encoder 1 connection status. The parameter can be programmed on a digital output. This function is activate setting <b>Enable fbk contr</b> = Enabled. |
|----------------------|---|

**Refresh enc 2** Enable the monitoring of the encoder 2 (connector XE2) connection status, in order to detect a speed feedback loss alarm.

When an alarm is detect, the keypad will shown „Speed fbk loss“. **Encoder 2 state** provides the indication of encoder 2 connection status. The parameter can be programmed on a digital output. This function is activate setting **Enable fbk contr** = Enabled.

**Encoder 1 state** Provides the indication of the encoder 1 (connector XE1) connection status. The parameter can be programmed on a digital output.

**Encoder 2 state** Provides the indication of the encoder 2 (connector XE2) connection status. The parameter can be programmed on a digital output.

**Note!** The **Tacho scale** and **Speed offset** parameters are used for a fine scaling of the speed feedback circuit. When the factory set parameters are loaded (**Load default**) these two parameters do not undergo any change, so that a new scaling is not necessary!

*Following parameters allows to determine the machine absolute zero and perform a positioning control by using the APC200 option card:*

**Enable ind store** This parameter enables the reading of the encoder index and qualifying signal that could be used in a system for implementation of position control.

Enabled This setting enables the reading of the encoder index.

Disabled This setting disables the reading of the encoder index

**Ind store ctrl** Control register for the encoder index and qualifying signal (\*).

**Index storing** Status register and function data.

(\*) Index qualifier signal is not supported by regulation card R-TPD3G revision f (product configuration “D1”) and lower

**Ind store ctrl parameter [92]**

| No. bit | Name                  | Description   | Access (Read/Write) | Default |
|---------|-----------------------|---|---------------------|---------|
| 0-1     | -                     | Not used  | -                   | -       |
| 2       | <b>POLNLT</b>         | It indicates the encoder index edge polarity:<br>0 = rising edge<br>1 = falling edge  | R/W                 | 0       |
| 3       | -                     | Not used  | -                   | -       |
| 4-5     | <b>ENNQUAL</b>        | It indicates the qualifier level that activates the encoder index reading:<br>0 = Switched off<br>1 = Switched off<br>2 = Through signal = 0<br>3 = Through signal = 1  | W                   | 0       |
| 6       | <b>Target Enc Num</b> | It points out for which encoder the values of this parameter are reported:<br>0 = operations requested on the Encoder 1<br>1 = operations requested on the Encoder 2  | R/W                 | 0       |
| 7       | -                     | Not used  | -                   | -       |
| 8-9     | <b>ENNLT</b>          | Control function of the encoder index reading:<br>0 = Switched off, function disabled<br>1 = Once, enables the reading of the first index signal edge only<br>2 = Continuous, enables the reading of the index signal | R/W<br>.<br>.<br>.  | 0       |

## Index storing parameter [13]

| No. bit      | Name                  | Description  | Access (Read/Write) | Default |
|--------------|-----------------------|--|---------------------|---------|
| <b>0</b>     | <b>Source Enc Num</b> | It indicates to which encoder the values in this register are referred to:<br>0 = register data are referred to the Encoder 1<br>1 = register data are referred to the Encoder 2 | R                   | 0       |
| <b>1</b>     | <b>MP_IN</b>          | Actual Qualifier level value:<br>0 = qualifier input level is low<br>1 = qualifier input level is high   | R                   | 0       |
| <b>2-3</b>   | <b>STATNLT</b>        | Status of the acquisition function:<br>0 = Switched off<br>1 = Once, storing is not executed yet<br>2 = Once, storing is already executed<br>3 = Continuous                      | R                   | 0       |
| <b>16-31</b> | <b>CNTNLT</b>         | Position counter value corresponding to the index. 0 = Switched off<br>Value is only valid when STANLT is equal to 2 or 3  | R                   | 0       |

## 6.11.6 "Standard / American" selection, Software Version

| CONFIGURATION |            |
|---------------|------------|
|               | Drive type |
|               | [465]      |
|               | [201]      |
|               | [464]      |
|               | [331]      |

| Parameter description        | No. | Value |     |                  |                  | Standard Configuration |
|------------------------------|-----|-------|-----|------------------|------------------|------------------------|
|                              |     | min   | max | Factory American | Factory European |                        |
| Drive size [A]               | 465 | 0     | S   | S                | S                | -                      |
| 2B + E                       | 201 | 0     | 1   | 0                | 0                | -                      |
| ON (Off) (0)<br>OFF (On) (1) |     |       |     |                  |                  |                        |
| Size selection               | 464 | 0     | 1   | 1                | 0                | -                      |
| Standard (0)<br>American (1) |     |       |     |                  |                  |                        |
| Software version             | 331 |       |     |                  |                  | -                      |
| Drive type                   | 300 | 10    | 11  | S                | S                | -                      |
| TPD32-...-2B<br>TPD32-...-4B |     |       |     |                  |                  |                        |

**Drive size** Display of the converter armature current in ampere (it is codified by the SW15 Switch placed on the R-TPD32 regulation card). The stated value depends on the setting of the **Size selection** parameter.

**2B + E** Selection of the 2B + external excitation configuration. Only for 2B converters. The function allows the drive to work with an external 4 quadrant field controller. When the parameter is On the Ramp / Speed / T current references and Speed measurement have the same behaviour of the 4B drive.

**Size selection** With the "Standard" selection the converter produces rated current in a continuative way in the preset ambient conditions without overload (for overload see 6.14.5). With "America" selection the rated current is defined considering an overload of 1.5 times for 60 seconds. This causes a reduction of the converter rated current (continuative current) for the same type of drive. See section 4.4, R-TPD32 Regulation card.

Standard The converter produces rated current in a continuative way. It is stated as **Drive size**. No overload functions are set.

American The rated current (produced continuously) will be reduced to the value stated in the mentioned table and indicated in **Full load current** and **Drive size** parameters.

Automatically, the overload function (FUNCTION\Overload control), is set to the following:

|                                |                                     |
|--------------------------------|-------------------------------------|
| <b>Enable overload</b> = ON    | <b>Overload mode</b> = I2t motor    |
| <b>Overload time</b> = 60s     | <b>Full load current</b> = American |
| <b>Pause time</b> = 540s       | <b>T current lim</b> = 150%         |
| <b>Overload current</b> = 150% | <b>T current lim+</b> = 150%        |
| <b>Base current</b> = 100%     | <b>T current lim -</b> = 150%       |

If the size "American" is selected, the parameter **Overcurrent thr** [584] will be set at 160%

**Note!** If the converter is reconfigured as "Standard", these parameters and the continuous current limit take the values corresponding to the previous configuration (overload disabled) and the parameter **Overcurrent thr** [584] returns to 110%.

**Software version** Display of the software version number active in the converter.

**Drive type** Display of the drive type: 2B or 4B.



### 6.11.7 Dimension factor, Face value factor

| CONFIGURATION |                        |                 |
|---------------|------------------------|-----------------|
|               | <b>Dimension fact</b>  |                 |
|               | [50]                   | Dim factor num  |
|               | [51]                   | Dim factor den  |
|               | [52]                   | Dim factor text |
|               | <b>Face value fact</b> |                 |
|               | [54]                   | Face value num  |
| [53]          | Face value den         |                 |

The factor function consists of two factors - the dimension factor and the face value factor. Both factors are defined as fractions. The dimension factor is used to specify the drive speed in a dimension related to the machine concerned, e.g. kg/h or m/min. The face value factor is used to increase the resolution.

See the calculation examples given below.

| Parameter description  | No. | Value |         |                  |                  | Standard Configuration |
|------------------------|-----|-------|---------|------------------|------------------|------------------------|
|                        |     | min   | max     | Factory American | Factory European |                        |
| <b>Dim factor num</b>  | 50  | 1     | 65535   | 1                | 1                | -                      |
| <b>Dim factor den</b>  | 51  | 1     | +231 -1 | 1                | 1                | -                      |
| <b>Dim factor text</b> | 52  |       |         | rpm              | rpm              | -                      |
| <b>Face value num</b>  | 54  | 1     | +32767  | 1                | 1                | -                      |
| <b>Face value den</b>  | 53  | 1     | +32767  | 1                | 1                | -                      |

**Dim factor num** Numerator of the dimension factor

**Dim factor den** Denominator of the dimension factor

**Dim factor text** Unit of the dimension factor (5 characters). This text is shown in the keypad display for reference value entry. Possible characters: /%&+,-.0...9:<=>?A...Z[]a...z

**Face value num** Numerator of the face value factor

**Face value den** Denominator of the face value factor

The reference value given multiplied with the dimension factor and the face value factor defines the motor speed in rpm

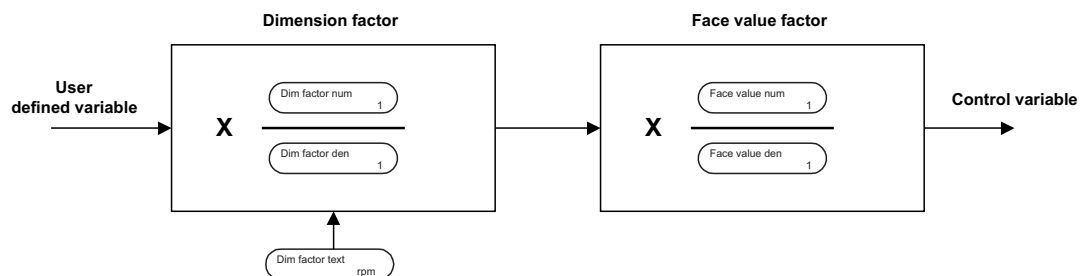

Figure 6.11.7.1: Calculation using dimension and face value factors

### Example 1 of the calculation of the dimension factor

The drive speed is given in m/s. The conversion ratio is 0.01 m per revolution of the motor (Note: face value factor = 1).

The dimension factor is calculated from

$$\text{Dimension factor} = \frac{\text{output (rpm)}}{\text{input (here: m/s)}} \quad \text{for01}$$

0.01 m corresponds to 1 revolution of the motor shaft

0.01 m/min corresponds to 1/min

0.01 m/60s corresponds to 1/min

$$\text{Dimension factor} = \frac{1}{\text{min}} \cdot \frac{60 \text{ s}}{0.01 \text{ m}} = \frac{6000}{1} \cdot \frac{1}{\text{min}} \cdot \frac{\text{s}}{\text{m}} \quad \text{for02}$$

When calculating the dimension factor, units should not be shortened (1 min is not shortened as 60 s)

**Dim factor num**        6000  
**Dim factor den**        1  
**Dim factor text**        m/s

### Example 2 of the calculation of the dimension factor

The reference values for a bottling plant are given in bottles per minute. One revolution of the drive corresponds to the filling of 0.75 bottles. This corresponds to a dimension factor of 4/3. The speed limitation and the ramp function are also given in bottles per minute

$$\text{Dimension factor} = \frac{\text{output (rpm)}}{\text{input (here: bottles / min)}} \quad \text{for03}$$

3/4 of a bottle corresponds to 1 revolution of the motor shaft

$$\text{Dimension factor} = \frac{1}{\text{min}} \cdot \frac{4 \text{ min}}{3 \text{ bottles}} = \frac{4}{3} \cdot \frac{1}{\text{min}} \cdot \frac{\text{min}}{\text{bottles}} \quad \text{for04}$$

Units should not be shortened when calculating the dimension factor.

**Dim factor num**        4  
**Dim factor den**        3  
**Dim factor text**        F/min (bottles per minute)

### Example of the face value factor

Normally the reference value has a resolution of 1 rpm. In order to exploit the available resolution, the face value factor is used.

The motor speed range required is, for example, 0...1500 rpm. A more accurate resolution (i.e. 1/4 revolution) can be obtained by setting the face value factor to 1/4.

The value 4 000 is entered, for example, in order to select 1000 rpm. This is then multiplied with the face value factor to give the value 1000 rpm.

**Face value num**        1  
**Face value den**        4

## 6.11.8 Programmable alarms

| CONFIGURATION |                         |                            |
|---------------|-------------------------|----------------------------|
|               | <b>Prog alarms</b>      |                            |
|               | <b>Failure supply</b>   |                            |
|               |                         | [194] Latch                |
|               |                         | [195] Ok relay open        |
|               | <b>Undervoltage</b>     |                            |
|               |                         | [481] Undervolt thr [V]    |
|               |                         | [357] Latch                |
|               |                         | [358] Ok relay open        |
|               |                         | [470] Hold off time [ms]   |
|               |                         | [359] Restart time [ms]    |
|               | <b>Overvoltage</b>      |                            |
|               |                         | [203] Activity             |
|               |                         | [361] Latch                |
|               |                         | [362] Ok relay open        |
|               |                         | [482] Hold off time [ms]   |
|               |                         | [483] Restart time [ms]    |
|               | <b>Overspeed</b>        |                            |
|               |                         | [1426] Overspeed thr [rpm] |
|               |                         | [1422] Activity            |
|               |                         | [1421] Latch               |
|               |                         | [1423] Ok relay open       |
|               |                         | [1424] Hold off time [ms]  |
|               |                         | [1425] Restart time [ms]   |
|               | <b>Heatsink</b>         |                            |
|               |                         | [368] Activity             |
|               |                         | [370] Ok relay open        |
|               | <b>Overtemp motor</b>   |                            |
|               |                         | [365] Activity             |
|               |                         | [367] Ok relay open        |
|               | <b>External fault</b>   |                            |
|               |                         | [354] Activity             |
|               |                         | [355] Latch                |
|               |                         | [356] Ok relay open        |
|               |                         | [502] Hold off time [ms]   |
|               |                         | [501] Restart time [ms]    |
|               | <b>Brake fault</b>      |                            |
|               |                         | [1296] Activity            |
|               |                         | [1297] Ok relay open       |
|               | <b>Motor I2t ovrlld</b> |                            |
|               |                         | [1419] Activity            |
|               |                         | [1442] Latch               |
|               |                         | [1420] Ok relay open       |
|               | <b>Drive I2t ovrlld</b> |                            |
|               |                         | [1441] Ok relay open       |

| Overcurrent     |                      |
|-----------------|----------------------|
| [584]           | Overcurrent thr [%]  |
| [212]           | Activity             |
| [363]           | Latch                |
| [364]           | Ok relay open        |
| [586]           | Hold off time [ms]   |
| [585]           | Restart time [ms]    |
| Field loss      |                      |
| [473]           | Activity             |
| [471]           | Latch                |
| [472]           | Ok relay open        |
| [475]           | Hold off time [ms]   |
| [474]           | Restart time [ms]    |
| Delta frequency |                      |
| [1437]          | Delta freq thres [%] |
| [1432]          | Activity             |
| [1433]          | Latch                |
| [1434]          | Ok relay open        |
| [1435]          | Hold off time [ms]   |
| [1436]          | Restart time [ms]    |
| Speed fbk loss  |                      |
| [478]           | Activity             |
| [477]           | Ok relay open        |
| [480]           | Hold off time [ms]   |
| Opt2 failure    |                      |
| [639]           | Activity             |
| [640]           | Ok relay open        |
| Bus loss        |                      |
| [634]           | Activity             |
| [633]           | Latch                |
| [635]           | Ok relay open        |
| [636]           | Hold off time [ms]   |
| [637]           | Restart time [ms]    |
| Hw opt1 failure |                      |
| [386]           | Activity             |
| [387]           | Ok relay open        |
| Enable seq err  |                      |
| [728]           | Activity             |
| [729]           | Latch                |
| [730]           | Ok relay open        |

The converters of the TPD32 series contain extensive monitoring functions. The effect of possible alarms on the behaviour of the drive are defined in the PROG ALARMS submenu:

- Saving of alarm status
- How the drive is to react to the alarm
- Indication via the relay between terminal 35 and 36 (central alarm). The switch conditions for the relay can be defined with the **Ok relay** func parameter in the CONFIGURATION menu.
- Automatic restart
- Failure reset

For some alarms, the behaviour of the drive can be configured separately. All alarms can also be assigned to a freely programmable digital output.

| Alarm            | N. | Factory       |                        |                  |                       |                      | Standard      |
|------------------|----|---------------|------------------------|------------------|-----------------------|----------------------|---------------|
|                  |    | Activity      | Latch                  | Open<br>OK relay | Hold off<br>time [ms] | Restart<br>time [ms] |               |
| Failure Supply   |    | Disable drive | ON                     | ON               | -                     | -                    | -             |
| Undervoltage     |    | Disable drive | ON                     | ON               | 0                     | 1000                 | Dig. Outp. 7* |
| Oversvoltage     |    | Ignore        | ON                     | ON               | 0                     | 0                    | Dig. Outp. 6* |
| Overspeed        |    | Ignore        | ON                     | ON               | 0                     | 0                    |               |
| Heatsink         |    | Disable drive | -                      | ON               | -                     | -                    | *             |
| Overtemp motor   |    | Disable drive | -                      | ON               | -                     | -                    | *             |
| External fault   |    | Disable drive | ON                     | ON               | 0                     | 0                    | *             |
| Brake fault      |    | Disable drive | -                      | ON               | -                     | -                    | -             |
| Motor I2t ovrlid |    | Disable drive | ON                     | ON               | -                     | -                    | -             |
| Drive I2t ovrlid |    | Disable drive | ON<br>not programmable | ON               | -                     | -                    | -             |
| Overcurrent      |    | Ignore        | ON                     | ON               | 0                     | 0                    | Dig. Outp. 8* |
| Field loss       |    | Disable drive | ON                     | ON               | 0                     | 0                    | *             |
| Delta frequency  |    | Ignore        | ON                     | ON               | 0                     | 0                    |               |
| Speed fbk loss   |    | Disable drive | -                      | ON               | 8                     | -                    | *             |
| Opt 2 failure    |    | Disable drive | ON                     | ON               | -                     | -                    | *             |
| Bus loss         |    | Disable drive | ON                     | ON               | 0                     | 0                    | *             |
| Hw Opt 1 failure |    | Disable drive | -                      | ON               | -                     | -                    | *             |
| Enable seq err   |    | Disable drive | ON                     | ON               | -                     | -                    |               |

GD6160g

\* This function can be assigned to one of the programmable digital outputs.

If the serial interface or a bus system is used, the alarms can be evaluated via the **Malfunction Code** parameter. The parameters required to configure the alarm are shown in Table in Section 10 of the manual.

|   |               |  |
|---|---------------|--|
| <b>Activity</b>   | Warning       | The alarm does not cause reaction of the drive. A warning message can be output via a digital output. When the drive is disabled, it will not restart until the failure has been canceled. |
|   | Disable drive | The alarm causes the immediate disabling of the converter. The motor runs to an uncontrolled stop.   |
|   | Quick stop    | When the alarm occurs, the drive stops according to the ramp set in the RAMP / QUICK STOP menu. The converter is then disabled.  |
|   | Normal stop   | When the alarm occurs, the drive stops according to the ramp set. The converter is then disabled.  |
|   | Curr lim stop | When the alarm occurs, the converter brakes with the maximum possible current. The converter is then disabled when stopped.  |
|   | Ignore        | No reaction is present. A warning message can be output via a digital output.  |
| Not all alarms can initiate a controlled stop of the drive. The possibility of setting the particular "Activity" for individual alarms is described in the table below. |               |  |

|                      |     |  |
|----------------------|-----|--|
| <b>Latch</b>         | ON  | The alarm is stored. The programmed actions (e.g. opening the OK relay) are enabled. This status is kept latched even if the fault condition is restored. A Reset command is required before a restart.    |
|                      | OFF | In case of alarm, the drive is disabled and the programmed functions are enabled. The alarm is not latched. When the failure is removed, the alarm is automatically reset and the device tries restarting. |
| <b>Ok relay open</b> | ON  | An alarm causes the opening of the potential isolated contact between terminals 35 and 36.   |
|                      | OFF | The alarm does not cause the opening of the potential free contact of the OK reay.   |

| Alarm            | Ignore | Warning | Disable drive | Quick stop | Normal stop | Curr lim stop |
|------------------|--------|---------|---------------|------------|-------------|---------------|
| Failure Supply   | -      | -       | X             | -          | -           | -             |
| Undervoltage     | -      | -       | X             | -          | -           | -             |
| Overvoltage      | X      | X       | X             | -          | -           | -             |
| Overspeed        | X      | X       | X             | X          | X           | X             |
| Heatsink         | -      | X       | X             | X          | X           | X             |
| Overtemp motor   | X      | X       | X             | X          | X           | X             |
| External fault   | -      | X       | X             | X          | X           | X             |
| Brake fault      | X      | X       | X             | X          | X           | X             |
| Motor I2t ovrlld | X      | X       | X             | -          | -           | -             |
| Drive I2t ovrlld | -      | -       | X             | -          | -           | -             |
| Overcurrent      | X      | X       | X             | -          | -           | -             |
| Field loss       | X      | X       | X             | -          | -           | -             |
| Delta frequency  | X      | X       | X             | -          | -           | -             |
| Speed fbk loss   | -      | X       | X             | -          | -           | -             |
| Opt 2 failure    | -      | -       | X             | X          | X           | X             |
| Bus loss         | X      | X       | X             | X          | X           | X             |
| Hw Opt 1 failure | -      | X       | X             | X          | X           | X             |
| Enable seq err   | X      | -       | X             | -          | -           | -             |

GD6165g

**Hold off time** Delay time between the alarm condition detection and the alarm activation. If an alarm condition occurs the alarm stay OFF for the **Hold off time**. When this time is elapsed and the alarm is still present, the alarm activates.

**Restart time** If **Latch=Off** and the alarm condition persists even after the time defined via **Restart time**, the alarm is stored and no restart is possible (**Latch=OFF**).

**Note!** In Terminal mode to reset the fault the terminals enable and start must be at zero voltage. The occurrence of a failure is indicated in the display of the keypad. If “Latch”=ON is selected, a Reset command is necessary. This can be carried out, for example, by pressing the CANCEL key on the keypad. If a second error occurs before the first one was reset, the text “Multiple failures” will appear in the display. In this case, a reset is only possible via **Failure reset** parameter in the SPEC FUNCTIONS menu. The reset can be obtained by pressing the ENT key with a disabled inverter.

**Failure supply** Failure on the supply voltage.  
It indicates a failure on the internal voltage of the regulation circuit. The message “Failure supply” occurs if an enabled converter has no voltage on the U2 and V2 terminals. If it is of a short duration and restored, a possible digital output prepared for the message is set to a Low condition. A normal reset can be carried out.

**Undervoltage** AC Input undervoltage.  
In case of an AC Input voltage when the regulation is enabled (**Enable drive = Enabled**) the message **Undervoltage** appears. The converter is immediately disabled. To this purpose an intervention threshold is preset via the **Undervolt thr** parameter.  
If the alarm is not saved (Latch=OFF), the drive tries to start automatically after the voltage has been restored. Using the ramp, when the voltage is restored, if the function Auto capture is active, the ramp output is set to the value corresponding to the current motor speed. This avoids speed jumps.

**Overvoltage** Armature overvoltage. Ther message appears when the armature voltage exceeds the value set via **Max out voltage** by 20%.  
If the alarm is not saved (Latch = OFF), the drive will attempt to restart automatically after the voltage has been restored.  
Using the ramp, when the voltage is restored, if the function Auto capture is active, the ramp output is set to the value corresponding to the current motor speed. This avoids speed jumps.

**Overspeed** This alarm condition is signalled if the speed limit set in the *Overspeed thr* parameter is exceeded.

|                         |   |
|-------------------------|---|
| <b>Heatsink</b>         | <p>Heatsink temperature of the converter is too high</p> <p>This alarm always initiates the disconnection of the device 10 seconds after the failure has been detected (Latch=ON).</p> <p>An external controller (PLC,etc.) can read the alarm via programmable output, RS485 or Bus and it can execute a controlled stop within a 10 second delay.</p>   |
| <b>Overtemp motor</b>   | Motor temperature (connection for thermistor:terminals 78 and 79).  |
| <b>External Fault</b>   | External fault (no voltage on terminal 15)  |
| <b>Brake fault</b>      | <p>(See chapter 6.14.8) The DC drive has not managed to establish the selected torque within the time specified by the Torque Delay parameter.</p> <p>The brake feedback has not been received within the allowed time.</p> <p>The brake feedback remains for 1 second after the closure order has been given to it.</p>  |
| <b>Motor I2t ovrlld</b> | If the <i>Motor I2t accumulator</i> parameter reaches 100% the relative alarm is signalled.   |
| <b>Drive I2t ovrlld</b> | If the <i>Drive I2t accumulator</i> parameter reaches 100% the relative alarm is signalled.   |
| <b>Overcurrent</b>      | Overcurrent (short-circuit / earth fault). The intervention point is determined by the <b>Overcurrent thr</b> parameter. This can also be used as indication of threshold overpass for system applications.   |
| <b>Field loss</b>       | Too low field current. The intervention point corresponds to 50% of the min. field current set with the <b>Flux current min</b> parameter. This alarm message is active with the enabled converter ( <b>Enable drive=Enabled</b> ).   |
| <b>Delta frequency</b>  | This alarm condition is active if the frequency of the three-phase power supply to the drive exceeds the positive or negative percentage threshold set via the <i>Delta freq thres</i> parameter. The power supply frequency (50 or 60 Hz) and thus the relative thresholds are automatically calculated by the drive as soon as the three-phase power supply is available.   |
| <b>Speed fbk loss</b>   | <p>No speed feedback available.</p> <p>When Activity=Warning in the CONFIGURATION /Speed fbk menu is chosen, the <b>Enable fbk bypass</b> parameter has to be set as “Enabled”, otherwise the drive reaches an uncontrolled speed which can not be stopped.</p>   |
| <b>Opt2 failure</b>     | Failure on the card “Option 2” (optional).  |
| <b>Bus loss</b>         | Failure in the connection on the field bus (only in connection with an option card of bus interface).   |
| <b>Hw opt1 failure</b>  | Failure on the card “Option 1” (optional).  |
| <b>Enable seq err</b>   | Wrong drive enabling sequence. The correct sequence is as follows:  |
| Case a:                 | <p><b>Main commands</b> = Terminal</p> <ol style="list-style-type: none"> <li>1 - Regulation board power-up: Enable terminal (term.12) in any state.</li> <li>2 - Drive initialization. Max duration time: 5 s.</li> <li>3 - End of drive initialization. The Enable drive terminal (12) is L (0V).</li> <li>4 - Delay time during which the Enable drive terminal must be L (0V): 1s.</li> <li>5 - Drive enabling. Terminal 12 is H (+24V).</li> </ol> <p>If at the end of the drive initialization (step 3) or during the 1s delay time the Enable drive terminal (term. 12) is High (+24V) a fault is detected</p> |

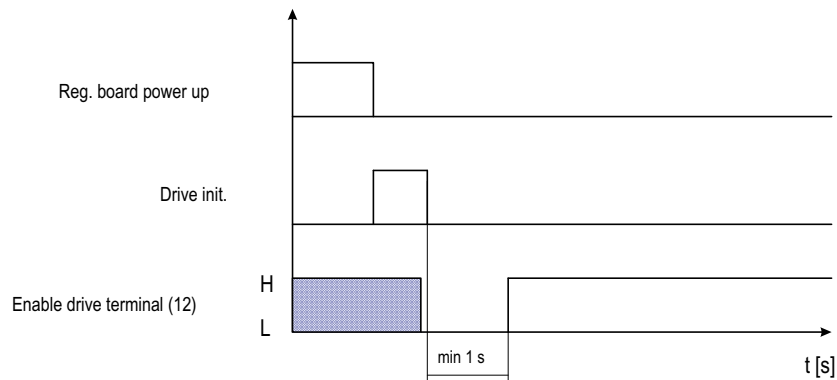

Figure 6.11.8.1 Drive enabling sequence: **Main command** = Terminals

Case b: **Main command** = Digital

- 1 - Regulation board power-up: Enable terminal (term.12) in any state.
  - 2 - Drive initialization. Max duration time: 5 s.
  - 3 - End of drive initialization.
  - 4 - Delay time during which the Enable drive terminal must be L (0V) and **Enable drive** [314] = Disable ( 0 ): 1s. During this time the Process data channels setup initialization occurs.
  - 5 - Drive enabling. Terminal 12 is H (+24V) and **Enable drive** [314] = Enable ( 1 ).
- If at the end of the drive initialization (step 3) or during the 1s delay time the Enable drive terminal (term. 12) is High (+24V) and **Enable drive** [314] = Disable ( 0 ) a fault is detected.

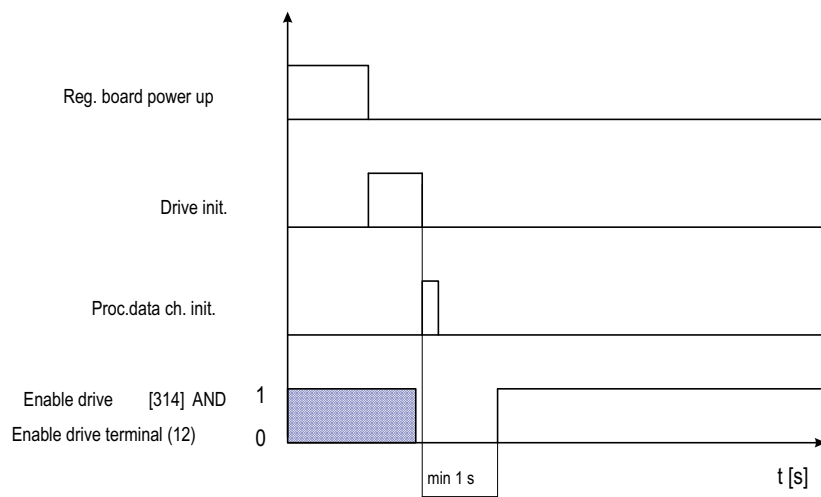

Figure 6.11.8.2 Drive enable sequence: **Main command** = Digital

**In case of fault the reset sequence is as follows:**

Case a: **Latch** = ON

- 1 - Set Enable drive terminal (term. 12) = L (0V)
- 2 - Set **Enable drive** [314] = Disable ( 0 )
- 3 - If **Main commands** = Terminals set Start/Stop terminal (term. 13) = L (0V)
- 4 - Failure reset command. The failure is reset and the drive can work normally.

Case b: **Latch** = OFF

- 1 - Set Enable drive terminal (term. 12) = L (0V) **and** **Enable drive** [314] = Disable (0) for at least 30 ms. The failure is automatically reset.

**Note:** In case of Enable seq err alarm, the behaviour of the Ok Relay function can be affected only if **OK relay funct** = Drive Healty. If **OK relay funct** = Ready to start, the contact will be open anyway.



## 6.11.9 Address for bus operation

| CONFIGURATION   |                  |
|-----------------|------------------|
| Set serial comm |                  |
| [319]           | Device address   |
| [408]           | Ser answer delay |
| [323]           | Ser protocol sel |
| [326]           | Ser baudrate sel |

The configuration modes relating to the serial communication are defined in the submenu **Set serial comm**.

| Parameter description  | No. | Value |     |                  |                  | Standard Configuration |
|--|-----|-------|-----|------------------|------------------|------------------------|
|  |     | min   | max | Factory American | Factory European |                        |
| <b>Device address</b>  | 319 | 0     | 127 | 0                | 0                | -                      |
| <b>Ser answer delay</b>  | 408 | 0     | 900 | 0                | 0                | -                      |
| <b>Ser protocol sel</b><br>SLINK3* (0)<br>MODBUS RTU (1)<br>JBUS (2)                 | 323 | 0     | 2   | SLINK3 (0)       | SLINK3 (0)       | -                      |
| <b>Ser baudrate sel</b><br>19200 (0)<br>9600 (1)<br>4800 (2)<br>2400 (3)<br>1200 (4) | 326 | 0     | 4   | 9600 (1)         | 9600 (1)         | -                      |

\* For SLINK3 the baud rate is steady at 9600.

**Note!** The setting of Ser protocol sel and Ser baudrate sel become active during the Drive start up: they must therefore be stored and the drive has to be switched off. See the specific manual for the numbering system of the registers and coils MODBUS RTU and JBUS.

**Device address** Address with the drive can be accessed if it is networked via the RS485 interface. (For connection see section 4.5. "Serial interface").

**Ser answer delay** Setting of the minimum delay between the receiving of the last byte from the converter and the beginning of its answer. This delay avoids conflicts on the serial line, in case the interface RS485 of the master is not arranged for an automatic communication Tx/Rx.

The parameter only concerns the working with standard serial line RS485.

**Example:** if the delay of the commutation Tx/Rx on the master is at its max. 20ms, the setting of the parameter **Ser answer delay** should be at a higher number of 20ms: 22ms.

**Ser protocol sel** Serial protocol signaling procedure.

**Ser baudrate sel** Baud rate selection (except for SLINK3)

## 6.11.10 Password

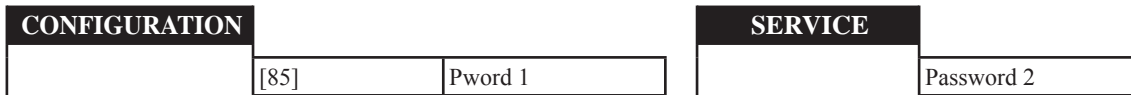

Passwords are used by the operator to protect the parameters from unauthorized access.

| Parameter description | No. | Value |       |                  |                  | Standard Configuration |
|-----------------------|-----|-------|-------|------------------|------------------|------------------------|
|                       |     | min   | max   | Factory American | Factory European |                        |
| <b>Pword 1</b>        | 85  | 0     | 99999 | 0                | 0                | -                      |

**Pword 1** Protects the parameters entered by the user from unauthorized changes. It allows the reset of failure messages (**Failure reset**) and to change on the keypad the **Control mode** even when the bus functioning system has been chosen (**Control mode= Bus**). The password can be freely defined by the user in the form of a 5-digit combination.

Proceed as follows to activate **Pword 1**:

- Select **Pword 1** in the CONFIGURATION menu
- This indicates whether the Password is active (Enabled) or not (Disabled)
- If not, press ENTER and enter the password (see Commissioning).
- Press ENTER once more. The keypad indicates that the Password is active (Enabled).
- The password must be saved so that it is valid when the power supply is switched off and then later switched back on. —> Saving parameters

Proceed as follows to unlock the **Pword 1**:

- Select **Pword** in the CONFIGURATION menu
- The display indicates whether the password is active (Enabled) or not (Disabled)
- If yes, press ENTER and enter the password (see start-up)
- Press ENTER again. The display now indicates that the password is not active (Disabled)
- This configuration must be saved in order to keep the password switched off even after the power supply is turned off and switched back on again. -> Saving parameters

The message **Wrong password** appears if an incorrect password is entered.

If the drive shows the message **EEPROM** the password is deactivated. This takes place the first time the drive is switched on and after a possible change of the operating system.

On delivery the Service menu of the drive is protected by **Password 2**. No **Pword 1** has been entered. The user has free access to all parameters.

**Password 2** cannot be deactivated.

**Note:** In case personal password has been forgotten, it is possible to deactivate it through the setting of the universal password.  
The code of this password is: 51034  
The setting mode of this one remains unchanged compared to the personal password.

## 6.12 I/O CONFIG

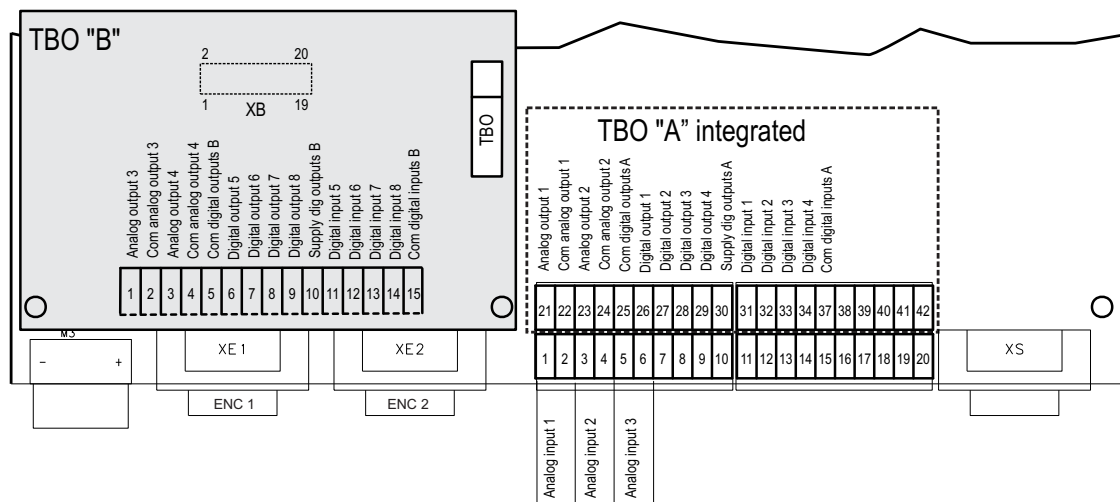

Figure 6.12.1: Arrangement of the programmable I/O

Apart from the terminals which have fixed functions (e.g. for Enables), the converters of the TPD32 series provide the possibility of assigning freely programmable inputs/outputs to particular functions. This can either be carried out via the keypad, the serial interface or any bus connection present.

The freely programmable inputs/outputs are factory set for assignment to the most frequently required functions. However, these can be modified by the user accordingly to meet the requirements of the application at hand.

The device inputs/outputs are subdivided as follows:

- converter with integrated TBO “A”:

- 3 Analog inputs (1...3), designed as differential inputs
- 2 Analog outputs (1 and 2) with common reference point
- 4 Digital outputs (1...4) with common reference point and common voltage supply
- 4 Digital inputs (1...4) with common reference point.

When other digital inputs/outputs and/or analog outputs are required, together with the already existing ones, the TBO option card has to be used, which is inserted on the converter regulation card. A converter card can also be mounted (see figure):

- with TBO “B” option card:

- Option “B”:
- 2 Analog outputs (3 and 4) with common reference point
  - 4 Digital outputs (5 ...8) with common reference point and common voltage supply
  - 4 Digital inputs (5...8) with common reference point.

**Note!**

If parameters are assigned to particular terminals, the parameter value (e.g. speed reference value) can only be entered via this terminal and not via the keypad or bus.

## 6.12.1 Analog Outputs

| I/O CONFIG             |      |                 |
|------------------------|------|-----------------|
| <b>Analog outputs</b>  |      |                 |
| <b>Analog output 1</b> |      |                 |
|                        | [66] | Select output 1 |
|                        | [62] | Scale output 1  |
| <b>Analog output 2</b> |      |                 |
|                        | [67] | Select output 2 |
|                        | [63] | Scale output 2  |
| <b>Analog output 3</b> |      |                 |
|                        | [68] | Select output 3 |
|                        | [64] | Scale output 3  |
| <b>Analog output 4</b> |      |                 |
|                        | [69] | Select output 4 |
|                        | [65] | Scale output 4  |

| Parameter description | No. | Value   |         |                     |                     | Standard Configuration |
|-----------------------|-----|---------|---------|---------------------|---------------------|------------------------|
|                       |     | min     | max     | Factory American    | Factory European    |                        |
| Select output 1       | 66  | 0       | 94      | Actual speed (8)    | Actual speed (8)    |                        |
| Scale output 1        | 62  | Float   | -10.000 | +10.000             | 0.000               | 0.000                  |
| Select output 2       | 67  | 0       | 94      | Motor current (16)  | Motor current (16)  |                        |
| Scale output 2        | 63  | -10.000 | +10000  | 0.000               | 0.000               |                        |
| Select output 3       | 68  | 0       | 94      | Flux<br>-27         | Flux<br>-27         | *                      |
| Scale output 3        | 64  | -10.000 | +10000  | 0.000               | 0.000               |                        |
| Select output 4       | 69  | 0       | 94      | Output voltage (20) | Output voltage (20) | *                      |
| Scale output 4        | 65  | -10.000 | +10000  | 0.000               | 0.000               |                        |

\* TBO option card (TBO "B") has to be installed.

**Select output XX** Selection of the parameter assigned as a variable to the corresponding analog output. The following assignments are possible:

|                               |    |                              |    |                                |    |
|-------------------------------|----|------------------------------|----|--------------------------------|----|
| OFF                           | 0  | Motor current <sup>2)</sup>  | 16 | Out vlt level <sup>3)</sup>    | 79 |
| Speed ref 1 <sup>1)</sup>     | 1  | Output voltage <sup>3)</sup> | 20 | Flux current max <sup>5)</sup> | 80 |
| Speed ref 2 <sup>1)</sup>     | 2  | Analog input 1 <sup>4)</sup> | 24 | F act spd <sup>1)</sup>        | 81 |
| Ramp ref 1 <sup>1)</sup>      | 3  | Analog input 2 <sup>4)</sup> | 25 | F T curr <sup>2)</sup>         | 82 |
| Ramp ref 2 <sup>1)</sup>      | 4  | Analog input 3 <sup>4)</sup> | 26 | Speed draw out <sup>9)</sup>   | 84 |
| Ramp ref <sup>1)</sup>        | 5  | Flux current <sup>5)</sup>   | 27 | Output power <sup>10)</sup>    | 88 |
| Speed ref <sup>1)</sup>       | 6  | Pad 0 <sup>6)</sup>          | 31 | Roll diameter                  | 89 |
| Ramp out <sup>1)</sup>        | 7  | Pad 1 <sup>6)</sup>          | 32 | Act tension ref                | 90 |
| Actual speed <sup>1)</sup>    | 8  | Pad 4 <sup>6)</sup>          | 33 | Torque current                 | 91 |
| T current ref 1 <sup>2)</sup> | 9  | Pad 5 <sup>6)</sup>          | 34 | W reference                    | 92 |
| T current ref 2 <sup>2)</sup> | 10 | Flux reference <sup>7)</sup> | 35 | Actual comp                    | 93 |
| T current ref <sup>2)</sup>   | 11 | Pad 6 <sup>6)</sup>          | 38 | Brake current <sup>11)</sup>   | 94 |
| Speed reg out <sup>2)</sup>   | 15 | PID output <sup>8)</sup>     | 39 |                                |    |

**Scale output XX** Scaling of the analog output concerned

- 1) With a scaling factor of 1 the output supplies 10 V when the reference value or speed corresponds to the value defined by **Speed base value**.
- 2) With a scaling factor of 1, the analog output = 10V when the reference or current is 100%.
- 3) With a scaling factor of 1 the output supplies 10V when the voltage corresponds to the Volt value defined via **Max out voltage**.

- 4) With a scaling factor of 1 the output supplies 10V when the voltage reaches 10V on the analog input (with scaling factor and **Tune value** of the input= 1). See figure 6.12.2.1.
- 5) With a scaling factor of 1 the output supplies 10V when the field current corresponds to **Nom flux curr.**
- 6) With a scaling factor of 1 the output supplies 10V when a Pad value corresponds to 2047.
- 7) With a scaling factor of 1 the output supplies 10V when the field current reference corresponds to **Nom flux curr.**
- 8) For the max. full-scale values, refer to paragraph 6.16.3 **PID function**
- 9) With a scaling factor of 1 the output is 10V when the **Speed ratio** = 20000.
- 10) With a scale factor equal to 1, the output supplies 5 volts to the rated power given by: **Full load current \* Max out voltage**
- 11) Output that monitors the value of the **Torque proving** parameter.

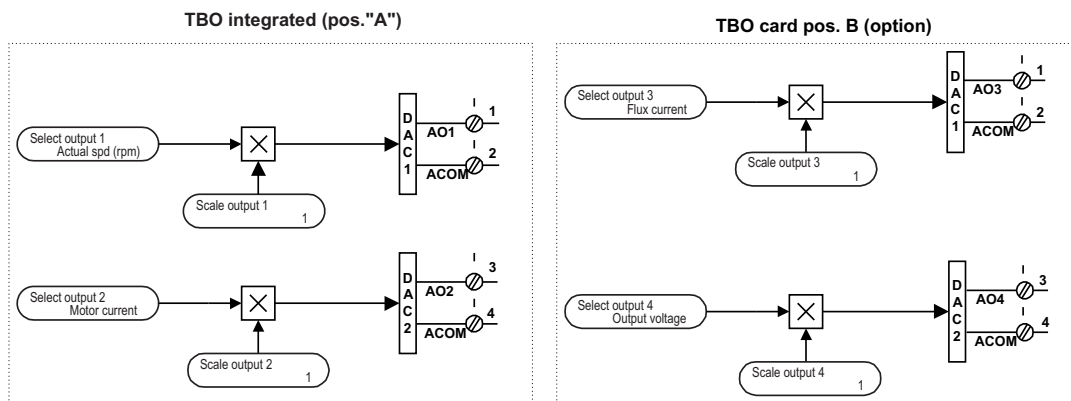

Figure 6.12.1.1: Option card, analog output blocks

#### Example for calculating the scaling factor **Scale output XX**:

You have at your disposal an analog display device for indicating the speed of the drive. The instrument has a measuring range of 0 ... 2 V.

This means that at maximum speed 2 V is required at the analog output of the converter. A scaling factor of 1 would supply 10 V. (Scaling factor = 2 V / 10 V = 0.200).

**Note!** Using Regen Drive (4 quadrant) the analog output supplies bipolar 10V.

## 6.12.2 Analog Inputs

| I/O CONFIG            |                     |
|-----------------------|---------------------|
| <b>Analog inputs</b>  |                     |
| <b>Analog input 1</b> |                     |
| [70]                  | Select input 1      |
| [295]                 | An in 1 target      |
| [71]                  | Input 1 type        |
| [389]                 | Input 1 sign        |
| [72]                  | Scale input 1       |
| [73]                  | Tune value inp 1    |
| [259]                 | Auto tune inp 1     |
| [792]                 | Input 1 filter [ms] |
| [1042]                | Input 1 compare     |
| [1043]                | Input 1 cp error    |
| [1044]                | Input 1 cp delay    |
| [74]                  | Offset input 1      |
| <b>Analog input 2</b> |                     |
| [75]                  | Select input 2      |
| [296]                 | An in 2 target      |
| [76]                  | Input 2 type        |
| [390]                 | Input 2 sign        |
| [77]                  | Scale input 2       |
| [78]                  | Tune value inp 2    |
| [260]                 | Auto tune inp 2     |
| [801]                 | Input 2 filter [ms] |
| [79]                  | Offset input 2      |
| <b>Analog input 3</b> |                     |
| [80]                  | Select input 3      |
| [297]                 | An in 3 target      |
| [81]                  | Input 3 type        |
| [391]                 | Input 3 sign        |
| [82]                  | Scale input 3       |
| [83]                  | Tune value inp 3    |
| [261]                 | Auto tune inp 3     |
| [802]                 | Input 3 filter [ms] |
| [84]                  | Offset input 3      |

| Parameter description  | No.  | Value   |        |                  |                  | Standard Configuration |
|--|------|---------|--------|------------------|------------------|------------------------|
|  |      | min     | max    | Factory American | Factory European |                        |
| <b>Select input 1</b>  | 70   | 0       | 32     | Ramp ref 1 (4)   | Ramp ref 1 (4)   | Terminals 1/2          |
| <b>An in 1 target</b><br>Assigned (0) / Not assigned (1)                               | 295  | 0       | 1      | 0                | 0                |                        |
| <b>Input 1 type</b><br>-10V ... + 10 V (0)<br>0...20 mA, 0...10 V (1)<br>4...20 mA (2) | 71   | 0       | 2      | ± 10 V           | ± 10 V           |                        |
| <b>Input 1 sign</b><br>Positive (1) / Negative (0)                                     | 389  | 0       | 1      | 1                | 1                |                        |
| <b>Input 1 sign +</b>  | -    |         |        |                  |                  | *                      |
| <b>Input 1 sign -</b>  | -    |         |        |                  |                  | *                      |
| <b>Scale input 1</b>   | 72   | -10000  | +10000 | 1.000            | 1.000            |                        |
| <b>Tune value inp 1</b>  | 73   | 0.100   | 10.000 | 1.000            | 1.000            |                        |
| <b>Auto tune inp 1</b><br>Auto tune  | 259  |         |        |                  |                  |                        |
| <b>Input 1 filter [ms]</b>   | 792  | 0       | 1000   | 0                | 0                |                        |
| <b>Input 1 compare</b>   | 1042 | -10000  | +10000 | 0                | 0                |                        |
| <b>Input 1 cp error</b>  | 1043 | 0       | 10000  | 0                | 0                |                        |
| <b>Input 1 cp delay</b>  | 1044 | 0       | 65000  | 0                | 0                |                        |
| <b>Input 1 cp match</b><br>Input 1 not thr.val. (0)<br>Input 1=thr.val (1)             | 1045 | 0       | 1      | -                | -                |                        |
| <b>Offset input 1</b>  | 74   | -32768  | +32767 | 0                | 0                |                        |
| <b>Select input 2</b>  | 75   | 0       | 32     | OFF (0)          | OFF (0)          | Terminals 3/4          |
| <b>An in 2 target</b><br>Assigned (0) / Not assigned (1)                               | 296  | 0       | 1      | 0                | 0                |                        |
| <b>Input 2 type</b><br>-10V ... + 10 V (0)<br>0...20 mA, 0...10 V (1)<br>4...20 mA (2) | 76   | 0       | 2      | ± 10 V           | ± 10 V           |                        |
| <b>Input 2 sign</b><br>Positive (1) / Negative (0)                                     | 390  | 0       | 1      | 1                | 1                |                        |
| <b>Input 2 sign +</b>  | -    |         |        |                  |                  | *                      |
| <b>Input 2 sign -</b>  | -    |         |        |                  |                  | *                      |
| <b>Scale input 2</b>   | 77   | -10.000 | +10000 | 1.000            | 1.000            |                        |
| <b>Tune value inp 2</b>  | 78   | 0.100   | 10.000 | 1.000            | 1.000            |                        |
| <b>Auto tune inp 2</b><br>Auto tune  | 260  |         |        |                  |                  |                        |
| <b>Input 2 filter [ms]</b>   | 801  | 0       | 1000   | 0                | 0                |                        |
| <b>Offset input 2</b>  | 79   | -32768  | +32767 | 0                | 0                |                        |
| <b>Select input 3</b>  | 80   | 0       | 32     | OFF (0)          | OFF (0)          | Terminals 5/6          |
| <b>An in 3 target</b><br>Assigned (0) / Not assigned (1)                               | 297  | 0       | 1      | 0                | 0                |                        |
| <b>Input 3 type</b><br>-10V ... + 10 V (0)<br>0...20 mA, 0...10 V (1)<br>4...20 mA (2) | 81   | 0       | 2      | ± 10 V           | ± 10 V           |                        |
| <b>Input 3 sign</b><br>Positive (1) / Negative (0)                                     | 391  | 0       | 1      | 1                | 1                |                        |
| <b>Input 3 sign +</b>  | -    |         |        |                  |                  | *                      |
| <b>Input 3 sign -</b>  | -    |         |        |                  |                  | *                      |
| <b>Scale input 3</b>   | 82   | -10.000 | +10000 | 1.000            | 1.000            |                        |
| <b>Tune value inp 3</b>  | 83   | 0.100   | 10.000 | 1.000            | 1.000            |                        |
| <b>Auto tune inp 3</b><br>Auto tune  | 261  |         |        |                  |                  |                        |
| <b>Input 3 filter [ms]</b>   | 802  | 0       | 1000   | 0                | 0                |                        |
| <b>Offset input 3</b>  | 84   | -32768  | +32767 | 0                | 0                |                        |

\* This function can be assigned to one of the programmable digital inputs.

\*\* This parameter can be assigned to one of the programmable digital outputs.

## Select input XX

Selection of the parameter to be assigned its value via an analog input. The following assignments are possible:

|                               |   |                               |    |                           |    |
|-------------------------------|---|-------------------------------|----|---------------------------|----|
| OFF                           | 0 | T current lim + <sup>2)</sup> | 10 | Flux current max          | 25 |
| Jog reference <sup>1)</sup>   | 1 | T current lim - <sup>2)</sup> | 11 | Out vlt level             | 26 |
| Speed ref 1 <sup>1)</sup>     | 2 | Pad 0 <sup>3)</sup>           | 12 | Speed ratio <sup>5)</sup> | 28 |
| Speed ref 2 <sup>1)</sup>     | 3 | Pad 1 <sup>3)</sup>           | 13 | Tension red               | 29 |
| Ramp ref 1 <sup>1)</sup>      | 4 | Pad 2 <sup>3)</sup>           | 14 | Tension ref               | 30 |
| Ramp ref 2 <sup>1)</sup>      | 5 | Pad 3 <sup>3)</sup>           | 15 | Preset 3                  | 31 |
| T current ref 1 <sup>2)</sup> | 6 | Load comp                     | 19 | Brake Ref *               | 32 |
| T current ref 2 <sup>2)</sup> | 7 | PID offset 0 <sup>4)</sup>    | 21 |                           |    |
| Adap reference <sup>1)</sup>  | 8 | PI central v3 <sup>4)</sup>   | 22 |                           |    |
| T current limit <sup>2)</sup> | 9 | PID feed-back <sup>4)</sup>   | 23 |                           |    |

\* Reference for the **Torque proving** parameter setting.

## An in xx target

Assign the analog input xx sampling. If **assigned**, the sampled value is copied into the parameter programmed on the analog input. If **not assigned**, the programmed parameter takes the value preset via keypad or RS485 or BUS, before to assign an analog input. Exception are the "PAD" parameters, where the last value on the analog input is stored when An in XX target = not assigned is executed.

## Input XX type

Selection of input type (voltage or current input)

Jumpers on the regulator card of the TPD32 should be fitted or removed according to the input signal used. The inputs of the device are factory set for voltage signals.

| Analog Input   | Input Signal     |           |
|----------------|------------------|-----------|
|                | -10 V ... + 10 V | 0 - 20 mA |
|                | 0 - 10 V         | 4 - 20 mA |
| Analog input 1 | S9 = OFF         | S9 = ON   |
| Analog input 2 | S10 = OFF        | S10 = ON  |
| Analog input 3 | S11 = OFF        | S11 = ON  |

GD6185g

|               |  |
|---------------|--|
| ON            | Jumper fitted  |
| OFF           | Jumper not fitted  |
| 10 V...+10 V  | A voltage of max $\pm 10$ V is connected to the analog input concerned. If the signal is used as a reference value, a polarity reversal can be used to reverse the rotation direction of the drive (only with TPD32...4B converters). The TPD32...2B converters accept as speed reference only positive references. Negative references are not accepted and the drive does not start. |
| 0-10V, 0-20mA | A voltage of max. 10 V or a current signal of 0...20 mA is connected to the analog input concerned. The signal must be positive. If the signal is used as a reference value for TPD32...4B converters, the rotation direction can be reversed via the <b>Input XX sign +</b> and <b>Input XX sign -</b> parameters.  |
| 4-20 mA       | A current signal of 4...20 mA is connected to the analog input concerned. The signal must be positive. If the signal is used as a reference value for TPD32...4B converters, the drive rotation direction can be reversed via the <b>Input XX sign +</b> and <b>Input XX sign -</b> parameters.  |

## Input XX sign

Selection of rotation direction when operated via the serial interface or bus for the tetraquadrant TPD32...4B converters.

## Input XX sign +

Selection of "Clockwise" rotation when operated via the terminal strip for the TPD32...4B converters, when the reference value is only given with one polarity.

|      |                        |
|------|------------------------|
| High | Clockwise selected     |
| Low  | Clockwise not selected |



**Input XX sign -** Selection of “Counter-clockwise” rotation when operated via the terminal strip for the TPD32...4B converters, when the reference value is only given with one polarity.

|      |                               |
|------|-------------------------------|
| High | Counterclockwise selected     |
| Low  | Counterclockwise not selected |

If both **Input XX sign+** and **Input XX sign-** are 0 or 1 the reference value is zero.

**Scale input XX** Scaling of the corresponding analog input

- 1) With a scaling factor of 1 and a **Tune value inp XX** = 1, 10 V or 20 mA on the input correspond to the **Speed base value**.
- 2) With a scaling factor of 1 and a **Tune value inp XX** = 1, 10 V or 20 mA on the input correspond to max possible current.
- 3) With a scaling factor of 1, 10V or 20 mA in the input correspond to the Pad value of 2047.
- 4) For the max. full scale values, refer to paragraph 6.16.3 **PID function**
- 5) With a scaling factor of 1.0 and **Tune value inp XX**=1, 10V or 20mA correspond to **Speed ratio** = 20000.

**Tune value inp XX** Fine tuning of the input when the max. signal does not exactly correspond to the rated value. Example see below.

**Auto tune inp XX** Automatic fine tuning of the input. If this command is given, **Tune value inp XX** is automatically selected so that the input signal present corresponds to the max. variable value, such as the **Speed base value**. Two conditions are necessary for automatic fine tuning:

- Input voltage greater than 1 V or input current greater than 2 mA
- Positive polarity. The value found is automatically set for the other direction for the TPD32...4B converters.

*Note:* The automatically calculated value can, if necessary, be modified manually via **Tune value inp XX**.

**Input X filter** Filtering of analog input X measurement.

**Offset inp XX** If the analog signal has an offset or if the variable assigned to the input already has a value although there is no input signal present, this can be compensated via the **Offset inp XX**.

The converter is factory set so that analog values as +10V/-10V.

With field bus operation (Option), the **Input XX sign** parameter specifies the sign for the rotation direction.

If a parameter is already internally assigned (e.g. if **Speed ref 1** is automatically connected with the ramp output when the ramp is enabled), it will no longer appear in the list of parameters that can be assigned to an analog input.

The **Input XX sign +** and **Input sign -** parameters cannot be addressed via the serial interface.

**Example 1:** The speed reference value of a drive is defined with an external voltage of 5V. With this value the drive should reach the max. allowed speed (set via **Sped base value**).  
As parameter **Scale input XX** the scaling factor 2 is entered (10V : 5V)

**Example 2:** An external analog reference reaches only max. 9.8V instead of 10V.  
As parameter **Tune value inp XX** 1.020 is entered (10V : 9.8V).  
The same result would have been obtained via the **Auto tune inp XX** function. The appropriate parameters would have to be entered in the menu of the keypad. The maximum possible analog value (in this case 9.8 V) would have to be present at the terminal with a positive polarity. The keypad will adjust the “Tune value” automatically if the ENTER key is pressed.

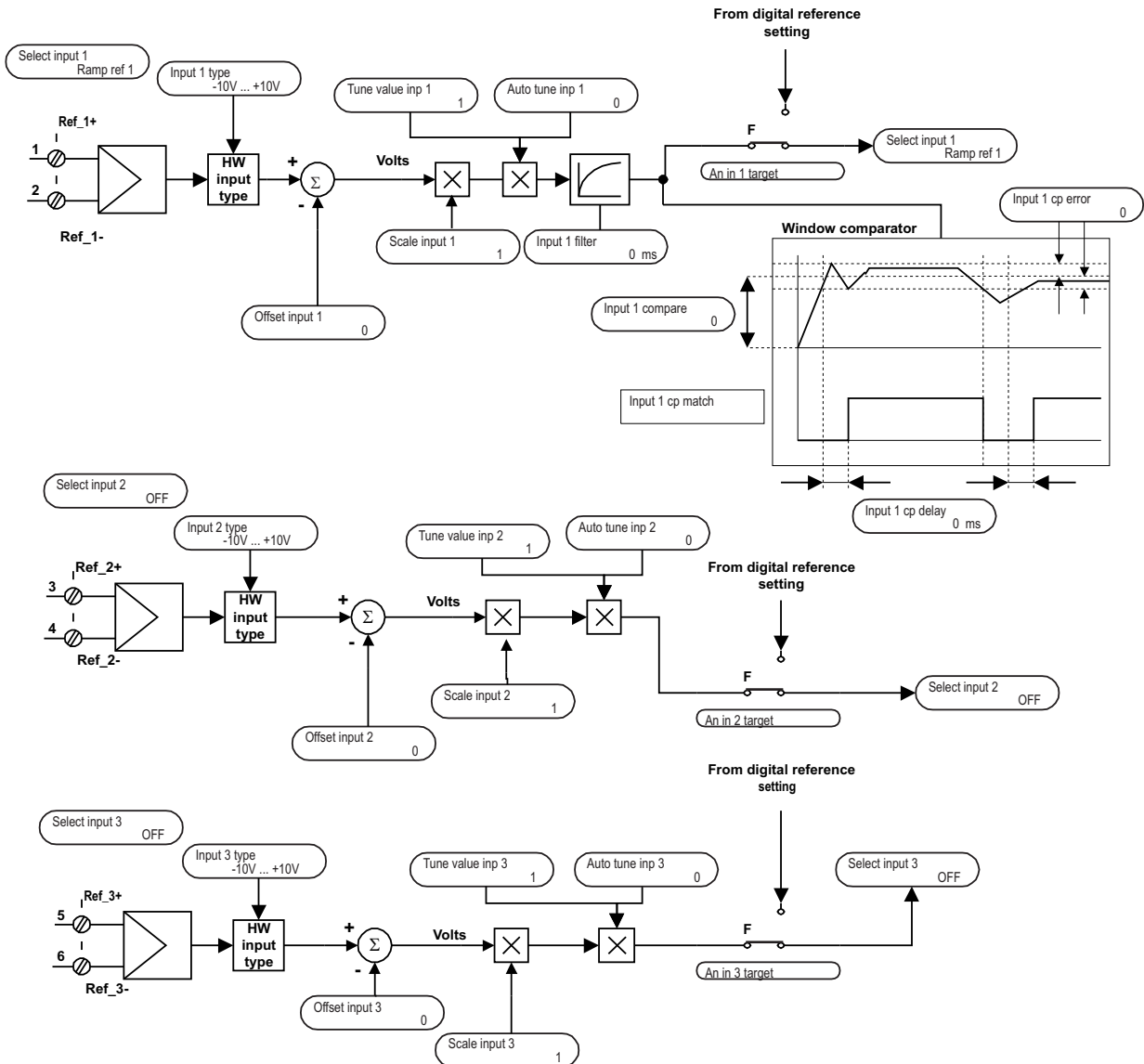

Figure 6.12.2.1: Analog input

### Analog Input 1 window comparator

This function allows to signal the match of a programmable value on analog input 1.

- Input 1 compare** Sets the level for the comparator.
- Input 1 cp error** Defines a tolerance window around **Input 1 compare**.
- Input 1 cp delay** Millisecond delay during the switching from the low to the high level **Input 1 cp match**.
- Input 1 cp match** Signalling output of the video comparator.  
It can be read through a Field Bus LAN or digital output.  
High **Analog input 1** value is within the comparison window.  
Low **Analog input 1** value is out the comparison window.

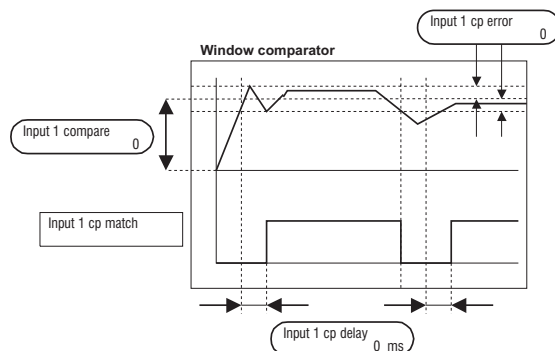

Figure 6.12.2.2: Analog Input 1 window comparator

**Note!**

How to calculate Input 1 compare and Input 1 cp error parameters:  
 Input 1 compare = (Compare value) \* 10000 / (Full range value)  
 Input 1 error = (Tolerance half window) 10000 / (Full range value)

**Example 1:**

Select analog input 1 to **Ramp ref 1**

**Speed base value** equal to 1500 [RPM]

10Volt or 20 mA on analog input 1 (Ramp ref 1=Speed base value).

The application requires a signaling at 700 [RPM] via a digital output, with a tolerance window equal to 100 [RPM]

**Input 1 cp match** assigned to a programmable digital output.

**Input 1 compare** =  $700 * 10000 / 1500 = 4667$

**Input 1 cp error** =  $100 * 10000 / 1500 = 666$

**Example 2:**

Select analog input 1 to **Ramp ref 1**

**Speed base value** equal to 1500 [RPM]

10Volt or 20 mA on **Analog input 1 (Ramp ref 1=Speed base value)**.

The application requires a signaling at -700 [RPM] via LAN, with a tolerance window equal to  $\pm 100$  [RPM]

**Input 1 compare** =  $-700 * 10000 / 1500 = -4667$

**Input 1 cp error** =  $100 * 10000 / 1500 = 666$

**Example 3:**

Select analog input 1 to **Pad 0**

10Volt or 20 mA on **Analog input 1** corresponds to Pad 0=2047.

The application requires a signaling at 700 [count] via a digital output, with a tolerance window equal to  $\pm 50$  [count]

**Input 1 cp match** assigned to a programmable digital output

**Input 1 compare** =  $700 * 10000 / 2047 = 3420$

**Input 1 cp error** =  $50 * 10000 / 2047 = 244$

**Example 4:**

Select analog input 1 to **PID feedback**

10Volt or 20 mA on **Analog input 1** corresponds to **PID feedback**=10000.

The application requires a signaling at 4000 [count] via a digital output, with a tolerance band equal to  $\pm 1000$  [count]

**Input 1 cp match** assigned to a programmable digital output

**Input 1 compare** =  $4000 * 10000 / 10000 = 4000$

**Input 1 cp error** =  $1000 * 10000 / 10000 = 1000$

**Example 5:**

Select input 1 to **T current lim**

10Volt or 20 mA on **Analog input 1** corresponds to **T current lim** = 100 [%]

The application requires a signaling at 50 [%] via a digital output, with a tolerance band equal to  $\pm 2$  [%]

**Input 1 cp match** assigned to a programmable digital output

**Input 1 compare** =  $50 * 10000 / 100 = 5000$

**Input 1 cp error** =  $2 * 10000 / 100 = 200$

### 6.12.3 Digital Outputs

| I/O CONFIG      |                   |                  |
|-----------------|-------------------|------------------|
| Digital outputs | [145]             | Digital output 1 |
|                 | [1267]            | Inversion out 1  |
|                 | [146]             | Digital output 2 |
|                 | [1268]            | Inversion out 2  |
|                 | [147]             | Digital output 3 |
|                 | [1269]            | Inversion out 3  |
|                 | [148]             | Digital output 4 |
|                 | [1270]            | Inversion out 4  |
|                 | [149]             | Digital output 5 |
|                 | [1271]            | Inversion out 5  |
|                 | [150]             | Digital output 6 |
|                 | [1272]            | Inversion out 6  |
|                 | [151]             | Digital output 7 |
|                 | [1273]            | Inversion out 7  |
|                 | [152]             | Digital output 8 |
|                 | [1274]            | Inversion out 8  |
|                 | [629]             | Relay 2          |
| [1275]          | Inversion relay 2 |                  |

| Parameter description                                  | No.  | Value |     |                     |                     | Standard Configuration |
|--|------|-------|-----|---------------------|---------------------|------------------------|
|  |      | min   | max | Factory American    | Factory European    |                        |
| <b>Digital output 1</b>                                | 145  | 0     | 77  | Ramp + (8)          | Ramp + (8)          |                        |
| <b>Inversion out 1</b><br>Enabled (1) / Disabled (0)   | 1267 | 0     | 1   | Disabled (0)        | Disabled (0)        |                        |
| <b>Digital output 2</b>                                | 146  | 0     | 77  | Ramp - (9)          | Ramp - (9)          |                        |
| <b>Inversion out 2</b><br>Enabled (1) / Disabled (0)   | 1268 | 0     | 1   | Disabled (0)        | Disabled (0)        |                        |
| <b>Digital output 3</b>                                | 147  | 0     | 77  | Spd thr. (2)        | Spd thr. (2)        |                        |
| <b>Inversion out 3</b><br>Enabled (1) / Disabled (0)   | 1269 | 0     | 1   | Disabled (0)        | Disabled (0)        |                        |
| <b>Digital output 4</b>                                | 148  | 0     | 77  | Overld avail. (6)   | Overld avail. (6)   |                        |
| <b>Inversion out 4</b><br>Enabled (1) / Disabled (0)   | 1270 | 0     | 1   | Disabled (0)        | Disabled (0)        |                        |
| <b>Digital output 5</b>                                | 149  | 0     | 77  | Curr lim. state (4) | Curr lim. state (4) |                        |
| <b>Inversion out 5</b><br>Enabled (1) / Disabled (0)   | 1271 | 0     | 1   | Disabled (0)        | Disabled (0)        |                        |
| <b>Digital output 6</b>                                | 150  | 0     | 77  | Over-voltage (12)   | Over-voltage (12)   |                        |
| <b>Inversion out 6</b><br>Enabled (1) / Disabled (0)   | 1272 | 0     | 1   | Disabled (0)        | Disabled (0)        |                        |
| <b>Digital output 7</b>                                | 151  | 0     | 77  | Under-voltage (11)  | Under-voltage (11)  |                        |
| <b>Inversion out 7</b><br>Enabled (1) / Disabled (0)   | 1273 | 0     | 1   | Disabled (0)        | Disabled (0)        |                        |
| <b>Digital output 8</b>                                | 152  | 0     | 77  | Over-current (14)   | Over-current (14)   |                        |
| <b>Inversion out 8</b><br>Enabled (1) / Disabled (0)   | 1274 | 0     | 1   | Disabled (0)        | Disabled (0)        |                        |
| <b>Relay 2</b>   | 629  | 0     | 77  | Stop ctrl (23)      | Stop ctrl (23)      |                        |
| <b>Inversion relay 2</b><br>Enabled (1) / Disabled (0) | 1275 | 0     | 1   | Disabled (0)        | Disabled (0)        |                        |

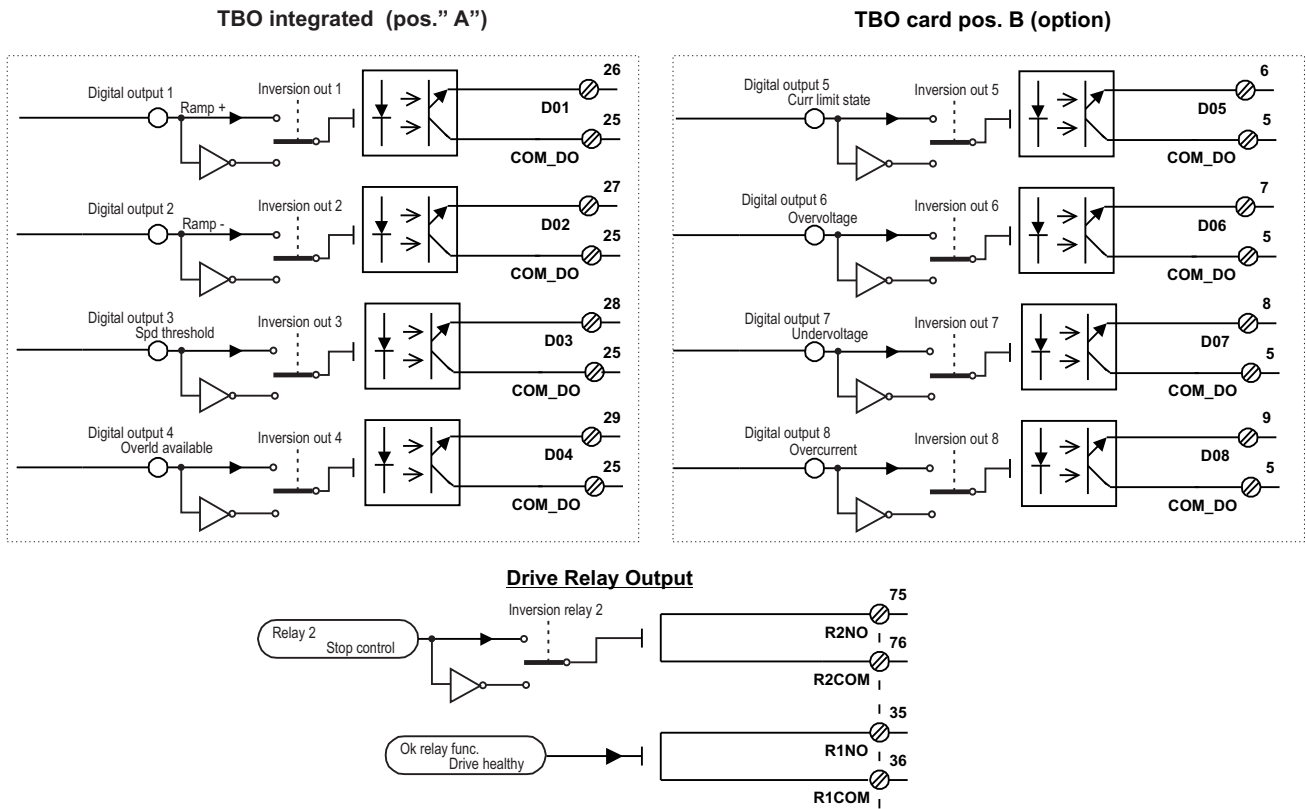

Figure 6.12.3.1: Digital outputs

**Digital output XX**

Selection of the parameter that is assigned to the digital output concerned. The following assignments are possible:

|                                |    |                                |    |                                   |    |
|--------------------------------|----|--------------------------------|----|-----------------------------------|----|
| OFF                            | 0  | Pad A bit                      | 18 | Acc state                         | 60 |
| Speed zero thr                 | 1  | Pad B bit                      | 19 | Dec state                         | 61 |
| Spd threshold                  | 2  | Virt dig input                 | 20 | Brake comand <sup>2)</sup>        | 62 |
| Set speed                      | 3  | Torque sign                    | 21 | Brake failure <sup>3)</sup>       | 63 |
| Curr limit state               | 4  | Stop control                   | 23 | Mot ovrlld preal <sup>4)</sup>    | 65 |
| Drive ready                    | 5  | Field loss                     | 24 | Dvr ovrlld preal <sup>5)</sup>    | 66 |
| Mot ovrlld avail <sup>6)</sup> | 6  | Speed fbk loss                 | 25 | Dvr ovrlld avail <sup>7)</sup>    | 67 |
| Overload state                 | 7  | Bus loss                       | 26 | I2t mot ovrlld fail <sup>8)</sup> | 68 |
| Ramp +                         | 8  | Hw opt1 failure                | 28 | I2t drv ovrlld fail <sup>9)</sup> | 69 |
| Ramp -                         | 9  | Opt2 failure                   | 29 | Mot cur threshld <sup>10)</sup>   | 70 |
| Speed limited                  | 10 | Encoder 1 state                | 30 | Overspeed <sup>11)</sup>          | 71 |
| Undervoltage                   | 11 | Encoder 2 state                | 31 | Delta frequency <sup>12)</sup>    | 72 |
| Overvoltage                    | 12 | Enable seq err                 | 35 | Drv rdy to start <sup>14)</sup>   | 76 |
| Heatsink                       | 13 | Diameter calc st <sup>1)</sup> | 38 | BUS control mode <sup>15)</sup>   | 77 |
| Overcurrent                    | 14 | Drive healthy <sup>13)</sup>   | 42 |                                   |    |
| Overtmp motor                  | 15 | Input 1 cp match               | 49 |                                   |    |
| External fault                 | 16 | Diam reached                   | 58 |                                   |    |
| Failure supply                 | 17 | Spd match compl                | 59 |                                   |    |

- 1) Refer to paragraph 6.16.3 PID function
- 2) brake relay control; indicates the presence of adequate current to support the load (**Torque proving**) parameter..
- 3) brake alarm signal.
- 4) this signal is enabled when the thermal image of the motor **Motor I2t accum** = 90 % and returns to 0 when **Motor I2t accum** = 0.
- 5) this signal is enabled when the thermal image of the drive **Drive I2t accum** = 90 % and returns to 0 when **Drive I2t accum** = 0.
- 6) The default condition of this signal is enabled. It is disabled when **Motor I2t accum** = 100 % and is re-enabled when **Motor I2t accum** = 0.

- 7) The default condition of this signal is enabled. It is disabled when **Drive I2t accum = 100 %** and is re-enabled when **Drive I2t accum = 0**.
- 8) I2t motor overload alarm signal.
- 9) I2t drive overload alarm signal.
- 10) current threshold exceeded signal.
- 11) overspeed alarm signal.
- 12) frequency alarm signal.
- 13) The following drive condition is signalled, via a digital output:
  - regulator power supply present
  - no alarms present
- 14) The following drive condition is signalled, via a digital output:
  - power supply present
  - no alarms present
  - Enable signal present
  - three-phase network synchronisation achieved
  - excitation current present (only necessary if Field Loss alarm Activity is other than IGNORE)
- 15) A signal is sent via a digital output to indicate whether the drive is in a data transfer via fieldbus condition (Control mode = BUS).

**Inversion out XX** Reverse the digital outputs signal.

**Relay 2** Selection of the parameters, that are assigned to the relay contact on terminals 75 and 76 has to trip.

**Note!** As for an alarm signal the following are valid:  
 Output = Low and open relay contact: Alarm  
 Output = High and closed relay contact: No alarm  
 See the chapters concerning the output behavior with other messages.

## 6.12.4 Digital Inputs

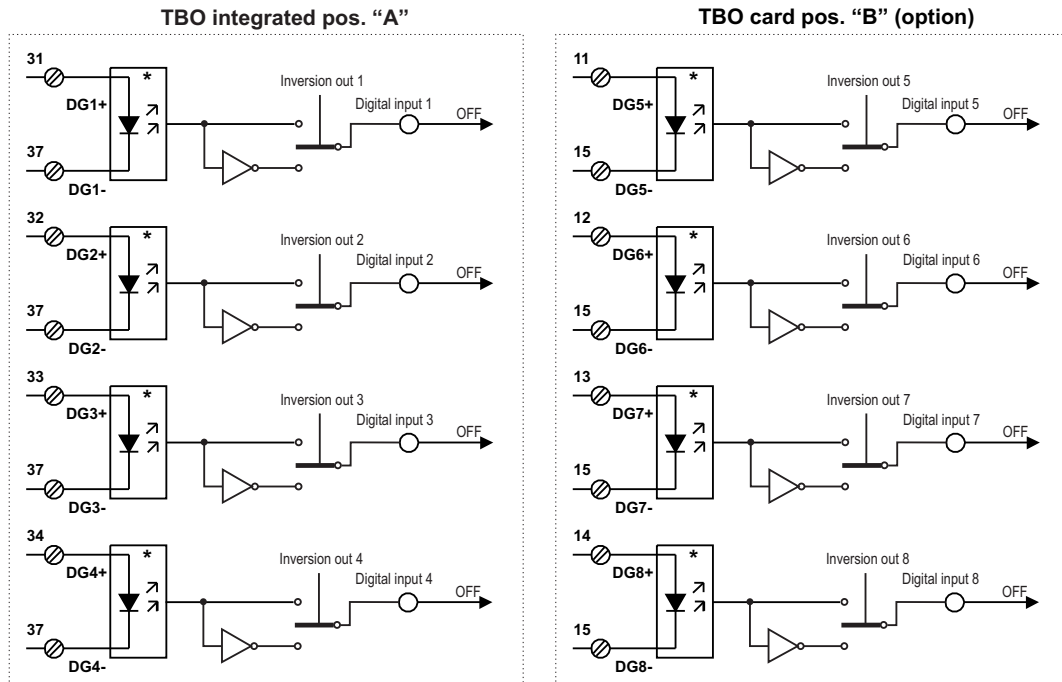

Figure 6.12.4.1: Digital inputs

| I/O CONFIG     |                       |
|----------------|-----------------------|
| Digital inputs |                       |
|                | 137 Digital input 1   |
|                | [1276] Inversion in 1 |
|                | [138] Digital input 2 |
|                | [1277] Inversion in 2 |
|                | [139] Digital input 3 |
|                | [1278] Inversion in 3 |
|                | [140] Digital input 4 |
|                | [1279] Inversion in 4 |
|                | [141] Digital input 5 |
|                | [1280] Inversion in 5 |
|                | [142] Digital input 6 |
|                | [1281] Inversion in 6 |
|                | [143] Digital input 7 |
|                | [1282] Inversion in 7 |
|                | [144] Digital input 8 |
|                | [1283] Inversion in 8 |

| Parameter description                                | No.  | Value |     |                  |                  | Standard Configuration |
|--|------|-------|-----|------------------|------------------|------------------------|
|  |      | min   | max | Factory American | Factory European |                        |
| <b>Digital input 1</b>                               | 137  | 0     | 87  | OFF (0)          | OFF (0)          |                        |
| <b>Inversion in 1</b><br>Enabled (1)<br>Disabled (0) | 1267 | 0     | 1   | Disabled (0)     | Disabled (0)     |                        |
| <b>Digital input 2</b>                               | 146  | 0     | 87  | OFF (0)          | OFF (0)          |                        |
| <b>Inversion in 2</b><br>Enabled (1)<br>Disabled (0) | 1268 | 0     | 1   | Disabled (0)     | Disabled (0)     |                        |
| <b>Digital input 3</b>                               | 147  | 0     | 87  | OFF (0)          | OFF (0)          |                        |
| <b>Inversion in 3</b><br>Enabled (1)<br>Disabled (0) | 1269 | 0     | 1   | Disabled (0)     | Disabled (0)     |                        |
| <b>Inversion in 4</b><br>Enabled (1)<br>Disabled (0) | 1270 | 0     | 1   | Disabled (0)     | Disabled (0)     |                        |
| <b>Digital in 5</b>                                  | 149  | 0     | 87  | OFF (0)          | OFF (0)          |                        |
| <b>Inversion in 5</b><br>Enabled (1)<br>Disabled (0) | 1271 | 0     | 1   | Disabled (0)     | Disabled (0)     |                        |
| <b>Digital in 6</b>                                  | 150  | 0     | 87  | OFF (0)          | OFF (0)          |                        |
| <b>Inversion in 6</b><br>Enabled (1)<br>Disabled (0) | 1272 | 0     | 1   | Disabled (0)     | Disabled (0)     |                        |
| <b>Digital in 7</b>                                  | 151  | 0     | 87  | OFF (0)          | OFF (0)          |                        |
| <b>Inversion in 7</b><br>Enabled (1)<br>Disabled (0) | 1273 | 0     | 1   | Disabled (0)     | Disabled (0)     |                        |
| <b>Digital in 8</b>                                  | 152  | 0     | 87  | OFF (0)          | OFF (0)          |                        |
| <b>Inversion in 8</b><br>Enabled (1)<br>Disabled (0) | 1274 | 0     | 1   | Disabled (0)     | Disabled (0)     |                        |

## Digital input XX

Selection of the parameter that is addressed by the digital input concerned. The following assignments are possible:

|                              |    |                                  |    |                              |    |
|------------------------------|----|----------------------------------|----|------------------------------|----|
| OFF                          | 0  | Speed sel 1 <sup>2)</sup>        | 24 | PID offs. Sel <sup>4)</sup>  | 55 |
| Motor pot reset              | 1  | Speed sel 2 <sup>2)</sup>        | 25 | PI central vs0 <sup>4)</sup> | 56 |
| Motor pot up                 | 2  | Ramp sel 0 <sup>3)</sup>         | 26 | PI central vs1 <sup>4)</sup> | 57 |
| Motor pot down               | 3  | Ramp sel 1 <sup>3)</sup>         | 27 | Diameter calc <sup>4)</sup>  | 58 |
| Motor pot sign +             | 4  | Field loss                       | 29 | Diam reset                   | 68 |
| Motor pot sign -             | 5  | Enable flux reg                  | 30 | Diam calc Dis                | 69 |
| Jog +                        | 6  | Enable flux weak                 | 31 | Torque winder EN             | 70 |
| Jog -                        | 7  | Pad A bit 0                      | 32 | Line acc status              | 71 |
| Failure reset                | 8  | Pad A bit 1                      | 33 | Line dec status              | 72 |
| Torque reduct                | 9  | Pad A bit 2                      | 34 | Line fstp status             | 73 |
| Ramp out = 0                 | 10 | Pad A bit 3                      | 35 | Speed match                  | 74 |
| Ramp in = 0                  | 11 | Pad A bit 4                      | 36 | Diam inc/dec En              | 75 |
| Freeze ramp                  | 12 | Pad A bit 5                      | 37 | Wind/unwind                  | 76 |
| Lock speed reg               | 13 | Pad A bit 6                      | 38 | Diam preset SEL0             | 77 |
| Lock speed I                 | 14 | Pad A bit 7                      | 39 | Diam preset SEL1             | 78 |
| Auto capture                 | 15 | Forward sign                     | 44 | Taper enable                 | 79 |
| Input 1 sign + <sup>1)</sup> | 16 | Reverse sign                     | 45 | Speed demand En              | 80 |
| Input 1 sign - <sup>1)</sup> | 17 | An in 1 target                   | 46 | Winder side                  | 81 |
| Input 2 sign + <sup>1)</sup> | 18 | An in 2 target                   | 47 | Enable PI-PD PID             | 82 |
| Input 2 sign - <sup>1)</sup> | 19 | An in 3 target                   | 48 | Jog TW enable                | 83 |
| Input 3 sign + <sup>1)</sup> | 20 | Enable droop                     | 49 | Brake fbk <sup>5)</sup>      | 84 |
| Input 3 sign - <sup>1)</sup> | 21 | Enable PI PID <sup>4)</sup>      | 52 | Adapt Sel 1 <sup>6)</sup>    | 86 |
| Zero torque                  | 22 | Enable PD PID <sup>4)</sup>      | 53 | Adapt Sel 2 <sup>7)</sup>    | 87 |
| Speed sel 0 <sup>2)</sup>    | 23 | PI integral freeze <sup>4)</sup> | 54 |                              |    |

- 1) The **Input xx sign +** and **Input XX sign -** parameters can only be used in conjunction with the other parameter.
- 2) The **Speed sel 0**, **Speed sel 1** and **Speed sel 2** parameters can only be used together.



- 3) The **Ramp sel 0** and **Ramp sel 1** parameters can only be used together.
- 4) Refer to paragraph 6.16.3 **PID function**
- 5) brake relay feedback; this command is necessary in order for the brake to be released or closed without generating the alarm
- 6) Gains value selection with the significance 2<sup>1</sup>
- 7) Gains value selection with the significance 2<sup>2</sup>

**Inversion in XX** Reverse the digital inputs signal.

### 6.12.5 Speed reference from encoder input (Tach follower function)

#### I/O CONFIG

#### Encoder inputs

|        |                  |
|--------|------------------|
| [1020] | Select enc 1     |
| [1021] | Select enc 2     |
| [416]  | Encoder 1 pulses |
| [169]  | Encoder 2 pulses |
| [649]  | Refresh enc 1    |

| Parameter description  | No.  | Value |      |                  |                  | Standard Configuration |
|--|------|-------|------|------------------|------------------|------------------------|
|  |      | min   | max  | Factory American | Factory European |                        |
| <b>Select enc 1</b><br>OFF (0)<br>Speed ref 1 (1)<br>Speed ref 2 (2)<br>Ramp ref 1 (3)<br>Ramp ref 2 (4) | 1020 | 0     | 5    | OFF (0)          | OFF (0)          |                        |
| <b>Select enc 2</b><br>OFF (0)<br>Speed ref 1 (1)<br>Speed ref 2 (2)<br>Ramp ref 1 (3)<br>Ramp ref 2 (4) | 1021 | 0     | 5    | OFF (0)          | OFF (0)          |                        |
| <b>Encoder 1 pulses</b>  | 416  | 600   | 9999 | 1024             | 1024             |                        |
| <b>Encoder 2 pulses</b>  | 169  | 150   | 9999 | 1024             | 1024             |                        |
| <b>Refresh enc 1</b><br>Enabled (1)<br>Disabled (0)  | 649  | 0     | 1    | Disabled (0)     | Disabled (0)     |                        |
| <b>Refresh enc 2</b><br>Enabled (1)<br>Disabled (0)  | 652  | 0     | 1    | Disabled (0)     | Disabled (0)     |                        |

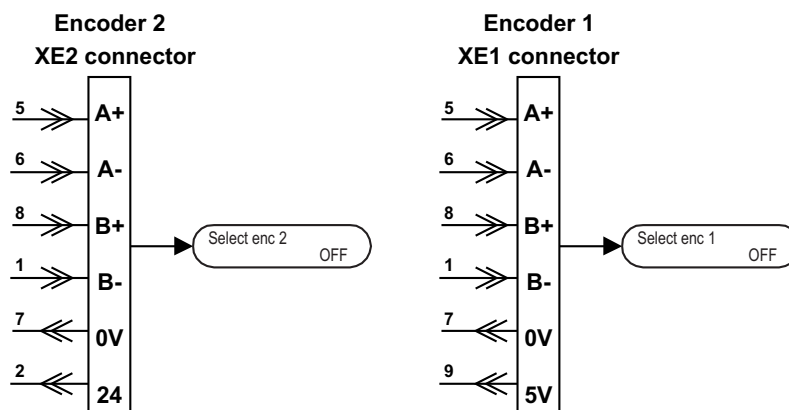

Figure 6.12.5.1: Tach follower

This configuration allows the use of the encoder inputs, as a speed reference. Compared to an analog input, these inputs have higher resolution and higher noise immunity.

Using for this purpose the encoder input (XE1 or XE2 connector), it is necessary to define the destination, selecting properly the type of speed reference on which it has to interact (**Ramp ref 1**, **Speed ref 1**, etc.)

When the encoder input is used as a speed reference source, using the same encoder input as speed feedback is disallowed. It is impossible to configure the same speed reference to the encoder input and an analog input.

The function “Tach follower” can be used in accordance with the table below:

| Speed fbk sel [414] | Encoder 1 as reference | Encoder 2 as reference |
|---------------------|------------------------|------------------------|
| Encoder 1           | Not available          | Not available          |
| Encoder 2           | Available              | Not available          |
| Tacho               | Not available          | Available              |
| Armature            | Available              | Available              |

DV0727g

**Note!** It is possible to set any configuration. Follow the configuration possible in the table above.

- Select enc 1** These parameters define which speed reference the encoder signal will reference to.
- Select enc 2** The OFF condition indicates that the encoder connector is not used as speed reference and then it could be used as speed feedback. (CONFIGURATION/Speed fbk sel menu).  
The speed reference destination choice must be done according to the speed regulator configuration (e.g. can not use **Speed ref 1** with the ramp active).
- Encoder 1 type** It defines the encoder type to the XE1 connector connected.  
Sinusoidal Sinusoidal encoder  
Digital Digital encoder (DES option required)
- Encoder 1 pulses** Pulse number of the encoder to the XE1 connector connected.
- Encoder 2 pulses** Pulse number of the encoder to the XE2 connector connected.
- Refresh enc 1** Enables the monitoring of the encoder 1 connection status, in order to detect a speed feedback loss alarm
- Refresh enc 2** Enables the monitoring of the digital encoder 2 connection status, in order to detect a speed feedback loss alarm

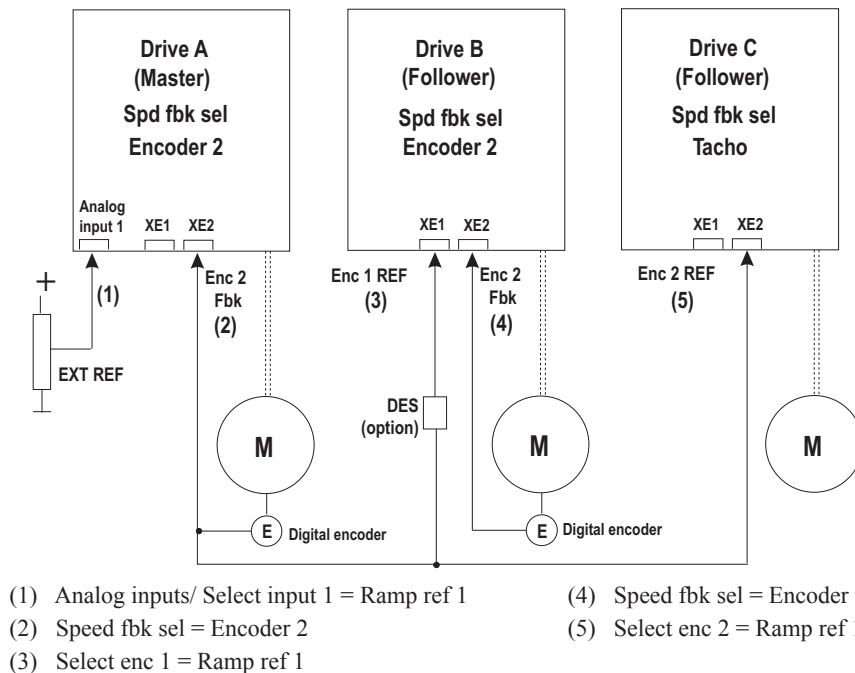

Figure 6.12.5.2: Example of application of the encoder reference

The Drive A speed reference is provided in this case by an external analog signal but it could be set from internal digital sources (e.g. APC200 optional card or field bus).

A configuration using the encoder signal as the line speed reference, is only possible when the speed reference source is provided by an additional encoder, independent from the motor shaft.

## 6.13 ADDITIONAL SPEED FUNCTIONS (ADD SPEED FUNCT)

### 6.13.1 Auto capture

| ADD SPEED FUNCT |              |
|-----------------|--------------|
| [388]           | Auto capture |

The auto capture function enables the converter to engage a running motor.

| Parameter description                    | No. | Value |     |                  |                  | Standard Configuration |
|--|-----|-------|-----|------------------|------------------|------------------------|
|  |     | min   | max | Factory American | Factory European |                        |
| <b>Auto capture</b><br>ON (1)<br>OFF (0) | 388 |       |     | OFF (0)          | OFF (0)          | *                      |

\* This function can be assigned to one of the programmable digital inputs.

|                     |     |   |
|---------------------|-----|---|
| <b>Auto capture</b> | ON  | When the converter is switched on, the speed of the motor is measured and the ramp output is set accordingly. The drive then runs to the set reference value. |
|                     | OFF | When the converter is switched on, the ramp starts from zero.   |

Main uses: Connection to a motor that is already running due to its load (e.g. in the case of pumps, the flowing medium).  
Reconnection after a fault alarm.

If the speed reference value is defined via the ramp, with **Auto capture** = ON, starting at a reference value corresponding to the motor speed.

**Note!** If the function is switched off, ensure that the motor is not turning when the converter is switched on. If this is not the case, this may cause a harsh motor deceleration in current limit.

### 6.13.2 Adaptive spd reg

| ADD SPEED FUNCT |                   |                     |
|-----------------|-------------------|---------------------|
|                 | Adaptive spd reg  |                     |
|                 | [181]             | Enable spd adap     |
|                 | [182]             | Select adap type    |
|                 | [183]             | Adap reference [FF] |
|                 | [1464]            | Adap selector       |
|                 | [184]             | Adap speed 1 [%]    |
|                 | [185]             | Adap speed 2 [%]    |
|                 | [186]             | Adap joint 1 [%]    |
|                 | [187]             | Adap joint 2 [%]    |
|                 | [188]             | Adap P gain 1 [%]   |
|                 | [189]             | Adap I gain 1 [%]   |
|                 | [190]             | Adap P gain 2 [%]   |
|                 | [191]             | Adap I gain 2 [%]   |
|                 | [192]             | Adap P gain 3 [%]   |
|                 | [193]             | Adap I gain 3 [%]   |
|                 | [1462]            | Adap P gain 4 [%]   |
| [1463]          | Adap I gain 4 [%] |                     |

The adaptive speed regulator function enables different gains of the speed regulator depending on the speed or another variable (Adaptive Reference). This allows optimum adaptation of the speed regulator to the application at hand.

| Parameter description   | No.  | Value  |        |                  |                  | Standard Configuration |
|---|------|--------|--------|------------------|------------------|------------------------|
|   |      | min    | max    | Factory American | Factory European |                        |
| <b>Enable spd adap</b><br>Enabled (1)<br>Disabled (0)                       | 181  | 0      | 1      | Disabled         | Disabled         | -                      |
| <b>Select adap type</b><br>Speed (0)<br>Adap reference (1)<br>Parameter (2) | 182  | 0      | 2      | Speed            | Speed            | -                      |
| <b>Adap reference [FF]</b>  | 183  | -32768 | +32767 | 1000             | 1000             | *                      |
| <b>Adap selector</b>  | 1464 | 0      | 3      | 0                | 0                | -                      |
| <b>Adap speed 1 [%]</b>   | 184  | 0.0    | 200.0  | 20.3             | 20.3             | -                      |
| <b>Adap speed 2 [%]</b>   | 185  | 0.0    | 200.0  | 40.7             | 40.7             | -                      |
| <b>Adap joint 1 [%]</b>   | 186  | 0.0    | 200.0  | 6.1              | 6.1              | -                      |
| <b>Adap joint 2 [%]</b>   | 187  | 0.0    | 200.0  | 6.1              | 6.1              | -                      |
| <b>Adap P gain 1 [%]</b>  | 188  | 0.00   | 100.00 | 10.00            | 10.00            | -                      |
| <b>Adap I gain 1 [%]</b>  | 189  | 0.00   | 100.00 | 1.00             | 1.00             | -                      |
| <b>Adap P gain 2 [%]</b>  | 190  | 0.00   | 100.00 | 10.00            | 10.00            | -                      |
| <b>Adap I gain 2 [%]</b>  | 191  | 0.00   | 100.00 | 1.00             | 1.00             | -                      |
| <b>Adap P gain 3 [%]</b>  | 192  | 0.00   | 100.00 | 10.00            | 10.00            | -                      |
| <b>Adap I gain 3 [%]</b>  | 193  | 0.00   | 100.00 | 1.00             | 1.00             | -                      |
| <b>Adap P gain 4 [%]</b>  | 1462 | 0.00   | 100.00 | 10.00            | 10.00            | -                      |
| <b>Adap I gain 4 [%]</b>  | 1463 | 0.00   | 100.00 | 1.00             | 1.00             | -                      |

\* This function can be assigned to one of the programmable analog inputs.

|                         |   |   |
|-------------------------|---|---|
| <b>Enable spd adap</b>  | Enabled<br>Disabled   | Adaptive speed regulation enabled.<br>Adaptive speed regulation is not enabled. The regulator operates with the parameters set in the REG PARAMETERS menu.  |
| <b>Select adap type</b> | Speed<br>Adap reference<br>Parameter  | The regulator parameters are modified according to the speed.<br>The regulator parameters are modified according to the <b>Adap reference</b> parameter.<br>It allows to change the gains via parameter or via dual digital input. Only in these operating conditions are 4 sets of PI gains available. |
| <b>Adap reference</b>   | The variable according to which the speed regulator parameters are to be modified (only with <b>Select adap type</b> = Adap reference).   |   |
| <b>Adap selector</b>    | The Adap selector parameter selects a pair of parameters: <b>Adap P gain</b> and <b>Adap I gain</b> from 1 to 4, if Sel adap type is set to Parameter. If the Adap selector parameter is programmed on digital inputs <b>Adapt Sel 1</b> or <b>Adapt Sel 2</b> , it only indicates which pair of gains has been selected. |   |
| <b>Adap speed 1</b>     | Parameter set 1 is valid below this point, and parameter set 2 above it. The transition behaviour between the values is defined by the <b>Adap joint 1</b> parameter. The definition is a percentage of the <b>Speed base value</b> and the maximum value of <b>Adap reference</b> .                                      |   |
| <b>Adap speed 2</b>     | Parameter set 2 is valid below this point, and parameter set 3 above it. The transition behaviour between the values is defined by <b>Adap joint 2</b> . The definition is a percentage of the <b>Speed base value</b> and the maximum value of <b>Adap reference</b> .   |   |
| <b>Adap joint 1</b>     | Defines a range around <b>Adap speed 1</b> in which there is a linear change in gain from parameter set 1 to parameter set 2 in order to prevent jumps in the behavior of the regulator. It is defined as a percentage of <b>Speed base value</b> .   |   |
| <b>Adap joint 2</b>     | Defines a range around <b>Adap Speed 2</b> in which there is a linear change in gain from parameter set 2 to parameter set 3 in order to prevent jumps in the behavior of the regulator. It is defined as a percentage of <b>Speed base value</b> .   |   |
| <b>Adap P gain 1</b>    | Proportional gain for the range from zero to <b>Adap speed 1</b> . Defined as a percentage of <b>Speed P base</b> .   |   |

|                      |  |
|----------------------|--|
| <b>Adap I gain 1</b> | Integral gain for the range from zero to Adap speed 1. Defined as a percentage of <b>Speed I base</b> .                            |
| <b>Adap P gain 2</b> | Proportional gain for the range from <b>Adap speed 1</b> to <b>Adap speed 2</b> . Defined as a percentage of <b>Speed P base</b> . |
| <b>Adap I gain 2</b> | Integral gain for the range from <b>Adap speed 1</b> to <b>Adap speed 2</b> . Defined as a percentage of <b>Speed I base</b> .     |
| <b>Adap P gain 3</b> | Proportional gain for the range above <b>Adap speed 2</b> . Defined as a percentage of <b>Speed P base</b> .                       |
| <b>Adap I gain 3</b> | Integral gain for the range above <b>Adap speed 2</b> . Defined as a percentage of <b>Speed I base</b> .                           |
| <b>Adap P gain 4</b> | Proportional gain for the range above <b>Adap speed 3</b> . Defined as a percentage of <b>Speed P base</b> .                       |
| <b>Adap I gain 4</b> | Integral gain for the range above <b>Adap speed 3</b> . Defined as a percentage of <b>Speed I base</b> .                           |

In order to activate Adaptive speed regulation, the function must be enabled with the **Enable spd adap** parameter. Normally the gain depends on the speed of the drive. It can, however, also vary according to another variable, defined by the **Adap reference** parameter. This must be selected with the **Select adap type** parameter.

The **Adap speed 1** and **Adap speed 2** parameters are used to define the three ranges that may have different gains. A parameter set can be defined for each of these ranges, with each set containing an individually definable P and I component.

The **Adap joint 1** and **Adap joint 2** parameters ensure a smooth transition between the different parameter sets. The fields must be defined so that **Adap joint 1** and **Adap joint 2** do not overlap.

When the Adaptive speed regulation is enabled (**Enable spd adap** = Enabled) the **Speed P** and **Speed I** parameters have no effect. They still retain their value and are effective after any disabling of the adaptive speed regulation.

When the drive is not enabled, the gain of the speed regulator is determined by the zero speed logic. See section 6.7.2, “Zero speed logic”.

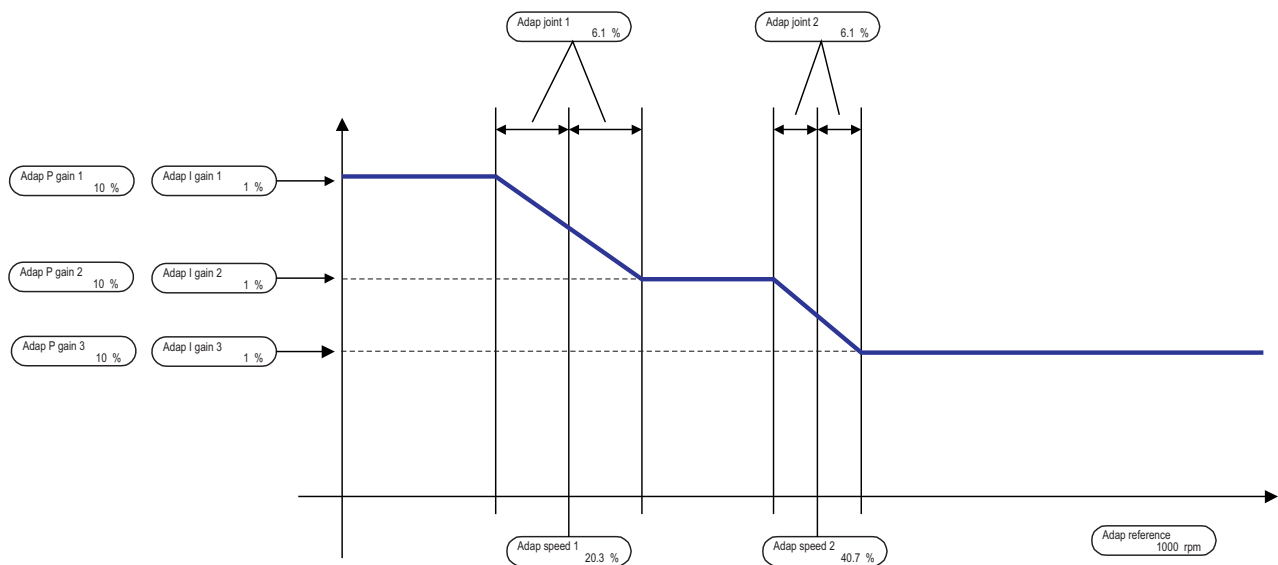

Figure 6.13.2.1: Adaptive of the speed regulator

### 6.13.3 Speed control

| ADD SPEED FUNCT |               |                      |
|-----------------|---------------|----------------------|
|                 | Speed control |                      |
|                 | [101]         | Spd threshold + [FF] |
|                 | [102]         | Spd threshold - [FF] |
|                 | [103]         | Threshold delay [ms] |
|                 | [104]         | Set error [FF]       |
|                 | [105]         | Set delay [ms]       |

Two speed control messages are provided:

- when a particular, adjustable speed is not exceeded.
- when the speed corresponds to the set reference value

| Parameter description  | No. | Value |       |                  |                  | Standard Configuration |
|--|-----|-------|-------|------------------|------------------|------------------------|
|  |     | min   | max   | Factory American | Factory European |                        |
| <b>Spd threshold + [FF]</b>  | 101 | 1     | 32767 | 1000             | 1000             | -                      |
| <b>Spd threshold - [FF]</b>  | 102 | 1     | 32767 | 1000             | 1000             | -                      |
| <b>Threshold delay [ms]</b>  | 103 | 0     | 65535 | 100              | 100              | -                      |
| <b>Spd threshold</b><br>Speed exceeded (0)<br>Speed not exceeded (1) | 393 | 0     | 1     |                  |                  | Digital output 3 *     |
| <b>Set error [FF]</b>  | 104 | 1     | 32767 | 100              | 100              | -                      |
| <b>Set delay [ms]</b>  | 105 | 1     | 65535 | 100              | 100              | -                      |
| <b>Set speed</b><br>Speed not ref. val. (0)<br>Speed = ref. val. (1) | 394 | 0     | 1     |                  |                  | -                      |

\* This function can be assigned to a programmable digital output.

|                        |  |
|------------------------|--|
| <b>Spd threshold +</b> | Switch point for the “Speed not exceeded” for clockwise rotation of the drive in the units defined by the Factor function.   |
| <b>Spd threshold -</b> | Switch point for the “Speed not exceeded” for counter-clockwise rotation of the drive in the units defined by the Factor function.   |
| <b>Threshold delay</b> | Setting of a delay time in milliseconds which is active when the speed is lowered within the limits of the set threshold.  |
| <b>Spd threshold</b>   | Message “Set speed not exceeded” (via a programmable digital input)<br>High Speed not exceeded<br>Low Speed exceeded   |
| <b>Set error</b>       | Defines a tolerance band around the speed reference in the units specified by the Factor function.   |
| <b>Set delay</b>       | Setting of a delay time in milliseconds which is active when the speed is lowered within the limits of the set threshold.  |
| <b>Set speed</b>       | Message “The speed corresponds to the reference value” (via a programmable digital output)<br>High Speed corresponds to the reference value<br>Low Speed does not corresponds to the reference value |

The message “The speed corresponds to the reference value” refers to the total reference value in front of the **Speed ref** speed regulator and to the **Ramp Ref** ramp reference when the ramp is selected.

When the references are lower than  $\pm 1\%$ , the signal is always low!

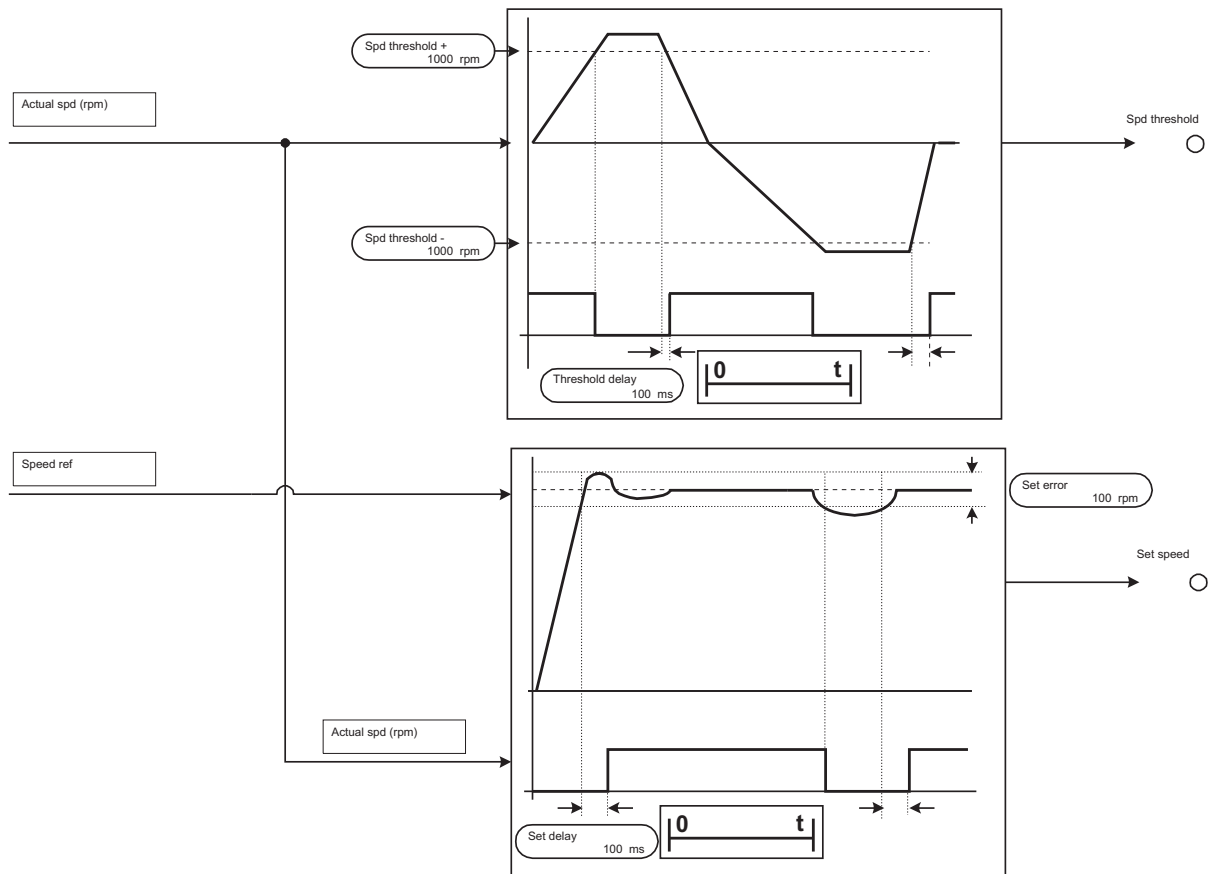

Figure 6.13.3.1: "Speed threshold" (up) and "Set speed" (down) messages

### 6.13.4 Speed zero

#### ADD SPEED FUNCT

#### Speed zero

|       |                       |
|-------|-----------------------|
| [107] | Speed zero level [FF] |
| [108] | Speed zero delay [ms] |

| Parameter description  | No. | Value |       |                  |                  | Standard Configuration |
|--|-----|-------|-------|------------------|------------------|------------------------|
|  |     | min   | max   | Factory American | Factory European |                        |
| Speed zero level [FF]  | 107 | 1     | 32767 | 10               | 10               | -                      |
| Speed zero delay [ms]  | 108 | 0     | 65535 | 100              | 100              | -                      |
| Speed zero thr<br>Drive not rotating (0)<br>Drive rotating (1) | 395 | 0     | 1     |                  |                  | *                      |

\* This function can be assigned to a programmable digital output.

**Speed zero level** Switch threshold for **Speed zero level**. The value applies to both rotation directions for the TPD32...4B converters. Defined by the units specified in the factor function.

**Speed zero delay** Definition of a delay time in milliseconds, when the zero speed is reached.

**Speed zero thr** "Speed zero thr" message "Drive turning" (via a programmable digital output).

High Drive turning

Low Drive not turning

The LED “Zero Speed” is lit when the drive is not turning.

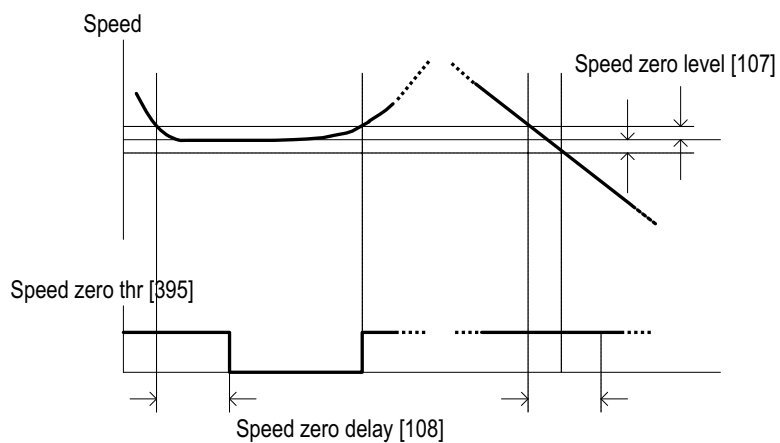

Figure 6.13.4.1: Speed zero



## 6.14 FUNCTIONS

### 6.14.1 Motorpotentiometer

| FUNCTIONS |                  |
|-----------|------------------|
|           | <b>Motor pot</b> |
| [246]     | Enable motor pot |
| [247]     | Motor pot oper   |
| [248]     | Motor pot sign   |
| [249]     | Motor pot reset  |

The motor potentiometer function allows the speed of the drive to be adjusted by pressing a key. The speed is then adjusted according to the defied ramp time.

| Parameter description  | No. | Value |     |                  |                  | Standard Configuration |
|--|-----|-------|-----|------------------|------------------|------------------------|
|  |     | min   | max | Factory American | Factory European |                        |
| <b>Enable motor pot</b><br>Enabled (1) / Disabled (0)            | 246 | 0     | 1   | Disabled         | Disabled         | -                      |
| <b>Motor pot oper</b>  | 247 |       |     |                  |                  | -                      |
| <b>Motor pot sign</b><br>Positive (1) / Negative (0)             | 248 | 0     | 1   | Positive         | Positive         | -                      |
| <b>Motor pot sign +</b>  | -   |       |     |                  |                  | **                     |
| <b>Motor pot sign -</b>  | -   |       |     |                  |                  | **                     |
| <b>Motor pot reset</b>   | 249 |       |     |                  |                  | *                      |
| <b>Motor pot up</b><br>No acceleration (0)<br>Acceleration (1)   | 396 | 0     | 1   |                  |                  | *                      |
| <b>Motor pot down</b><br>No deceleration (0)<br>Deceleration (1) | 397 | 0     | 1   |                  |                  | *                      |

\* This function can be assigned to one of the programmable digital inputs.

\*\* This parameter can be assigned to a programmable analog output.

**Enable motor pot**      Enabled      The motor potentiometer function is enabled. The ramp receives its reference value from the motor potentiometer function.  
    Disabled      The reference value potentiometer function is disabled.

**Motor pot oper**      By pressing the “+” and “-” keys of the keypad the drive can be accelerated or decelerated.  
    +      Accelerate      -      Decelerate

**Motor pot sign**      This parameter is only accessible via the keypad and via the serial interface or Bus. When the drive is operated via the terminal strip, the parameters **Motor pot sign +** and **Motor pot sign -** must be used. As for TPD32...2B... converters the “Positive” function must be selected.

Positive      “Clockwise” rotation selected  
 Negative      “Counterclockwise” rotation selected

**Motor pot sign +**      Only for TPD32...4B...! Selection of the “Clockwise” rotation direction when the selection is carried out via the terminal strip. The **Motor pot sign +** parameter is linked with the **Motor pot sign -** parameter via an XOR function. This means that the command (+24V) must be given only to one of the two terminals.

High      “Clockwise” rotation direction selected  
 Low      “Clockwise” rotation direction not selected

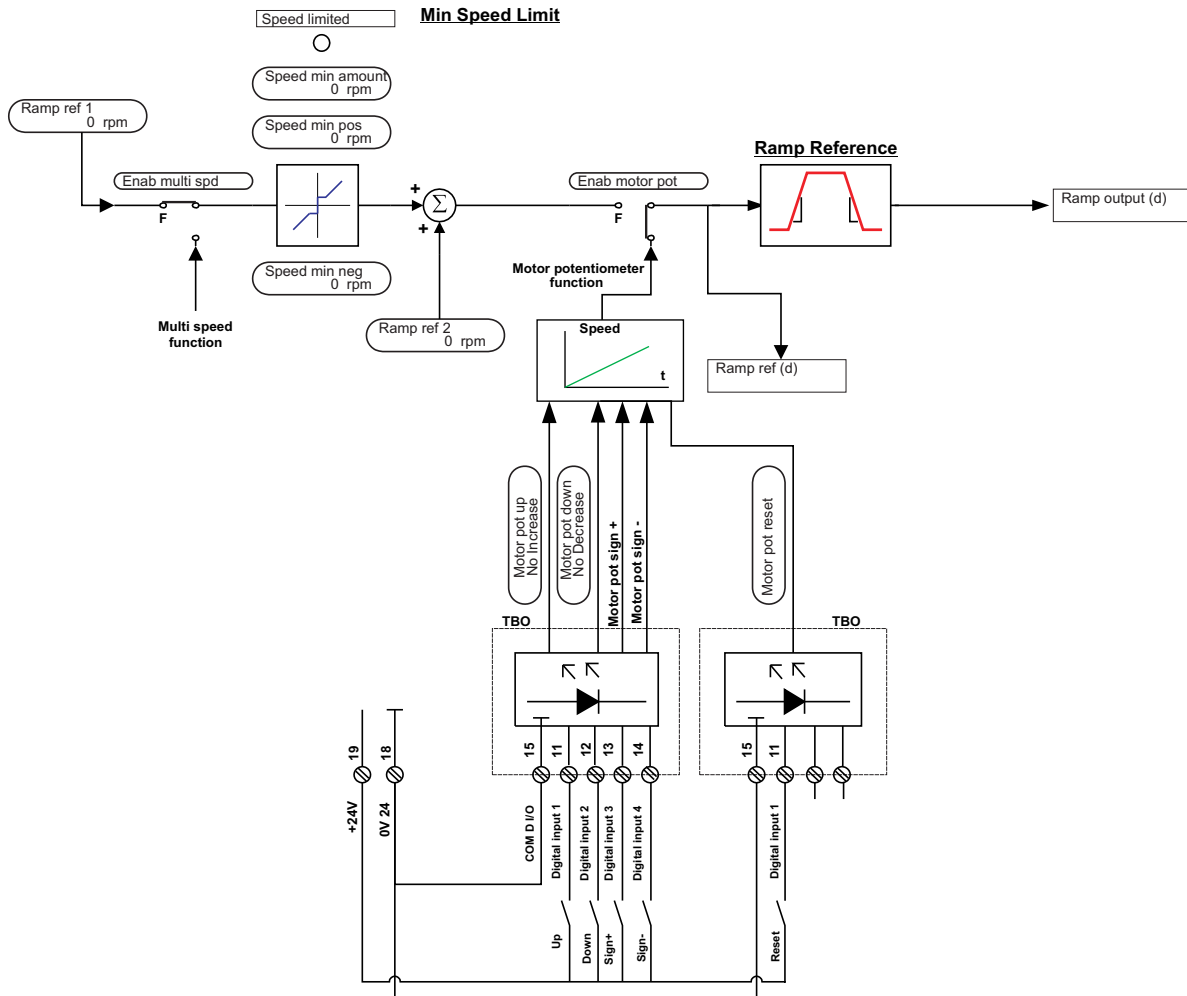

Figure 6.14.1.1: Motor potentiometer

#### Motor pot sign -

Only for TPD32...4B...! Selection of the “Counterclockwise” rotation when the changeover is carried out via the terminal strip. The **Motor pot sign -** parameter is linked with the **Motor pot sign +** parameter via an XOR function. This means that the command (+24V) must be given only to one of the two terminals.  
 High ”Counter-clockwise” rotation direction selected.  
 Low ”Counter-clockwise” rotation direction not selected.

#### Motor pot reset.

When the Reset command is activated and the drive is switched off, the restart begins at “Zero” speed. The command is only possible with the drive switched off!

#### Motor pot up

The drive is accelerated with the preselected ramp. The setting is either carried out via the terminal, serial interface or Bus.

#### Motor pot down

The drive is decelerated with the preselected ramp. The setting is either carried out via the terminal, serial interface or Bus.

When the motor potentiometer function is active (**Enable motor pot**), the current speed reference value is shown in the **Motor pot** submenu of the keypad. When controlled via the keypad, the drive can be accelerated by pressing the “+” key and decelerated by pressing the “-” key. This corresponds to the commands **Motor pot up** and **Motor pot down**. Select the menu point **Motor pot oper** for this purpose.

The speed of the drive can be adjusted between 0 to 100 % by setting the command **Motor pot up**. The drive reduces the speed between 100 and 0 % by setting the command **Motor pot down**. If the command is given when the drive is already at a stop, it will not cause the reverse running of the drive.

If the **Motor pot up** and **Motor pot down** commands are given at the same time, they will not change the speed reference value. The last speed reference value is saved when the drive is switched off or if there is a fault. When the drive is restarted, it accelerates to this speed according to the ramp set. If the command **Motor pot reset** is given with the drive switched off, the speed reference value is deleted and the drive starts at zero speed. If the status of the **Motor pot sign** command is changed while the drive is running, the drive will reverse according to the specified ramp times.

When using the motor potentiometer function, the ramp must be enabled and the **Start** command must be present.

## 6.14.2 Jog function

| FUNCTIONS |                     |
|-----------|---------------------|
|           | <b>Jog function</b> |
| [244]     | Enable jog          |
| [265]     | Jog operation       |
| [375]     | Jog selection       |
| [266]     | Jog reference [FF]  |

| Parameter description                                     | No. | Value |       |                  |                  | Standard Configuration |
|---|-----|-------|-------|------------------|------------------|------------------------|
|   |     | min   | max   | Factory American | Factory European |                        |
| <b>Enable jog</b><br>Enabled (1) / Disabled (0)           | 244 | 0     | 1     | Disabled         | Disabled         | -                      |
| <b>Jog operation</b>                                      | 265 | -     | -     | -                | -                |                        |
| <b>Jog selection</b><br>Speed input (0) / Ramp input (1)  | 375 | 0     | 1     | 0                | 0                | -                      |
| <b>Jog reference [FF]</b>                                 | 266 | 0     | 32767 | 0                | 0                | **                     |
| <b>Jog +</b><br>No jog forwards (0)<br>Forwards jog (1)   | 398 | 0     | 1     |                  |                  | *                      |
| <b>Jog -</b><br>No backwards jog (0)<br>Backwards jog (1) | 399 | 0     | 1     |                  |                  | *                      |

\* This function can be assigned to one of the programmable digital inputs.

\*\* This parameter can be assigned to a programmable analog input.

|                      |  |   |
|----------------------|--|---|
| <b>Enable jog</b>    | Enabled  | Enabled Jog function (this selection is possible only when the drive is switched off).  |
|                      | Disabled   | Disabled Jog function   |
| <b>Jog operation</b> | Pressing the “+” and “-” keys on the keypad enables the drive to be moved forward and backward. In connection with the TPD32...4B converters it is possible to operate the Jog function in an anti-clockwise rotation by pressing the “-” key. |   |
|                      | +  | Jog clockwise rotation  |
|                      | -  | Jog counter-clockwise rotation  |
| <b>Jog reference</b> | Reference value for jog mode. Defined by the units, specified by the factor function.  |   |
| <b>Jog selection</b> | This parameter determines if the Jog function reference must go through the ramp or directly to the speed regulator.   |   |
|                      | Speed input  | The Jog reference is directly defined. The ramp is not active.  |
|                      | Ramp input   | The Jog reference is defined with a set ramp.   |
| <b>Jog +</b>         | High   | Clockwise Jog function when the Jog function is enabled and the <b>Start</b> command is not present.                            |
|                      | Low  | Disabled  |
| <b>Jog -</b>         | High   | Counter-clockwise Jog function for the TPD32...4B when the Jog function is enabled and the <b>Start</b> command is not present. |

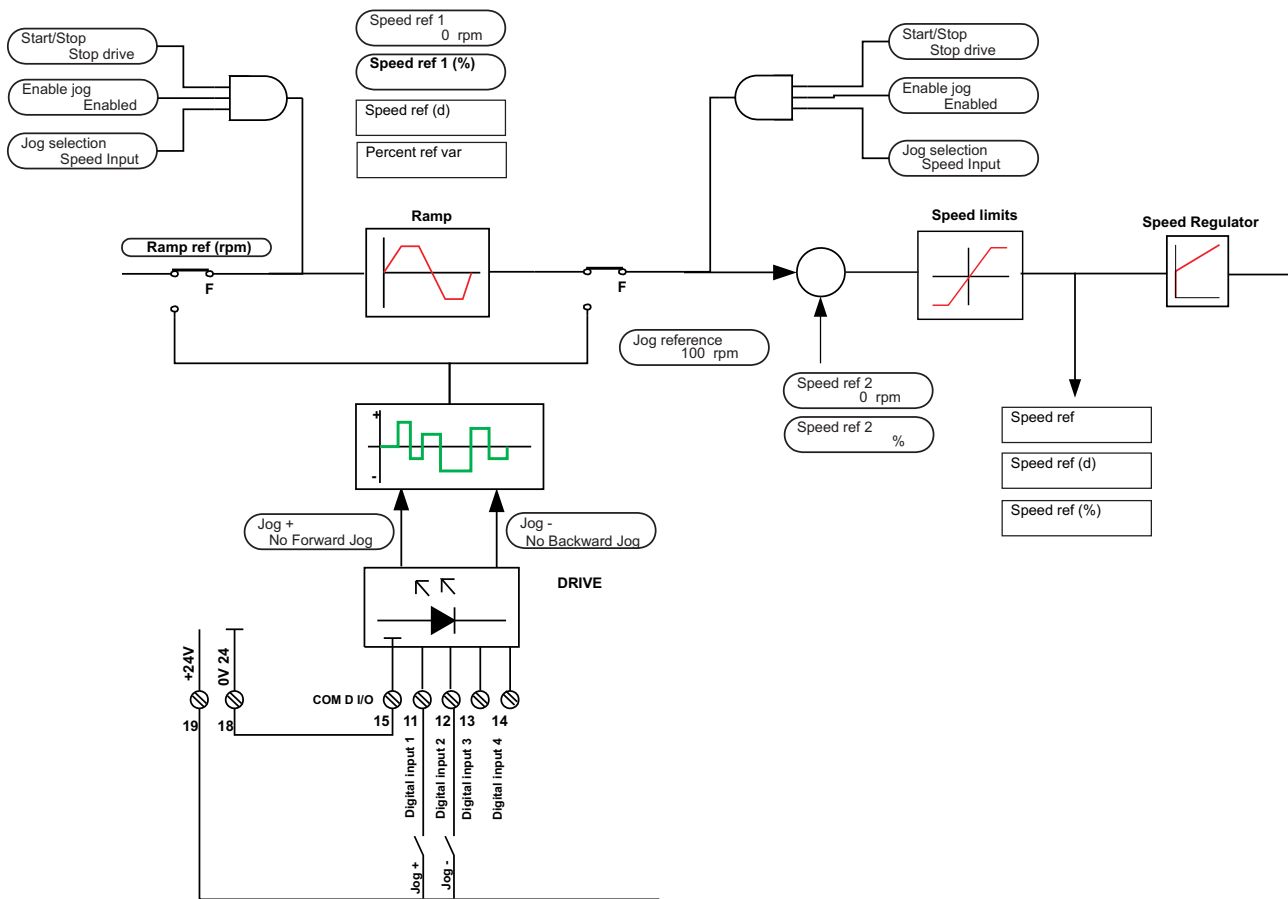

Figure 6.14.2.1: Example of external activation in Jog mode

**Note!** The following signals are required for Jog mode in addition to the commands **Jog +** and **Jog -** :  
**Enable drive**      **Fast Stop**      **External fault**      Low      Disabled

The jog speed corresponds to the value which is defined by the **Jog reference** parameter. In this case no ramp is used.

The jog reference value can only be activated by the **Jog +** or **Jog -** command if there is no **Start** command active.

If the **Start** command is given in addition to the **Jog +** and **Jog -** command, Jog mode will be aborted and the drive will react according to the Start command.

When controlled via the keypad the “+” and “-” keys can be used in the Jog function menu. (only for TPD32...4B...). For this select the **Jog operation** menu point.

The correction value **Speed ref 2** for the speed regulator is also active in jog operation.

**Note!** If the **Stop control** function is activated, to enable the Jog function the **Jog Stop control** (FUNCTION/Stop control) must also be set to ON (1).

### 6.14.3 Multi speed function

| FUNCTIONS |                        |
|-----------|------------------------|
|           | <b>Multi speed fct</b> |
| [153]     | Enab multi spd         |
| [154]     | Multi speed 1 [FF]     |
| [155]     | Multi speed 2 [FF]     |
| [156]     | Multi speed 3 [FF]     |
| [157]     | Multi speed 4 [FF]     |
| [158]     | Multi speed 5 [FF]     |
| [159]     | Multi speed 6 [FF]     |
| [160]     | Multi speed 7 [FF]     |
| [208]     | Multispeed sel         |

The Multi speed function allows up to seven internally saved reference values to be called up via a digital signal.

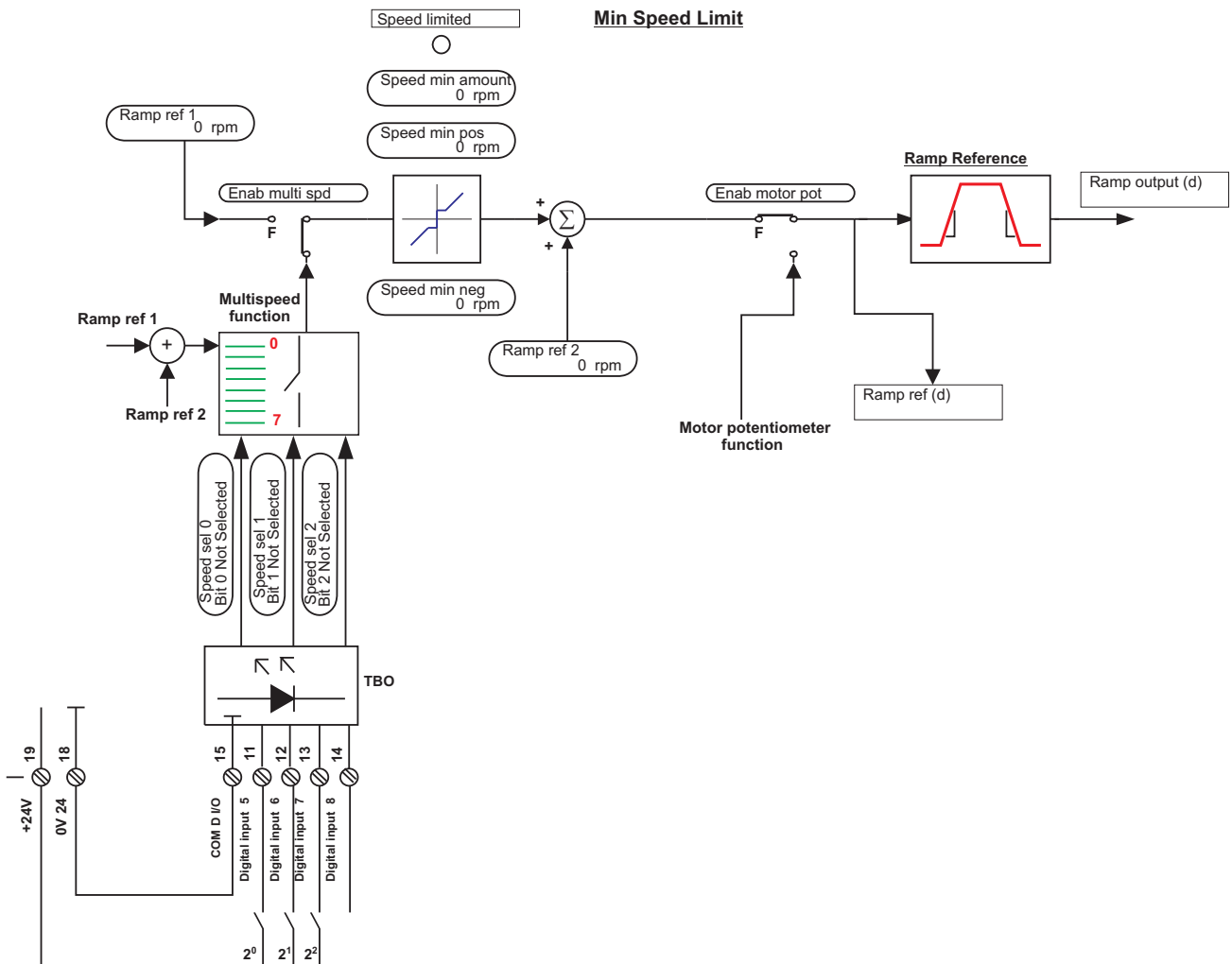

Figure 6.14.3.1: Selection of different references via terminals

| Parameter description  | No. | Value  |        |                  |                  | Standard Configuration |
|--|-----|--------|--------|------------------|------------------|------------------------|
|  |     | min    | max    | Factory American | Factory European |                        |
| Enab multi spd<br>Enabled (1)<br>Disabled (0)  | 153 | 0      | 1      | Disabled         | Disabled         |                        |
| <b>Multi speed 1 [FF]</b>  | 154 | -32768 | +32767 | 0                | 0                | -                      |
| <b>Multi speed 2 [FF]</b>  | 155 | -32768 | +32767 | 0                | 0                | -                      |
| <b>Multi speed 3 [FF]</b>  | 156 | -32768 | +32767 | 0                | 0                | -                      |
| <b>Multi speed 4 [FF]</b>  | 157 | -32768 | +32767 | 0                | 0                | -                      |
| <b>Multi speed 5 [FF]</b>  | 158 | -32768 | +32767 | 0                | 0                | -                      |
| <b>Multi speed 6 [FF]</b>  | 159 | -32768 | +32767 | 0                | 0                | -                      |
| <b>Multi speed 7 [FF]</b>  | 160 | -32768 | +32767 | 0                | 0                | -                      |
| <b>Speed sel 0</b><br>Value 2 <sup>0</sup> not selected (0)<br>Value 2 <sup>0</sup> selected (1) | 400 | 0      | 1      | 0                | 0                | Digital inp 5 *        |
| <b>Speed sel 1</b><br>Value 2 <sup>1</sup> not selected (0)<br>Value 2 <sup>1</sup> selected (1) | 401 | 0      | 1      | 0                | 0                | Digital inp 6 *        |
| <b>Speed sel 2</b><br>Value 2 <sup>2</sup> not selected (0)<br>Value 2 <sup>2</sup> selected (1) | 402 | 0      | 1      | 0                | 0                | Digital inp 7 *        |
| <b>Multispeed sel</b>  | 208 | 0      | 7      | 0                | 0                |                        |

\* This function can be assigned to one of the programmable digital inputs.

|                       |  |   |
|-----------------------|--|---|
| <b>Enab multi spd</b> | Enabled<br>Disabled  | Enabled multi speed function<br>Disabled multi speed function |
| <b>Multi speed 1</b>  | Reference value 1 for enabled multi speed function. Defined by the units specified in the factor function  |   |
| <b>Multi speed 2</b>  | Reference value 2 for enabled multi speed function. Defined by the units specified in the factor function  |   |
| <b>Multi speed 3</b>  | Reference value 3 for enabled multi speed function. Defined by the units specified in the factor function  |   |
| <b>Multi speed 4</b>  | Reference value 4 for enabled multi speed function. Defined by the units specified in the factor function  |   |
| <b>Multi speed 5</b>  | Reference value 5 for enabled multi speed function. Defined by the units specified in the factor function  |   |
| <b>Multi speed 6</b>  | Reference value 6 for enabled multi speed function. Defined by the units specified in the factor function  |   |
| <b>Multi speed 7</b>  | Reference value 7 for enabled multi speed function. Defined by the units specified in the factor function  |   |
| <b>Speed sel 0</b>    | Reference value selection with the significance 2 <sup>0</sup> (=1) (Bit 0). Parameter can only be used in conjunction with <b>Speed sel 1</b> and <b>Speed sel 2</b> .<br>High                      Significance 2 <sup>0</sup> selected<br>Low                        Significance 2 <sup>0</sup> not selected |   |
| <b>Speed sel 1</b>    | Reference value selection with the significance 2 <sup>1</sup> (=2) (Bit 1). Parameter can only be used in conjunction with <b>Speed sel 0</b> and <b>Speed sel 2</b> .<br>High                      Significance 2 <sup>1</sup> selected<br>Low                        Significance 2 <sup>1</sup> not selected |   |
| <b>Speed sel 2</b>    | Reference value selection with the significance 2 <sup>2</sup> (=4) (Bit 2). Parameter can only be used in conjunction with <b>Speed sel 0</b> and <b>Speed sel 1</b> .<br>High                      Significance 2 <sup>2</sup> selected<br>Low                        Significance 2 <sup>2</sup> not selected |   |

## Multi speed sel

It is the word representation of the three parameters **Speed sel 1** (bit0), **Speed sel 2** (bit1) and **Speed sel 3** (bit2). Used to change the speed selection by changing only one parameter instead of three. This allows selecting different speeds via serial line or Bus instantaneously.

The table and graph below show the interaction between the selection and the corresponding reference value.

| Speed sel 0<br>Bit 0 Not Selected | Speed sel 1<br>Bit 1 Not Selected | Speed sel 2<br>Bit 2 Not Selected | REFERENCE                           |
|-----------------------------------|-----------------------------------|-----------------------------------|-------------------------------------|
| 0                                 | 0                                 | 0                                 | Ramp ref 1 0 rpm + Ramp ref 2 0 rpm |
| 1                                 | 0                                 | 0                                 | Multi speed 1 0 rpm                 |
| 0                                 | 1                                 | 0                                 | Multi speed 2 0 rpm                 |
| 1                                 | 1                                 | 0                                 | Multi speed 3 0 rpm                 |
| 0                                 | 0                                 | 1                                 | Multi speed 4 0 rpm                 |
| 1                                 | 0                                 | 1                                 | Multi speed 5 0 rpm                 |
| 0                                 | 1                                 | 1                                 | Multi speed 6 0 rpm                 |
| 1                                 | 1                                 | 1                                 | Multi speed 7 0 rpm                 |

Enable multi spd Disabled

Multi speed sel. 0

Ramp ref (d)

Table 6.14.2.1: Multi speed function

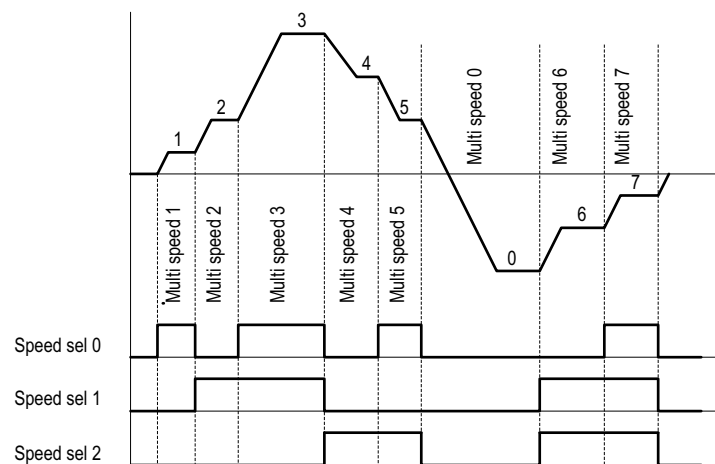

Figure 6.14.3.2: Multi speed function

In order to operate the Multi speed function, it must be enabled with **Enab multi spd** parameter.

The required reference value is selected with the **Speed sel 0**, **Speed sel 1** and **Speed sel 2** signals.

The selection of the reference values is carried out via the keypad or the serial interface.

The reference values are signed so that they can be defined for a particular rotation direction of the drive. As for the TPD32...2B... the reference must have a positive polarity.

When the Multi speed function is enabled, **Multi speed 0** is defined by the addition of the reference values **Ramp ref 1** and **Ramp ref 2**.

## 6.14.4 Multi ramp function

| FUNCTIONS             |                       |                       |
|-----------------------|-----------------------|-----------------------|
|                       | <b>Multi ramp fct</b> |                       |
|                       | [243]                 | Enab multi rmp        |
|                       | [202]                 | Ramp selector         |
|                       | <b>Multi ramp fct</b> |                       |
|                       | <b>Ramp 0</b>         |                       |
|                       | <b>Acceleration 0</b> |                       |
|                       | [659]                 | Acc delta speed0 [FF] |
|                       | [660]                 | Acc delta time 0 [s]  |
|                       | [665]                 | S acc t const 0 [ms]  |
|                       | <b>Deceleration 0</b> |                       |
|                       | [661]                 | Dec delta speed0 [FF] |
|                       | [662]                 | Dec delta time 0 [s]  |
|                       | [666]                 | S dec t const 0 [ms]  |
|                       | <b>Ramp 1</b>         |                       |
|                       | <b>Acceleration 1</b> |                       |
| [23]                  | Acc delta speed1 [FF] |                       |
| [24]                  | Acc delta time 1 [s]  |                       |
| [667]                 | S acc t const 1 [ms]  |                       |
| <b>Deceleration 1</b> |                       |                       |
| [31]                  | Dec delta speed1 [FF] |                       |
| [32]                  | Dec delta time 1 [s]  |                       |
| [668]                 | S dec t const 1 [ms]  |                       |
| <b>Ramp 2</b>         |                       |                       |
| <b>Acceleration 2</b> |                       |                       |
| [25]                  | Acc delta speed2 [FF] |                       |
| [26]                  | Acc delta time 2 [s]  |                       |
| [669]                 | S acc t const 2 [ms]  |                       |
| <b>Deceleration 2</b> |                       |                       |
| [33]                  | Dec delta speed2 [FF] |                       |
| [34]                  | Dec delta time 2 [s]  |                       |
| [670]                 | S dec t const 2 [ms]  |                       |
| <b>Ramp 3</b>         |                       |                       |
| <b>Acceleration 3</b> |                       |                       |
| [27]                  | Acc delta speed3 [FF] |                       |
| [28]                  | Acc delta time 3 [s]  |                       |
| [671]                 | S acc t const 3 [ms]  |                       |
| <b>Deceleration 3</b> |                       |                       |
| [35]                  | Dec delta speed3 [FF] |                       |
| [36]                  | Dec delta time 3 [s]  |                       |
| [672]                 | S dec t const 3 [ms]  |                       |

The Multi ramp function enables up to four different ramps to be called up. The acceleration and deceleration times can also be defined here separately. The ramps are called up via digital signals.



| Parameter description   | No. | Value |       |                  |                  | Standard Configuration |
|---|-----|-------|-------|------------------|------------------|------------------------|
|   |     | min   | max   | Factory American | Factory European |                        |
| <b>Enab multi rmp</b><br>Enabled (1) / Disabled (0)   | 243 | 0     | 1     | Disabled         | Disabled         | -                      |
| <b>Ramp selector</b>  | 202 | 0     | 3     | 0                | 0                | -                      |
| <b>Acc delta speed0 [FF]</b>  | 659 | 0     | 232-1 | 100              | 100              | -                      |
| <b>Acc delta time 0 [s]</b>   | 660 | 0     | 65535 | 1                | 1                | -                      |
| <b>S acc t const 0 [ms]</b>   | 665 | 100   | 3000  | 300              | 300              | -                      |
| <b>Dec delta speed0 [FF]</b>  | 661 | 0     | 232-1 | 100              | 100              | -                      |
| <b>Dec delta time 0 [s]</b>   | 662 | 0     | 65535 | 1                | 1                | -                      |
| <b>S dec t const 0 [ms]</b>   | 666 | 100   | 3000  | 300              | 300              | -                      |
| <b>Acc delta speed1 [FF]</b>  | 23  | 0     | 232-1 | 100              | 100              | -                      |
| <b>Acc delta time 1 [s]</b>   | 24  | 0     | 65535 | 1                | 1                | -                      |
| <b>S acc t const 1 [ms]</b>   | 667 | 100   | 3000  | 300              | 300              | -                      |
| <b>Dec delta speed1 [FF]</b>  | 31  | 0     | 232-1 | 100              | 100              | -                      |
| <b>Dec delta time 1 [s]</b>   | 32  | 0     | 65535 | 1                | 1                | -                      |
| <b>S dec t const 1 [ms]</b>   | 668 | 100   | 3000  | 300              | 300              | -                      |
| <b>Acc delta speed2 [FF]</b>  | 25  | 0     | 232-1 | 100              | 100              | -                      |
| <b>Acc delta time 2 [s]</b>   | 26  | 0     | 65535 | 1                | 1                | -                      |
| <b>S acc t const 2 [ms]</b>   | 669 | 100   | 3000  | 300              | 300              | -                      |
| <b>Dec delta speed2 [FF]</b>  | 33  | 0     | 232-1 | 100              | 100              | -                      |
| <b>Dec delta time 2 [s]</b>   | 34  | 0     | 65535 | 1                | 1                | -                      |
| <b>S dec t const 2 [ms]</b>   | 670 | 100   | 3000  | 300              | 300              | -                      |
| <b>Acc delta speed3 [FF]</b>  | 27  | 0     | 232-1 | 100              | 100              | -                      |
| <b>Acc delta time 3 [s]</b>   | 28  | 0     | 65535 | 1                | 1                | -                      |
| <b>S acc t const 3 [ms]</b>   | 671 | 100   | 3000  | 300              | 300              | -                      |
| <b>Dec delta speed3 [FF]</b>  | 35  | 0     | 232-1 | 100              | 100              | -                      |
| <b>Dec delta time 3 [s]</b>   | 36  | 0     | 65535 | 1                | 1                | -                      |
| <b>S dec t const 3 [ms]</b>   | 672 | 100   | 3000  | 300              | 300              | -                      |
| <b>Ramp sel 0</b><br>Value 2 <sup>0</sup> not selected (0)<br>Value 2 <sup>0</sup> selected (1) | 403 | 0     | 1     | 0                | 0                | *                      |
| <b>Ramp sel 1</b><br>Value 2 <sup>1</sup> not selected (0)<br>Value 2 <sup>1</sup> selected (1) | 404 | 0     | 1     | 0                | 0                | *                      |

\* This function can be assigned to one of the programmable digital inputs.

|                          |  |   |
|--------------------------|--|---|
| <b>Enab multi rmp</b>    | Enabled<br>Disabled  | The Multi ramp function is enabled<br>The Multi ramp function is disabled |
| <b>Ramp selector</b>     | It is the word representaton of the two parameters <b>Ramp sel 0</b> (bit0) and <b>Ramp sel 1</b> (bit1). Used to change the ramp selection by changing only one parameter instead of two. This allows to select different ramps via serial line or Bus instantaneously. |   |
| <b>Acc delta speed 0</b> | It defines together with <b>Acc delta time 0</b> the acceleration ramp 0. Defined by the units specified in the factor function.   |   |
| <b>Acc delta time 0</b>  | It defines together with <b>Acc delta speed 0</b> the acceleration ramp 0. Defined in seconds.   |   |
| <b>S acc t const 0</b>   | Defines the acceleration curve for S-shape ramp 0. Defined in ms.  |   |
| <b>Dec delta speed0</b>  | It defines together with <b>Dec delta time 0</b> the deceleration ramp 0. Defined by the units specified in the factor function.   |   |
| <b>Dec delta time 0</b>  | It defines together with <b>Acc delta speed 0</b> the acceleration ramp 0. Defined in seconds.   |   |
| <b>S dec t const 0</b>   | Defines the deceleration curve for <b>S-shape ramp 0</b> . Defined in ms.  |   |
| <b>Acc delta speed1</b>  | It defines together with <b>Acc delta time 1</b> the acceleration ramp 1. Defined by the units specified in the factor function.   |   |
| <b>Acc delta time 1</b>  | It defines together with <b>Acc delta speed 1</b> the acceleration ramp 1. Defined in seconds.   |   |
| <b>S acc t const 1</b>   | Defines the acceleration curve for <b>S-shape ramp 1</b> . Defined in ms.  |   |

|                         |   |
|-------------------------|---|
| <b>Dec delta speed1</b> | It defines together with <b>Dec delta time 1</b> the deceleration ramp 1. Defined by the units specified in the factor function.  |
| <b>Dec delta time 1</b> | It defines together with <b>Dec delta speed 1</b> the deceleration ramp 1. Defined in seconds.  |
| <b>S dec t const 1</b>  | Defines the deceleration curve for <b>S-shape ramp 1</b> . Defined in ms.   |
| <b>Acc delta speed2</b> | It defines together with <b>Acc delta time 2</b> the acceleration ramp 2. Defined by the units specified in the factor function.  |
| <b>Acc delta time 2</b> | It defines together with <b>Acc delta speed 2</b> the acceleration ramp 2. Defined in seconds.  |
| <b>S acc t const 2</b>  | Defines the acceleration curve for <b>S-shape ramp 2</b> . Defined in ms.   |
| <b>Dec delta speed2</b> | It defines together with <b>Dec delta time 2</b> the deceleration ramp 2. Defined by the units specified in the factor function.  |
| <b>Dec delta time 2</b> | It defines together with <b>Dec delta speed 2</b> the deceleration ramp 2. Defined in seconds.  |
| <b>S dec t const 2</b>  | Defines the deceleration curve for <b>S-shape ramp 2</b> . Defined in ms.   |
| <b>Acc delta speed3</b> | It defines together with <b>Acc delta time 3</b> the acceleration ramp 3. Defined by the units specified in the factor function.  |
| <b>Acc delta time 3</b> | It defines together with <b>Acc delta speed 3</b> the acceleration ramp 3. Defined in seconds.  |
| <b>S acc t const 3</b>  | Defines the acceleration curve for <b>S-shape ramp 3</b> . Defined in ms.   |
| <b>Dec delta speed3</b> | It defines together with <b>Dec delta time 3</b> the deceleration ramp 3. Defined by the units specified in the factor function.  |
| <b>Dec delta time 3</b> | It defines together with <b>Dec delta speed 3</b> the deceleration ramp 3. Defined in seconds.  |
| <b>S dec t const 3</b>  | Defines the deceleration curve for <b>S-shape ramp 3</b> . Defined in ms.   |
| <b>Ramp sel 0</b>       | Ramp selection with the significance $2^0$ (Bit 0). Parameter can only be used in conjunction with <b>Ramp sel 1</b> .<br>High                      Significance $2^0$ selected<br>Low                        Significance $2^0$ not selected |
| <b>Ramp sel 1</b>       | Ramp selection with the significance $2^1$ (Bit 1). Parameter can only be used in conjunction with <b>Ramp sel 0</b> .<br>High                      Significance $2^1$ selected<br>Low                        Significance $2^1$ not selected |

See in the following table and graph the interaction between the selection and the ramp

|               | <b>Ramp sel 0</b> | <b>Ramp sel 1</b> |
|---------------|-------------------|-------------------|
| <b>Ramp 0</b> | Low               | Low               |
| <b>Ramp 1</b> | High              | Low               |
| <b>Ramp 2</b> | Low               | High              |
| <b>Ramp 3</b> | High              | High              |

GD6242g

*Table 6.14.4.1: Ramp selection*

In order to activate the **Multiramp function**, it must be enabled with the **Enab multi rmp** parameter.

The ramp required is selected via the **Ramp sel 0** and **Ramp sel 1** signals. When the selection is made via the terminal strip, it is possible to select only one digital input. This configuration enables only the ramp time selected. Another ramp can be selected at any time. If this happens during an acceleration or deceleration phase, the reference value will then follow the new ramp. The ramp parameter are defined via the keypad or serial line.

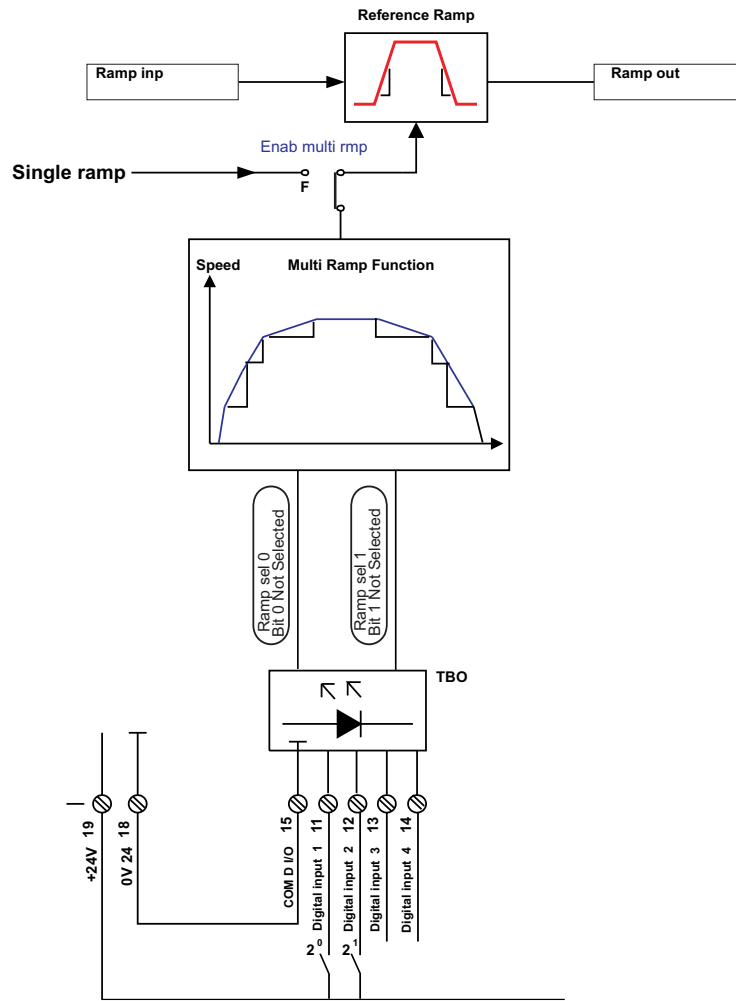

Figure 6.14.4.1: Multi ramp selection via terminals

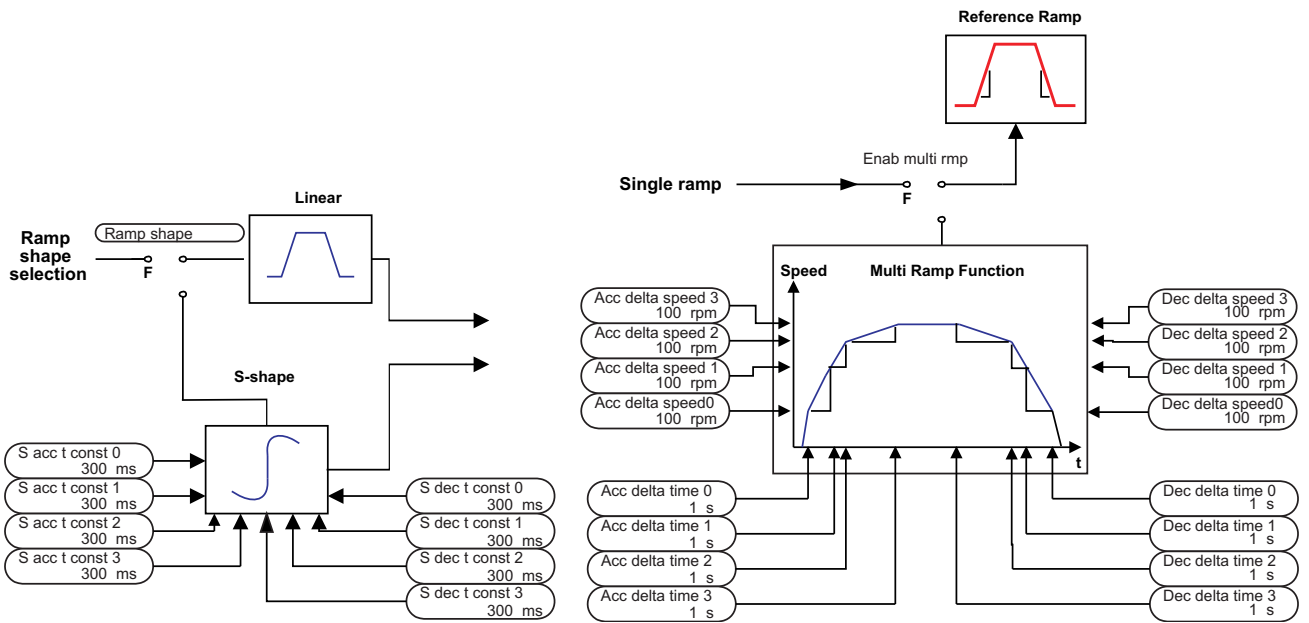

Figure 6.14.4.2: Multi ramp selection via signals

## 6.14.5 Speed Draw function

| FUNCTIONS |                    |
|-----------|--------------------|
|           | Speed draw         |
| [1017]    | Speed ratio        |
| [1018]    | Speed draw out (d) |
| [1019]    | Speed draw out (%) |

| Parameter description | No.  | Value  |        |                  |                  | Standard Configuration |
|-----------------------|------|--------|--------|------------------|------------------|------------------------|
|                       |      | min    | max    | Factory American | Factory European |                        |
| Speed ratio           | 1017 | 0      | +32767 | +10000           | +10000           |                        |
| Speed draw out (d)    | 1018 | -32768 | +32767 | -                | -                |                        |
| Speed draw out (%)    | 1019 | -200.0 | +200.0 | -                | -                |                        |

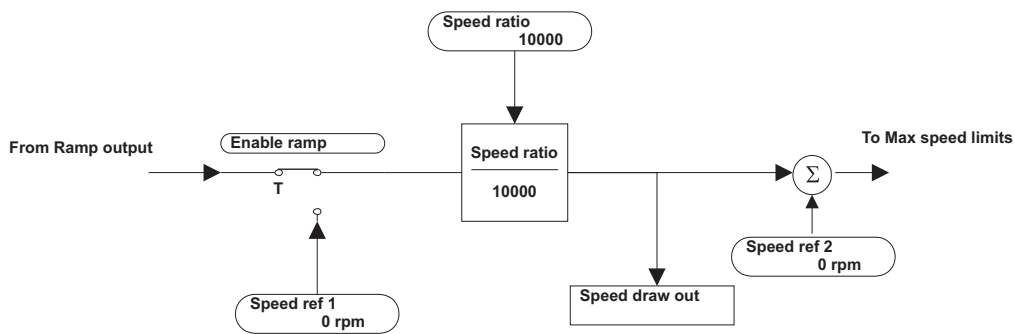

Figure 6.14.5.1: Speed draw block diagram

This function allows a configurable **Speed ratio** to be applied to the main reference **Speed ref 1**.

The Speed ratio range can be set between 0 and 32767 if written in digital form. It can be set from 0 to 20000 (0 to +10V) if assigned via an analog input.

This function is useful in a multidrive system where a **speed ratio** between the motors is required (see example in figure 6.14.5.2).

The speed resulting value can be read through the **Spd draw out** parameter via an analog output.

**Speed ratio** This parameter determines the speed ratio value. This setting can be done in digital form, via LAN or through an analog input.

**Spd draw out (d)** Speed value in the unit specified by the factor function.

**Spd draw out (%)** Speed value as a percentage of **Speed base value**.

## EXAMPLE (RUBBER CALENDER)

### Example Setting:

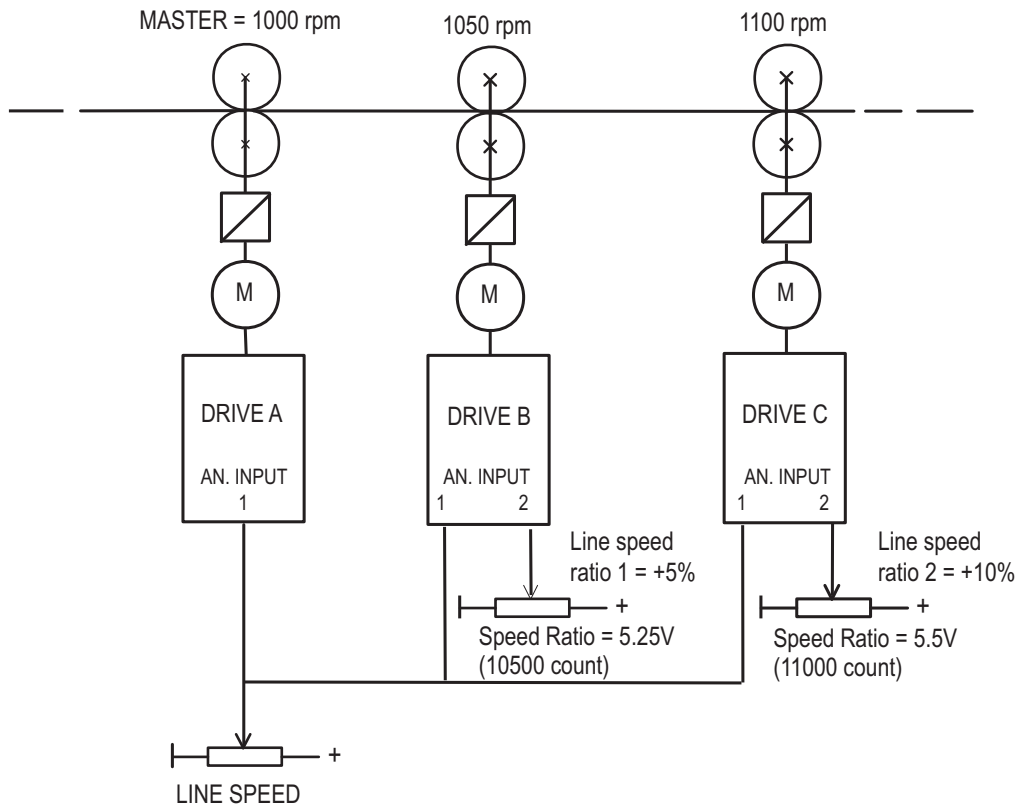

Figure 6.14.5.2: Rubber calender example

#### DRIVE A (master)

Set Analog input 1 = Ramp ref 1

#### DRIVE B

Line speed ratio 1 = Line speed + 5%

Set Analog input 1 = Ramp ref 1

Set Analog input 2 = Speed ratio

Set Speed ratio parameter = 10500

#### DRIVE C

Line speed ratio 2 = Line speed + 10%

Set Analog input 1 = Ramp ref 1

Set Analog input 2 = Speed ratio

Set Speed ratio parameter = 11000

## 6.14.6 Overload control

| FUNCTIONS |                       |                      |
|-----------|-----------------------|----------------------|
|           | <b>Overload contr</b> |                      |
|           | [309]                 | Enable overload      |
|           | [318]                 | Overload mode        |
|           | [312]                 | Overload current [%] |
|           | [313]                 | Base current [%]     |
|           | [310]                 | Overload time [s]    |
|           | [1289]                | Motor ovrlld preal.  |
|           | [655]                 | Motor I2t accum      |
|           | [1438]                | Drive ovrlld preal.  |
|           | [1439]                | Drive I2t accum      |
| [311]     | Pause time [s]        |                      |

| Parameter description   | No.  | Value |            |                        |                  | Standard Configuration |
|---|------|-------|------------|------------------------|------------------|------------------------|
|   |      | min   | max        | Factory American       | Factory European |                        |
| <b>Enable overload</b><br>Enabled (1) / Disabled (0)  | 309  | 0     | 1          | Enabled                | Disabled         | -                      |
| <b>Overload mode</b><br>Curr limited (0)<br>Curr not limited (1)<br>I2t Motor (2)<br>I2t Drive (3)<br>I2t Motor & Drv (4) | 318  | 0     | 4          | I <sup>2</sup> t Motor | Curr limited     | -                      |
| <b>Overload current [%]</b>   | 312  | P313  | 200        | 150                    | 100              |                        |
| <b>Base current [%]</b>   | 313  | 0     | P312 < 100 | 100                    | 80               | -                      |
| <b>Overload time [s]</b>  | 310  | 0     | 65535      | 60                     | 30               | -                      |
| <b>Motor ovrlld preal.</b>  | 1289 | 0     | 1          | -                      | -                |                        |
| <b>Motor I2t accum</b>  | 655  | 0,00  | 100,00     | -                      | -                |                        |
| <b>Drive ovrlld preal.</b>  | 1438 | 0     | 1          | -                      | -                |                        |
| <b>Drive I2t accum</b>  | 1439 | 0,00  | 100,00     | -                      | -                |                        |
| <b>Pause time [s]</b>   | 311  | 0     | 65535      | 540                    | 300              | -                      |
| <b>Overld available</b><br>Overload not possible (0)<br>Overload possible (1)   | 406  | 0     | 1          | -                      | -                | Digital outp.4 *       |
| <b>Overload state</b><br>Current limit value (0)<br>Current > limit value (1)   | 407  | 0     | 1          | -                      | -                | *                      |

\* This parameter can be assigned to a programmable digital output.

The Overload control function allows an overcurrent for a limited time that can also exceed the rated current of the inverter. It is used in order to provide the drive with an increased acceleration torque or for example to allow peak loads, such as with cyclical loads characteristics.

**Enable overload**      Enabled      Overload control is enabled  
                                  Disabled      Overload control is disabled

**Overload mode**      Curr limited      The armature current is restricted to the limits set by the Overload control (size and duration of overcurrent).  
                                  Curr not limited      The armature current is not limited by the Overload control. However, an alarm is possible via the **Overload state** parameter. This alarm indicates whether the current is within the set limits or not.

- I2t Motor
- If **Motor I2t ovrlld** is set to **Activity = Ignore**, the current is reduced from **Overload current** parameter value to **Base current** parameter value when **Motor I2t accum = 100%** (Overload current<sup>2</sup> x Overload time)
  - If **Motor I2t ovrlld** is set to **Activity = Warning**, the current is maintained at **Overload current** parameter value also when **Motor I2t accum = 100%** (Overload current<sup>2</sup> x Overload time)

**NOTE !**

**Motor I2t accum** is equal to 100% if (**Overload current**<sup>2</sup> x **Overload time**) is reached but in any case the limit maximum is [(150% FLC)<sup>2</sup> x 60 sec]

- I2t Drive
- The current is limited to **T current lim (+/-)** value until **Drive I2t accum = 100%** i.e. equal to [(150% Derated Drive Current<sup>(\*)</sup>)<sup>2</sup> x 60 sec]. When this value is reached, the drive is disabled.
- I2t Motor & Drv
- The current is limited to **T current lim (+/-)** value until reaching **Drive I2t accum = 100%** [(150% Derated Drive Current<sup>(\*)</sup>)<sup>2</sup> x 60 sec] if **Motor I2t ovrlld** Activity is set to Warning & Ignore or, If set to Disable drive until reaching **Motor I2t accum = 100%** (Overload current<sup>2</sup> x Overload time).

(\*) Derated Drive Current:

If using the drive with Standard sizes (Size selection = Standard) the Derated Drive Current is calculated as follows:

- Derated Drive Current = Drive size x Derating\_fact (see table below)

If using the drive with American sizes (Size selection = American) the Derated Drive Current is calculated as follows:

- Derated Drive Current = Drive size.

The motor overload function is designed to allow the current selected with **Overload Current** for a time equal to **Overload Time**.

$$(I_{load}^2 - I_{ovld}^2) \cdot t_{s[sec]} = ((Over\ Curr / 100)^2 - 1^2) \cdot I_{Flc}^2 \cdot (Overload\ time)$$

I flc = full load current

The motor overload function gives the possibility to have 1.5 the **Overload current** for 60 sec.

If the threshold is higher than the value is limited to:

$$(I_{load}^2 - I_{Flc}^2) \cdot t_{s[sec]} = (1.5^2 - 1^2) \cdot I_{Flc}^2 \cdot 60$$

The **Motor ovrlld preal.** is available on digital output (code 65), it is 1 with **Motor I2t accum = 90 %** and 0 when **Motor I2t accum = 0**.

The **Overld available** signal is available on digital output (code 6), it is 0 with **Motor I2t accum = 100 %** and 1 with **Motor I2t accum = 0**.

The **Drive ovrlld preal.** is available on digital output (code 66), it is 1 with **Drive I2t accum = 90 %** and 0 when **Drive I2t accum = 0**.

The **Overld available** signal is available on digital output (code 67), it is 0 with **Drive I2t accum = 100 %** and 1 with **Drive I2t accum = 0**.

| American sizes (2B/4B) | European sizes (2B/4B) | Derating _fct | American sizes (2B) | European sizes (2B) | Derating _fct | American sizes (4B) | European sizes (4B) | Derating _fct |
|------------------------|------------------------|---------------|---------------------|---------------------|---------------|---------------------|---------------------|---------------|
| TPD32-...-17..         | TPD32-...-20..         | 0.85          | TPD32-...-850-2B    | TPD32-...-1000-2B   | 0.80          |                     | TPD32-...-1500-4B   | 0.86          |
| TPD32-...-35..         | TPD32-...-40..         | 0.875         |                     | TPD32-...-1200-2B   | 0.83          |                     | TPD32-...-1700-4B   | 0.79          |
| TPD32-...-56..         | TPD32-...-70..         | 0.8           |                     | TPD32-...-1500-2B   | 0.86          |                     | TPD32-...-2000-4B   | 0.75          |
| TPD32-...-88..         | TPD32-...-110..        | 0.8           |                     | TPD32-...-1800-2B   | 0.77          |                     | TPD32-...-2400-4B   | 0.75          |
| TPD32-...-112..        | TPD32-...-140..        | 0.8           |                     | TPD32-...-2000-2B   | 0.75          |                     | TPD32-...-2700-4B   | 0.74          |
| TPD32-...-148..        | TPD32-...-185..        | 0.8           |                     | TPD32-...-2400-2B   | 0.75          |                     |                     |               |
| TPD32-...-224..        | TPD32-...-280..        | 0.8           |                     | TPD32-...-2700-2B   | 0.74          |                     |                     |               |
| TPD32-...-280..        | TPD32-...-350..        | 0.8           |                     | TPD32-...-2900-2B   | 0.76          |                     |                     |               |
| TPD32-...-336..        | TPD32-...-420..        | 0.8           |                     | TPD32-...-3300-2B   | 0.71          |                     |                     |               |
| TPD32-...-400..        | TPD32-...-500..        | 0.8           |                     |                     |               |                     |                     |               |
| TPD32-...-450..        | TPD32-...-650..        | 0.69          |                     |                     |               |                     |                     |               |
| TPD32-...-560..        | TPD32-...-770..        | 0.72          |                     |                     |               |                     |                     |               |

Table 6.14.6.1: I2t derating

- Overload current** Armature current that is permissible during the overload time (set with **Overload time**). It is always 200% as a maximum of the active current at **Full load curr** and therefore proportional to the torque.
- Base current** Armature current that is permissible during the pause time (set with **Pause time**). The percentage refers to the active current at **Full load curr**.
- Overload time** Maximum time in which the **Overload current** is permissible.
- Pause time** Minimum time between two Overload cycles. During this time the **Base current** is permissible.
- Motor I2t accum** It gives a percentage definition of the integration of the rms current. 100% = trip level motor I2t . **Motor I2t accum** is equal to 100% if  $(\text{Overload current}^2 \times \text{Overload time})$  is reached but in any case with a maximum limit of  $[(150\% \text{ FLC})^2 \times 60 \text{ sec}]$ .
- Motor ovrlld preal.** This signal can be set on a digital output (code 65). It goes to the high level (1) when **Motor I2t accum** = 90 %. It goes to low level (0) when **Motor I2t accum** = 0.
- Drive I2t accum** It gives a percentage definition of the integration of the rms current. 100% = trip level drive I2t. **Drive I2t accum** is equal to 100% if  $[(150\% \text{ Derated Drive Current}^{(*)})^2 \times 60 \text{ sec}]$  is reached.
- Drive ovrlld preal.** This signal can be set on a digital output (code 66). It goes to the high level (1) when **Drive I2t accum** = 90 %. It goes to low level (0) when **Drive I2t accum** = 0.
- Overld available** Indicates whether an overload is possible this very instant or whether this is not yet the case, due to the set cycle (**Pause time** not yet expired).  
High Overload possible  
Low Overload currently not possible
- Overload state** If the **Overload mode** parameter is defined so that the current is not limited by the Overload control, the **Overload state** can be used to determine whether the current is within the set limits or not.  
High Current exceeds the set limits  
Low Current does not exceed the set limits.

**Note!** Overload state is not a latched output. For I2t, it is can be considered as a one shot.



The Overload control is enabled with the **Enable overload** parameter. It can be used to protect the drive or motor from thermal overloads with cyclical loads.

The max. possible values (as for the converter) are obtainable through the following curves. The operating point must always be below the corresponding curve. At the verification it is to state, that the torque and the current are proportional.

The **Overld available** parameter allows to understand if the drive is ready to supply an overload current. If the current exceeds the value defined by the **Base current** parameter, the time set by the **Overload time** parameter starts to run. Once this time has expired, the current is limited again to the Base current. This takes place irrespective of how high the overload was and how long it lasted. A subsequent overload is permissible immediately after the time set by the **Pause time** parameter. If **Overload mode** is set to “Curr not limited”, The current is not limited but the **Overload state** parameter indicates whether it is out of the defined range.

**Caution!**

A wrong input of the values may cause the destruction of the device!

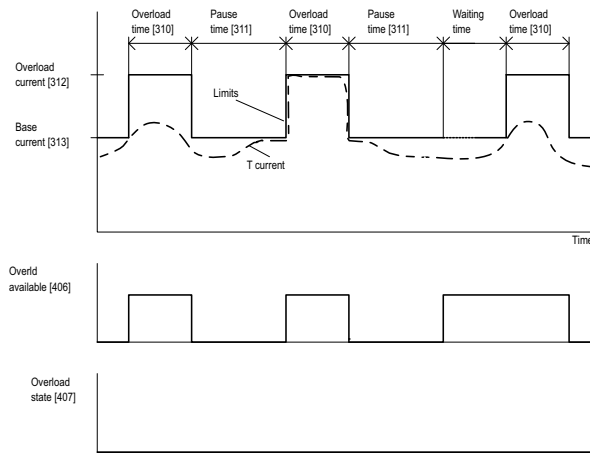

Figure 6.14.6.1: Overload control (Overload mode = curr limited)

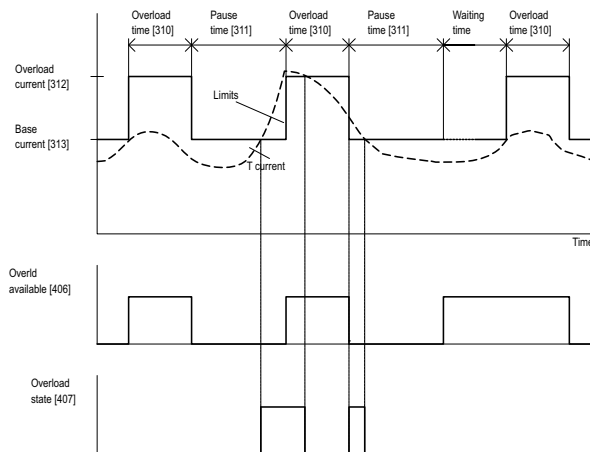
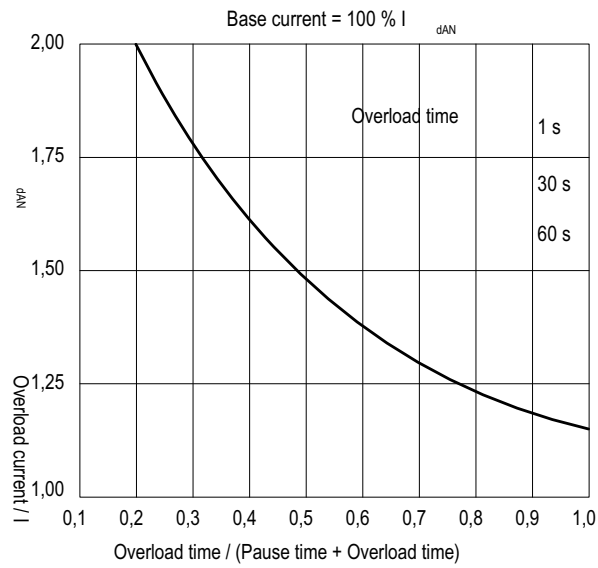

Figure 6.14.6.2: Overload control (Overload mode = curr not limited)

**(American size)**

$$I_{dAN} = 17 \text{ A}$$



$$I_{dAN} = 35 \text{ A}$$

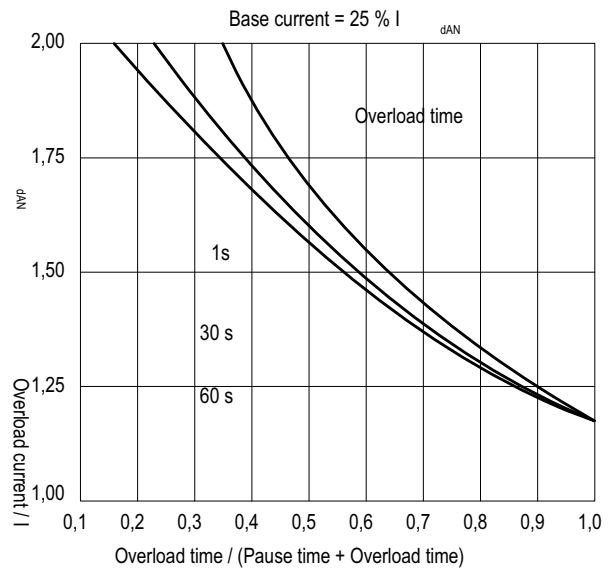
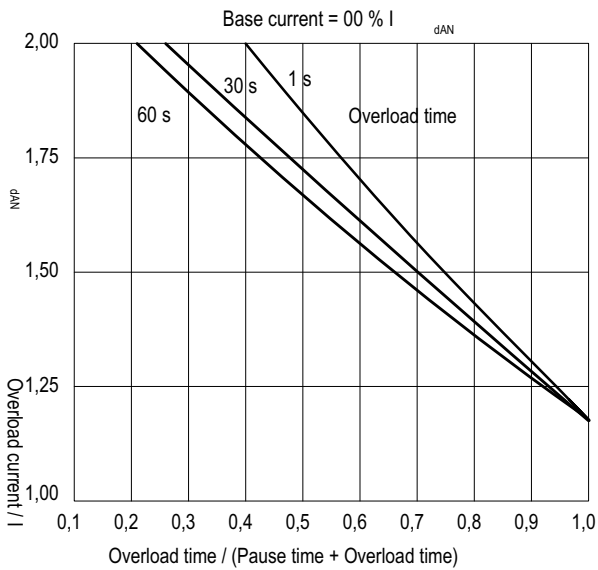

(American size)

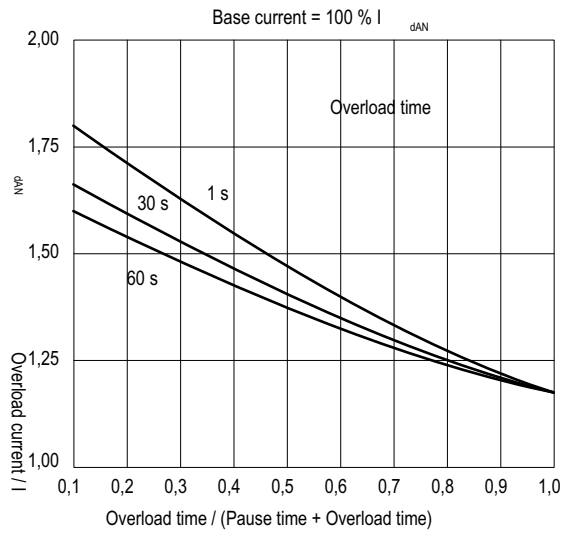
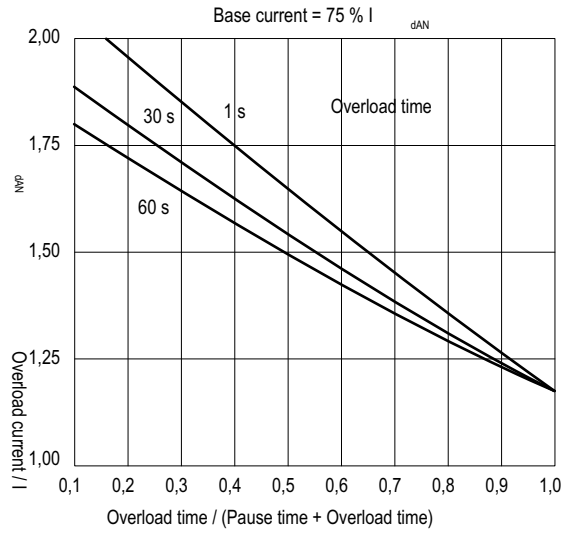
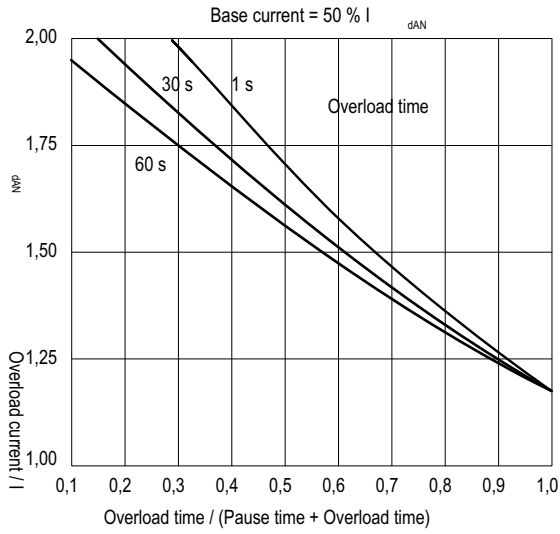

$I_{dAN} = 56 \text{ A}$

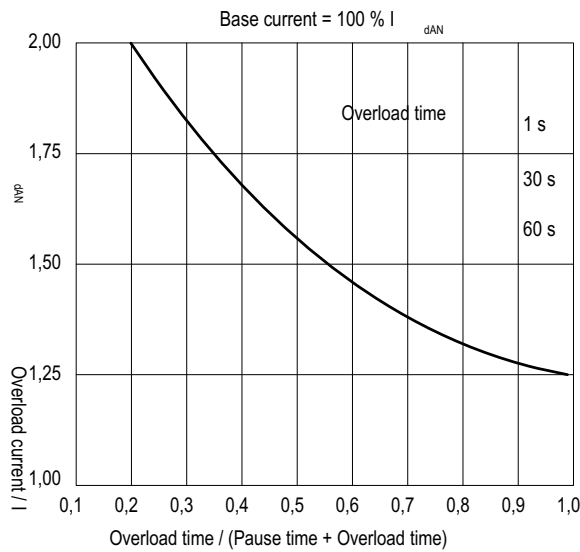

(American size)

$$I_{dAN} = 88 \text{ A}$$

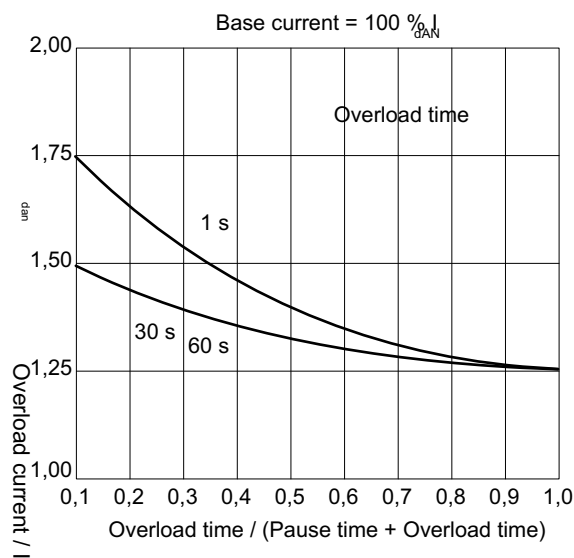
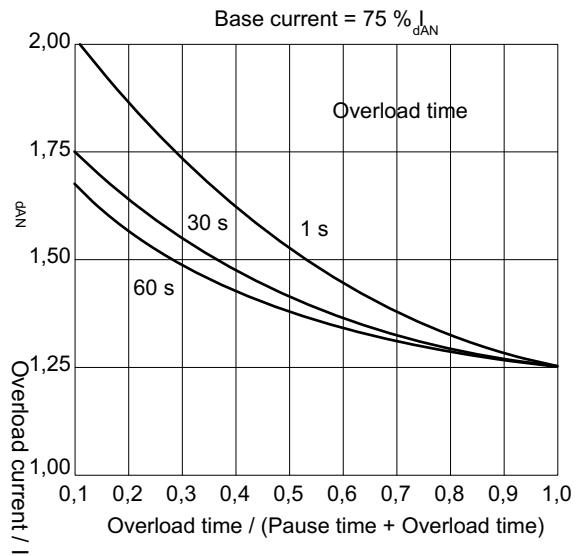
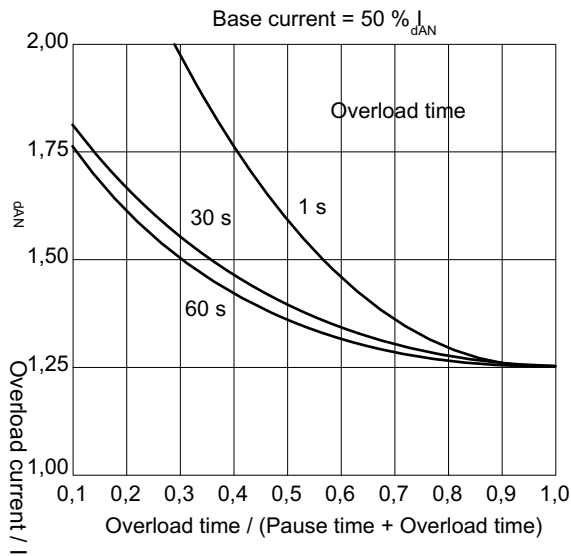
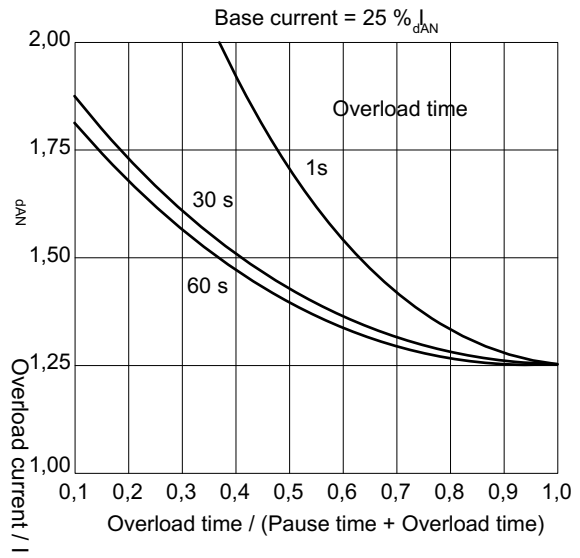
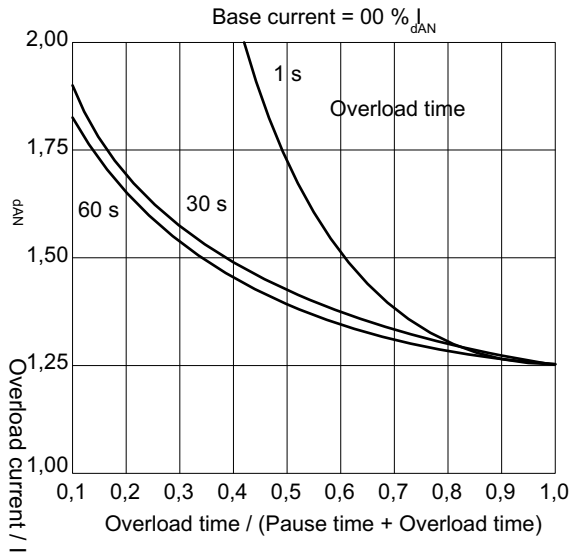

(American size)

$$I_{dAN} = 112 \text{ A}$$

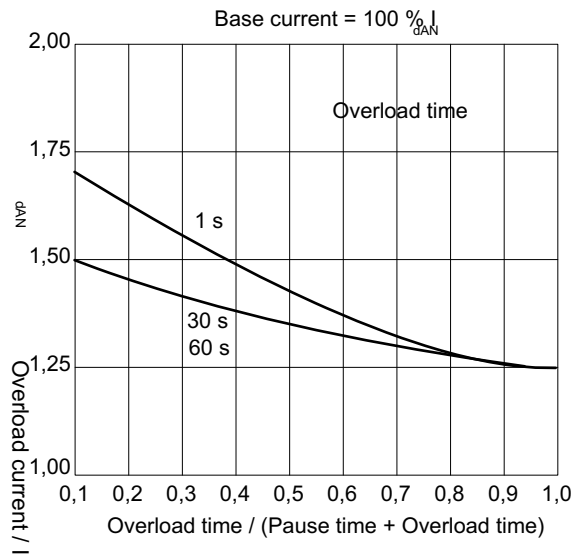
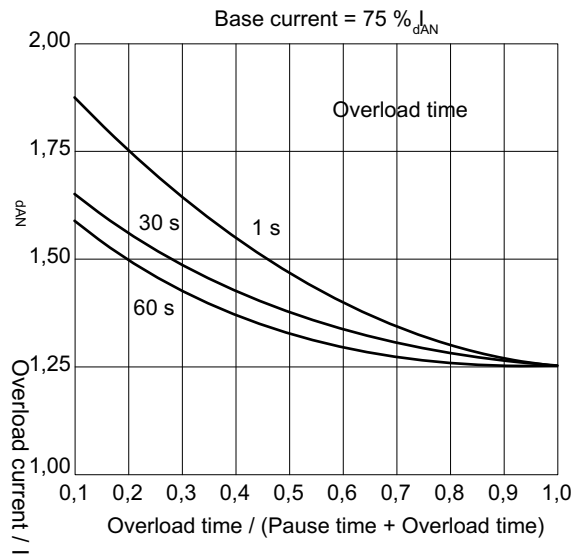
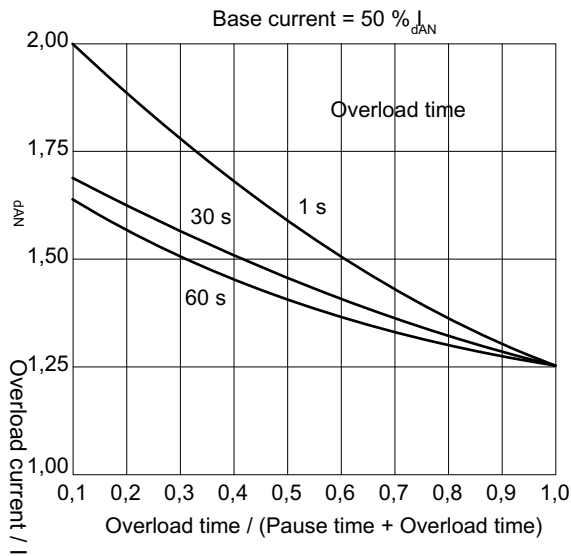
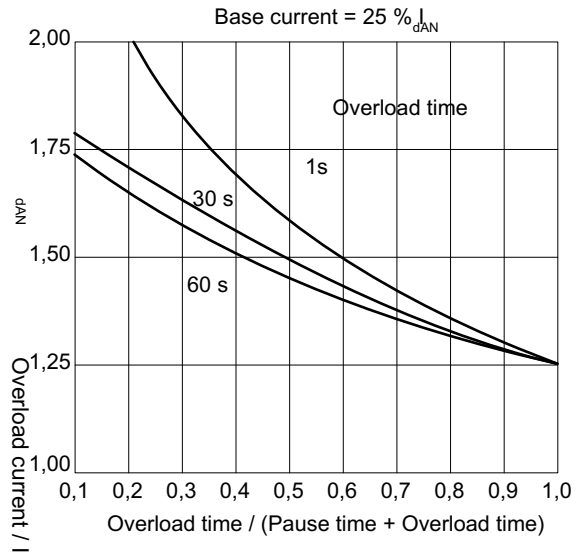
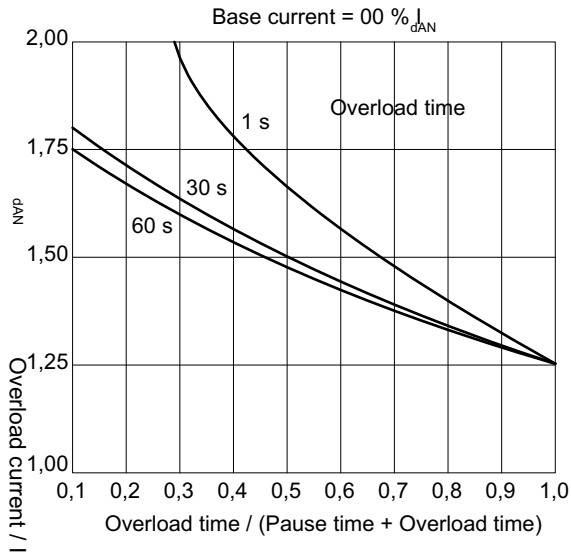

(American size)

$$I_{dAN} = 148 \text{ A}$$

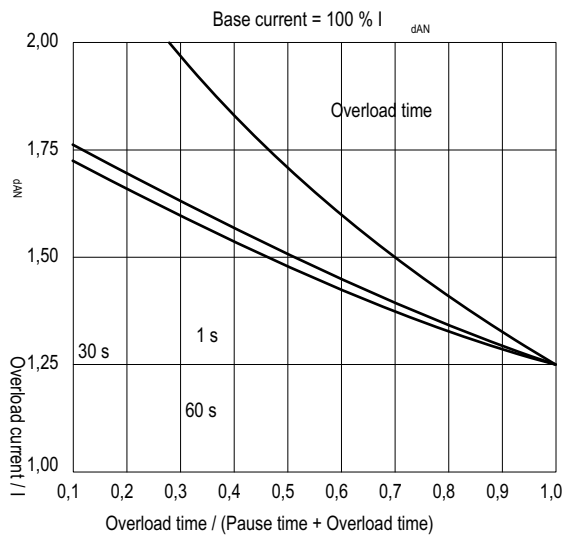
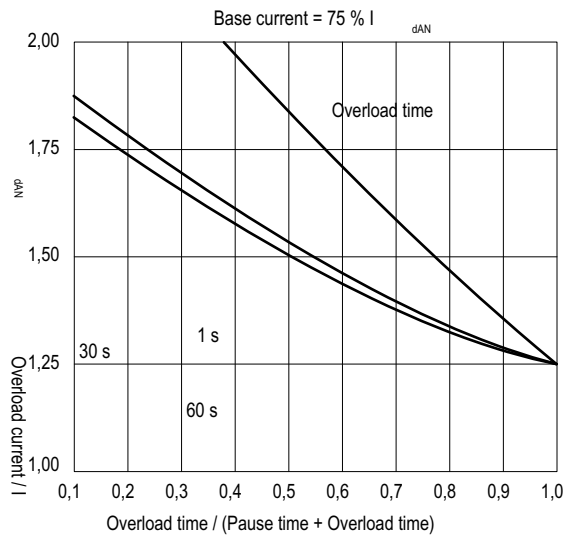
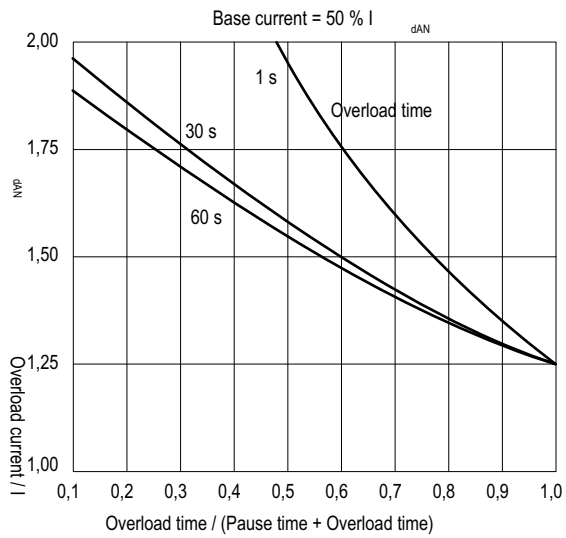
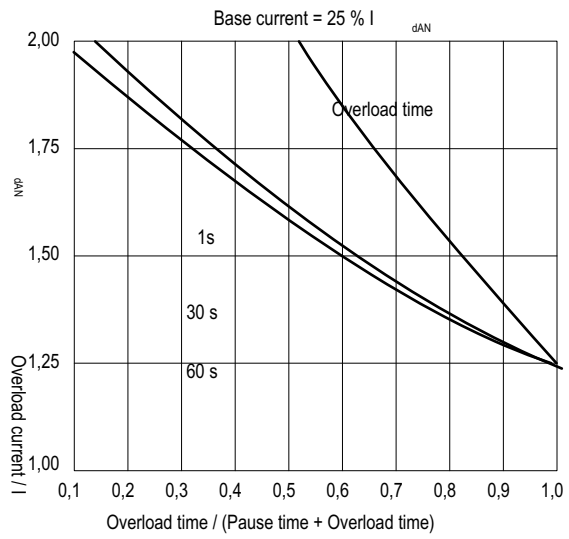
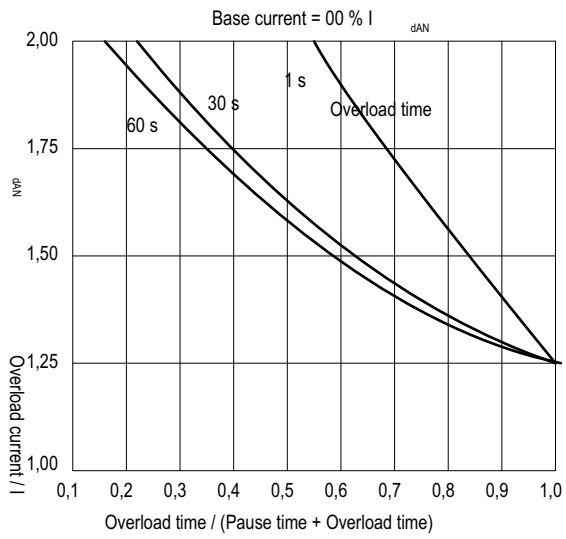

(American size)

$I_{dAN} = 224 \text{ A}$

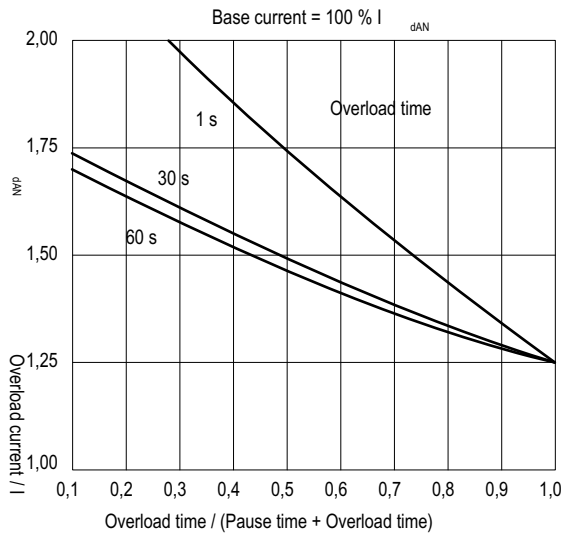
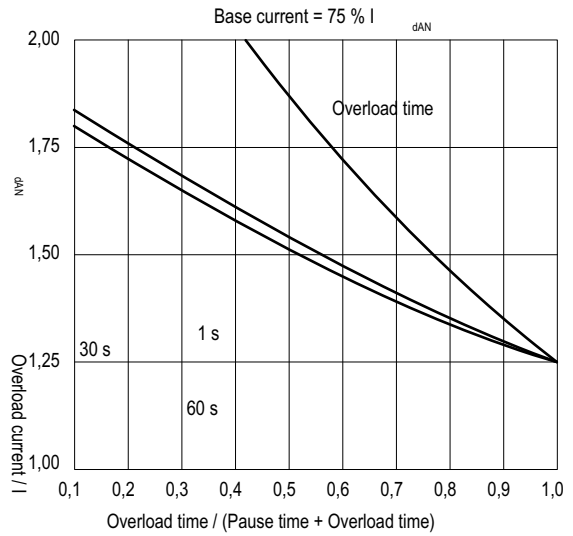
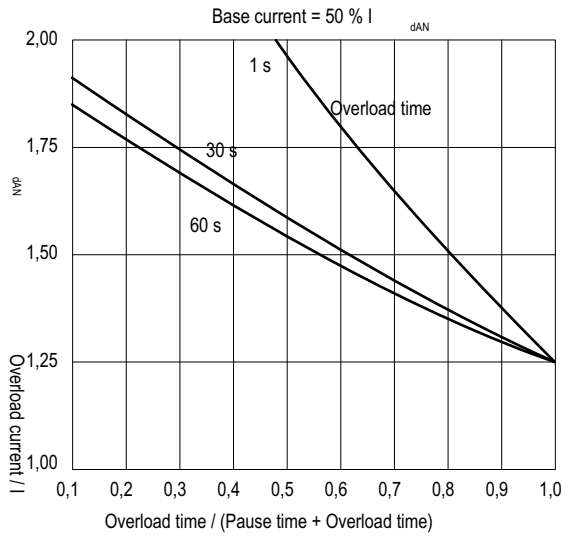
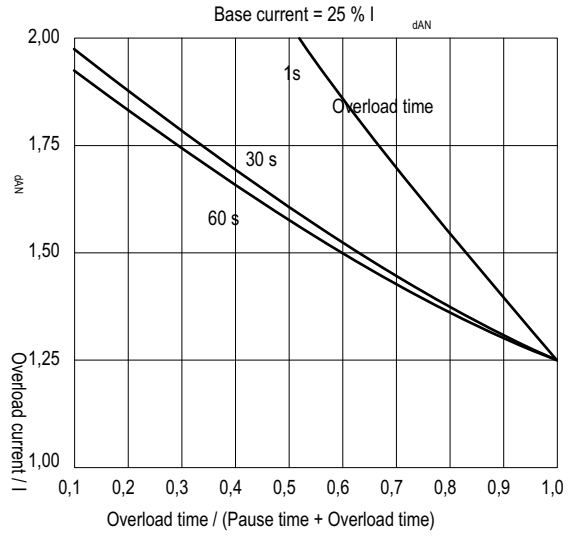
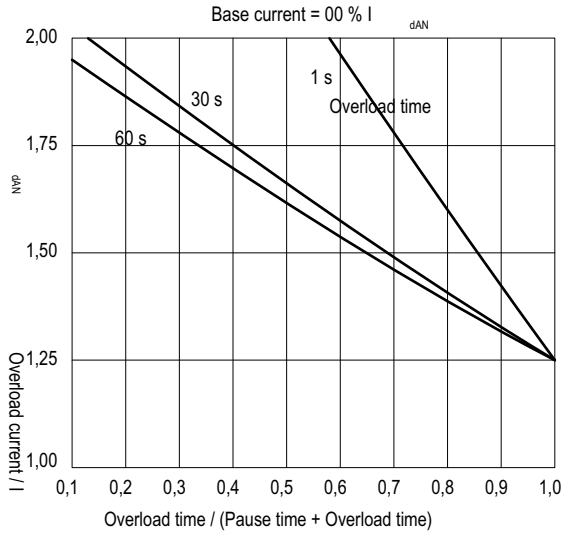

(American size)

$$I_{dAN} = 280 \text{ A}$$

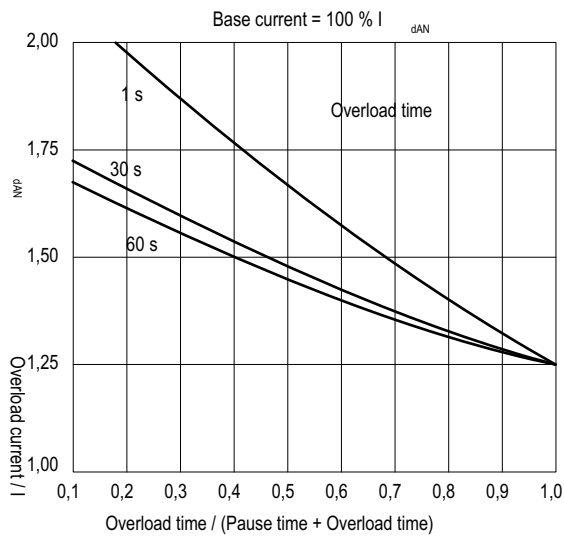
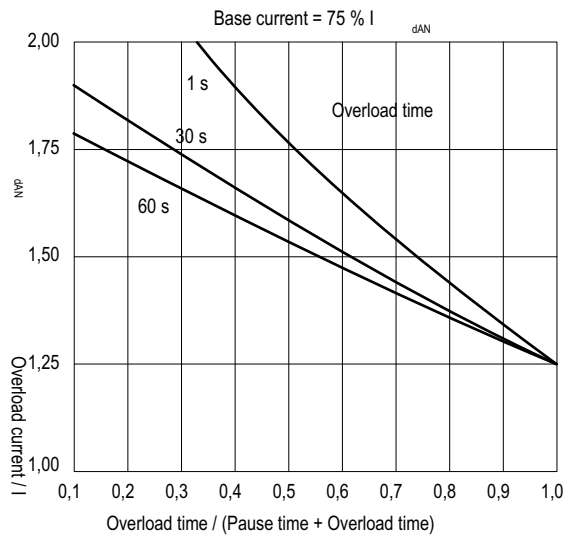
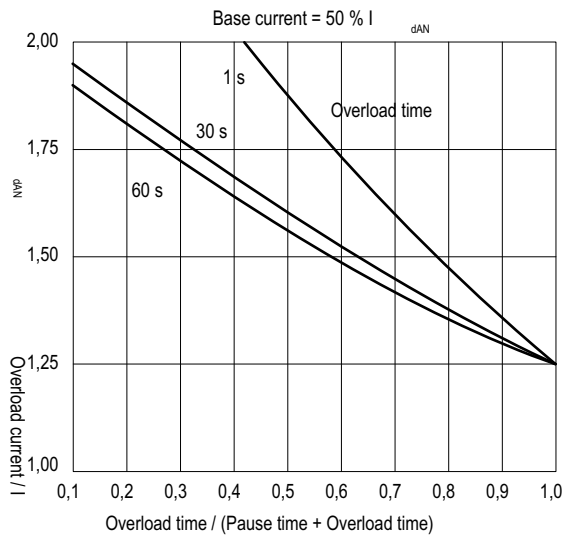
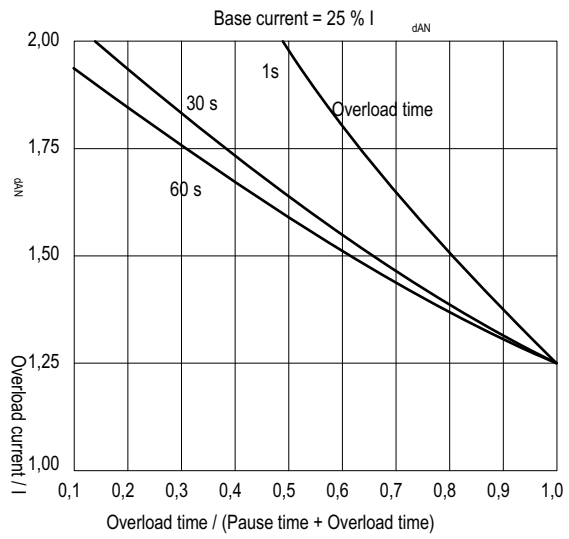
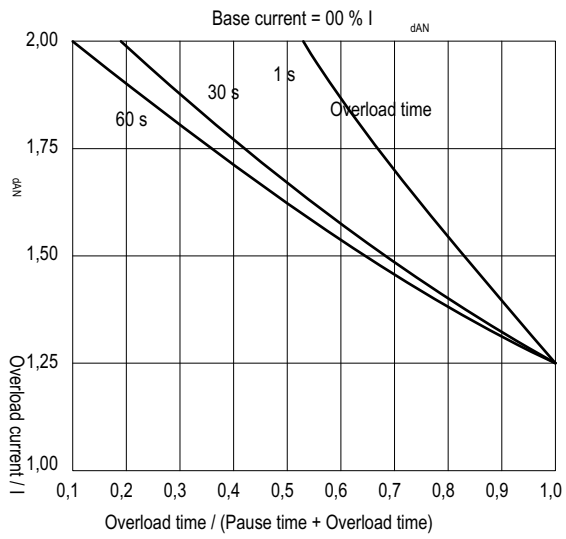



(American size)

$$I_{dAN} = 336 \text{ A}$$

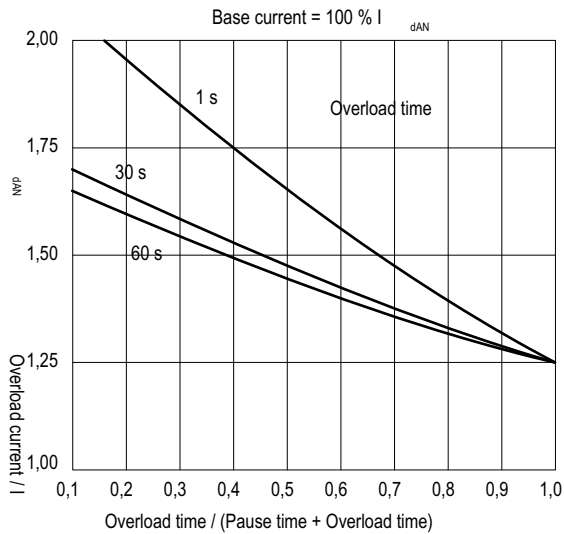
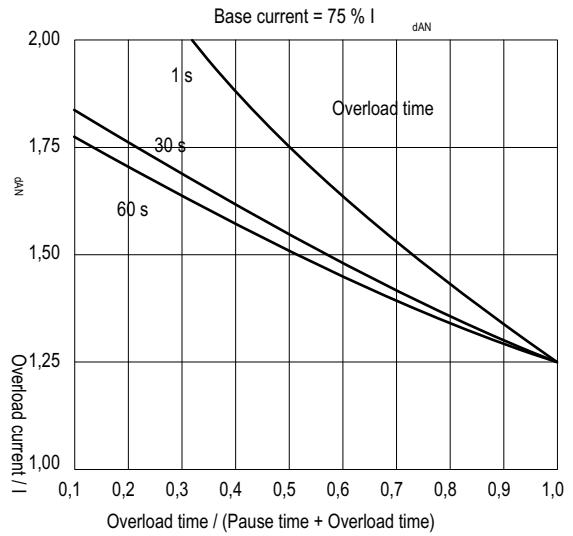
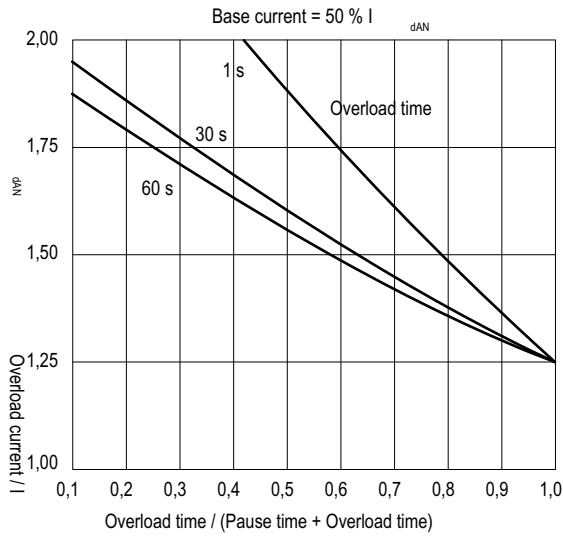
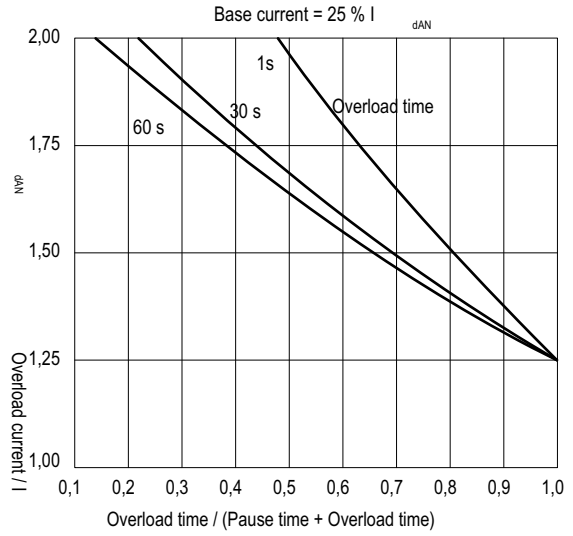
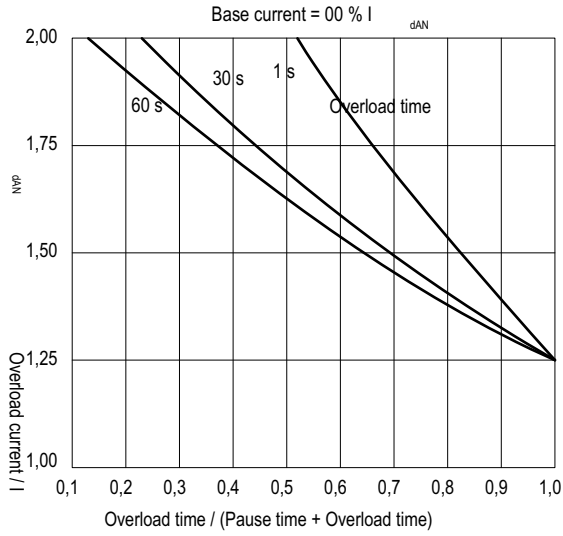

(American size)

$$I_{dAN} = 400 \text{ A}$$

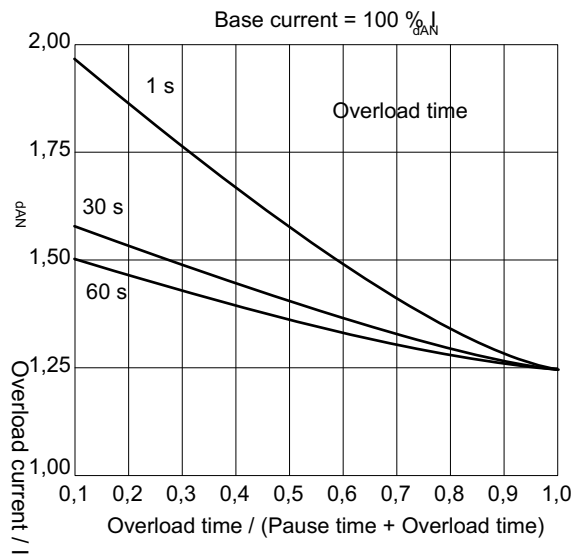
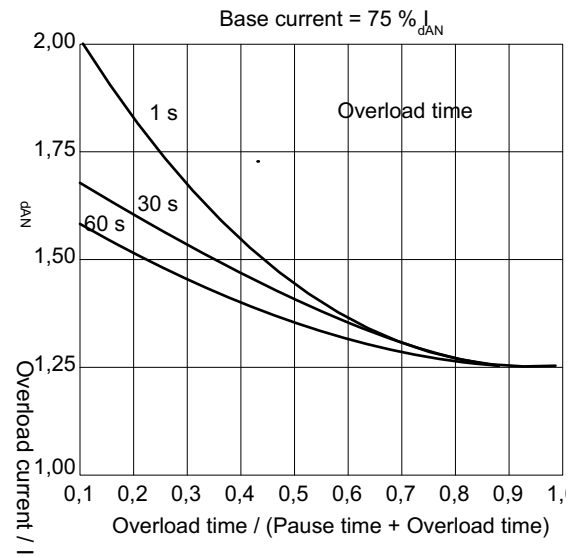
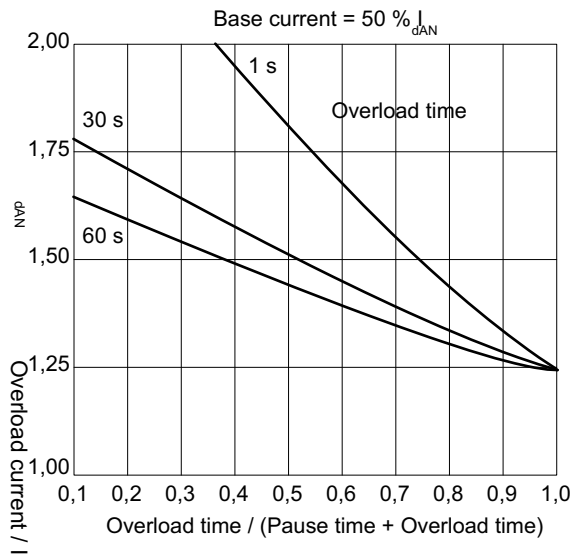
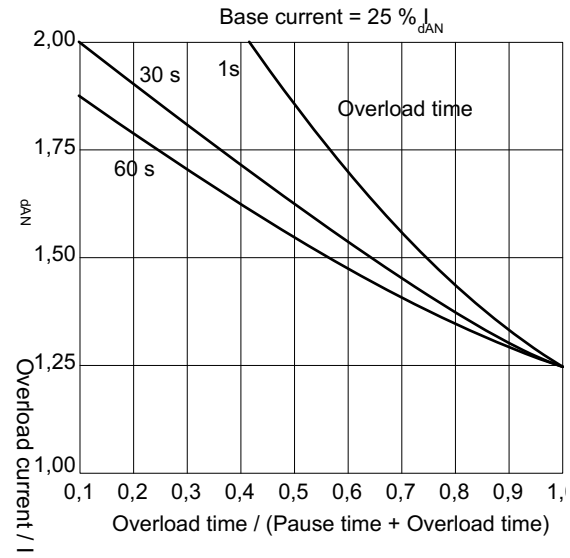
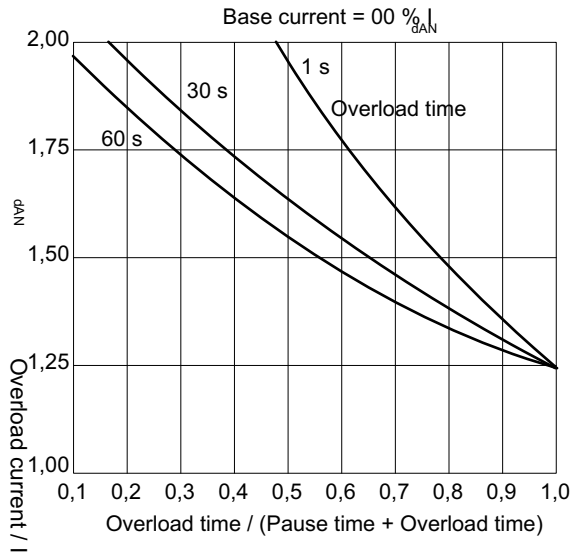

(American size)

$I_{dAN} = 450 \text{ A}$

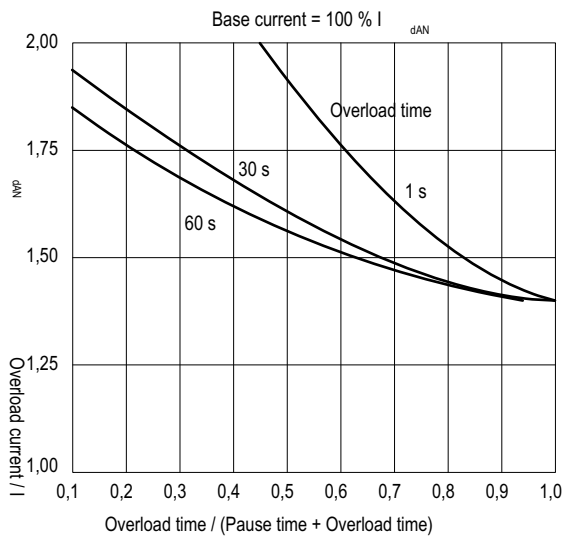
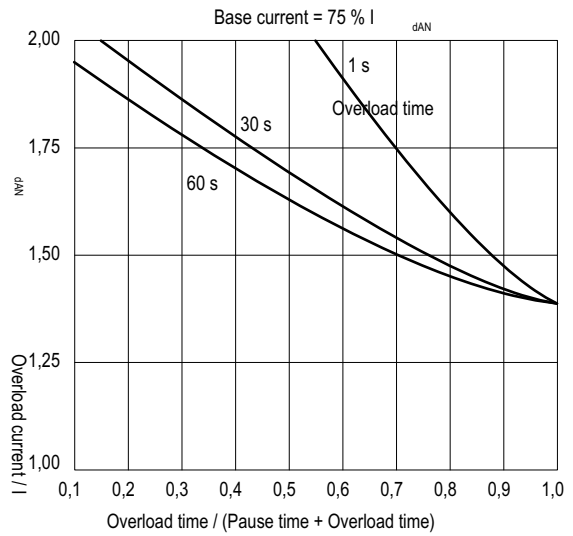
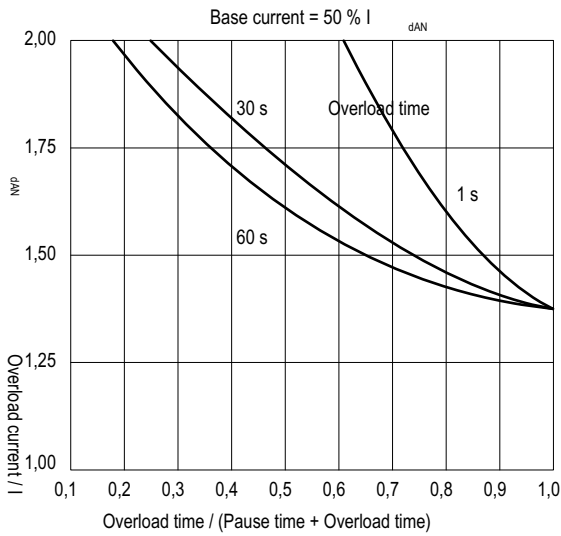
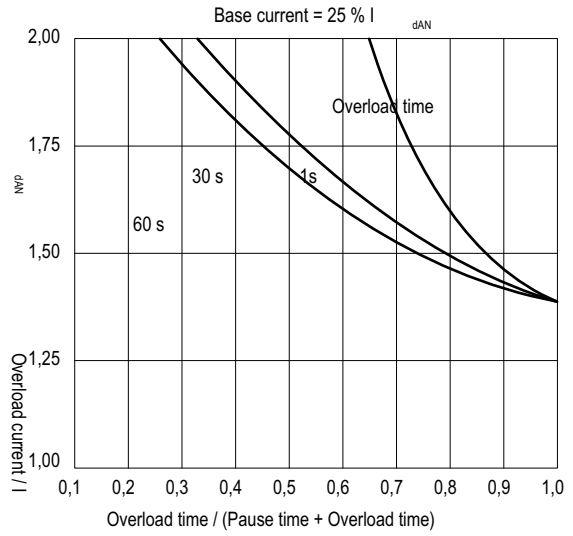
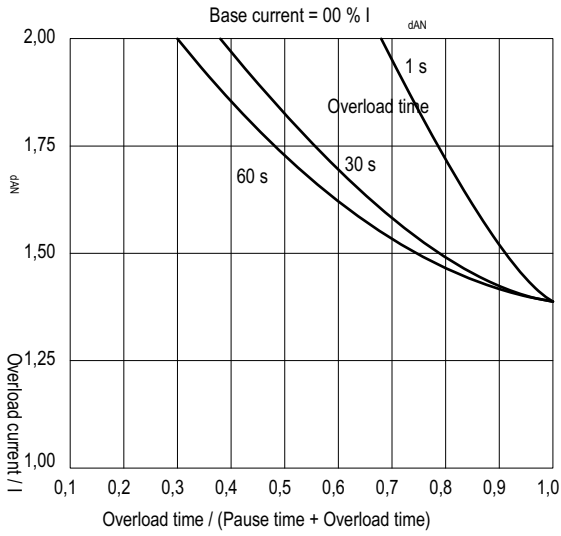

(American size)

$$I_{dAN} = 560 \text{ A}$$

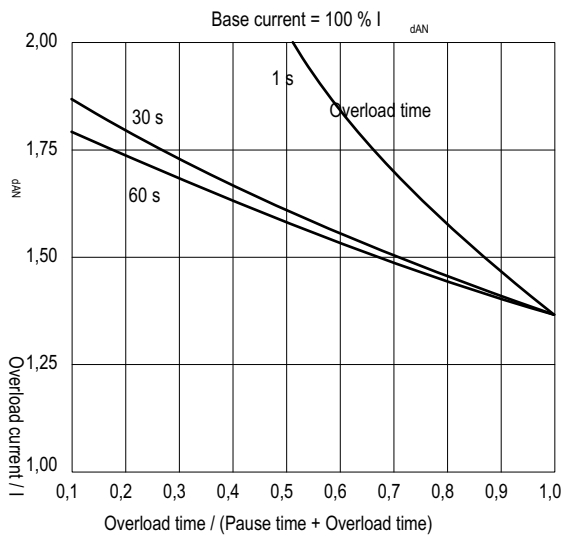
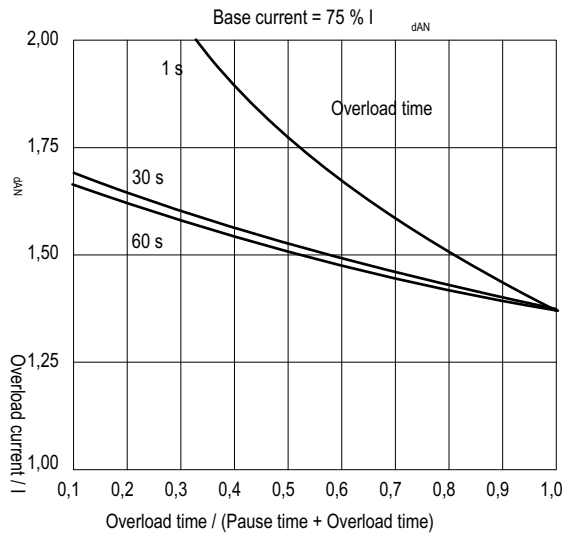
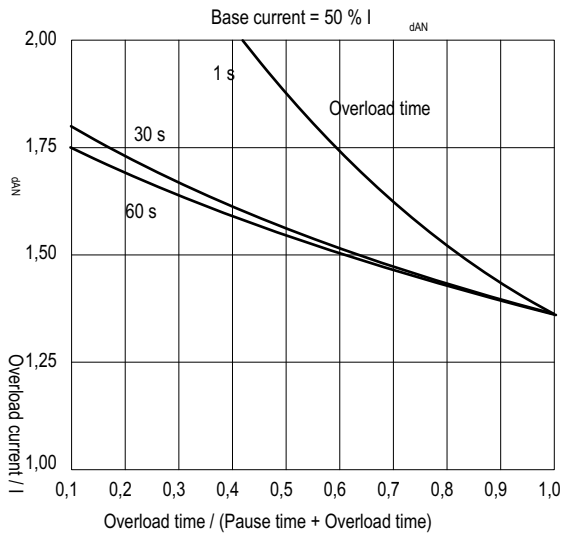
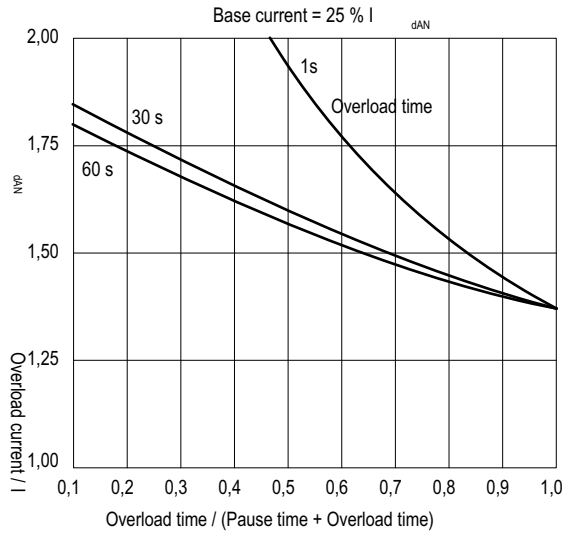
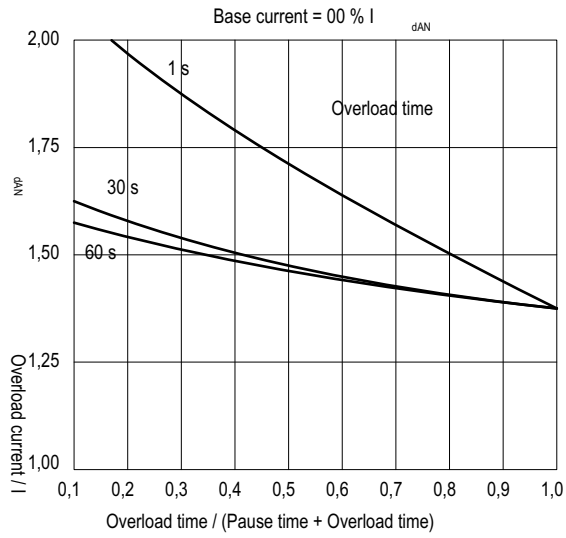

(American size)

$I_{dAN} = 850 \text{ A}$

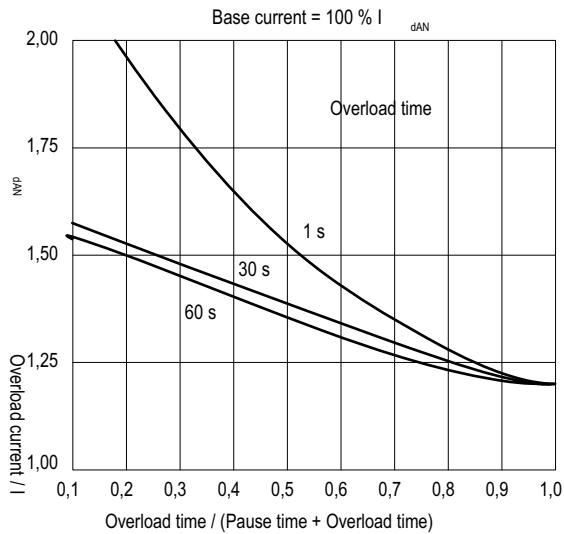
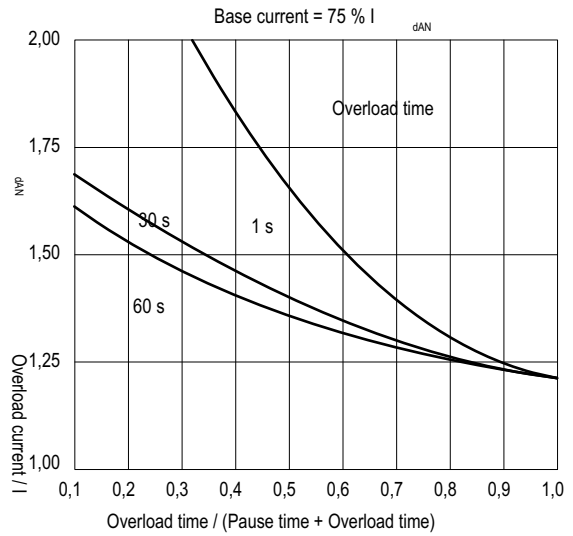
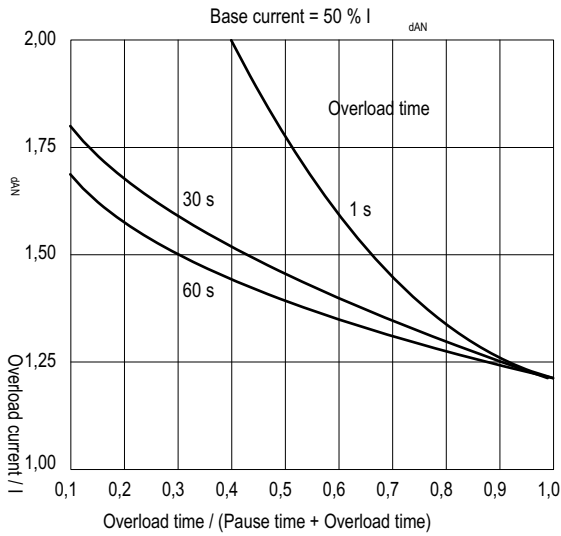
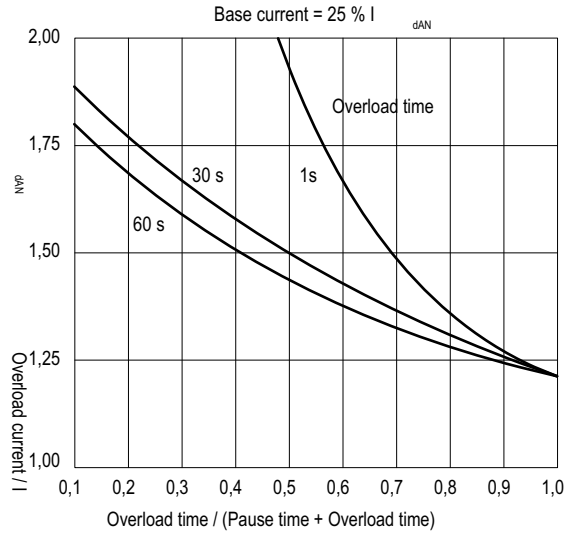
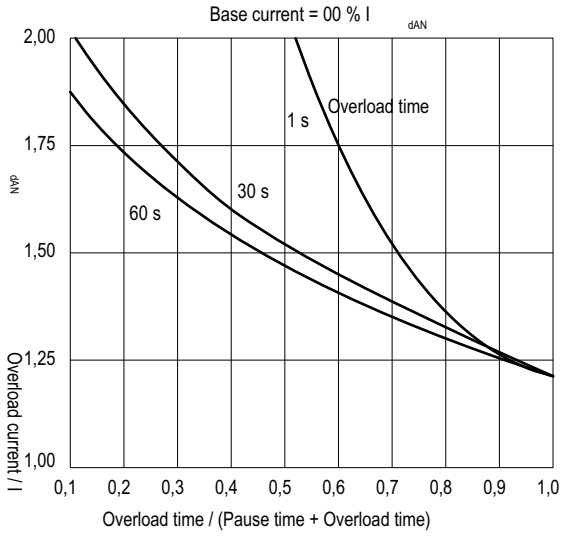

(European size)

$$I_{dAN} = 20 \dots 70 \text{ A}$$

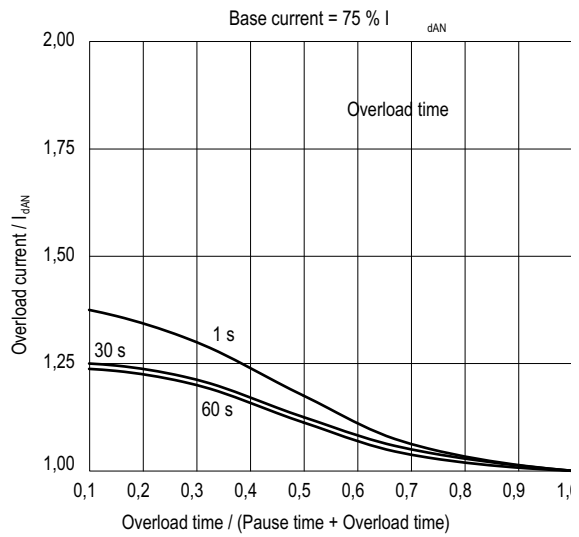
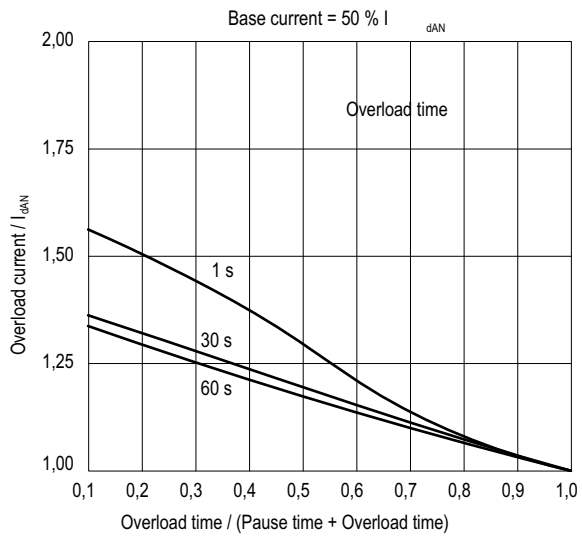
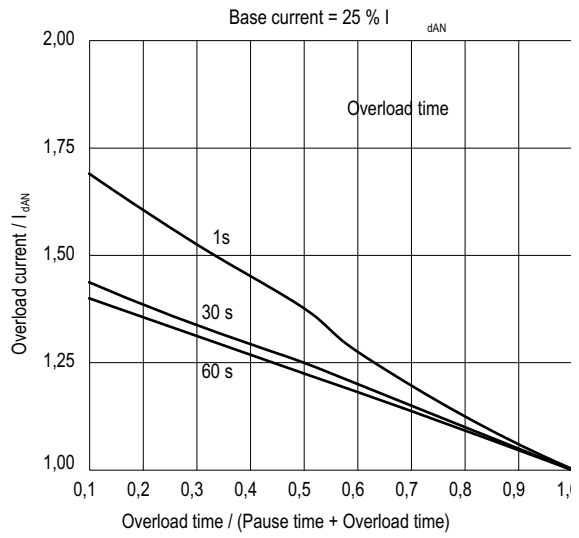
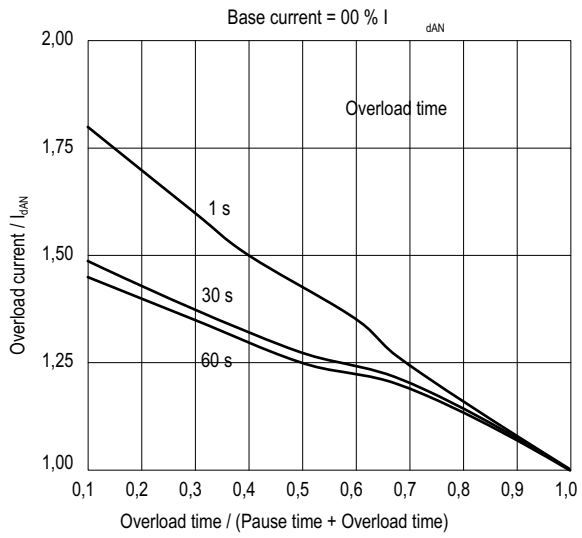

(European size)

$I_{dAN} = 110 \dots 185 \text{ A}$

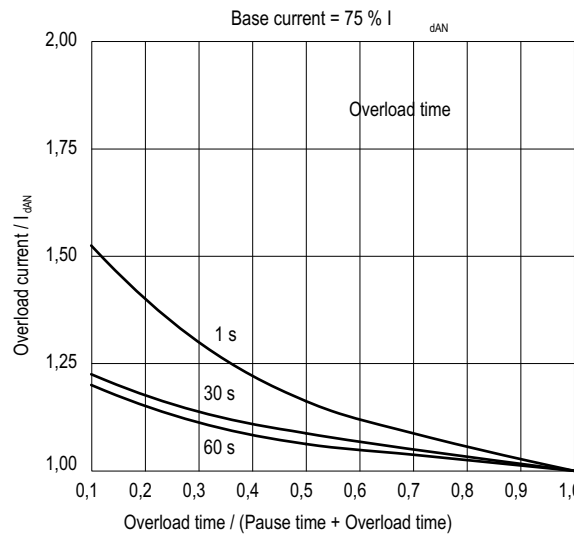
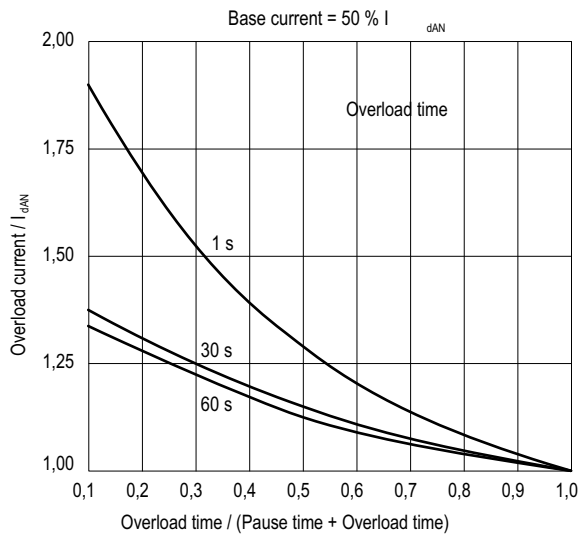
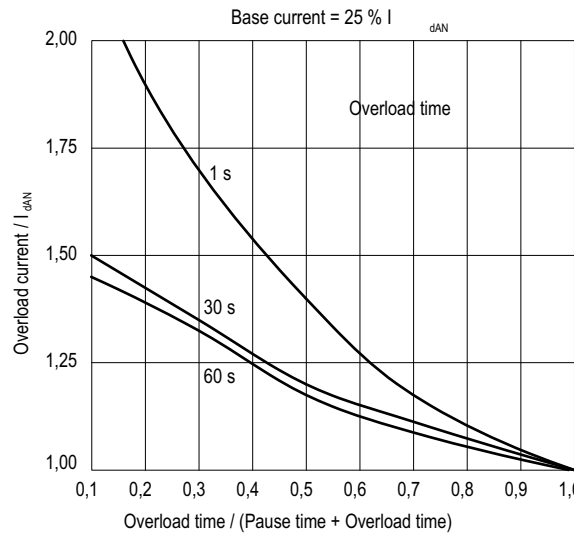
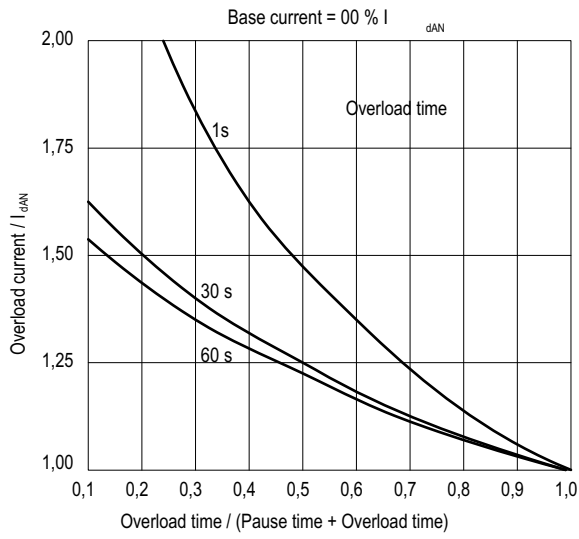

(European size)

$I_{dAN} = 280 \dots 650 \text{ A}$

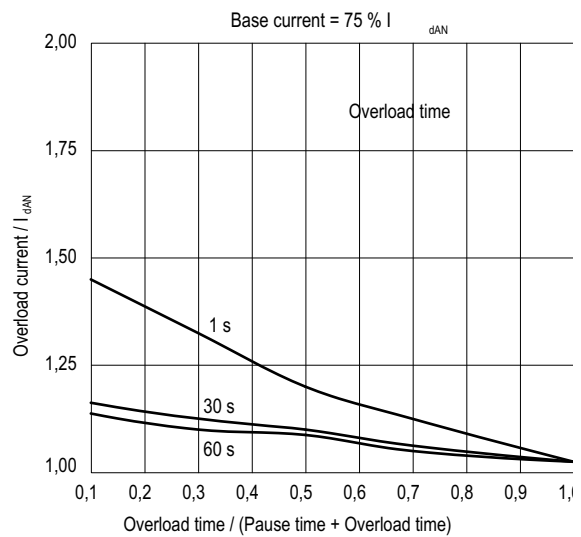
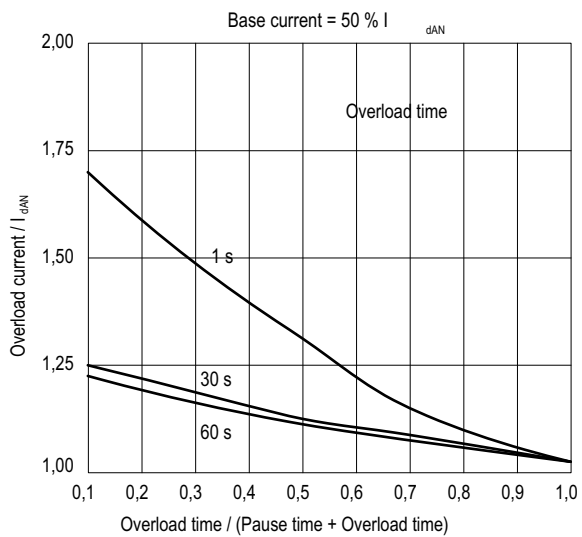
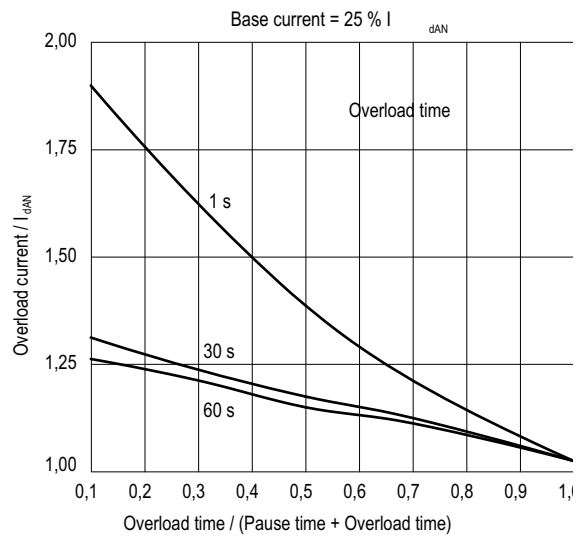
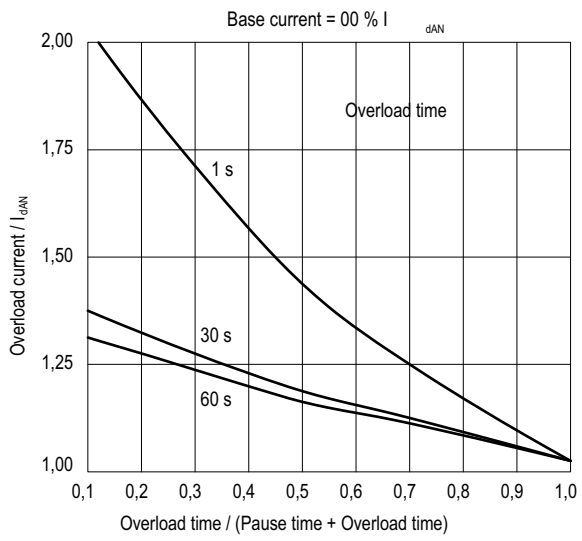



(European size)

$I_{dAN} = 770 \dots 1050 \text{ A}$

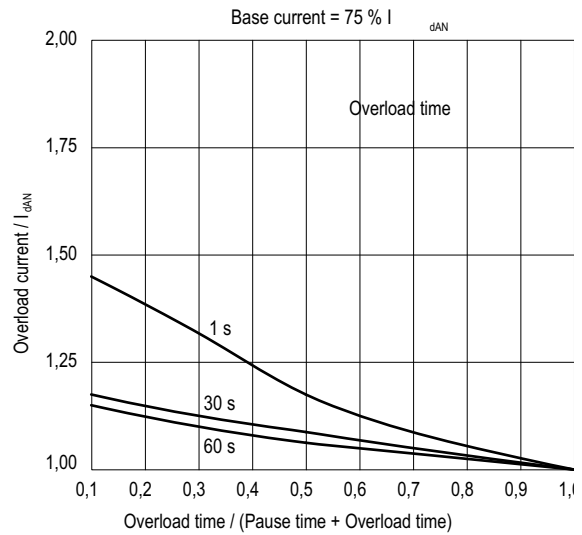
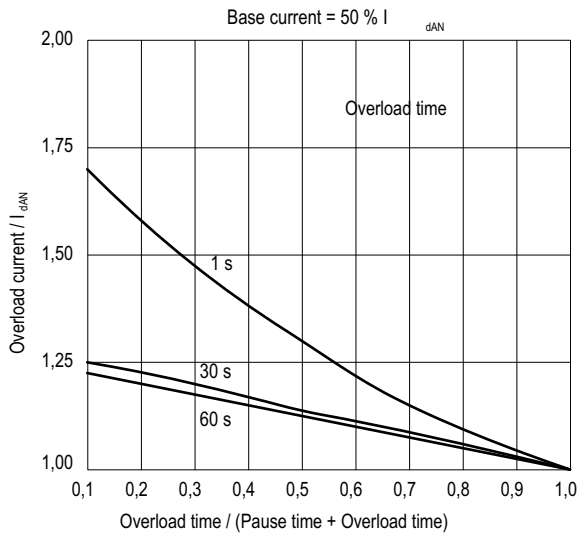
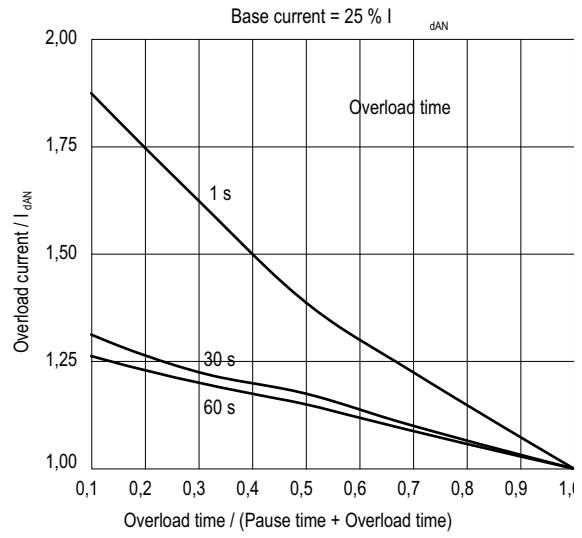
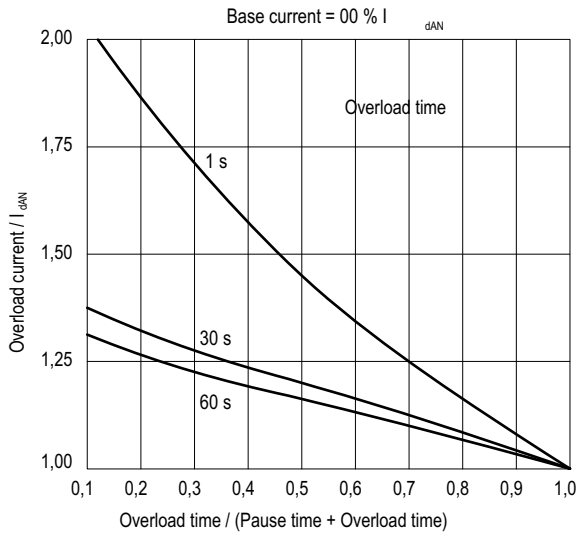

### Example

Motor P = 30 kW, Armature volts = 420 V, Armature current = 82 A

Loadcycle The motor is overloaded for 1 s at 180 % of the rated current, then it works at the rated load for at least 5 s. Four quadrant converter.

Procedure At first select the dc current according to the motor rated current. Usually it is the motor rated current. If the determined motor operating point is not below the Overload curve of the converter, the calculation should be repeated with the next larger converter size.

Converter TPD32-400/420-110-4B

Diagram

$$\frac{\text{Base current}}{I_{dAN}} = \frac{82 \text{ A}}{110 \text{ A}} = 0.75$$

This means that the diagram for the converters 110 A ... 185 A with a Base current = 75 % has to be considered for the calculation.

Operating point Basis: rated data of the converter

$$\text{Overload current} = 82 \text{ A} \cdot 1.8 = 147.6 \text{ A}$$

$$\text{Overload factor} = \frac{\text{Overload current}}{I_{dAN} \text{ (of converter)}} = \frac{147.6 \text{ A}}{110 \text{ A}} = 1.34$$

$$\frac{\text{Overload time}}{\text{Pause time} + \text{Overload time}} = \frac{1 \text{ s}}{5 \text{ s} + 1 \text{ s}} = 0.16$$

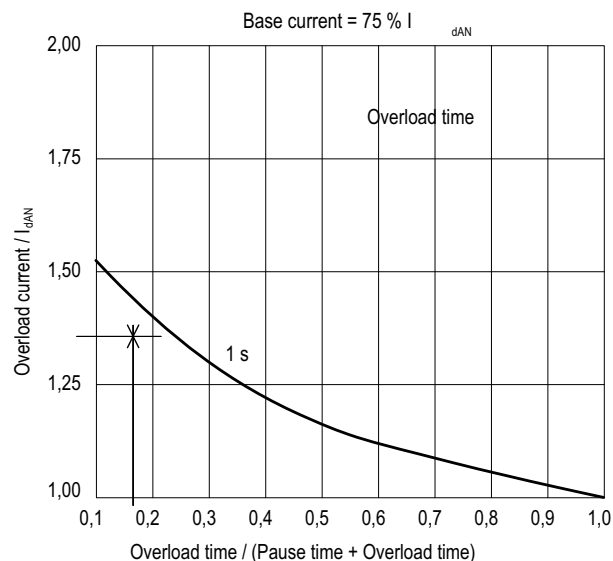

Figure 6.14.6.3: Example- Operating point of drive

The calculated operating point is below the corresponding curve for an overload time of 1 s. Therefore the converter is suitable for the application. The following two settings are possible:

|                         |         |    |       |
|-------------------------|---------|----|-------|
| <b>Full load curr</b>   | 82 A    | or | 110 A |
| <b>Enable overload</b>  | Enabled |    |       |
| <b>Overload current</b> | 180 %   | or | 134 % |
| <b>Base current</b>     | 100 %   | or | 75 %  |
| <b>Overload time</b>    | 1 s     |    |       |
| <b>Pause time</b>       | 5 s     |    |       |

**Note!** The percentages for **Overload current** and **Base current** are referred to **Full load curr** and not to the converter rated current!

## 6.14.7 Stop control

| FUNCTIONS |                     |                       |
|-----------|---------------------|-----------------------|
|           | <b>Stop control</b> |                       |
|           | [626]               | Stop mode             |
|           | [627]               | Spd 0 trip delay [ms] |
|           | [628]               | Trip cont delay [ms]  |
|           | [630]               | Jog stop control      |

This function is intended to help the system engineer to coordinate the AC input contactor with the drive enabling. According to the selected mode the terminals 75 and 76 drive the ON/OFF of the AC input contactor.

Basically, when the drive receives the Start command the Relay 2 closes the AC input contactor, the drive waits for a certain time the AC input voltage, synchronizes itself and starts the motor. When the drive stops, the motor goes to zero speed. When the zero speed is reached, the drive is disabled only when a “Spd 0 trip” delay is elapsed. Then after the “Trip cont delay” the Relay 2 opens to remove the supply from the drive.

| Parameter description  | No. | Value |       |                  |                  | Standard Configuration |
|--|-----|-------|-------|------------------|------------------|------------------------|
|  |     | min   | max   | Factory American | Factory European |                        |
| <b>Stop mode</b><br>OFF (0)<br>Stop & speed 0 (1)<br>Fast stp & spd 0 (2)<br>Fst / stp & spd 0 (3) | 626 | 0     | 3     | Stop & Speed 0   | Stop & Speed 0   | *<br>Relay 75 / 76     |
| <b>Spd 0 trip delay [ms]</b>   | 627 | 0     | 40000 | 0                | 0                | -                      |
| <b>Trip cont delay [ms]</b>  | 628 | 0     | 40000 | 0                | 0                | -                      |
| <b>Jog stop control</b><br>OFF (0)<br>ON (1)   | 630 | 0     | 1     | OFF              | OFF              | -                      |

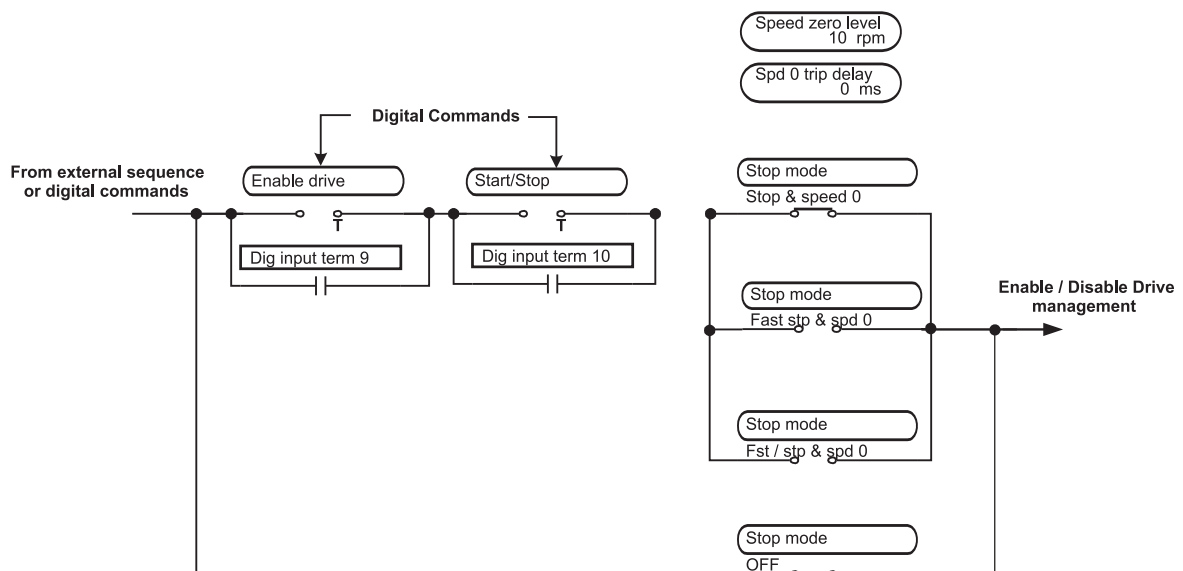

Figure 6.14.7.1: Start and stop management

|                         |  |  |
|-------------------------|--|--|
| <b>Stop mode</b>        | OFF  | The function is disabled.  |
|                         | Stop & Speed 0   | The Start command determines the behavior. If the Start command is not present (digital or via terminal strip) and the drive is stopped, the converter is blocked and the contact is open. When the Start command is given, the converter is enabled and the contact is closed. Disabling the Start command and after reaching zero speed, the converter is blocked after a timespan set by <b>Spd 0 trip delay</b> . The relay contact between the terminals 75/76 opens after a timespan set by <b>Trip cont delay</b> .   |
|                         | Fast stp & spd 0   | The Fast Stop command determines the behavior. If the Fast Stop command is present (digital or via terminal strip; f.e. with 0 V on the terminal 14) and the drive is stopped, the converter is blocked and the contact is open. When the Fast Stop command is disabled (i.e. with 24 V on the terminal 14), The converter is enabled and the contact is closed. Entering the Fast Stop command, when the zero speed has been reached, the converter is blocked after a timespan set with <b>Spd 0 trip delay</b> .  |
|                         | Fst / stp & spd 0  | The Fast Stop and Start commands determine the behavior. When the Stop or Fast Stop commands are present and the drive is stopped, the converter is blocked and the contact is open. When the Start command is given or when the Fast Stop command is disabled, the converter is blocked and the contact is closed. When the Start command is disabled or when a Fast Stop command is entered and after reaching zero speed, the converter is stopped after a timespan set by <b>Spd 0 trip delay</b> . The relay contact between the terminals 75/76 opens after a timespan set by <b>Trip cont delay</b> . |
| <b>Spd 0 trip delay</b> | Delay time in ms between reaching zero speed and disabling of the converter.                   |  |
| <b>Trip cont delay</b>  | Delay time in ms between disabling and opening of the contact between the terminals 75 and 76. |  |
| <b>Jog stop control</b> | OFF  | The behavior selected by <b>Stop mode</b> has no influence on the Jog function.  |
|                         | ON   | The behavior selected by <b>Stop mode</b> is active also on the Jog function.  |

The mentioned “contact” can be either the one between the terminals 75/76 or a digital output (option TBO). In both cases during the display of the message the “**Stop control**” parameter must be selected. The function is factory set on the relay contact. The open contact, mentioned in the description, corresponds to 0 V on the digital output, while the closed contact corresponds to +24 V on the digital output.

**Note!** At all the described possibilities for **Stop mode**, the stop signal on the terminal 13 must be present. With **Main commands** = Digital, it is necessary to select **Enable drive** parameter = Enabled via keypad or Bus.

## 6.14.8 Brake control

| FUNCTIONS |                      |                     |
|-----------|----------------------|---------------------|
|           | <b>Brake control</b> |                     |
|           | [1295]               | Enable Torque pr    |
|           | [1262]               | Closing speed [rpm] |
|           | [1293]               | Torque delay [ms]   |
|           | [1294]               | Torque proving [%]  |
|           | [1266]               | Actuator delay [ms] |

| Parameter description | No.  | Value |       |                  |                  | Standard Configuration |
|-----------------------|------|-------|-------|------------------|------------------|------------------------|
|                       |      | min   | max   | Factory American | Factory European |                        |
| Enable Torque pr      | 1295 | 0     | 1     | Disabled         | Disabled         | -                      |
| Closing speed [rpm]   | 1262 | 0     | 200   | 30               | 30               | -                      |
| Torque delay [ms]     | 1293 | 0     | 30000 | 3000             | 3000             | -                      |
| Torque proving [%]    | 1294 | 0     | 200   | 75               | 75               | -                      |
| Actuator delay [ms]   | 1266 | 0     | 30000 | 1000             | 1000             | -                      |

The purpose of this function is to ensure that the machine develops a torque which is capable of supporting the load of a crane or hoist during the transient brake release phase, in any direction.

- Enable Torque pr** Enables the brake control function, making it possible to apply the torque capable of supporting the load during the transient brake release phase.
- Closing speed** After the stop command, this parameter sets the motor speed at which the “Brake contactor control” digital output is disabled.
- Torque delay** The time, after the start command, within which the brake released feedback must be received. If the transient phase is not completed within the time limit set in this parameter, the “Brake error” alarm condition is signalled. In the closing phase the Torque delay is set to 1 second.
- Torque proving** Current capable of supporting the load the drive must guarantee before the brake is released (as a percentage with respect to FLC). It can be set from a parameter and from an analog input set as Brake Ref (32).
- Actuator delay** Delay at the end of the transient release phase, from receiving the signal to confirm that the brake has been released until the motor actually starts to run.

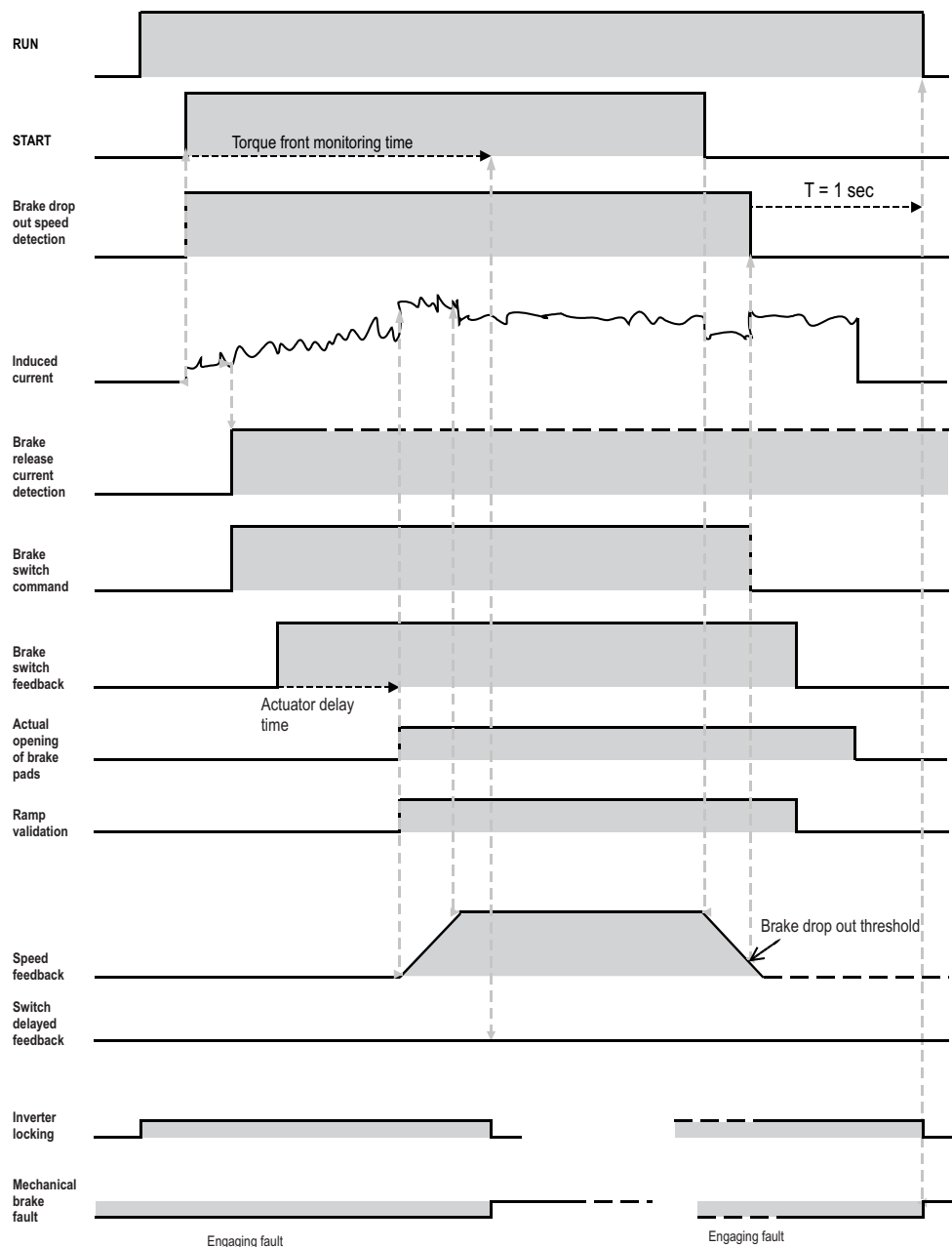

Figure 6.14.8.1: Diagram of control

## Diagram of control

Functional diagram with minimal use of inputs and outputs. Specific assignments of this diagram:

- DI1: Fwd sign Ascending, conventionally "Forward"
- DI2 : Rev sign Descending, conventionally "Reverse"
- DI3: Brake fbk Brake contactor feedback
- Relay 2: Brake command KM10 contactor command

With reference to the previous graph, a brake alarm condition occurs if:

- **when the brake is released**, following the Enable and Start commands, the current is not adequate to support the load (indicated by the Torque proving parameter and signalled by the Brake command digital output) within less than the Torque delay time; or, when the current is adequate, the brake released confirmation input (Brake fbk) is not received, again within the Torque delay time.

- **when the brake is closed**, once the Closing speed (signalled by the Brake command digital output) has been reached, the input signal (Brake fbk) is not sent within less than 1 second.

If no brake feedback (**Brake fbk**) has been set the sequence continues without the test and no alarm is triggered.

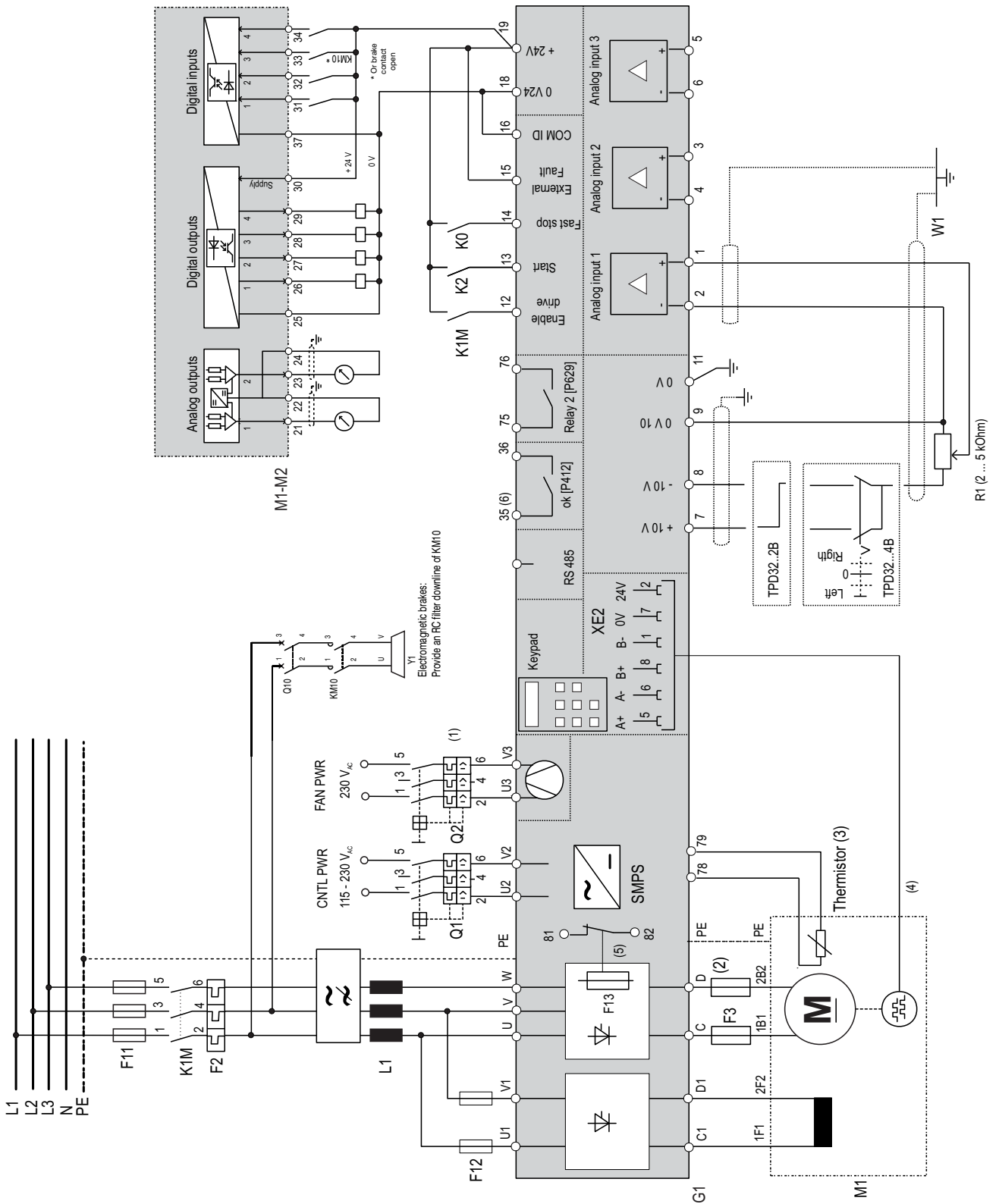

Figure 6.14.8.2: Brake control diagram

## 6.14.9 Current limitation according to the speed (I/n curve)

| FUNCTIONS |                 |
|-----------|-----------------|
|           | I/n curve       |
| [750]     | I/n curve       |
| [751]     | I/n lim 0 [%]   |
| [752]     | I/n lim 1 [%]   |
| [753]     | I/n lim 2 [%]   |
| [754]     | I/n lim 3 [%]   |
| [755]     | I/n lim 4 [%]   |
| [756]     | I/n speed [rpm] |

This function allows the changing of the current limits “In use Tcur lim + / -“ according to the motor speed, through a curve composed by six setpoints. The “I/n speed” and “I/n lim 0,1,2,3,4” are the parameters that allow to define the curve.

| Parameter description                    | No. | Value |      |                  |                  | Standard Configuration |
|--|-----|-------|------|------------------|------------------|------------------------|
|  |     | min   | max  | Factory American | Factory European |                        |
| I/n curve<br>Enabled (1)<br>Disabled (0) | 750 | 0     | 1    | 0                | 0                | -                      |
| I/n lim 0 [%]                            | 751 | 0     | 200  | 0                | 0                | -                      |
| I/n lim 1 [%]                            | 752 | 0     | 200  | 0                | 0                | -                      |
| I/n lim 2 [%]                            | 753 | 0     | 200  | 0                | 0                | -                      |
| I/n lim 3 [%]                            | 754 | 0     | 200  | 0                | 0                | -                      |
| I/n lim 4 [%]                            | 755 | 0     | 200  | 0                | 0                | -                      |
| I/n speed [rpm]                          | 756 | 0     | P162 | 0                | 0                | -                      |

“I/n speed” parameter defines the speed range in which the current limits are kept at the value of “I/n lim 0”. The speed range included between “I/n speed” and the 100% of the max. speed will be divided internally in four equal segments, at the ends of which the current limits “I/n lim 0,1,2,3,4” are associated. The set values must decrease, starting from “I/n lim 0” up to “I/n lim 4”.

- I/n curve** Enabled Limits current /speed curve enabled  
Disabled Limits current /speed curve disabled
- I/n lim 0** Current limit of the I/n curve that operates constantly up to the speed set by the “I/n speed” parameter.
- I/n lim 1** First current limit which states the Taper current curve construction.
- I/n lim 2** Second current limit which states the curve construction.
- I/n lim 3** Third current limit which states the curve construction.
- I/n lim 4** Fourth current limit which states the curve construction.
- I/n speed** Threshold speed at which torque reduction starts.

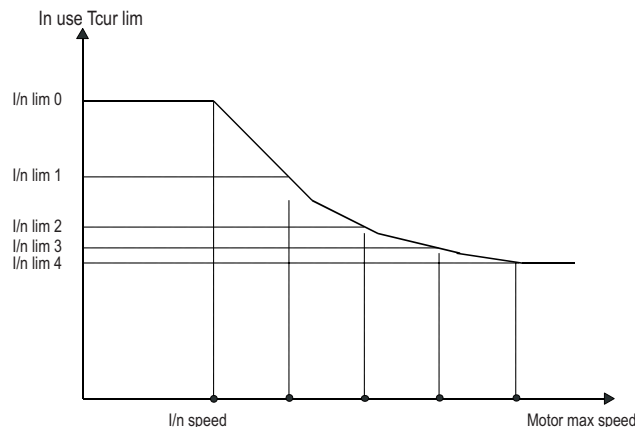

Figure 6.14.9.1 Current limitation according to the speed



## 6.15 SPEC FUNCTIONS

### 6.15.1 Test generator

| SPEC FUNCTIONS |                       |
|----------------|-----------------------|
|                | <b>Test generator</b> |
| [58]           | Generator access      |
| [59]           | Gen frequency [Hz]    |
| [60]           | Gen amplitude [%]     |
| [61]           | Generator offset [%]  |

| Parameter description  | No. | Value   |         |                  |                  | Standard Configuration |
|--|-----|---------|---------|------------------|------------------|------------------------|
|  |     | min     | max     | Factory American | Factory European |                        |
| <b>Generator access</b><br>Not connected (0)<br>T current ref (2)<br>Flux ref (3)<br>Ramp ref (4)<br>Speed ref (5) | 58  | 0       | 5       | Not conn.        | Not conn.        |                        |
| <b>Gen frequency [Hz]</b>  | 59  | 0.1     | 62.5    | 0.1              | 0.1              |                        |
| <b>Gen amplitude [%]</b>   | 60  | 0       | 200.00  | 0                | 0                |                        |
| <b>Generator offset [%]</b>  | 61  | -200.00 | +200.00 | 0                | 0                |                        |

The test generator of the TPD32 converter is used to manual tune the regulators. It consists of a square wave generator whose frequency, offset and amplitude can be set. The output signal of the “Test Generator” can be set on a programmable analog output.

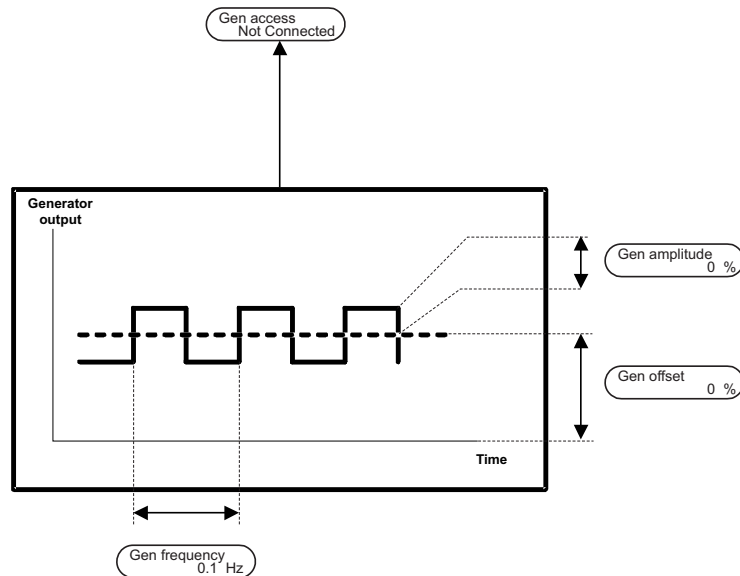

Figure 6.15.1.1: Test generator output

- Gen access** Different parameters can be simulated by the test generator. The parameter concerned then has the value of the generator output.
- Gen frequency** Output frequency of the generator in Hz.
- Gen amplitude** Amplitude of the square-wave signal produced by the generator in percent.
- Generator offset** Offset of the generator in percent.

The generator output consists of the addition of **Gen amplitude** and **Generator offset**.

## 6.15.2 Saving parameters, loading default factory settings, life time

### SPEC FUNCTIONS

|       |                   |
|-------|-------------------|
| [256] | Save parameters   |
| [258] | Load default      |
| [235] | Life time [h.min] |

| Parameter description | No. | Value |          |                  |                  | Standard Configuration |
|-----------------------|-----|-------|----------|------------------|------------------|------------------------|
|                       |     | min   | max      | Factory American | Factory European |                        |
| Save parameters       | 256 |       |          |                  |                  | -                      |
| Load default          | 258 |       |          |                  |                  | -                      |
| Life time [h.min]     | 235 | 0.00  | 65535.00 |                  |                  | -                      |

**Save parameters** Saving of parameters that are currently set by the user. This command can also be given from keypad, when “Bus” through the Control mode parameter, has been selected.

**Load default** Loading of the default settings (“Factory” column in the parameter table).

**Life time** Shows the operating time of the converter. This parameter counts the time in which the converter is powered on (even if disabled).

Default values for individual parameters are factory set in the device. These values are shown in the “Factory” column of the individual parameter tables. In order to obtain the values specific to your application when the device is switched on, they must be saved via the Save parameters command after being set.

The factory default values can be re-loaded by selecting **Load default**. If these are not saved, the application specific drive settings will still be available the next time the drive is switched on.

When the device is switched on the saved parameter set is loaded.

**Note!** The **Tacho scale** and **Speed offset** parameters are used for the fine scaling of the speed feedback circuit. When the factory set parameters are loaded (**Load Default**) these two parameters do not change, so that a new scaling is not required!

## 6.15.3 Failure Register

### SPEC FUNCTIONS

|       |                  |
|-------|------------------|
| [330] | Failure register |
| [262] | Failure reset    |
| [263] | Failure reg del  |

| Parameter description | No. | Value |     |                  |                  | Standard Configuration |
|-----------------------|-----|-------|-----|------------------|------------------|------------------------|
|                       |     | min   | max | Factory American | Factory European |                        |
| Failure register      | 330 | 1     | 10  | 10               | 10               | -                      |
| Failure reset         | 262 |       |     |                  |                  | -                      |
| Failure reg del       | 263 |       |     |                  |                  | -                      |

**Failure register** The Failure register contains the last 10 failures that have occurred. It also contains information about the time the failure occurred, based on the operating hours (**Life time**), as well as information on the type of failure. This information can be accessed by pressing the ENTER key on the keypad when a failure is indicated. If several failures occur in sequence, all the failures are stored in the failure register until a failure occurs that causes the disconnection of the drive (Latch = ON, see Programmable alarms). The content of the failure register can also be read out via the bus or the serial interface.

**Failure reset** Acknowledgement of a failure. The failure reset can be initiated by pressing the CANCEL key when the failure is shown in the display of the keypad. If, however, several failures occur in sequence, these can only be reset by selecting **Failure reset** command through the ENT key.

**Failure reg del** Clearing the failure register.

The informations about the last 10 failures that have occurred are available thru serial line in the following way:

- Set the parameter FAILURE REGISTER [330], it indicates the position number of the failure occurred: Example, if set to 10 it will be the last failure.
- Read: FAILURE TEXT [327], FAILURE HOUR [328], FAILURE MIN [329], they indicate the type and when the alarm is occurred

## 6.15.4 Signal adaptation

| SPEC FUNCTIONS |        |        |        |        |               |
|----------------|--------|--------|--------|--------|---------------|
| Links          |        |        |        |        |               |
| Link 1         |        |        |        |        |               |
| [484]          |        |        |        |        | Source        |
| [485]          |        |        |        |        | Destination   |
| [486]          |        |        |        |        | Mul gain      |
| [487]          |        |        |        |        | Div gain      |
| [488]          |        |        |        |        | Input max     |
| [489]          |        |        |        |        | Input min     |
| [490]          |        |        |        |        | Input offset  |
| [491]          |        |        |        |        | Output offset |
| [492]          |        |        |        |        | Inp absolute  |
| Link 2 ... 6   |        |        |        |        |               |
| [553]          | [1218] | [1227] | [1236] | [1245] | Source        |
| [554]          | [1219] | [1228] | [1237] | [1246] | Destination   |
| [555]          | [1220] | [1229] | [1238] | [1247] | Mul gain      |
| [556]          | [1221] | [1230] | [1239] | [1248] | Div gain      |
| [557]          | [1222] | [1231] | [1240] | [1249] | Input max     |
| [558]          | [1223] | [1232] | [1241] | [1250] | Input min     |
| [559]          | [1224] | [1233] | [1242] | [1251] | Input offset  |
| [560]          | [1225] | [1234] | [1243] | [1252] | Output offset |
| [561]          | [1226] | [1235] | [1244] | [1253] | Inp absolute  |

| Parameter description    | Link 1 | Link 2 | Link 3 | Link 4 | Link 5 | Link 6 | Value  |        |                  |                  | Standard Configuration |
|--------------------------|--------|--------|--------|--------|--------|--------|--------|--------|------------------|------------------|------------------------|
|                          | No.    | No.    | No.    | No.    | No.    | No.    | min    | max    | Factory American | Factory European |                        |
| Source                   | 484    | 553    | 1218   | 1227   | 1236   | 1245   | 0      | 65535  | 0                | 0                | -                      |
| Destination              | 485    | 554    | 1219   | 1228   | 1237   | 1246   | 0      | 65535  | 0                | 0                | -                      |
| Mul gain                 | 486    | 555    | 1220   | 1229   | 1238   | 1247   | -10000 | +10000 | 1                | 1                | -                      |
| Div gain                 | 487    | 556    | 1221   | 1230   | 1239   | 1248   | -10000 | +10000 | 1                | 1                | -                      |
| Input max                | 488    | 557    | 1222   | 1231   | 1240   | 1249   | -231   | 231-1  | 0                | 0                | -                      |
| Input min                | 489    | 558    | 1223   | 1232   | 1241   | 1250   | -231   | 231-1  | 0                | 0                | -                      |
| Input offset             | 490    | 559    | 1224   | 1233   | 1242   | 1251   | -231   | 231-1  | 0                | 0                | -                      |
| Output offset            | 491    | 560    | 1225   | 1234   | 1243   | 1252   | -231   | 231-1  | 0                | 0                | -                      |
| Inp absolute<br>OFF / ON | 492    | 561    | 1226   | 1235   | 1244   | 1253   | 0      | 1      | OFF              | OFF              | -                      |

The Link1 and Link 6 functions are two control section operating independently of each other for the signal adaptation. With the Links, parameters can be: rectified, limited, multiplied by a factor, divided by a factor and provided with an offset.

|                      |   |
|----------------------|---|
| <b>Source</b>        | Parameter number used as an input quantity. For example “8236” for the <b>Ramp ref 1</b> parameter (44+8192 offset). Select the parameter number in the individual descriptions or in the list of all parameters in section 10, “Parameter list”. |
| <b>Destination</b>   | Parameter number, which determines the output quantity. Select the parameter number (+8192 offset) in the individual description column or in the list of all parameters in section 10, “Parameter lists”.  |
| <b>Mul gain</b>      | Multiplicative factor of the input quantity (after a possible limitation). Resolution: 5 digits.  |
| <b>Div gain</b>      | Divisor, through which it is possible to divide the input quantity already multiplied and limited. Resolution: 5 digits.  |
| <b>Input max</b>     | Max. limit of the input quantity. Resolution: 5 digits.   |
| <b>Input min</b>     | Min. limit of the input quantity. Resolution: 5 digits.   |
| <b>Input offset</b>  | Offset to be added to the input quantity. Resolution: 5 digits.   |
| <b>Output offset</b> | Offset to be added to the output quantity. Resolution: 5 digits.  |

**Inp absolute**

The input behavior can be determined with this parameter.

OFF

The input quantity is processed with its sign.

ON

The input quantity is processed with a positive sign (absolute value). It is possible to have a polarity change with the signs of **Mul gain** or **Div gain**.

In order to write **SOURCE LINK (1/6) parameter** or **DESTINATION LINK (1/6) parameter** it is necessary to add to the parameter number the offset "8192"

Eg.

**RAMP REF 1 "44"**

**SOURCE LINK (1/2) = 44+8192 = 8236**

**Note!**

The Links are executed with an approximate cycle time of 20 ms. They are not mainly intended to be used for regulation but to access or connect parameters otherwise not accessible. The use of Links according to the parameter chosen as a destination involves a CPU overhead that can slow down the keypad/display operation. Check that the functionality corresponds to the needs before plant-wide implementation.

**Note!**

The following parameters cannot be used as a destination of a Link:

- All parameters with only "R" access code
- All parameters with "Z" access code
- All parameters with "C" access code
- All the following:

|     |                              |     |                                |      |                  |
|-----|------------------------------|-----|--------------------------------|------|------------------|
| 19  | S shape t const              | 474 | Field loss - Restart time      | 665  | S acc t const 0  |
| 55  | Control word                 | 475 | Field loss - Hold off time     | 666  | S dec t const 0  |
| 72  | Scale input 1                | 480 | Speed fbk loss - Hold off time | 667  | S acc t const 1  |
| 73  | Tune value inp 1             | 482 | Overvoltage - Hold off time    | 668  | S dec t const 1  |
| 77  | Scale input 2                | 483 | Overvoltage - Restart time     | 669  | S acc t const 2  |
| 78  | Tune value inp 2             | 484 | Link1 - Source                 | 670  | S dec t const 2  |
| 82  | Scale input 3                | 485 | Link1 - Destination            | 671  | S acc t const 3  |
| 85  | Pword1                       | 501 | External fault - Restart time  | 672  | S dec t const 3  |
| 83  | Tune value inp 3             | 502 | External fault - Hold off time | 776  | PI central V1    |
| 86  | Password2                    | 553 | Link2 - Source                 | 785  | PI bottom lim    |
| 318 | Overload mode                | 554 | Link2 - Destination            | 786  | PID source       |
| 408 | Ser answer delay             | 562 | Tacho scale                    | 792  | Input 1 filter   |
| 425 | Enable OPT2                  | 585 | Overcurrent - Restart time     | 1012 | Inertia c filter |
| 444 | Prop. Filter                 | 586 | Overcurrent - Hold off time    | 1013 | Torque const     |
| 453 | Arm resistance               | 636 | Bus loss - Hold off time       | 1014 | Inertia          |
| 454 | Arm inductance               | 637 | Bus loss - Restart time        | 1015 | Friction         |
| 456 | Flux weak speed              | 649 | Refresh enc 1                  | 1042 | Input 1 compare  |
| 467 | Flux current max             | 652 | Refresh enc 2                  | 1043 | Input 1 cp error |
| 468 | Flux current min             | 663 | S acc t const                  | 1044 | Input 1 cp delay |
| 470 | Undervoltage - Hold off time | 664 | S dec t const                  |      |                  |

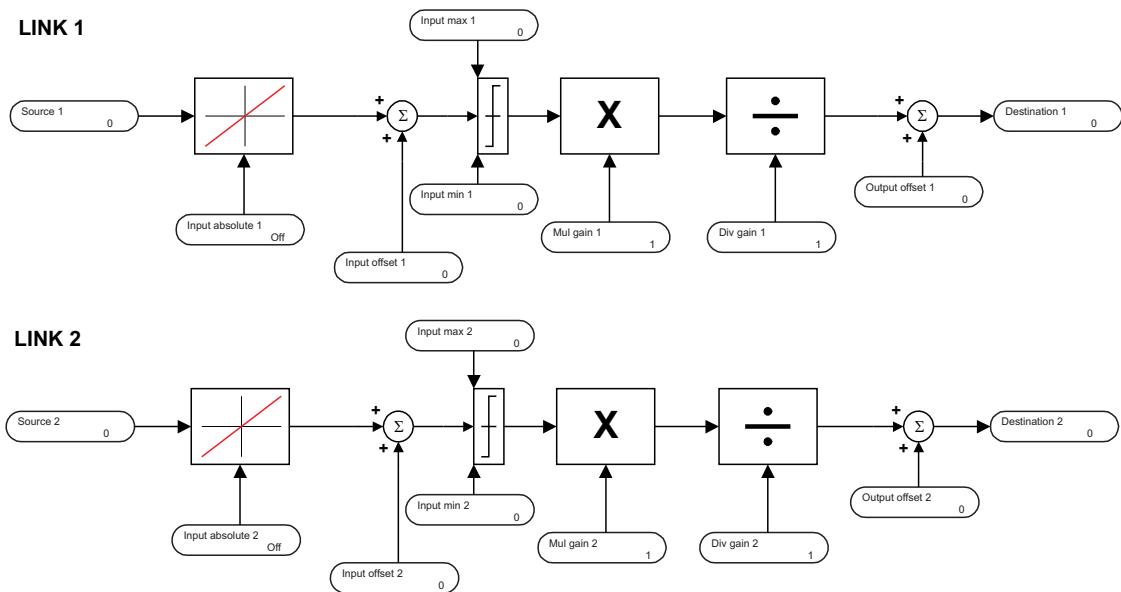

Figure 6.15.4.1: Structure of the signal adaptation

## 6.15.5 Pads

The pads are used for the data exchange among the several components of a Bus system. They can be compared to the variables of a PLC. The figure 6.15.5.1 shows the overall structure of the system. With the help of pads it is possible for example to send information from a field Bus to an option card. All the pads can be written and read. See the several access possibilities in section 10, "Parameter list".

### SPEC FUNCTIONS

#### Pad Parameters

|       |               |
|-------|---------------|
| [503] | Pad 0         |
| [504] | Pad 1         |
| [505] | Pad 2         |
| [506] | Pad 3         |
| [507] | Pad 4         |
| [508] | Pad 5         |
| [509] | Pad 6         |
| [510] | Pad 7         |
| [511] | Pad 8         |
| [512] | Pad 9         |
| [513] | Pad 10        |
| [514] | Pad 11        |
| [515] | Pad 12        |
| [516] | Pad 13        |
| [517] | Pad 14        |
| [518] | Pad 15        |
| [519] | Bitword pad A |
| [536] | Bitword pad B |

| Parameter description | No. | Value  |        |                  |                  | Standard Configuration |
|-----------------------|-----|--------|--------|------------------|------------------|------------------------|
|                       |     | min    | max    | Factory American | Factory European |                        |
| Pad 0                 | 503 | -32768 | +32767 | 0                | 0                | * **                   |
| Pad 1                 | 504 | -32768 | +32767 | 0                | 0                | * **                   |
| Pad 2                 | 505 | -32768 | +32767 | 0                | 0                | *                      |
| Pad 3                 | 506 | -32768 | +32767 | 0                | 0                | *                      |
| Pad 4                 | 507 | -32768 | +32767 | 0                | 0                | **                     |
| Pad 5                 | 508 | -32768 | +32767 | 0                | 0                | **                     |
| Pad 6                 | 509 | -32768 | +32767 | 0                | 0                | -                      |
| Pad 7                 | 510 | -32768 | +32767 | 0                | 0                | -                      |
| Pad 8                 | 511 | -32768 | +32767 | 0                | 0                | -                      |
| Pad 9                 | 512 | -32768 | +32767 | 0                | 0                | -                      |
| Pad 10                | 513 | -32768 | +32767 | 0                | 0                | -                      |
| Pad 11                | 514 | -32768 | +32767 | 0                | 0                | -                      |
| Pad 12                | 515 | -32768 | +32767 | 0                | 0                | -                      |
| Pad 13                | 516 | -32768 | +32767 | 0                | 0                | -                      |
| Pad 14                | 517 | -32768 | +32767 | 0                | 0                | -                      |
| Pad 15                | 518 | -32768 | +32767 | 0                | 0                | -                      |
| Bitword pad A         | 519 | 0      | 65535  | 0                | 0                | *** **                 |
| Pad A Bit 0           | 520 | 0      | 1      | 0                | 0                | *** **                 |
| Pad A Bit 1           | 521 | 0      | 1      | 0                | 0                | *** **                 |
| Pad A Bit 2           | 522 | 0      | 1      | 0                | 0                | *** **                 |
| Pad A Bit 3           | 523 | 0      | 1      | 0                | 0                | *** **                 |
| Pad A Bit 4           | 524 | 0      | 1      | 0                | 0                | *** **                 |
| Pad A Bit 5           | 525 | 0      | 1      | 0                | 0                | *** **                 |
| Pad A Bit 6           | 526 | 0      | 1      | 0                | 0                | *** **                 |
| Pad A Bit 7           | 527 | 0      | 1      | 0                | 0                | *** **                 |
| Pad A Bit 8           | 528 | 0      | 1      | 0                | 0                |                        |
| Pad A Bit 9           | 529 | 0      | 1      | 0                | 0                |                        |
| Pad A Bit 10          | 530 | 0      | 1      | 0                | 0                |                        |
| Pad A Bit 11          | 531 | 0      | 1      | 0                | 0                |                        |
| Pad A Bit 12          | 532 | 0      | 1      | 0                | 0                |                        |
| Pad A Bit 13          | 533 | 0      | 1      | 0                | 0                |                        |
| Pad A Bit 14          | 534 | 0      | 1      | 0                | 0                | *****                  |
| Pad A Bit 15          | 535 | 0      | 1      | 0                | 0                |                        |
| Bitword pad B         | 536 | 0      | 65535  | 0                | 0                | ****                   |
| Pad B Bit 0           | 537 | 0      | 1      | 0                | 0                | ****                   |
| Pad B Bit 1           | 538 | 0      | 1      | 0                | 0                | ****                   |
| Pad B Bit 2           | 539 | 0      | 1      | 0                | 0                | ****                   |
| Pad B Bit 3           | 540 | 0      | 1      | 0                | 0                | ****                   |
| Pad B Bit 4           | 541 | 0      | 1      | 0                | 0                | ****                   |
| Pad B Bit 5           | 542 | 0      | 1      | 0                | 0                | ****                   |
| Pad B Bit 6           | 543 | 0      | 1      | 0                | 0                | ****                   |
| Pad B Bit 7           | 544 | 0      | 1      | 0                | 0                | ****                   |
| Pad B Bit 8           | 545 | 0      | 1      | 0                | 0                |                        |
| Pad B Bit 9           | 546 | 0      | 1      | 0                | 0                |                        |

|                     |     |   |   |   |   |       |
|---------------------|-----|---|---|---|---|-------|
| <b>Pad B Bit 10</b> | 547 | 0 | 1 | 0 | 0 |       |
| <b>Pad B Bit 11</b> | 548 | 0 | 1 | 0 | 0 |       |
| <b>Pad B Bit 12</b> | 549 | 0 | 1 | 0 | 0 |       |
| <b>Pad B Bit 13</b> | 550 | 0 | 1 | 0 | 0 |       |
| <b>Pad B Bit 14</b> | 551 | 0 | 1 | 0 | 0 | ***** |
| <b>Pad B Bit 15</b> | 552 | 0 | 1 | 0 | 0 |       |

- \* These parameters can be set on a programmable analog inputs.
- \*\* These parameters can be set on a programmable analog output.
- \*\*\* These parameters can be set on a programmable digital input.
- \*\*\*\* These parameters can be set on a programmable digital output.
- \*\*\*\*\* These parameters can be set on Relay 2.

**Pad 0...15**

General variables, 16 Bit. The Pads 0...3 can be set via analog inputs. The values of the Pads 0, 1, 4, 5 and 6 can be set on analog outputs.

**Bitword pad A (B)**

Bitmap of the parameters **Pad A (B)** bit 0 up to **Pad A (B) bit 15**. With a parameter it is possible to read or write all the Bits inside a Word.

Example:

|              |   |                   |        |
|--------------|---|-------------------|--------|
| Pad A bit 0  | 0 |                   |        |
| Pad A bit 1  | 1 | = 2 <sup>1</sup>  | = 2    |
| Pad A bit 2  | 0 |                   |        |
| Pad A bit 3  | 0 |                   |        |
| Pad A bit 4  | 0 |                   |        |
| Pad A bit 5  | 1 | = 2 <sup>5</sup>  | = 32   |
| Pad A bit 6  | 1 | = 2 <sup>6</sup>  | = 64   |
| Pad A bit 7  | 0 |                   |        |
| Pad A bit 8  | 0 |                   |        |
| Pad A bit 9  | 0 |                   |        |
| Pad A bit 10 | 1 | = 2 <sup>10</sup> | = 1024 |
| Pad A bit 11 | 0 |                   |        |
| Pad A bit 12 | 1 | = 2 <sup>12</sup> | = 4096 |
| Pad A bit 13 | 0 |                   |        |
| Pad A bit 14 | 0 |                   |        |
| Pad A bit 15 | 0 |                   |        |

Bitword pad A = 2 + 32 + 64 + 1024 + 4096 = 5218

**Pad A (B) bit 0...15**

Bit variables. The single Bits can be read or written. With the **Bitword pad A (B)** it is possible to process a Word. See the example. From the Pad A it is possible to read the Bits 0.....7 of a digital input. On a digital output it is possible to write all the Bit.

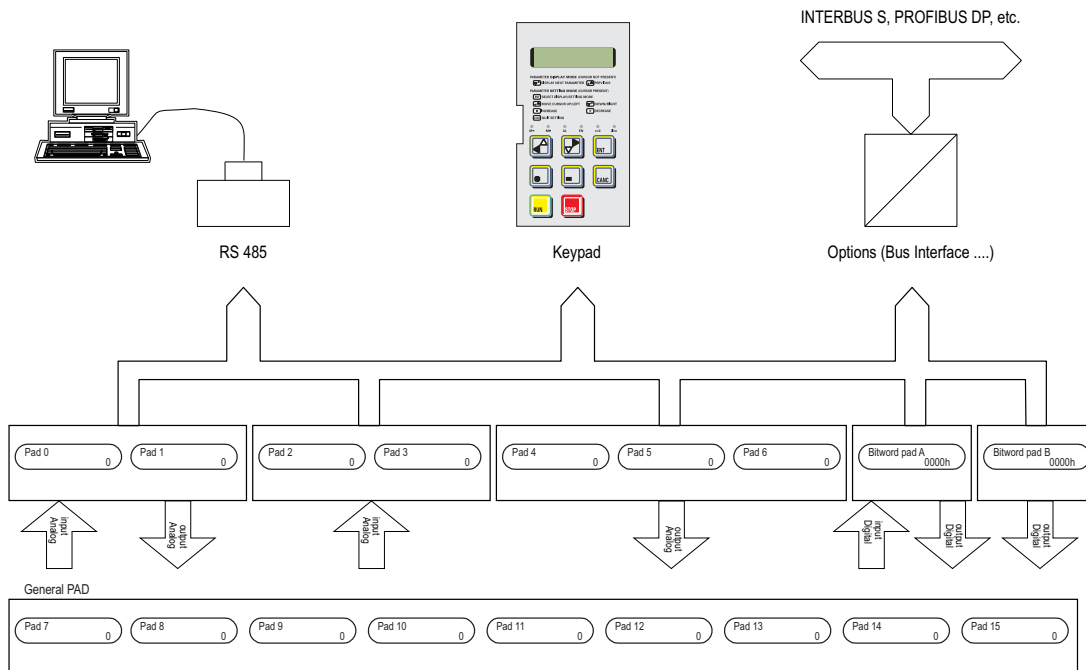

Figure 6.15.5.1: Bus pads

**Note**

When setting the PADS bit to digital I/O the following rules have to be applied:

1. Assigning PAD A/B bit to a Digital Output will cause the state of the digital output (n) coming from PAD A/B bit (n-1)
2. Relay 2 can be driven by means of PAD A/B bit 14.

## 6.16 OPTIONS

### 6.16.1 Option 1

| OPTIONS |          |
|---------|----------|
|         | Option 1 |
|         | Menu     |

Through this menu the assignment of Drive parameters to the virtual digital I/O (MONITOR\Virtual digital Inp-Out menu) and to the process data channels (PDC) of the field bus can be carried out.

If the bus card is not present you will be prompted (inside the menu) by the message **OPT1 not present**.

If the used bus card is not up-to-date for this management, you will be prompted (inside the menu) by the message **OPT1 old version**.

For further and detailed information, refer to the bus interface instruction book.

### 6.16.2 Option 2

| OPTIONS |                   |
|---------|-------------------|
|         | Option 2          |
|         | Menu              |
|         | [425] Enable OPT2 |

| Parameter description                      | No. | Value |     |                  |                  | Standard Configuration |
|--|-----|-------|-----|------------------|------------------|------------------------|
|  |     | min   | max | Factory American | Factory European |                        |
| Menu                                       |     |       |     |                  |                  |                        |
| Enable OPT2<br>Enabled (1)<br>Disabled (0) | 425 | 0     | 1   | Disable          | Disable          |                        |

This menu allows the user access to the parameter set of the APC200 option card.

**Menu** The menu is active only if the OPT2 card is present (e.g. a APC200 card). If the user tries to enter in the Option 2 menu and the card is not mounted on the device the message “Not present” is displayed.

For further and detailed information see the instruction book of the optional board.

**Enable OPT2** Enabled When the converter is switched on, the presence of the APC200 card is checked. If the card is present, the “Menu” parameters are started and the APC200 parameters can be reached.

Disabled When the converter is switched on, the presence of the APC200 card is not checked. Therefore, the option parameters are not taken into consideration even though the card is present.

Default configuration = Disabled.

To change the configuration:

- 1 - set the new value of **Enable OPT2** parameter
- 2 - store via the **Save parameters** (BASIC MENU)
- 3 - switch-off and switch-on the drive

If Enabled and the APC200 card is not present, will be generated the error: **OPT2 failure code 100-98 or OPT2 failure code 100-96**.

**Note**

When using the APC200 card (Option 2), all parameters listed in the “Opt2-A/PDC” column of Parameter List (section 10.1 and 10.2) can be accessed through the automatic asynchronous communication. Parameters listed in the High Priority Parameter List (section 10.4) can be accessed by means of the automatic synchronous communication. (See APC200 manual for more details.)

If the software has detected the presence of the APC200 the parameter set of the optional card is accessible. In this case see the APC200 user manual for detailed information.



### 6.16.3 PID Function

| OPTIONS               |                       |
|-----------------------|-----------------------|
| <b>PID</b>            |                       |
| [769]                 | Enable PI PID         |
| [770]                 | Enable PD PID         |
| <b>PID source</b>     |                       |
| [786]                 | PID source            |
| [787]                 | PID source gain       |
| [758]                 | Feed-fwd PID          |
| <b>PID references</b> |                       |
| [759]                 | PID error             |
| [763]                 | PID feed-back         |
| [762]                 | PID offs. Sel         |
| [760]                 | PID offset 0          |
| [761]                 | PID offset 1          |
| [1046]                | PID acc time          |
| [1047]                | PID dec time          |
| [757]                 | PID clamp             |
| <b>PI controls</b>    |                       |
| [765]                 | PI P gain PID         |
| [764]                 | PI I gain PID         |
| [695]                 | PI steady thr         |
| [731]                 | PI steady delay       |
| [793]                 | P init gain PID       |
| [734]                 | I init gain PID       |
| [779]                 | PI central v sel      |
| [776]                 | PI central v1         |
| [777]                 | PI central v2         |
| [778]                 | PI central v3         |
| [784]                 | PI top lim            |
| [785]                 | PI bottom lim         |
| [783]                 | PI integr freeze      |
| [771]                 | PI output PID         |
| [418]                 | Real FF PID           |
| <b>PD control</b>     |                       |
| [768]                 | PD P gain 1 PID [%]   |
| [766]                 | PD D gain 1 PID [%]   |
| [788]                 | PD P gain 2 PID [%]   |
| [789]                 | PD D gain 2 PID [%]   |
| [790]                 | PD P gain 3 PID [%]   |
| [791]                 | PD D gain 3 PID [%]   |
| [767]                 | PD D filter PID [ms]  |
| [421]                 | PD output PID         |
| [772]                 | PID out sign PID      |
| [774]                 | PID output            |
| <b>PID target</b>     |                       |
| [782]                 | PID target            |
| [773]                 | PID out scale         |
| <b>Diameter calc</b>  |                       |
| [794]                 | Diameter calc         |
| [795]                 | Positioning spd [rpm] |
| [796]                 | Max deviation         |
| [797]                 | Gear box ratio        |
| [798]                 | Dancer constant [mm]  |
| [799]                 | Minimum diameter [cm] |

### 6.16.3.1 General

The PID function has been developed for general uses which can include nip-roll, winders, unwinders, pressure control of pumps and extruders.

A dancer or a load cell can be used as position/tension transducer.

The inputs (with the exception of those concerning the transducers) and the outputs can be configured, they can be associated to various converter parameters. E.g. the PID output can be sent to the speed or to current regulator.

The analog inputs/outputs will be sampled/updated to 2ms.

The digital inputs/outputs will be sampled/updated to 8ms.

**Note!** PID function in the firmware can not be used when the APC200 card is present.

### 6.16.3.2 Inputs / Outputs

#### Regulation Inputs/outputs

|                          |   |
|--------------------------|---|
| <b>PID source</b>        | Sample parameter of Feed-forward normally programmed on analog input.   |
| <b>PID feed-back</b>     | Analog input of position / tension transducer (dancer/load cell).<br>PID feed-back must be programmed on the analog input 1 (terminals 1-2) because of the input filter provided.   |
| <b>PID offset 0</b>      | Offset analog input added to <b>PID feed-back</b> . Used for the adjustment of the dancer position.   |
| <b>PID target</b>        | Parameter associated with the regulator output. Normally, it will be programmed on the speed reference of the drive.  |
| <b>PID output</b>        | Analog output of the regulator. Used to carry on a reference cascade in multidrives systems.  |
| <b>PI central v3 PID</b> | Initial value setting of the integral component of the regulator (corresponds to initial diameter). It can be programmed on an analog input. E.g. to an ultrasonic transducer used for the diameter measure of a winder/unwinder. |

#### Input Command (programmable on digital inputs)

|                            |   |
|----------------------------|---|
| <b>Enable PI PID</b>       | Enable of the PI (proportional - integral) of the regulator.  |
| <b>Enable PD PID</b>       | Enable of the PD (proportional - derivative) of the regulator.  |
| <b>PI integral freeze:</b> | Freezing of the actual value of the integral component of the regulator.  |
| <b>PID offset sel</b>      | Offset select, in addition to <b>PID feed-back</b> : L = <b>PID offset 0</b> , H = <b>PID offset 1</b> .  |
| <b>PI central v S0</b>     | Used with <b>PI central v S1</b> to select one of four values for the initial integral level (corresponding to initial diameter). Through binary selection. |
| <b>PI central v S1</b>     | Used with <b>PI central v S0</b> to select one of four values for the initial integral level (corresponding to initial diameter). Through binary selection. |
| <b>Diameter calc</b>       | Enable of the initial diameter calculation.   |
| <b>Diameter calc st</b>    | State of the initial diameter calculation (digital output).   |

### 6.16.3.3 Feed - Forward

| PID source |                 |
|------------|-----------------|
| [786]      | PID source      |
| [787]      | PID source gain |
| [758]      | Feed-fwd PID    |

| Parameter description | No. | Value    |         |                  |                  | Standard Configuration |
|-----------------------|-----|----------|---------|------------------|------------------|------------------------|
|                       |     | min      | max     | Factory American | Factory European |                        |
| PID source            | 786 | 0        | 65535   | 0                | 0                |                        |
| PID source gain       | 787 | -100.000 | +100.00 | 1.000            | 1.000            |                        |
| Feed-fwd PID          | 758 | -10000   | +10000  | 0                | 0                | *                      |

\* This parameter can be set on an analog programmable input..

When used , the feed-forward signal represents the main reference of the regulator. Inside the regulator it will be attenuated or amplified by the PID function and sent to the output as reference signal for the drive.

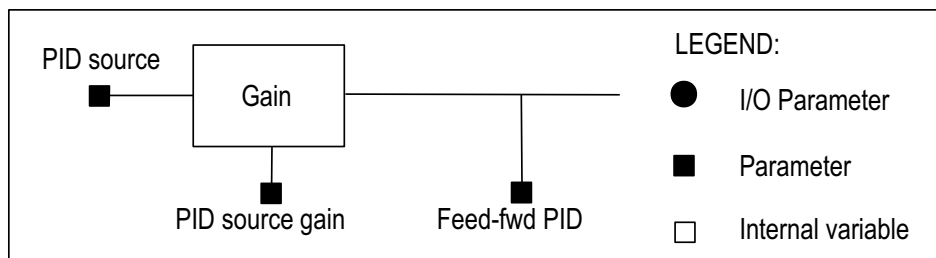

Figure 6.16.3.1: Feed-forward block description

- PID source** Address of the parameter (Feed-forward value) containing the value which will be used as PID source.  
Number +2000H (8192 decimal) must be added to the parameter.
- PID source gain** Multiplier of the input value to PID source.
- Feed-fwd PID** Value of feed-forward

Through the parameter **PID source**, it is possible to select which point in the drive the feed-forward signal may be sent. The selectable parameters are those indicated in the paragraph 10.4. “List of the high-priority parameters”. The measure units are those indicated in the notes at the end of this paragraph.

#### 1. Programming example of the ramp output block (Parameter Ramp out) on PID source:

Menu OPTION

```

_____> PID
_____> PID source
_____> PID source = 8305
  
```

The **PID source** must be set to the parameter number to which it will be associated, choosing it from paragraph 10.4. “List of high-priority parameters” (**Ramp out** has the decimal number 113).

To obtain the value, it must be added to the decimal value 8192 (fixed offset):

$$8192 + 113 = 8305.$$

If you need to set the feed-forward on analog input, given that they are not directly inserted in the ‘high-priority parameters’, it is necessary to pass through a **PAD 0.....PAD 15** parameter.

## 2. Programming example of the analog input 2 on PID source:

- a) Input programming on a PAD parameter  
Menu I/O CONFIG  
    —————> Analog input  
        —————> Analog input 2  
            —————> Select input 2 = PAD 0
- b) Setting of the **PAD 0** as feed-forward input:  
Menu OPTION  
    —————> PID  
        —————> PID source  
            —————> PID source = 8695

The **PID source** must be set to the parameter number to which it will be associated, choosing it from paragraph 10.4 “List of high-priority parameters’ (**PAD 0** has the decimal number 503).

To obtain the value must be added the decimal value 8192 (fixed offset):

$$8192 + 503 = 8695.$$

The full-scale of the feed-forward is limited to the value +/- 10000, which depends on the parameter set on **PID source**. It will be necessary the calibration through **PID gain source**.

The measure units are those indicated in the notes at the end of the paragraph 10.4. “List of the high-priority parameters”.

The feed-forward value can be read through the parameter **Feed-fwd PID** via keypad or serial line.

Referring to the above examples:

### 1. Programming example of the ramp output block (**Parameter Ramp out**) on **PID source**:

Speeds will be converted inside the drive into RPM x 4.

The ramp input references take as maximum set value what set in **Speed base value**.

**Feed - fwd PID = Speed base value x 4 x PID source gain**

If, with max. ramp reference and **Speed base value** = 3000rpm, to have

**Feed - fwd PID** = 10000, it is necessary to set:

$$\mathbf{PID\ source\ gain} = 10000 / (3000 \times 4) = 0.833$$

### 2. Programming for example analog input 2 on **PID source**:

When an analog input will be set on a **PAD** parameter, this will have a max. value of +/- 2047.

With max. analog reference, for having **Feed - fwd PID** = 10000, it is necessary to set:

$$\mathbf{PID\ source\ gain} = 10000 / 2047 = 4.885.$$

#### **Note!**

Using the regulator as “generic PID” without the feed -forward function, **Feed - fwd PID** must be at its max. value.

To do this, it is necessary to set **PID source** on a **PAD** parameter and program it = 10000.

### 6.16.3.4 PID function

The PID function is divided in three blocks:

- Feed-back input “**PID reference**”
- Proportional-integral control block “**PI controls**”
- Proportional-derivative control block “**PD controls**”.

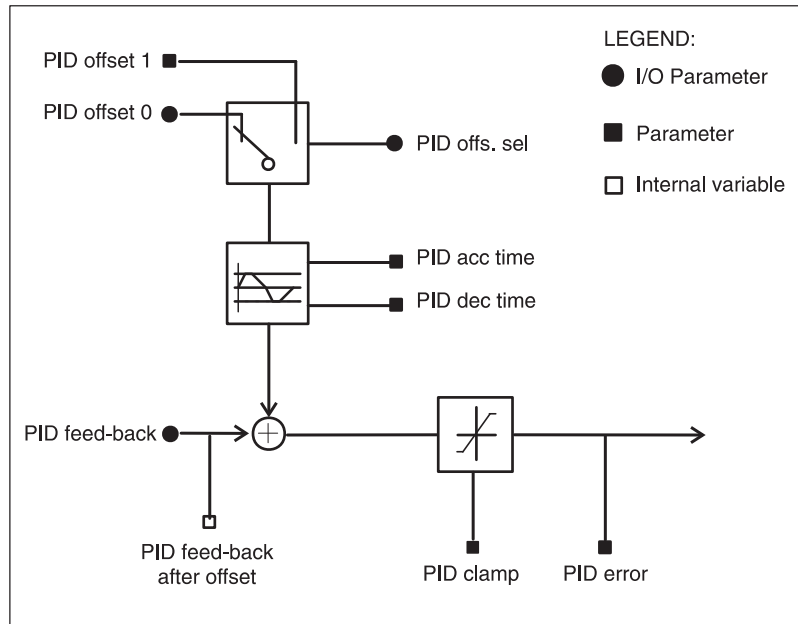

Figure 6.16.3.2: PID blocks description

#### PID references

|        |               |
|--------|---------------|
| [759]  | PID error     |
| [763]  | PID feed-back |
| [762]  | PID offs. Sel |
| [760]  | PID offset 0  |
| [761]  | PID offset 1  |
| [1046] | PID acc time  |
| [1047] | PID dec time  |
| [757]  | PID clamp     |

| Parameter description                                | No.  | Value  |        |                  |                  | Standard Configuration |
|--|------|--------|--------|------------------|------------------|------------------------|
|  |      | min    | max    | Factory American | Factory European |                        |
| <b>PID error</b>                                     | 759  | -10000 | +10000 | 0                | 0                |                        |
| <b>PID feed-back</b>                                 | 763  | -10000 | +10000 | 0                | 0                | **                     |
| <b>PID offs. Sel</b><br>Offset 0 (0)<br>Offset 1 (1) | 762  | 0      | 1      | 0                | 0                | *                      |
| <b>PID offset 0</b>                                  | 760  | -10000 | +10000 | 0                | 0                | **                     |
| <b>PID offset 1</b>                                  | 761  | -10000 | +10000 | 0                | 0                |                        |
| <b>PID acc time</b>                                  | 1046 | 0.0    | 900.0  | 0.0              | 0.0              |                        |
| <b>PID dec time</b>                                  | 1047 | 0.0    | 900.0  | 0.0              | 0.0              |                        |
| <b>PID clamp</b>                                     | 757  | -10000 | +10000 | 10000            | 10000            |                        |

\* This function can be set on a digital programmable input.

\*\* This parameter can be set on an analog programmable input.

|                      |  |
|----------------------|--|
| <b>PID error</b>     | Error reading in the input of the function PID ( <b>PID clamp</b> block output).   |
| <b>PID feed-back</b> | Reading of feed-back value from the transducer position (dancer) or tension (load cell).   |
| <b>PID offs. sel</b> | Offset selector added to <b>PID feed-back</b> . This parameter can be set on a digital programmable input.<br>0 = <b>PID offset 0</b> 1 = <b>PID offset 1</b>  |
| <b>PID offset 0</b>  | Offset 0 added to <b>PID feed-back</b> . This parameter can be set on analog input , E.g. for the tension setting when a load cell has to be used as feed-back.  |
| <b>PID offset 1</b>  | Offset 1 added to <b>PID feed-back</b> .   |
| <b>PID acc time</b>  | Acceleration ramp time value in seconds after the PID offset block.  |
| <b>PID dec time</b>  | Deceleration ramp time value in seconds after the PID offset block.  |
| <b>PID clamp</b>     | The clamp allows a smooth tension setting of a controlled system winder/unwinder, when the “calculation of the initial diameter” function cannot be used.<br>When the drive is enabled, the dancer is at its lower full scale, with <b>PID error</b> at its maximum value. The motor could accelerate to fast in taking the dancer in its central position of work.<br>Setting <b>PID clamp</b> at a value sufficiently low e.g = 1000, at the drive enabling and at the enabling of <b>Enable PD PID</b> , the value of <b>PID error</b> is limited to 1000 until the signal coming from the dancer ( <b>PID feed-back</b> ) does not reach this value. Now <b>PID clamp</b> is automatically take back at its maximum value corresponding to 10000. The clamp is kept at 10000 till the next disabling of the drive or of <b>Enable PD PID</b> . |

The feed - back input is provided for the analog transducers connection like dancer, with relative potentiometer or load cell. Nevertheless, it is possible to use this input block as comparison point between two different analog signals + / - 10V.

#### **Connection to a dancer with potentiometer connected between - 10 and + 10V.**

The wiper of the potentiometer can be connected to one of the analog inputs of the drive. Normally it should be used the analog input 1 (terminals 1 and 2) because it is provided with filter.

The input choosen for that connection must be programmed in the menu I/O CONFIG as **PID feed - back**. Its value can be read in the **PID feed - back** parameter in the **PID REFERENCE** submenu.

Through **PID offset 1** (or PID offset 0), it is possible to carry on the ajustement of the dancer position.

#### **Connection to a load cell with full range + 10V.**

The output of the load cell can be connected to one of the drive analog inputs. Normally the analog input 1 (terminals 1 and 2) should be used because of the filter provided.

The input choosen for the connection must be programmed in the menu I/O CONFIG as **PID feed - back**. Its value can be read in the **PID feed - back** parameter of the **PID REFERENCE** submenu.

The tension setting can be sent, with value 0...-10V, to one of the remaining programmable analog inputs in the **I/O CONFIG** menu as **PID offset 0**.

### 6.16.3.5 Proportional - integral block

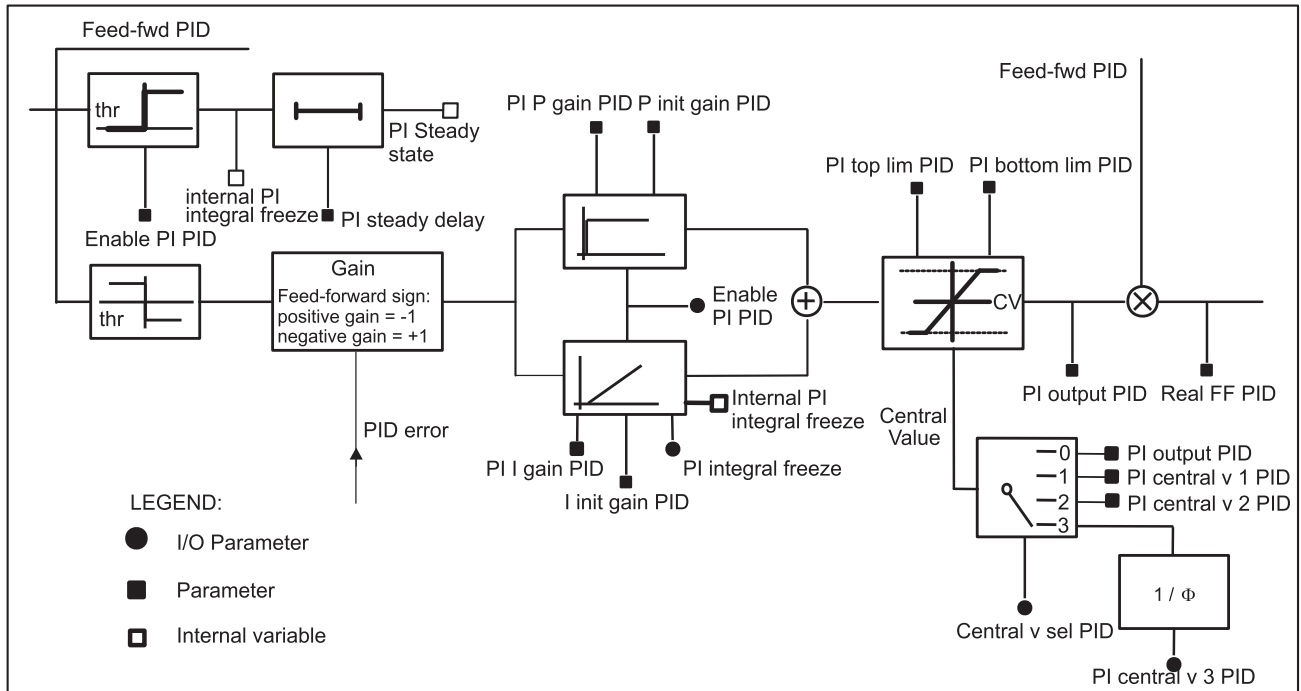

Figure 6.16.3.3: PI block description

The PI block receives its input from the **PID error** parameter, which represents the error that must be corrected by the regulator. The PI block carries on a proportional-integral regulation, its output **PI output PID** after having been appropriately adapted, according to the system which it has to control, it will be used as multiplier factor of the feed-forward (**Feed-fwd PID**) obtaining the correct value of the speed reference for the drive (**Real FF PID**).

The PI block will be enabled setting **Enable PI PID** = Enable. If **Enable PI PID** has been programmed on a digital input, this must be set to a high logic level (+24V).

| PID   |               |
|-------|---------------|
| [769] | Enable PI PID |

| Parameter description                              | No. | Value |     |                  |                  | Standard Configuration |
|--|-----|-------|-----|------------------|------------------|------------------------|
|  |     | min   | max | Factory American | Factory European |                        |
| <b>Menu</b>  |     |       |     |                  |                  |                        |
| <b>Enable PI PID</b><br>Enabled (1) / Disabled (0) | 769 | 0     | 1   | Disable          | Disable          | *                      |

\* This function can be set on a digital programmable input.

|                      |          |   |
|----------------------|----------|---|
| <b>Enable PI PID</b> | Enabled  | Enable of the proportional-integral block   |
|                      | Disabled | Disabling of the proportional-integral blc. |

| PI controls |                  |
|-------------|------------------|
| [765]       | PI P gain PID    |
| [764]       | PI I gain PID    |
| [695]       | PI steady thr    |
| [731]       | PI steady delay  |
| [793]       | P init gain PID  |
| [734]       | I init gain PID  |
| [779]       | PI central v sel |
| [776]       | PI central v1    |
| [777]       | PI central v2    |
| [778]       | PI central v3    |
| [784]       | PI top lim       |
| [785]       | PI bottom lim    |
| [783]       | PI integr freeze |
| [771]       | PI output PID    |
| [418]       | Real FF PID      |

| Parameter description                       | No. | Value         |                     |                  |                  | Standard Configuration |
|---|-----|---------------|---------------------|------------------|------------------|------------------------|
|   |     | min           | max                 | Factory American | Factory European |                        |
| <b>PI P gain PID</b>                        | 765 | 0.00          | 100.00              | 10.00            | 10.00            |                        |
| <b>PI I gain PID</b>                        | 764 | 0.00          | 100.00              | 10.00            | 10.00            |                        |
| <b>PI steady thr</b>                        | 695 | 0             | 10000               | 0                | 0                |                        |
| <b>PI steady delay</b>                      | 731 | 0             | 60000               | 0                | 0                |                        |
| <b>P init gain PID</b>                      | 793 | 0.00          | 100.00              | 10.00            | 10.00            |                        |
| <b>I init gain PID</b>                      | 734 | 0.00          | 100.00              | 10.00            | 10.00            |                        |
| <b>PI central v sel</b>                     | 779 | 0             | 3                   | 1                | 1                | *                      |
| <b>PI central v1</b>                        | 776 | PI bottom lim | PI top lim          | 1.00             | 1.00             |                        |
| <b>PI central v2</b>                        | 777 | PI bottom lim | PI top Lim          | 1.00             | 1.00             |                        |
| <b>PI central v3</b>                        | 778 | PI bottom lim | PI top Lim          | 1.00             | 1.00             | **                     |
| <b>PI top lim</b>                           | 784 | PI bottom lim | 10.00               | 10.00            | 10.00            |                        |
| <b>PI bottom lim</b>                        | 785 | -10.00        | PI top lim          | 0.0              | 0.0              |                        |
| <b>PI integr freeze</b><br>OFF (0) / ON (1) | 783 | 0             | 1                   | 0                | 0                | *                      |
| <b>PI output PID</b>                        | 771 | 0             | 1000 x PI top limit | 1000             | 1000             |                        |
| <b>Real FF PID</b>                          | 418 | -10000        | +10000              | 0                | 0                |                        |

\* This function can be set on a digital programmable input

\*\* This parameter can be set on an analog programmable input

**PI P gain PID** Proportional gain of PI block

**PI I gain PID** Integral gain of PI block

**PI steady thr** Threshold feed-forward survey. If **Feed-fwd PID** is less than **PI steady thr** the integral regulation will be frozen, the proportional gain assumes the value set in **P init gain PID**. When **Feed-fwd PID** overcomes the threshold, the integral regulation with the gain set in **I init gain PID** will be enabled. The PI block will maintain the gains **P init gain PID** and **I init gain PID** for the time preset through **PI steady delay**. Once this delay is over, they will be brought automatically to **PI P gain PID** and **PI I gain PID**.



|                         |   |
|-------------------------|---|
| <b>PI steady delay</b>  | Time for which the gains <b>P init gain PID</b> and <b>I init gain PID</b> have been kept operative after overcoming the feed-forward <b>PI steady thr</b> threshold.<br>The delay time <b>PI steady delay</b> and the resulting function of initial gains changing also, operate on the transition L to H of the <b>Enable PI PID</b> parameter. |
| <b>P init gain PID</b>  | Initial proportional gain. <b>P init gain PID</b> operates when feed-forward is less than <b>PI steady thr</b> and at its overcoming, for the time set in <b>PI steady delay</b> or on the transition L to H of <b>Enable PI PID</b> for the same time.   |
| <b>I init gain PID</b>  | Initial integral gain. <b>I init gain PID</b> operates after the threshold <b>PI steady thr</b> has been overcome or on the transition L to H of <b>Enable PI PID</b> for the time set in <b>PI steady delay</b> .  |
| <b>PI central v sel</b> | Output selector of the starting PI block. <b>PI central v sel</b> (0...3) selects between the 4 possible settings of the initial value of the regulator integral component (corresponding to initial diameter).   |

**PI central v sel** can be set directly from keypad, serial line or through two digital inputs set respectively as **PI central v S0** and **PI central v S1**.

Selecting **PI central v sel = 0**, when PI block is disabled (**Enable PI PID = Disable**), the last value of the integral component calculated (corresponding to roll diameter) is stored. This value is displayed in **PI output PID**. When enabled again, the regulation restarts again from that value. The same functionality is used when switching off the drive. This kind of operation can be used when controlling a winder and it is necessary to stop the machine and disable the drives or even remove AC incoming power from the electrical cabinet.

Selecting **PI central v sel = 1-2-3**, when PI block has been disabled, the value of **PI output PID** will be set at what is programmed in the correspondent parameter (x1000). When the drive is restarted after a power off, the precalculated value will be automatically set only if, when powering up the drive, the digital input programmed as **Enable PI PID** is already set at a high level.

|                       |   |
|-----------------------|---|
| <b>PI central v 1</b> | Setting of the first initial value of the regulator's integral component (corresponding to initial diameter 1). The <b>PI central v 1</b> value must be included in the limits set in <b>PI top lim PID</b> and <b>PI bottom lim PID</b> .<br><b>PI central v 1</b> will be selected by setting <b>PI central v sel = 1</b> .   |
| <b>PI central v 2</b> | Setting of the second initial value of the regulator's integral component (corresponding to initial diameter 2). The <b>PI central v 2</b> value must be included in the limits set in <b>PI top lim PID</b> and <b>PI bottom lim PID</b> .<br><b>PI central v 2</b> will be selected by setting <b>PI central v sel = 2</b> .  |
| <b>PI central v 3</b> | Setting of the third initial value of the regulator's integral component (correspondent to initial diameter 3). The <b>PI central v 1</b> value must be included in the limits given by <b>PI top lim PID</b> and <b>PI bottom lim PID</b> .<br><b>PI central v 3</b> will be selected by setting <b>PI central v sel = 3</b> . |
| <b>PI top lim</b>     | It defines the higher limit of the adapting block of the PI correction.   |
| <b>PI bottom lim</b>  | It defines the lower limit of the adapting block of the PI correction.  |

The output of the PI block represents the multiplier factor of feed-forward, whose value must be adapted from the regulator in the max. limits included between +10000 and -10000 and defined by **PI top lim** and **PI bottom lim**. The value of these parameters will be defined according to the system that has to be controlled. For a better understanding please refer to the paragraph “Examples of application”.

**PI integral freeze** Freezing of the present condition of regulator integral component.

**PI output PID** Output of PI block, adapted to the values included between **PI top limit** and **PI bottom limit**. At the power up of the drive, **PI output PID** acquires automatically the selected value with **PI central v sel** multiplied by 1000.

Example: If **PI central v 2** = 0.5 is selected, at the start **PI output PID** acquires value = 500.

When **Enable PI PID** has been enabled, the output **PI output PID** is, independently on the input error able to integrate its value up to the limits set with **PI top limit** or **PI bottom limit** multiplied by 1000.

Example: **PI top limit** = 2, **PI output PID** max = 2000.

The PI block output will be further limited from the parameter saturation **Real FF PID** (see corresponding parameter). As previously described, **PI output PID** is used as a multiplier factor of the feed-forward in order to obtain the angular speed reference of the motor. If the PID function is used to control a winder/ unwinder system, its value is inversely proportional to the roll diameter. When winding with a constant peripheral speed, the following is valid:

$$\omega_0 \Phi_1 = \omega_1 \Phi_0$$

where:

$\omega_0$  = angular speed at minimum diameter

$\Phi_0$  = minimum diameter

$\omega_1$  = angular speed at actual diameter

$\Phi_1$  = actual diameter

$$\omega_1 = \omega_0 \times (\Phi_0 / \Phi_1)$$

If the drive is set correctly, and  $\omega_0$  is equivalent to the maximum value of the feed-forward, then **PI output PID** depends on  $(\Phi_0 / \Phi_1)$ .

Taking into consideration the internal coefficients of the firmware, it can be written:

$$\text{PI output PID} = (\Phi_0 / \Phi_1) \times 1000$$

This formula can be used to verify the accuracy of the setting when the system is on working or during the procedure for the calculation of the initial diameter.

**Real FF PID** Represents the feed-forward value which has been recalculated according to the PI correction. It will be calculated with the following formula:

$$\text{Real FF PID} = (\text{Feed-fwd PID} / 1000) \times \text{PI output PID}$$

The max. value of **Real FF PID** is +/- 10.000. If this limit had been reached during operation, in order to avoid dangerous levels of regulator saturation, further increases of **PI output PID** will be blocked.

Example: Feed-fwd = + 8000, the positive limit of PI output PID will be automatically set at  $10000 / (8000 / 1000) = 1250$ .

### 6.16.3.6 Proportional - Derivative control block

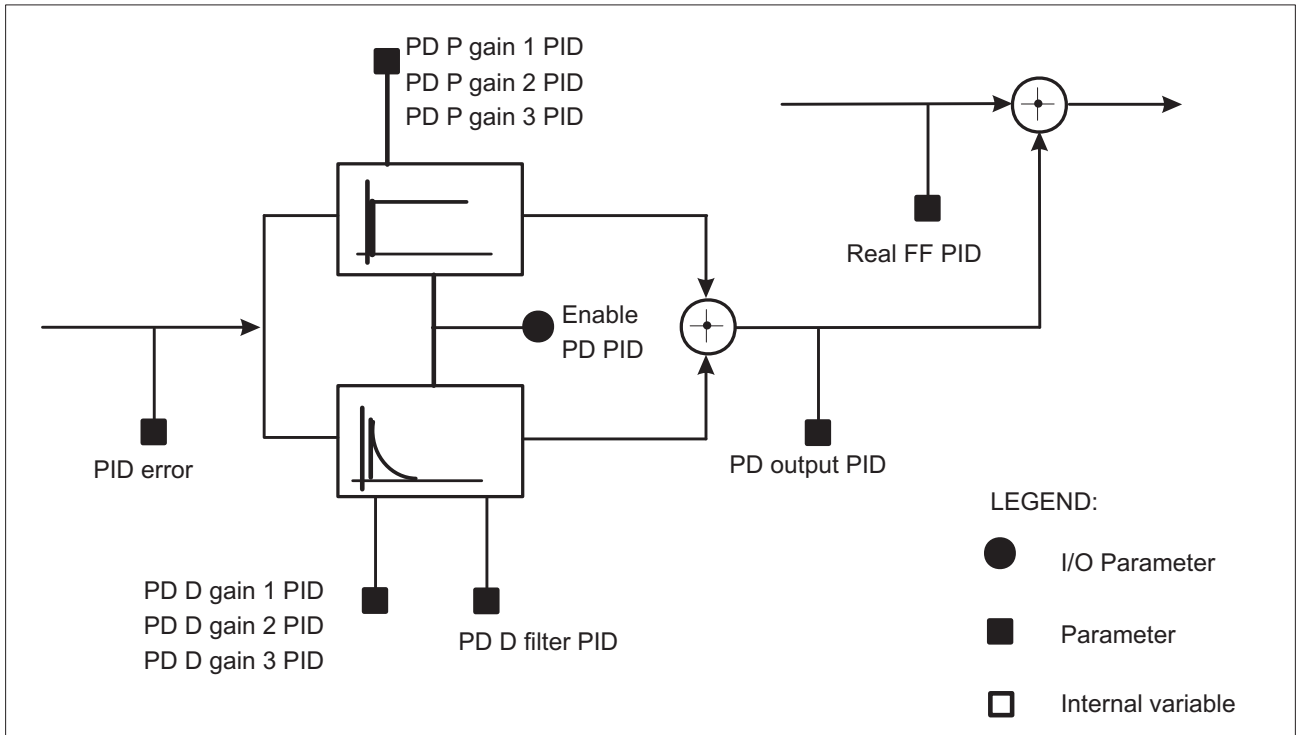

Figure 6.16.3.4: PD block description

The PD block receives the values **PID error** at its input, which represents the error that must be corrected by the regulator. The PD block carries out proportional-derivative regulation and its output **PD output PID** will be added to **Real FF PID**.

The PD block is enabled by setting **Enable PD PID** = Enable. If **Enable PD PID** has been programmed on a digital input, this must be set to a high logical level.

| PID |       |               |
|-----|-------|---------------|
|     | [770] | Enable PD PID |

| Parameter description                              | No. | Value |     |                  |                  | Standard Configuration |
|--|-----|-------|-----|------------------|------------------|------------------------|
|  |     | min   | max | Factory American | Factory European |                        |
| <b>Menu</b>  |     |       |     |                  |                  |                        |
| <b>Enable PD PID</b><br>Enabled (1) / Disabled (0) | 770 | 0     | 1   | Disable          | Disable          | *                      |

\* This function can be set on a digital programmable input.

|                      |          |  |
|----------------------|----------|--|
| <b>Enable PD PID</b> | Enabled  | Enabling of the block proportional-derivative  |
|                      | Disabled | Disabling of the block proportional-derivative |

| PD control |                      |
|------------|----------------------|
| [768]      | PD P gain 1 PID [%]  |
| [766]      | PD D gain 1 PID [%]  |
| [788]      | PD P gain 2 PID [%]  |
| [789]      | PD D gain 2 PID [%]  |
| [790]      | PD P gain 3 PID [%]  |
| [791]      | PD D gain 3 PID [%]  |
| [767]      | PD D filter PID [ms] |
| [421]      | PD output PID        |

| Parameter description | No. | Value  |        |                  |                  | Standard Configuration |
|-----------------------|-----|--------|--------|------------------|------------------|------------------------|
|                       |     | min    | max    | Factory American | Factory European |                        |
| PD P gain 1 PID [%]   | 768 | 0.00   | 100.00 | 10.00            | 10.00            |                        |
| PD D gain 1 PID [%]   | 766 | 0.00   | 100.00 | 1.00             | 1.00             |                        |
| PD P gain 2 PID [%]   | 788 | 0.00   | 100.00 | 10.00            | 10.00            |                        |
| PD D gain 2 PID [%]   | 789 | 0.00   | 100.00 | 1.00             | 1.00             |                        |
| PD P gain 3 PID [%]   | 790 | 0.00   | 100.00 | 10.00            | 10.00            |                        |
| PD D gain 3 PID [%]   | 791 | 0.00   | 100.00 | 1.00             | 1.00             |                        |
| PD D filter PID [ms]  | 767 | 0      | 1000   | 0                | 0                |                        |
| PD output PID         | 421 | -10000 | +10000 | 0                | 0                |                        |

The gains of the block can remain fixed and programmed in this case through the parameters **PD P gain 1 PID** and **PD I gain 1 PID**, or changed depending on machine parameters, through the function **Adap spd reg**. In this case the gains come from **PD P gain 1-2-3 PID** and **PD I gain 1-2-3 PID**.

For example, it is possible to modify, dynamically, the gains of PD block according to the speed, to a regulation parameter internal to the drive, or to an analog input proportional to the unit related to the machine. The behaviour of the regulator can be so configured to meet the needs of the machine.

**Note:** When **Adap Spd reg** has been enabled (paragraph 6.13.2. of the manual), it operates both on the PID function and on the gains of the speed regulator. So it is necessary to appropriately program all relative parameters. If one wishes to modify only the gains of the speed regulator and keep fixed the gains of the PID function, it is necessary set the three proportional gains and integral gains of the PD block at the same value. The same is valid in case the PID gains have to be modified and the speed regulator gains must remain fixed.

- PD P gain 1** Proportional gain 1 of the block PD (its selection depends on the eventual enabling of the function **Adap Spd reg** and its configuration).
- PD D gain 1** Derivative gain 1 of block PD (its selection depends on the eventual enabling of the function **Adap Spd reg** and its configuration).
- PD P gain 2** Proportional gain 2 of the block PD (its selection depends on the eventual enabling of the function **Adap Spd reg** and its configuration).
- PD D gain 2** Derivative gain 2 of block PD (its selection depends on the eventual enabling of the function **Adap Spd reg** and its configuration).
- PD P gain 3** Proportional gain 3 of the block PD (its selection depends on the eventual enabling of the function **Adap Spd reg** and its configuration).
- PD D gain 3** Derivative gain 3 of block PD (its selection depends on the eventual enabling of the function **Adap Spd reg** and its configuration).
- PD D filter PID** Time constant of the filter from the derivative side.
- PD output PID** PD block output.

### 6.16.3.7 Output reference

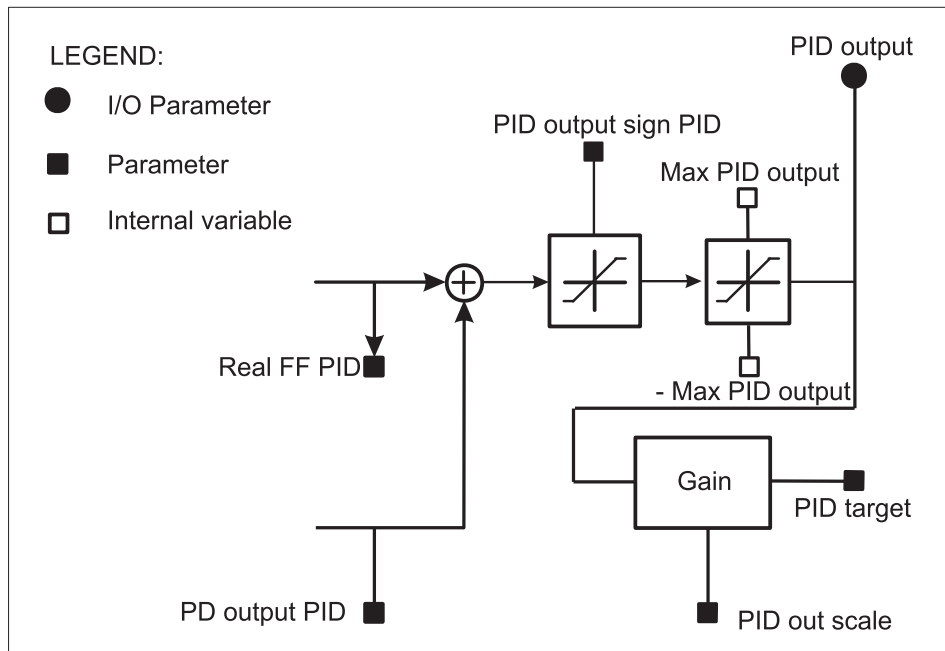

Figure 6.16.3.5: Output reference block description

| PD control |                  |
|------------|------------------|
| [772]      | PID out sign PID |
| [774]      | PID output       |

| Parameter description                                  | No. | Value  |        |                  |                  | Standard Configuration |
|--|-----|--------|--------|------------------|------------------|------------------------|
|  |     | min    | max    | Factory American | Factory European |                        |
| <b>PID out sign PID</b><br>Positive (0)<br>Bipolar (1) | 772 | 0      | 1      | 1                | 1                |                        |
| <b>PID output</b>                                      | 774 | -10000 | +10000 | 0                | 0                | *                      |

\* This parameter can be set on an analogue programmable output.

**PID out. sign PID** Through this parameter it is possible to set the output of the regulator to be either bipolar or simply positive (clamp of negative side).

**PID output** Display of regulator output. It is possible to program this parameter to an analog output, in order to perform a reference cascade in multidrive systems.

| PID target |               |
|------------|---------------|
| [782]      | PID target    |
| [773]      | PID out scale |

| Parameter description | No. | Value    |          |                  |                  | Standard Configuration |
|-----------------------|-----|----------|----------|------------------|------------------|------------------------|
|                       |     | min      | max      | Factory American | Factory European |                        |
| <b>PID target</b>     | 782 | 0        | 65535    | 0                | 0                |                        |
| <b>PID out scale</b>  | 773 | -100.000 | -100.000 | 1.000            | 1.000            |                        |

|                      |  |
|----------------------|--|
| <b>PID target</b>    | Address of the parameter which contains the value to be used as PID target. To obtain the real settable value, it is necessary to add +2000H (8192 decimal) to the parameter number. |
| <b>PID out scale</b> | Matching factor of <b>PID output</b> . Its value depends on the parameter to which the regulator output is addressed.  |

Through the parameter **PID target** it is possible to select which point of the drive will be addressed for output signal of the regulation. The selectable parameters are those assigned as writing parameters (W or R/W) indicated in the paragraph 10.4. “*List of high-priority parameters*”. The units are those indicated in the notes at the end of the paragraph.

Programming example of the speed reference 1 (parameter **Speed ref 1**) on **PID target**:

Menu OPTION

```

    _____> PID
           _____> PID target
                   _____> PID target = 8234

```

**PID target** must be set according to the number of the parameter to which it will be associated, choosing it from the paragraph 10.4. “*List of high-priority parameters*” (**Speed ref 1** has the decimal number 42). To obtain the value it must be added the decimal number 8192 (fixed offset):

$$8192 + 42 = 8234.$$

**Note:** When the ramp function has been enabled, Speed ref 1 will be automatically programmed on its output. To have it available it is necessary to set parameter Enable ramp = disable.

**Speed ref 1** will be set in RPM x 4, considering that **PID output** assumes values included between 0...10000, it is necessary to set appropriately the calibration through **PID out scale**.

Calculation of **PID out scale**:

If it is necessary that **PID output**, at its max. value = 10000, corresponds at speed reference = 2000rpm it is necessary to set:

$$\mathbf{PID\ out\ scale} = (2000 \times 4) / 10000 = 0.8$$

It is possible to read the set value of **Speed ref 1** in the appropriate parameter of the menu **INPUT VARIABLES / Speed ref**.

**Note:** The value of PID out scale will be defined according to the system which is being controlled. For a better understanding, please refer to the paragraph “*Application examples*”.

### 6.16.3.8 Function of calculation for Initial diameter

This function performs a preliminary calculation of the diameter of an unwinder/winder before starting the line. This allows better control of the system avoiding unwanted balancing of the dancer.

The calculation is based on the measure of the movement of the dancer from the position of lower fullrange to its central position of work, and on the measure of angular movement of the roll during the initial phase.

**Note:** The function of initial diameter calculation can be carried out only when the winder/unwinder are controlled through dancer (no load cell) and the speed feed-back is carried out through encoder.

The result of the calculation is assigned to the parameter **PI output PID**, and so it represents the multiplier factor of the feed-forward, in order to obtain the angular speed reference of the motor.

Its value is universally proportional to the roll diameter.

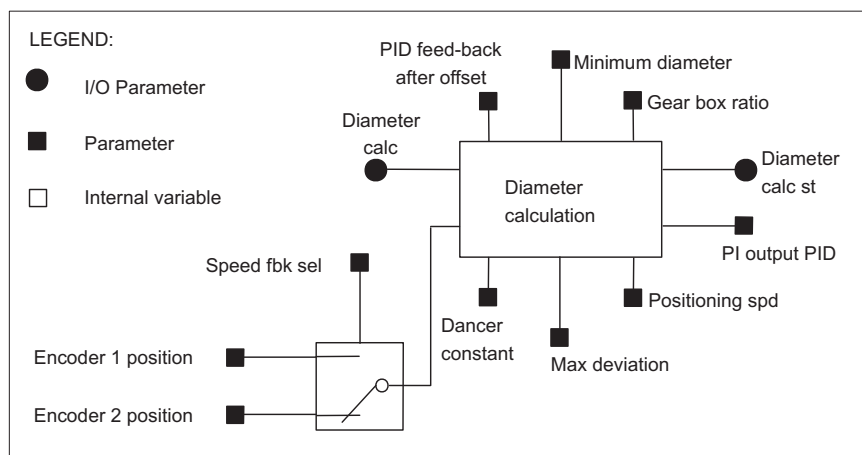

Figure 6.16.3.6: Diameter calculation block description

#### Diameter calc

|       |                       |
|-------|-----------------------|
| [794] | Diameter calc         |
| [795] | Positioning spd [rpm] |
| [796] | Max deviation         |
| [797] | Gear box ratio        |
| [798] | Dancer constant [mm]  |
| [799] | Minimum diameter [cm] |

| Parameter description                               | No. | Value |        |                  |                  | Standard Configuration |
|---|-----|-------|--------|------------------|------------------|------------------------|
|   |     | min   | max    | Factory American | Factory European |                        |
| <b>Diameter calc</b><br>Enabled (1)<br>Disabled (0) | 794 | 0     | 1      | 0                | 0                |                        |
| <b>Positioning spd [rpm]</b>                        | 795 | -100  | +100   | 0                | 0                |                        |
| <b>Max deviation</b>                                | 796 | 0     | +10000 | 8000             | 8000             |                        |
| <b>Gear box ratio</b>                               | 797 | 0.001 | 1.000  | 1.000            | 1.000            |                        |
| <b>Dancer constant [mm]</b>                         | 798 | 1     | 10000  | 1                | 1                |                        |
| <b>Minimum diameter [cm]</b>                        | 799 | 1     | 2000   | 1                | 1                |                        |

\* This function can be set on a digital programmable input.

- Diameter calc**      Enabling of the initial function of diameter calculation.  
The calculation will be enabled by setting **Diameter calc** = Enable.  
If **Diameter calc** has been programmed on a digital input, this must be brought to a high logic level.
- Positioning spd**      Motor speed at which the dancer is at its central working position, during the calculation phase of the initial diameter.
- Max deviation**      Value expressed in count of D/A which corresponds to the maximum shift allowed by the dancer. This value will be associated with the starting measurement of the dancer movement during the calculation of the initial diameter.
- During the preliminary phase of the commissioning, it is necessary to carry out the self-calibration of the analog inputs, so at the fullrange position of the dancer they will correspond, whatever was the value of the analog input, at 10000 counts. The parameter **Max deviation**, in order to guarantee a precise calculation of the movement, must be set at a value slightly lower. (standard **Max deviation** = 8000).
- Gear box ratio**      Ratio reduction between the motor and the roll ( $\leq 1$ ).
- Dancer constant**      It expresses the measure in mm, the total bunching of material in the dancer.

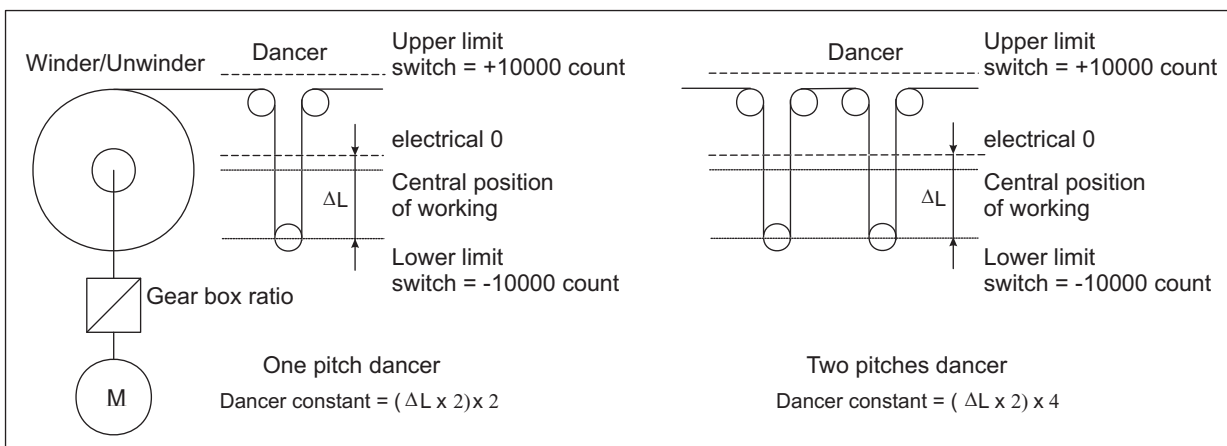

Figure 6.16.3.7: Diameter calculation

**Measurement of Dancer constant:**

With dancer in lower fullrange position, perform the self-calibration of the analog input programmed as **PID feed-back**.

Set the keypad of the drive on the parameter **PID feed-back**.

Measure and multiply by 2, the distance in mm between the lower mechanical fullrange and the position of the dancer that, on the parameter **PID feed-back**, will display 0 (position of electrical 0).

Multiply the above calculated value by 2 if the dancer has only one pitch, by 4 if the dancer has two pitches and so on, as per the figure above.

**Minimum diameter**      Min. value of core diameter expressed in cm.



### 6.16.3.9 Procedure of calculation for initial diameter

The calculation is based on the measurement of the dancer movement from the lower fullrange position to its central working position, and on the measurement of the angular movement of the coil during the drawing phase. For that reason, during this period, make sure that the gear maintaining the material blocked. For this reason it is necessary to enable the regulation of the nip-roll drive with speed reference = 0.

If line nip-rolls are controlled by dancers or load cells, it is necessary to carry out the diameter calculation of the winders/unwinders first, then the gear.

The parameter **PI central v sel** must be set at 0 to avoid **PI output PID** being set automatically at a predefined value.

Bringing the digital input programmed as **Diameter calc** to a high logic level (+24V) , if the drive is enabled, will start the procedures. During this phase, the parameters **Enable PI PID** and **Enable PD PID** are automatically disabled.

The regulation verifies the signal coming from the dancer potentiometer. If this is higher than what is already set in **Max deviation**, the motor begins following the speed reference set in **Positioning speed** in order to wind the material and bring the dancer to its central position of working.

The polarity of the reference assigned to **Positioning speed** will be winder / unwinder equal to the one working as a winder.

If the initial regulation verifies that the signal coming from the potentiometer of the dancer is lower than what already set in **Max deviation**, the motor starts running with speed reference set in **Positioning speed** in order to unwind the material and bring the dancer on the point identified by **Max deviation**, at this point the reference will be inverted to bring the dancer to its central position.

When the dancer has reached the central position, the parameter **PI output PID** will be set at a value inversely proportional to the diameter and the digital output **Diameter calc st**, that indicates the end of diameter calculation, will be brought to high logical level .

At this point, if **Enable PI PID** and/or **Enable PD PID** are enabled, the system passes automatically in regulation. For this reason generally the digital inputs programmed as **Diameter calc** and **Enable PI PID** and/or **Enable PD PID** will be brought to high logic level at the same time.

The output signal Diameter calc st can be used to reset the command **Diameter calc** (this command will be activated on the rising edge of the digital input). For that reason, it must be brought to high logical level after the supply of the regulation part of the drive and reset once the initial calculation phase has finished.

The value of **PI output PID** will be calculated with the following formula:

$$\text{PI output PID} = (\text{Min diameter} \times \text{PI top lim}) / \text{Value of the calculated diameter}$$

The parameters **PI top limit** and **PI bottom limit** in the menu **PI controls** have to be set according to the max. and min. diameter of the roll. For better explanation, please refer to paragraph 6.16.3.10 “Application examples”.

### 6.16.3.10 Examples of application

#### Nip-roll control with dancer

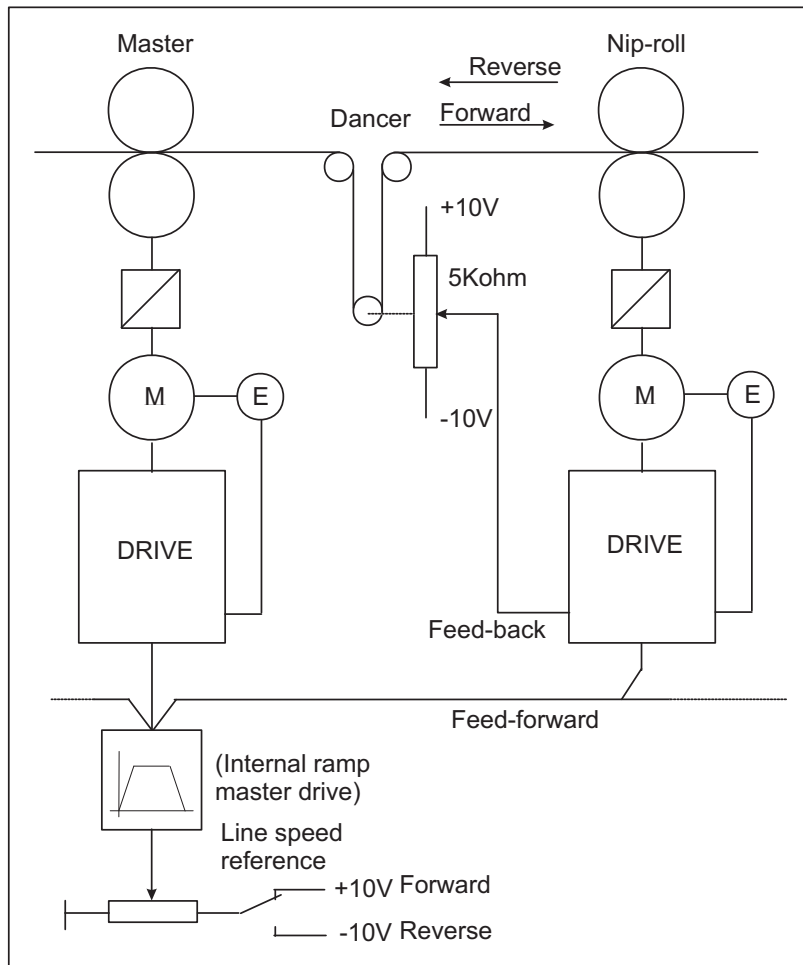

Figure 6.16.3.8: Nip-roll control with dancer

#### Machine data:

Rated speed of slave motor  $V_n = 3000\text{rpm}$

Slave motors speed correspondent to the max. line speed =  $85\% V_n = 2550\text{rpm}$

Max. correction of the dancer =  $\pm 15\%$  of the line speed =  $\pm 382.5\text{rpm}$

The slave drive must be sent the analog signals regarding line speed and the position of the dancer (whose potentiometer will be supplied between terminals -10V... +10V) and the digital commands regarding the enabling of the PID control.

The regulator output will be sent to speed reference 1.

Drive setting: (below parameters regarding only the PID function)

## **Input/output**

Set **Analog input 1** as input for the wiper of the dancer potentiometer.

**Analog input 1 / Select input 1 = PID Feed-back**

Set **Analog input 2** as line speed input (feed- forward).

To set the feed-forward on analog input, seeing that this one is not directly accessible in the list of high-priority parameters, it is necessary to pass through a supporting parameter **PAD 0.....PAD 15**.

**Analog input 2 / Select input 2 = PAD 0**

Set **Digital input 1** as enabling input of PI block of the PID

**Digital input 1 = Enable PI PID**

Set **Digital input 2** as enabling input of PD block of the PID

**Digital input 2 = Enable PD PID**

## **Parameters**

Set **Speed base value** equal to the rated speed of the motor.

**Speed base value** = 3000rpm

Set **PID source** as **PAD 0**.

(**PAD 0** has been used as supporting parameter for the feed-forward reading on **Analog input 2**)

For PID source, set the parameter number to which it will be associated, choosing it from the list of paragraph 10.4. “*List of high-priority parameters*” (**PAD 0** has the decimal number 503).

To obtain the correct value it must be added to the decimal number 8192 (fixed offset):

**PID source** =  $(8192 + 503) = 8695$

Set **PID source Gain** so that **Feed-fwd PID** reaches, along with the max. analog value on Analog input 2, 85% of its max. value =  $10000 \times 85\%$ .

When an analog input is set on a PAD parameter, this will have a max. value +/- 2047.

So:

**PID source Gain** =  $(\max \text{Feed-fwd PID} \times 85\%) / \max \text{PAD 0} = (10000 \times 0.85) / 2047 = 4.153$

Set **PID target** as **Speed ref 1**.

**Note:** When the ramp function is enabled, **Speed ref 1** is not available. In order to keep it available, it is necessary to set the parameter **Enable ramp** = Disable.

**PID target** must be set to the parameter number to which it will be associated, choosing it from the list of paragraph 10.4, “*List of high-priority parameters*” (**Speed ref 1** has the decimal number 42).

To obtain the correct value it must be added the decimal number 8192 (fixed offset)

**PID target** =  $8192 + 42 = 8234$

Set **PID out scale** so that , the max. analog value on **Analog input 2 (Feed-fwd PID = 8500)** and **Enable PI PID** and **Enable PD PID = Disable**, **Speed ref 1** is the same at 2550rpm.

The parameter **Speed ref 1** will set in RPM x 4, so:

$$\text{PID out scale} = (2550 \times 4) / 8500 = 1.2$$

Set **PI central v sel** = 1.

Set **PI central v 1** = 1

In absence of a correction performed by the PI block of the regulator, the line speed reference (Feed-forward) must be multiplied by 1 and sent directly to the speed regulator of the drive.

In this application, the regulator carries out a mono type proportional control. The correction will be indicated in percentage, according to the line speed, from 0 to the maximum.

Set **PI top limit** and **PI bottom limit** so that, with max. of the dancer (max.value of the analog input 1 = **PID Feed-back**) and setting the proportional gain of the PI block at 15%, it will correspond to an equal proportional correction of feed-forward. For this reason set:

**PI top limit** = 10

**PI bottom limit** = 0.1

Set **PI P gain PID** = 15%

Set **PI I gain PID** = 0%

With this configuration, having a correction proportional to the line speed, the PI block is not able to position the dancer at speed = 0. In order to do the drawing in stop conditions, it is necessary to use the PD block.

Set **PD P gain PID** to a value that allows positioning of the dancer without large dynamic variations.

For example:

**PD P gain PID** = 1%

If necessary, use the derivative component as damping component of the system, setting for example:

**PD D gain PID** = 5%

**PD D filter PID** = 20ms

If not necessary, keep these parameters = 0.

If it is necessary to carry out a reference cascade for another drive, set **PID output** on an analog output, for example:

**Analog output 1 / Select output 1= PID output**

(with **Real FF PID** = 10000 count, **Analog output 1** = 10V).

## Nip-rolls control with load cell

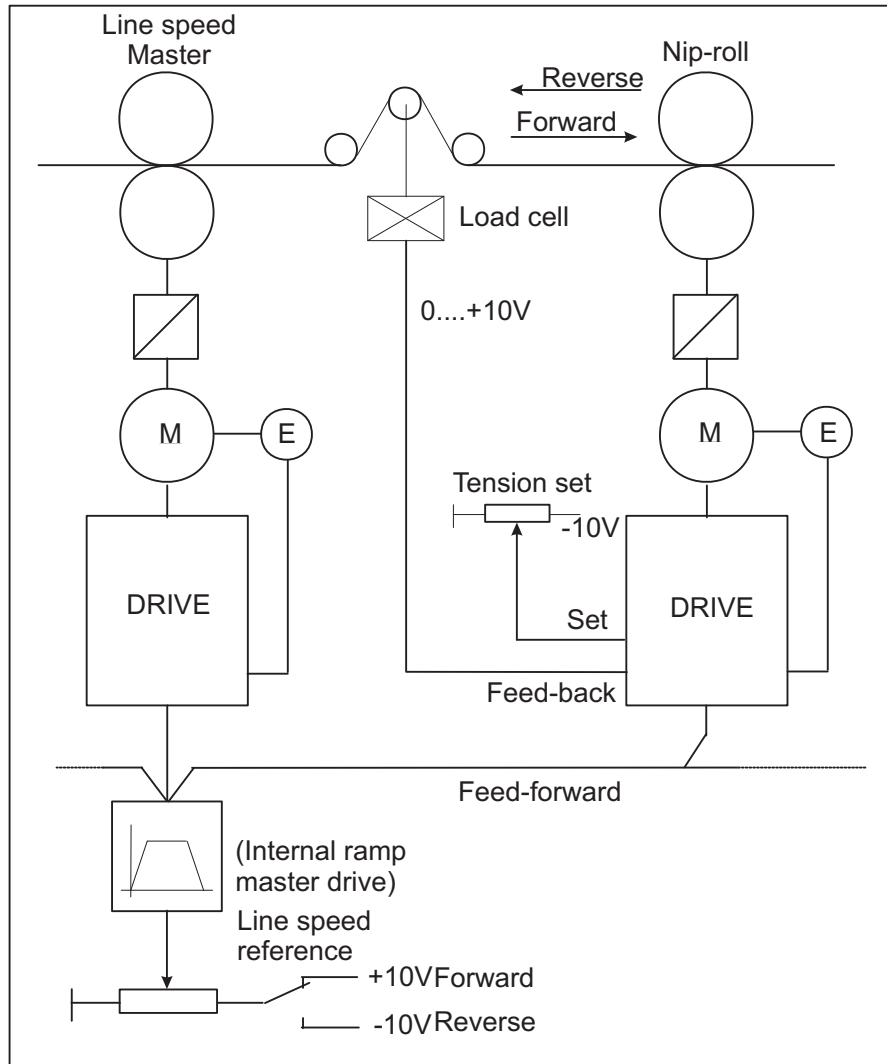

Figure 6.16.3.9: Nip-rolls control with load cell

### Machine data:

Rated speed of slave motor  $V_n = 3000\text{rpm}$

Slave motors speed corresponding to the max. line speed =  $85\% V_n = 2550\text{rpm}$

Max. correction of the dancer =  $\pm 20\%$  of the line speed =  $\pm 510\text{rpm}$

To the slave drive must be sent the analog signals regarding the line speed and the position of the load cell signal ( $0... +10\text{V}$ ) and the tension set ( $0... +10\text{V}$ ), and the digital commands regarding the enabling of the PID control.

The regulator output will be sent to the speed reference 1.

Drive setting: (below are parameters regarding only the PID function)

## ***Input/output***

Set **Analog input 1** as input for the load cell signal.

**Analog input 1 / Select input 1= PID Feed-back**

Set **Analog input 2** as line speed input (feed- forward).

Setting the feed-forward on analog input, seeing it is not directly inserted in the list of high-priority parameters, it is necessary to pass through a supporting parameter **PAD 0.....PAD 15**.

**Analog input 2 / Select input 2 = PAD 0**

Set **Analog input 3** as input for the tension set (**PID offset 0**).

**Analog input 3 / Select input 3 / PID offset 0**

Set **Digital input 1** as enabling input of the PI block of the PID

**Digital input 1 = Enable PI PID**

Set **Digital input 2** as enabling input of the PD block of the PID

**Digital input 2 = Enable PD PID**

## ***Parameters***

Program **Speed base value** equal to the rated speed of the motor.

**Speed base value** = 3000rpm

Program **PID source** as **PAD 0**.

(**PAD 0** has been used as supporting parameter of the feed-forward reading on **Analog input 2**)

For **PID source** set the parameter number to which it will be associated, choosing it from the list of paragraph 10.4. "*List of high-priority parameters*" (**PAD 0** has the decimal number 503).

To obtain the correct value it must be added the decimal number 8192 (fixed offset):

**PID source** = (8192 + 503) = 8695

Set **PID source Gain** so that **Feed-fwd PID** reaches, along with the max. analog value on **Analog input 2**, 85% of its max. value = 10000 x 85%.

When an analog input is set on a PAD parameter , this will have a max. value +/- 2047.

So:

**PID source Gain** = (max **Feed-fwd PID** x 85%) / max **PAD 0** = (10000 x 0.85) / 2047 = 4.153

Set **PID target** as **Speed ref 1**.

**Note:** When the ramp function is enabled, **Speed ref 1** is not available. In order to have it available, it is necessary to set the parameter **Enable ramp** = Disable.

For **PID target** set the parameter number to which it will be associated, choosing it from the list of paragraph 10.4 "*List of high-priority parameters*" (**Speed ref 1** has the decimal number 42).

To obtain the correct value it must be added the decimal number 8192 (fixed offset)

**PID target** = 8192 + 42 = 8234

Set **PID out scale** so that, along with the max. analog value on **Analog input 2 (Feed-fwd PID = 8500)** and with **Enable PI PID** e **Enable PD PID** = disable, **Speed ref 1** is the same at 2550rpm.

**Speed ref 1** will be set in *RPM* x 4, so:

$$\text{PID out scale} = (2550 \times 4) / 8500 = 1.2$$

Set **PI central v sel** = 1.

Set **PI central v 1** = 1

In the absence of a correction carried out from the PI block of the regulator, the line speed reference (Feed-forward) must be multiplied by 1 and sent directly to the speed regulator of the drive.

This application operates by using proportional control. The correction will be indicated in percentage according to the line speed, from 0 to the maximum.

Program **PI top limit** and **PI bottom limit** so that the max. correction of PI block corresponds at 20% of line speed.

**PI top limit** and **PI bottom limit** parameters are the maximum and minimum multiplier factor of Feed forward value.

At the max. line speed it will correspond 2550rpm of the motor (max. feed-forward).

$$\text{Max. correction} = 2550 \times 20\% = 510\text{rpm}$$

$$2550 + 510 = 3060\text{rpm} \longrightarrow \text{PI top limit} = 3060 / 2550 = 1.2$$

$$2550 - 510 = 2040\text{rpm} \longrightarrow \text{PI bottom limit} = 2040 / 2550 = 0.80$$

which will to multiply the setting of **PI central v 1** (= 1) by + 20% (1.2) and - 20% (0.80).

With this configuration, having a correction proportional to the line speed, the PI block is not able to apply tension at speed = 0. In order to apply tension in stop conditions, it is necessary to use on the PD block.

The gains of the single components have to be set with loaded machine; it is possible to start tests with values below indicated (default values):

Set **PI P gain PID** = 10%

Set **PI I gain PID** = 10%

Set **PD P gain PID** = 10%

In case use the derivative component for forcing the regulator output during velocity changes of the system, programming for example:

**PD D gain PID** = 5%

**PD D filter PID** = 20ms

If not necessary, keep these parameters = 0.

In case it is necessary to carry out a references cascade for another drive, set **PID output** on an analog output, for example:

**Analog output 1 / Select output 1= PID output**

(with **Real FF PID** = 10000 count, **Analog output 1** = 10V).

**Note:** If it is necessary, a system with the integral regulation enabled, with feed-forward = 0, and the need to apply tension of the system with null error also when the machine is stopped, please refer to the paragraph "Generic PID".

## Winder/Unwinder control with dancer

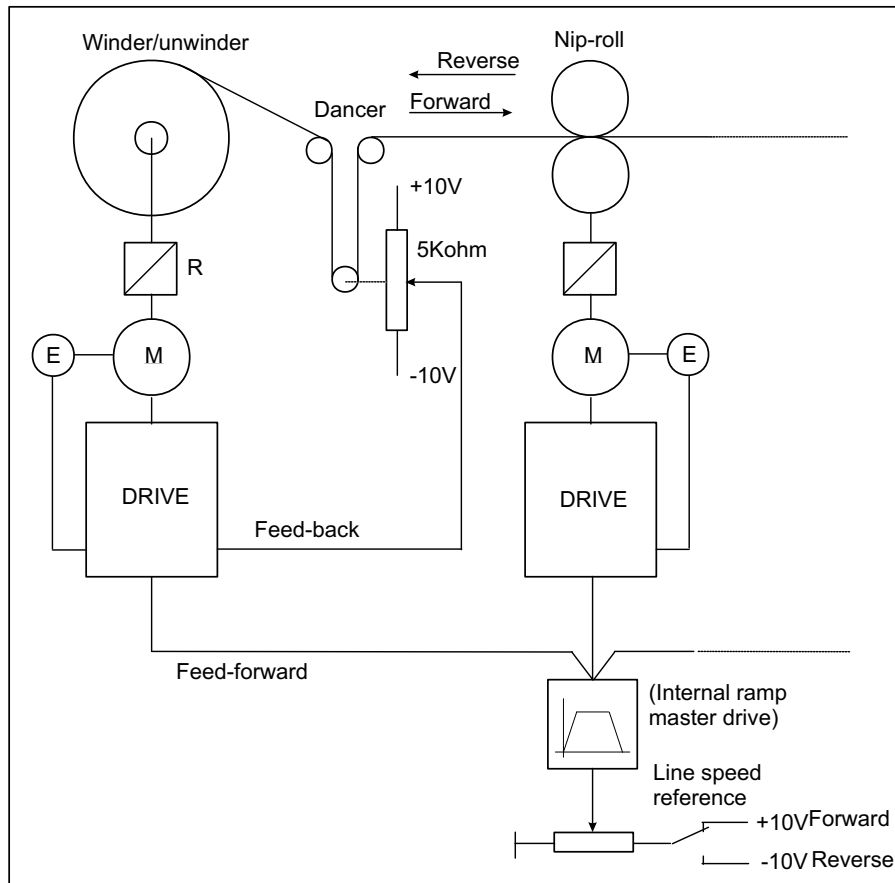

Figure 6.16.3.10: Winder/Unwinder control with dancer

### Machine data:

Max. line speed = 400m/min

Rated speed of the motor winder/unwinder  $V_n = 3000\text{rpm}$

Max. diameter of the winder/unwinder = 700mm

Min. diameter of the winder/unwinder = 100mm

Reduction ratio motor-coil = 0.5

One pitch dancer

Dancer stroke from the lower limit switch to the position of electric 0 = 160mm

The drive of the winder/unwinder must be sent the analog signals regarding line speed and the position of the dancer (whose potentiometer will be supplied between the terminals -10V... +10V) and the digital commands regarding the enabling of the PID control.

The regulator output will be sent to the speed reference 1.

Drive setting: (below are only the parameters regarding the PID function)

### Input/output

Set **Analog input 1** as input for the wiper of the dancer.

**Analog input 1 / Select input 1 = PID Feed-back**

Set **Analog input 2** as line speed input (feed- forward).

To set the feed-forward on an analog input, seeing that this one is not directly accessible in the list of high-priority parameters, it is necessary to pass through a supporting parameter **PAD 0.....PAD 15**.



## Analog input 2 / Select input 2 = PAD 0

Set **Digital input 1** as enabling input of the PI block of the PID

**Digital input 1 = Enable PI PID**

Set **Digital input 2** as enabling input of the PI block of the PID

**Digital input 2 = Enable PD PID**

Set **Digital input 3** as enabling input of the calculation function of initial diameter.

**Digital input 3 = Diameter calc**

Set **Digital output 1** as signalling “ phase of calculation of starting diameter “.

**Digital output 1 = Diameter calc st**

## Parameters

Set **Speed base value** equal to the rated speed of the motor.

**Speed base value = 3000rpm**

Set **PID source** as **PAD 0**.

(**PAD 0** has been used as supporting parameter of the feed-forward reading on **Analog input 2**)

For **PID source**, set the parameter number to which it will be associated, choosing it from the list of the paragraph 10.4. “*List of high-priority parameters*” (**PAD 0** had the decimal number 503). To obtain the correct value it must be added the decimal number 8192 (fixed offset):

**PID source = (8192 + 503) = 8695**

Set **Gain source** and **PID out scale** so that, the max. analog value on **Analog input 2** and without the PID correction (**Enable PI PID e Enable PD PID = Disable**), the peripheral speed of the roll in conditions of minimum diameter (core) is the same of the max. line speed.

Calculation of the motor speed in the condition above mentioned:

$$V_p = \pi \times \Phi_{\min} \times \omega \times R$$

where:

$V_p$  = peripheral speed of the coil = line speed

$\Phi_{\min}$  = min. diameter of the coil [m]

$\omega$  = angular speed of the motor [rpm]

R = reduction ratio motor-coil

$$\omega = V_p / \pi \times \Phi_{\min} \times R = 400 / (\pi \times 0.1 \times 0.5) = 2546\text{rpm} = \text{about } 2550\text{rpm}$$

Maintaining a 15% margin as to the saturation limit of the regulator (10000 count), it is necessary to set **PID source Gain** so that **Feed-fwd PID** reaches, along with the max. analog value on **Analog input 2**, 85% of its max. value.

When an analog input is set on a PAD parameter, this will have a max. value +/- 2047.

So:

$$\text{PID source Gain} = (\text{max Feed-fwd PID} \times 85\%) / \text{max PAD 0} = (10000 \times 0.85) / 2047 = 4.153$$

The speed reference of the motor is set in  $RPM \times 4$ , so program as follows:

$$\text{PID out scale} = (2550 \times 4) / (10000 \times 0.85) = 1.2$$

Set **PID target** as 1 **Speed ref 1**.

**Note:** When the ramp function has been enabled, **Speed ref 1** is not available. To keep it available it is necessary to set the parameter **Enable ramp** = Disable.

For **PID target** set the parameter number to which it will be associated, choosing it from the list of paragraph 10.4. "*List of high-priority parameters*" (**Speed ref 1** has the decimal number 42).

To obtain the correct value it must be added the decimal number 8192 (fixed offset):

$$\text{PID source} = (8192 + 42) = 8234$$

Set **PI central v sel** = 0.

With this configuration, having a correction proportional to the line speed, the PI block is not able to position the dancer at speed = 0. In order to do the drawing in stop conditions, it is necessary to use the PD block.

As previously stated, the procedure determines the theoretical multiplier factor (**PI output PID**) of feed-forward as relation of the diameter calculated. In order to send to the drive the correct speed angular value.

**Note:** When **PI central v sel** = 0 has been selected and the the PI block has been disabled, the system keeps in memory, or reset automatically in case of switching off, the last value calculated for **PI output PID**. If it would be necessary to set the value in order to have at the output an incorrect reference and so equal to the feed-forward, it is possible to configure a digital input as correction reset.

So configure:

**Digital input 4 = PI central v S0**

**PI central v 1** = 1.00

Bringing the digital input to logical high level, the **PI output PID** will be reset.

Set **PI top lim** and **PI bottom lim** according to the ratio diameters coil.

Parameters **PI top lim** and **PI bottom lim** can be considered as multiplier factors, respectively max. and min. of the feed-forward.

Considering that the angular speed of the motor and the corresponding reference, change inversely to the unwinder/winder diameter;

$$\text{Set: } \text{PI top lim} = 1 \quad \text{PI bottom lim} = \Phi_{\min} / \Phi_{\max} = 100 / 700 = 0.14$$

Below is an explanation of above settings.

Calculation of the angular speed of the motor:

$$\omega_{\max} = V_l / (\pi \times \Phi_{\min} \times R) \quad \text{and} \quad \omega_{\min} = V_l / (\pi \times \Phi_{\max} \times R)$$

where:

$\omega_{\max}$  = angular speed of the motor in conditions of min. diameter [rpm]

$\omega_{\min}$  = angular speed of the motor in conditions of max. diameter [rpm]

$V_l$  = line speed

$\Phi_{\min}$  = min. diameter of the core[m]

$\Phi_{\max}$  = max. diameter of the core[m]

R = gear reduction ratio motor-winder/unwinder

So:  $\omega_{\max} / \omega_{\min} = \Phi_{\max} / \Phi_{\min}$

from which

$$\omega_{\min} = (\Phi_{\min} / \Phi_{\max}) \times \omega_{\max}$$

Considering that the parameters **PI top lim** and **PI bottom lim** can be seen as multiplier factors of min. and max. of the feed-forward.

Multiplying the feed-forward by **PI top lim** = 1, gives the max. speed reference concerning the minimum diameter.

Multiplying the feed-forward by **PI bottom lim** = 0.14, gives the min. speed reference concerning the max. diameter.

This application operates by using the proportional-integral regulation.

The gains of a single component will be experimentally set with a loaded machine. It is possible to begin the tests with the values below:

Set **PI P gain PID** = 15%

Set **PI I gain PID** = 8%

Set **PD P gain PID** = 5%

In this case, use the derivative component for forcing the regulator output during velocity changes of the system. Programming for example:

**PD D gain PID** = 20%

**PD D filter PID** = 20ms

In case it is necessary to carry out a reference cascade for another drive, program **PID output** on an analog output, for example:

**Analog output 1 / Select output 1= PID output**

(with **Real FF PID** = 10000 count, **Analog output 1** = 10V).

### ***Parameters regarding the calculation function of the initial diameter***

This function is always necessary when one has to control an unwinder or when the starting diameter is unknown.

Set **Positioning spd** at the value in rpm with which the initial positioning of the dancer has to be done. For example:

**Positioning spd** = 15rpm

The polarity of the reference assigned to **Positioning speed** will be anyway (winder/unwinder) equal to the one functioning as a winder.

If for example one has to control an unwinder and the speed reference in standard functioning is positive, assign to **Positioning spd** a negative value.

Set **Max deviation** at a value slightly lower than the one correspondent to the position of max. mechanical travel allowed by the dancer.

During commissioning, it is always necessary to carry out the self calibration of the analog inputs of the drive. In particular the one regarding analog input 1, with dancer in its position of lower fullrange, This position is automatically assigned to the value 10000. So in order to guarantee a precise calculation it might be assigned:

**Max deviation** = 8000 (Default value)

Set **Gear box ratio** equal to the reduction ratio between the motor and the winder/unwinder:

**Gear box ratio** = 0.5

Set **Dancer constant** to the value in mm correspondent to the total accumulation of material in the dancer:

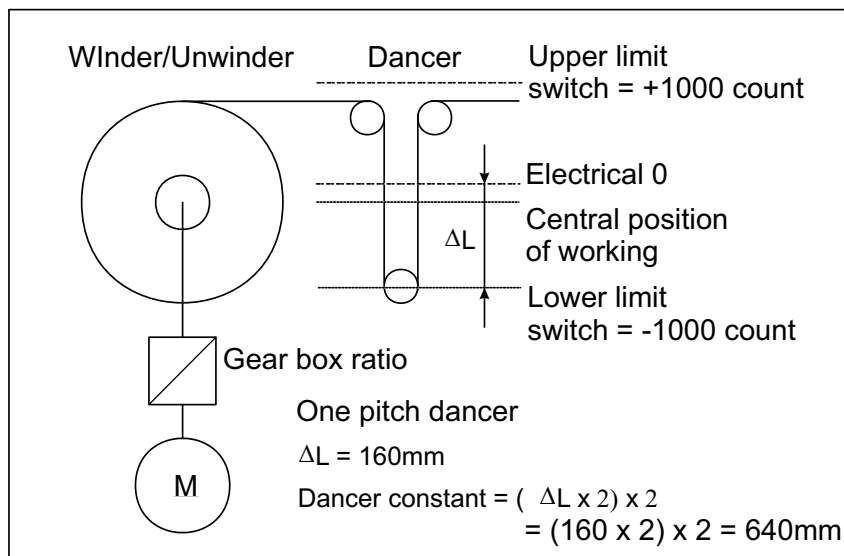

Figure 6.16.3.11: Diameter calculation

Measure of **Dancer constant**:

Set the keypad of the drive on the parameter **PID feed-back**.

Measure and multiply by 2, the distance between the lower mechanical fullrange and the position of the dancer so that in the parameter **PID feed-back** will display 0 (position of 0 electric).

As the dancer has only one pitch, multiply the above calculated value by 2.

In this case set:

**Dancer constant** = 640mm

Programm **Minimum diameter** equal to the minimum value of the core diameter [cm]:

**Minimum diameter** = 10cm

## Use of the diameter sensor

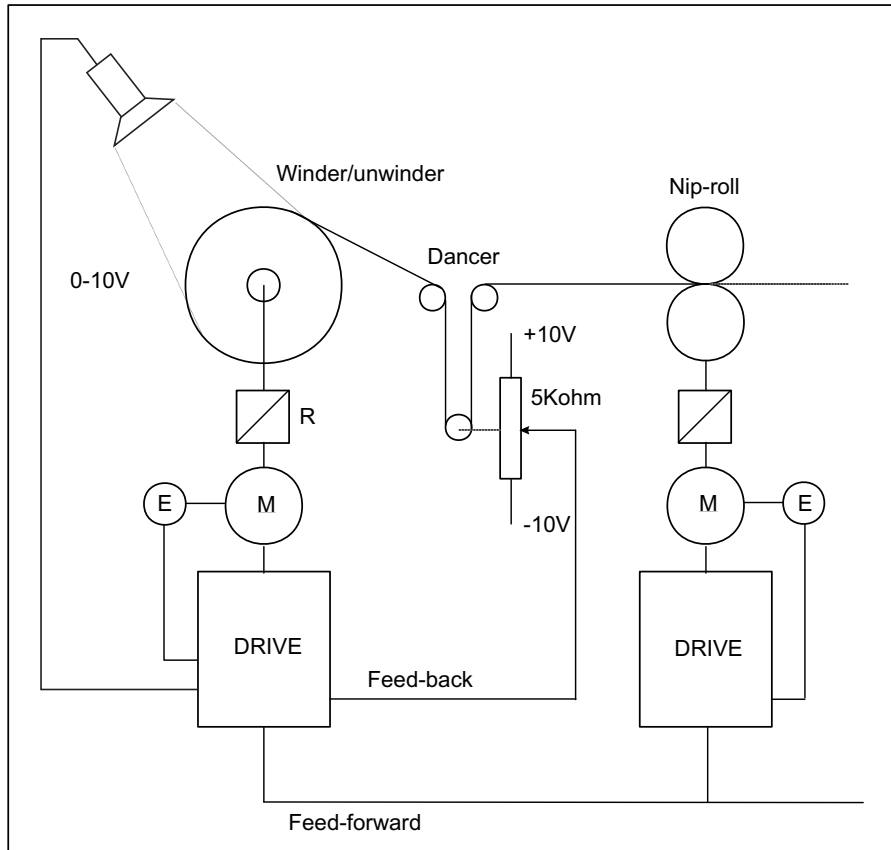

Figure 6.16.3.12: Winder/unwinder control with sensor diameter

The diameter sensor can be used in case of unwinder system with automatic gear.

In these cases, it is necessary to know the value of the starting diameter, in order to calculate the reference of the angular speed of the motor, before the insertion of the new core.

The transducer must set in order to supply a voltage signal proportional to the roll diameter.

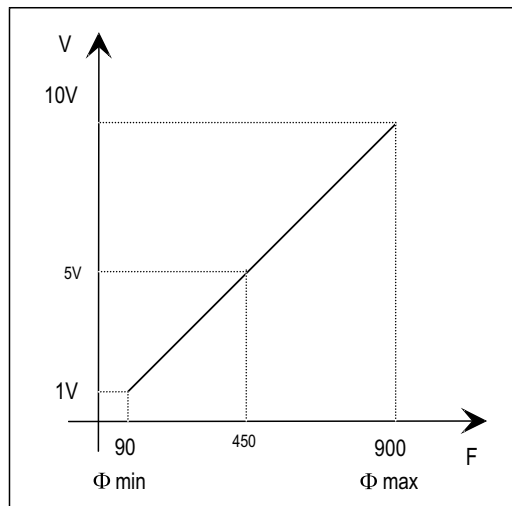

Figure 6.16.3.13: Relation between transducer signal and coil signal

Example:

|               |          |                         |
|---------------|----------|-------------------------|
| $\Phi_{\min}$ | = 90 mm  | transducer output = 1V  |
| $\Phi_{\max}$ | = 900 mm | transducer output = 10V |
| $\Phi$        | = 450 mm | transducer output = 5V  |

The analog input to which the sensor is connected, must be programmed as **PI central V3**.

The parameter **PI central v sel**, must be set = 3.

When **Enable PI PID** = disable, the value of **PI central V3** is written in **PI output PID** and used as multiplier factor of the feed-forward.

As previously described in the instruction book, the setting of PI output PID depends on the diameters ratio, so the voltage signal proportional to the diameter will be automatically recalculated with the formula:

$$\mathbf{PI\ central\ V3} = (\Phi_0 / \Phi_1)$$

Where:  $\Phi_0$  = minimum winder diameter

$\Phi_1$  = actual diameter

Setting resolution = 3 digits after the comma ( also if in **PI central V3** are displayed only 2 digits after the comma).

**Note !**

During commissioning, it is necessary to verify that the signal coming from the sensor as proportional to the diameter and that its maximum value is corresponding to 10V (carry out the autotune of the analog input).

It is necessary to verify that **PI top lim** and **PI bottom lim** had been programmed

## Pressure control for pumps and extruders

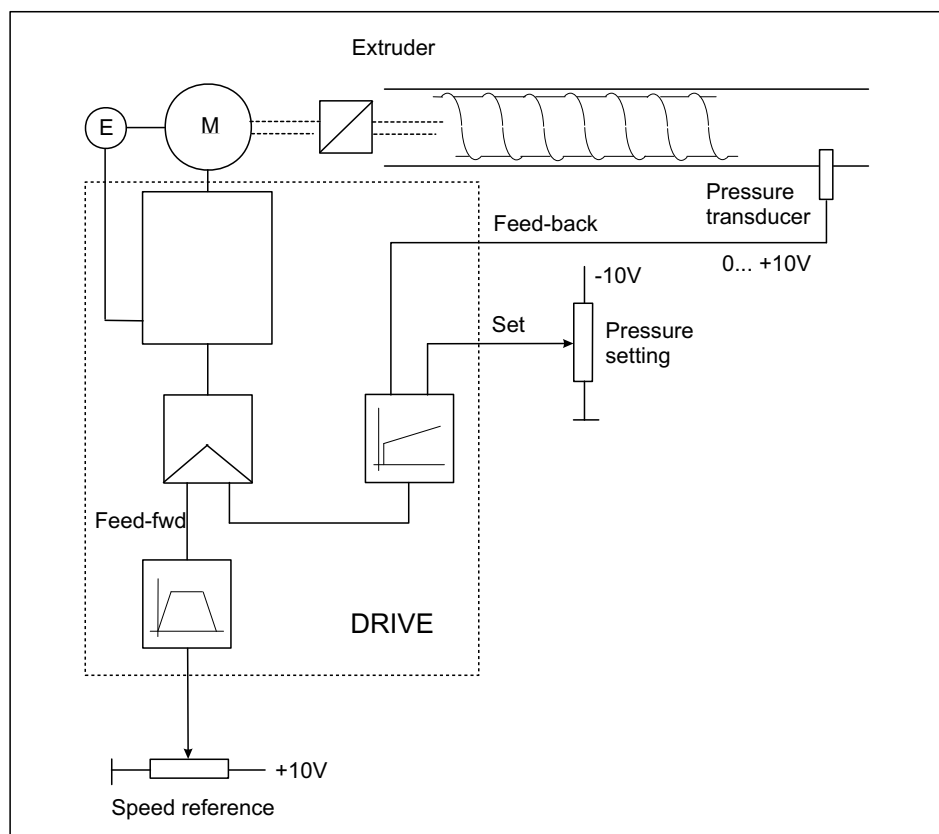

Figure 6.16.3.14: Pressure control for pumps and extruder

### Machine Data:

Nominal speed of the extruder motor  $V_n = 3000\text{rpm}$

Pressure transducer  $0... +10\text{V}$

The extruder slave drive must be sent analog signals concerning speed reference, the pressure transducer, the setting of potentiometer for pressure (supplied between  $0\text{V}... -10\text{V}$ ) and the digital commands concerning the enabling of the PID control.

The regulator output must be sent to the speed reference 1.

Setting of the drive: (below are only the parameters regarding the PID function)

### Input/output

Set **Analog input 1** as input for the pressure transducer.

**Analog input 1 / Select input 1 = PID Feed-back**

Set **Analog input 2** as input for the ramp block. The output of the ramp block must be used as speed reference. (feed- forward).

**Analog input 2 / Select input 2 = Ramp ref 1**

Set **Analog input 3** as input for the pressure setting (**PID offset 0**).

**Analog input 3 / Select input 3 / PID offset 0**

Set **Digital input 1** as enabling input for the PI block of the PID

**Digital input 1 = Enable PI PID**

Set **Digital input 2** as enabling input for the PD block of the PID

**Digital input 2 = Enable PD PID**

## Parameters

Set **Speed base value** equal to the motor nominal speed .

**Speed base value** = 3000rpm

Set **PID source** as **Ramp output**.

For **PID source** set the parameter number to which it will be associated, choosing it from the list of section 10.4. “*List of high priority parameters*” (**Ramp output** has the decimal number 113).

To obtain the correct value it must be added the decimal value 8192 (fixed offset):

**PID source** = (8192 + 113) = 8305

Set **PID source Gain** so that **Feed-fwd PID**, along with the maximum value of **Ramp output** (corresponding to the maximum value of the analog input 2), reaches 100% of its value = 10000.

The ramp reference and its output automatically acquire their maximum value from the setting of **Speed base value**. Therefore it must be taken into consideration that each writing or reading of any parameter concerning the speed is defined as  $RPM \times 4$ .

So: **PID source Gain** = max **Feed-fwd PID** / (**Speed base value** x 4) = 10000 / (3000 x 4) = 0.833

Set **PID target** as **Speed ref 1**.

**Note:** When the ramp function is enabled, **Speed ref 1** is not available. In order to make it available it is necessary to set the parameter **Enable ramp** = Disable. (This setting allows the working of the ramp block, but disconnects its output from the speed reference 1).

For **PID target**, set the parameter number to which it will be associated, choosing it from the list of the section 10.4. “*List of high priority parameters*” (**Speed ref 1** has the decimal number 42). To obtain the correct value it must be added the decimal value 8192 (fixed offset):

**PID target** = 8192 + 42 = 8234

Set **PID out scale** so that the maximum analog value on **Analog input 2** (**Feed-fwd PID** = 10000) and with **Enable PI PID** and **Enable PD PID** = Disable, **Speed ref 1** were equal to 3000rpm.

The **Speed ref 1** must be set as  $RPM \times 4$ , then:

**PID out scale** = (3000 x 4) / 10000 = 1.2

Set **PI central v sel** = 1.

Set **PI central v 1** = 1

In absence of correction performed by the PI block of the regulator, the line reference speed (Feed-forward) must be multiplied x 1 and sent directly to the speed regulator of the drive.

In this application, the regulator makes a proportional-integral control.

Set **PI top limit** and **PI bottom limit** in order to obtain maximum correction of the PI block equal to the 100% of the speed reference.

The parameters, **PI top limit** and **PI bottom limit** could be considered as the multiplier factor respectively maximum and minimum of the feed-forward.

**PI top limit** = 1

**PI bottom limit** = 0



In this application the regulator uses a proportional-integral type of control.

The gains of the various components must be set with the load on the machine. A reference, it is possible to start the test with the values below (default values):

Set **PI P gain PID** = 10%

Set **PI I gain PID** = 20%

Set **PD P gain PID** = 10%

If necessary, use the derivative component for forcing the regulator output during velocity changes of the system, setting for example:

**PD D gain PID** = 5%

**PD D filter PID** = 20ms

If not necessary, keep these parameters = 0.

### 6.16.3.11 Generic PID

Drive settings: (here below are reported only the ones concerning the PID function)

#### **Input/output**

Set **Analog input 1** as input of the variable which has to be regulated (Feed-back).

**Analog input 1 / Select input 1= PID Feed-back**

Set **Analog input 2** as input of the offset signal (**PID offset 0**).

**Analog input 2 / Select input 2 / PID offset 0**

Set **Digital input 1** as input for the enabling of the PI block of the PID

**Digital input 1 = Enable PI PID**

Set **Digital input 2** as input for the enabling of the PD block of the PID

**Digital input 2 = Enable PD PID**

#### **Parameters**

In case it necessary to use the regulator as “Generic PID”, independent from the feed-forward function, the parameter **Feed-fwd PID** must be set at its maximum value. In order to do this it is necessary to go through a PAD parameter.

Set **PID source** come **PAD 0**.

On **PID source** it must be set the parameter number which has to be associated, choosing it from the list of the section 10.4. “*List of high priority parameters*” (**PAD 0** has the decimal number 503).

To obtain the value, it must be added to the decimal value 8192 (fixed offset):

**PID source** = (8192 + 503) = 8695

Set **PAD 0** = 10000

(The parameter **PAD 0** is situated in the menu’ “Special Function”).

**Note:** Setting **PAD 0** = -10000, the output regulator polarity will be overturned.

Set **PID source Gain** = 1

Set **PID target** with the parameter number that has to be addressed to the output regulator.

To obtain the value it must be added the decimal value 8192.

The parameters that can be addressed are the ones described in the list of the section 10.4. “*List of high priority parameters*”.

Set **PID out scale** according to the parameter to which the regulator output has been addressed.

From the section 10.4. “*List of high priority parameters*” comes out that:

The parameters concerning the speed are expressed as [SPD].

For all the drive sizes, the rated current will be 2000 [CURR], so:

**PID out scale** = 2000/ max. output PID = 2000/ 10000 = 0.2

**Note:** In case it would be necessary to use the drive with a provisory current higher than the rated current of the drive, it is possible to increase the above described value of PID out scale. For example, if one wants to obtain 1.5 times the size, one has to set:

$$\text{PID out scale} = 0.2 \times 1.5 = 0.3$$

In this case it is necessary to enable the function of overload control “**Overload contr**” setting correctly the values **Overload current**, **Overload time**, **Base current** and **Pause Time**.

The firmware of the drive does not perform a control on the polarity of the value sent, for this reason, if it is not necessary to address the regulator output on parameters “Unsigned”, then set the PID output so that it can be positive.

**PID out. sign PID** = Only positive

The parameters “Unsigned”, for example the current limits **T current lim +** and **T current lim -**, are indicated in the “*List of high priority parameters*” with the symbol “U16”.

Set **PI central v sel** = 1.

Set **PI central v 1** = 0

In this configuration, when executing the transition Off/ On of the parameters for the enabling of the PID function, the regulator output starts from 0.

If it is necessary to retain the last value calculated also when the machine is disabled, it is necessary to use a digital input programmed as:

**Digital input xx = PI central v S0**

**PI central v 1** = 0

When the digital input is at a low logic level (L), the last value calculated is stored. Applying a high logic level (H) will reset the value.

Set **PI top lim** and **PI bottom lim** in order to obtain a correction of the PID block equal to 100% of its maximum value.

**PI top lim** = 1

**PI bottom lim** = -1

In this configuration the PID block output will be either positive and negative.

Setting **PI top lim** = 0, the positive part is blocked.

Setting **PI bottom lim** = 0, the negative part is blocked.

The gains of the various components must be set experimentally with the machine loaded.

It is possible to start the test with the following values:

Set **PI P gain PID** = 10%

Set **PI I gain PID** = 4%

Set **PD P gain PID** = 10%

Use the derivative component as damping component of the system, setting for example:

**PD D gain PID** = 5%

**PD D filter PID** = 20ms

If not necessary maintain these parameters = 0.

### 6.16.3.12 Application note

#### Dynamic modification of the integral gain of the PI block

In standard dancer applications, where there is not a build up of material, the PI gains are set to a constant value. Where dancers are used in conjunction with material winding, the gains are compromise between low gain setting at large diameter, and high gain settings at a small diameter. Using the drawing as an example, it can be seen that with a large diameter roll, the amount of material to move the dancer requires only a fraction of a turn. At a small diameter, or empty roll, the center of the roll must rotate a whole turn to move the same amount of material. Since the PI regulator is used to provide the correction in rpm to maintain the dancer position, having the gain set by a single value is inadequate when used with a winder.

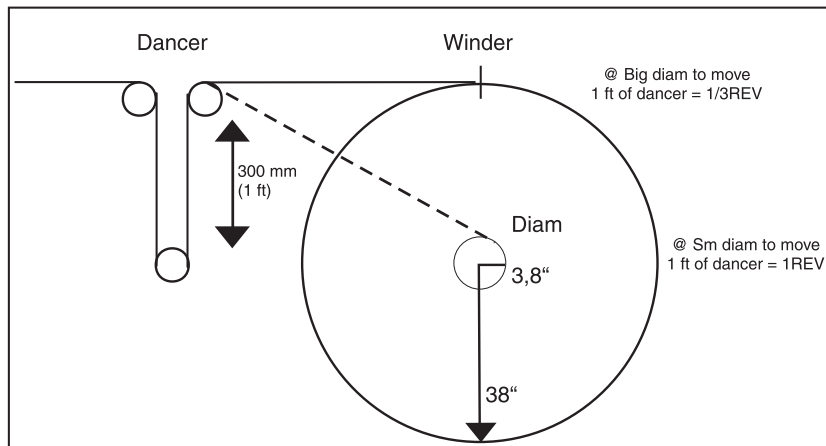

Figure 6.16.3.15: Example with small and large diameter

Better dancer control is realized if the gain of the PI is modified dynamically based on diameter. This can be accomplished using LINKS function.

In case of higher ratio diameters, **PI I gain PID** could be dynamically changed according to the actual diameter. At the moment this functionality has not been implemented as specific function.

For example to control a winder having a diameters ratio of 1/10.

The function LINK 1 is used to get a connection between the diameter and the value of the integral component of the PI block.

The integral component of the regulator must have a behaviour inversely proportional to the diameter.

The value of the parameter **PI output PID** already follows this behaviour. Infact, it changes according to the relation  $\Phi_0 / \Phi_{act}$

Where:  $\Phi_0$  = minimum roll diameter

$\Phi_{act}$  = actual roll diameter

The operation to carry out through the LINK parameter is:

**PI output PID x KI = PI I gain PID**

Where KI corresponds to the value of the integral component on minimum diameter condition.

For example, if at min diameter, the maximum speed with steady dancer in electric zero position with **PI I gain PID** = 40%.

The LINK source must be associated to **PI output PID** [n° 771]:

$$\text{Source link 1} = 8192 + 771 = 8963$$

The LINK destination must be associated to the value of the integral component= parameter **PI I gain PID** [n° 764]:

$$\text{Destination link 1} = 8192 + 764 = 8956$$

The multiplier factor must be set to the value defined by the functioning tests above mentioned.

$$\text{Mul gain link 1} = 40$$

It will be necessary to set:

$$\text{Div gain link 1} = 1000 *$$

$$\text{Input max link 1} = 1000 *$$

$$\text{Input min link 1} = 100 **$$

$$\text{Input offset link 1} = 0$$

$$\text{Output offset link 1} = 0$$

$$\text{Input absolute link 1} = \text{OFF}$$

\* The value 1000 is defined by **PI top lim** which will be in this case = 1 (correspondent to a maximum value of **PI output PID** = 1000).

\*\* The value 100 is defined by **PI bottom lim** which will be in this case = 0.1 (correspondent to a minimum value of **PI output PID** = 100).

With this configuration at minimum diameter it will correspond an integral gain = 40% and at maximum diameter it will correspond to an integral gain = 4%, between the two setpoints the gain will change with an hyperbolic characteristic.

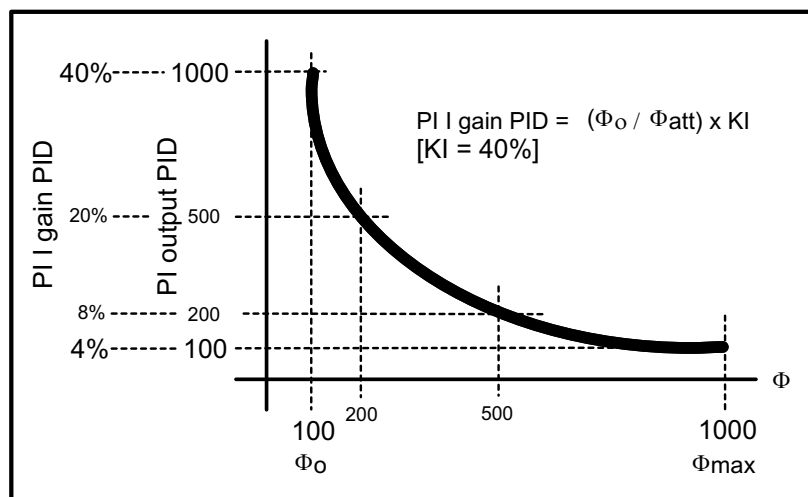

Figure 6.16.3.16: Relation between PI I gain PID and PI I output PID

The value of **PI I gain PID** will be displayed in the relative parameter of the submenu **PI controls**.

If necessary, using the LINK 2, it is possible to modify, dynamically, the proportional gain **P gain PID**.

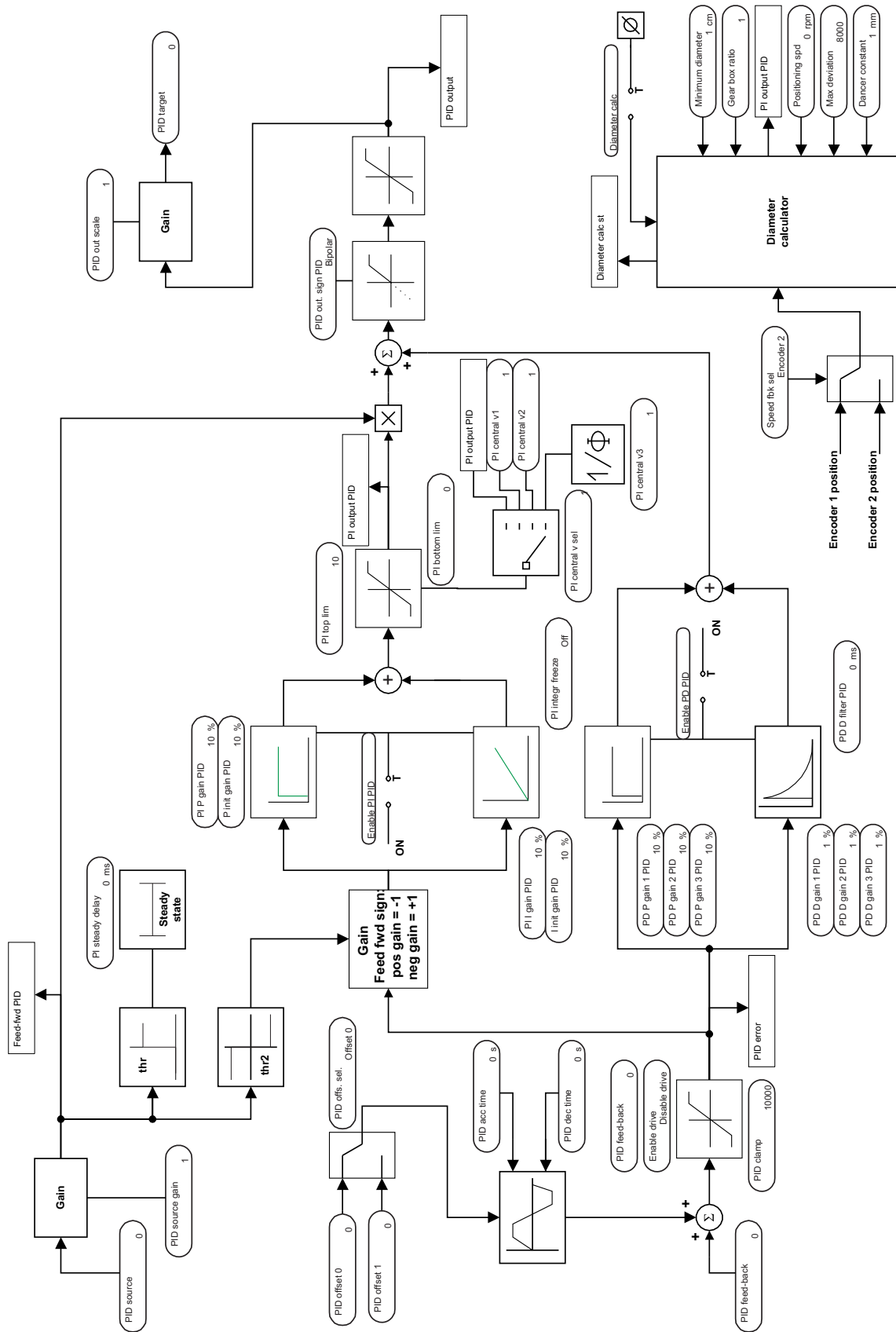

Figure 6.16.3.17: General description of the PID blocks

## 6.17 TORQUE WINDER FUNCTION

The center wind function inside the TPD32 converters is used to control winders and unwinders whose tension regulation is carried out via an open or closed loop control.

Apart from calculation functions for torque, diameter, compensation and Taper tension, the system foresees the calculation of the motor speed reference. Such function allows to use the drive on the four regulation quadrants controlling both winders and unwinders, and to control the motor with a peripheral speed proportional to the diameter in case of a break of the wound material.

The torque is adjusted according to the motor flux, thus meaning that the system is suitable to control motors with a constant torque-power ratio.

The closed loop regulation foresees an analog input for the loading cell 0...10V, 0...20mA, 4...20mA.

The output of the center wind function is sent directly to the current limits; the specific parameters T current lim +/- and the limits set by the programmable overload function are anyway active in order to protect both the inverter and the motor; among the three possible settings the one with the lowest value is always the most important.

### ***Input / Output***

|                        |  |
|------------------------|--|
| <b>Line spd source</b> | Line speed sampling parameter. It is used exclusively for the diameter calculation. The speed threshold, <b>Ref speed thr</b> , under which the calculation procedure is blocked, refers to <b>Ref line speed</b> . It can be programmed as analog input or encoder input. |
| <b>Ref spd source</b>  | Line reference sampling parameter. It is used exclusively for the calculation of:<br>- the inertia compensations<br>- the line speed reference.<br>It can be programmed as analog input or encoder input.  |

### **Analog inputs**

|                      |   |
|----------------------|---|
| <b>Tension ref</b>   | Per cent tension reference; 10V (20mA) = 100%.                |
| <b>Tension red</b>   | Per cent decrease in the Taper tension; 10V (20mA) = 100%.    |
| <b>Diam preset 3</b> | Setting of the starting diameter; 10V (20mA) = max. diameter. |

### **Analog outputs**

|                        |   |
|------------------------|---|
| <b>Roll diameter</b>   | Present diameter; 10V = max. diameter.  |
| <b>Act tension ref</b> | Tension reference decreased by the Taper percentage; 10V = 100% Tension ref.                      |
| <b>Torque current</b>  | Request for torque current; 5V = drive size.  |
| <b>W reference</b>     | Reference for angular speed, 10V = 100% Base omega.   |
| <b>Actual comp</b>     | Active compensation monitor (it sums up static, dynamic and inertial frictions); 5V = drive size. |

### **Digital inputs**

|                         |   |
|-------------------------|---|
| <b>Torque winder En</b> | Enabling of the center wind function.   |
| <b>Diam calc Dis</b>    | Enabling of the diameter calculation.   |
| <b>Diam inc/dec En</b>  | If enabled and if winder, the calculated diameter can never decrease; if unwinder the calculated diameter can never increase. It is used to improve the system stability. |
| <b>Wind/unwind</b>      | Winder/unwinder selection: 0 = winder, 1 = unwinder.  |
| <b>Winder side</b>      | Selection of the winding/unwinding side: 0 = up, 1 = down   |

|  |   |
|--|---|
| <b>Diam preset sel 0</b>   | LSD digital input; preselection of the starting diameter. |
| <b>Diam preset sel 1</b>   | MSD digital input; preselection of the starting diameter. |
| <b>Diam reset</b>  | Reset of the calculated diameter.                         |
| <b>Taper Enable</b>  | Enabling of the Taper function.                           |
| <b>Speed match</b>   | Coil “launching” phase command for automatic switching.   |
| <b>Line acc status</b>   | Active acceleration.                                      |
| <b>Line dec status</b>   | Active deceleration.                                      |
| <b>Line fstp status</b>  | Fast deceleration.  |
| The last three parameters are inputs sending to the drive the status of the line speed: they are used when the internal calculation procedure for the line acceleration is disabled. |   |
| <b>Speed demand En</b>   | Enabling of the speed reference calculation.              |
| <b>Closed loop En</b>  | Enabling of the closed loop control.                      |
| <b>Digital outputs</b>   |   |
| <b>Diameter reached</b>  | Indication: the diameter threshold has been overcome.     |
| <b>Spd match compl</b>   | Indication: the “launching” speed has been reached.       |

### 6.17.1 Diameter calculation

|                        |                       |
|------------------------|-----------------------|
| <b>OPTIONS</b>         |                       |
| <b>Torque winder</b>   |                       |
| <b>Diam Calculatio</b> |                       |
| [1154]                 | Roll diameter [m]     |
| [1160]                 | Line speed [%]        |
| [1286]                 | Ref line speed [%]    |
| [1161]                 | Diam calc Dis         |
| [1205]                 | Diam inc/dec En       |
| [1187]                 | Wind/unwind           |
| [799]                  | Minimum diameter [mm] |
| [1153]                 | Maximum diameter [m]  |
| [1204]                 | Line spd source       |
| [1284]                 | Ref spd source        |
| [1156]                 | Line speed gain       |
| [1285]                 | Ref speed gain        |
| [1163]                 | Base omega [rpm]      |
| [1155]                 | Ref speed thr [%]     |
| [1162]                 | Diam filter [ms]      |
| [1206]                 | Diam init filter [ms] |
| [1207]                 | Diam stdy delay [ms]  |
| [1157]                 | Diam reset            |
| [1158]                 | Diam thr [%]          |
| [1159]                 | Diam reached          |
| [1168]                 | Diam preset sel       |
| [1164]                 | Diam preset 0 [m]     |
| [1165]                 | Diam preset 1 [m]     |
| [1166]                 | Diam preset 2 [m]     |
| [1167]                 | Diam preset 3 [m]     |



| Parameter description                                | No.  | Value |        |                  |                  | Standard Configuration |
|--|------|-------|--------|------------------|------------------|------------------------|
|  |      | min   | max    | Factory American | Factory European |                        |
| <b>Roll diameter [m]</b>                             | 1154 | 0.000 | 32.000 |                  |                  | ****                   |
| <b>Line speed [%]</b>                                | 1160 | 0.00  | 200.00 |                  |                  |                        |
| <b>Ref line speed [%]</b>                            | 1286 | 0.00  | 200.00 |                  |                  |                        |
| <b>Diam calc Dis</b><br>ON (1) / OFF (0)             | 1161 | 0     | 1      | ON (1)           | ON (1)           | *                      |
| <b>Diam inc/dec En</b><br>Enabled (1) / Disabled (0) | 1205 | 0     | 1      | Enabled (0)      | Enabled (0)      | *                      |
| <b>Wind/unwind</b><br>Unwinder (1) / Winder (0)      | 1187 | 0     | 1      | Winder (0)       | Winder (0)       | *                      |
| <b>Minimum diameter [mm]</b>                         | 799  | 1     | 2000   | 100              | 100              |                        |
| <b>Maximum diameter [m]</b>                          | 1153 | 0.000 | 32.000 | 1.000            | 1.000            |                        |
| <b>Line spd source</b>                               | 1204 | 0     | 65535  | 0                | 0                |                        |
| <b>Ref spd source</b>                                | 1284 | 0     | 65535  | 0                | 0                |                        |
| <b>Line speed gain</b>                               | 1156 | 0     | 32767  | 0                | 0                |                        |
| <b>Ref speed gain</b>                                | 1285 | 0     | 32767  | 0                | 0                |                        |
| <b>Base omega [rpm]</b>                              | 1163 | 0     | 8191   | 1500             | 1500             |                        |
| <b>Ref speed thr [%]</b>                             | 1155 | 0     | 150.00 | 5                | 5                |                        |
| <b>Diam filter [ms]</b>                              | 1162 | 0     | 5000   | 100              | 100              |                        |
| <b>Diam init filter [ms]</b>                         | 1206 | 0     | 5000   | 100              | 100              |                        |
| <b>Diam stdy delay [ms]</b>                          | 1207 | 0     | 60000  | 0                | 0                |                        |
| <b>Diam reset</b>                                    | 1157 | 0     | 1      | 0                | 0                | *                      |
| <b>Diam thr [%]</b>                                  | 1158 | 0     | 150.00 | 10               | 10               |                        |
| <b>Diam reached</b>                                  | 1159 | 0     | 1      |                  |                  | **                     |
| <b>Diam preset sel</b>                               | 1168 | 0     | 3      | 0                | 0                | *                      |
| <b>Diam preset 0 [m]</b>                             | 1164 | 0.000 | 32.000 | 0                | 0                |                        |
| <b>Diam preset 1 [m]</b>                             | 1165 | 0.000 | 32.000 | 0                | 0                |                        |
| <b>Diam preset 2 [m]</b>                             | 1166 | 0.000 | 32.000 | 0                | 0                |                        |
| <b>Diam preset 3 [m]</b>                             | 1167 | 0.000 | 32.000 | 0                | 0                | ***                    |

\* This parameter can be set on a programmable digital input.

\*\* This parameter can be set on a programmable digital output.

\*\*\* This parameter can be set on a programmable analog input.

\*\*\*\* This parameter can be set on a programmable analog output.

The inputs received by the diameter calculator are the angular speed of the controlled motor and the line speed. The latter can be measured through an analog input or an encoder.

The value of the calculated diameter can be sent to an analog output; via a digital output it is also possible to state the overcoming of a programmable threshold.

It is possible to select four values of the starting diameters; one value can derive from an analog input.

**Roll diameter** Monitor of the calculated diameter in [m].

**Line speed** Monitor of the line speed in [%].

**Ref line speed** Reference monitor for the line speed in [%].

**Diam calc Dis** Disabling of the diameter calculation (see also par. **Ref speed thr**). In case such function is temporarily disabled during the functioning period, the system stores the last calculated value.

**Diam inc/dec En** If enabled and if winder, the calculated diameter can never decrease; if unwinder the calculated diameter can never increase. It is used to improve the system stability.

**Wind/unwind** Winder/unwinder selection. If the selection is carried out via a digital input: 0V = winder, +24V = unwinder.

**Minimum diameter** Value of the minimum diameter in [mm].

**Maximum diameter** Value of the maximum diameter in [m].

**Line spd source** Number of the sampling parameter for the line speed. In order to obtain the real number to be set, it is necessary to add +2000H (8192 decimal) to the parameter number.

Programming example for the encoder 1 (connector XE1) on **Line speed source**:

OPTION Menu  
———> Torque winder  
          ———> Diam calculation  
                  ———> Line speed source = 8619

Paragraph 10.4. “*List of the high priority parameters*” shows that **Enc 1 speed** has the decimal number 427. In order to obtain the value to be entered it is necessary to add 8192 decimal (fixed offset):  $8192 + 427 = 8619$

Programming example for the analog input 2 on **Line speed source**:

a) input programming on a PAD parameter

I/O CONFIG Menu  
———> Analog input  
          ———> Analog input 2  
                  ———> Select input 2 = PAD 0

b) setting of **PAD 0** as a line speed input:

OPTION Menu  
———> Torque winder  
          ———> Diam calculation  
                  ———> Line speed source = 8695

Paragraph 10.4. “*List of the high priority parameters*” shows that **PAD 0** has the decimal number 503. In order to obtain the value to be entered it is necessary to add 8192 decimal (fixed offset):  $8192 + 503 = 8695$

**Line speed gain** Calibration value for the line speed.

Its setting depends on the sampling parameter of the line speed; it is used to obtain “Line speed” = 100% at its maximum value

The calculation of **Line speed gain** must be carried out with the formula:

$$[32768 \times 16384 / (\text{maximum value of the sampling parameter} \times 8)] - 1$$

Programming example for the encoder 1 (connector XE1) on **Line speed source**:

If the encoder has an unknown rotation speed, the input value of the encoder 1 can be read in the

MONITOR Menu  
———> Measurements  
          ———> Speed  
                  ———> Speed in rpm  
                          ———> **Enc 1 speed**

Remember that the drive internally converts the speed in *RPM x 4*, therefore assuming to have maximum **Enc 1 speed** = 1500rpm:

$$\text{Line speed gain} = [32768 \times 16384 / (1500 \times 4 \times 8) - 1] = 11184$$

Programming example for the analog input 2 on **Line speed source**:

When an analog input is set on a PAD parameter, its maximum value is + / - 2048, therefore in order to have **Line speed** = 100%:

$$\mathbf{Line\ speed\ gain} = [32768 \times 16384 / (2048 \times 8) - 1] = 32767$$

(In order to obtain a fine tuning it is necessary to carry out the self tuning procedure of the analog input).

**Ref spd source**

**Ref speed gain**

Their functions are similar to **Line speed source** and **Line speed gain**. They can set the signal used for the calculation of the inertia compensations and of the speed reference. With the exception of particular conditions, for example a difference between the line speed and the speed reference due to the presence of a loop on the material, such values are set on the same source with the same gains.

**Base omega**

Value in [rpm] corresponding to the maximum angular speed of the winder/unwinder (motor shaft side).

**Line speed thr**

Line speed detecting threshold in %.

When “Ref line speed” is lower than “Ref speed thr” the diameter calculation is stopped. The diameter is kept at a constant value. When “Ref line speed” overcomes the threshold, the diameter calculation is enabled with an initial filter corresponding to **Diam init filter** for the time set in **Diam stdy delay**. At the end of this time the filter will be set to **Diam filter**.

**Diam filter**

Filter on the diameter calculation in [ms].

**Diam init filter**

Initial filter on the diameter calculation in [ms].

**Diam stdy delay**

Time in [ms] during which the value of **Diam init filter** is kept active after **Line speed thr** has been overcome.

**Diam reset**

Diameter reset. When this parameter is enabled, the diameter gets a starting value selected with **Diam preset sel**.

**Diam thr**

Programmable diameter threshold as a percentage of **Maximum diameter**. The threshold overcoming is detected by **Diam reached** and it can be sent to a digital output.

**Diam reached**

Indication for the overcoming of the diameter threshold.

**Diam preset sel**

Selector of the starting diameter [0...3]. **Diam preset sel** can be set directly via the keypad or serial line or via two digital inputs programmed as **Diam preset sel 0** and **Diam preset sel 1**, the selection in this case is carried out with a binary logic.

**Diam preset 0**

0 starting diameter in [m]. The setting of this value must be included between **Minimum diameter** and **Maximum diameter**.

**Diam preset 1**

1 starting diameter in [m]. The setting of this value must be included between **Minimum diameter** and **Maximum diameter**.

**Diam preset 2**

2 starting diameter in [m]. The setting of this value must be included between **Minimum diameter** and **Maximum diameter**.

**Diam preset 3**

3 starting diameter in [m]. The setting of this value must be included between **Minimum diameter** and **Maximum diameter**.

It can be assigned to an analog input, in this case 10V correspond to **Maximum diameter** and the voltage referring to the minimum diameter is = 10 x (**Minimum diameter** / **Maximum diameter**).

## 6.17.2 Torque calculation

The torque calculator is made of three blocks:

1. Torque calculation according to the winder/unwinder ray and to the set tension:  $C = T \times r$
2. Calculation of the static, dynamic and inertial compensations
3. If the Taper function is enabled, the calculation of the tension curve is made according to the ray.

The tension and Taper reduction references can be sent via an analog input, serial line or field bus. The calculation of the angular acceleration, necessary to the inertial compensations, can be carried out through a suitable internal function or by stating via three digital inputs the acceleration, deceleration and fast deceleration conditions.

The connection to the PID function belongs to the compensation block. Such connection is necessary when a closed loop tension control with loading cell is carried out.

The calculation result is sent directly to the drive current limits and can be monitored in the parameters **In use Tcur lim +** and **In use Tcur lim -** of the LIMITS menu.

The standard parameters **T current lim +/-** and the limits set by the programmable overload function are anyway active in order to protect both the inverter and the motor; the setting with the lowest value is always the most important. It is also possible to set a specific current limit for the coil “launching” function during an automatic switching. The outcoming tension value and that of the calculated torque current can be monitored on the analog outputs.

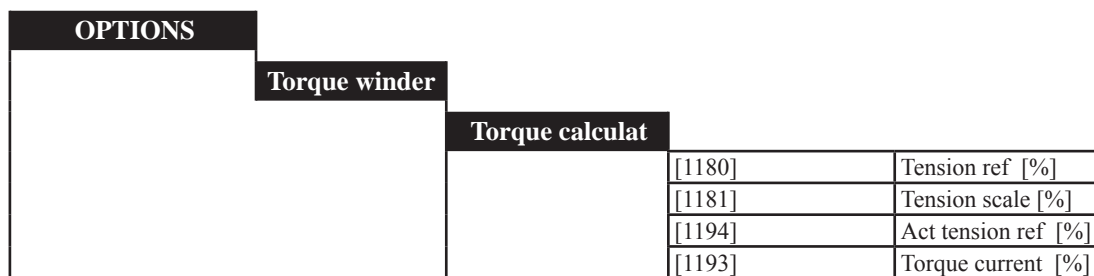

| Parameter description | No.  | Value |        |                  |                  | Standard Configuration |
|-----------------------|------|-------|--------|------------------|------------------|------------------------|
|                       |      | min   | max    | Factory American | Factory European |                        |
| Tension ref [%]       | 1180 | 0.00  | 199.99 | 0                | 0                | *                      |
| Tension scale [%]     | 1181 | 0     | 200    | 100              | 100              |                        |
| Act tension ref [%]   | 1194 | 0.00  | 199.99 |                  |                  |                        |
| Torque current [%]    | 1193 | 0.00  | 200.00 |                  |                  | **                     |

\* This parameter can be set on a programmable analog input.

\*\* This parameter can be set on a programmable analog output.

**Tension ref** Per cent tension reference.

**Tension scale** Scale factor of the torque current in %.

This parameter is used when the value of the maximum winding torque has to be limited or when a closed loop control is used in order to adjust the torque current value to the real tension on the material measured by the loading cell.

As for tuning refer to paragraph *Application example*.

**Act tension ref** Monitor of the % tension reference less the Taper percentage set via **Tension red**; if the Taper function is not enabled, it corresponds to **Tension ref**.

**Torque current** Monitor for the requirement of the torque current in %.

### 6.17.2.1 Compensations and closing of the tension loop

| OPTIONS |                      |
|---------|----------------------|
|         | Torque winder        |
|         | Torque calculat      |
|         | Comp calculat        |
| [1183]  | Int acc calc En      |
| [1182]  | Time acc/dec min [s] |
| [1212]  | Acc/dec filter [ms]  |
| [1184]  | Line acc [%]         |
| [1185]  | Line dec [%]         |
| [1186]  | Line fast stop [%]   |
| [1188]  | Line acc status      |
| [1189]  | Line dec status      |
| [1190]  | Line fstp status     |
| [1171]  | Variable J comp [%]  |
| [1172]  | Constant J comp [%]  |
| [1192]  | Act var J comp [%]   |
| [1191]  | Act const J comp [%] |
| [1173]  | Mat width [%]        |
| [1174]  | Static f [%]         |
| [1175]  | Dinamic f [%]        |
| [1287]  | Static f Zero        |
| [1213]  | Actual comp [%]      |
| [1214]  | Closed loop En       |
| [1208]  | Close loop comp      |

| Parameter description                                | No.  | Value   |         |                  |                  | Standard Configuration |
|--|------|---------|---------|------------------|------------------|------------------------|
|  |      | min     | max     | Factory American | Factory European |                        |
| <b>Int acc calc En</b><br>Enabled (1) / Disabled (0) | 1183 | 0       | 1       | Enabled (1)      | Enabled (1)      | *                      |
| <b>Time acc/dec min [s]</b>                          | 1182 | 0.15    | 300.00  | 9.01             | 9.01             |                        |
| <b>Acc/dec filter [ms]</b>                           | 1212 | 0       | 5000    | 30               | 30               |                        |
| <b>Line acc [%]</b>                                  | 1184 | 0.00    | 100.00  | 100              | 100              |                        |
| <b>Line dec [%]</b>                                  | 1185 | 0.00    | 100.00  | 100              | 100              |                        |
| <b>Line fast stop [%]</b>                            | 1186 | 0.00    | 100.00  | 100              | 100              |                        |
| <b>Line acc status</b>                               | 1188 | 0       | 1       | OFF              | OFF              | *                      |
| <b>Line dec status</b>                               | 1189 | 0       | 1       | OFF              | OFF              | *                      |
| <b>Line fstp status</b>                              | 1190 | 0       | 1       | OFF              | OFF              | *                      |
| <b>Variable J comp [%]</b>                           | 1171 | 0.00    | 199.99  | 0                | 0                |                        |
| <b>Constant J comp [%]</b>                           | 1172 | -100.00 | +100.00 | 0                | 0                |                        |
| <b>Act var J comp [%]</b>                            | 1192 | -       | 200.00  | 0                | 0                |                        |
| <b>Act const J comp [%]</b>                          | 1191 | -       | 200.00  | 0                | 0                |                        |
| <b>Mat width [%]</b>                                 | 1173 | 0.00    | 100.00  | 100              | 100              |                        |
| <b>Static f [%]</b>                                  | 1174 | 0.00    | 199.99  | 0                | 0                |                        |
| <b>Dinamic f [%]</b>                                 | 1175 | 0.00    | 199.99  | 0                | 0                |                        |
| <b>Static f Zero</b><br>Enabled (1) / Disabled (0)   | 1287 | 0       | 1       | Disabled (0)     | Disabled (0)     |                        |
| <b>Actual comp [%]</b>                               | 1213 | -200    | +200    |                  |                  | **                     |
| <b>Closed loop En</b><br>Enabled (1) / Disabled (0)  | 1214 | 0       | 1       | Disabled (0)     | Disabled (0)     |                        |
| <b>Close loop comp</b>                               | 1208 | -32767  | +32767  |                  |                  |                        |

\* This parameter can be set on a programmable digital input.

\*\* This parameter can be set on a programmable digital output.

|                         |  |
|-------------------------|--|
| <b>Int acc calc En</b>  | Enabling of the calculation of the coil acceleration.<br>If enabled this function carries out the calculation of the angular acceleration inside the drive. In this case it is necessary to set just the value of <b>Time acc/dec min</b> . If disabled, it is necessary to set the parameters <b>Line acc %</b> , <b>Line dec %</b> , <b>Fast stop %</b> and <b>Time acc/dec min</b> and to supply the corresponding status indication to the digital inputs. |
| <b>Time acc/dec min</b> | Time in [s] corresponding to the lower acceleration, deceleration and fast deceleration time.  |
| <b>Acc/dec filter</b>   | Filter in [ms] on the calculation of the acceleration inside the drive.  |
| <b>Line acc %</b>       | Acceleration time as a percentage of <b>Time acc/dec min</b> .<br>Ex: Acceleration = line deceleration = 10s<br>Fast deceleration (fast stop) = 5s<br>Time acc/dec min = 5s<br>Line acc % = $(5 / 10) \times 100 = 50\%$   |
| <b>Line dec %</b>       | Deceleration time as a percentage of <b>Time Acc/dec min</b> .<br>Ex: Acceleration = line deceleration = 10s<br>Fast deceleration (fast stop) = 5s<br>Time acc/dec min = 5s<br>Line dec % = $(5 / 10) \times 100 = 50\%$   |
| <b>Line fast stop %</b> | Fast deceleration time as a percentage of <b>Time Acc/dec min</b> .<br>Ex: Acceleration = line deceleration = 10s<br>Fast deceleration (fast stop) = 5s<br>Time acc/dec min = 5s<br>Line fast stop % = $(5 / 5) \times 100 = 100\%$  |
| <b>Line acc status</b>  | Acceleration stating input.  |
| <b>Line dec status</b>  | Deceleration stating input.<br>These two indications are combined with the drive digital outputs <b>Acc state</b> and <b>Dec state</b> (see fig. 6.17.1).  |

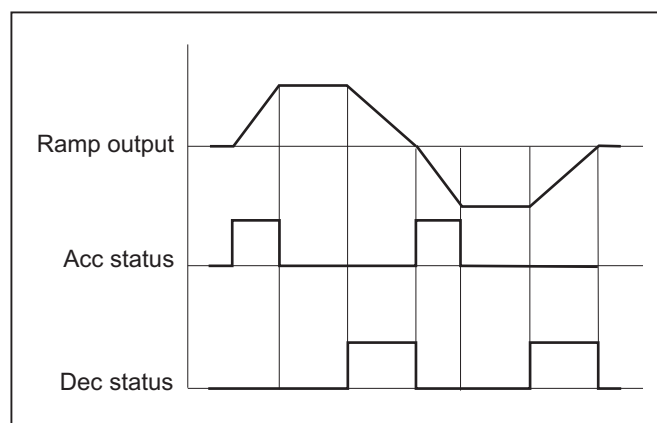
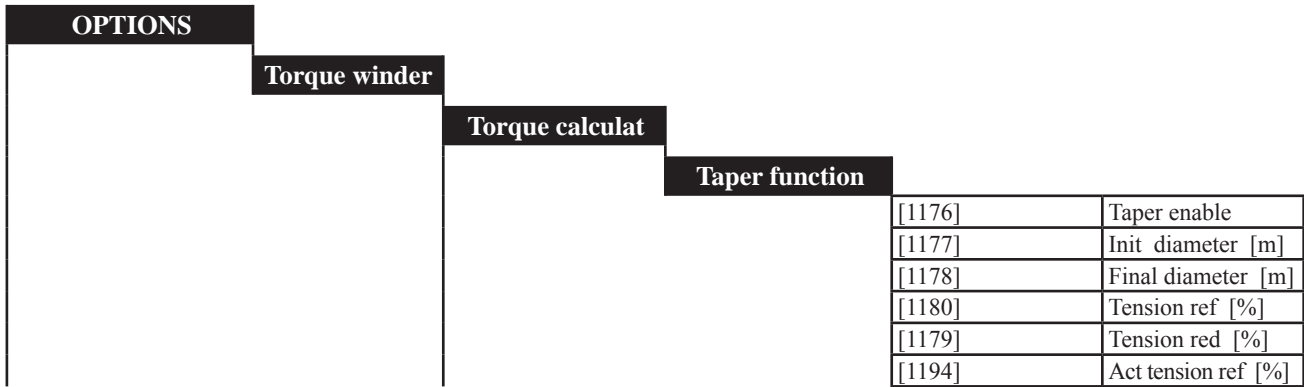

Figure 6.17.1: Acceleration and deceleration indication

|                         |  |
|-------------------------|--|
| <b>Line fstp status</b> | Indication of a fast deceleration.   |
| <b>Variable J comp</b>  | Torque compensation due to the wound material as a percentage of the drive rated current. As for tuning see the paragraph <i>Application example</i> . |

|                         |  |
|-------------------------|--|
| <b>Constant J comp</b>  | Compensation of the fixed section (motor, reducer, pin) as a percentage of the drive rated current. As for tuning see the paragraph <i>Application example</i> .   |
| <b>Act var J comp</b>   | Monitor for the active compensation of the variable section as a percentage of the drive rated current.  |
| <b>Act const J comp</b> | Monitor for the active compensation of the fixed section as a percentage of the drive rated current.   |
| <b>Mat width</b>        | Width of the wound material as a percentage of the maximum width.  |
| <b>Static f</b>         | Compensation of the static frictions as a percentage of the drive rated current. As for tuning see the paragraph <i>Application example</i> .  |
| <b>Dinamic f</b>        | Compensation of the dynamic frictions as a percentage of the drive rated current. As for tuning see the paragraph <i>Application examples</i> .  |
| <b>Static f Zero</b>    | By setting the parameter on “Enabled”, the friction compensation is completely inserted for all speed values. When it set as “Disabled”, the static friction compensation is completely inserted with Ref line speed = 1.5%. |
| <b>Act comp</b>         | Monitor for the active compensations (it sums up the static, dynamic and inertial frictions) as a percentage of the drive rated current.   |
| <b>Closed loop En</b>   | Enabling of the tension loop closing (to be used with a loading cell).   |
| <b>Closed loop comp</b> | Monitor for the active compensation, output of the PID regulator used for the loop closing.  |

### 6.17.2.2 Taper function



| Parameter description                             | No.  | Value |        |                  |                  | Standard Configuration |
|---|------|-------|--------|------------------|------------------|------------------------|
|   |      | min   | max    | Factory American | Factory European |                        |
| <b>Taper enable</b><br>Enabled (1) / Disabled (0) | 1176 | 0     | 1      | Disabled (0)     | Disabled (0)     | *                      |
| <b>Init diameter [m]</b>                          | 1177 | 0.000 | 32.000 | 0.1              | 0.1              |                        |
| <b>Final diameter [m]</b>                         | 1178 | 0.000 | 32.000 | 1                | 1                |                        |
| <b>Tension ref [%]</b>                            | 1180 | 0.00  | 199.99 | 0                | 0                | **                     |
| <b>Tension red [%]</b>                            | 1179 | 0.00  | 199.99 | 0                | 0                | **                     |
| <b>Act tension ref [%]</b>                        | 1194 | 0.00  | 200.00 | 0                | 0                | ***                    |

- \* This parameter can be set on a programmable digital input.
- \*\* This parameter can be set on a programmable analog input.
- \*\*\* This parameter can be set on a programmable analog output.

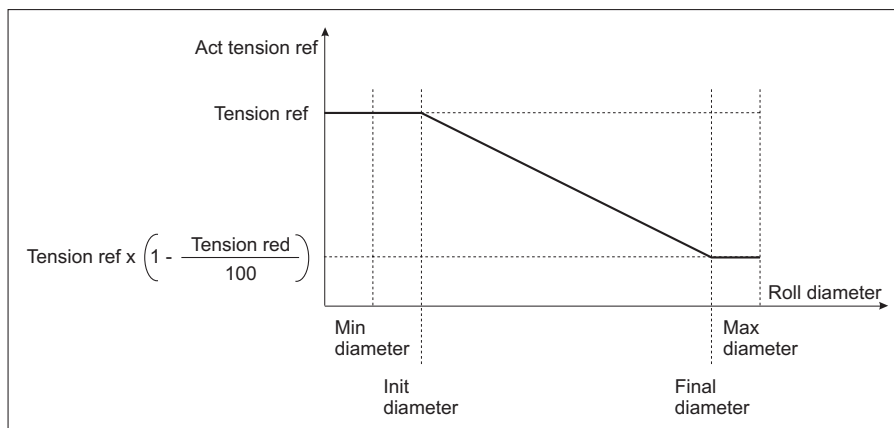

Figure 6.17.2: Relation among the Taper function parameters

- Taper enable**                    Enabling of Taper function.
- Init diameter**                    Diameter for the starting of the taper tension reduction in meters.
- Final diameter**                    Diameter for the ending of the taper tension reduction in meters.
- Tension ref**                        Tension reference in %.
- Tension red**                        Taper tension reduction as a percentage of **Tension ref**.
- Act tension ref**                    Monitor for the active tension reference as a percentage of **Tension ref**.



### 6.17.3 Calculation of the speed reference

| OPTIONS |                      |
|---------|----------------------|
|         | Torque winder        |
|         | Speed demand         |
| [1215]  | Speed demand En      |
| [1201]  | Winder side          |
| [1202]  | W gain [%]           |
| [1195]  | Speed match          |
| [1200]  | Spd match gain [%]   |
| [1196]  | Spd match acc [s]    |
| [1197]  | Spd match dec [s]    |
| [1203]  | Spd match compl      |
| [1216]  | Spd match torque [%] |
| [1199]  | W offset [rpm]       |
| [1198]  | Offset acc time [s]  |
| [1210]  | W target             |
| [1217]  | W reference [rpm]    |
| [1256]  | Jog TW enable        |
| [1255]  | Jog TW speed [%]     |

The calculation and control of the reference for the motor angular speed allow to use the drive on the four regulation quadrants both with a winder and unwinder control and to control the motor with a peripheral speed proportional to the diameter in case the wound material breaks down.

Such program block contains also the control of the coil “launching” reference during the initial and automatic switching phases with a stopped line.

The calculator output can be addressed to one of the four possible speed references of the drive or on an analog output.

| Parameter description                         | No.  | Value |        |                  |                  | Standard Configuration |
|---|------|-------|--------|------------------|------------------|------------------------|
|   |      | min   | max    | Factory American | Factory European |                        |
| Speed demand En<br>Enabled (1) / Disabled (0) | 1215 | 0     | 1      | Disabled (0)     | Disabled (0)     |                        |
| Winder side<br>Down (1) / Up (0)              | 1201 | 0     | 1      | Up (0)           | Up (0)           |                        |
| W gain [%]                                    | 1202 | 0     | 100    | 0                | 0                |                        |
| Speed match<br>ON (1) / OFF (0)               | 1195 | 0     | 1      | OFF (0)          | OFF (0)          |                        |
| Spd match gain [%]                            | 1200 | 0     | 150    | 100              | 100              |                        |
| Spd match acc [s]                             | 1196 | 0.30  | 300.00 | 83.88            | 83.88            |                        |
| Spd match dec [s]                             | 1197 | 0.30  | 300.00 | 83.88            | 83.88            |                        |
| Spd match compl                               | 1203 | 0     | 1      |                  |                  |                        |
| Spd match torque [%]                          | 1216 | 0     | 200    | 100              | 100              |                        |
| W offset [rpm]                                | 1199 | 0     | 1000   | 0                | 0                |                        |
| Offset acc time [s]                           | 1198 | 0.30  | 950.00 | 83.88            | 83.88            |                        |
| W target                                      | 1210 | 0     | 65535  | 0                | 0                |                        |
| W reference [rpm]                             | 1217 | -8192 | +8192  |                  |                  |                        |
| Jog TW enable<br>Enabled (1) / Disabled (0)   | 1256 | 0     | 1      | Disabled (0)     | Disabled (0)     |                        |
| Jog TW speed [%]                              | 1255 | 0     | 100    | 0                | 0                |                        |

\* This parameter can be set on a programmable digital input.

\*\* This parameter can be set on a programmable digital output.

\*\*\* This parameter can be set on a programmable analog output.

|                         |  |
|-------------------------|--|
| <b>Speed demand En</b>  | Speed reference calculation enabled.   |
| <b>Winder side</b>      | Selection of the winding/unwinding side: 0 = up, 1 = down  |
| <b>W gain</b>           | Setting of the speed reference gain used to saturate the loop. Parameter as a percentage of the increasing/decreasing value of the angular speed reference.                            |
| <b>Speed match</b>      | Command of the coil “launching” phase for an automatic switching.  |
| <b>Spd match gain</b>   | Setting of the speed reference gain during the launching phase, 100% corresponds to a peripheral speed equal to the line speed.  |
| <b>Spd match acc</b>    | Motor acceleration time during the launching phase, in [s].  |
| <b>Spd match dec</b>    | Motor deceleration time in [s] if during the launching phase a stop command is given.  |
| <b>Spd match compl</b>  | Indication of a completed launching ramp, if it is programmed on a digital output it can be used to state that the coil can be changed.  |
| <b>Spd match torque</b> | Setting of the torque current during the launching and change phase. The parameter is given as a percentage of the drive rated current.  |
| <b>W offset</b>         | Offset setting on the speed reference for the initial phase of the winder/unwinder when the line is stopped. The parameter is given in [rpm].  |
| <b>Offset acc time</b>  | Setting of the ramp for the initial phase when the machine is stopped. The parameter is given in [s]. It refers to <b>Speed base value</b> .   |
| <b>W target</b>         | Parameter number where the speed reference has to be addressed to. In order to obtain the real number to be set, it is necessary to add +2000H (8192 decimal) to the parameter number. |

1. Addressing example on the speed reference 2:

```

OPTION Menu
—————> Torque winder
                —————> Speed demand
                        —————> W target = 8235
```

Paragraph 10.4. “List of the high priority parameters” shows that **Speed ref 2** has the decimal number 43. In order to obtain the value to be entered, it is necessary to add 8192 decimal (fixed offset):  $8192 + 427 = 8235$

|                      |  |
|----------------------|--|
| <b>W reference</b>   | Monitor for the speed reference.   |
| <b>Jog TW enable</b> | Jog function enabled.  |
| <b>Jog TW speed</b>  | Reference setting for Jog function. The parameter is given as a % of <b>Line speed</b> . |

## Control of the speed reference

In order to calculate the speed reference during the different functioning phases of the machine, a status logic has been developed. The status sequence and the operativeness is described in the figure 6.17.3.

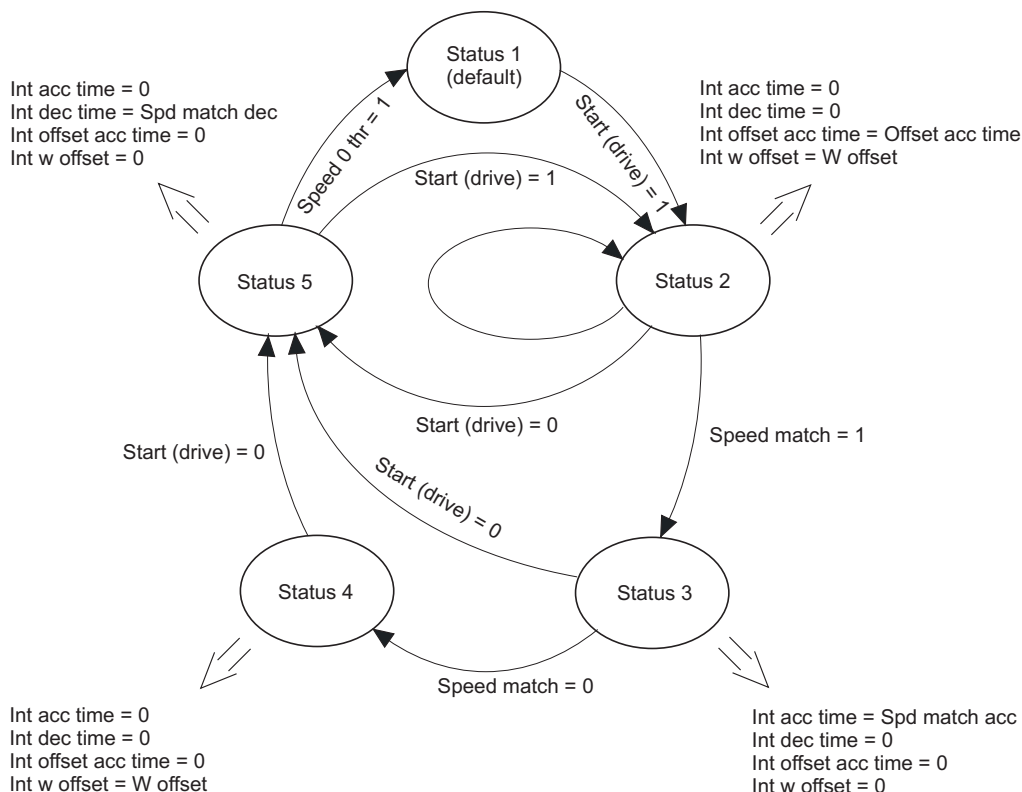

Figure 6.17.3: Operative sequence of the functioning status

### Status 1:

Default status, this system condition is given when the drive is in a Stop condition. The speed reference is zero.

### Status 2:

The system reaches this status when the Start command is given.

When the line is stopped, the initial phase reference **W offset** is assigned with the ramp time **Offset acc time**.

When the line is started, the motor speed reference follows its profile with a value corresponding to:

$$W \text{ reference} = \pm \text{Line speed} \times (\text{Minimum diameter} \div \text{Roll diameter}) \pm (W \text{ gain } \% + W \text{ offset})$$

the sign of:

$$\pm \text{Line speed} \times (\text{Minumum diameter} \div \text{Roll diameter})$$

is positive if **Wind/unwind** = winder

is negative if **Wind/unwind** = unwinder

the sign of:

$$\pm (W \text{ gain } \% + W \text{ offset})$$

is usually positive, it could be changed only if during the acceleration or deceleration phases a torque inversion is required.

The polarity of **W reference** will be further inverted if **Winder side** = 1

(winding/unwinding down).

If during a Status 1 functioning period the system receives a Stop command (Start drive = 0), the Status 5 is forced.

### Status 3:

The system reaches this status if the command **Speed match** = 1 and the Start command are given.

Starting from a Stop condition, if these commands are given, the motor speed reference is set with: **W reference** =  $[\pm \text{Line speed} \times (\text{Min dia} \div \text{Roll dia}) \pm (\text{W gain \%} * \text{W offset})] \times \text{Spd match gain}$

where **W offset** is forced to 0 with a ramp time set to **Spd match acc**.

If during a Status 3 functioning period the command **Speed match** is set at zero, the Status 4 is forced.

If during a Status 3 functioning period the system receives a Stop command (Start drive = 0), the Status 5 is forced.

### Status 4:

The system reaches this status if starting from the Status 3 the command **Speed match** is set at zero.

It usually happens simultaneously with the cutting and coil change command.

In this status the motor speed reference is set to:

**W reference** =  $\pm \text{Line speed} \times (\text{Minimum diameter} \div \text{Roll diameter}) \pm (\text{W gain \%} + \text{W offset})$

all the internal ramp times for the reference calculation are set at zero.

If during a Status 4 functioning period the system receives a Stop command (Start drive = 0), the Status 5 is set at zero.

### Status 5:

The system reaches this status through the Status 2, 3, and 4 if it receives a Stop command (Start drive = 0).

It usually happens:

- a) after an automatic switching in order to stop the rotating coil.

The speed reference is set at zero with a ramp time set to **Spd match dec**.

The parameter **W offset** is immediately set at zero in order to slow down the coil starting from the present speed

- b) After the line stop if the tension has to be removed (in this case the drive has to be disabled).

Anyway, when the speed = 0 has been reached, the system switches automatically to the Status 1.

### Status 6:

The system reaches this status when the parameter **Jog TW enable** is enabled and the Start command has been given. The Jog command is used on unwinders in order to bring the coil material till the first nip roll. See figure 6.17.4.

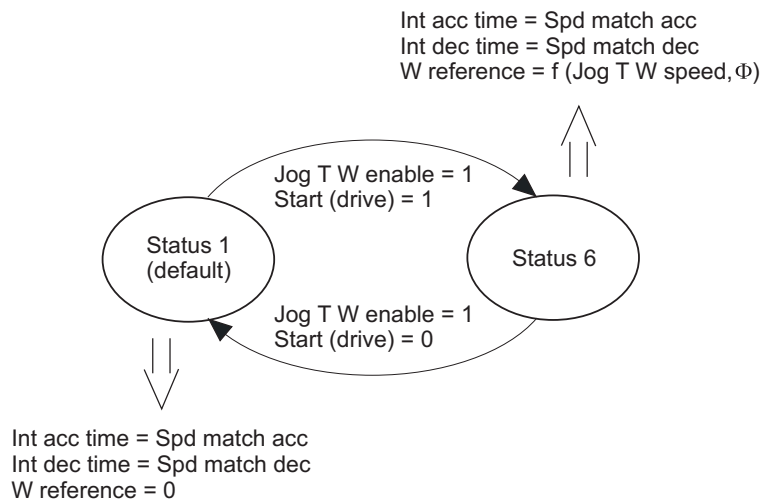

Figure 6.17.4: Functioning with Jog TW enable

**Jog TW enable** prepares the system for a particular functioning condition; in order to enable the coil rotation it is necessary to give the Start command, a following Stop will force the speed reference to 0 (see paragraph *Control logic*).

In the Status 6 the motor speed reference is set to:

$$W \text{ reference} = \text{Jog TW speed} \times \text{Minimum diameter} \div \text{Roll diameter}$$

It is possible to change the Jog speed sign by using the command **Winder side**.

If starting from the Status 6, **Jog TW enable** is disabled by keeping the Start command, the system switches to the Status 2.

### 6.17.4 Typical connection diagrams

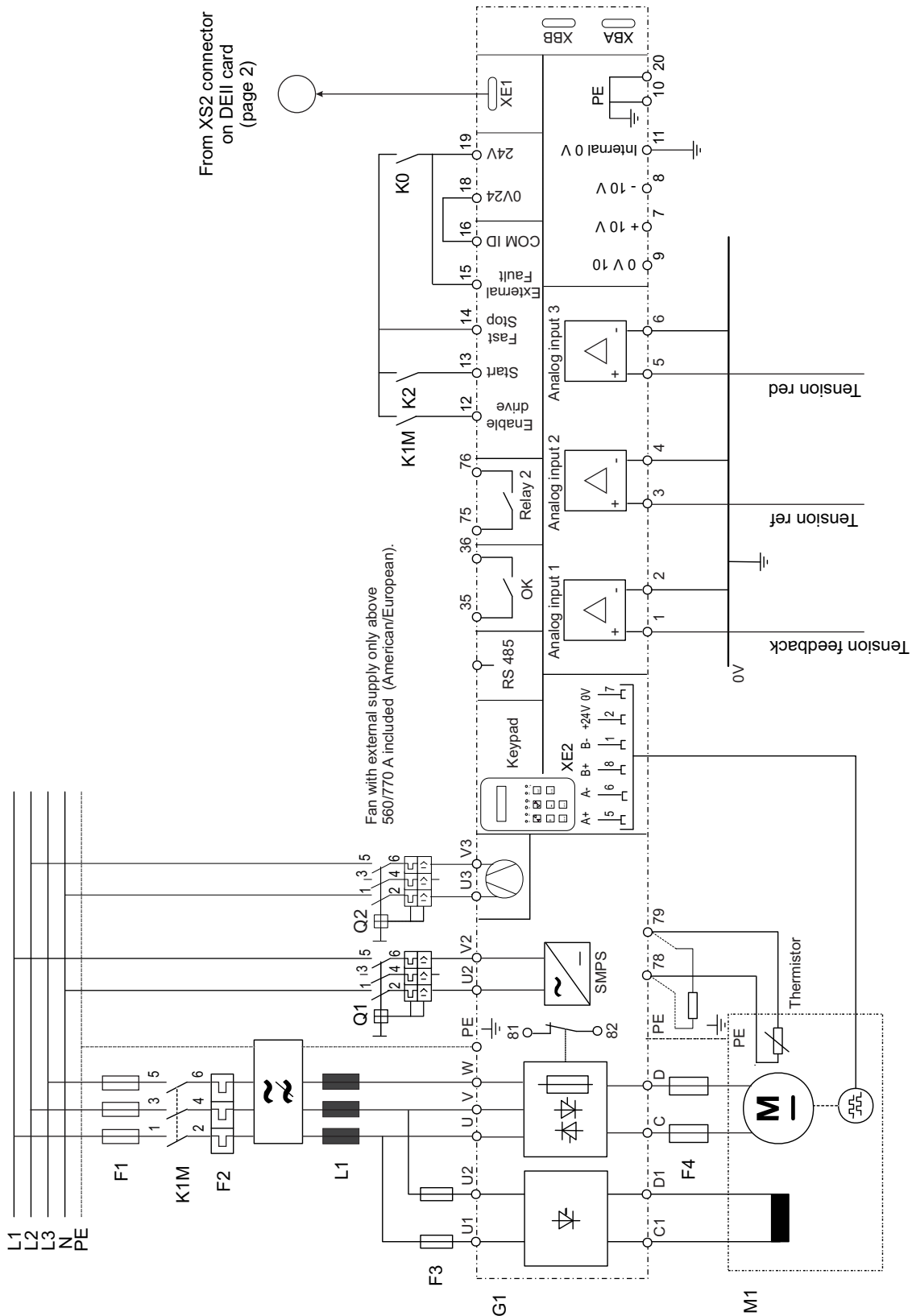
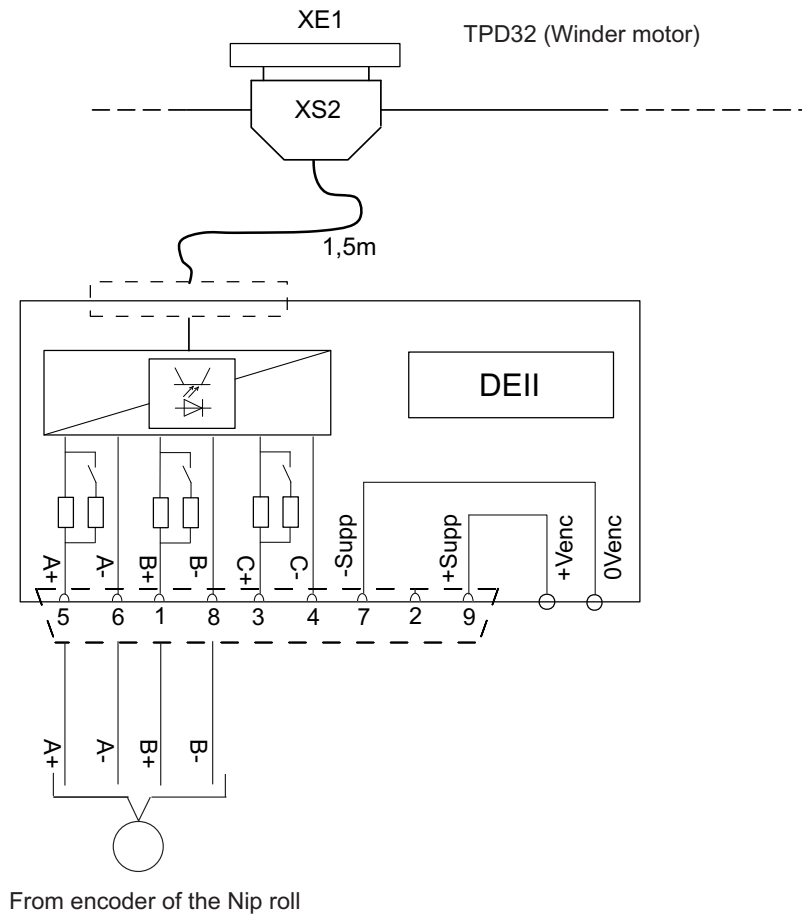

Figure 6.17.5: Winder with an automatic switch and a closed loop tension regulation



*Figure 6.17.6: Winder with an automatic switch and a closed loop tension regulation  
(Interface card of the second encoder)*

I/O expansion card on TPD32 winder motor (connector XBA)

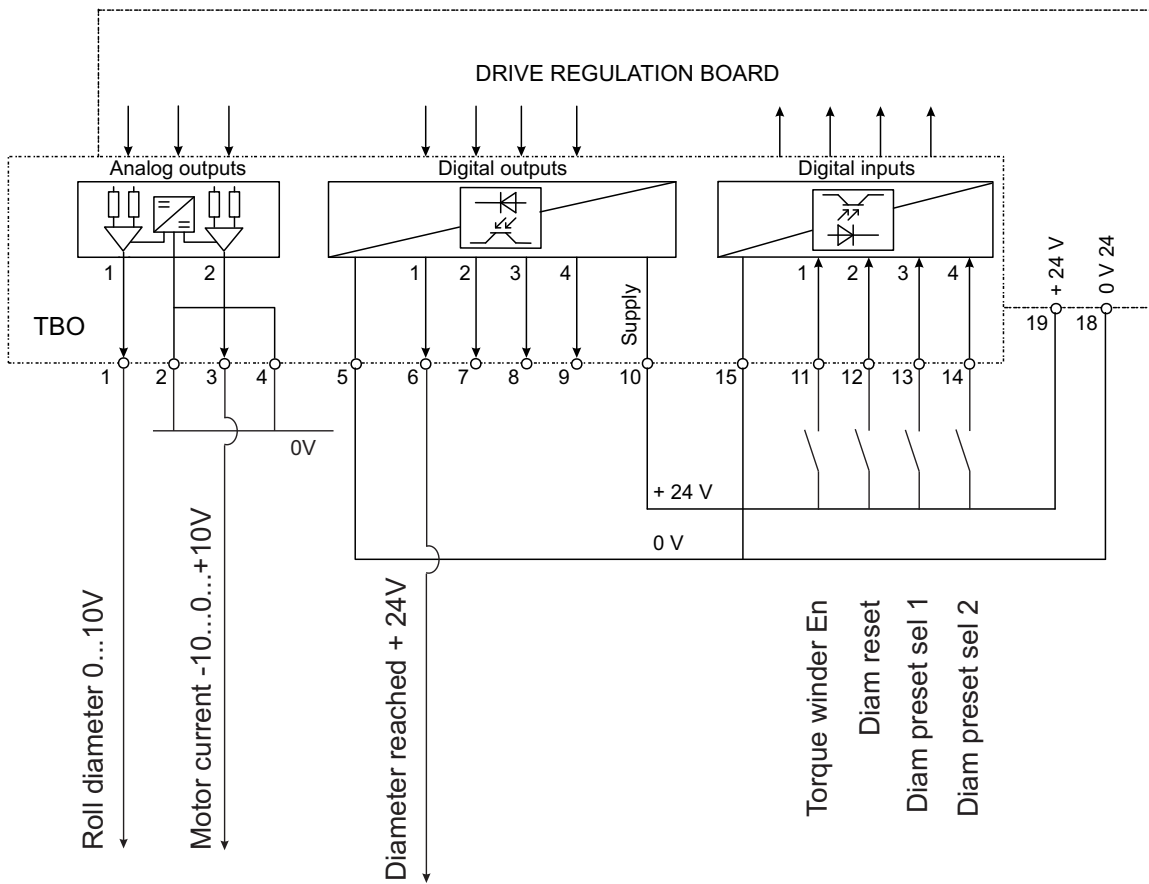

Figure 6.17.7: Winder with an automatic switch and a closed loop tension regulation (I/O expansion card)



I/O expansion card on TPD32 winder motor (connector XBB)

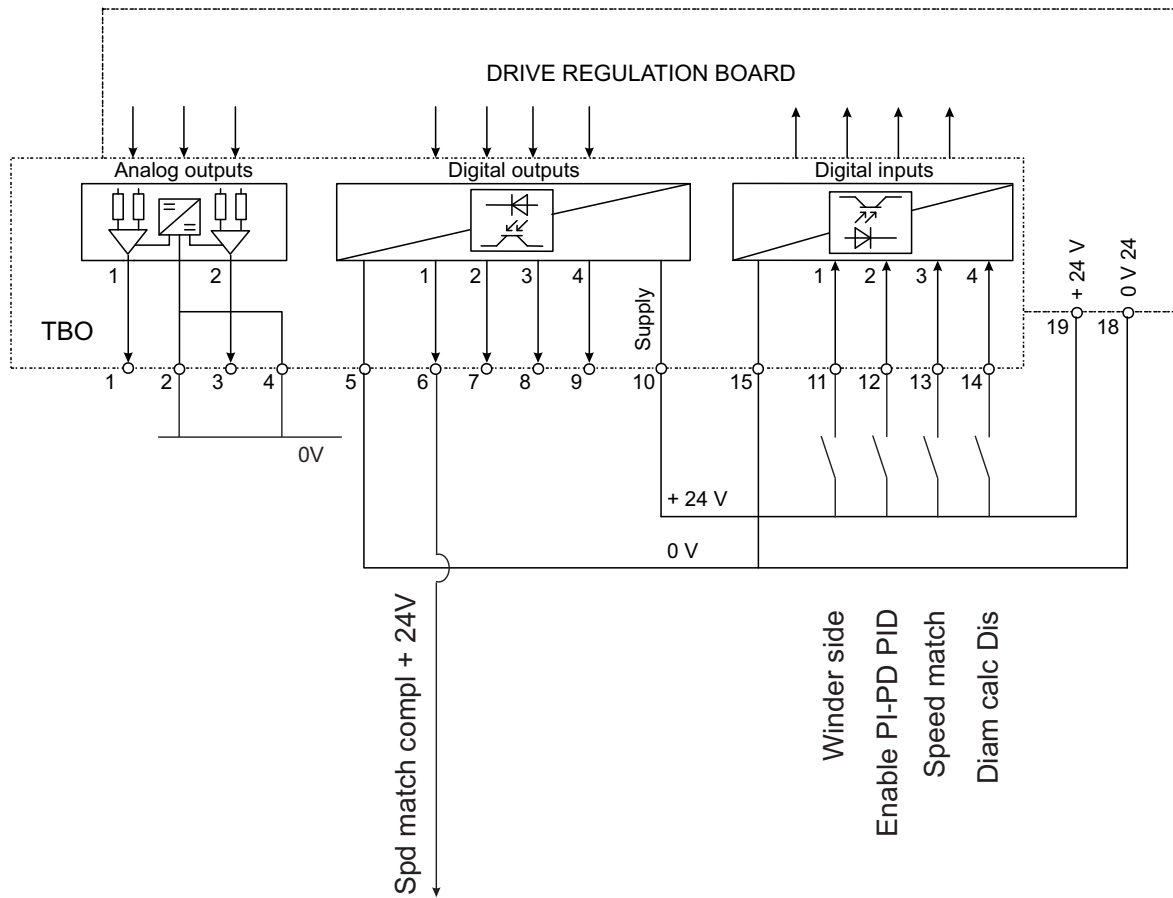

Figure 6.17.8: Winder with an automatic switch and a closed loop tension regulation (I/O expansion card)

## 6.17.5 Control logic

This chapter describes the most common logic sequences:

1. Diameter initialization
2. Initial phase
3. Automatic switch
4. Coil stop
5. Jog function

### Diameter initialization

This sequence is carried out before the starting of a winder/unwinder both with a coil initial phase when the line is stopped and during an automatic switching.

The diameter value set in **Roll diameter** depends on the parameters **Diam preset 0, 1, 2, 3** and on **Diam preset sel**.

If 2-4 different values of the starting diameter have been set, the selection has to be carried out via some programmed digital inputs such as **Diam preset sel 0** and **Diam preset sel 1**, or via the parameter **Diam preset sel**.

If the value of the starting diameter is set via an analog input, set **Diam preset sel = 3**.

Enable the parameter **Diam reset** for a time longer than 20ms.

Reset the digital input status before the start.

### Initial phase

This sequence is carried out in order to start the initial phase with a stopped line.

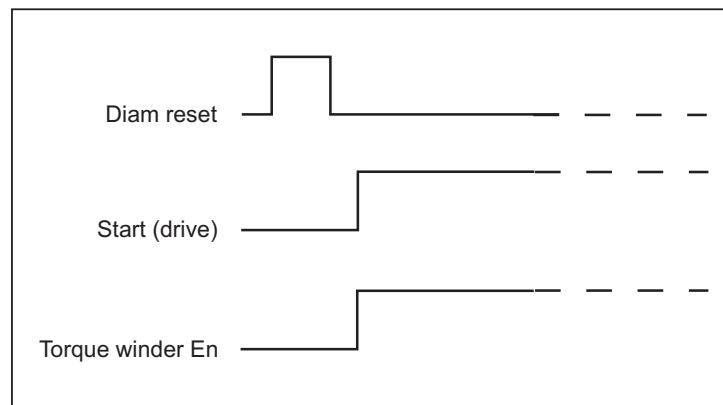

Figure 6.17.9: Initial phase with a stopped line

Initialize the diameter value as stated above.

Enable the tension control and give the start command to the drive.

If the speed reference calculation is carried out inside the drive (**Speed demand en = Enable**) the initial phase is started with the reference set to **W offset** and with a ramp time **Offset acc time**.

Now the line can be started.

## Automatic switching

This sequence carries out an automatic switching between two coils during a winding/unwinding period.

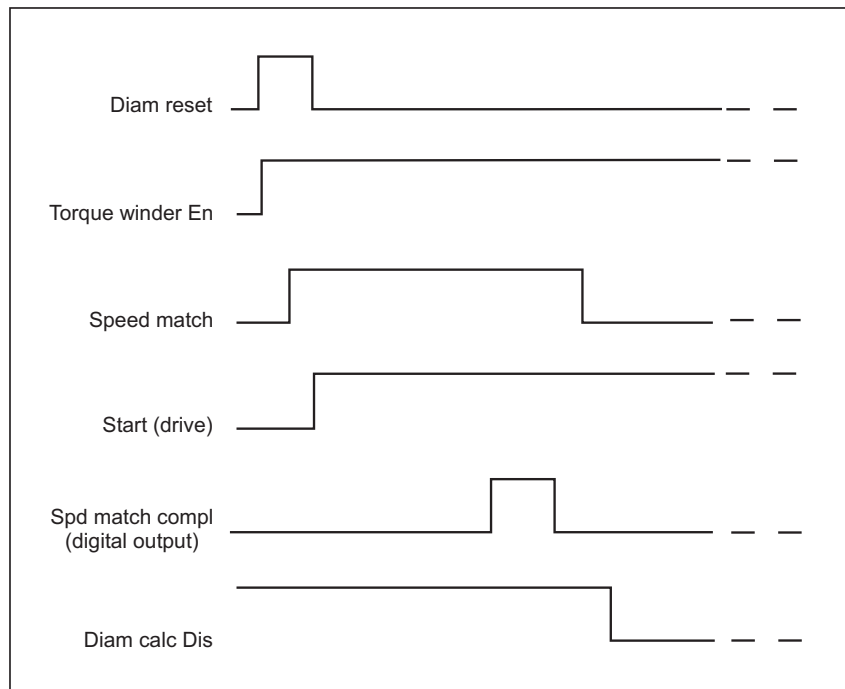

Figure 6.17.10: Automatic switching between two coils during a winding/unwinding period

a) Commands referring to the old coil:

During the star rotation phase it is advisable to disable the diameter calculation of the coil functioning as **Diam calc dis** = 1 in order to avoid errors in the diameter calculation.

b) Commands referring to the new coil:

Initialize the diameter value as stated above.

Enable the command **Speed match**, **Torque winder en** and give the start command to the drive. The motor will increase the coil speed till a peripheral speed has been reached which corresponds to the line speed for **Spd match gain** with the ramp set to **Spd match acc**. After reaching such speed, the drive indicates the end of the launching phase with the parameter **Spd match compl**.

Disable the command **Spd match** simultaneously to the switching between the two coils.

Enable the diameter calculation: **Diam calc dis** = 0.

## Reel stop

This sequence is used to stop the ended reel after carrying out the automatic switching.

Disabled the diameter calculation **Diam calc Dis** = 1 and Start command. The reel will decrease up to zero speed with the time set on **Spd match dec**.

At speed = 0 disabled **Torque winder en**.

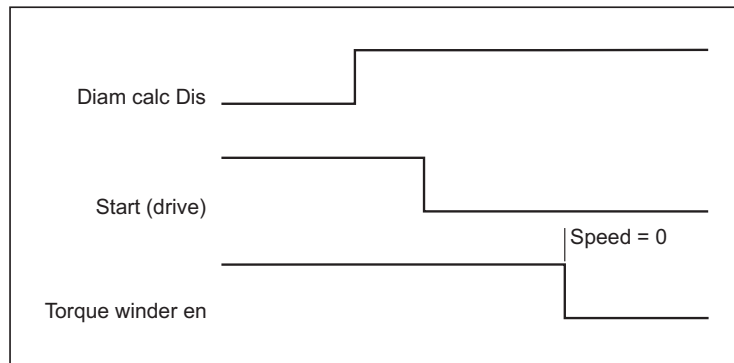

Figure 6.17.11: Coil stop after the automatic switching

### Jog function

This sequence is used in particular on unwinders in order to bring the coil material till the first nip roll.

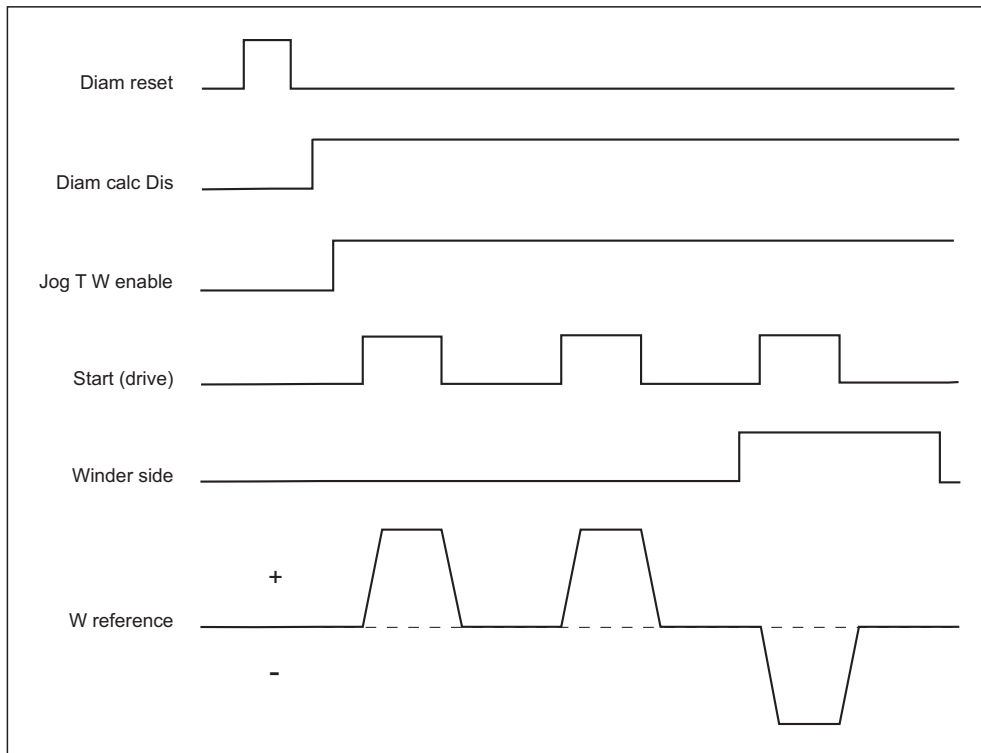

Figure 6.17.12: Jog function to prepare the machine

Initialize the diameter value as stated above.

Disable the diameter calculation. Enable **Jog TW enable**.

Use the Start/stop command to carry out the Jog function.

With the Start the motor increases the coil speed till reaching the peripheral speed set in **Jog TW speed** with the ramp time **Spd match acc**.

With the Stop the motor decreases its speed till reaching the 0 speed with the ramp time **Spd match dec**.

In order to change the rotation direction use the command **Winder side**.

## 6.17.6 Application example

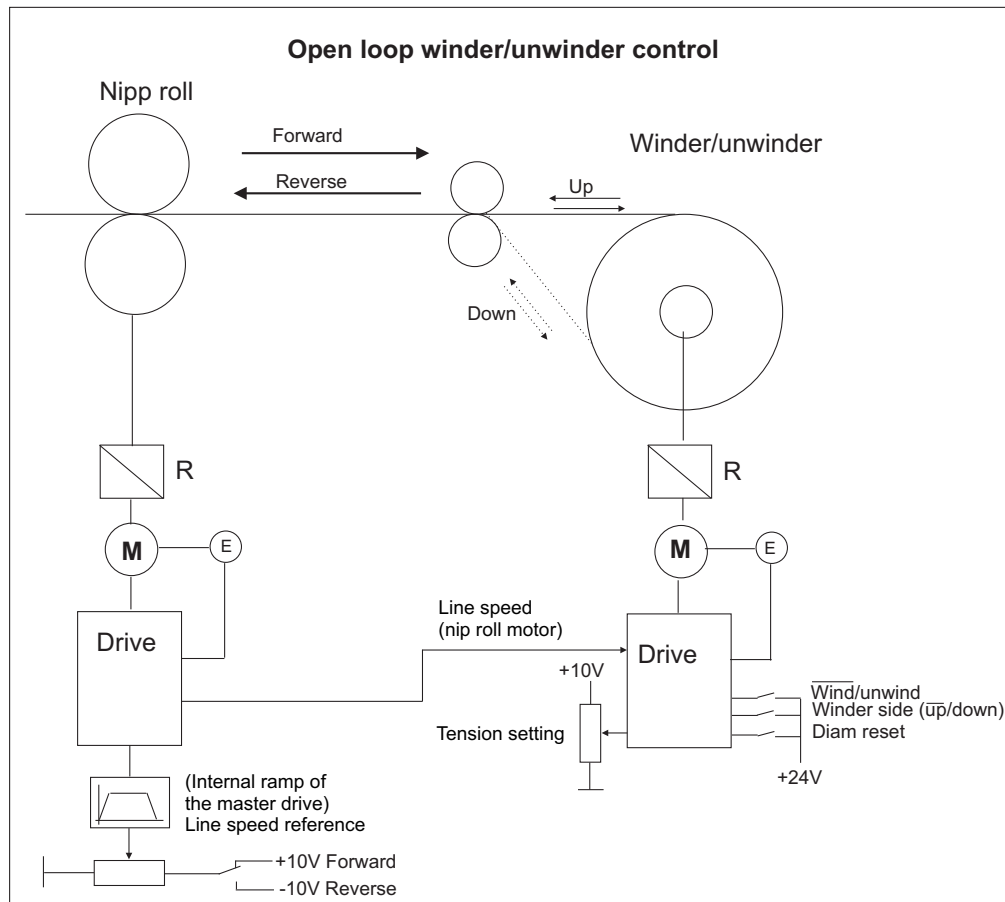

### Machine data:

- Maximum line speed=400m/min
- Rated speed of the winder motor  $V_n=3000\text{rpm}$
- Winder maximum diameter=0.7m
- Winder minimum diameter=100mm
- Motor - winder reduction ratio=0.5
- Line speed reference 0-10V from nip roll motor.
- Line acceleration/deceleration time =30sec.
- Fast deceleration time fast/stop=15 sec.
- Winder/unwinder selection via a digital input.
- Winding side selection (up/down) via a digital input.
- Tension setting via the analog input.

The winder/unwinder drive receives the analog signals referring to the line speed, to the tension setting, to the digital commands for the winder/unwinder selection, winding side (up/down), and to the diameter reset.  
 Drive settings:(only the settings referring to the function Torque Winder are described)

## PROGRAMMING OF ANALOG INPUTS

### ANALOG INPUT 1

**Tension ref** Tension reference in %;10V (20mA)=100%

I/O CONFIG Menu

—————> Analog input  
—————> Analog input 1  
—————> Select input 1 **Tension ref**:

### ANALOG INPUT 2

If the parameter **Line spd source** has to be set on an analog input, as this parameter is not listed among the high priority parameters, it is necessary to pass through a support parameter PAD0...PAD15.

**Line spd source**: 10V (20mA)=100%

Programming of the analog input 2 on **PAD 0**:

I/O CONFIG Menu

—————> Analog input  
—————> Analog input 2  
—————> Select input 2 = PAD 0

### ANALOG INPUT 3

If the parameter **Ref spd source** has to be set on an analog input, as this parameter is not listed among the high priority parameters, it is necessary to pass through a support parameter PAD0...PAD15.

**Ref spd source**: 10V (20mA)=100%

Programming of the analog input 2 on **PAD 1**:

I/O CONFIG Menu

—————> Analog input  
—————> Analog input 3  
—————> Select input 3 = PAD 1

## PROGRAMMING OF DIGITAL INPUTS

### DIGITAL INPUT 1

**Diam calc Dis**: Disabling of the diameter calculation (see also par. **Line speed thr**). In case during the functioning period it is temporarily disabled, the system stores the last calculated value. This function has to be enabled only if the application requires it.

I/O CONFIG Menu

—————> digital input  
—————> digital input 1: **Diam calc Dis**:

### DIGITAL INPUT 2

**Wind/unwind** Winder/unwinder selection. In case the selection is carried out via the digital input: 0V =Winder, +24V = Unwinder.

### DIGITAL INPUT 3

**Winder side** Selection of the winding/unwinding side: in case the selection is carried out via a digital input: 0 =UP, 1 = Down

### DIGITAL INPUT 4

**Diam reset** Diameter reset. When this parameter is enabled, the diameter gets the starting value selected with **Diam preset sel**.

If 2-4 different values of the starting diameter have been set, the selection has to be carried out via some programmed digital inputs such as: **Diam preset sel 0- Diam preset sel 0**

If the value of the starting diameter is set via an analog input, set **Diam preset sel = 3**.

In case of a winder control, it is necessary to give a reset command every time a coil change is performed by setting the minimum diameter value (winder empty diam.)

In case of an unwinder control, it is necessary to give a reset command every time a coil change is performed by setting the maximum diameter value(winder maximum diam.).

Enable the parameter **Diam reset** for a time longer than 20ms.

Reset the digital input status before the start

### DIGITAL INPUT 5

**Diam preset sel 0**

### DIGITAL INPUT 6

**Diam preset sel 1**

In case of a system with a winder or unwinder control, it is possible to set in **Diam preset 0** the value of the starting diameter; for the winder control a minimum diameter, for the unwinder control a maximum diameter. Set **Diam preset sel =0** (do not set any digital input as diam preset sel 0-diam preset 1). By starting the command of **Diam reset** the value of diam preset 0 is entered in **Roll diameter**.

OPTION Menu

—————> Torque winder

**Torque winder En ;** set **Enable** to enable the center wind function.

If the system requires it, it is possible to set this function (enable/disable)also via a digital input.

### Setting of the parameters in the DIAMETER CALCULATION menu

#### PARAMETERS

OPTION Menu

—————> Torque winder

—————> Diam calculation

**Wind/unwind** Winder/unwinder selection. Selection to be carried out only if the digital inputs are not set.

**Minimum diameter** Minimum diameter value in [mm]. Set 100mm

**Maximum diameter** Maximum diameter value in [m]. Set 0.7m

**Line spd source**      Number of the sampling parameter of the line speed. In order to get the real number to be set it is necessary to add +2000H (8192 decimal) to the parameter number.

Setting of **PAD 0** as a line speed input:

OPTION Menu

—————> Torque winder

—————> Diam calculation

—————> Line speed source = 8695

**Line speed gain**      Calibration value of the line speed.

Its programming depends on the sampling parameter of the line speed; it is used to get “Line speed” = 100% of its maximum value.

The calculation of **Line speed gain** must be carried out with the formula:

$$[32768 \times 16384 / (\text{maximum value of the sampling parameter} \times 8)] - 1$$

When this analog input is set on a PAD parameter, its maximum value is + / - 2048, therefore to have **Line speed** = 100%:

$$\text{Line speed gain} = [32768 \times 16384 / (2048 \times 8) - 1] = 32767$$

(A fine tuning can be obtained by carrying out the self tuning procedure of the analog input).

**Ref spd source**      Sampling parameter number relating to the line speed reference. In order to get the real number to be set it is necessary to add +2000H (8192 decimal) to the parameter number.

Setting of **PAD 0** as a line speed input:

OPTION Menu

—————> Torque winder

—————> Diam calculation

—————> Ref speed source = 8695

**Ref speed gain**      Gauging value of the line speed reference.

The relative setting depends on the sampling parameter of the line speed reference and is used to obtain “Line speed” = 100% at its peak.

The calculation of **Ref speed gain** must be carried out with the formula:

$$[32768 \times 16384 / (\text{maximum value of the sampling parameter} \times 8)] - 1$$

When this analog input is set on a PAD parameter, its maximum value is + / - 2048, therefore to have **Ref line spd** = 100%:

$$\text{Ref speed gain} = [32768 \times 16384 / (2048 \times 8) - 1] = 32767$$

(A fine tuning can be obtained by carrying out the self tuning procedure of the analog input).

**Line speed**      Monitor of the line speed in [%]. After programming line speed source and line speed gain it is possible to control the tuning by checking that with a line speed at its maximum value the parameter line speed =100%.

**Ref line speed**      Line reference Monitor.



**Base omega** Value in [rpm] corresponding to the maximum angular speed of the winder/unwinder (motor shaft side).  
 $V_p = \pi \times \Phi_{min} \times \omega \times R$   
 where :  
 $V_p$  = peripheral speed  
 $\Phi_{min}$  = winder minimum diameter (mm)  
 $\omega$  = motor angular speed  
 $R$  = reduction ratio  
 $\omega = V_p / \pi \times \Phi_{min} \times R = 400 / (3.14 \times 0.1 \times 0.5) = 2547 \text{rpm}$   
 Base omega = set 2547rpm.

**Ref speed thr** Line speed detecting threshold in %.  
 When “Line speed” is lower than “Line speed thr” the diameter calculation is disabled.  
 When “Line speed” is higher than the threshold, the diameter calculation is enabled with an initial filter corresponding to **Diam init filter** for the time set in **Diam stdy delay**. At the end of this time the filter is set to **Diam filter**.  
 Maximum line speed = 400m/min . Line speed thr = 5% (the diameter calculation is automatically enabled at 20m/min).

**Setting of the parameters in the SPEED DEMAND menu**  
 PARAMETERS

OPTION Menu

- > Torque winder
- > Speed demand

**Speed demand En** Enabling of the speed reference calculation; set **Enable**

**Winder side** Selection of the winding/unwinding side. Selection to be carried out only if the digital inputs are not set. 0 = up, 1 = down

**W gain** Setting of the speed reference gain used for the loop saturation. Parameter given as a percentage of the increase/decrease of the angular speed reference.  
**W gain** = 30% (set this starting value)

**W offset** Offset setting on the speed reference for the winder/unwinder initial phase with a stopped line. Parameter in [rpm].  
**W offset** = 50rpm (check with the material)

**Offset acc time** Setting of the initial phase ramp with a stopped machine. Parameter in [s]. The acc time refers to the parameter **speed base value**

**W target** Parameter number which the speed reference has to be addressed to. In order to obtain the real number to be set it is necessary to add +2000H (8192 decimal) to the parameter number.  
**W target** : set 2 as a speed reference:

OPTION Menu

- > Torque winder
- > Speed demand
- > W target = 8235

Paragraph 10.4. “List of the high priority parameters’ shows that **Speed ref 2** has the decimal number 43. In order to obtain the value to be entered add 8192 decimal (fixed offset):  $8192 + 427 = 8235$

**W reference:** It is possible to use it as a monitor for the speed reference.

### Setting of the parameters in the COMP CALCULATION menu

OPTION Menu

—————> Torque winder  
                  —————> torque calculation  
                                  —————> comp calculation

**Static f:** Compensation of the static frictions as a percentage of the drive rated current

- Check that the parameters **Static f** and **Dinamic f=0**
- Set the tension (tension ref)=0
- The diameter calculation function is blocked (enable the programmed digital input as Dis diam calc)
- Operations to be carried out without line reference, jog function and materials on the machine (the compensation of the static frictions is completely entered only when the line speed is higher than 1.5%).
- Stopped winder/unwinder motor within the current limit (In use t curr lim+/-=0)
- Gradually increase the value of **Static f**. The motor will start rotating. Set a suitable value so that the winder/unwinder can rotate with a speed near to the zero (it must always be within the current limit. The led Ilim on the keypad is lighted)

**Dynamic f:** Compensation of the dynamic frictions as a percentage of the drive rated current

- Set the maximum line speed reference, check that the minimum diameter has been set in **roll diameter** (if not carry out a **Diam reset** on the minimum diameter)
- Set temporarily the parameter **Static f**: with a value of 10-20%. The motor speed will increase reaching the speed **Base omega** (the converter in this phase has to overcome the current limit) .
- When the motor reaches its rated speed, set the parameter **Static f** with its previously tuned value. The speed will start decreasing.
- Increase gradually the parameter **Dynamic f** till the speed ends its decreasing phase and the motor rotates at a constant speed.
- Increase the speed by increasing temporarily the parameter **Static f**. Reset the parameter **Static f** with its right value. The motor must keep the reached speed.
- In a negative case, reset the parameter **Dynamic f** and repeat the tests till the required conditions have been reached.

**Static f Zero** By setting the parameter on “Enabled”, the friction compensation is completely inserted for all speed values. When it set as “Disabled”, the static friction compensation is completely inserted with Ref line speed = 1.5%.

**Int acc calc En** Enabling of the calculation for the coil acceleration.  
If enabled, this function calculates the angular acceleration inside the drive. In this case it is necessary to set just the value of **Time acc/dec min**. If disabled, the parameters **Line acc % - dec % - fast stop %** and **Time acc/dec min** have to be set and the digital inputs have to be supplied with the suitable indications.

**Time acc/dec min** Set the time in [s] corresponding to the lowest acceleration, deceleration and fast deceleration time.  
Set time acc/dec min =15sec (time required for a fast deceleration)

|                         |  |
|-------------------------|--|
| <b>Acc/dec filter</b>   | Filter in [ms] on the acceleration calculation inside the drive<br>Set =30 msec  |
| <b>Mat width</b>        | Width of the wound material as a percentage of the maximum width. Set =100%  |
| <b>Constant J comp</b>  | <p>Compensation of the fixed section (motor, reducer, core) as a percentage of the drive rated current. Increase the value till the motor can increase the speed following the line reference. During this phase the converter has always to be within the current limit.</p> <ul style="list-style-type: none"> <li>· Diameter calculation function disabled (enable the programmed digital input as <b>Dis diam calc</b>)</li> <li>· Operations to be carried out without material on the machine,</li> <li>· Install the empty winder (check that the parameter <b>Roll diameter</b>= min. diam). Check that the parameters <b>Constant J comp- Variable J comp</b>=0</li> <li>· Set the tension (<b>tension ref</b>)=0</li> <li>· Minimum jog function and line reference</li> <li>· Carry out some changes on the line reference.</li> <li>· Increase gradually the value of the parameter <b>Constant J comp</b> till the winder/unwinder is able to follow the line speed reference.</li> </ul> |
| <b>Variable J comp</b>  | <p>Torque compensation due to the wound material as a percentage of the drive rated current.</p> <ul style="list-style-type: none"> <li>· Operation to be carried out without material on the machine</li> <li>· Install a full coil on the winder (check that the parameter <b>Roll diameter</b>= max. diam ).</li> <li>· Follow the same procedure as the one carried out for the tuning of <b>Constant J comp</b></li> </ul>  |
| <b>Act var J comp</b>   | Monitor for the compensation of the variable section as a percentage of the drive rated current.   |
| <b>Act const J comp</b> | Monitor for the compensation of the fixed section as a percentage of the drive rated current.  |
| <b>Act comp</b>         | Monitor for the compensations (it sums up static, dynamic and inertial frictions) as a percentage of the drive rated current.  |

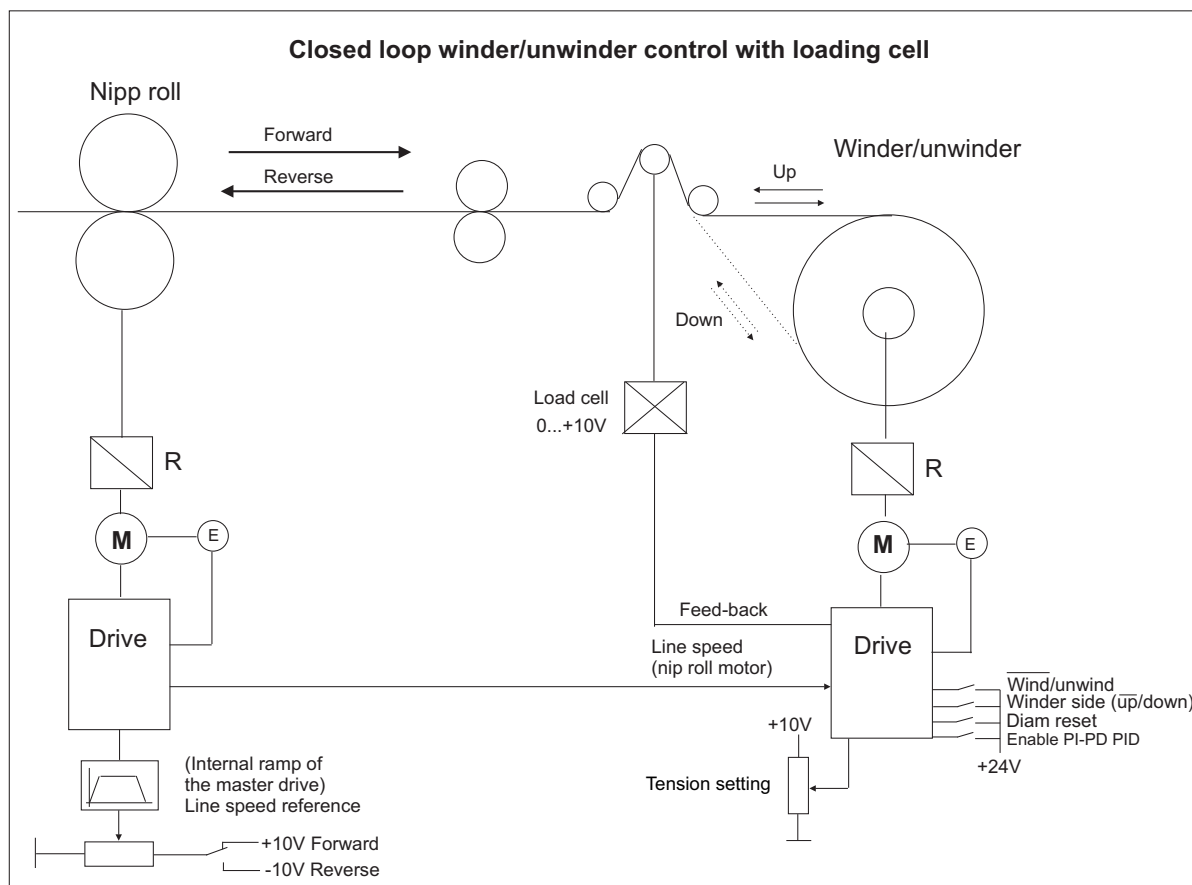

## Machine data

Maximum line speed=400m/min

Rated speed of the winder motor  $V_n=3000\text{rpm}$

Winder maximum diameter=0.7m

Winder minimum diameter=100mm

Motor-winder reduction ratio=0.5

Line speed reference 0-10V from nip roll motor.

Line acceleration/deceleration time =30sec.

Fast deceleration time fast/stop=15 sec.

Winder/unwinder selection via a digital input.

Winding side selection (up/down) via a digital input.

Tension setting via the analog input.

Set all the parameters as stated in the previous example. After testing the machine with an open loop material, carry out such settings for the tuning with a loading cell.

## ANALOG INPUT 3

**Pid feed back** Input of the loading cell;10V (20mA)=100%  
I/O CONFIG Menu

—————> Analog input

—————> Analog input 3 **Pid feed back**

**Closed loop En** Closing of the tension loop enabled (to be used with a loading cell).  
Set the parameter **Closed loop En**=enable

**Closed loop comp** Monitor for the present compensation on the output of the PID regulator used for the loop closing.

## DIGITAL INPUT

Programming of a digital input to enable the PID function

I/O CONFIG Menu

—————> digital input

—————> digital input 7:**enable PI-PD PID**

## Setting of Pid parameters

Set **Pid Source** as **PAD 1**.

**Pid source**=(8192+504)=8696

PARAMETERS

OPTION Menu

—————> PID

—————> Pid source

—————> Pid source=8695

Set **PAD 1** =10000

(Pad 1 is in the “Special function” menu)

Set **Pid source gain** =1

Set **PID target** as the parameter **Closed loop comp**

The parameter Closed loop comp has the decimal number 1208

In order to obtain the value to be entered add 8192 decimal (fixed offset )

**PID target**=8192+1208=9400

Set **Pid out scale**

**Pid out scale**=(max .value of closed loop comp)/max oPID output

**Pid out scale**=10000/10000=1

Set **PI top lim** and **Pi bottom lim** in order to have a 100% correction of its maximum value.

**PI top lim**=1

**Pi bottom lim**=-1

With this configuration the regulator output is positive and negative.

The gains of the several components have to be set experimentally with a loaded machine.

It is possible to start the tests with the values below :

set **PI P gain PID**=10%

set **PI I gain PID**=4%

set **PD P gain PID**=5%

set **PD D gain PID**=0%

**PD D filter PID**=20msec

Set **PI central vsel**=1

Set **PI central v 1**=0

With this configuration, when the switching ON/OFF of the parameters enabling the PID function is carried out, the regulator output starts from 0.

Before enabling the PID regulator and the loop closing it is necessary to check the matching between the set tension and the tension measured by the loading cell.

The loading cell has to be tuned in order to have an analog output =10V connected to the maximum tension on the required material.

With a loaded machine start the winder/unwinder by setting a tension of 50%.

Check the values of the parameters **Act tension ref** (0 , 100%, tension set in the Torque winder menu) and **Pid feedback** (0 , 10000, loading cell feedback in the PID menu). The two values must be the same.

If not, act on the parameter **Tension scale** till the two parameters reach the same values.

After this parameterization has been carried out, it is possible to start the tests with the material.

Improve the system stability via the different components of the blocks PI and PD PID.

## Provisions

In order to make the commissioning procedure easier and uniform, the system contains a clause referring to the speed and torque directions to be respected:

As a general rule the winder speed and the torque direction are considered positive with a upper winding side.

All the possible system configurations stated in the examples below refer to this clause.

**Note!** The polarity of the line speed reference is not important, because the system states the output reference polarity only according to the parameters **Wind/unwind** and **Winder side**.

### 1. Drive used as a winder – winding side = up

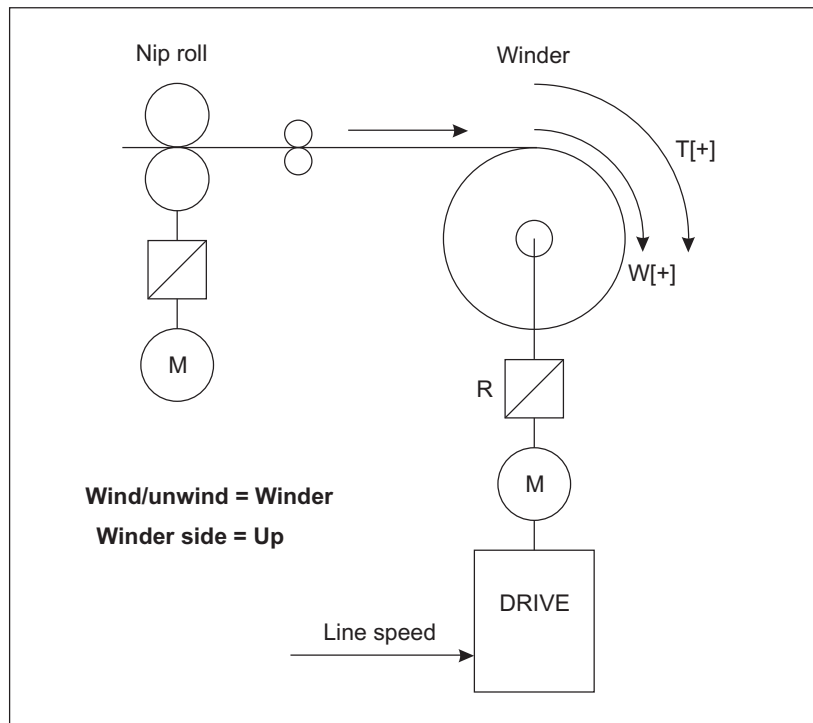

Figure 6.17.13: Drive used as a winder – winding side = up

If the speed demand function is used, the system creates a positive speed reference; it is therefore necessary to connect the motor so that, with this polarity, the coil winds the material starting from the upper side. The winding torque is positive.

## 2. Drive used as a winder – winding side = down

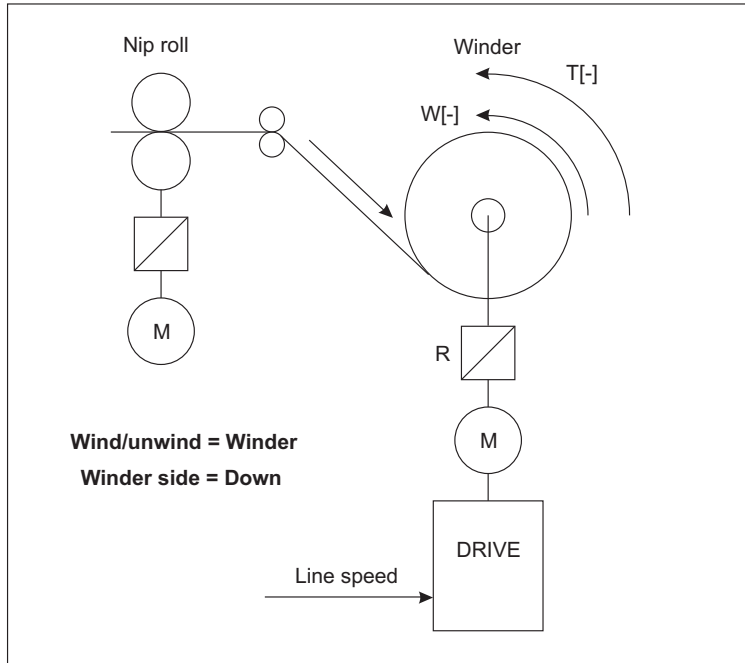

Figure 6.17.14: Drive used as a winder – winding side = down

If the speed demand function is used, the system creates a negative speed reference; it is therefore necessary to connect the motor so that, with this polarity, the coil winds the material starting from the lower side. The winding torque is negative.

## 3. Drive used as an unwinder – unwinding side = up

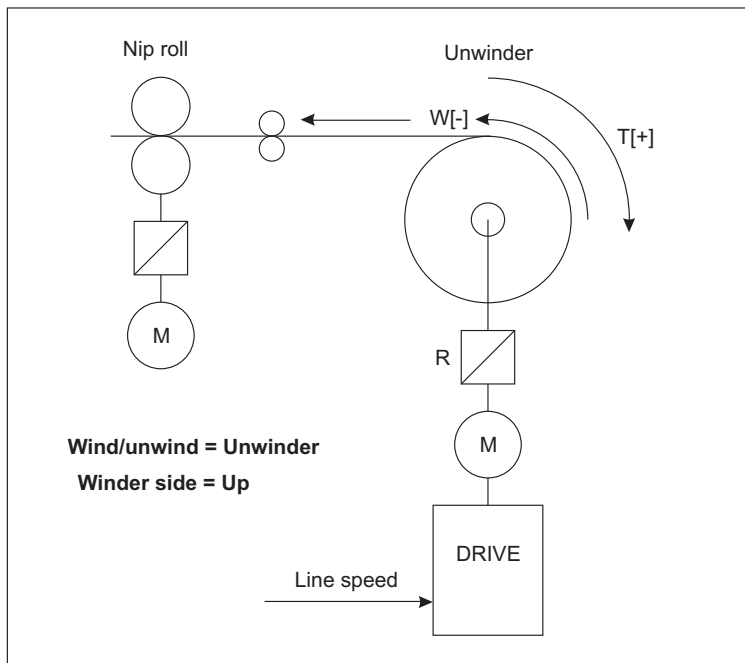

Figure 6.17.15: Drive used as an unwinder – unwinding side = up

If the speed demand function is used, the system creates a negative speed reference; it is therefore necessary to connect the motor so that, with this polarity, the coil unwinds the material starting from the upper side. The unwinding torque is positive.



#### 4. Drive used as an unwinder – unwinding side = down

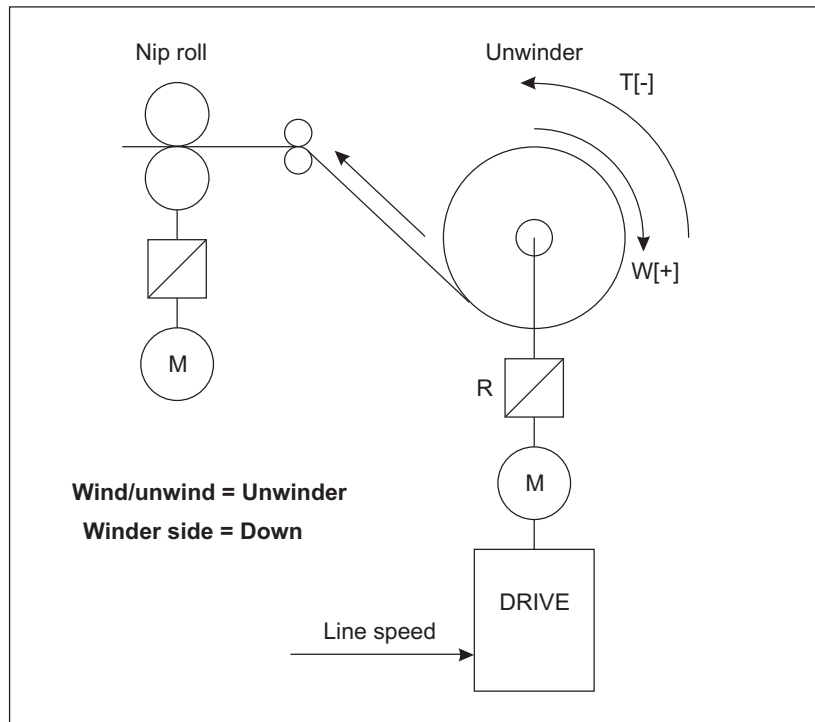
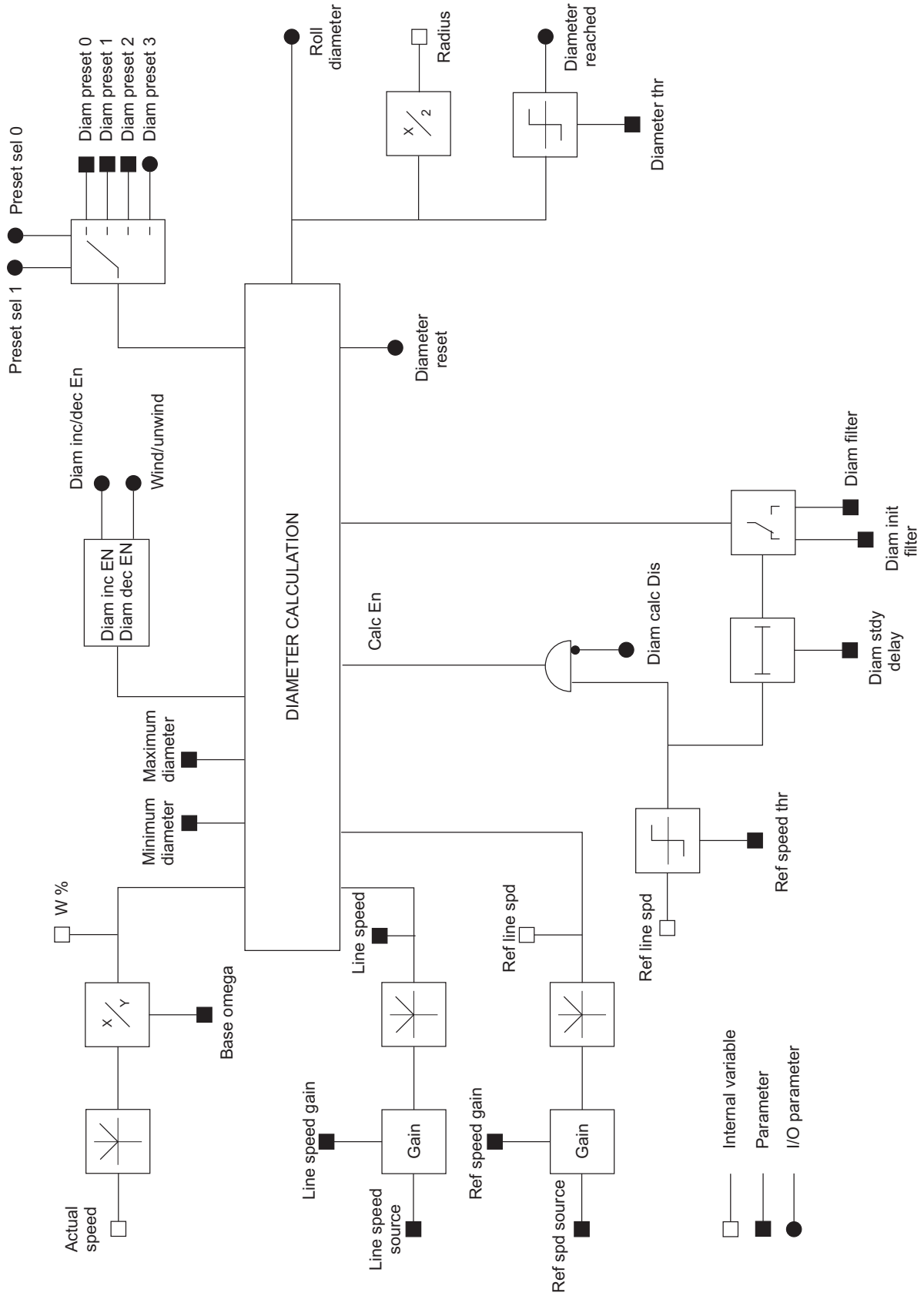
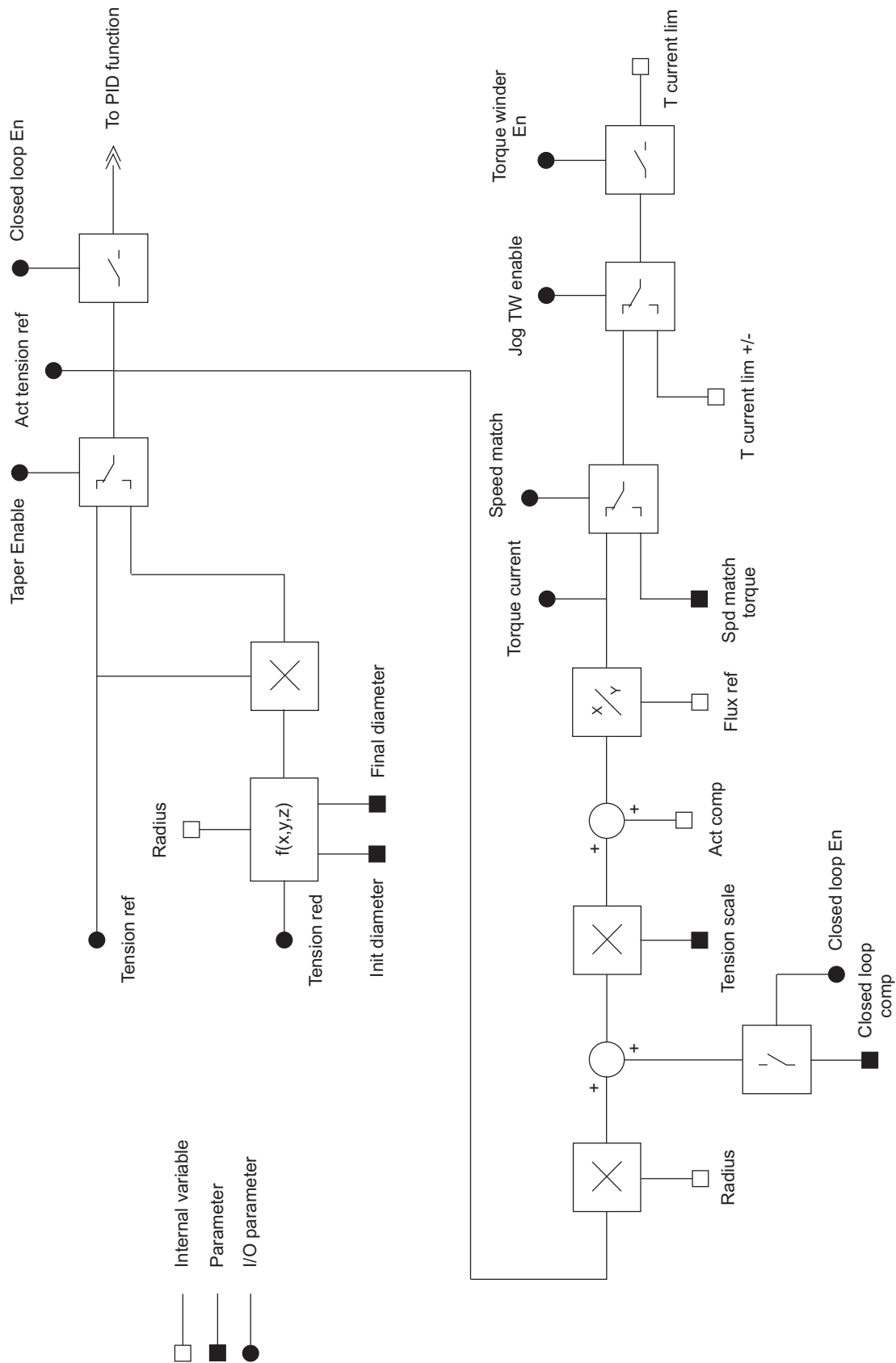

Figure 6.17.16: Drive used as an unwinder – unwinding side = down

If the speed demand function is used, the system creates a positive speed reference; it is therefore necessary to connect the motor so that, with this polarity, the coil unwinds the material starting from the lower side. The unwinding torque is negative.

### 6.17.7 Block diagram





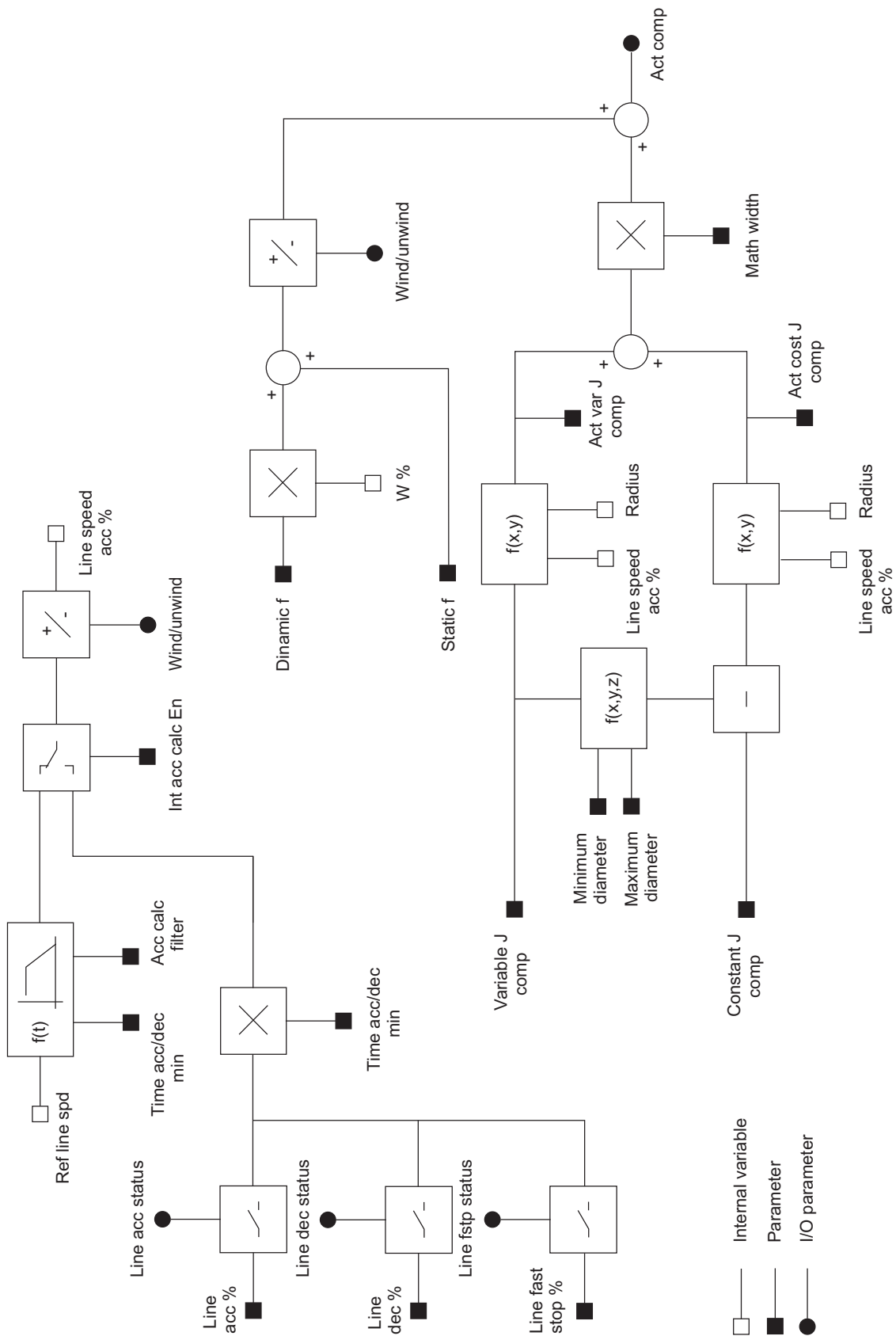

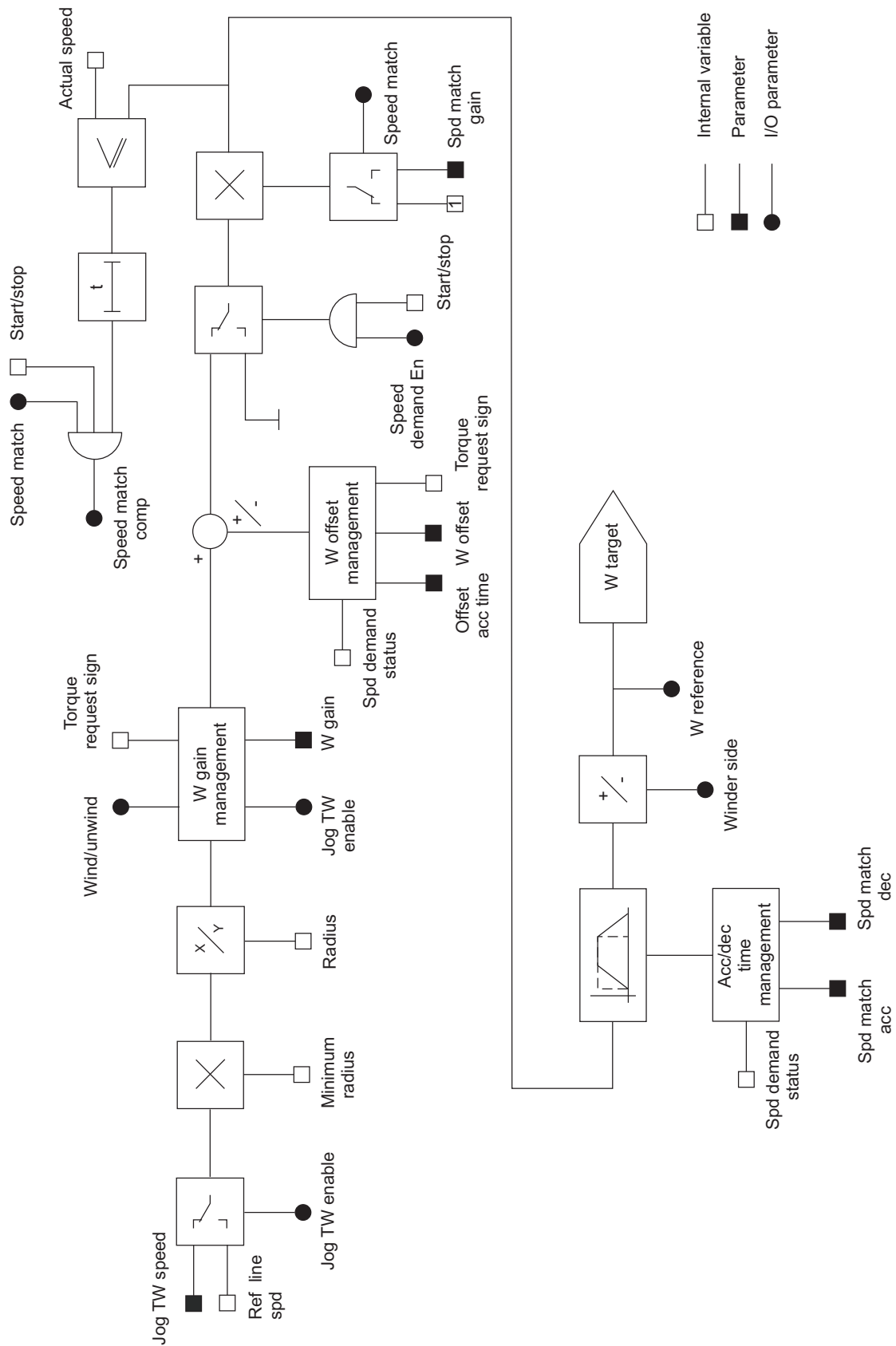

## 6.18 DRIVECOM

The DRIVECOM profile #21 “Power transmission,” defines the behavior of the drive if this is operated via the INTERBUS-S field bus. The DRIVECOM menu of the TPD32 converter provides functions that were defined in the above standards and which are required to operate a motor with the converter.

The TPD32 converters, however, have a considerably greater range of functions than is defined here. Apart from a few exceptions the parameters provided in this menu are described somewhere else in detail. We will therefore restrict this description to the Parameters function. See section 10, “Parameter list” and the above standard for further information on the parameters. When operating from a Bus, the parameters in the Drivecom group can also be accessed using the format and index specified in the above standard.

### 6.18.1 Control word, status word, malfunction code

| DRIVECOM |                  |
|----------|------------------|
| [57]     | Malfunction code |
| [55]     | Control word     |
| [56]     | Status word      |

| Parameter description | No. | Value |       |                  |                  | Standard Configuration |
|-----------------------|-----|-------|-------|------------------|------------------|------------------------|
|                       |     | min   | max   | Factory American | Factory European |                        |
| Malfunction code      | 57  |       |       |                  |                  |                        |
| Control word          | 55  | 0     | 65535 |                  |                  |                        |
| Status word           | 56  | 0     | 65535 |                  |                  |                        |

**Malfunction code** Malfunction code according to DRIVECOM specification (Mandatory functions)  
The code displayed indicates a particular failure. The meaning of the individual failures concerned is described in the section Programmable Alarms.

- 0000h **No failure**
- 1001h **Unknown**
- 2300h **Overcurrent**
- 3120h **Undervoltage**
- 3310h **Overvoltage**
- 3330h **Field loss**
- 4210h **Heatsink**
- 4310h **Overtemp motor**
- 5000h **Hardware**
- 5100h **Failure supply**
- 6110h **Dsp error**
- 6120h **Interrupt error**
- 7301h **Speed fbk loss**
- 7400h **Opt2**
- 7510h **Hw Opt 1 failure**
- 8110h **Bus loss**
- 9000h **External fault**
- 9009h **Enable seq err**

The code and the alarm are displayed in plain text in the event of a failure. The code is given in hexadecimal format.

**Control word** Control word according to DRIVECOM specification (Mandatory functions)

**Status word** Status word according to DRIVECOM specification (Mandatory functions).

## 6.18.2 Speed

| DRIVECOM |                       |
|----------|-----------------------|
| [44]     | Speed input var [FF]  |
| [115]    | Speed ref var [FF]    |
| [119]    | Act speed value [FF]  |
| [45]     | Speed base value [FF] |
| [46]     | Speed input perc [%]  |
| [116]    | Percent ref var [%]   |
| [120]    | Act percentage [%]    |

| Parameter description        | No. | Value  |        |                  |                  | Standard Configuration |
|------------------------------|-----|--------|--------|------------------|------------------|------------------------|
|                              |     | min    | max    | Factory American | Factory European |                        |
| <b>Speed input var [FF]</b>  | 44  | -2 P45 | +2 P45 | 0                | 0                | *                      |
| <b>Speed ref var [FF]</b>    | 115 | -32768 | +32767 | -                | -                | **                     |
| <b>Act speed value [FF]</b>  | 119 | -32768 | +32767 | -                | -                | ***                    |
| <b>Speed base value [FF]</b> | 45  | 1      | 16383  | 1500             | 1500             |                        |
| <b>Speed input perc [%]</b>  | 46  | -32768 | +32767 | 0                | 0                | *                      |
| <b>Percent ref var [%]</b>   | 116 | -32768 | +32767 |                  |                  | **                     |
| <b>Act percentage [%]</b>    | 120 | -32768 | +32767 |                  |                  | ***                    |

\* Factory set as Ramp ref and connected to analog input 1 (terminal 1 and 2). See reference values.

\*\* Factory set as Speed ref and connected to the ramp output. See reference values.

\*\*\* Factory set as Motor speed and connected to analog output 1. See BASIC MENU.

|                         |  |
|-------------------------|--|
| <b>Speed input var</b>  | 1st ramp reference value. The value to be entered is based on the factor function  |
| <b>Speed ref var</b>    | 1st speed reference value. The value to be entered is based on the factor function   |
| <b>Act speed value</b>  | Speed actual value in the unit specified in the factor function.   |
| <b>Speed base value</b> | The <b>Speed base value</b> is given in the unit specified in the factor function. It is the base value for all speed values given as a percentage (reference values, adaptive speed regulation ...). A change in this parameter is only possible when the drive is disabled. ( <b>Enable drive</b> = Disabled). |
| <b>Speed input perc</b> | 1st ramp reference value. Defined as a percentage of the <b>Speed base value</b>   |
| <b>Percent ref var</b>  | 1st speed reference value. Defined as a percentage of the <b>Speed base value</b>  |
| <b>Act percentage</b>   | Speed actual value as a percentage of the <b>Speed base value</b>  |

### 6.18.3 Speed limitation

| DRIVECOM             |                       |
|----------------------|-----------------------|
| <b>Speed amount</b>  |                       |
| [1]                  | Speed min amount [FF] |
| [2]                  | Speed max amount [FF] |
| <b>Speed min/max</b> |                       |
| [5]                  | Speed min pos [FF]    |
| [3]                  | Speed max pos [FF]    |
| [6]                  | Speed min neg [FF]    |
| [4]                  | Speed max neg [FF]    |

| Parameter description        | No. | Value |            |                  |                  | Standard Configuration |
|------------------------------|-----|-------|------------|------------------|------------------|------------------------|
|                              |     | min   | max        | Factory American | Factory European |                        |
| <b>Speed min amount [FF]</b> | 1   | 0     | $2^{32}-1$ | 0                | 0                | -                      |
| <b>Speed max amount [FF]</b> | 2   | 0     | $2^{32}-1$ | 5000             | 5000             | -                      |
| <b>Speed min pos [FF]</b>    | 5   | 0     | $2^{32}-1$ | 0                | 0                | -                      |
| <b>Speed max pos [FF]</b>    | 3   | 0     | $2^{32}-1$ | 5000             | 5000             | -                      |
| <b>Speed min neg [FF]</b>    | 6   | 0     | $2^{32}-1$ | 0                | 0                | -                      |
| <b>Speed max neg [FF]</b>    | 4   | 0     | $2^{32}-1$ | 5000             | 5000             | -                      |

- Speed min amount** Defines the minimum speed for both rotation directions (with TPD32...4B...).  
A lower value than the defined value is not possible, regardless of the reference value set. It has an effect on the input of the ramp. If the **Speed min amount** parameter is changed, the **Speed min pos** and **Speed min neg** parameters are set to the same value. If one of these two parameters is changed later, the last change is valid. The current value for positive rotation (clockwise) is shown in the display of the keypad. The value to be entered is based on the factor function.
- Speed max amount** Defines the maximum speed for both rotation directions (with TPD32...4B...).  
The function has an effect on the input of the speed regulator and therefore takes into account the reference value that comes from the ramp as well as the directly defined values (see Figure 6.4.2.1). If the Speed max amount is changed, the **Speed max pos** and **Speed max neg** parameters are set to the same value. If one of these two parameters is changed later, the last change is valid. The current value for positive rotation (clockwise) is shown in the display of the keypad. The value to be entered is based on the factor function.
- Speed min pos** Defines the minimum speed for the clockwise rotation of the motor. A lower value than the defined value is not possible, regardless of the reference value. The function has an effect on the input of the ramp (see Figure 6.4.1.1). The value to be entered is based on the factor function.
- Speed max pos** Defines the maximum speed for the clockwise rotation of the motor. The function has an effect on the input of the speed regulator, and therefore takes into consideration the reference value that comes from the ramp as well as those that are entered directly (see Figure 6.4.2.1). The value to be entered is based on the factor function.



|                      |  |
|----------------------|--|
| <b>Speed min neg</b> | Defines the minimum speed for the anti-clockwise rotation of the motor (with TPD32...4B...). A lower value than the defined value is not possible, regardless of the reference value. The function has an effect on the input of the ramp (see Figure 6.4.1.1). The value to be entered is based on the factor function.   |
| <b>Speed max neg</b> | Defines the maximum speed for the anti-clockwise rotation of the motor (with TPD32...4B...). The function has an effect on the input of the speed regulator, and therefore takes into consideration the reference value that comes from the ramp as well as the those that are entered directly (see Figure 6.4.2.1). The value to be entered is based on the factor function. |

## 6.18.4 Acceleration / Deceleration

| DRIVECOM            |                       |  |
|---------------------|-----------------------|--|
| <b>Acceleration</b> |                       |  |
| [21]                | Acc delta speed [FF]  |  |
| [22]                | Acc delta time [s]    |  |
| <b>Deceleration</b> |                       |  |
| [29]                | Dec delta speed [FF]  |  |
| [30]                | Dec delta time [s]    |  |
| <b>Quick stop</b>   |                       |  |
| [37]                | QStp delta speed [FF] |  |
| [38]                | QStp delta time [s]   |  |

| Parameter description                             | No. | Value |            |                  |                  | Standard Configuration |
|---|-----|-------|------------|------------------|------------------|------------------------|
|   |     | min   | max        | Factory American | Factory European |                        |
| Acc delta speed [FF]                              | 21  | 0     | $2^{32}-1$ | 100              | 100              |                        |
| Acc delta time [s]                                | 22  | 0     | 65535      | 1                | 1                |                        |
| Dec delta speed [FF]                              | 29  | 0     | $2^{32}-1$ | 100              | 100              |                        |
| Dec delta time [s]                                | 30  | 0     | 65535      | 1                | 1                |                        |
| QStp delta speed [FF]                             | 37  | 0     | $2^{32}-1$ | 1000             | 1000             |                        |
| QStp delta time [s]                               | 38  | 0     | 65535      | 1                | 1                |                        |
| Quick stop<br>Quick stop (0)<br>No Quick stop (1) | 343 | 0     | 1          | No Quick stop    | No Quick stop    |                        |

- Acc delta speed** Has the same unit as the ramp reference value and is based on the factor function.
- Acc delta time** Is defined in seconds. The ramp output follows the reference value directly if “0 s” is entered.
- Dec delta speed** Has the same unit as the ramp reference value and is based on the factor function.
- Dec delta time** Is defined in seconds. If “0 s” is entered, the ramp output follows the reference value directly.
- Qstp delta speed** Has the same unit as the ramp reference value and is based on the factor function.

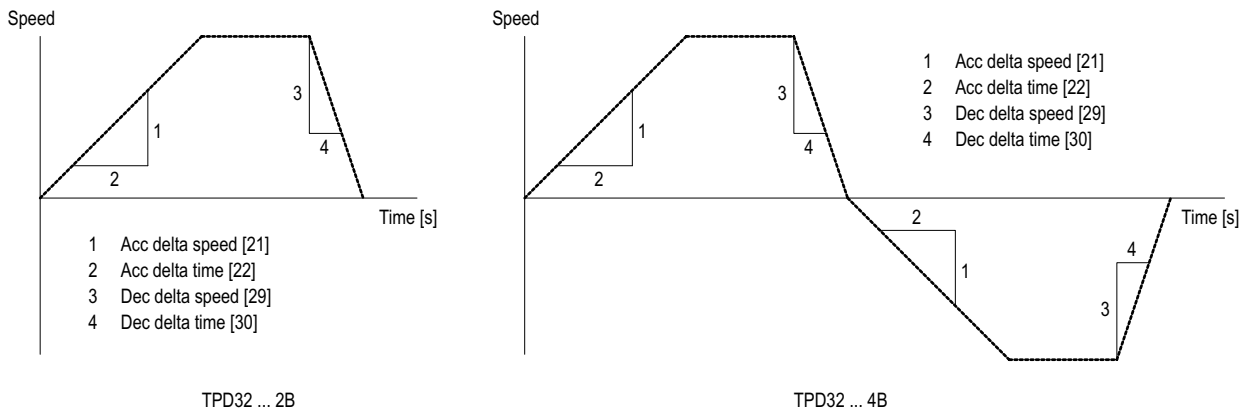

Figure 6.17.4.1: Acceleration and deceleration

**Qstp delta time** Is defined in seconds. If “0 s” is entered, the ramp output follows the reference value directly.

**Quick stop** Activates the Quick stop ramp to stop the Drive.

The acceleration of the drive is defined as a quotient of the **Acc delta speed** and **Acc delta time** parameters. It is the same for both rotation directions of the motor.

The deceleration of the drive is defined as a quotient of the **Dec delta speed** and **Dec delta time** parameters. It is the same for both rotation directions of the motor.

The Quick stop function provides a second deceleration ramp for braking the drive to halt in the event of an emergency. The deceleration of the drive using the Quick stop function is defined as a quotient of the Qstp delta speed and Qstp delta time. It is the same for both rotation directions of the motor. This function is only available via the serial interface or BUS.

## 6.18.5 Factor function

| DRIVECOM |                        |                |
|----------|------------------------|----------------|
|          | <b>Face value fact</b> |                |
|          | [54]                   | Face value num |
|          | [53]                   | Face value den |
|          | <b>Dimension fact</b>  |                |
|          | [50]                   | Dim factor num |
|          | [51]                   | Dim factor den |
| [52]     | Dim factor text        |                |

The factor function contains two factors, the Dimension factor and Face value factor. They are both expressed as fraction numbers.

The dimension factor enables the drive speed to be defined in a machine-related dimension, e.g. kg/h or m/min. Further information and examples are given in the section on the Configuration menu.

| Parameter description  | No. | Value |                    |                  |                  | Standard Configuration |
|------------------------|-----|-------|--------------------|------------------|------------------|------------------------|
|                        |     | min   | max                | Factory American | Factory European |                        |
| <b>Face value num</b>  | 54  | 1     | 32767              | 1                | 1                |                        |
| <b>Face value den</b>  | 53  | 1     | 32767              | 1                | 1                |                        |
| <b>Dim factor num</b>  | 50  | 1     | 65535              | 1                | 1                |                        |
| <b>Dim factor den</b>  | 51  | 1     | 2 <sup>31</sup> -1 | 1                | 1                |                        |
| <b>Dim factor text</b> | 52  |       |                    | rpm              | rpm              |                        |

**Dim factor num** Numerator of the dimension factor

**Dim factor den** Denominator of the dimension factor

**Dim factor text** Unit of the dimension factor. This text is shown in the display of the keypad when the reference value is shown.

Possible characters: / % & + , - . 0..9 : < = > ? A...Z [ ] a...z

**Face value num** Numerator of the reference value factor.

**Face value den** Denominator of the reference value factor.

See example in section 6.11.7, “Dimension factor, Face value factor”, on how to make the calculation.

## 6.19 SERVICE

The SERVICE menu is only accessible for the service personnel of the manufacturer.

# 7- MAINTENANCE

## 7.1 CARE

The TPD32 converters must be installed according to the relevant installation regulations. They do not require any particular care. They should not be cleaned with a wet or moist cloth. The power supply must be switched off before cleaning.

## 7.2 SERVICE

The screws of all terminals on the device should be tightened two weeks after initial commissioning. This should be repeated once a year.

## 7.3 REPAIRS

Repairs on the device should be made by your supplier's trained personnel.

If you carry out a repair of your own, observe the following points:

- When ordering spare parts, do not only state the device type but also the device number (nameplate). It is also useful to state the type of regulator card and the software version of the operating system
- When exchanging cards, ensure that the positions of switches and jumpers are observed. This particularly applies to switch SW15 on the regulator card. This sets the rated current of the converter.

**Note!** The manufacturer does not accept any liability for any device parts that are destroyed due to the incorrect position of switch SW15.

## 7.4 CUSTOMER SERVICE

For customer service, please contact your Gefran office.



# 8 - TROUBLESHOOTING

The following describes possible faults and their causes.

## **Failure alarms in the keypad display**

### **FAILURE ALARM**

### **POSSIBLE CAUSES**

#### **Bus loss**

Failure in the Bus connection (only with interface Bus option card)

Check the Bus connection

EMC compatibility problems

Try a RESET. If you are still unsuccessful: probable internal fault. Contact your sales office.

#### **Brake fault**

Error in the brake opening or closing sequence after the **Brake control** has been enabled.

Refer to chapter **6.14.8** and check that wiring, parameters and sequences of signals are correct.

#### **Delta frequency**

Excessive difference between the frequency of the three-phase power supply input and the value measured the instant this is guaranteed.

**Delta freq thres** parameter set too low.

Check that the frequency of the three-phase power supply remains constant or in any case within the threshold limit throughout drive operation.

#### **Drive I2t ovrlld**

Excessive drive overload.

Wait until the accumulator (**Drive I2t accum**) is zeroed before resetting the alarm and then enable the drive. No data can be configured for this alarm; however, reference should be made to chapter **6.14.6** for further information about calculating thresholds.

#### **Enable seq err**

Drive is powered up or Reset with Enable input connected to 24 V (picked up) and the Drive is configured to run from the terminals. Refer to CONFIGURATION/Main commands.

#### **External fault**

External failure, reported on terminal 15

If the "External fault" message is not used: connection missing between terminals 16 and 18 (reference point) and/or 15 and 19.

If the "External fault" message is used:

The signal on terminal 15 is missing (15...30V to terminal 16).  
With external voltage supply: reference points must be connected with each other!

## FAILURE ALARM

## POSSIBLE CAUSES

### Failure supply

Fault in voltage supply = the voltages are below the permitted value

**CAUTION:** switch off voltage before removing terminal strips.

In most cases the cause is in the external wiring. Pull out the plug-in terminal strips of the regulator card and enter the Reset command. If no other failures are reported, check your wiring for a short-circuit, in some cases with the cable shielding.

If this has not rectified the fault: remove the terminal strips of the I/O option card (if present) and try RESET once more.

If you are still unsuccessful: probably an internal fault. Contact your sales office.

### Field loss

Too low field current

The field regulation is blocked

The conductors in the field circuit are interrupted

Field fuses are active

### Heatsink

Heatsink temperature too high

Ambient temperature too high

Failure of device fan [with devices > 88 A (American), 110 A (European)]

Dirty heatsink.

### Hw opt1 failure

Failure on the option card 1

Try a RESET. If you are still unsuccessful: probable internal fault. Contact your sales office.

### Motor I2t ovrlld

Excessive motor overload.

Refer to chapters **6.14.6** and **6.11.7 (Motor I2t ovrlld alarm)** and check the exactness of the data that have been entered. If these are correct, wait until the accumulator (**Motor I2t accum**) is zeroed before resetting the alarm and then enable the drive.

### Opt2 failure

Failure on the option card 2

Try a RESET. If you are still unsuccessful: probable internal fault. Contact your sales office.

### Overcurrent

Overcurrent in the motor circuit

Short-circuit or ground fault at the output of the converter

Current regulator optimized incorrectly

**Overcurrent thr** parameter too low



## FAILURE ALARM

## POSSIBLE CAUSES

### Overspeed

Excessive motor speed in the feedback circuit.

**Overspeed thr** parameter set too low.

Check that the **Speed fbk sel** parameter has been selected consistently with the feedback used (Encoder 1, Encoder 2, Tacho, Armature).

If an encoder or tacho generator feedback circuit is used, check the relative wiring.

### Overtemp Motor

Motor overtemperature (signaled by the thermistor to the terminals 78/79)

The motor is not provided with a thermistor: no jumper between the terminals 78 and 79

Cable between thermistor connection on motor and terminals 78 and 79 interrupted.

Overheating of motor:

Load cycle too extreme

Ambient temperature at site of motor too high

Motor has an external fan: fan failed

Motor does not have an external fan: too large a load at low speeds. The cooling effect of the fan on the motor shaft is too low for this load cycle. Change cycle or fit external fan.

### Overvoltage

Overvoltage of the armature circuit

**Max out voltage** parameter set too low.

The drive does not operate with a field weakening, even though the set speed can be reached only with a field weakening. Check the **Flux reg mode** parameter.

### Speed fbk loss

No speed feedback signal

The conductors of the feedback signal are interrupted

One or several encoder channels are missing (conductor interruption, no encoder power supply)

### Undervoltage

Undervoltage on the power circuit

**Undervolt thr** parameter set incorrectly (possibly 400 V set, although the device is run on 230 V). Remedy: set parameter correctly and then acknowledge the failure via RESET.

The incoming voltage to the terminals U/V/W of the device is too low due to:

too low an AC input voltage

poor cable connections (e.g. terminals on contactor, choke, filter ... not properly fixed). Remedy: check connections.

Intervention of the line fuses

AC input voltage dips, or high distortion of the supply voltage

The converter has been enabled when the supply voltage is not present.

## Other faults

### FAILURE

### POSSIBLE CAUSES

#### The motor is not turning

Failure alarm is displayed: see table above

Once the error has been rectified give the RESET command

Keypad display is dark: voltage supply to terminals U2/V2 missing or internal fuse blown or missing

Enable and/or start command missing

Converter not accepting commands: incorrect or wrongly selected operating mode

Protective device of the power supply has tripped: protective device incorrectly sized or fault on the thyristor bridge

The analog input used for the reference value was not assigned or assigned differently

Negative reference with TPD32...2B. The reference for the biquadrant converters must always be positive!

#### The motor is turning in a wrong way

Wrong polarity of the reference sign (with TPD32...4B)

The motor is connected in a wrong way.

ATTENTION: when the motor turns in a wrong way but the rotation direction can be changed, remember to change both the armature or field conductors and the two encoder connections (A+ with A- or B+ with B-). Using a tachometer change the conductor polarity.

#### The motor does not reach the rated speed

Drive is within speed limitation. Remedy: check **Speed max amount**, **Speed max pos** and **Speed max neg** parameters

Drive working at current limit (LED  $I_{Limit}$  lit) Possible causes:

Motor overloaded

Converter sized too small

Flux reduction selected via **Torque reduct**

The entered value for the number of encoder pulses is too high. Remedy: check the parameters concerned (**Encoder 1 pulses** when using plug connector XE1 or **Encoder 2 pulses** with plug connector XE2) and set correct value.

Wrong adaptation of the tachometer voltage. Check the voltage field choice (jumpers to the terminals A/B/C). Check the **Tacho scale** parameter.

A correction value reduces the main reference value. Remedy: check the configuration

The factor function is set incorrectly.

## FAILURE

## POSSIBLE CAUSES

### The motor reaches the maximum speed immediately

Reference value set via terminals: Check whether the value varies from min. to max. value.  
Potentiometer used for reference value setting: is there a 0V connection present?

Encoder/tachometer not connected, or incorrectly connected or not supplied:

Preset the **Actual spd** parameter in the DRIVE STATUS menu.

With the regulator disabled turn the motor clockwise (viewed from the front of the shaft). The value indicated must be positive.

If the indicated value does not change or if inexplicable values are shown, check the power supply and the cabling of the encoder/tachometer.

If the indicated value is negative, reverse the encoder connections. Exchange channel A+ and A- or B+ and B-. Using a tachometer change the conductor polarity.

### The motor accelerates too slowly

Ramp set incorrectly

Motor running at max. current

Motor overloaded

Converter too small

### The motor decelerates too slowly

Ramp values and times incorrectly set

Braking current too low

With twoquadrant drives: moment of inertia too high.

### The motor turns slowly even though the reference value = zero

Minimum speed selected

Interference due to unused analog input. Remedy: set unused analog inputs to OFF

Disconnect reference value on used analog input

If drive now stands still, the effect is due to the cable resistance of the 0V cable.

If the drive is still turning: check if the speed reference is zero.

If it is not zero set **Offset input xx** parameter so that the drive stands still. If it is zero set Spd offset parameter.

### The motor thermic is active

Overloaded motor

Motor thermic protection relay incorrectly scaled

### The motor is not supplying the max torque and the max power

Drive working at current limit

Check whether the value for **Full load curr** in the CONFIGURATION menu is set correctly

Check the value for the current limitation

## FAILURE

## POSSIBLE CAUSES

### The speed during acceleration with max. current is not linear

Reduce the **Speed I** and **Speed P** proportionally. If this does not lead to an improvement, optimize the regulator (see chapter 5.3.6).

### Speed oscillating

Check **Speed P** and **Speed I** parameter

If the operating point is in the field weak range, check the **Fld reg P gain** and **Fld reg I gain** parameters and eventually **Voltage P** and **Voltage I** parameters.

Remedy: Optimize the regulator as previously described

### Drive not reacting to adaptive speed regulation

Adaptive speed regulation not enabled. **Enable spd adap** = Enabled

### Motor potentiometer function not executed

Function not enabled. **Enable motor pot** = Enabled

With operation via the terminal strip: **Motor pot up** and/or **Motor pot down** were not assigned to a digital input

### Jog operation not possible

A start command is still present

Function not enabled. **Enable jog** = Enabled

With operation via terminal strip: **Jog +** and/or **Jog -** were not assigned to a digital input.

### Internal speed reference values not carried out

Function not enabled. **Enab multi spd** = Enabled

With operation via terminal strip: **Speed sel 0**, **Speed sel 1** and **Speed sel 2** were not assigned to a digital input.

### Multi-Ramp function not reacting

Function not enabled. **Enab multi rmp** = Enabled

With operation via terminal strip: **Ramp sel 0** and **Ramp sel 1** were not assigned to a digital input

### Overload not possible

Function not enabled. **Enable overload** = Enabled

### The Current regulator selftune procedure never finishes and continues over and over again.

Because of the motor inductance value, the routine is executing an endless loop. The inductance value is cycling between two values without an evolution of the algorithm.

Solution procedure:

- 1) verify the two displayed inductance values
  - 2) insert the average value as motor inductance during the autotuning.
- If the procedure does not end, repeat step 1) and 2).

# 9 - BLOCK DIAGRAM

## 9.1 CONTROL BLOCK DIAGRAMS

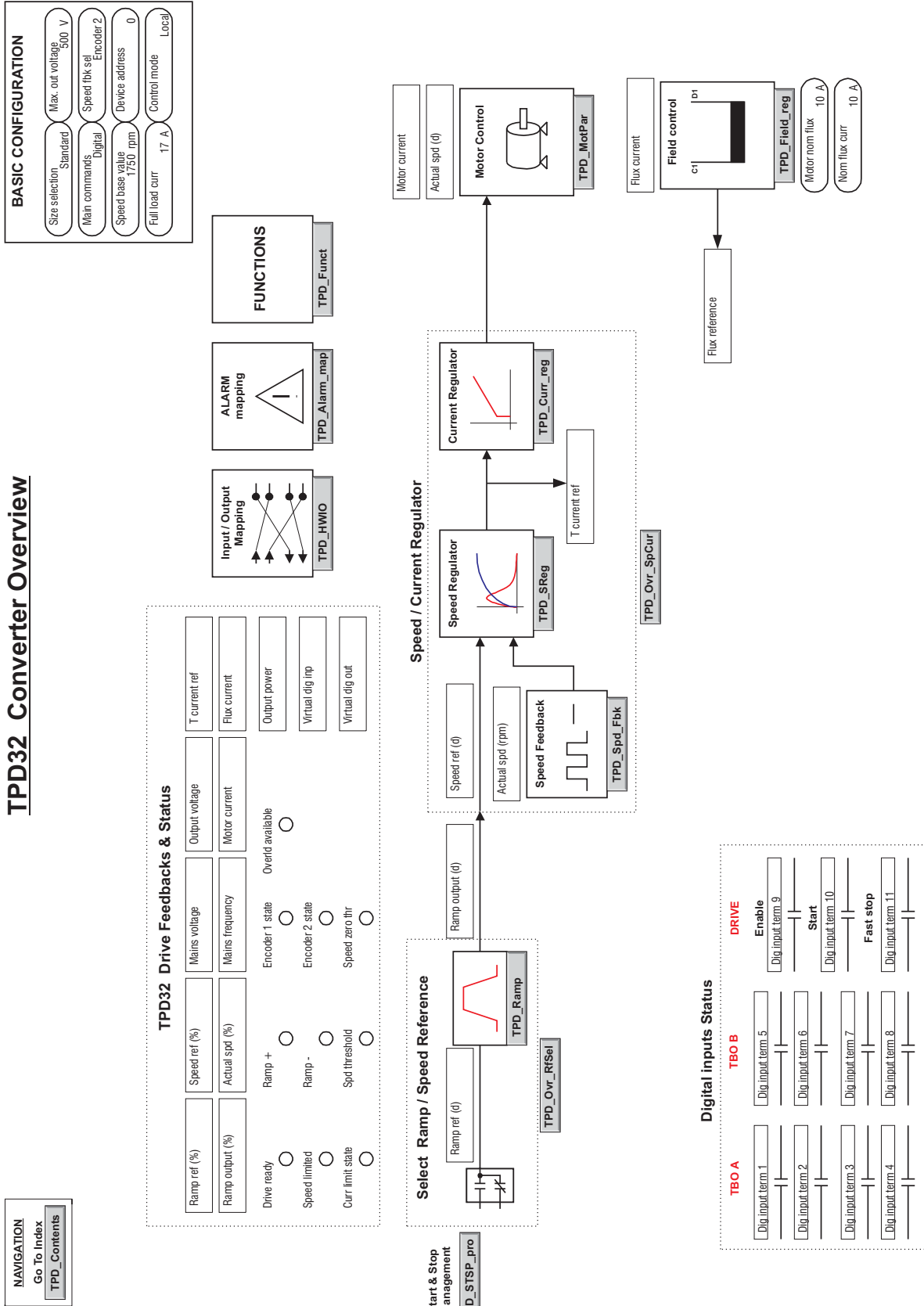

TPD\_Ovw.vsd

NAVIGATION

Overview TPD\_Ovw Analog I/O TPD\_HWIOAN

Digital Inputs

TBO pos. A

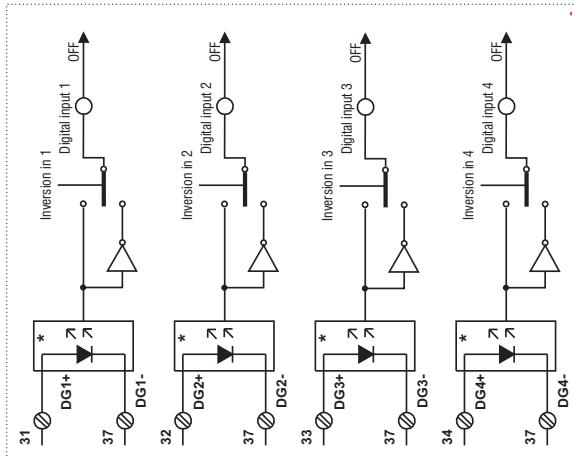

TBO card pos. B (option)

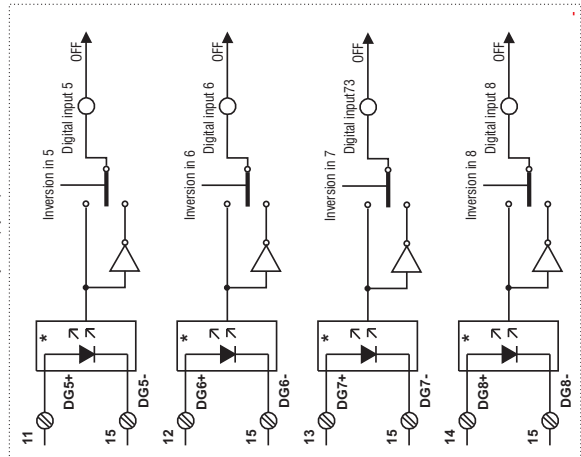

Digital Inputs/Outputs & Mapping Standard and TBO card

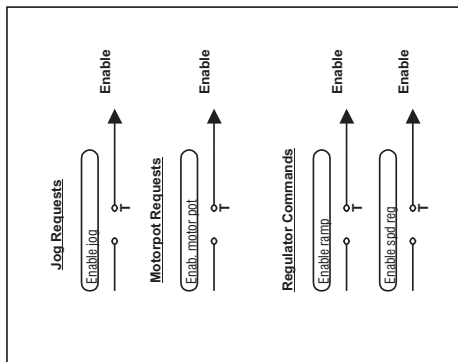

Digital Outputs

TBO pos. A

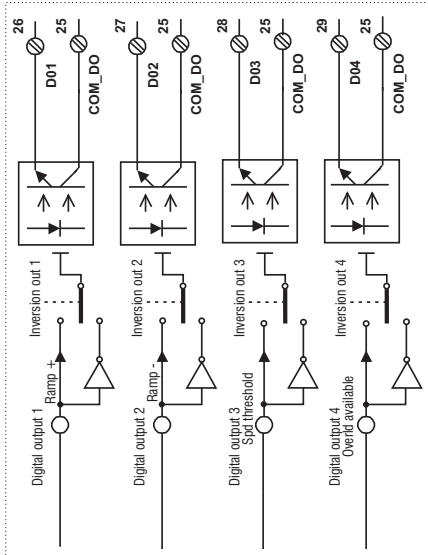

TBO card pos. B (option)

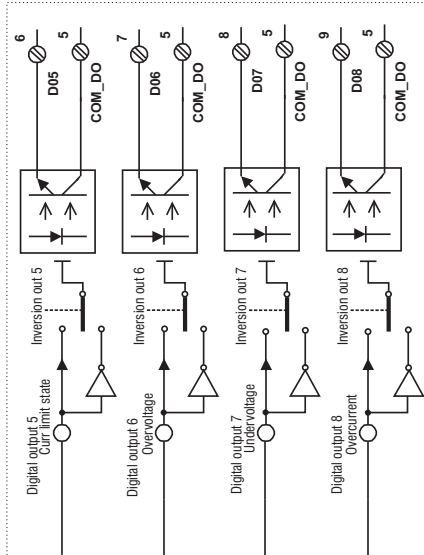

Drive Relay Output

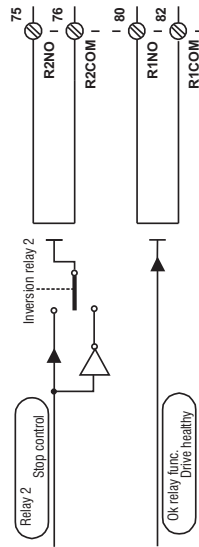

# Analog Inputs/Outputs & Mapping

NAVIGATION

Overview

TPD\_Ovw

Digital I/O

TPD\_HWIO

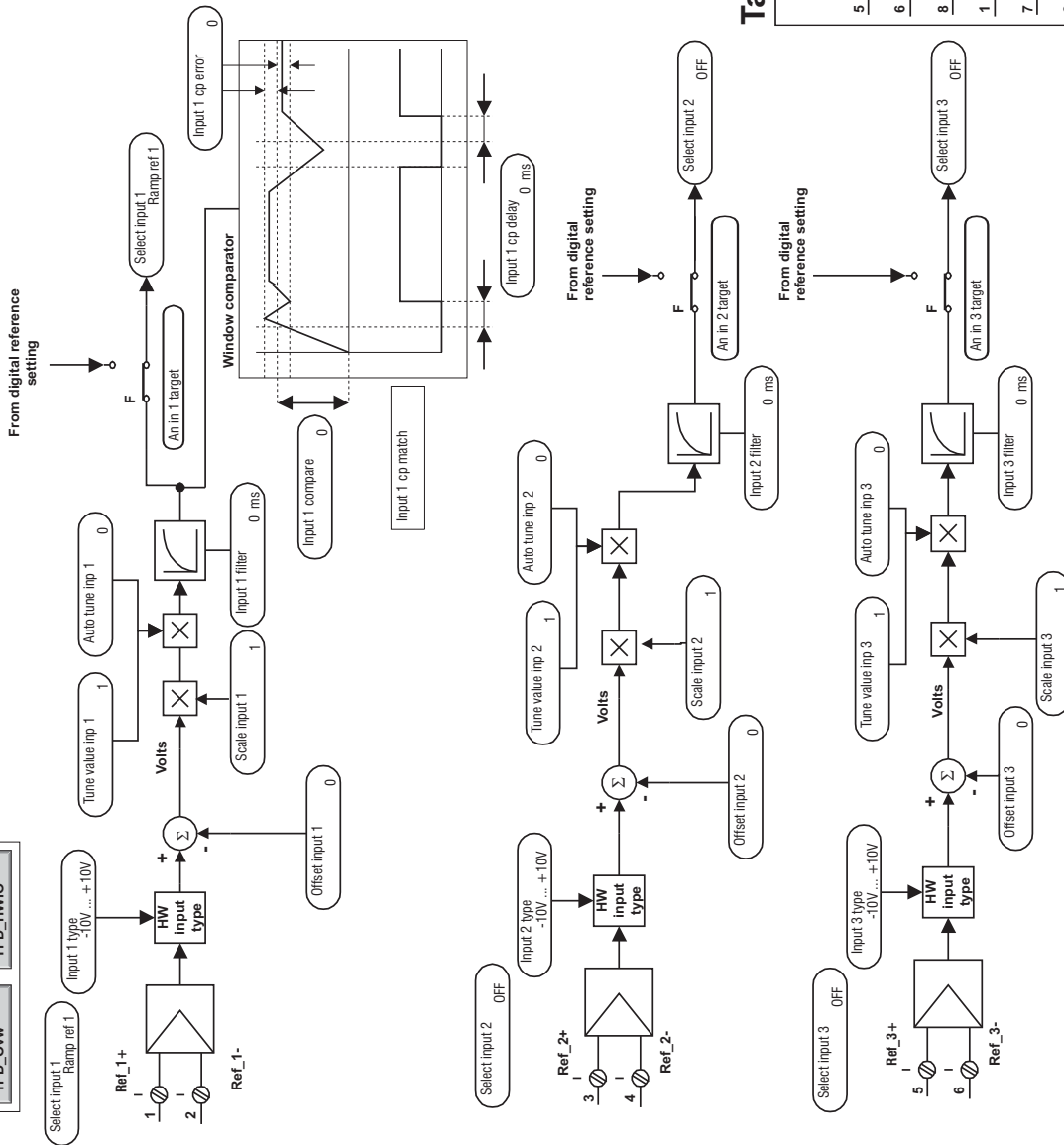

## Analog Outputs

TBO pos. A

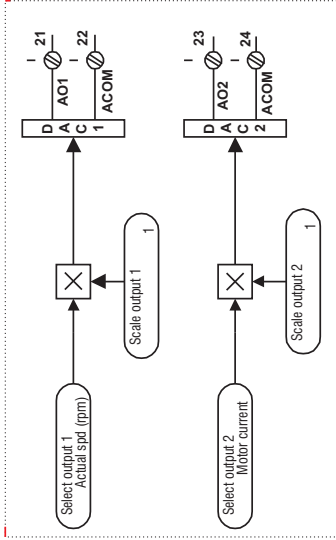

## TBO card pos. B (option)

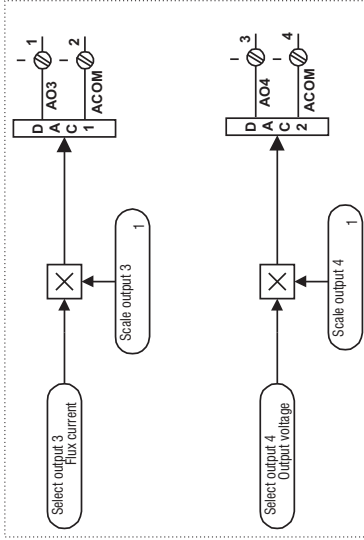

## Tach follower

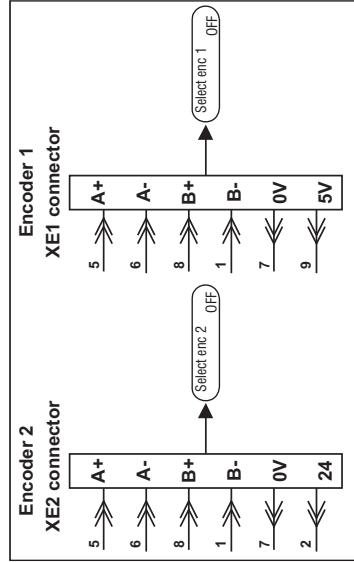

TPD\_HWIOAN.vsd

# Speed Reference Generation

NAVIGATION  
 Back to Overview  
 TPD\_Ovr

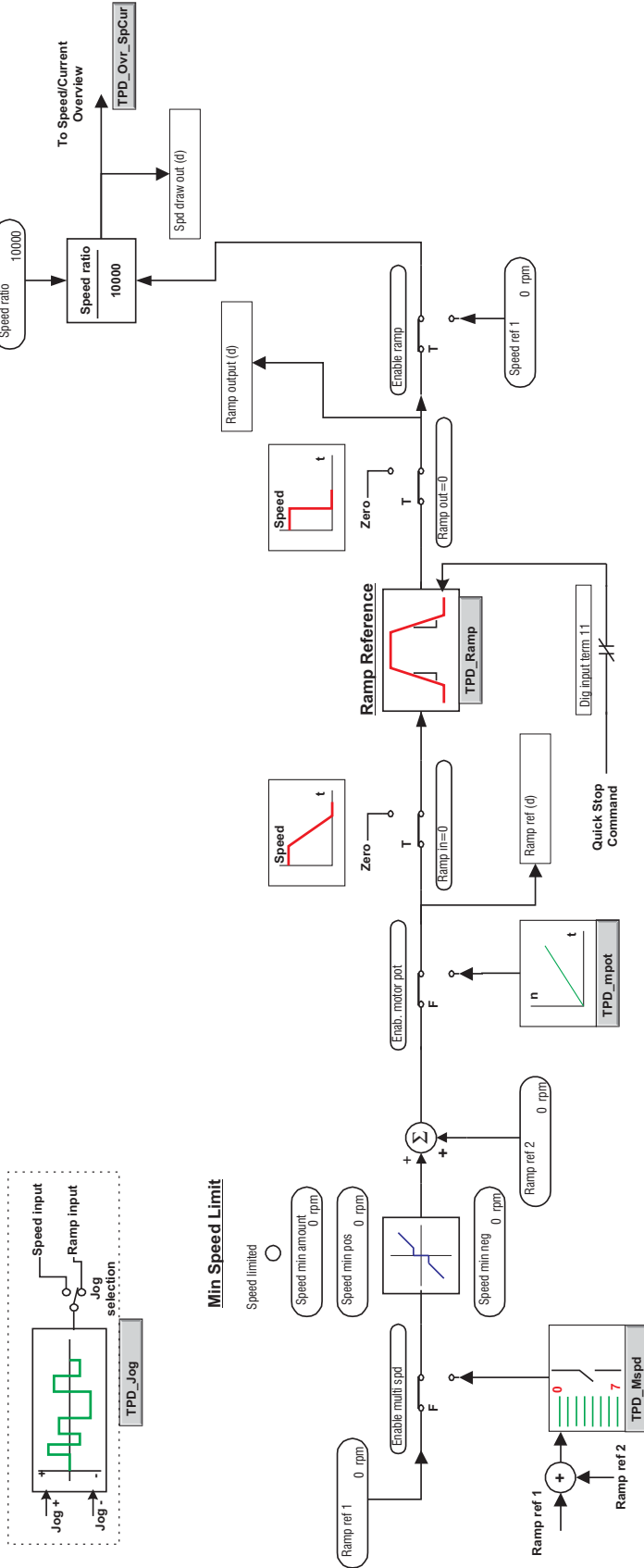

TPD\_Ovr\_RSel.vsd



# Ramp reference Block

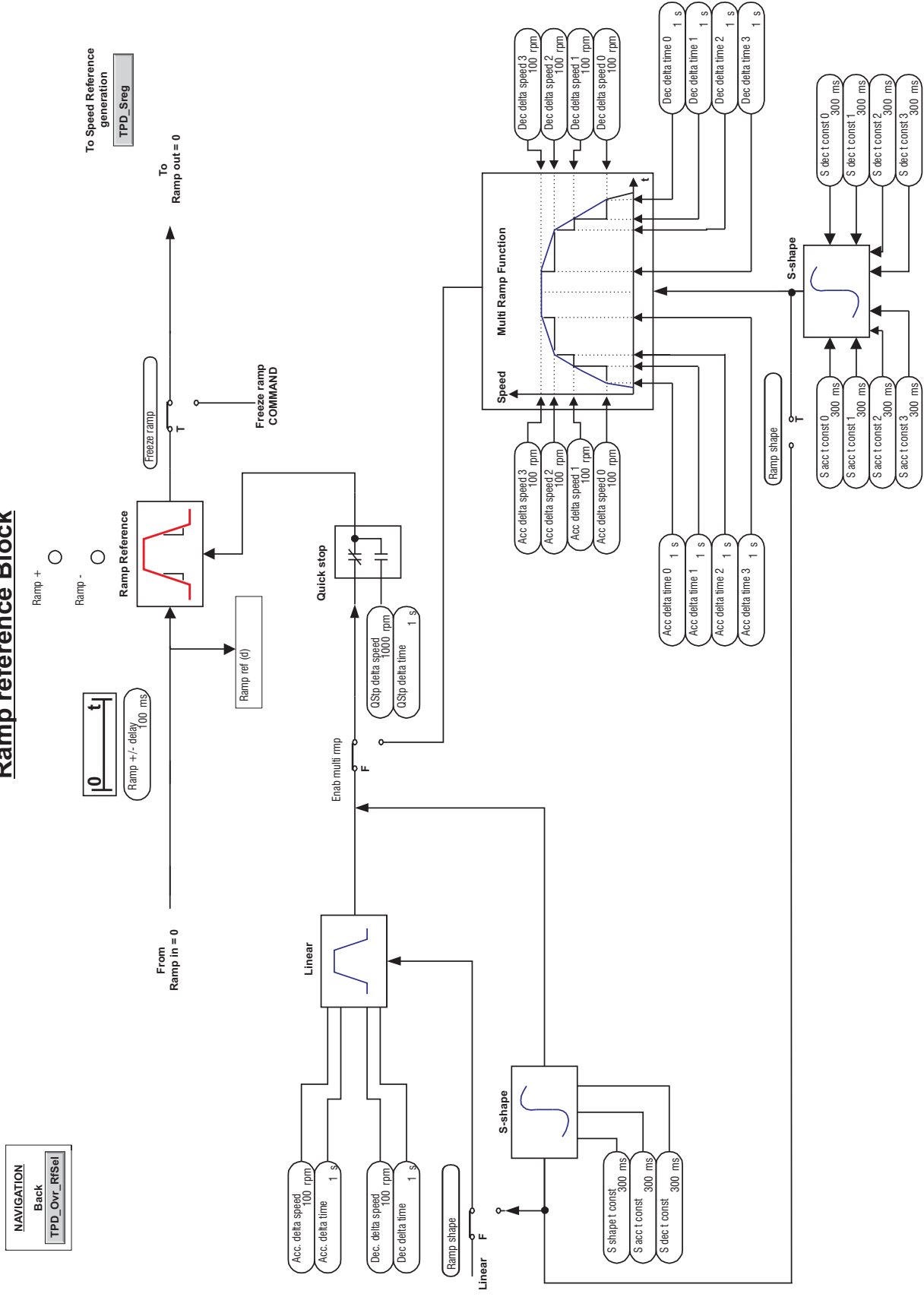

TPD\_Ramp.vsd

# Speed / Current Regulator Overview

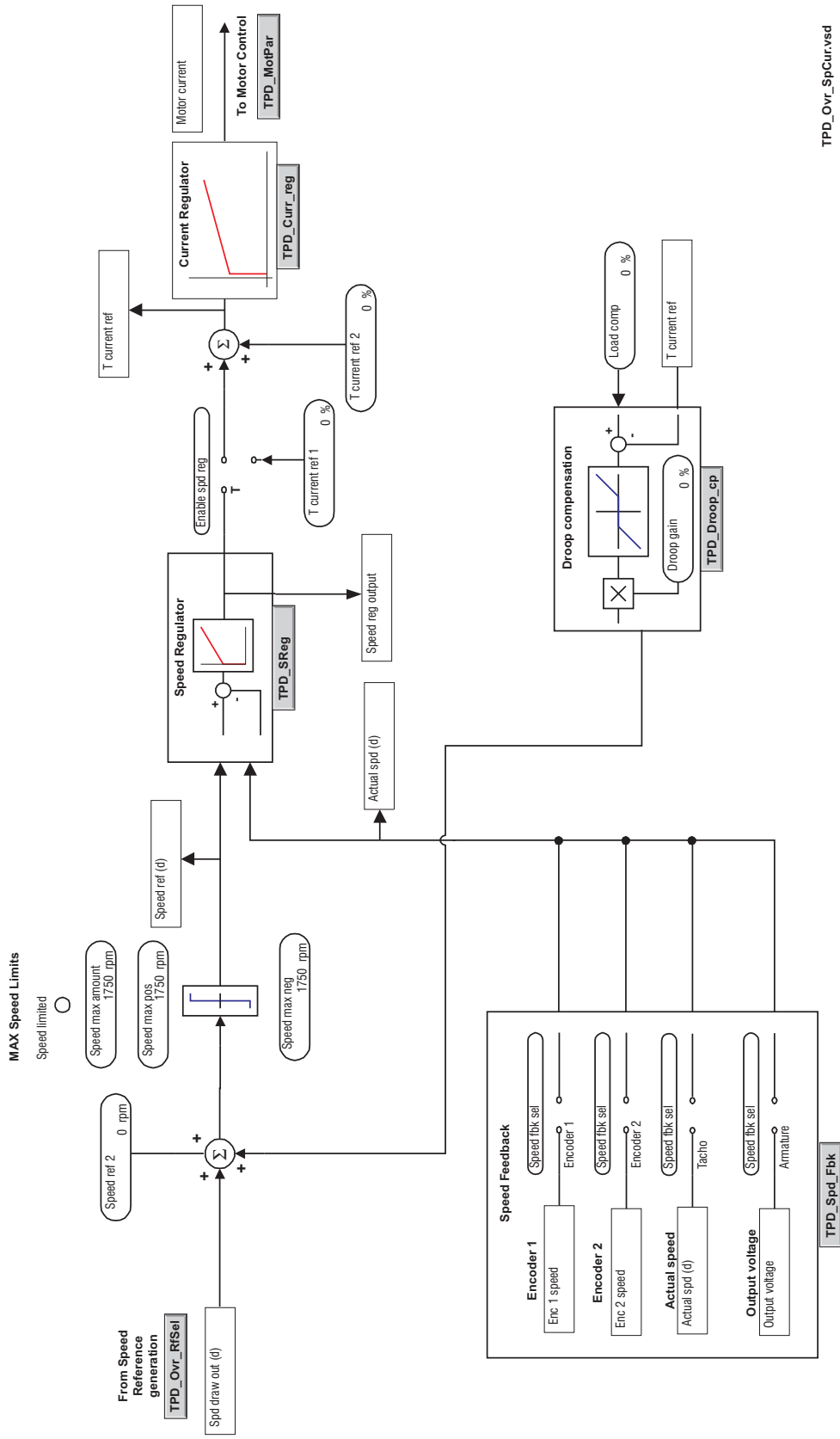

TPD\_Ovr\_SpCurvsd

# Speed Feedback setting

**NAVIGATION**  
[Back to Overview](#)  
[TPD\\_Ovw](#)

**Armature Fbk Bypass**  
 Enable fbk bypass  
 Disabled

Speed fbk loss

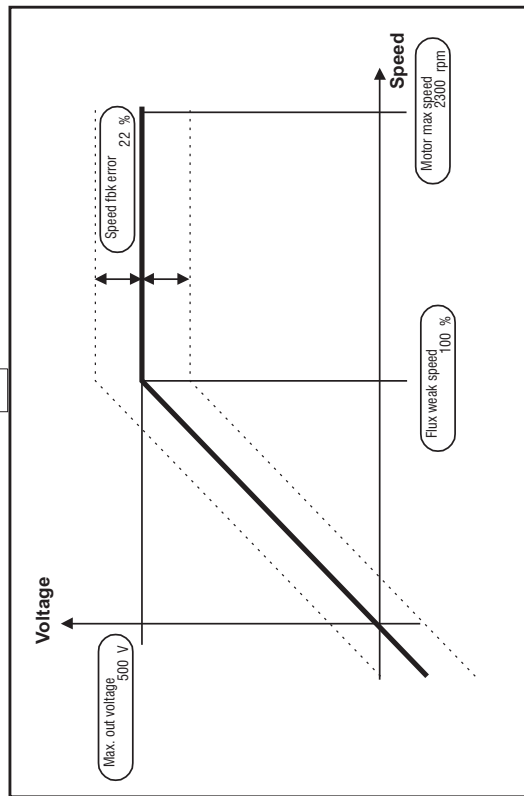

Enable fbk contr  
 Disabled

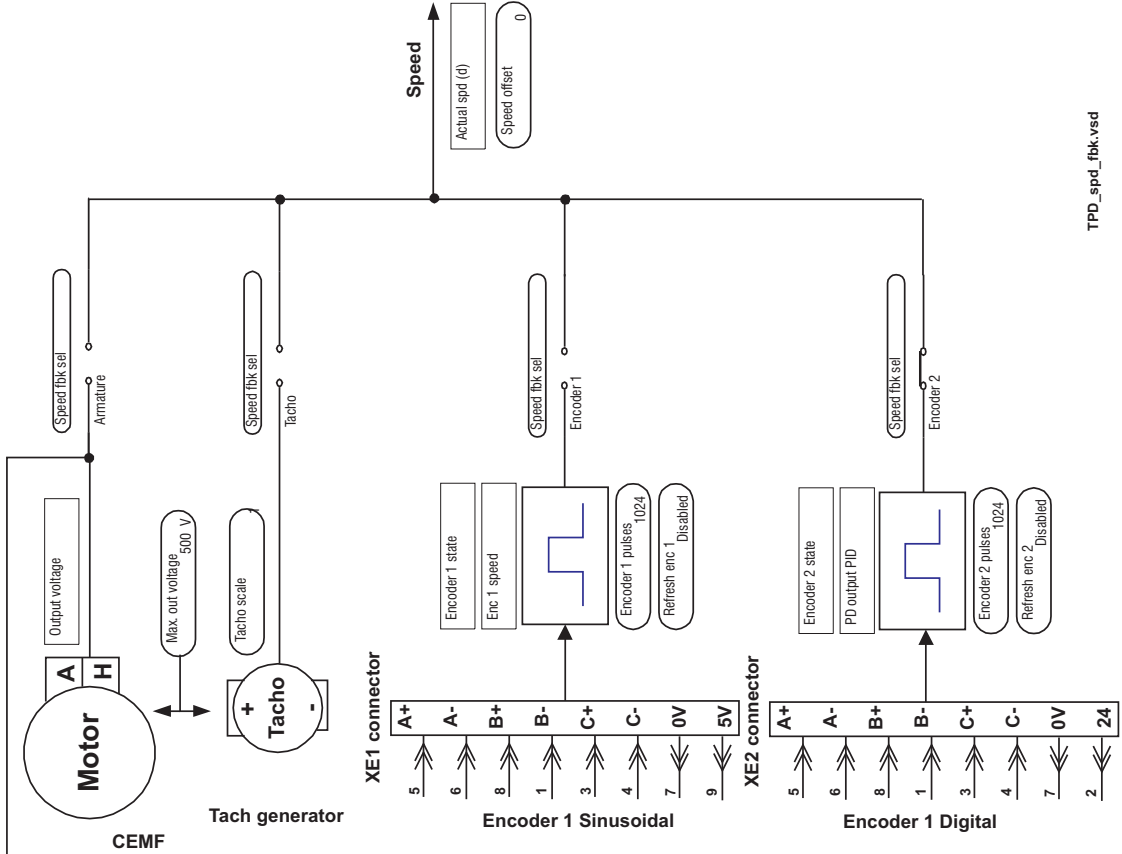
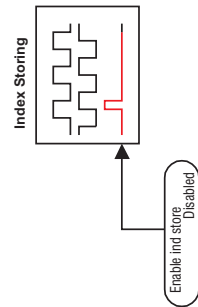

TPD\_spd\_fbk.vscd

# Speed regulator

NAVIGATION  
 Back  
 TPD\_OvV\_SpCur

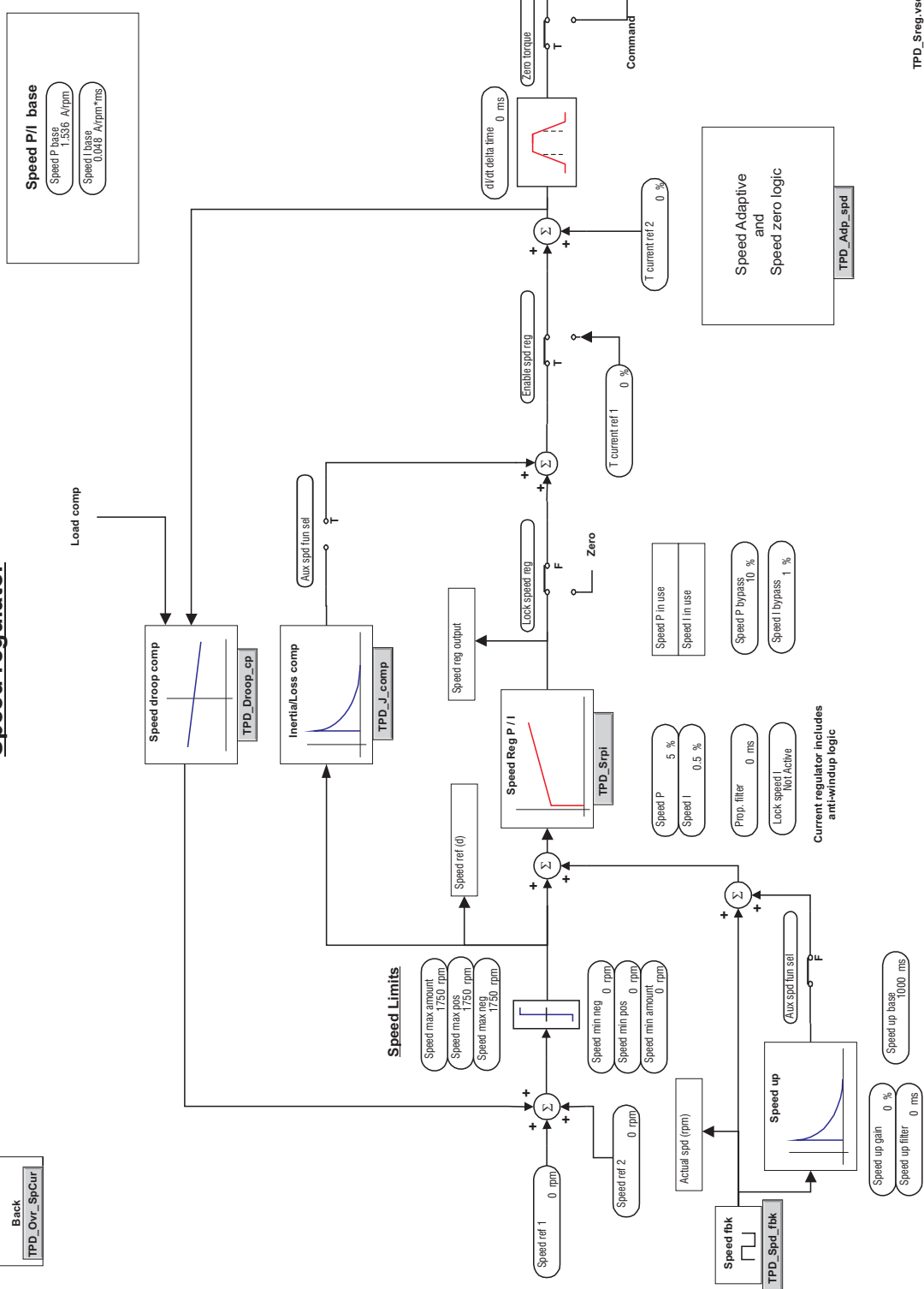

TPD\_Sreg.vsd

## Speed regulator PI part

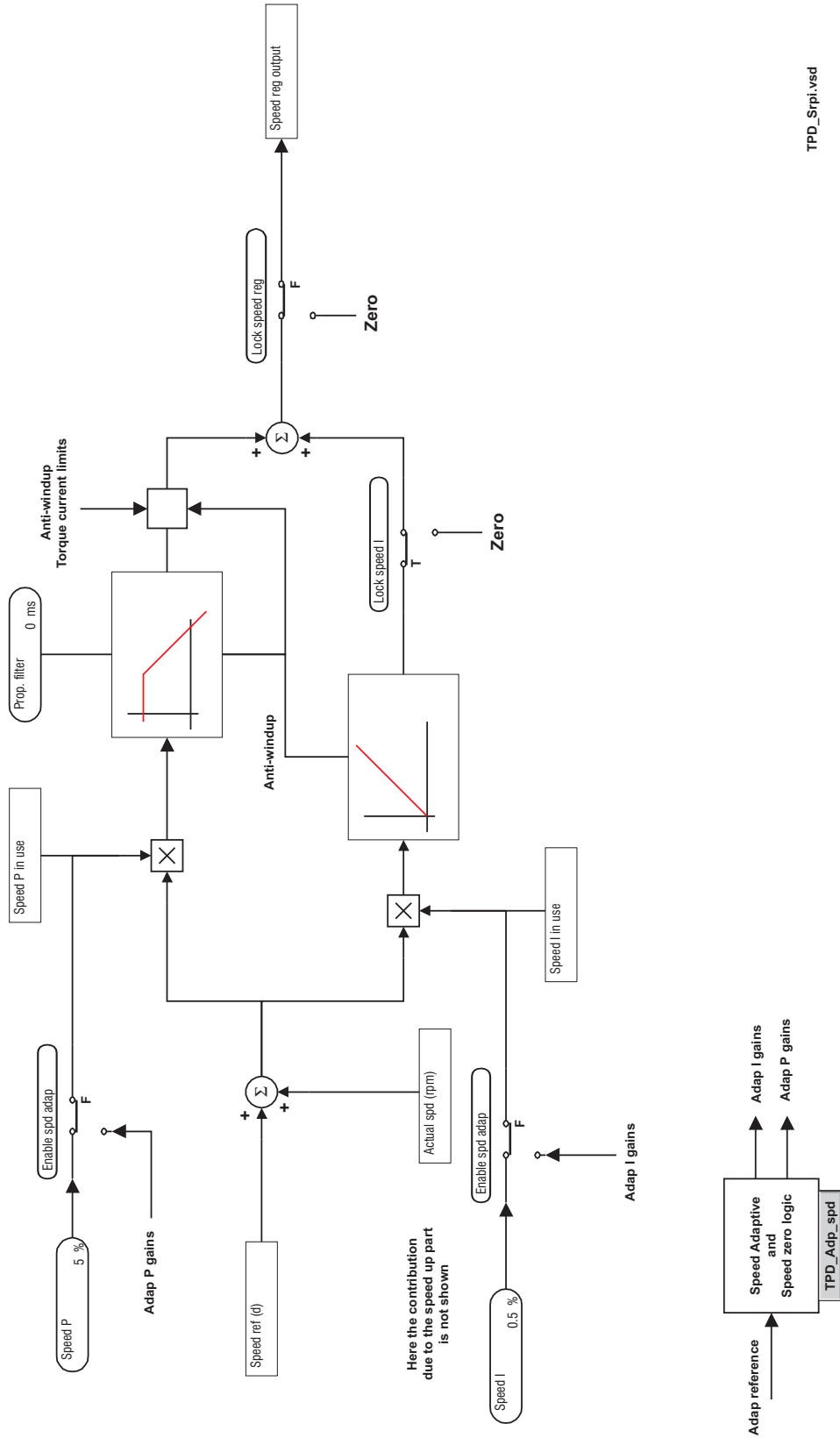

TPD\_Srpi.vsd

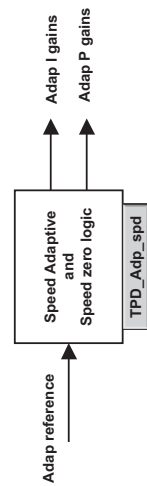

# Speed adaptive and Speed zero logic

## Speed Adap function

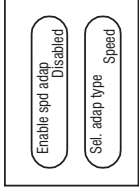
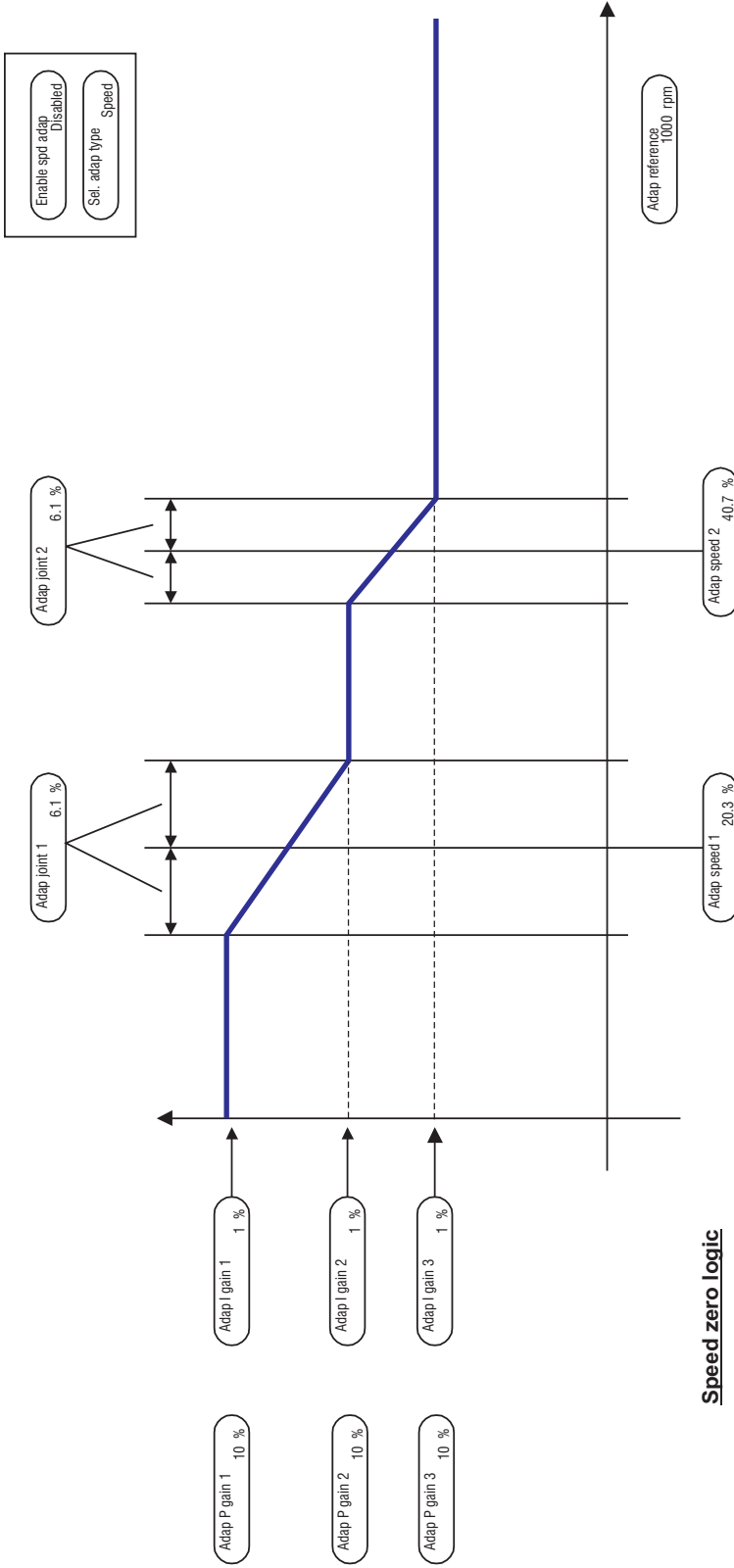

## Speed zero logic

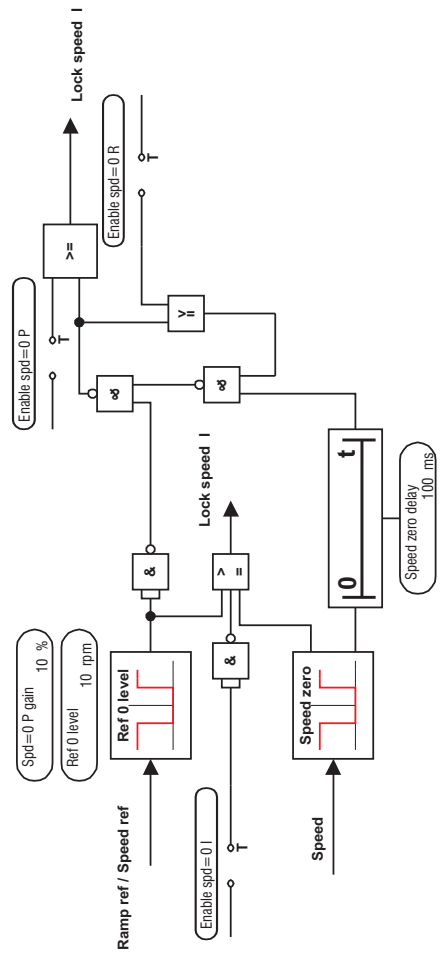

# Current regulator

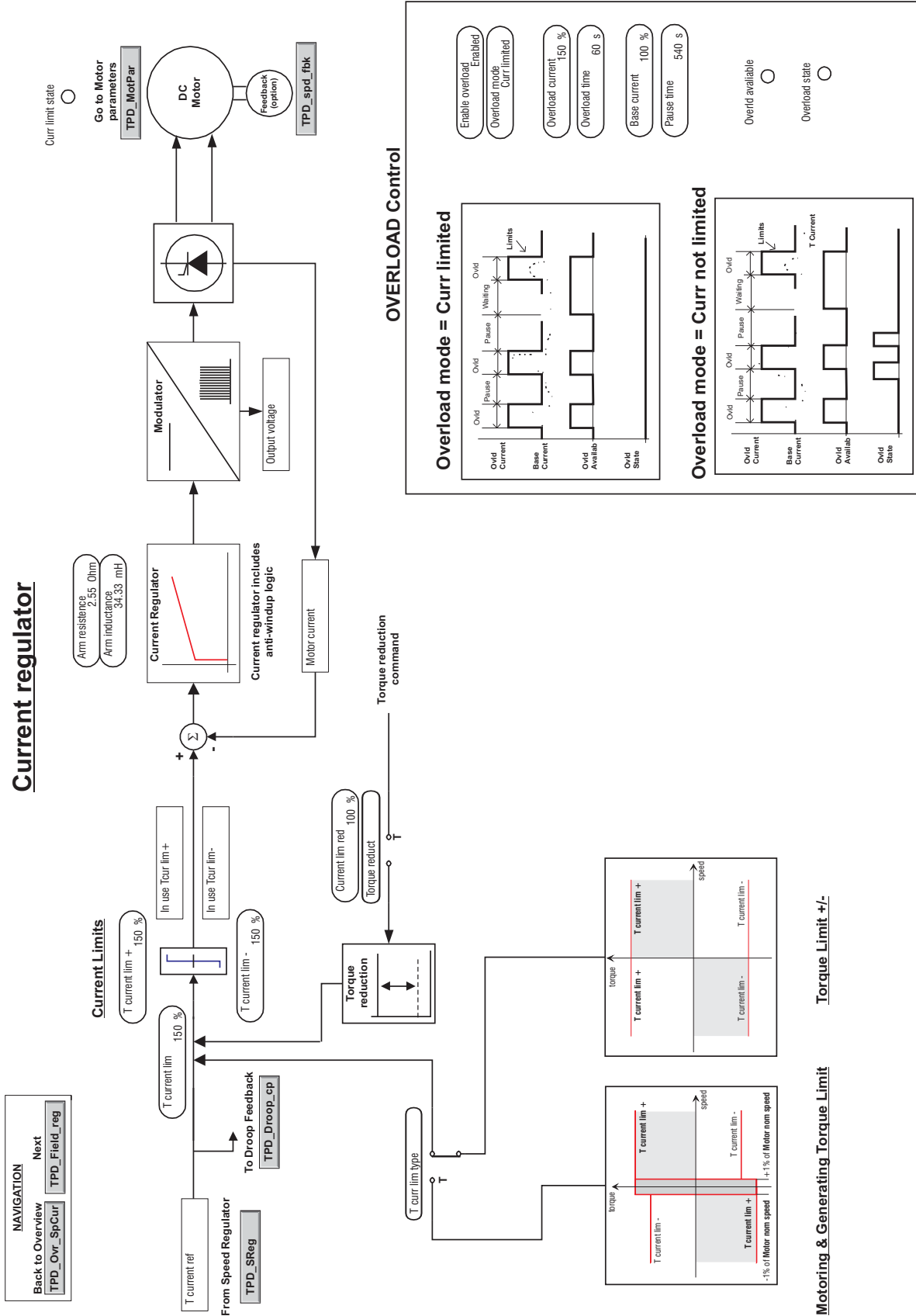

TPD\_Curr\_reg.vsd

# Field current regulator

NAVIGATION

Back Back

TPD\_Oww TPD\_Curr\_reg

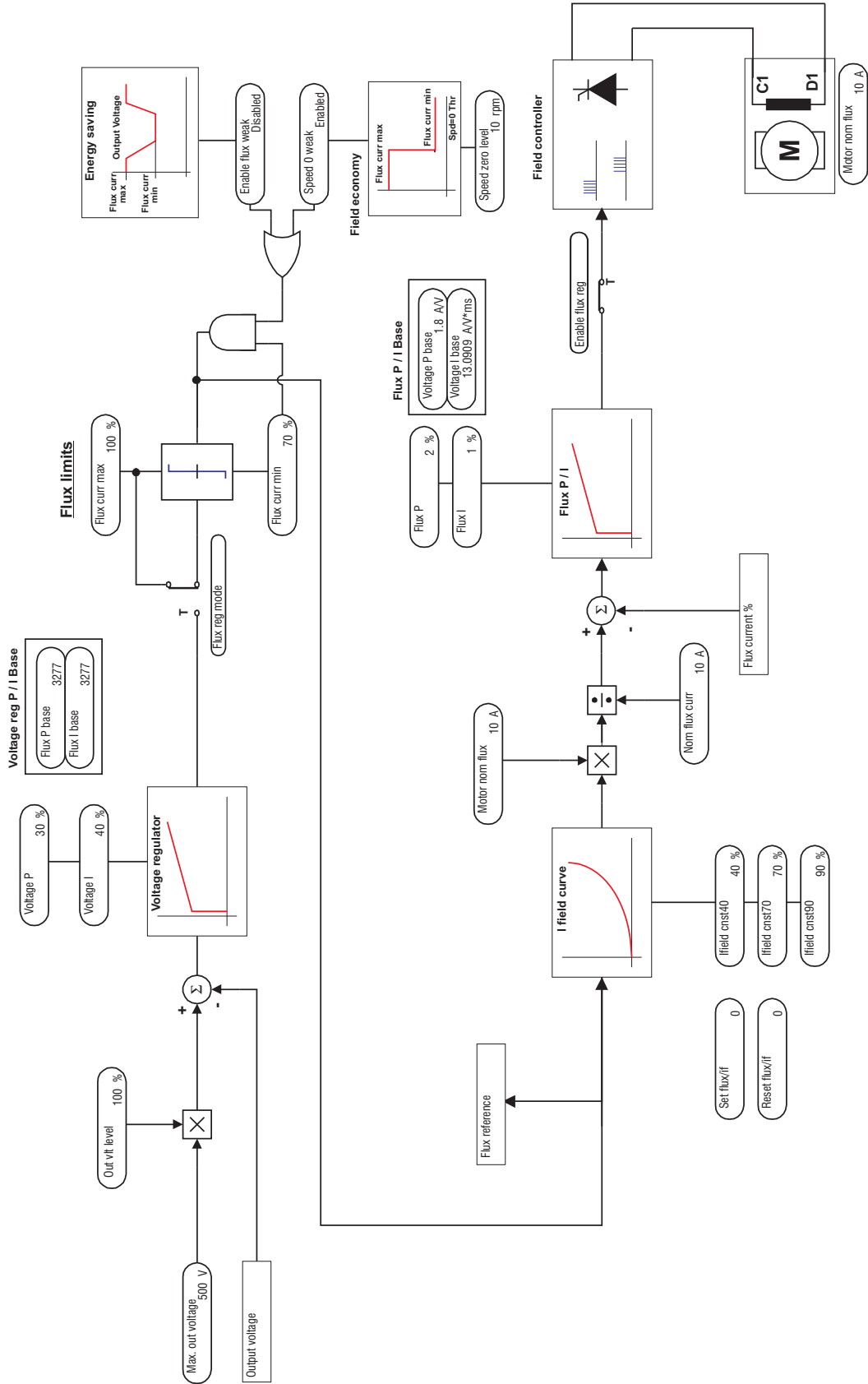

TPD\_Field\_reg\_vscd



# Motor parameters

[Back to Overview](#) | [Back to Curr\\_reg](#)  
[TPD\\_Ovw](#) | [TPD\\_Curr\\_reg](#)

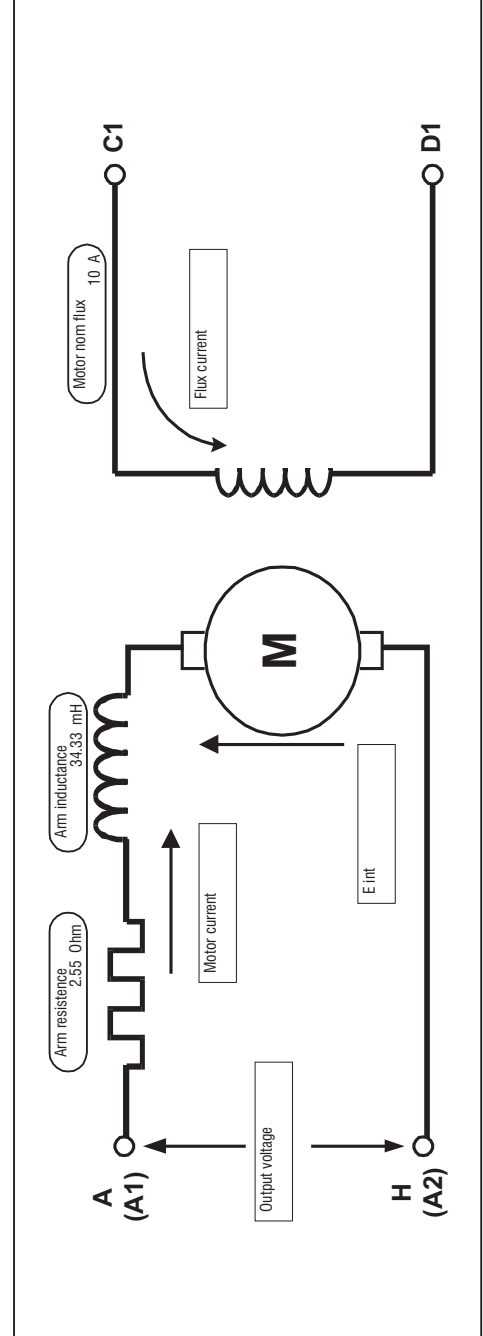
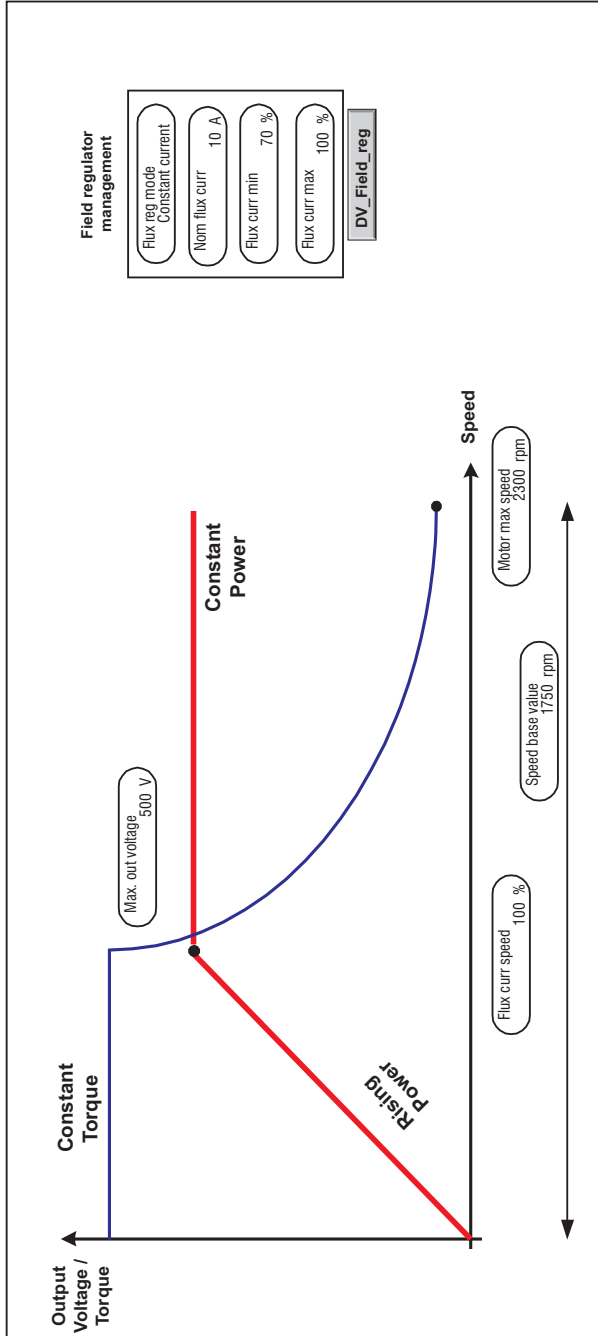

TPD\_MotPar.vsd

NAVIGATION

Overview

Go to functions

TPD\_Ovw

TPD\_Funct

# Start and Stop management

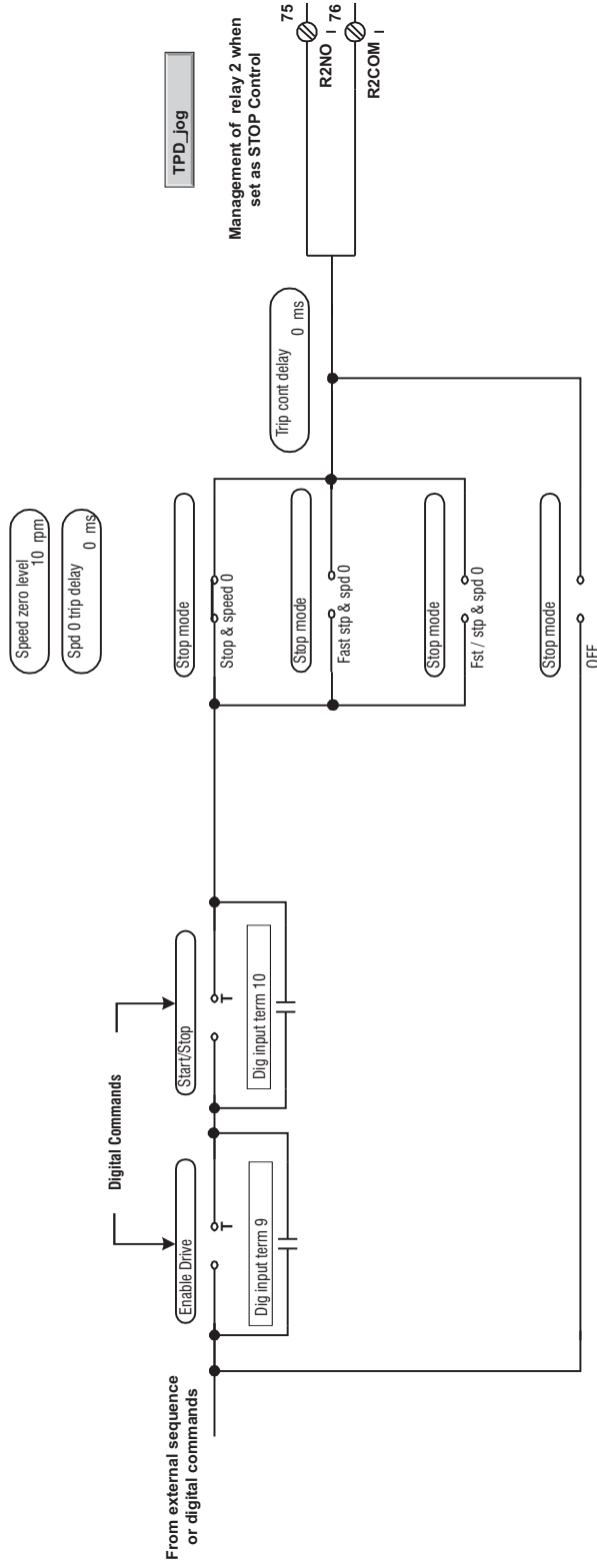

TPD\_STSP\_pro.vsd

# Droop compensation

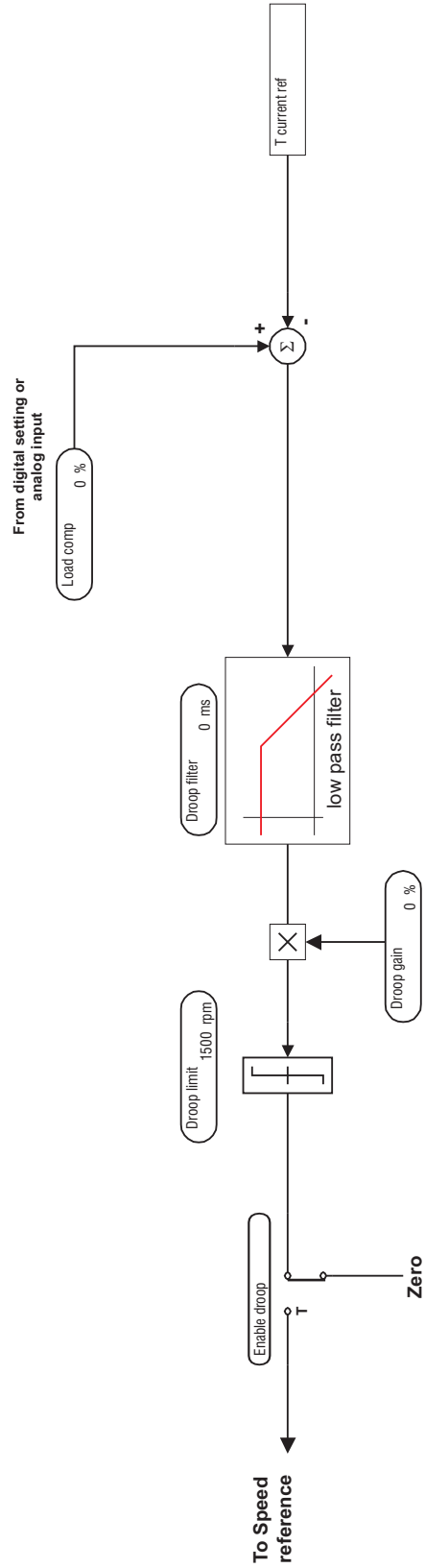

DV\_Droop\_cp.vsd

# Inertia/Loss compensation

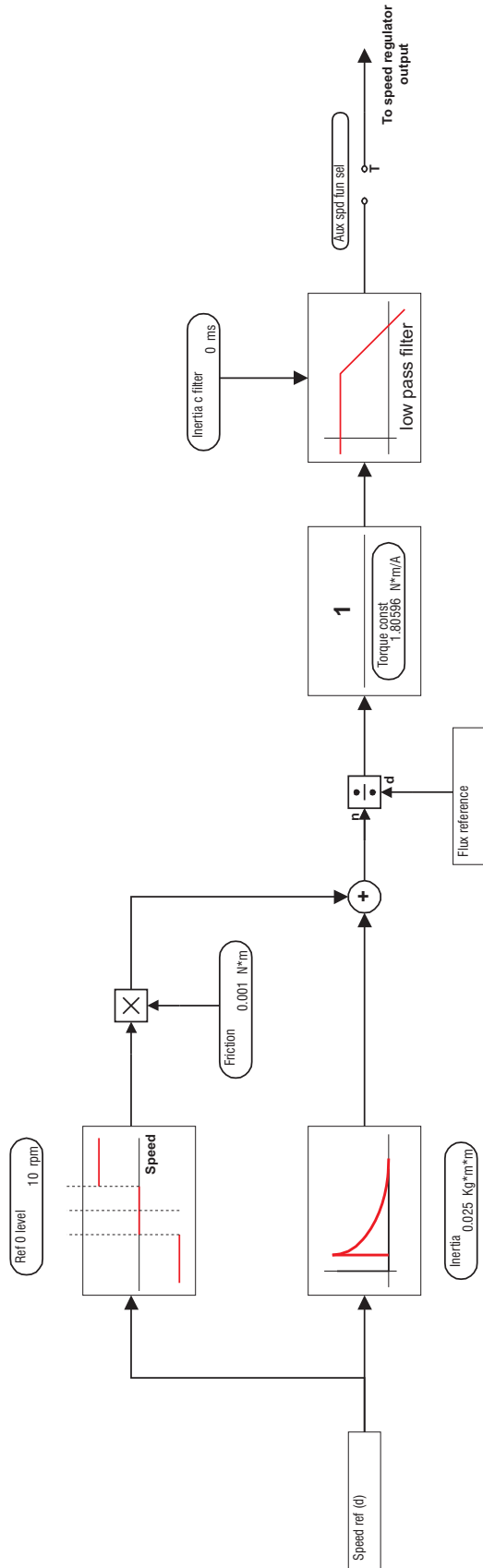

TPD\_J\_comp.vsd

# Speed Threshold / Speed control

NAVIGATION

Overview

Go to functions

TPD\_Ovw

TPD\_Funct

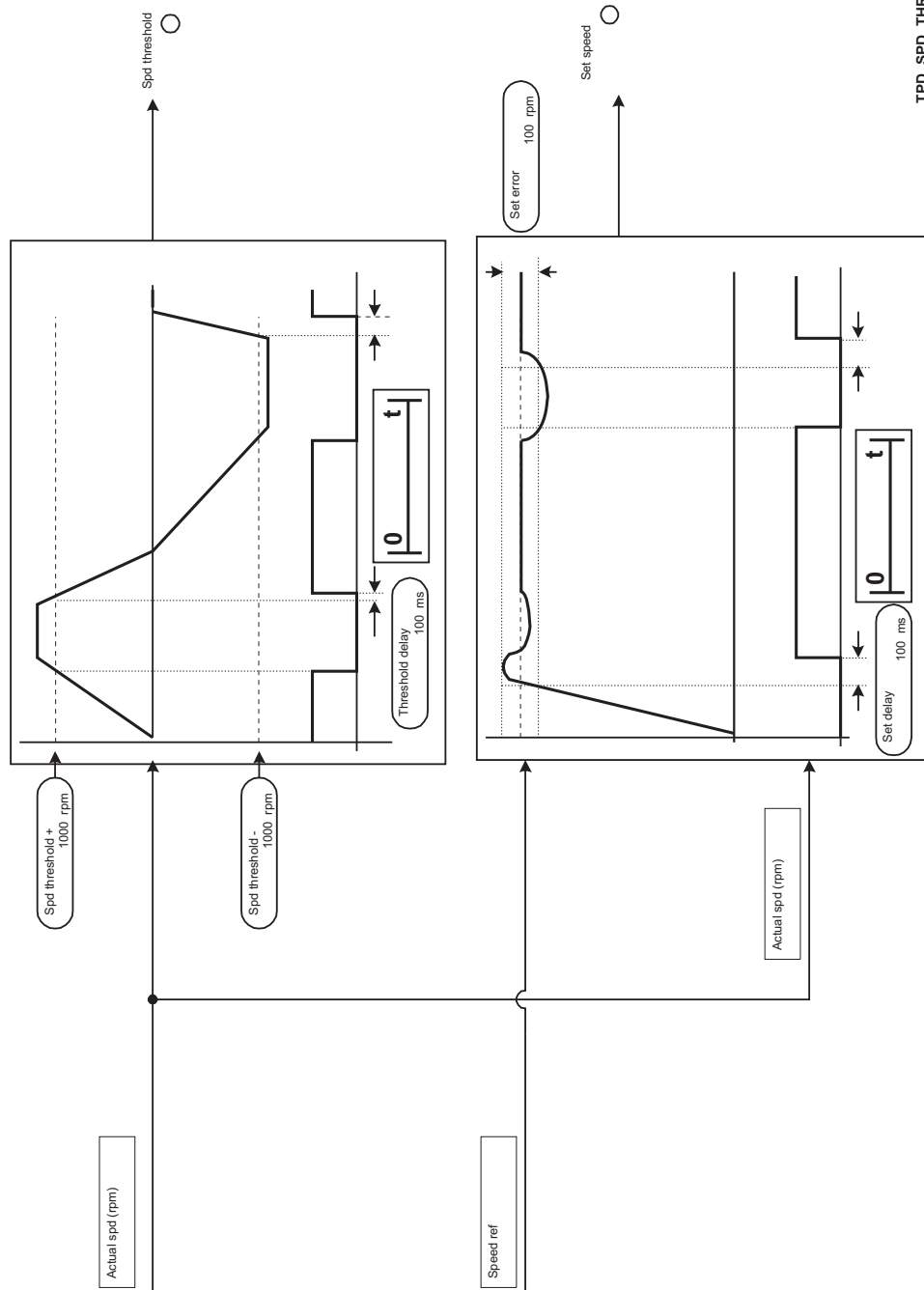

TPD\_SPD\_THR.vsd

# PID function

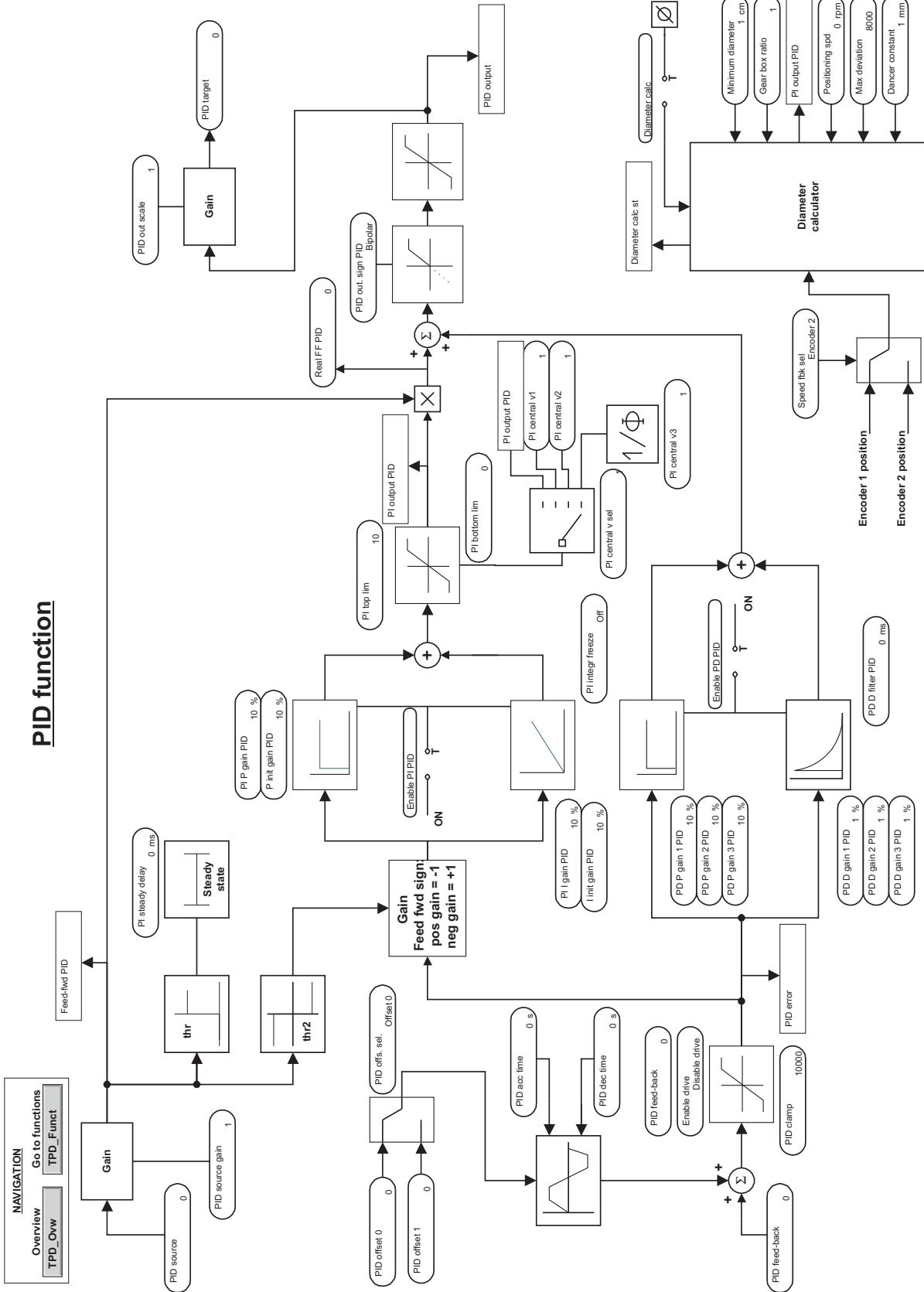

TPD\_PID.vsd

# Functions

NAVIGATION  
Back to Overview  
TPD\_OWw

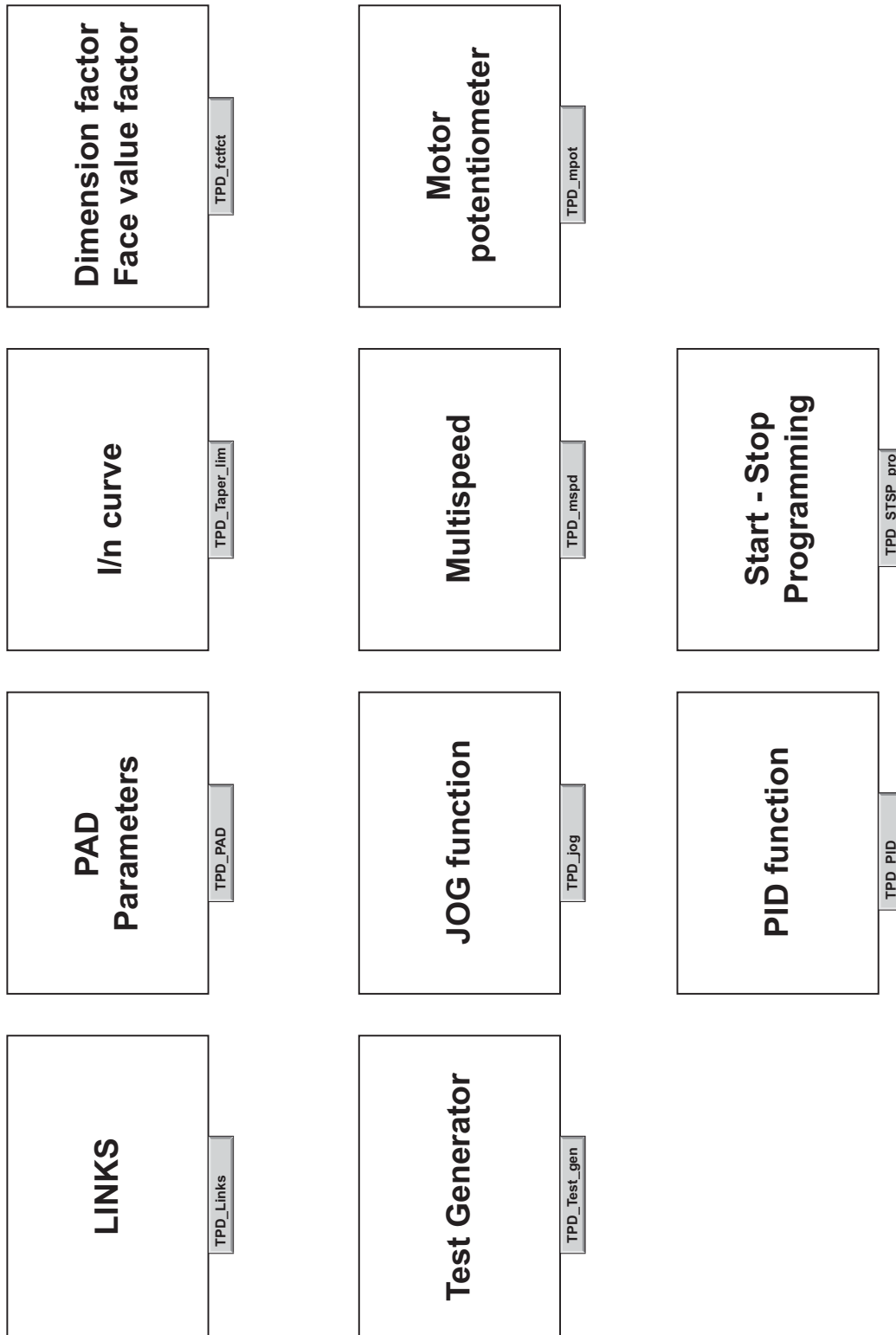

TPD\_Funct.vsd

# LINKS Function

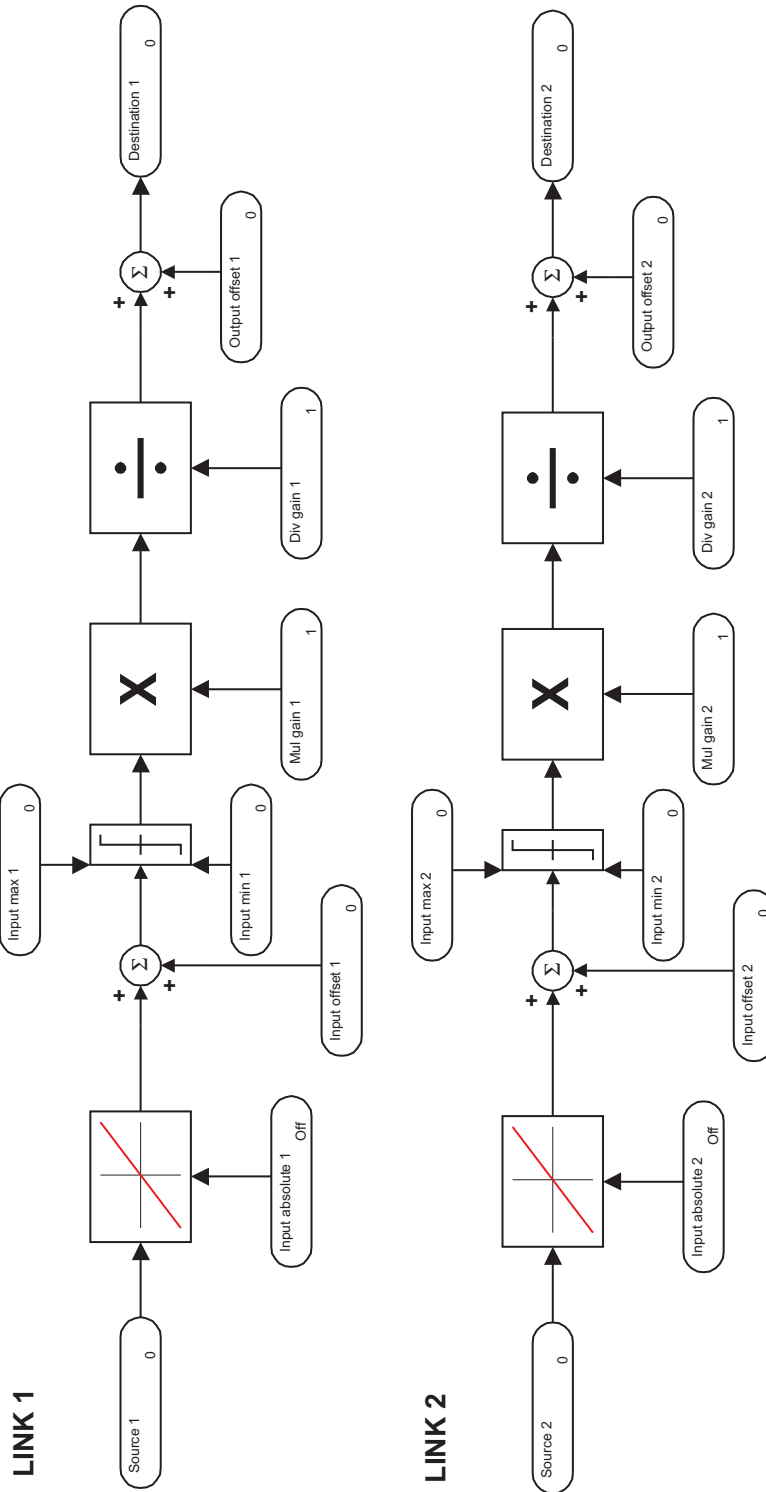

TPD\_Links.vsd



# PAD parameters

**NAVIGATION**  
 Overview  
 Go to functions  
 TPD\_Ovw  
 TPD\_Funct

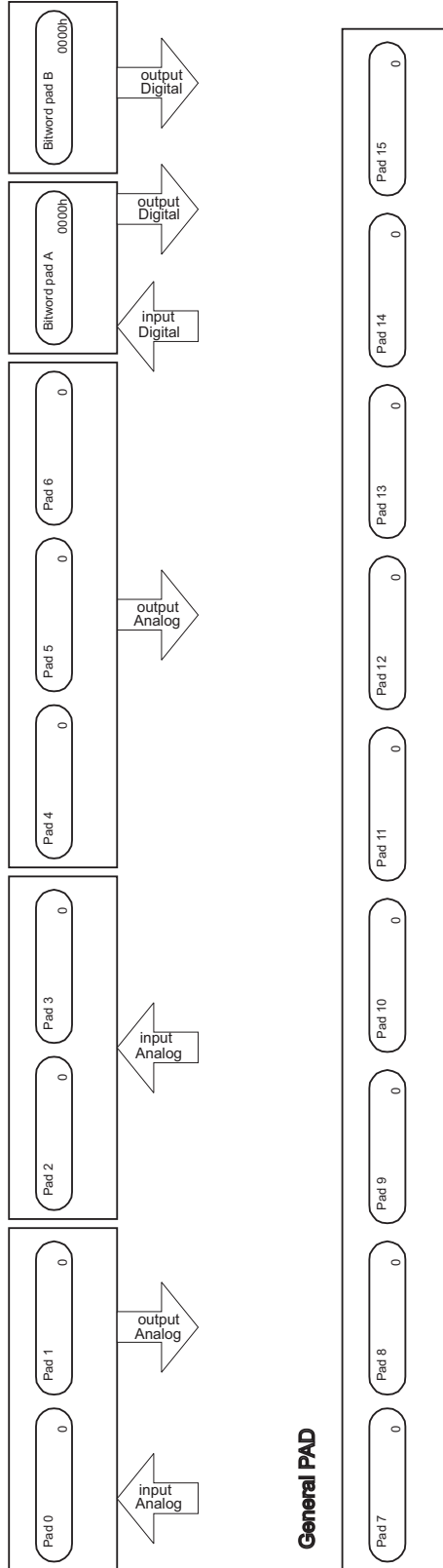

TPD\_pad.vsd

# Taper Current Limits

NAVIGATION

Back to Overview

Back to Function

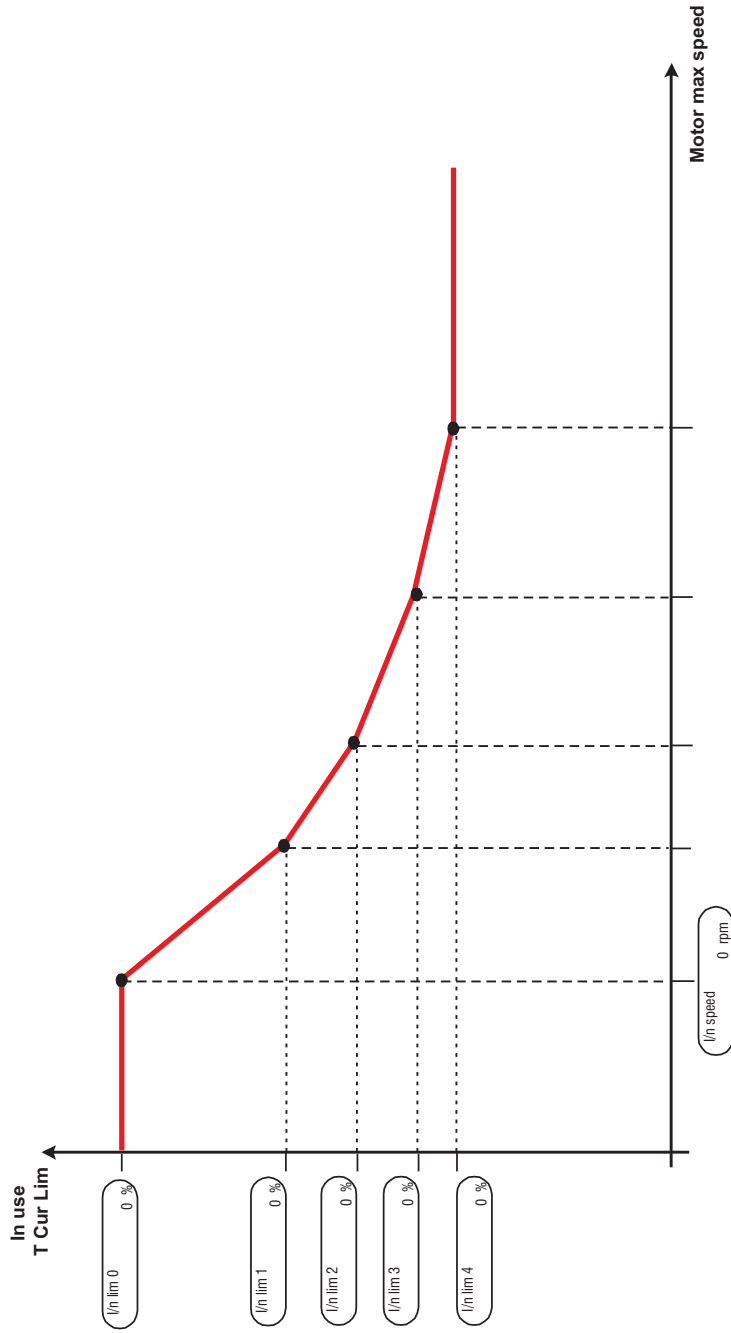

TPD\_Taper\_lim.vsd

**Dimension factor**  
**Face value factor**

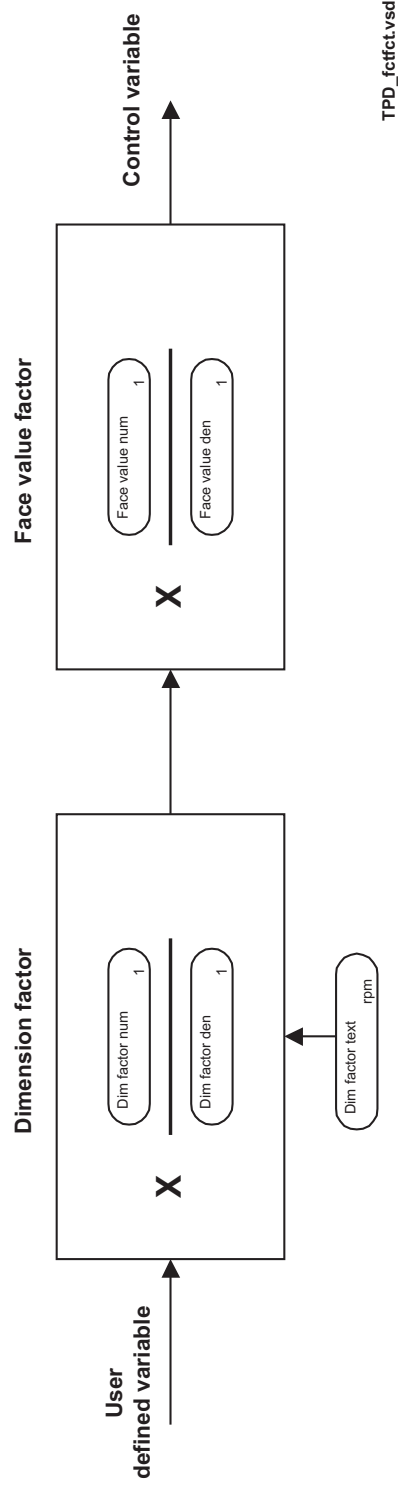

**NAVIGATION**

Overview

TPD\_Ovw

Go to functions

TPD\_Funct

# Test Generator

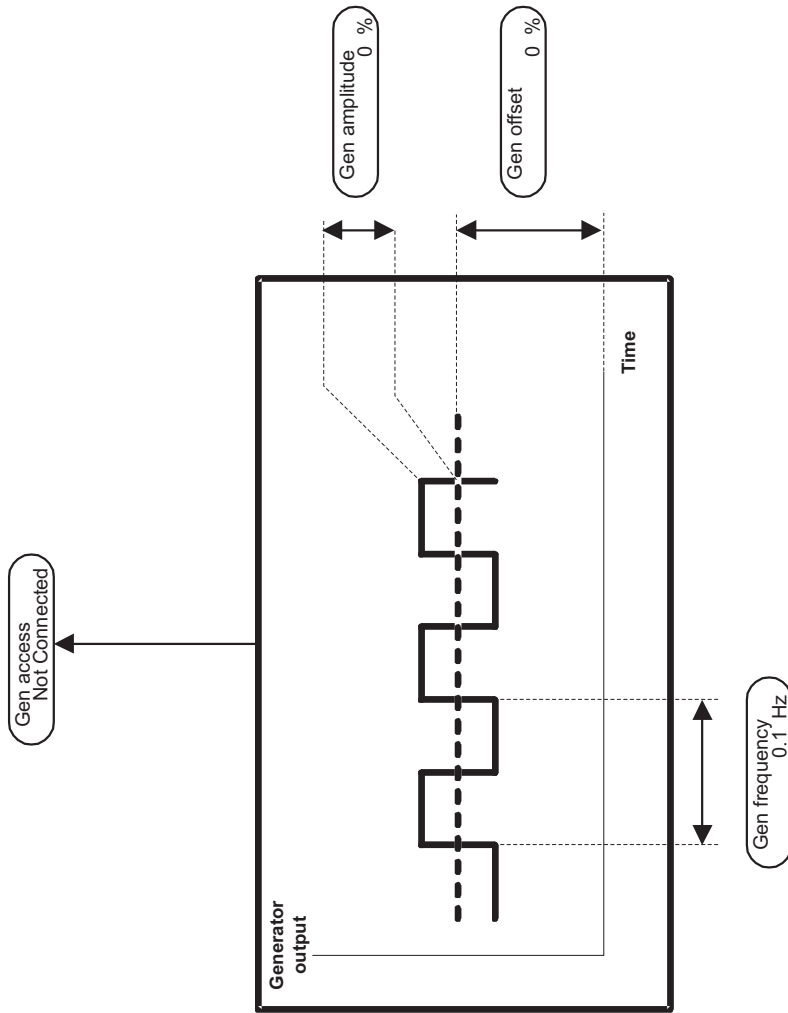

TPD\_Test\_gen.vsd

# JOG function

NAVIGATION

Go to functions

TPD\_Ovw

TPD\_Funct

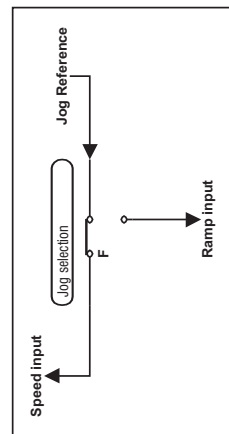
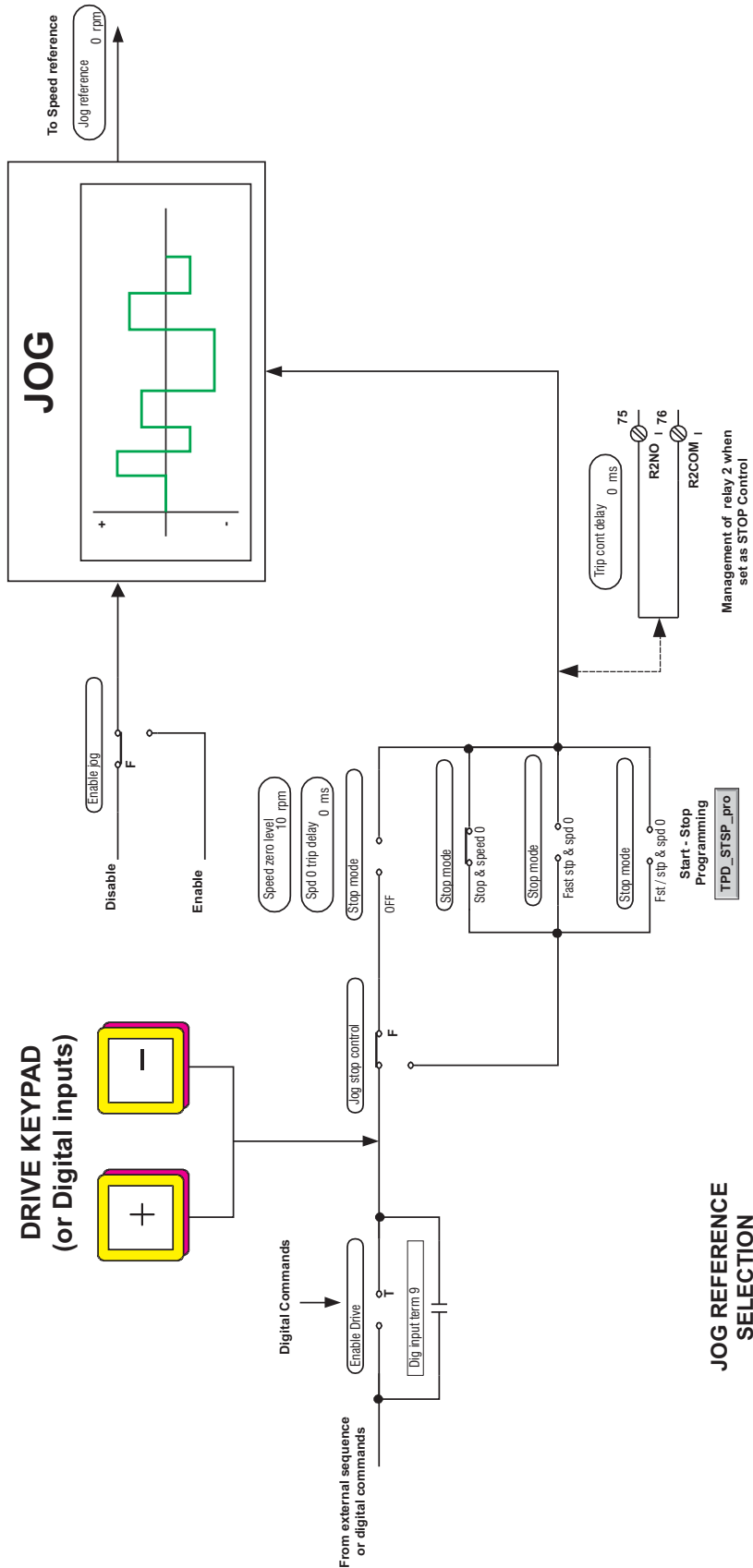

TPD\_jog.vsd

## Multi speed

Enable multi spd. Disabled

Multi speed sel. 0

Ramp ref (d)

| Speed sel 0<br>Bit 0 Not Selected | Speed sel 1<br>Bit 1 Not Selected | Speed sel 2<br>Bit 2 Not Selected | REFERENCE                           |
|-----------------------------------|-----------------------------------|-----------------------------------|-------------------------------------|
| 0                                 | 0                                 | 0                                 | Ramp ref 1 0 rpm + Ramp ref 2 0 rpm |
| 1                                 | 0                                 | 0                                 | Multi speed 1 0 rpm                 |
| 0                                 | 1                                 | 0                                 | Multi speed 2 0 rpm                 |
| 1                                 | 1                                 | 0                                 | Multi speed 3 0 rpm                 |
| 0                                 | 0                                 | 1                                 | Multi speed 4 0 rpm                 |
| 1                                 | 0                                 | 1                                 | Multi speed 5 0 rpm                 |
| 0                                 | 1                                 | 1                                 | Multi speed 6 0 rpm                 |
| 1                                 | 1                                 | 1                                 | Multi speed 7 0 rpm                 |

# Motor potentiometer

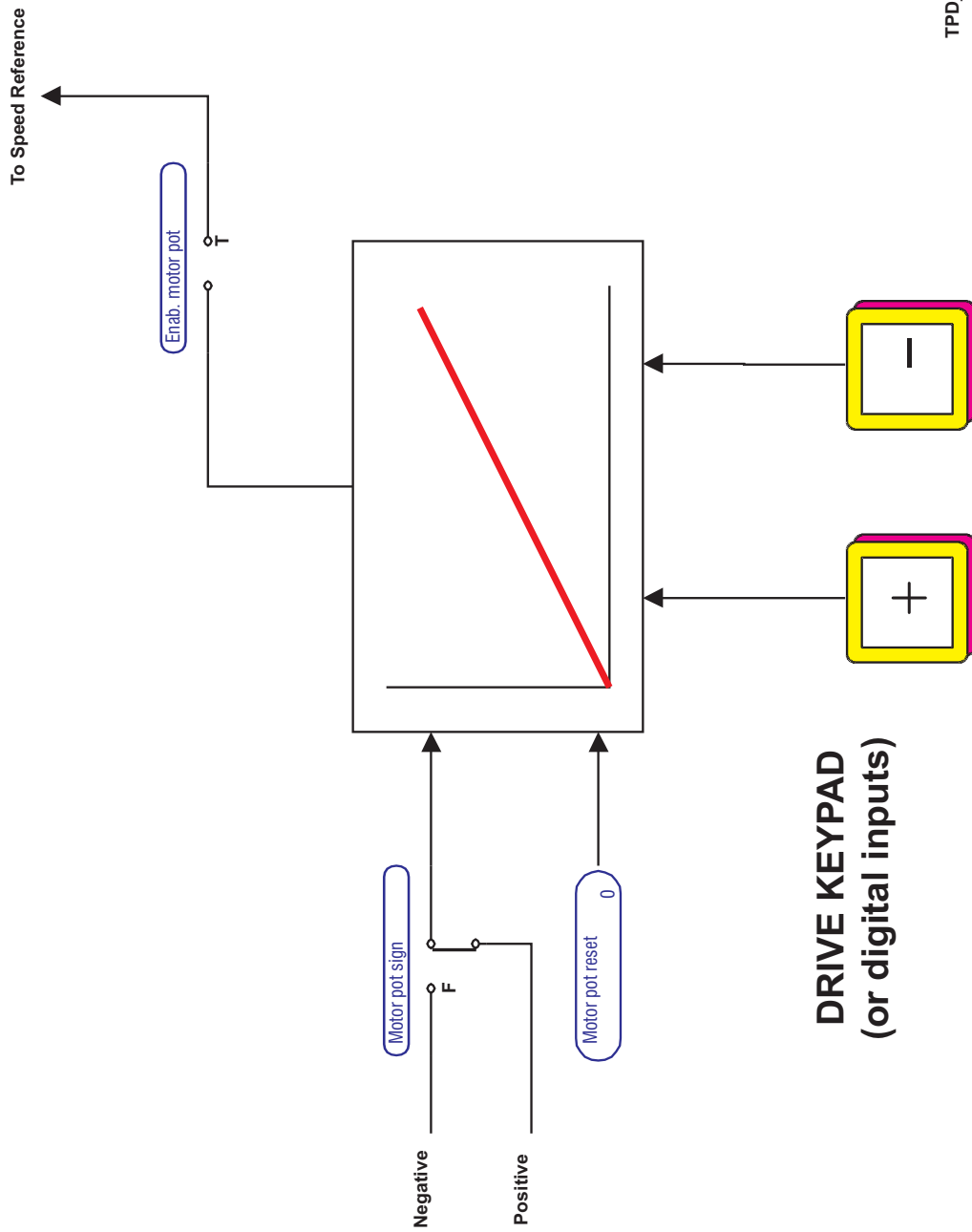

TPD\_mpot.vsd

# Alarm mapping

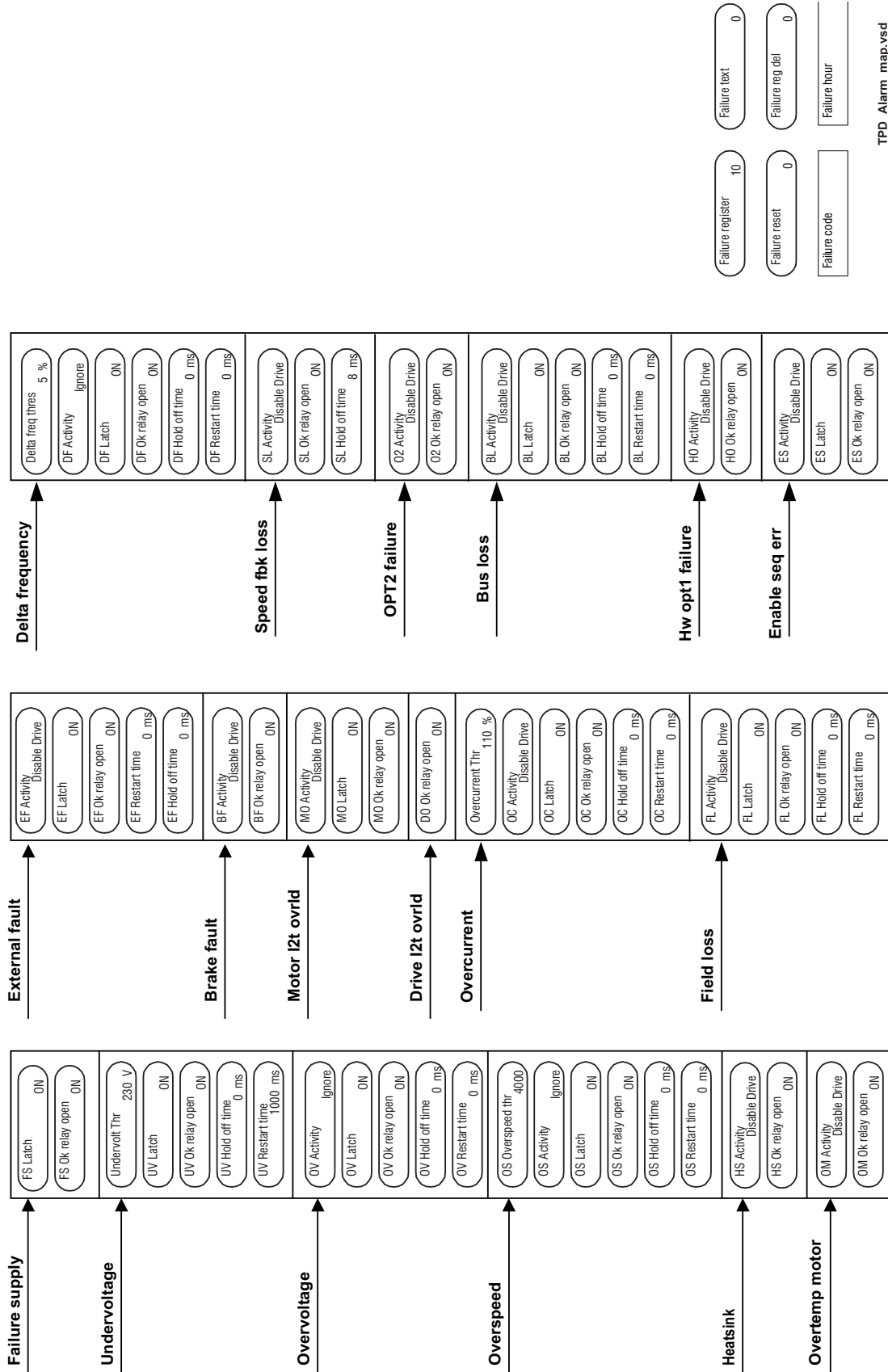

TPD\_Alarm\_map.vsd



## 9.2 POWER CIRCUIT BLOCK DIAGRAMS

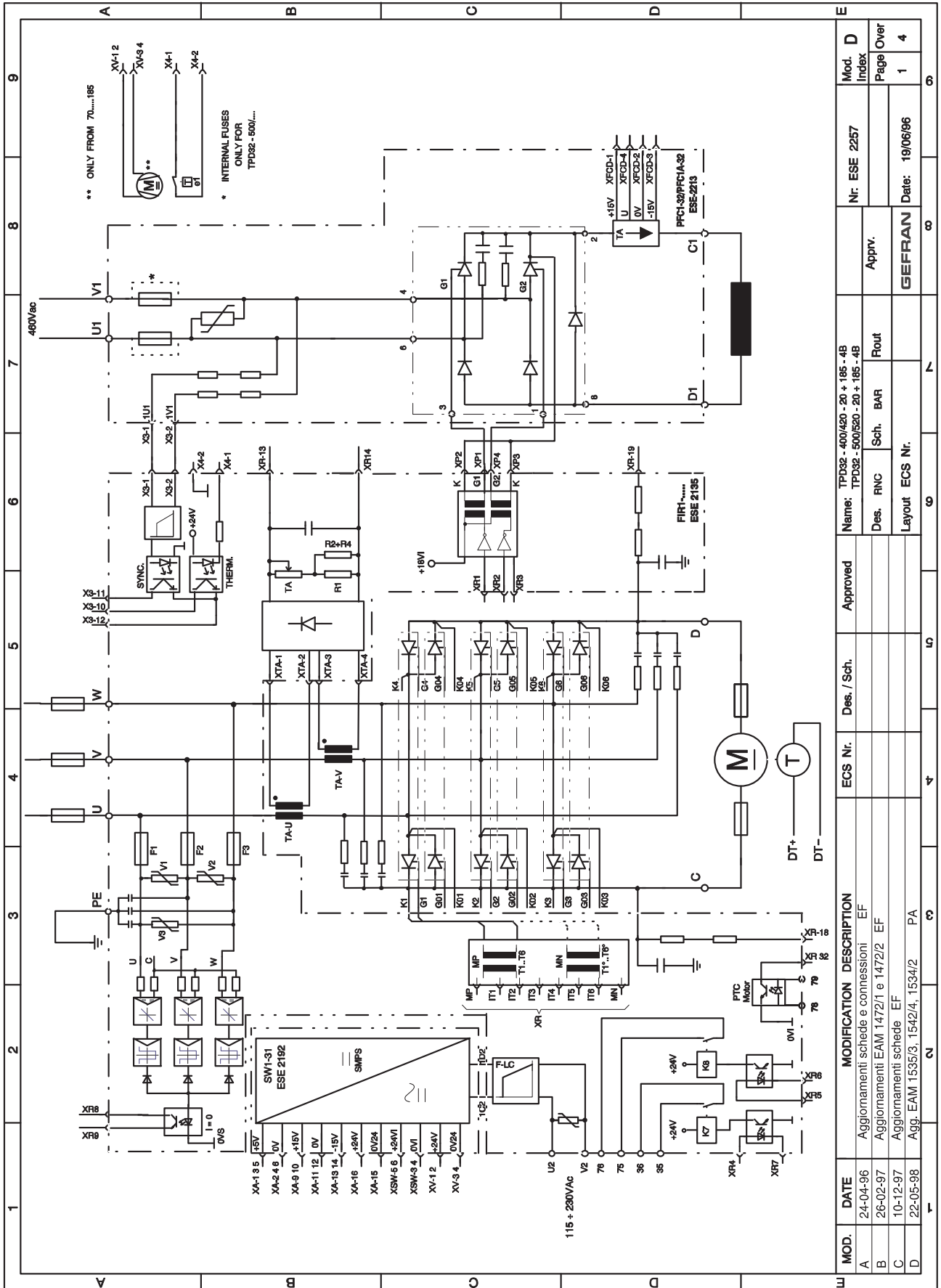

| MOD. | DATE     | MODIFICATION DESCRIPTION              | ECS Nr. | Des. / Sch. | Approved | Name:                           | Nr.      | Mod. Index |
|------|----------|---------------------------------------|---------|-------------|----------|---------------------------------|----------|------------|
| A    | 24-04-96 | Aggiornamenti schede e connessioni EF |         |             |          | TPD32 - 400/420 - 20 + 165 - 4B | ESE 2257 | D          |
| B    | 26-02-97 | Aggiornamenti EAM 1472/1 e 1472/2 EF  |         |             |          | TPD32 - 500/520 - 20 + 165 - 4B |          |            |
| C    | 10-12-97 | Aggiornamenti schede EF               |         |             |          |                                 |          |            |
| D    | 22-05-98 | Agg. EAM 1535/3, 1542/4, 1534/2 PA    |         |             |          |                                 |          |            |

  

| Des. | RNC | Sch. | BAR | Rout | Apprv. | Nr.      | Date:    |
|------|-----|------|-----|------|--------|----------|----------|
|      |     |      |     |      |        | ESE 2257 | 19/06/96 |

| Layout | ECS Nr. | Page | Over |
|--------|---------|------|------|
|        |         | 1    | 4    |

**GEFRAN**

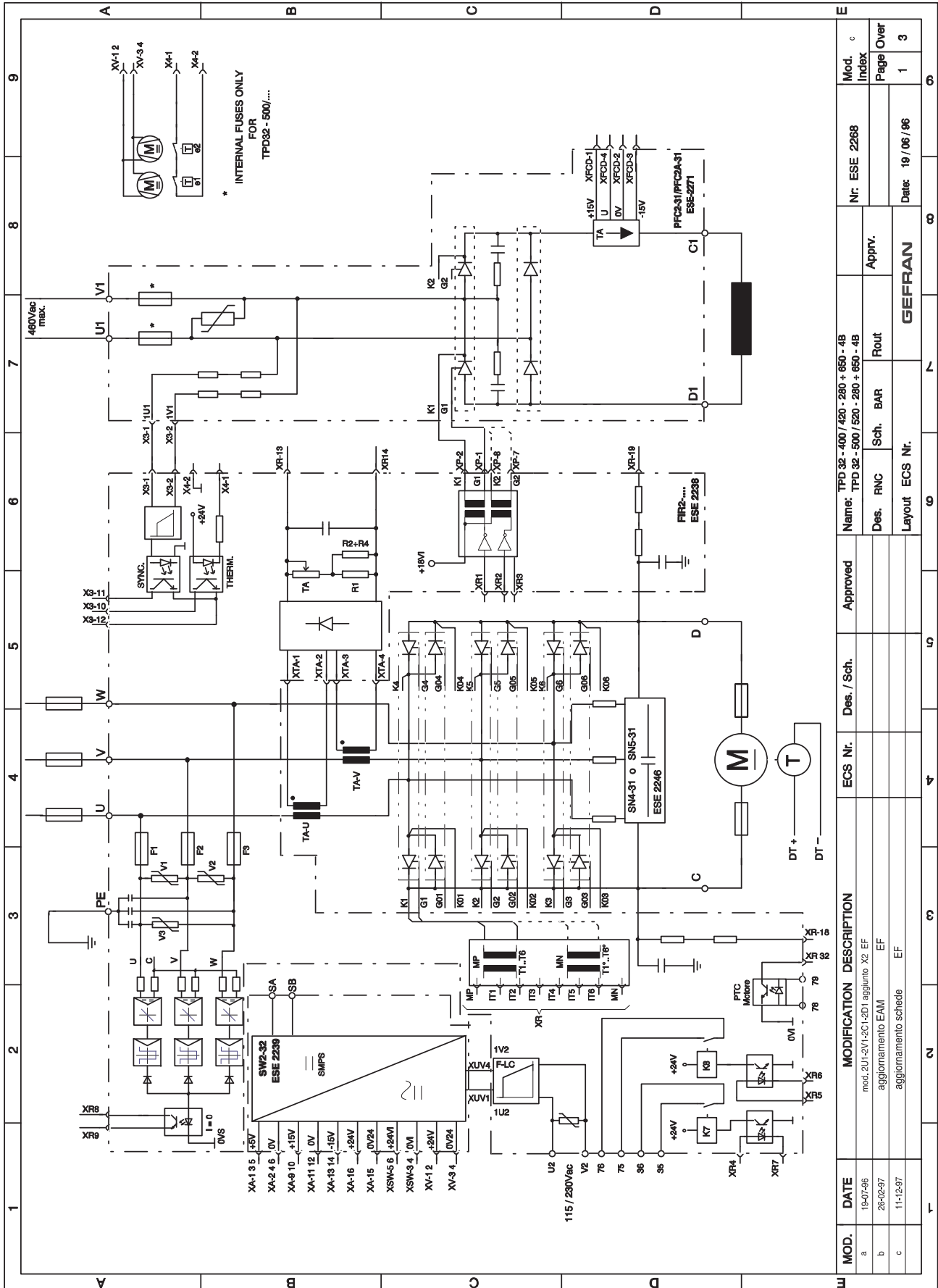

| MOD. | DATE     | MODIFICATION DESCRIPTION        | ECS Nr. | Des. / Sch. | Approved | Name:                               | Nr. ESE 2268 | Mod. Index |
|------|----------|---------------------------------|---------|-------------|----------|-------------------------------------|--------------|------------|
| a    | 19-07-86 | mod. 2U1-2C1-2D1 aggiunto X2 EF |         |             |          | TPD 32 - 400 / 450 - 280 + 650 - 48 |              |            |
| b    | 26-02-97 | aggiornamento EAM EF            |         |             |          | TPD 32 - 500 / 520 - 280 + 650 - 48 |              |            |
| c    | 11-12-97 | aggiornamento schede EF         |         |             |          |                                     |              |            |

| Des. RINC | Sch. BAR | Rout | Apprv. | Date:        |
|-----------|----------|------|--------|--------------|
|           |          |      |        | 19 / 08 / 96 |

  

| Layout ECS Nr. | GEFRAN |  |  |
|----------------|--------|--|--|
|                |        |  |  |

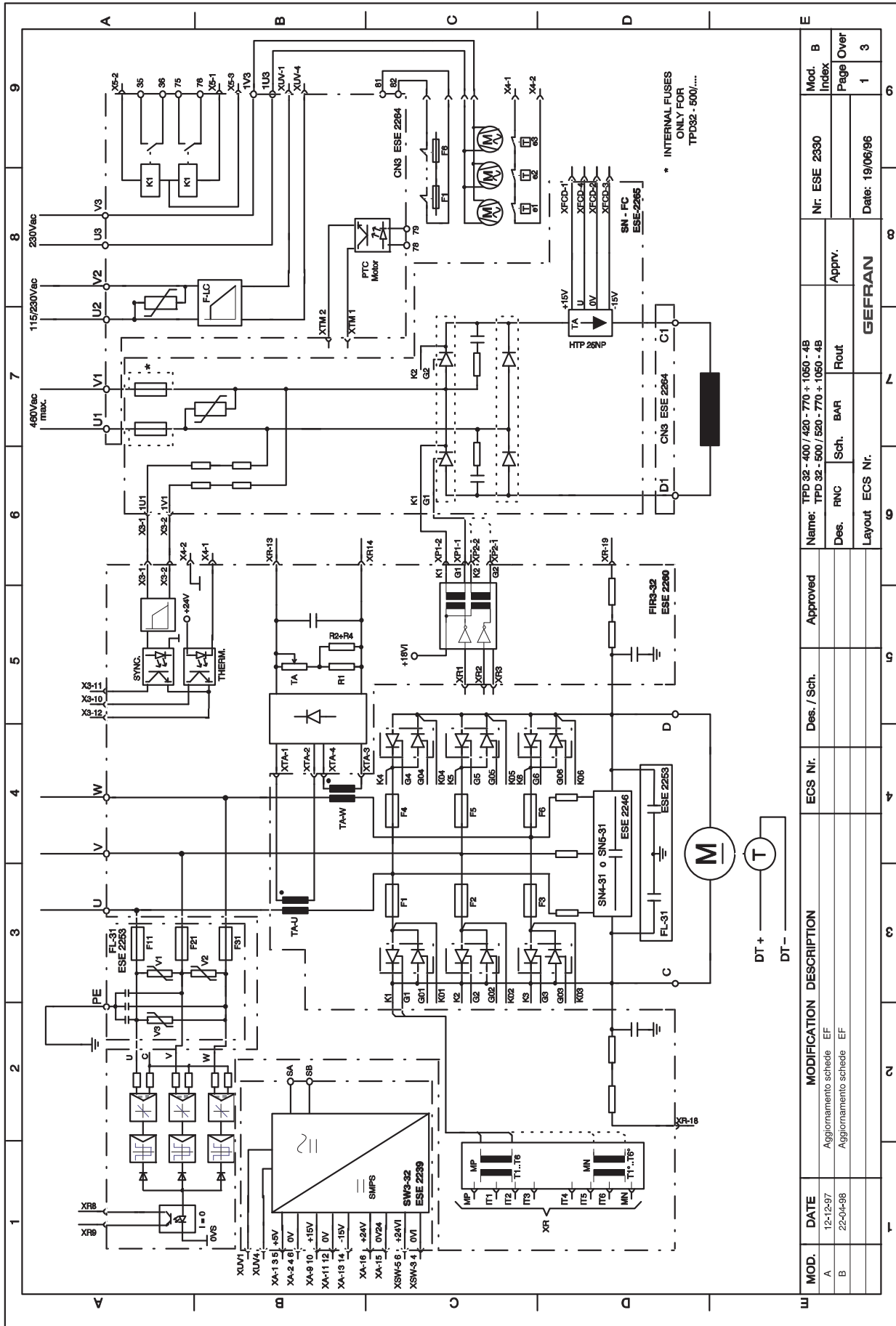

| MOD.                   | DATE     | DESCRIPTION             | ECS Nr. | Des. / Sch. | Approved | Name:                        | Nr. ESE        | Mod. B    |   |
|------------------------|----------|-------------------------|---------|-------------|----------|------------------------------|----------------|-----------|---|
| A                      | 12-12-97 | Aggiornamento scheda EF |         |             |          | TPD 32-400/420-770 + 1050-4B | 2330           | Index     |   |
| B                      | 22-04-98 | Aggiornamento scheda EF |         |             |          | TPD 32-500/520-770 + 1050-4B |                | Page Over |   |
| Layout ECS Nr. GEFFRAN |          |                         |         |             |          |                              | Date: 19/06/96 | 1         | 3 |

BLOCK DIAGRAM

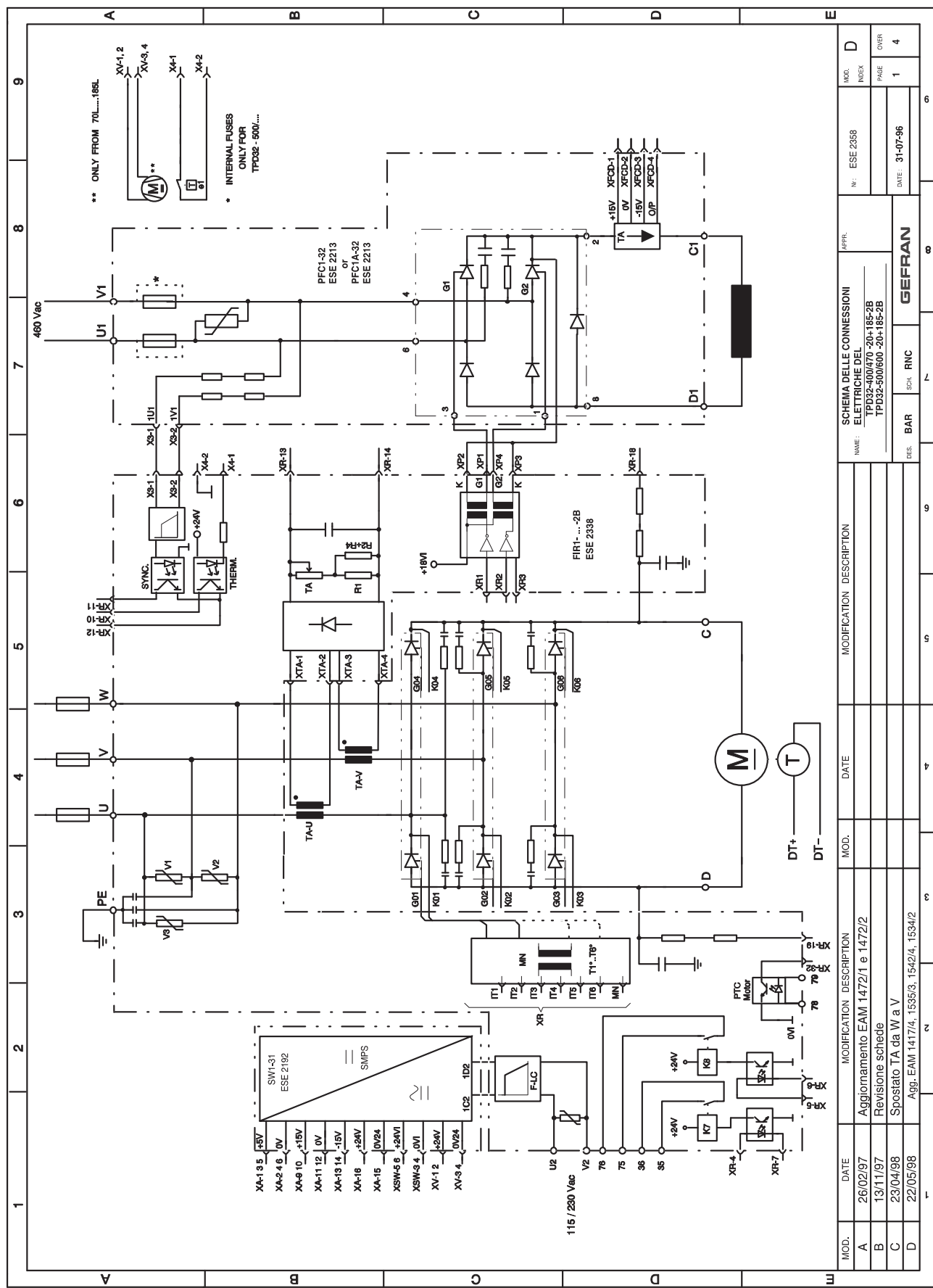

\*\* ONLY FROM 70L...165L

\* INTERNAL FUSES ONLY FOR TPD32 - 500/...

| MOD. | DATE     | MODIFICATION DESCRIPTION                | MOD. | DATE | MODIFICATION DESCRIPTION | APPR. | N°       | MOD. | INDEX |
|------|----------|---|------|------|--------------------------|-------|----------|------|-------|
| A    | 26/02/97 | Aggiornamento EAM 1472/1 e 1472/2       |      |      |                          |       | ESE 2358 |      |       |
| B    | 13/11/97 | Revisione schede                        |      |      |                          |       |          |      |       |
| C    | 23/04/98 | Spostato TA da W a V                    |      |      |                          |       |          |      |       |
| D    | 22/05/98 | Agg. EAM 1417/4, 1535/3, 1542/4, 1534/2 |      |      |                          |       |          |      |       |

| SCHEMA DELLE CONNESSIONI ELETTRICHE DEL |                          | GEFRAN |     |
|---|--------------------------|--------|-----|
| NAME:                                   | TPD32-400/470 -20+185-2B | RES.   | BAR |
|   | TPD32-500/600 -20+185-2B | SCH.   | RNC |
| DATE:                                   | 31-07-96                 | PAGE   | 1   |
|   |                          | OVER   | 4   |

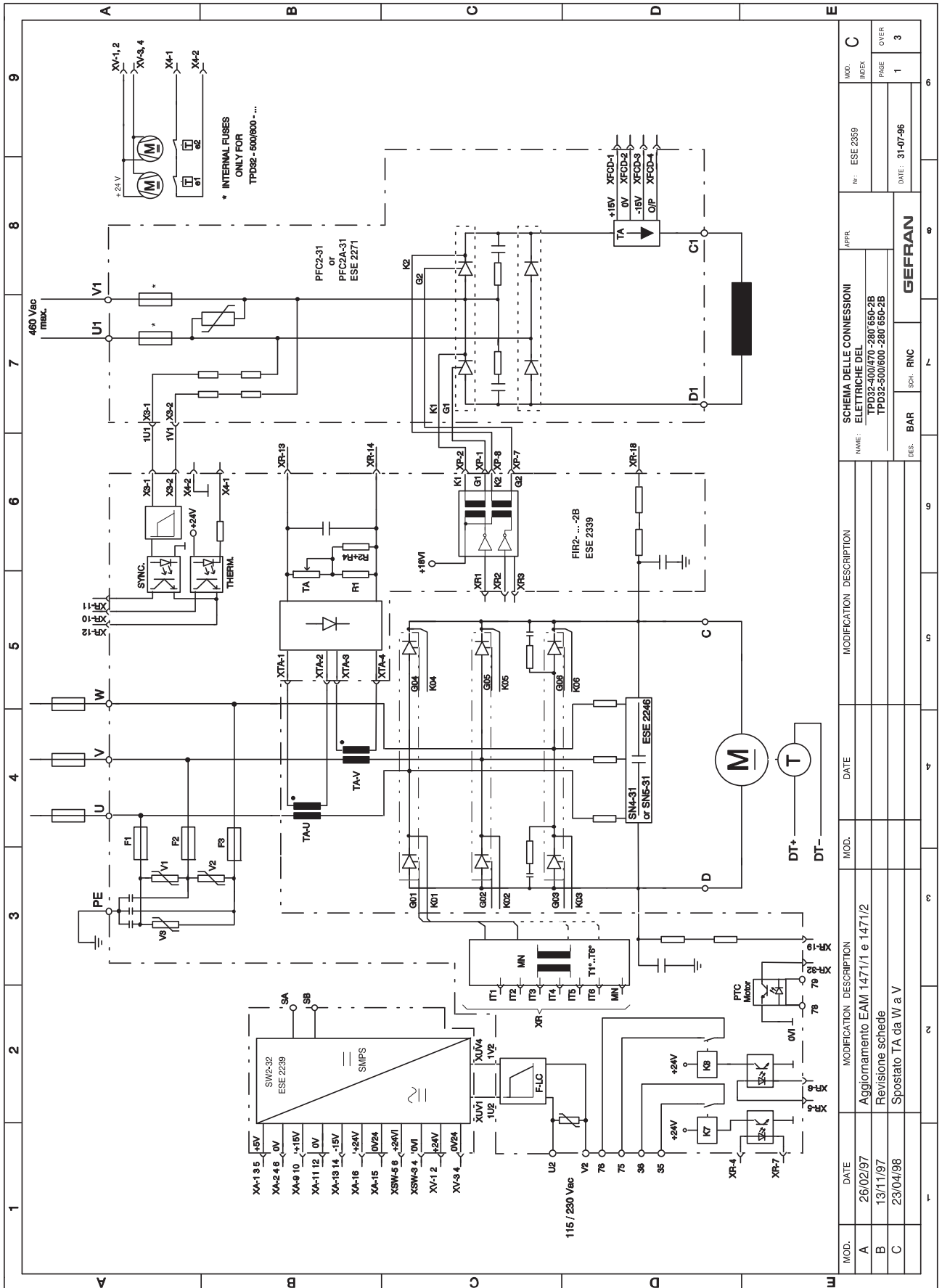

| MOD. | DATE     | MODIFICATION DESCRIPTION          | MOD. | DATE | MODIFICATION DESCRIPTION | APPR. | INDEX |
|------|----------|-----------------------------------|------|------|--------------------------|-------|-------|
| A    | 26/02/97 | Aggiornamento EAM 1471/1 e 1471/2 |      |      |                          |       |       |
| B    | 13/11/97 | Revisione schede                  |      |      |                          |       |       |
| C    | 23/04/98 | Spostato TA da W a V              |      |      |                          |       |       |

  

|   |     |          |     |
|---|-----|----------|-----|
| SCHEMA DELLE CONNESSIONI ELETTRICHE DEL |     | ESE 2359 |     |
| TPD32-400/470-280 650-2B                |     | INDEX    |     |
| TPD32-500/600-280 650-2B                |     | PAGE     |     |
| GEFRAN                                  |     | OVER     |     |
| DES.                                    | BAR | SCH.     | RNC |
| DATE: 31-07-96                          |     | 1        |     |
|   |     | 3        |     |

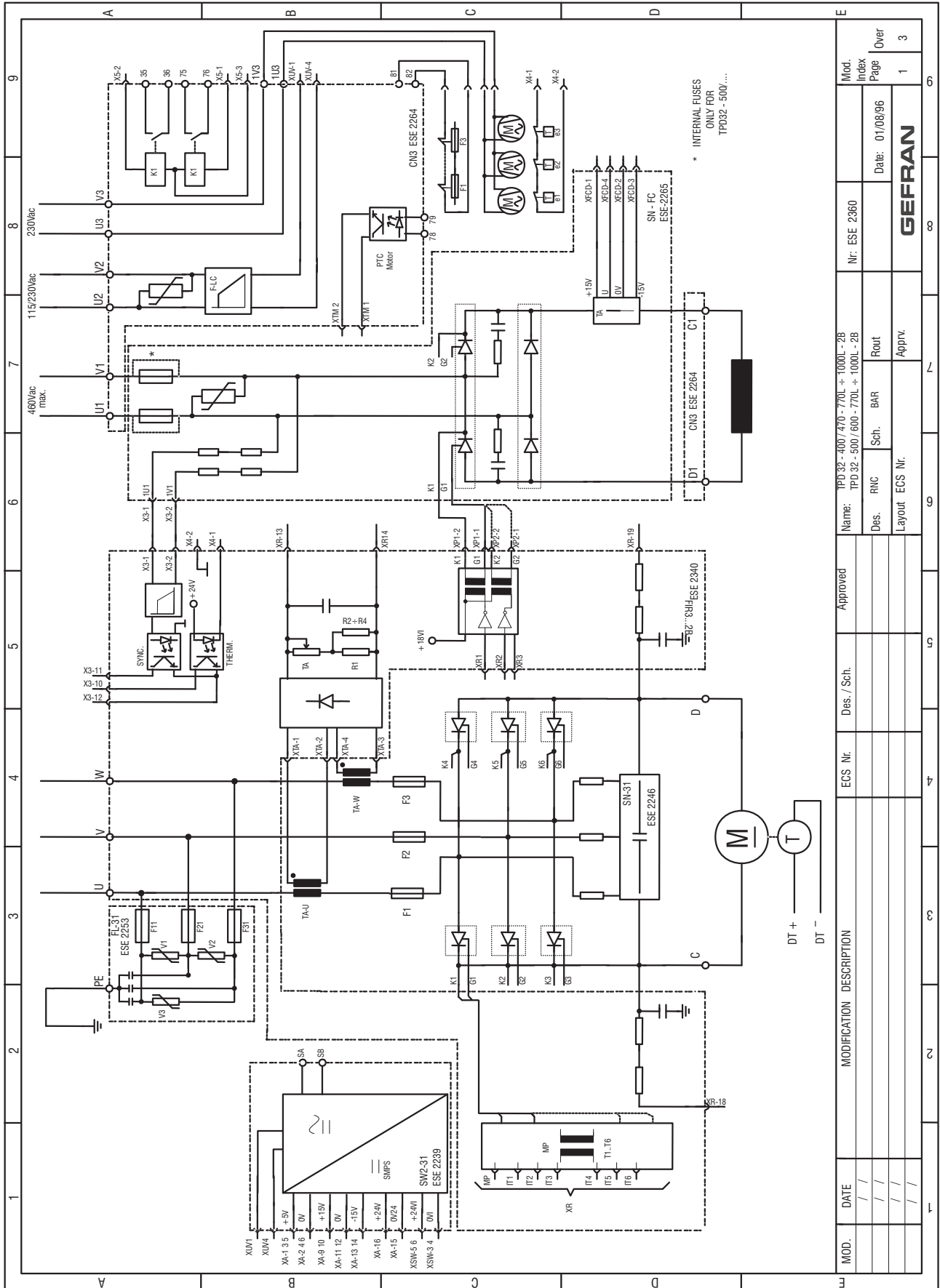

| MOD.          | DATE | MODIFICATION DESCRIPTION | ECS Nr. | Des. / Sch. | Approved | Name:                       | Nr:      | Mod. Index     |  |
|---------------|------|--------------------------|---------|-------------|----------|-----------------------------|----------|----------------|--|
|               |      |                          |         |             |          | TPD32-400/470-770L-1000L-2B | ESE 2360 | Page           |  |
|               |      |                          |         |             |          | TPD32-500/600-770L-1000L-2B |          | Over           |  |
|               |      |                          |         |             |          | Des. RNC                    | Sch. BAR | Date: 01/08/96 |  |
|               |      |                          |         |             |          | Layout ECS Nr.              | Apprv.   | 1 3            |  |
| <b>GEFRAN</b> |      |                          |         |             |          |                             |          |                |  |

### 9.3 REGULATION CARD

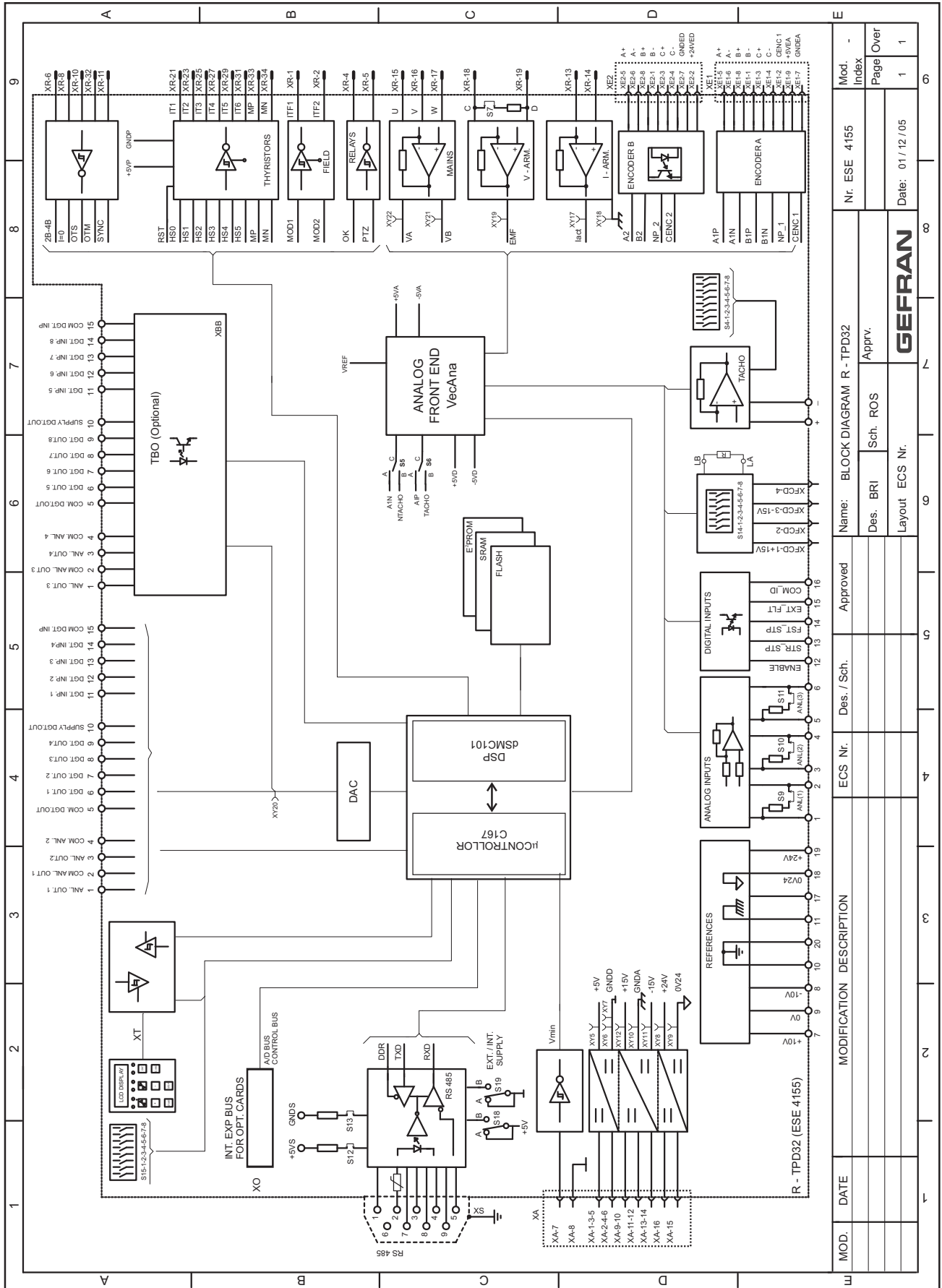





# 10 - PARAMETER LISTS

## 10.1 COMPLETE MAIN MENU LIST

*Explanation of tables:*

|   |   |
|---|---|
| White text on black background              | Menu/submenu  |
| White text on black background in brackets  | Function not accessible via keypad. The status of the corresponding parameter is only displayed.  |
| [FF] in the Parameter column                | Dimension based on the factor function  |
| “No.” column                                | <b>Parameter number (decimal). The value 2000H (= decimal 8192) must be added to the number given in the “No.” column in order to obtain the index to access the parameter via Bus , RS485 or Opt2. The parameters in the Drivecom group can be accessed using the format and index specified in the DRIVECOM power transmission profile (#21).</b> |
| “Format” column                             | Internal parameter format:<br>I= Integer (Example: I16 = Integer 16 bit)<br>U = Unsigned (Example: U32 = unsigned 32 bit)<br>Float = Floating point   |
| “Value” column                              | Minimum, maximum and factory parameter values.<br>If “S” the value is depending on the size of the device.  |
| “Keypad” column”                            | ✓ = Parameter available via keypad  |
| “RS485/BUS/Opt2-M” column<br>(low priority) | Parameter available via RS485, field Bus or via the APC200 manual communication (see the APC200 user manual)<br><br>The numbers indicate what has to be sent via interface line in order to set the single parameters.  |
| “Term.” column                              | Parameter addressable to one of the analog or digital input/output terminals.   |

“Opt2-A/”(Low priority)  
“PDC” (High priority)

Parameter available via APC200 asynchronous communication (see the APC200 user manual) and/or the Process Data Channel (PDC).

When using a field bus interface, parameters whose range is [min=0; max=1] can be assigned to either Virtual digital inputs (if W access code exists) and/or Virtual digital outputs (if R access code exists).

The numbers indicate what has to be sent via interface line in order to set the single parameters.

Letter in brackets in the “Term.” column Analog level to be applied to the terminal in order to start the single function.

IA, QA, ID, QD in the “Term.” column

The function can be accessed via a freely programmable analog or digital input or output.

IA = analog input

QA = analog output

ID = digital input

QD = digital output.

The eventually present number is the one by which the terminal is called.

H, L in the “Term.” column

Level of the terminal signals (H=high, L=low) which enables the single function.

R/W/Z/C

Access possibilities via the serial interface, Bus or Opt2 manual or asynchronous communication :

R = Read,

W = Write,

Z = Write only when drive disabled,

C=Command parameter (the writing of any value causes the execution of a command).

X · Pyy

The value of this parameter can correspond to min/max X times the value of the yy parameter.

**Note!**

The parameter number here indicated has to be intended as an offset value, that the user has always to add to the base value 2000H (= decimal 8192), in order to address parameters when a serial line/bus or the APC200 card are used. It also possible to accede to the DRIVECOM parameter with the DRIVECOM standard indexes.

\* When the parameter is accessed by Opt2-A/PDC the format is U16.

\*\* When the parameter is accessed by Opt2-A/PDC the format is I16.

\*\*\* When the parameter is accessed by Opt2-A/PDC the lower word of the parameter is considered.

| Parameter  | No.  | Format   | Value  |                    |                     |                     | Access via |                          |              |                |
|--|------|----------|--------|--------------------|---------------------|---------------------|------------|--------------------------|--------------|----------------|
|  |      |          | min    | max                | Factory American    | Factory European    | Key.       | RS485/<br>BUS/<br>Opt2-M | Term.        | Opt2-A/<br>PDC |
| Drive ready<br>Drive ready<br>Drive not ready                                  | 380  | U16      | 0      | 1                  | -                   | -                   | -          | R<br>1<br>0              | QD<br>H<br>L | R<br>1<br>0    |
| Quick stop<br>Quick stop<br>No Quick stop                                      | 343  | U16      | 0      | 1                  | No Quick stop       | No Quick stop       | -          | R/W<br>0<br>1            | -            | -              |
| Start/Stop<br>Start<br>Stop  | 315  | U16      | 0      | 1                  | Stop (0)            | Stop (0)            |            | R/W<br>1<br>0            | 13<br>H<br>L | R/W<br>1<br>0  |
| Fast stop<br>Fast Stop<br>No Fast Stop   | 316  | U16      | 0      | 1                  | No Fast Stop        | No Fast Stop        | -          | R/W<br>0<br>1            | 14<br>L<br>H | R/W<br>0<br>1  |
| <b>DRIVE STATUS</b>  |      |          |        |                    |                     |                     |            |                          |              |                |
| Ramp ref 1 [FF]  | 44   | I16      | -2 P45 | +2 P45             | 0                   | 0                   | ✓          | R/W                      | IA, QA       | R/W            |
| Enable drive<br>Enabled<br>Disabled  | 314  | U16      | 0      | 1                  | Disabled            | Disabled            | ✓          | R/W<br>1<br>0            | 12<br>H<br>L | R/W<br>1<br>0  |
| Start/Stop<br>Start<br>Stop  | 315  | U16      | 0      | 1                  | Stop (0)            | Stop (0)            | ✓          | R/W<br>1<br>0            | 13<br>H<br>L | R/W<br>1<br>0  |
| Output voltage [V]   | 233  | Float ** | 0      | 999                | -                   | -                   | ✓          | R                        | QA           | R              |
| Motor current [%]  | 199  | I16      | -250   | 250                | -                   | -                   | ✓          | R                        | QA           | R              |
| Actual spd (rpm)   | 122  | I16      | -8192  | +8192              | -                   | -                   | ✓          | R                        | QA           | R              |
| Speed ref (rpm)  | 118  | I16      | -32768 | +32767             | -                   | -                   | ✓          | R                        | QA           | R              |
| Output power [kW]  | 1052 | Float    | 0.01   | 9999.99            | -                   | -                   | ✓          | R                        | -            | -              |
| Flux current (A)   | 351  | Float    | 0.1    | 99.9               | S                   | S                   | ✓          | R                        | -            | -              |
| Mains voltage [V]  | 466  | U16      | 0      | 999                | -                   | -                   | ✓          | R                        | -            | -              |
| Digital I/Q  |      |          |        |                    | -                   | -                   | ✓          | -                        | -            | -              |
| <b>START UP</b>  |      |          |        |                    |                     |                     |            |                          |              |                |
| Speed base value [FF]  | 45   | U32***   | 1      | 16383              | 1500                | 1500                | ✓          | R/Z                      | -            | R              |
| Nom flux curr [A]  | 374  | Float    | 0.5    | 70.0               | S                   | S                   | ✓          | R/Z                      | -            | -              |
| Speed-0 f weak<br>ON (Enabled)<br>OFF (Disabled)                               | 499  | U16      | 0      | 1                  | 0                   | 0                   | ✓          | R/W<br>1<br>0            | -            | -              |
| Acc delta speed [FF]   | 21   | U32      | 0      | 2 <sup>32</sup> -1 | 100                 | 100                 | ✓          | R/W                      | -            | -              |
| Acc delta time [s]   | 22   | U16      | 0      | 65535              | 1                   | 1                   | ✓          | R/W                      | -            | -              |
| Dec delta speed [FF]   | 29   | U32      | 0      | 2 <sup>32</sup> -1 | 100                 | 100                 | ✓          | R/W                      | -            | -              |
| Dec delta time [s]   | 30   | U16      | 0      | 65535              | 1                   | 1                   | ✓          | R/W                      | -            | -              |
| <b>START UP \ Motor data</b>   |      |          |        |                    |                     |                     |            |                          |              |                |
| Motor nom flux   | 280  | Float    | 0.0    | P374               | P374                | P374                | ✓          | R/Z                      | -            | -              |
| Flux reg mode<br>Constant current<br>Voltage control<br>External control (OFF) | 469  | U16      | 0      | 2                  | Const. current<br>0 | Const. current<br>0 | ✓          | R/Z<br>0<br>1<br>2       | -            | -              |
| Full load curr [A]   | 179  | Float    | 0.1    | IdAN               | IdAN                | IdAN                | ✓          | R/Z                      | -            | -              |
| Motor max speed [rpm]  | 162  | Float *  | 0      | 6553               | 1500                | 1500                | ✓          | R/Z                      | -            | R              |
| Max out voltage [V]  | 175  | Float    | 20     | 999                | 400                 | 400                 | ✓          | R/Z                      | -            | -              |
| Flux weak speed [%]  | 456  | U16      | 0      | 100                | 100                 | 100                 | ✓          | R/Z                      | -            | R              |

| Parameter                        | No.  | Format  | Value  |                    |                  |                  | Access via |                          |       |                |
|----------------------------------|------|---------|--------|--------------------|------------------|------------------|------------|--------------------------|-------|----------------|
|                                  |      |         | min    | max                | Factory American | Factory European | Keyp.      | RS485/<br>BUS/<br>Opt2-M | Term. | Opt2-A/<br>PDC |
| <b>START UP \ Limits</b>         |      |         |        |                    |                  |                  |            |                          |       |                |
| T current lim [%]                | 7    | U16     | 0      | 200                | 150              | 150              | ✓          | R/W                      | IA    | R/W            |
| Flux current min [%]             | 468  | U16     | 0      | P467               | 5                | 5                | ✓          | R/W                      | -     | ----           |
| Flux current max [%]             | 467  | U16     | P468   | 100                | 100              | 100              | ✓          | R/W                      | -     | R/W            |
| Speed min amount [FF]            | 1    | U32     | 0      | 2 <sup>32</sup> -1 | 0                | 0                | ✓          | R/Z                      | -     | -              |
| Speed max amount [FF]            | 2    | U32     | 0      | 2 <sup>32</sup> -1 | 5000             | 5000             | ✓          | R/Z                      | -     | -              |
| <b>START UP \ Speed feedback</b> |      |         |        |                    |                  |                  |            |                          |       |                |
| Speed fbk sel                    | 414  | U16     | 0      | 3                  | 1                | 1                | ✓          | R/Z                      | -     | R              |
| Encoder 1                        |      |         |        |                    |                  |                  |            | 0                        |       |                |
| Encoder 2                        |      |         |        |                    |                  |                  |            | 1                        |       |                |
| Tacho                            |      |         |        |                    |                  |                  |            | 2                        |       |                |
| Armature                         |      |         |        |                    |                  |                  |            | 3                        |       |                |
| Tacho scale                      | 562  | Float   | 0.90   | 3.00               | 1.00             | 1.00             | ✓          | R/W                      | -     | -              |
| Speed offset                     | 563  | Float   | -20.00 | +20.00             | 0.00             | 0.00             | ✓          | R/W                      | -     | -              |
| Encoder 2 pulses                 | 169  | Float * | 600    | 9999               | 1024             | 1024             | ✓          | R/Z                      | -     | R              |
| Enable fbk contr                 | 457  | U16     | 0      | 1                  | Enabled (1)      | Enabled (1)      | ✓          | R/Z                      | -     | -              |
| Enabled                          |      |         |        |                    |                  |                  |            | 1                        |       |                |
| Disabled                         |      |         |        |                    |                  |                  |            | 0                        |       |                |
| Refresh enc 2                    | 652  | U16     | 0      | 1                  | 0                | 0                | ✓          | R/W                      | -     | -              |
| Enabled                          |      |         |        |                    |                  |                  |            | 1                        |       |                |
| Disabled                         |      |         |        |                    |                  |                  |            | 0                        |       |                |
| <b>START UP \ Alarms</b>         |      |         |        |                    |                  |                  |            |                          |       |                |
| Undervolt thr [V]                | 481  | U16     | 0      | 1000               | 230              | 230              | ✓          | R/W                      | -     | -              |
| Overcurrent thr [%]              | 584  | U16     | 0      | 200                | 160              | 160              | ✓          | R/W                      | -     | -              |
| <b>START UP \ Overload contr</b> |      |         |        |                    |                  |                  |            |                          |       |                |
| Enable overload                  | 309  | I16     | 0      | 1                  | Enabled          | Disabled         | ✓          | R/Z                      | -     | -              |
| Enabled                          |      |         |        |                    |                  |                  |            | 1                        |       |                |
| Disabled                         |      |         |        |                    |                  |                  |            | 0                        |       |                |
| Overload mode                    | 318  | U16     | 0      | 4                  | I2t Motor        | Curr limited     | ✓          | R/W                      | -     | -              |
| Curr limited                     |      |         |        |                    |                  |                  |            | 0                        |       |                |
| Curr not limited                 |      |         |        |                    |                  |                  |            | 1                        |       |                |
| I2t Motor                        |      |         |        |                    |                  |                  |            | 2                        |       |                |
| I2t Drive                        |      |         |        |                    |                  |                  |            | 3                        |       |                |
| I2t Motor & Drv                  |      |         |        |                    |                  |                  |            | 4                        |       |                |
| Overload current [%]             | 312  | U16     | P313   | 200                | 150              | 100              | ✓          | R/W                      | -     | -              |
| Base current [%]                 | 313  | U16     | 0      | P312 < 100         | 100              | 80               | ✓          | R/W                      | -     | -              |
| Overload time [s]                | 310  | U16     | 0      | 65535              | 60               | 30               | ✓          | R/W                      | -     | -              |
| Motor ovrlld preal.              | 1289 | U16     | 0      | 1                  | -                | -                | ✓          | R                        | -     | -              |
| Motor I2t accum                  | 655  | Float   | 0,00   | 100,00             | -                | -                | ✓          | R                        | -     | -              |
| Drive ovrlld preal.              | 1438 | U16     | 0      | 1                  | -                | -                | ✓          | R                        | -     | -              |
| Drive I2t accum                  | 1439 | FLOAT   | 0,00   | 100,00             | -                | -                | ✓          | R                        | -     | -              |
| Pause time [s]                   | 311  | U16     | 0      | 65535              | 540              | 300              | ✓          | R/W                      | -     | -              |
| Overld available                 | 406  | U16     | 0      | 1                  | -                | -                | -          | R                        | QD    | R              |
| Overload not possible            |      |         |        |                    |                  |                  |            | 0                        | L     | 0              |
| Overload possible                |      |         |        |                    |                  |                  |            | 1                        | H     | 1              |
| Overload state                   | 407  | U16     | 0      | 1                  | -                | -                | -          | R                        | QD    | R              |
| Current limit value              |      |         |        |                    |                  |                  |            | 0                        | L     | 0              |
| Current > limit value            |      |         |        |                    |                  |                  |            | 1                        | H     | 1              |

| Parameter  | No. | Format | Value   |        |                   |                   | Access via |                          |       |                |
|--|-----|--------|---------|--------|-------------------|-------------------|------------|--------------------------|-------|----------------|
|  |     |        | min     | max    | Factory American  | Factory European  | Keyp.      | RS485/<br>BUS/<br>Opt2-M | Term. | Opt2-A/<br>PDC |
| <b>START UP \ Analog inputs \ Analog input 1</b> |     |        |         |        |                   |                   |            |                          |       |                |
| Select input 1                                   | 70  | U16    | 0       | 32     | Ramp ref<br>1 (4) | Ramp ref<br>1 (4) | ✓          | R/Z                      | -     | -              |
| OFF  |     |        |         |        |                   |                   |            | 0                        |       |                |
| Jog reference                                    |     |        |         |        |                   |                   |            | 1                        |       |                |
| Speed ref 1                                      |     |        |         |        |                   |                   |            | 2                        |       |                |
| Speed ref 2                                      |     |        |         |        |                   |                   |            | 3                        |       |                |
| Ramp ref 1                                       |     |        |         |        |                   |                   |            | 4                        |       |                |
| Ramp ref 2                                       |     |        |         |        |                   |                   |            | 5                        |       |                |
| T current ref 1                                  |     |        |         |        |                   |                   |            | 6                        |       |                |
| T current ref 2                                  |     |        |         |        |                   |                   |            | 7                        |       |                |
| Adap reference                                   |     |        |         |        |                   |                   |            | 8                        |       |                |
| T current limit                                  |     |        |         |        |                   |                   |            | 9                        |       |                |
| T current lim +                                  |     |        |         |        |                   |                   |            | 10                       |       |                |
| T current lim -                                  |     |        |         |        |                   |                   |            | 11                       |       |                |
| Pad 0  |     |        |         |        |                   |                   |            | 12                       |       |                |
| Pad 1  |     |        |         |        |                   |                   |            | 13                       |       |                |
| Pad 2  |     |        |         |        |                   |                   |            | 14                       |       |                |
| Pad 3  |     |        |         |        |                   |                   |            | 15                       |       |                |
| Load comp  |     |        |         |        |                   |                   |            | 19                       |       |                |
| PID offset 0                                     |     |        |         |        |                   |                   |            | 21                       |       |                |
| PI central v3                                    |     |        |         |        |                   |                   |            | 22                       |       |                |
| PID feed-back                                    |     |        |         |        |                   |                   |            | 23                       |       |                |
| Flux current max                                 |     |        |         |        |                   |                   |            | 25                       |       |                |
| Out vlt level                                    |     |        |         |        |                   |                   |            | 26                       |       |                |
| Speed ratio                                      |     |        |         |        |                   |                   |            | 28                       |       |                |
| Tension red                                      |     |        |         |        |                   |                   |            | 29                       |       |                |
| Tension ref                                      |     |        |         |        |                   |                   |            | 30                       |       |                |
| Preset 3   |     |        |         |        |                   |                   |            | 31                       |       |                |
| Brake Ref  |     |        |         |        |                   |                   |            | 32                       |       |                |
| Scale input 1                                    | 72  | Float  | -10000  | 10.000 | 1.000             | 1.000             | ✓          | R/W                      | -     | -              |
| Auto tune inp 1                                  | 259 | U16    |         |        |                   |                   | ✓          | C/W                      | -     | -              |
| Auto tune  |     |        |         |        |                   |                   |            | 1                        |       |                |
| Offset input 1                                   | 74  | I16    | -32768  | +32767 | 0                 | 0                 | ✓          | R/W                      | -     | -              |
| <b>START UP \ Analog inputs \ Analog input 2</b> |     |        |         |        |                   |                   |            |                          |       |                |
| Select input 2<br>(Select like Input 1)          | 75  | U16    | 0       | 32     | OFF (0)           | OFF (0)           | ✓          | R/Z                      | -     | -              |
| Scale input 2                                    | 77  | Float  | -10.000 | 10.000 | 1.000             | 1.000             | ✓          | R/W                      | -     | -              |
| Auto tune inp 2                                  | 260 | U16    |         |        |                   |                   | ✓          | C/W                      | -     | -              |
| Auto tune  |     |        |         |        |                   |                   |            | 1                        |       |                |
| Offset input 2                                   | 79  | I16    | -32768  | +32767 | 0                 | 0                 | ✓          | R/W                      | -     | -              |
| <b>START UP \ Analog inputs \ Analog input 3</b> |     |        |         |        |                   |                   |            |                          |       |                |
| Select input 3<br>(Select like Input 1)          | 80  | U16    | 0       | 32     | OFF (0)           | OFF (0)           | ✓          | R/Z                      | -     | -              |
| Scale input 3                                    | 82  | Float  | -10.000 | 10.000 | 1.000             | 1.000             | ✓          | R/W                      | -     | -              |
| Auto tune inp 3                                  | 261 | U16    |         |        |                   |                   | ✓          | C/W                      | -     | -              |
| Auto tune  |     |        |         |        |                   |                   |            | 1                        |       |                |
| Offset input 3                                   | 84  | I16    | -32768  | +32767 | 0                 | 0                 | ✓          | R/W                      | -     | -              |
| <b>START UP</b>                                  |     |        |         |        |                   |                   |            |                          |       |                |
| R&L Search                                       | 452 | U16    | 0       | 1      | OFF               | OFF               | ✓          | R/Z                      | -     | -              |
| OFF  |     |        |         |        |                   |                   |            | 0                        |       |                |
| ON   |     |        |         |        |                   |                   |            | 1                        |       |                |
| Enable drive                                     | 314 | U16    | 0       | 1      | Disabled          | Disabled          | ✓          | R/W                      | 12    | R/W            |
| Enabled  |     |        |         |        |                   |                   |            | 1                        | H     | 1              |
| Disabled   |     |        |         |        |                   |                   |            | 0                        | L     | 0              |
| Start/Stop                                       | 315 | U16    | 0       | 1      | Stop<br>(0)       | Stop<br>(0)       | ✓          | R/W                      | 13    | R/W            |
| Start  |     |        |         |        |                   |                   |            | 1                        | H     | 1              |
| Stop   |     |        |         |        |                   |                   |            | 0                        | L     | 0              |

| Parameter                         | No.  | Format | Value |         |                   |                   | Access via |                          |       |                |
|-----------------------------------|------|--------|-------|---------|-------------------|-------------------|------------|--------------------------|-------|----------------|
|                                   |      |        | min   | max     | Factory American  | Factory European  | Keyp.      | RS485/<br>BUS/<br>Opt2-M | Term. | Opt2-A/<br>PDC |
| <b>START UP \ Speed self tune</b> |      |        |       |         |                   |                   |            |                          |       |                |
| Fwd-Rev spd tune                  | 1029 | U16    | 1     | 2       | Fwd Direction (1) | Fwd Direction (1) | ✓          | R/Z                      | -     | -              |
| Fwd direction                     |      |        |       |         |                   |                   |            | 1                        |       |                |
| Rev direction                     |      |        |       |         |                   |                   |            | 2                        |       |                |
| Test T curr lim [%]               | 1048 | U16    | 0     | S       | 20                | 20                | ✓          | R/Z                      | -     | -              |
| Start                             | 1027 | U16    | 0     | 65535   | -                 | -                 | ✓          | C                        | -     | -              |
| Inertia [kg*m*m*]                 | 1014 | Float  | 0.001 | 999.999 | S                 | S                 | ✓          | R/W                      | -     | -              |
| Inertia Nw [kg*m*m*]              | 1030 | Float  | 0.001 | 999.999 | -                 | -                 | ✓          | R                        | -     | -              |
| Friction [N*m]                    | 1015 | Float  | 0.000 | 99.999  | S                 | S                 | ✓          | R/W                      | -     | -              |
| Friction Nw [N*m]                 | 1031 | Float  | 0.000 | 99.99   | -                 | -                 | ✓          | R                        | -     | -              |
| Speed P [%]                       | 87   | Float  | 0.00  | 100.00  | S                 | S                 | ✓          | R/W                      | -     | -              |
| Speed P Nw [%]                    | 1032 | Float  | 0.00  | 100.00  | -                 | -                 | ✓          | R                        | -     | -              |
| Speed I [%]                       | 88   | Float  | 0.00  | 100.00  | S                 | S                 | ✓          | R/W                      | -     | -              |
| Speed I Nw [%]                    | 1033 | Float  | 0.00  | 100.00  | -                 | -                 | ✓          | R                        | -     | -              |
| Take val                          | 1028 | U16    | 0     | 65535   | -                 | -                 | ✓          | Z/C                      | -     | -              |
| <b>START UP</b>                   |      |        |       |         |                   |                   |            |                          |       |                |
| Main commands                     | 252  | U16    | 0     | 1       | Term (0)          | Term (0)          | ✓          | R/Z                      | -     | -              |
| Terminals                         |      |        |       |         |                   |                   |            | 0                        |       |                |
| Digitals                          |      |        |       |         |                   |                   |            | 1                        |       |                |
| Control mode                      | 253  | U16    | 0     | 1       | Local (0)         | Local (0)         | ✓          | R/Z                      | -     | -              |
| Local                             |      |        |       |         |                   |                   |            | 0                        |       |                |
| Bus                               |      |        |       |         |                   |                   |            | 1                        |       |                |
| Save parameters                   | 256  | U16    |       |         |                   |                   | ✓          | C/W                      | -     | -              |
|                                   |      |        |       |         |                   |                   |            | (1)                      |       |                |
| <b>TUNING</b>                     |      |        |       |         |                   |                   |            |                          |       |                |
| R&L Search                        | 452  | U16    | 0     | 1       | OFF               | OFF               | ✓          | R/Z                      | -     | -              |
| OFF                               |      |        |       |         |                   |                   |            | 0                        |       |                |
| ON                                |      |        |       |         |                   |                   |            | 1                        |       |                |
| Enable drive                      | 314  | U16    | 0     | 1       | Disabled          | Disabled          | ✓          | R/W                      | 12    | R/W            |
| Enabled                           |      |        |       |         |                   |                   |            | 1                        | H     | 1              |
| Disabled                          |      |        |       |         |                   |                   |            | 0                        | L     | 0              |
| Start/Stop                        | 315  | U16    | 0     | 1       | Stop (0)          | Stop (0)          | ✓          | R/W                      | 13    | R/W            |
| Start                             |      |        |       |         |                   |                   |            | 1                        | H     | 1              |
| Stop                              |      |        |       |         |                   |                   |            | 0                        | L     | 0              |
| <b>TUNING \ Speed self tune</b>   |      |        |       |         |                   |                   |            |                          |       |                |
| Fwd-Rev spd tune                  | 1029 | U16    | 1     | 2       | Fwd Direction -1  | Fwd Direction -1  | ✓          | R/Z                      | -     | -              |
| Fwd direction                     |      |        |       |         |                   |                   |            | 1                        |       |                |
| Rev direction                     |      |        |       |         |                   |                   |            | 2                        |       |                |
| Test T curr lim [%]               | 1048 | U16    | 0     | S       | 20                | 20                | ✓          | R/Z                      | -     | -              |
| Start                             | 1027 | U16    | 0     | 65535   | -                 | -                 | ✓          | C                        | -     | -              |
| Inertia [kg*m*m*]                 | 1014 | Float  | 0.001 | 999.999 | S                 | S                 | ✓          | R/W                      | -     | -              |
| Inertia Nw [kg*m*m*]              | 1030 | Float  | 0.001 | 999.999 | -                 | -                 | ✓          | R                        | -     | -              |
| Friction [N*m]                    | 1015 | Float  | 0.000 | 99.999  | S                 | S                 | ✓          | R/W                      | -     | -              |
| Friction Nw [N*m]                 | 1031 | Float  | 0.00  | 99.99   | -                 | -                 | ✓          | R                        | -     | -              |
| Speed P [%]                       | 87   | Float  | 0.00  | 100.00  | S                 | S                 | ✓          | R/W                      | -     | -              |
| Speed P Nw [%]                    | 1032 | Float  | 0.00  | 100.00  | -                 | -                 | ✓          | R                        | -     | -              |
| Speed I [%]                       | 88   | Float  | 0.00  | 100.00  | S                 | S                 | ✓          | R/W                      | -     | -              |
| Speed I Nw [%]                    | 1033 | Float  | 0.00  | 100.00  | -                 | -                 | ✓          | R                        | -     | -              |
| Take val                          | 1028 | U16    | 0     | 65535   | -                 | -                 | ✓          | Z/C                      | -     | -              |

| Parameter  | No.  | Format   | Value  |         |                  |                  | Access via |                          |       |                |
|--|------|----------|--------|---------|------------------|------------------|------------|--------------------------|-------|----------------|
|  |      |          | min    | max     | Factory American | Factory European | Keyp.      | RS485/<br>BUS/<br>Opt2-M | Term. | Opt2-A/<br>PDC |
| <b>TUNING</b>  |      |          |        |         |                  |                  |            |                          |       |                |
| Speed P [%]  | 87   | Float    | 0.00   | 100.00  | S                | S                | ✓          | R/W                      | -     | -              |
| Speed I [%]  | 88   | Float    | 0.00   | 100.00  | S                | S                | ✓          | R/W                      | -     | -              |
| Prop filter [ms]   | 444  | U16      | 0      | 1000    | 0                | 0                | ✓          | R/W                      | -     | -              |
| Flux P [%]   | 91   | Float    | 0.00   | 100.00  | 2.00             | 2.00             | ✓          | R/W                      | -     | -              |
| Flux I [%]   | 92   | Float    | 0.00   | 100.00  | 1.00             | 1.00             | ✓          | R/W                      | -     | -              |
| Voltage P [%]  | 493  | Float    | 0.00   | 100.00  | 30.00            | 30.00            | ✓          | R/W                      | -     | -              |
| Voltage I [%]  | 494  | Float    | 0.00   | 100.00  | 40.00            | 40.00            | ✓          | R/W                      | -     | -              |
| Save parameters  | 256  | U16      |        |         |                  |                  | ✓          | C/W<br>(1)               | -     | -              |
| <b>MONITOR</b>   |      |          |        |         |                  |                  |            |                          |       |                |
| Enable drive   | 314  | U16      | 0      | 1       | Disabled         | Disabled         | ✓          | R/W                      | 12    | R/W            |
| Enabled<br>Disabled                                      |      |          |        |         |                  |                  |            |                          |       |                |
| Start/Stop   | 315  | U16      | 0      | 1       | Stop<br>(0)      | Stop<br>(0)      | ✓          | R/W                      | 13    | R/W            |
| Start<br>Stop  |      |          |        |         |                  |                  |            |                          |       |                |
| <b>MONITOR \ Measurements \ Speed \ Speed in DRC [ ]</b> |      |          |        |         |                  |                  |            |                          |       |                |
| Ramp ref (d) [FF]  | 109  | I16      | -32768 | +32767  | -                | -                | ✓          | R                        | -     | R              |
| Ramp output (d) [FF]                                     | 112  | I16      | -32768 | +32767  | -                | -                | ✓          | R                        | -     | R              |
| Speed ref (d) [FF]                                       | 115  | I16      | -32768 | +32767  | -                | -                | ✓          | R                        | -     | R              |
| Actual spd (d) [FF]                                      | 119  | I16      | -32768 | +32767  | -                | -                | ✓          | R                        | -     | R              |
| F act spd (d) [FF]                                       | 925  | I16      | -32768 | +32767  | -                | -                | ✓          | R                        | -     | R              |
| Act spd filter [s]                                       | 923  | Float    | 0.001  | 1.000   | 0.100            | 0.100            | ✓          | R/W                      | -     | -              |
| <b>MONITOR \ Measurements \ Speed \ Speed in rpm</b>     |      |          |        |         |                  |                  |            |                          |       |                |
| Ramp ref (rpm)   | 110  | I16      | -32768 | +32767  | -                | -                | ✓          | R                        | QA    | R              |
| Ramp outp (rpm)  | 113  | I16      | -32768 | +32767  | -                | -                | ✓          | R                        | QA    | R              |
| Speed ref (rpm)  | 118  | I16      | -32768 | +32767  | -                | -                | ✓          | R                        | QA    | R              |
| Actual spd (rpm)   | 122  | I16      | -8192  | +8192   | -                | -                | ✓          | R                        | QA    | R              |
| Enc 1 speed (rpm)  | 427  | I16      | -8192  | +8192   | -                | -                | ✓          | R                        |       | R              |
| Enc 2 speed (rpm)  | 420  | I16      | -8192  | +8192   | -                | -                | ✓          | R                        |       | R              |
| F act spd (rpm)  | 924  | I16      | -32768 | +32767  | -                | -                | ✓          | R                        | QA    | R              |
| Act spd filter [s]                                       | 923  | Float    | 0.001  | 1.000   | 0.100            | 0.100            | ✓          | R/W                      | -     | -              |
| <b>MONITOR \ Measurements \ Speed \ Speed in %</b>       |      |          |        |         |                  |                  |            |                          |       |                |
| Ramp ref (%)   | 111  | Float    | -200.0 | +200.0  | -                | -                | ✓          | R                        | -     | -              |
| Ramp output (%)  | 114  | Float    | -200.0 | +200.0  | -                | -                | ✓          | R                        | -     | -              |
| Speed ref (%)  | 117  | Float    | -200.0 | +200.0  | -                | -                | ✓          | R                        | -     | -              |
| Actual spd (%)   | 121  | Float    | -200.0 | +200.0  | -                | -                | ✓          | R                        | -     | -              |
| <b>MONITOR \ Measurements</b>                            |      |          |        |         |                  |                  |            |                          |       |                |
| Mains voltage [V]  | 466  | U16      | 0      | 999     | -                | -                | ✓          | R                        | -     | -              |
| Mains frequency [Hz]                                     | 588  | Float    | 0.0    | 70.0    | -                | -                | ✓          | R                        | -     | -              |
| Output power [Kw]  | 1052 | Float    | 0.01   | 9999.99 | -                | -                | ✓          | R                        | -     | -              |
| Output voltage [V]                                       | 233  | Float ** | 0      | 999     | -                | -                | ✓          | R                        | QA    | R              |
| Motor current [%]  | 199  | I16      | -250   | 250     | -                | -                | ✓          | R                        | QA    | R              |
| F T curr (%)   | 928  | I16      | -500   | +500    | -                | -                | ✓          | R                        | QA    | R              |
| T curr filter [s]  | 926  | Float    | 0.001  | 0.250   | 0.100            | 0.100            | ✓          | R/W                      | -     | -              |
| T current ref [%]  | 41   | I16      | -200   | +200    | -                | -                | ✓          | R                        | QA    | R              |
| Flux reference [%]                                       | 500  | Float*   | 0.0    | 100.0   | -                | -                | ✓          | R                        | QA    | -              |
| Flux current [%]   | 234  | Float *  | 0.0    | 100.0   | -                | -                | ✓          | R                        | QA    | R              |
| Flux current (A)   | 351  | Float    | 0.1    | 99.9    | S                | S                | ✓          | R                        | -     | -              |

| Parameter  | No. | Format | Value  |                    |                  |                  | Access via |                          |        |                |
|--|-----|--------|--------|--------------------|------------------|------------------|------------|--------------------------|--------|----------------|
|  |     |        | min    | max                | Factory American | Factory European | Key.       | RS485/<br>BUS/<br>Opt2-M | Term.  | Opt2-A/<br>PDC |
| <b>MONITOR \ I/O</b>                             |     |        |        |                    |                  |                  |            |                          |        |                |
| Digital I/Q                                      |     |        |        |                    | -                | -                | ✓          | -                        | -      | -              |
| Dig input term                                   | 564 | U16    | 0      | 65535              | -                | -                | -          | R                        | -      | R              |
| Dig input term 1                                 | 565 | U16    | 0      | 1                  | -                | -                | -          | R                        | -      | R              |
| Dig input term 2                                 | 566 | U16    | 0      | 1                  | -                | -                | -          | R                        | -      | R              |
| Dig input term 3                                 | 567 | U16    | 0      | 1                  | -                | -                | -          | R                        | -      | R              |
| Dig input term 4                                 | 568 | U16    | 0      | 1                  | -                | -                | -          | R                        | -      | R              |
| Dig input term 5                                 | 569 | U16    | 0      | 1                  | -                | -                | -          | R                        | -      | R              |
| Dig input term 6                                 | 570 | U16    | 0      | 1                  | -                | -                | -          | R                        | -      | R              |
| Dig input term 7                                 | 571 | U16    | 0      | 1                  | -                | -                | -          | R                        | -      | R              |
| Dig input term 8                                 | 572 | U16    | 0      | 1                  | -                | -                | -          | R                        | -      | R              |
| Dig input term 9                                 | 573 | U16    | 0      | 1                  | -                | -                | -          | R                        | -      | R              |
| Dig input term 10                                | 574 | U16    | 0      | 1                  | -                | -                | -          | R                        | -      | R              |
| Dig input term 11                                | 575 | U16    | 0      | 1                  | -                | -                | -          | R                        | -      | R              |
| Dig input term 12                                | 576 | U16    | 0      | 1                  | -                | -                | -          | R                        | -      | R              |
| Dig input term 15                                | 579 | U16    | 0      | 1                  | -                | -                | -          | R                        | -      | R              |
| Dig input term 16                                | 580 | U16    | 0      | 1                  | -                | -                | -          | R                        | -      | R              |
| Dig output term                                  | 581 | U16    | 0      | 65535              | -                | -                | -          | R                        | -      | R              |
| Virtual dig inp                                  | 582 | U16    | 0      | 65535              | -                | -                | ✓          | R                        | -      | -              |
| Virtual dig out                                  | 583 | U16    | 0      | 65535              | -                | -                | ✓          | R                        | -      | -              |
| <b>INPUT VARIABLES \ Ramp ref \ Ramp ref 1</b>   |     |        |        |                    |                  |                  |            |                          |        |                |
| Ramp ref 1 [FF]                                  | 44  | I16    | -2 P45 | +2 P45             | 0                | 0                | ✓          | R/W                      | IA, QA | R/W            |
| Ramp ref 1 (%)                                   | 47  | Float  | -200.0 | +200.0             | 0.0              | 0.0              | ✓          | R/W                      | -      | -              |
| <b>INPUT VARIABLES \ Ramp ref \ Ramp ref 2</b>   |     |        |        |                    |                  |                  |            |                          |        |                |
| Ramp ref 2 [FF]                                  | 48  | I16    | -2 P45 | +2 P45             | 0                | 0                | ✓          | R/W                      | IA, QA | R/W            |
| Ramp ref 2 (%)                                   | 49  | Float  | -200.0 | +200.0             | 0.0              | 0.0              | ✓          | R/W                      | -      | -              |
| <b>INPUT VARIABLES \ Speed ref \ Speed ref 1</b> |     |        |        |                    |                  |                  |            |                          |        |                |
| Speed ref 1 [FF]                                 | 42  | I16    | -2 P45 | +2 P45             | 0                | 0                | ✓          | R/W                      | IA, QA | R/W            |
| Speed ref 1 (%)                                  | 378 | Float  | -200.0 | +200.0             | 0                | 0                | ✓          | R/W                      | -      | -              |
| <b>INPUT VARIABLES \ Speed ref \ Speed ref 2</b> |     |        |        |                    |                  |                  |            |                          |        |                |
| Speed ref 2 [FF]                                 | 43  | I16    | -2 P45 | +2 P45             | 0                | 0                | ✓          | R/W                      | IA, QA | R/W            |
| Speed Ref 2 (%)                                  | 379 | Float  | -200.0 | +200.0             | 0                | 0                | ✓          | R/W                      | -      | -              |
| <b>INPUT VARIABLES \ T current ref</b>           |     |        |        |                    |                  |                  |            |                          |        |                |
| T current ref 1 [%]                              | 39  | I16    | -200   | +200<br>see 6.4.3  | 0                | 0                | ✓          | R/W                      | IA, QA | R/W            |
| T current ref 2 [%]                              | 40  | I16    | -200   | +200               | 0.00             | 0.00             | ✓          | R/W                      | IA, QA | -              |
| <b>LIMITS \ Speed limits \ Speed amount</b>      |     |        |        |                    |                  |                  |            |                          |        |                |
| Speed min amount [FF]                            | 1   | U32    | 0      | 2 <sup>32</sup> -1 | 0                | 0                | ✓          | R/Z                      | -      | -              |
| Speed max amount [FF]                            | 2   | U32    | 0      | 2 <sup>32</sup> -1 | 5000             | 5000             | ✓          | R/Z                      | -      | -              |
| <b>LIMITS \ Speed limits \ Speed min/max</b>     |     |        |        |                    |                  |                  |            |                          |        |                |
| Speed min pos [FF]                               | 5   | U32    | 0      | 2 <sup>32</sup> -1 | 0                | 0                | ✓          | R/Z                      | -      | -              |
| Speed max pos [FF]                               | 3   | U32    | 0      | 2 <sup>32</sup> -1 | 5000             | 5000             | ✓          | R/Z                      | -      | -              |
| Speed min neg [FF]                               | 6   | U32    | 0      | 2 <sup>32</sup> -1 | 0                | 0                | ✓          | R/Z                      | -      | -              |
| Speed max neg [FF]                               | 4   | U32    | 0      | 2 <sup>32</sup> -1 | 5000             | 5000             | ✓          | R/Z                      | -      | -              |
| Speed limited                                    | 372 | U16    | 0      | 1                  |                  |                  | -          | R                        | QD     | R              |
| Speed not limited                                |     |        |        |                    |                  |                  |            | 0                        | L      | 0              |
| Speed limited                                    |     |        |        |                    |                  |                  |            | 1                        | H      | 1              |



| Parameter   | No. | Format | Value |                    |                   |                   | Access via |                          |                  |                         |  |
|---|-----|--------|-------|--------------------|-------------------|-------------------|------------|--------------------------|------------------|-------------------------|--|
|   |     |        | min   | max                | Factory American  | Factory European  | Keyp.      | RS485/<br>BUS/<br>Opt2-M | Term.            | Opt2-A/<br>PDC          |  |
| <b>LIMITS \ Current limits</b>  |     |        |       |                    |                   |                   |            |                          |                  |                         |  |
| T current lim type<br>T lim +/-<br>T lim mot gen                              | 715 | U16    | 0     | 1                  | 0                 | 0                 | ✓          | R/Z<br>0<br>1            | -                | -                       |  |
| T current lim [%]   | 7   | U16    | 0     | 200                | 150               | 150               | ✓          | R/W                      | IA               | R/W                     |  |
| T current lim + [%]   | 8   | U16    | 0     | 200                | 150               | 150               | ✓          | R/W                      | IA               | R/W                     |  |
| T current lim - [%]   | 9   | U16    | 0     | 200                | 150               | 150               | ✓          | R/W                      | IA               | R/W                     |  |
| Curr limit state<br>Curr. limit not reached<br>Curr. limit reached            | 349 | U16    | 0     | 1                  |                   |                   | -          | R<br>0<br>1              | QD<br>L<br>H     | R<br>0<br>1             |  |
| In use Tcur lim+ [%]  | 10  | U16    | 0     | 200                |                   |                   | ✓          | R                        | -                | R                       |  |
| In use Tcur lim- [%]  | 11  | U16    | 0     | 200                |                   |                   | ✓          | R                        | -                | R                       |  |
| Current lim red [%]   | 13  | U16    | 0     | 200                | 100               | 100               | ✓          | R/W                      | -                | R/W                     |  |
| Torque reduct<br><br>Not active<br>Active                                     | 342 | U16    | 0     | 1                  | Not active<br>(0) | Not active<br>(0) | ✓          | R/W<br><br>0<br>1        | ID<br><br>L<br>H | R/W<br><br>0<br>1       |  |
| <b>LIMITS \ Flux limits (Fld curr limits)</b>                                 |     |        |       |                    |                   |                   |            |                          |                  |                         |  |
| Flux current max [%]  | 467 | U16    | P468  | 100                | 100               | 100               | ✓          | R/W                      | -                | R/W                     |  |
| Flux current min [%]  | 468 | U16    | 0     | P467               | 5                 | 5                 | ✓          | R/W                      | -                | ----                    |  |
| <b>RAMP \ Acceleration</b>  |     |        |       |                    |                   |                   |            |                          |                  |                         |  |
| Acc delta speed [FF]  | 21  | U32    | 0     | 2 <sup>32</sup> -1 | 100               | 100               | ✓          | R/W                      | -                | -                       |  |
| Acc delta time [s]  | 22  | U16    | 0     | 65535              | 1                 | 1                 | ✓          | R/W                      | -                | -                       |  |
| <b>RAMP \ Deceleration</b>  |     |        |       |                    |                   |                   |            |                          |                  |                         |  |
| Dec delta speed [FF]  | 29  | U32    | 0     | 2 <sup>32</sup> -1 | 100               | 100               | ✓          | R/W                      | -                | -                       |  |
| Dec delta time [s]  | 30  | U16    | 0     | 65535              | 1                 | 1                 | ✓          | R/W                      | -                | -                       |  |
| <b>RAMP \ Quick stop</b>  |     |        |       |                    |                   |                   |            |                          |                  |                         |  |
| QStp delta speed [FF]   | 37  | U32    | 0     | 2 <sup>32</sup> -1 | 1000              | 1000              | ✓          | R/W                      | -                | -                       |  |
| QStp delta time [s]   | 38  | U16    | 0     | 65535              | 1                 | 1                 | ✓          | R/W                      | -                | -                       |  |
| <b>RAMP</b>   |     |        |       |                    |                   |                   |            |                          |                  |                         |  |
| Ramp shape<br><br>Linear<br>S-Shaped  | 18  | U16    | 0     | 1                  | Linear<br>(0)     | Linear<br>(0)     | ✓          | R/Z<br><br>0<br>1        | -                | -                       |  |
| S shape t const [ms]  | 19  | Float  | 100   | 3000               | 300               | 300               | ✓          | R/W                      | -                | -                       |  |
| S acc t const [ms]  | 663 | Float  | 100   | 3000               | 300               | 300               | ✓          | R/W                      | -                | -                       |  |
| S dec t const [ms]  | 664 | Float  | 100   | 3000               | 300               | 300               | ✓          | R/W                      | -                | -                       |  |
| Ramp +/- delay [ms]   | 20  | U16    | 0     | 65535              | 100               | 100               | ✓          | R/W                      | -                | -                       |  |
| Fwd-Rev<br><br>No direction<br>Fwd direction<br>Rev direction<br>No direction | 673 | U16    | 0     | 3                  | 1                 | 1                 | ✓          | R/W<br>0<br>1<br>2<br>3  | ID               | R/W<br>0<br>1<br>2<br>3 |  |
| Forward sign  | 293 | U16    | 0     | 1                  | 0                 | 0                 | -          | R/W                      | ID               | R/W                     |  |
| Reverse sign  | 294 | U16    | 0     | 1                  | 0                 | 0                 | -          | R/W                      | ID               | R/W                     |  |
| Enable ramp<br><br>Enabled<br>Disabled  | 245 | I16    | 0     | 1                  | Enabled<br>(1)    | Enabled<br>(1)    | ✓          | R/Z<br><br>1<br>0        | -                | -                       |  |
| Ramp out = 0<br><br>Active<br>Not active                                      | 344 | U16    | 0     | 1                  | Not active<br>(1) | Not active<br>(1) | ✓          | R/W<br><br>0<br>1        | ID<br><br>L<br>H | R/W<br><br>0<br>1       |  |
| Ramp in = 0<br><br>Active<br>Not active                                       | 345 | U16    | 0     | 1                  | Not active<br>(1) | Not active<br>(1) | ✓          | R/W<br><br>0<br>1        | ID<br><br>L<br>H | R/W<br><br>0<br>1       |  |
| Freeze ramp<br><br>Active<br>Not active                                       | 373 | U16    | 0     | 1                  | Not active<br>(1) | Not active<br>(1) | ✓          | R/W<br><br>0<br>1        | ID<br><br>H<br>L | R/W<br><br>1<br>0       |  |

| Parameter  | No.  | Format | Value  |                   |                         |                         | Access via |                          |              |                |
|--|------|--------|--------|-------------------|-------------------------|-------------------------|------------|--------------------------|--------------|----------------|
|  |      |        | min    | max               | Factory American        | Factory European        | Key.       | RS485/<br>BUS/<br>Opt2-M | Term.        | Opt2-A/<br>PDC |
| Ramp +<br>Acc.CW + Dec. anti-CW<br>Other states    | 346  | U16    | 0      | 1                 | -                       | -                       | -          | R<br>1<br>0              | QD<br>H<br>L | R<br>1<br>0    |
| Ramp -<br>Acc.anti-CW + Dec. CW<br>Other states    | 347  | U16    | 0      | 1                 | -                       | -                       | -          | R<br>1<br>0              | QD<br>H<br>L | R<br>1<br>0    |
| <b>SPEED REGULAT</b>                               |      |        |        |                   |                         |                         |            |                          |              |                |
| Speed ref [rpm]                                    | 118  | I16    | -32768 | +32767            | -                       | -                       | ✓          | R                        | QA           | R              |
| Speed reg output [% ]                              | 236  | I16    | -200   | +200<br>see 6.7.1 | -                       | -                       | ✓          | R                        | QA           | R              |
| Lock speed reg<br>ON<br>OFF                        | 322  | U16    | 0      | 1                 | OFF                     | OFF                     | ✓          | R/W<br>1<br>0            | ID<br>L<br>H | R/W<br>1<br>0  |
| Enable spd reg<br>Enable<br>Disable                | 242  | I16    | 0      | 1                 | Enabled                 | Enabled                 | ✓          | R/Z<br>1<br>0            | -            | -              |
| Lock speed I<br>Active<br>Not active               | 348  | U16    | 0      | 1                 | Not active<br>(1)       | Not active<br>(1)       | ✓          | R/W<br>0<br>1            | ID<br>L<br>H | R/W<br>0<br>1  |
| Aux spd fun sel<br>Speed up<br>Inertia-loss cp     | 1016 | U16    | 0      | 1                 | Speed up<br>(0)         | Speed up<br>(0)         | ✓          | R/Z<br>0<br>1            | -            | -              |
| Prop filter [ms]                                   | 444  | U16    | 0      | 1000              | 0                       | 0                       | ✓          | R/W                      | -            | -              |
| <b>SPEED REGULAT. \ Self tuning</b>                |      |        |        |                   |                         |                         |            |                          |              |                |
| Fwd-Rev spd tune<br>Fwd direction<br>Rev direction | 1029 | U16    | 1      | 2                 | Fwd<br>Direction<br>(1) | Fwd<br>Direction<br>(1) | ✓          | R/Z<br>1<br>2            | -            | -              |
| Test T curr lim [%]                                | 1048 | U16    | 0      | S                 | 20                      | 20                      | ✓          | R/Z                      | -            | -              |
| Start  | 1027 | U16    | 0      | 65535             | -                       | -                       | ✓          | C                        | -            | -              |
| Inertia [kg*m*m*]                                  | 1014 | Float  | 0.001  | 999.999           | S                       | S                       | ✓          | R/W                      | -            | -              |
| Inertia Nw [kg*m*m*]                               | 1030 | Float  | 0.001  | 999.999           | -                       | -                       | ✓          | R                        | -            | -              |
| Friction [N*m]                                     | 1015 | Float  | 0.000  | 99.999            | S                       | S                       | ✓          | R/W                      | -            | -              |
| Friction Nw [N*m]                                  | 1031 | Float  | 0.00   | 99.99             | -                       | -                       | ✓          | R                        | -            | -              |
| Speed P [%]  | 87   | Float  | 0.00   | 100.00            | S                       | S                       | ✓          | R/W                      | -            | -              |
| Speed P Nw [%]                                     | 1032 | Float  | 0.00   | 100.00            | -                       | -                       | ✓          | R                        | -            | -              |
| Speed I [%]  | 88   | Float  | 0.00   | 100.00            | S                       | S                       | ✓          | R/W                      | -            | -              |
| Speed I Nw [%]                                     | 1033 | Float  | 0.00   | 100.00            | -                       | -                       | ✓          | R                        | -            | -              |
| Take val   | 1028 | U16    | 0      | 65535             | -                       | -                       | ✓          | Z/C                      | -            | -              |
| <b>SPEED REGULAT \ Spd zero logic</b>              |      |        |        |                   |                         |                         |            |                          |              |                |
| Enable spd=0 I<br>Enabled<br>Disabled              | 123  | U16    | 0      | 1                 | Disabled                | Disabled                | ✓          | R/Z<br>1<br>0            | -            | -              |
| Enable spd=0 R<br>Enabled<br>Disabled              | 124  | U16    | 0      | 1                 | Disabled                | Disabled                | ✓          | R/Z<br>1<br>0            | -            | -              |
| Enable spd=0 P<br>Enabled<br>Disabled              | 125  | U16    | 0      | 1                 | Disabled                | Disabled                | ✓          | R/Z<br>1<br>0            | -            | -              |
| Spd=0 P gain [%]                                   | 126  | Float  | 0.00   | 100.00            | 10.00                   | 10.00                   | ✓          | R/W                      | -            | -              |
| Ref 0 level [FF]                                   | 106  | U16    | 1      | 32767             | 10                      | 10                      | ✓          | R/W                      | -            | -              |

| Parameter   | No.  | Format | Value |         |                          |                          | Access via |                          |        |                |
|---|------|--------|-------|---------|--------------------------|--------------------------|------------|--------------------------|--------|----------------|
|   |      |        | min   | max     | Factory American         | Factory European         | Keyp.      | RS485/<br>BUS/<br>Opt2-M | Term.  | Opt2-A/<br>PDC |
| <b>SPEED REGULAT \ Speed up</b>                   |      |        |       |         |                          |                          |            |                          |        |                |
| Speed up gain [%]                                 | 445  | Float  | 0.00  | 100.00  | 0.00                     | 0.00                     | ✓          | R/W                      | -      | -              |
| Speed up base [ms]                                | 446  | Float  | 0     | 16000   | 1000                     | 1000                     | ✓          | R/W                      | -      | -              |
| Speed up filter [ms]                              | 447  | U16    | 0     | 1000    | 0                        | 0                        | ✓          | R/W                      | -      | -              |
| <b>SPEED REGULAT \ Droop function</b>             |      |        |       |         |                          |                          |            |                          |        |                |
| Droop gain [%]                                    | 696  | Float  | 0.00  | 100.00  | 0.00                     | 0.00                     | ✓          | R/W                      | -      | -              |
| Droop filter [ms]                                 | 697  | U16    | 0     | 1000    | 0                        | 0                        | ✓          | R/W                      | -      | -              |
| Load comp [%]                                     | 698  | I16    | -200  | +200    | 0                        | 0                        | ✓          | R/W                      | IA     | R/W            |
| Droop limit [FF]                                  | 700  | U16    | 0     | 2*P45   | 1500                     | 1500                     | ✓          | R/W                      | -      | -              |
| Enable droop                                      | 699  | U16    | 0     | 1       | Disabled<br>(0)          | Disabled<br>(0)          | ✓          | R/W                      | ID     | R/W            |
| Enabled   |      |        |       |         |                          |                          |            | 1                        |        | 1              |
| Disabled  |      |        |       |         |                          |                          |            | 0                        |        | 0              |
| <b>SPEED REGULAT \ Inertia/loss cp</b>            |      |        |       |         |                          |                          |            |                          |        |                |
| Inertia [kg*m*m]                                  | 1014 | Float  | 0.001 | 999.999 | S                        | S                        | ✓          | R/W                      | -      | -              |
| Friction [N*m]                                    | 1015 | Float  | 0.000 | 99.999  | S                        | S                        | ✓          | R/W                      | -      | -              |
| Torque const [N*m/A]                              | 1013 | Float  | 0.01  | 99.99   | S                        | S                        | ✓          | R                        | -      | -              |
| Inertia c filter [ms]                             | 1012 | U16    | 0     | 1000    | 0                        | 0                        | ✓          | R/W                      | -      | -              |
| <b>CURRENT REGULAT</b>                            |      |        |       |         |                          |                          |            |                          |        |                |
| T current ref [%]                                 | 41   | I16    | -200  | +200    | -                        | -                        | ✓          | R                        | QA     | R              |
| Motor current [%]                                 | 199  | I16    | -250  | 250     | -                        | -                        | ✓          | R                        | QA     | R              |
| Mot cur threshld [%]                              | 1430 | U16    | 0     | 200     | 100                      | 100                      | ✓          | R/W                      | -      | -              |
| Mot cur th delay [ms]                             | 1431 | U16    | 0     | 65535   | 1000                     | 1000                     | ✓          | R/W                      | -      | -              |
| dl/dt delta time                                  | 1520 | U16    | 0     | 100     | 0                        | 0                        | ✓          | R/W                      | -      | -              |
| Arm resistance [ ]                                | 453  | Float  | S     | S       | 0.500                    | 0.500                    | ✓          | R/W                      | -      | -              |
| Arm inductance [mH]                               | 454  | Float  | S     | S       | 4.00                     | 4.00                     | ✓          | R/W                      | -      | -              |
| E int [V]   | 587  | I16    | -80   | +80     | -                        | -                        | ✓          | R                        | QA     | -              |
| R&L Search  | 452  | U16    | 0     | 1       | OFF                      | OFF                      | ✓          | R/Z                      | -      | -              |
| OFF   |      |        |       |         |                          |                          |            | 0                        |        |                |
| ON  |      |        |       |         |                          |                          |            | 1                        |        |                |
| Zero torque                                       | 353  | U16    | 0     | 1       | Not active<br>(1)        | Not active<br>(1)        | ✓          | R/W                      | ID     | R/W            |
| Active  |      |        |       |         |                          |                          |            | 0                        | L      |                |
| Not active  |      |        |       |         |                          |                          |            | 1                        | H      |                |
| <b>FLUX REGULATION (FIELD CURRENT REGULATION)</b> |      |        |       |         |                          |                          |            |                          |        |                |
| Enable flux reg                                   | 497  | U16    | 0     | 1       | Enabled                  | Enabled                  | ✓          | R/W                      | ID     | -              |
| ON (Enabled)                                      |      |        |       |         |                          |                          |            | 1                        | H      |                |
| OFF (Disabled)                                    |      |        |       |         |                          |                          |            | 0                        | L      |                |
| Flux reg mode                                     | 469  | U16    | 0     | 2       | Const.<br>current<br>(0) | Const.<br>current<br>(0) | ✓          | R/Z                      | -      | -              |
| Constant current                                  |      |        |       |         |                          |                          |            | 0                        |        |                |
| Voltage control                                   |      |        |       |         |                          |                          |            | 1                        |        |                |
| External control (OFF)                            |      |        |       |         |                          |                          |            | 2                        |        |                |
| Enable flux weak                                  | 498  | U16    | 0     | 1       | 1                        | 1                        | ✓          | R/W                      | ID     | -              |
| ON (Enabled)                                      |      |        |       |         |                          |                          |            | 1                        | H      |                |
| OFF (Disabled)                                    |      |        |       |         |                          |                          |            | 0                        | L      |                |
| Speed-0 f weak                                    | 499  | U16    | 0     | 1       | 0                        | 0                        | ✓          | R/W                      | -      | -              |
| ON (Enabled)                                      |      |        |       |         |                          |                          |            | 1                        |        |                |
| OFF (Disabled)                                    |      |        |       |         |                          |                          |            | 0                        |        |                |
| Flux reference [%]                                | 500  | Float* | 0.0   | 100.0   | 0.0                      | 0.0                      | ✓          | R                        | QA     | -              |
| Flux current [%]                                  | 234  | Float* | 0.0   | 100.0   | -                        | -                        | ✓          | R                        | QA     | R              |
| Out vlt level                                     | 921  | Float* | 0.00  | 100.0   | 100.0                    | 100.0                    | ✓          | R/W                      | IA, QA | R/W            |

| Parameter  | No.  | Format | Value  |        |                           |                           | Access via |                          |       |                |
|--|------|--------|--------|--------|---------------------------|---------------------------|------------|--------------------------|-------|----------------|
|  |      |        | min    | max    | Factory American          | Factory European          | Key.       | RS485/<br>BUS/<br>Opt2-M | Term. | Opt2-A/<br>PDC |
| <b>FLUX REGULATION (FIELD CURRENT REGULATION) \ Flux \ if curve</b>        |      |        |        |        |                           |                           |            |                          |       |                |
| I field cnst 40  | 916  | Float  | 0.0    | 100.0  | 40.0                      | 40.0                      | ✓          | R/Z                      |       | -              |
| I field cnst 70  | 917  | Float  | 0.0    | 100.0  | 70.0                      | 70.0                      | ✓          | R/Z                      |       | -              |
| I field cnst 90  | 918  | Float  | 0.0    | 100.0  | 90.0                      | 90.0                      | ✓          | R/Z                      |       | -              |
| Set flux / if  | 919  | U16    | 0      | 1      | 0                         | 0                         | ✓          | Z/C                      |       | -              |
| Reset flux / if  | 920  | U16    | 0      | 1      | 0                         | 0                         | ✓          | Z/C                      |       | -              |
| Nom flux curr [A]  | 374  | Float  | 0.5    | 70.0   | S                         | S                         | ✓          | R/Z                      | -     | -              |
| Motor nom flux   | 280  | Float  | 0.00   | P374   | P374                      | P374                      | ✓          | R/Z                      | -     | -              |
| <b>REG PARAMETERS \ Percent values \ Speed regulator</b>                   |      |        |        |        |                           |                           |            |                          |       |                |
| Speed P [%]  | 87   | Float  | 0.00   | 100.00 | 10.00                     | 10.00                     | ✓          | R/W                      | -     | -              |
| Speed I [%]  | 88   | Float  | 0.00   | 100.00 | 1.00                      | 1.00                      | ✓          | R/W                      | -     | -              |
| Speed P bypass [%]   | 459  | Float  | 0.00   | 100.00 | 10.00                     | 10.00                     | ✓          | R/W                      | -     | -              |
| Speed I bypass [%]   | 460  | Float  | 0.00   | 100.00 | 1.00                      | 1.00                      | ✓          | R/W                      | -     | -              |
| <b>REG PARAMETERS \ Percent values \ Flux regulator ( Field regulator)</b> |      |        |        |        |                           |                           |            |                          |       |                |
| Flux P [%]   | 91   | Float  | 0.00   | 100.00 | 2.00                      | 2.00                      | ✓          | R/W                      | -     | -              |
| Flux I [%]   | 92   | Float  | 0.00   | 100.00 | 1.00                      | 1.00                      | ✓          | R/W                      | -     | -              |
| <b>REG PARAMETERS \ Percent values \ Voltage reg</b>                       |      |        |        |        |                           |                           |            |                          |       |                |
| Voltage P [%]  | 493  | Float  | 0.00   | 100.00 | 30.00                     | 30.00                     | ✓          | R/W                      | -     | -              |
| Voltage I [%]  | 494  | Float  | 0.00   | 100.00 | 40.00                     | 40.00                     | ✓          | R/W                      | -     | -              |
| <b>REG PARAMETERS \ Base values \ Speed regulator</b>                      |      |        |        |        |                           |                           |            |                          |       |                |
| Speed P base [A/rpm]   | 93   | Float  | 000.1  | S      | 0.3 x<br>P93max<br>P93max | 0.3 x<br>P93max<br>P93max | ✓          | R/Z                      | -     | -              |
| Speed I base [A/rpm.ms]  | 94   | Float  | 0.001  | S      | 0.3<br>P94max             | 0.3<br>P94max             | ✓          | R/Z                      | -     | -              |
| <b>REG PARAMETERS \ Base values \ Flux regulator (Field regulator)</b>     |      |        |        |        |                           |                           |            |                          |       |                |
| Flux P base  | 97   | Float  | 1      | 32767  | 3277                      | 3277                      | ✓          | R/Z                      | -     | -              |
| Flux I base  | 98   | Float  | 1      | 32767  | 3277                      | 3277                      | ✓          | R/Z                      | -     | -              |
| <b>REG PARAMETERS \ Base values \ Voltage reg</b>                          |      |        |        |        |                           |                           |            |                          |       |                |
| Voltage P base [f%/V]  | 495  | Float  | 0.0100 | S      | S                         | S                         | ✓          | R/Z                      | -     | -              |
| Voltage I base [f%/V.ms]   | 496  | Float  | 0.01   | S      | S                         | S                         | ✓          | R/Z                      | -     | -              |
| <b>REG PARAMETERS \ In use values</b>                                      |      |        |        |        |                           |                           |            |                          |       |                |
| Speed P in use [%]   | 99   | Float  | 0.00   | 100.00 | S                         | S                         | ✓          | R                        | -     | -              |
| Speed I in use [%]   | 100  | Float  | 0.00   | 100.00 | S                         | S                         | ✓          | R                        | -     | -              |
| <b>CONFIGURATION</b>   |      |        |        |        |                           |                           |            |                          |       |                |
| Main commands<br>Terminals<br>Digital                                      | 252  | U16    | 0      | 1      | Term.(0)                  | Term.(0)                  | ✓          | R/Z<br>0<br>1            | -     | -              |
| Control mode<br>Local<br>Bus   | 253  | U16    | 0      | 1      | Local (0)                 | Local (0)                 | ✓          | R/Z<br>0<br>1            | -     | -              |
| Speed base value [FF]  | 45   | U32*** | 1      | 16383  | 1500                      | 1500                      | ✓          | R/Z                      | -     | R              |
| Full load curr [A]   | 179  | Float  | 0.1    | P465   | P465                      | P465                      | ✓          | R/Z                      | -     | -              |
| Max out voltage [V]  | 175  | Float  | 20     | 999    | 400                       | 400                       | ✓          | R/Z                      | -     | -              |
| Ok relay funct<br>Drive healthy<br>Ready to Start                          | 412  | I16    | 0      | 1      | 0                         | 0                         | ✓          | R/Z<br>0<br>1            | -     | -              |
| En Tcurr HiRes   | 1521 | I16    | 0      | 1      | 0                         | 0                         | ✓          | R/Z                      | -     | -              |

| Parameter                                      | No. | Format  | Value  |                     |                  |                  | Access via |                          |       |                |
|--|-----|---------|--------|---------------------|------------------|------------------|------------|--------------------------|-------|----------------|
|  |     |         | min    | max                 | Factory American | Factory European | Keyp.      | RS485/<br>BUS/<br>Opt2-M | Term. | Opt2-A/<br>PDC |
| <b>CONFIGURATION \ Speed fbk</b>               |     |         |        |                     |                  |                  |            |                          |       |                |
| Motor max speed [rpm]                          | 162 | Float * | 0      | 6553                | 1500             | 1500             | ✓          | R/Z                      | -     | R              |
| Speed fbk sel                                  | 414 | U16     | 0      | 3                   | 1                | 1                | ✓          | R/Z                      | -     | R              |
| Encoder 1<br>Encoder 2<br>Tacho<br>Armature    |     |         |        |                     |                  |                  |            | 0<br>1<br>2<br>3         |       |                |
| Encoder 1 state<br>Encoder Fault<br>Encoder ok | 648 | U16     | 0      | 1                   |                  |                  | -          | R<br>0<br>1              | QD    | R<br>0<br>1    |
| Enable fbk contr                               | 457 | U16     | 0      | 1                   | Enabled<br>(1)   | Enabled<br>(1)   | ✓          | R/Z                      | -     | -              |
| Enabled<br>Disabled                            |     |         |        |                     |                  |                  |            | 1<br>0                   |       |                |
| Enable fbk bypas                               | 458 | U16     | 0      | 1                   | 0                | 0                | ✓          | R/Z                      | -     | -              |
| Enabled<br>Disabled                            |     |         |        |                     |                  |                  |            | 1<br>0                   |       |                |
| Flux weak speed [%]                            | 456 | U16     | 0      | 100                 | 100              | 100              | ✓          | R/Z                      | -     | R              |
| Speed fbk error [%]                            | 455 | U16     | 0      | 100                 | 22               | 22               | ✓          | R/Z                      | -     | -              |
| Tacho scale                                    | 562 | Float   | 0.90   | 3.00                | 1.00             | 1.00             | ✓          | R/W                      | -     | -              |
| Speed offset                                   | 563 | Float   | -20.00 | +20.00              | 0.00             | 0.00             | ✓          | R/W                      | -     | -              |
| Encoder 1 pulses                               | 416 | Float * | 600    | 9999                | 1024             | 1024             | ✓          | R/Z                      | -     | R              |
| Encoder 2 pulses                               | 169 | Float * | 150    | 9999                | 1000             | 1000             | ✓          | R/Z                      | -     | R              |
| Refresh enc 1                                  | 649 | U16     | 0      | 1                   | Disabled<br>(0)  | Disabled<br>(0)  | ✓          | R/W                      | -     | -              |
| Enabled<br>Disabled                            |     |         |        |                     |                  |                  |            | 1<br>0                   |       |                |
| Encoder 2 state<br>Encoder Fault<br>Encoder ok | 651 | U16     | 0      | 1                   |                  |                  | -          | R<br>0<br>1              | QD    | R<br>0<br>1    |
| Refresh enc 2                                  | 652 | U16     | 0      | 1                   | Disabled<br>(0)  | Disabled<br>(0)  | ✓          | R/W                      | -     | -              |
| Enabled<br>Disabled                            |     |         |        |                     |                  |                  |            | 1<br>0                   |       |                |
| Enable ind store                               | 911 | U16     | 0      | 1                   | Disabled<br>(0)  | Disabled<br>(0)  | ✓          | R/W                      | -     | R/W            |
| Enabled<br>Disabled                            |     |         |        |                     |                  |                  |            | 1<br>0                   |       |                |
| Ind store ctrl                                 | 912 | U16     | 0      | 65535               | 0                | 0                | -          | R/W                      | -     | R/W            |
| Index storing                                  | 913 | U32     | 0      | +2 <sup>32</sup> -1 | 0                | 0                | -          | R                        | -     | R              |
| <b>CONFIGURATION \ Drive type</b>              |     |         |        |                     |                  |                  |            |                          |       |                |
| Drive size [A]                                 | 465 | U16     | 0      | S                   | S                | S                | ✓          | R                        | -     | R              |
| 2B + E   | 201 | U16     | 0      | 1                   | 0                | 0                | ✓          | R/Z                      | -     | -              |
| ON<br>OFF                                      |     |         |        |                     |                  |                  |            | 0<br>1                   |       |                |
| Size selection                                 | 464 | U16     | 0      | 1                   | 1                | 1                | ✓          | R/Z                      | -     | -              |
| Standard<br>American                           |     |         |        |                     |                  |                  |            | 0<br>1                   |       |                |
| Software version                               | 331 | Text    |        |                     |                  |                  | ✓          | R                        | -     | -              |
| Drive type                                     | 300 | U16     | 10     | 11                  | S                | S                | -          | R                        | -     | R              |
| TPD32-...-2B<br>TPD32-...-4B                   |     |         |        |                     |                  |                  |            | 10<br>11                 |       | 10<br>11       |
| <b>CONFIGURATION \ Dimension fact</b>          |     |         |        |                     |                  |                  |            |                          |       |                |
| Dim factor num                                 | 50  | I32***  | 1      | 65535               | 1                | 1                | ✓          | R/Z                      | -     | R              |
| Dim factor den                                 | 51  | I32***  | 1      | +2 <sup>31</sup> -1 | 1                | 1                | ü          | R/Z                      | -     | R              |
| Dim factor text                                | 52  | Text    |        |                     | rpm              | rpm              | ✓          | R/Z                      | -     | -              |
| <b>CONFIGURATION \ Face value fact</b>         |     |         |        |                     |                  |                  |            |                          |       |                |
| Face value num                                 | 54  | I16     | 1      | +32767              | 1                | 1                | ✓          | R/Z                      | -     | R              |
| Face value den                                 | 53  | I16     | 1      | +32767              | 1                | 1                | ✓          | R/Z                      | -     | R              |

| Parameter   | No.  | Format | Value |       |                  |                  | Access via |                                   |       |                |
|---|------|--------|-------|-------|------------------|------------------|------------|-----------------------------------|-------|----------------|
|   |      |        | min   | max   | Factory American | Factory European | Key.       | RS485/<br>BUS/<br>Opt2-M          | Term. | Opt2-A/<br>PDC |
| <b>CONFIGURATION \ Prog alarms \ Failure supply</b> |      |        |       |       |                  |                  |            |                                   |       |                |
| Latch   | 194  | U16    | 0     | 1     | ON               | ON               | ✓          | R/Z<br>1<br>0                     | -     | -              |
| Ok relay open                                       | 195  | I16    | 0     | 1     | ON               | ON               | ✓          | R/W<br>1<br>0                     | -     | -              |
| <b>CONFIGURATION \ Prog alarms \ Undervoltage</b>   |      |        |       |       |                  |                  |            |                                   |       |                |
| Undervolt thr [V]                                   | 481  | U16    | 0     | 1000  | 230              | 230              | ✓          | R/W                               | -     | -              |
| Latch   | 357  | U16    | 0     | 1     | ON               | ON               | ✓          | R/Z<br>1<br>0                     | -     | -              |
| Ok relay open                                       | 358  | I16    | 0     | 1     | ON               | ON               | ✓          | R/W<br>1<br>0                     | -     | -              |
| Hold off time [ms]                                  | 470  | U16    | 0     | 100   | 0                | 0                | ✓          | R/W                               | -     | -              |
| Restart time [ms]                                   | 359  | U16    | 0     | 65535 | 1000             | 1000             | ✓          | R/W                               | -     | -              |
| <b>CONFIGURATION \ Prog alarms \ Overvoltage</b>    |      |        |       |       |                  |                  |            |                                   |       |                |
| Activity  | 203  | U16    | 0     | 2     | Ignore           | Ignore           | ✓          | R/Z<br>0<br>1<br>2                | -     | -              |
| Latch   | 361  | U16    | 0     | 1     | ON               | ON               | ✓          | R/Z<br>1<br>0                     | -     | -              |
| Ok relay open                                       | 362  | I16    | 0     | 1     | ON               | ON               | ✓          | R/W<br>1<br>0                     | -     | -              |
| Hold off time [ms]                                  | 482  | U16    | 0     | 10000 | 0                | 0                | ✓          | R/W                               | -     | -              |
| Restart time [ms]                                   | 483  | U16    | 0     | 10000 | 0                | 0                | ✓          | R/W                               | -     | -              |
| <b>CONFIGURATION \ Prog alarms \ Overspeed</b>      |      |        |       |       |                  |                  |            |                                   |       |                |
| Overspeed thr [rpm]                                 | 1426 | Float  | 0     | 5000  | 4000             | 4000             | ✓          | R/Z                               | -     | -              |
| Activity  | 1422 | U16    | 0     | 2     | Ignore           | Ignore           | ✓          | R/Z<br>0<br>1<br>2<br>3<br>4<br>5 | -     | -              |
| Latch   | 1421 | U16    | 0     | 1     | ON               | ON               | ✓          | R/Z<br>1<br>0                     | -     | -              |
| Ok relay open                                       | 1423 | I16    | 0     | 1     | ON               | ON               | ✓          | R/W<br>1<br>0                     | -     | -              |
| Hold off time [ms]                                  | 1424 | U16    | 0     | 10000 | 0                | 0                | ✓          | R/W                               | -     | -              |
| Restart time [ms]                                   | 1425 | U16    | 0     | 10000 | 0                | 0                | ✓          | R/W                               | -     | -              |
| <b>CONFIGURATION \ Prog alarms \ Heatsink</b>       |      |        |       |       |                  |                  |            |                                   |       |                |
| Activity  | 368  | U16    | 1     | 5     | Disable drive    | Disable drive    | ✓          | R/Z<br>1<br>2<br>3<br>4<br>5      | -     | -              |
| Ok relay open                                       | 370  | I16    | 0     | 1     | ON               | ON               | ✓          | R/W<br>1<br>0                     | -     | -              |

| Parameter   | No.  | Format | Value |       |                  |                  | Access via |                          |       |                |
|---|------|--------|-------|-------|------------------|------------------|------------|--------------------------|-------|----------------|
|   |      |        | min   | max   | Factory American | Factory European | Keyp.      | RS485/<br>BUS/<br>Opt2-M | Term. | Opt2-A/<br>PDC |
| <b>CONFIGURATION \ Prog alarms \ Overtemp motor</b> |      |        |       |       |                  |                  |            |                          |       |                |
| Activity  | 365  | U16    |       |       | Disable drive    | Disable drive    | ✓          | R/Z                      | -     | -              |
| Ignore  |      |        |       |       |                  |                  |            | 0                        |       |                |
| Warning   |      |        |       |       |                  |                  |            | 1                        |       |                |
| Disable drive                                       |      |        |       |       |                  |                  |            | 2                        |       |                |
| Quick stop  |      |        |       |       |                  |                  |            | 3                        |       |                |
| Normal stop   |      |        |       |       |                  |                  |            | 4                        |       |                |
| Curr lim stop                                       |      |        |       |       |                  |                  |            | 5                        |       |                |
| Ok relay open                                       | 367  | I16    |       |       | ON               | ON               | ✓          | R/W                      | -     | -              |
| ON  |      |        |       |       |                  |                  |            | 1                        |       |                |
| OFF   |      |        |       |       |                  |                  |            | 0                        |       |                |
| <b>CONFIGURATION \ Prog alarms \ External fault</b> |      |        |       |       |                  |                  |            |                          |       |                |
| Activity  | 354  | U16    | 1     | 5     | Disable drive    | Disable drive    | ✓          | R/Z                      | -     | -              |
| Warning   |      |        |       |       |                  |                  |            | 1                        |       |                |
| Disable drive                                       |      |        |       |       |                  |                  |            | 2                        |       |                |
| Quick stop  |      |        |       |       |                  |                  |            | 3                        |       |                |
| Normal stop   |      |        |       |       |                  |                  |            | 4                        |       |                |
| Curr lim stop                                       |      |        |       |       |                  |                  |            | 5                        |       |                |
| Latch   | 355  | U16    | 0     | 1     | ON               | ON               | ✓          | R/Z                      | -     | -              |
| ON  |      |        |       |       |                  |                  |            | 1                        |       |                |
| OFF   |      |        |       |       |                  |                  |            | 0                        |       |                |
| Ok relay open                                       | 356  | I16    | 0     | 1     | ON               | ON               | ✓          | R/W                      | -     | -              |
| ON  |      |        |       |       |                  |                  |            | 1                        |       |                |
| OFF   |      |        |       |       |                  |                  |            | 0                        |       |                |
| Hold off time [ms]                                  | 502  | U16    | 0     | 10000 | 0                | 0                | ✓          | R/W                      | -     | -              |
| Restart time [ms]                                   | 501  | U16    | 0     | 10000 | 0                | 0                | ✓          | R/W                      | -     | -              |
| <b>CONFIGURATION \ Prog alarms \ Brake fault</b>    |      |        |       |       |                  |                  |            |                          |       |                |
| Activity  | 1296 | U16    | 0     | 5     | Disable drive    | Disable drive    | ✓          | R/Z                      | -     | -              |
| Ignore  |      |        |       |       |                  |                  |            | 0                        |       |                |
| Warning   |      |        |       |       |                  |                  |            | 1                        |       |                |
| Disable drive                                       |      |        |       |       |                  |                  |            | 2                        |       |                |
| Quick stop  |      |        |       |       |                  |                  |            | 3                        |       |                |
| Normal stop   |      |        |       |       |                  |                  |            | 4                        |       |                |
| Curr lim stop                                       |      |        |       |       |                  |                  |            | 5                        |       |                |
| Ok relay open                                       | 1297 | I16    | 0     | 1     | ON               | ON               | ✓          | R/W                      | -     | -              |
| ON  |      |        |       |       |                  |                  |            | 0                        |       |                |
| OFF   |      |        |       |       |                  |                  |            | 1                        |       |                |
| <b>CONFIGURATION \ Prog alarms \ Motor I2t ovrl</b> |      |        |       |       |                  |                  |            |                          |       |                |
| Activity  | 1419 | U16    | 0     | 2     | Disable drive    | Disable drive    | ✓          | R/Z                      | -     | -              |
| Ignore  |      |        |       |       |                  |                  |            | 0                        |       |                |
| Warning   |      |        |       |       |                  |                  |            | 1                        |       |                |
| Disable drive                                       |      |        |       |       |                  |                  |            | 2                        |       |                |
| Latch   | 1442 | U16    | 0     | 1     | ON               | ON               | ✓          | R/Z                      | -     | -              |
| ON  |      |        |       |       |                  |                  |            | 0                        |       |                |
| OFF   |      |        |       |       |                  |                  |            | 1                        |       |                |
| Ok relay open                                       | 1420 | I16    | 0     | 1     | ON               | ON               | ✓          | R/W                      | -     | -              |
| ON  |      |        |       |       |                  |                  |            | 0                        |       |                |
| OFF   |      |        |       |       |                  |                  |            | 1                        |       |                |
| <b>CONFIGURATION \ Prog alarms \ Drive I2t ovrl</b> |      |        |       |       |                  |                  |            |                          |       |                |
| Ok relay open                                       | 1441 | I16    | 0     | 1     | ON               | ON               | ✓          | R/W                      | -     | -              |
| ON  |      |        |       |       |                  |                  |            | 0                        |       |                |
| OFF   |      |        |       |       |                  |                  |            | 1                        |       |                |

| Parameter   | No.  | Format | Value |       |                  |                  | Access via |                          |       |                |  |
|---|------|--------|-------|-------|------------------|------------------|------------|--------------------------|-------|----------------|--|
|   |      |        | min   | max   | Factory American | Factory European | Keyp.      | RS485/<br>BUS/<br>Opt2-M | Term. | Opt2-A/<br>PDC |  |
| <b>CONFIGURATION \ Prog alarms \ Overcurrent</b>                        |      |        |       |       |                  |                  |            |                          |       |                |  |
| Overcurrent thr [%]   | 584  | U16    | 0     | 200   | 160              | 160              | ✓          | R/W                      | -     | -              |  |
| Activity<br>Ignore<br>Warning<br>Disable drive                          | 212  | U16    | 0     | 2     | Ignore           | Ignore           | ✓          | R/Z<br>0<br>1<br>2       | -     | -              |  |
| Latch<br>ON<br>OFF  | 363  | U16    | 0     | 1     | ON               | ON               | ✓          | R/Z<br>1<br>0            | -     | -              |  |
| Ok relay open<br>ON<br>OFF  | 364  | I16    | 0     | 1     | ON               | ON               | ✓          | R/W<br>1<br>0            | -     | -              |  |
| Hold off time [ms]  | 586  | U16    | 0     | 10000 | 0                | 0                | ✓          | R/W                      | -     | -              |  |
| Restart time [ms]   | 585  | U16    | 0     | 10000 | 0                | 0                | ✓          | R/W                      | -     | -              |  |
| <b>CONFIGURATION \ Prog alarms \ Field loss</b>                         |      |        |       |       |                  |                  |            |                          |       |                |  |
| Activity<br>Ignore<br>Warning<br>Disable drive                          | 473  | U16    | 0     | 2     | Disable drive    | Disable drive    | ✓          | R/Z<br>0<br>1<br>2       | -     | -              |  |
| Latch<br>ON<br>OFF  | 471  | U16    | 0     | 1     | ON               | ON               | ✓          | R/Z<br>1<br>0            | -     | -              |  |
| Ok relay open<br>ON<br>OFF  | 472  | I16    | 0     | 1     | ON               | ON               | ✓          | R/W<br>1<br>0            | -     | -              |  |
| Hold off time [ms]  | 475  | U16    | 0     | 10000 | 0                | 0                | ✓          | R/W                      | -     | -              |  |
| Restart time [ms]   | 474  | U16    | 0     | 10000 | 0                | 0                | ✓          | R/W                      | -     | -              |  |
| <b>CONFIGURATION \ Prog alarms \ Delta frequency</b>                    |      |        |       |       |                  |                  |            |                          |       |                |  |
| Delta freq thres [%]  | 1437 | Float  | 1     | 15    | 5                | 5                | ✓          | R/Z                      | -     | -              |  |
| Activity<br>Ignore<br>Warning<br>Disable drive                          | 1432 | U16    | 0     | 2     | Ignore           | Ignore           | ✓          | R/Z<br>0<br>1<br>2       | -     | -              |  |
| Latch<br>ON<br>OFF  | 1433 | U16    | 0     | 1     | ON               | ON               | ✓          | R/Z<br>0<br>1            | -     | -              |  |
| Ok relay open<br>ON<br>OFF  | 1434 | I16    | 0     | 1     | ON               | ON               | ✓          | R/W<br>0<br>1            | -     | -              |  |
| Hold off time [ms]  | 1435 | U16    | 0     | 10000 | 0                | 0                | ✓          | R/W                      | -     | -              |  |
| Restart time [ms]   | 1436 | U16    | 0     | 10000 | 0                | 0                | ✓          | R/W                      | -     | -              |  |
| <b>CONFIGURATION \ Prog alarms \ Speed fbk loss</b>                     |      |        |       |       |                  |                  |            |                          |       |                |  |
| Activity<br>Warning<br>Disable drive                                    | 478  | U16    | 1     | 2     | Disable drive    | Disable drive    | ✓          | R/Z<br>1<br>2            | -     | -              |  |
| Ok relay open<br>ON<br>OFF  | 477  | I16    | 0     | 1     | ON               | ON               | ✓          | R/W<br>1<br>0            | -     | -              |  |
| Hold off time [ms]  | 480  | U16    | 0     | 10000 | 8                | 8                | ✓          | R/W                      | -     | -              |  |
| <b>CONFIGURATION \ Prog alarms \ Opt2 failure</b>                       |      |        |       |       |                  |                  |            |                          |       |                |  |
| Activity<br>Disable drive<br>Quick stop<br>Normal stop<br>Curr lim stop | 639  | U16    | 0     | 5     | Disable drive    | Disable drive    | ✓          | R/Z<br>2<br>3<br>4<br>5  | -     | -              |  |
| Ok relay open<br>ON<br>OFF  | 640  | I16    | 0     | 1     | ON               | ON               | ✓          | R/W<br>1<br>0            | -     | -              |  |



| Parameter  | No. | Format | Value |       |                  |                  | Access via |                          |       |                |  |
|--|-----|--------|-------|-------|------------------|------------------|------------|--------------------------|-------|----------------|--|
|  |     |        | min   | max   | Factory American | Factory European | Keyp.      | RS485/<br>BUS/<br>Opt2-M | Term. | Opt2-A/<br>PDC |  |
| <b>CONFIGURATION \ Prog alarms \ Bus loss</b>        |     |        |       |       |                  |                  |            |                          |       |                |  |
| Activity   | 634 | U16    | 0     | 5     | Disable drive    | Disable drive    | ✓          | R/Z                      | -     | -              |  |
| Ignore   |     |        |       |       |                  |                  |            | 0                        |       |                |  |
| Warning  |     |        |       |       |                  |                  |            | 1                        |       |                |  |
| Disable drive  |     |        |       |       |                  |                  |            | 2                        |       |                |  |
| Quick stop   |     |        |       |       |                  |                  |            | 3                        |       |                |  |
| Normal stop  |     |        |       |       |                  |                  |            | 4                        |       |                |  |
| Curr lim stop  |     |        |       |       |                  |                  |            | 5                        |       |                |  |
| Latch  | 633 | U16    | 0     | 1     | ON               | ON               | ✓          | R/Z                      | -     | -              |  |
| ON   |     |        |       |       |                  |                  |            | 1                        |       |                |  |
| OFF  |     |        |       |       |                  |                  |            | 0                        |       |                |  |
| Ok relay open  | 635 | I16    | 0     | 1     | ON               | ON               | ✓          | R/W                      | -     | -              |  |
| ON   |     |        |       |       |                  |                  |            | 1                        |       |                |  |
| OFF  |     |        |       |       |                  |                  |            | 0                        |       |                |  |
| Hold off time [ms]                                   | 636 | U16    | 0     | 10000 | 0                | 0                | ✓          | R/W                      | -     | -              |  |
| Restart time [ms]                                    | 637 | U16    | 0     | 10000 | 0                | 0                | ✓          | R/W                      | -     | -              |  |
| <b>CONFIGURATION \ Prog alarms \ Hw opt1 failure</b> |     |        |       |       |                  |                  |            |                          |       |                |  |
| Activity   | 386 | U16    | 1     | 5     | Disable drive    | Disable drive    | ✓          | R/Z                      | -     | -              |  |
| Warning  |     |        |       |       |                  |                  |            | 1                        |       |                |  |
| Disable drive  |     |        |       |       |                  |                  |            | 2                        |       |                |  |
| Quick stop   |     |        |       |       |                  |                  |            | 3                        |       |                |  |
| Normal stop  |     |        |       |       |                  |                  |            | 4                        |       |                |  |
| Curr lim stop  |     |        |       |       |                  |                  |            | 5                        |       |                |  |
| Ok relay open  | 387 | I16    | 0     | 1     | ON               | ON               | ✓          | R/W                      | -     | -              |  |
| ON   |     |        |       |       |                  |                  |            | 1                        |       |                |  |
| OFF  |     |        |       |       |                  |                  |            | 0                        |       |                |  |
| <b>CONFIGURATION \ Prog alarms \ Enable seq err</b>  |     |        |       |       |                  |                  |            |                          |       |                |  |
| Activity   | 728 | U16    | 0     | 2     | Disable drive    | Disable drive    | ✓          | R/Z                      | -     | -              |  |
| Ignore   |     |        |       |       |                  |                  |            | 0                        |       |                |  |
| Disable drive  |     |        |       |       |                  |                  |            | 2                        |       |                |  |
| Latch  | 729 | U16    | 0     | 1     | ON               | ON               | ✓          | R/Z                      | -     | -              |  |
| ON   |     |        |       |       |                  |                  |            | 1                        |       |                |  |
| OFF  |     |        |       |       |                  |                  |            | 0                        |       |                |  |
| Ok relay open  | 730 | U16    | 0     | 1     | ON               | ON               | ✓          | R/W                      | -     | -              |  |
| ON   |     |        |       |       |                  |                  |            | 1                        |       |                |  |
| OFF  |     |        |       |       |                  |                  |            | 0                        |       |                |  |
| <b>CONFIGURATION \ Set serial comm</b>               |     |        |       |       |                  |                  |            |                          |       |                |  |
| Device address                                       | 319 | U16    | 0     | 127   | 0                | 0                | ✓          | R/Z                      | -     | -              |  |
| Ser answer delay                                     | 408 | U16    | 0     | 900   | 0                | 0                | ✓          | R/W                      | --    | ---            |  |
| Ser protocol sel                                     | 323 | U16    | 0     | 2     | SLINK3 (0)       | SLINK3 (0)       | ✓          | R/W                      | --    | ---            |  |
| SLINK3   |     |        |       |       |                  |                  |            | 0                        |       |                |  |
| MODBUS RTU   |     |        |       |       |                  |                  |            | 1                        |       |                |  |
| JBUS   |     |        |       |       |                  |                  |            | 2                        |       |                |  |
| Ser baudrate sel                                     | 326 | U16    | 0     | 4     | 9600 (1)         | 9600 (1)         | ✓          | R/W                      | --    | ---            |  |
| 19200  |     |        |       |       |                  |                  |            | 0                        |       |                |  |
| 9600   |     |        |       |       |                  |                  |            | 1                        |       |                |  |
| 4800   |     |        |       |       |                  |                  |            | 2                        |       |                |  |
| 2400   |     |        |       |       |                  |                  |            | 3                        |       |                |  |
| 1200   |     |        |       |       |                  |                  |            | 4                        |       |                |  |
| <b>CONFIGURATION</b>                                 |     |        |       |       |                  |                  |            |                          |       |                |  |
| Pword 1  | 85  | I32    | 0     | 99999 | 0                | 0                | ✓          | W                        | -     | -              |  |

| Parameter  | No. | Format | Value   |         |                     |                     | Access via |                          |       |                |
|--|-----|--------|---------|---------|---------------------|---------------------|------------|--------------------------|-------|----------------|
|  |     |        | min     | max     | Factory American    | Factory European    | Keyp.      | RS485/<br>BUS/<br>Opt2-M | Term. | Opt2-A/<br>PDC |
| <b>I/O CONFIG \ Analog outputs \ Analog output 1</b> |     |        |         |         |                     |                     |            |                          |       |                |
| Select output 1                                      | 66  | U16    | 0       | 94      | Actual speed (8)    | Actual speed (8)    | ✓          | R/Z                      | -     | -              |
| OFF  |     |        |         |         |                     |                     |            | 0                        |       |                |
| Speed ref 1  |     |        |         |         |                     |                     |            | 1                        |       |                |
| Speed ref 2  |     |        |         |         |                     |                     |            | 2                        |       |                |
| Ramp ref 1   |     |        |         |         |                     |                     |            | 3                        |       |                |
| Ramp ref 2   |     |        |         |         |                     |                     |            | 4                        |       |                |
| Ramp ref   |     |        |         |         |                     |                     |            | 5                        |       |                |
| Speed ref  |     |        |         |         |                     |                     |            | 6                        |       |                |
| Ramp out   |     |        |         |         |                     |                     |            | 7                        |       |                |
| Actual speed   |     |        |         |         |                     |                     |            | 8                        |       |                |
| T current ref 1                                      |     |        |         |         |                     |                     |            | 9                        |       |                |
| T current ref 2                                      |     |        |         |         |                     |                     |            | 10                       |       |                |
| T current ref  |     |        |         |         |                     |                     |            | 11                       |       |                |
| Speed reg out  |     |        |         |         |                     |                     |            | 15                       |       |                |
| Motor current  |     |        |         |         |                     |                     |            | 16                       |       |                |
| Output voltage                                       |     |        |         |         |                     |                     |            | 20                       |       |                |
| Analog input 1                                       |     |        |         |         |                     |                     |            | 24                       |       |                |
| Analog input 2                                       |     |        |         |         |                     |                     |            | 25                       |       |                |
| Analog input 3                                       |     |        |         |         |                     |                     |            | 26                       |       |                |
| Flux current   |     |        |         |         |                     |                     |            | 27                       |       |                |
| Pad 0  |     |        |         |         |                     |                     |            | 31                       |       |                |
| Pad 1  |     |        |         |         |                     |                     |            | 32                       |       |                |
| Pad 4  |     |        |         |         |                     |                     |            | 33                       |       |                |
| Pad 5  |     |        |         |         |                     |                     |            | 34                       |       |                |
| Flux reference                                       |     |        |         |         |                     |                     |            | 35                       |       |                |
| Pad 6  |     |        |         |         |                     |                     |            | 38                       |       |                |
| PID output   |     |        |         |         |                     |                     |            | 39                       |       |                |
| Out vlt level  |     |        |         |         |                     |                     |            | 79                       |       |                |
| Flux current max                                     |     |        |         |         |                     |                     |            | 80                       |       |                |
| F act spd  |     |        |         |         |                     |                     |            | 81                       |       |                |
| F T curr   |     |        |         |         |                     |                     |            | 82                       |       |                |
| Speed draw out                                       |     |        |         |         |                     |                     |            | 84                       |       |                |
| Output power   |     |        |         |         |                     |                     |            | 88                       |       |                |
| Roll diameter  |     |        |         |         |                     |                     |            | 89                       |       |                |
| Act tension ref                                      |     |        |         |         |                     |                     |            | 90                       |       |                |
| Torque current                                       |     |        |         |         |                     |                     |            | 91                       |       |                |
| W reference  |     |        |         |         |                     |                     |            | 92                       |       |                |
| Actual comp  |     |        |         |         |                     |                     |            | 93                       |       |                |
| Brake current  |     |        |         |         |                     |                     |            | 94                       |       |                |
| Scale output 1                                       | 62  | Float  | -10.000 | +10.000 | 0.000               | 0.000               | ✓          | R/W                      | -     | -              |
| <b>I/O CONFIG \ Analog outputs \ Analog output 2</b> |     |        |         |         |                     |                     |            |                          |       |                |
| Select output 2<br>(Select like output 1)            | 67  | U16    | 0       | 94      | Motor current (16)  | Motor current (16)  | ✓          | R/Z                      | -     | -              |
| Scale output 2                                       | 63  | Float  | -10.000 | +10000  | 0.000               | 0.000               | ✓          | R/W                      | -     | -              |
| <b>I/O CONFIG \ Analog outputs \ Analog output 3</b> |     |        |         |         |                     |                     |            |                          |       |                |
| Select output 3<br>(Select like output 1)            | 68  | U16    | 0       | 94      | Flux -27            | Flux -27            | ✓          | R/Z                      | -     | -              |
| Scale output 3                                       | 64  | Float  | -10.000 | +10000  | 0.000               | 0.000               | ✓          | R/W                      | -     | -              |
| <b>I/O CONFIG \ Analog outputs \ Analog output 4</b> |     |        |         |         |                     |                     |            |                          |       |                |
| Select output 4<br>(Select like output 1)            | 69  | U16    | 0       | 94      | Output voltage (20) | Output voltage (20) | ✓          | R/Z                      | -     | -              |
| Scale output 4                                       | 65  | Float  | -10.000 | +10000  | 0.000               | 0.000               | ✓          | R/W                      | -     | -              |

| Parameter  | No.  | Format | Value  |        |                   |                   | Access via |                          |       |                |
|--|------|--------|--------|--------|-------------------|-------------------|------------|--------------------------|-------|----------------|
|  |      |        | min    | max    | Factory American  | Factory European  | Keyp.      | RS485/<br>BUS/<br>Opt2-M | Term. | Opt2-A/<br>PDC |
| <b>I/O CONFIG \ Analog inputs \ Analog input 1</b> |      |        |        |        |                   |                   |            |                          |       |                |
| Select input 1                                     | 70   | U16    | 0      | 32     | Ramp ref<br>1 (4) | Ramp ref<br>1 (4) | ✓          | R/Z                      | -     | -              |
| OFF  |      |        |        |        |                   |                   |            | 0                        |       |                |
| Jog reference                                      |      |        |        |        |                   |                   |            | 1                        |       |                |
| Speed ref 1  |      |        |        |        |                   |                   |            | 2                        |       |                |
| Speed ref 2  |      |        |        |        |                   |                   |            | 3                        |       |                |
| Ramp ref 1   |      |        |        |        |                   |                   |            | 4                        |       |                |
| Ramp ref 2   |      |        |        |        |                   |                   |            | 5                        |       |                |
| T current ref 1                                    |      |        |        |        |                   |                   |            | 6                        |       |                |
| T current ref 2                                    |      |        |        |        |                   |                   |            | 7                        |       |                |
| Adap reference                                     |      |        |        |        |                   |                   |            | 8                        |       |                |
| T current limit                                    |      |        |        |        |                   |                   |            | 9                        |       |                |
| T current lim +                                    |      |        |        |        |                   |                   |            | 10                       |       |                |
| T current lim -                                    |      |        |        |        |                   |                   |            | 11                       |       |                |
| Pad 0  |      |        |        |        |                   |                   |            | 12                       |       |                |
| Pad 1  |      |        |        |        |                   |                   |            | 13                       |       |                |
| Pad 2  |      |        |        |        |                   |                   |            | 14                       |       |                |
| Pad 3  |      |        |        |        |                   |                   |            | 15                       |       |                |
| Load comp  |      |        |        |        |                   |                   |            | 19                       |       |                |
| PID offset 0                                       |      |        |        |        |                   |                   |            | 21                       |       |                |
| PI central v3                                      |      |        |        |        |                   |                   |            | 22                       |       |                |
| PID feed-back                                      |      |        |        |        |                   |                   |            | 23                       |       |                |
| Flux current max<br>(Max field curr)               |      |        |        |        |                   |                   |            | 25                       |       |                |
| Out vlt level                                      |      |        |        |        |                   |                   |            | 26                       |       |                |
| Speed ratio  |      |        |        |        |                   |                   |            | 28                       |       |                |
| Tension red  |      |        |        |        |                   |                   |            | 29                       |       |                |
| Tension ref  |      |        |        |        |                   |                   |            | 30                       |       |                |
| Preset 3   |      |        |        |        |                   |                   |            | 31                       |       |                |
| Brake Ref  |      |        |        |        |                   |                   |            | 32                       |       |                |
| An in 1 target                                     | 295  | U16    | 0      | 1      | 0                 | 0                 | ✓          | R/W                      | ID    | R/W            |
| Assigned   |      |        |        |        |                   |                   |            | 0                        | L     | 0              |
| Not assigned                                       |      |        |        |        |                   |                   |            | 1                        | H     | 1              |
| Input 1 type                                       | 71   | U16    | 0      | 2      | ± 10 V            | ± 10 V            | ✓          | R/Z                      | -     | -              |
| -10V ... + 10 V                                    |      |        |        |        |                   |                   |            | 0                        |       |                |
| 0...20 mA, 0...10 V                                |      |        |        |        |                   |                   |            | 1                        |       |                |
| 4...20 mA  |      |        |        |        |                   |                   |            | 2                        |       |                |
| Input 1 sign                                       | 389  | U16    | 0      | 1      | 1                 | 1                 | ✓          | R/W                      | -     | R/W            |
| Positive   |      |        |        |        |                   |                   |            | 1                        |       | 1              |
| Negative   |      |        |        |        |                   |                   |            | 0                        |       | 0              |
| Scale input 1                                      | 72   | Float  | -10000 | +10000 | 1.000             | 1.000             | ✓          | R/W                      | -     | -              |
| Tune value inp 1                                   | 73   | Float  | 0.100  | 10.000 | 1.000             | 1.000             | ✓          | R/W                      | -     | -              |
| Auto tune inp 1                                    | 259  | U16    |        |        |                   |                   | ✓          | C/W                      | -     | -              |
| Auto tune  |      |        |        |        |                   |                   |            | 1                        |       |                |
| Input 1 filter [ms]                                | 792  | U16    | 0      | 1000   | 0                 | 0                 | ✓          | R/W                      | -     | R/W            |
| Input 1 compare                                    | 1042 | I16    | -10000 | +10000 | 0                 | 0                 | ✓          | R/W                      | -     | -              |
| Input 1 cp error                                   | 1043 | U16    | 0      | 10000  | 0                 | 0                 | ✓          | R/W                      | -     | -              |
| Input 1 cp delay                                   | 1044 | U16    | 0      | 65000  | 0                 | 0                 | ✓          | R/W                      | -     | -              |
| Input 1 cp match                                   | 1045 | U16    | 0      | 1      | -                 | -                 | -          | R                        | QD    | R              |
| Input 1 not thr.val.                               |      |        |        |        |                   |                   |            | 0                        | L     |                |
| Input 1=thr.val                                    |      |        |        |        |                   |                   |            | 1                        | H     |                |
| Offset input 1                                     | 74   | I16    | -32768 | +32767 | 0                 | 0                 | ✓          | R/W                      | -     | -              |

| Parameter   | No. | Format | Value   |        |                  |                  | Access via |                          |       |                |
|---|-----|--------|---------|--------|------------------|------------------|------------|--------------------------|-------|----------------|
|   |     |        | min     | max    | Factory American | Factory European | Keyp.      | RS485/<br>BUS/<br>Opt2-M | Term. | Opt2-A/<br>PDC |
| <b>I/O CONFIG \ Analog inputs \ Analog input 2</b>                  |     |        |         |        |                  |                  |            |                          |       |                |
| Select input 2<br>(Select like Input 1)                             | 75  | U16    | 0       | 32     | OFF (0)          | OFF (0)          | ✓          | R/Z                      | -     | -              |
| An in 2 target  | 296 | U16    | 0       | 1      | 0                | 0                | ✓          | R/W                      | ID    | R/W            |
| Assigned  |     |        |         |        |                  |                  |            | 0                        | L     | 0              |
| Not assigned  | 1   | H      | 1       |        |                  |                  |            |                          |       |                |
| Input 2 type<br>-10V ... + 10 V<br>0...20 mA, 0...10 V<br>4...20 mA | 76  | U16    | 0       | 2      | ± 10 V           | ± 10 V           | ✓          | R/Z                      | -     | -              |
| Input 2 sign  | 390 | U16    | 0       | 1      | 1                | 1                | ✓          | R/W                      | -     | R/W            |
| Positive  |     |        |         |        |                  |                  |            | 1                        | -     | 1              |
| Negative  | 0   | -      | 0       |        |                  |                  |            |                          |       |                |
| Scale input 2   | 77  | Float  | -10.000 | +10000 | 1.000            | 1.000            | ✓          | R/W                      | -     | -              |
| Tune value inp 2  | 78  | Float  | 0.100   | 10.000 | 1.000            | 1.000            | ✓          | R/W                      | -     | -              |
| Auto tune inp 2   | 260 | U16    |         |        |                  |                  | ✓          | C/W                      | -     | -              |
| Auto tune   |     |        |         |        |                  |                  |            | 1                        | -     | -              |
| Input 2 filter [ms]   | 801 | U16    | 0       | 1000   | 0                | 0                | ✓          | R/W                      | -     | R/W            |
| Offset input 2  | 79  | I16    | -32768  | +32767 | 0                | 0                | ✓          | R/W                      | -     | -              |
| <b>I/O CONFIG \ Analog inputs \ Analog input 3</b>                  |     |        |         |        |                  |                  |            |                          |       |                |
| Select input 3<br>(Select like Input 1)                             | 80  | U16    | 0       | 32     | OFF (0)          | OFF (0)          | ✓          | R/Z                      | -     | -              |
| An in 3 target  | 297 | U16    | 0       | 1      | 0                | 0                | ✓          | R/W                      | ID    | R/W            |
| Assigned  |     |        |         |        |                  |                  |            | 0                        | L     | 0              |
| Not assigned  | 1   | H      | 1       |        |                  |                  |            |                          |       |                |
| Input 3 type<br>-10V ... + 10 V<br>0...20 mA, 0...10 V<br>4...20 mA | 81  | U16    | 0       | 2      | ± 10 V           | ± 10 V           | ✓          | R/Z                      | -     | -              |
| Input 3 sign  | 391 | U16    | 0       | 1      | 1                | 1                | ✓          | R/W                      | -     | R/W            |
| Positive  |     |        |         |        |                  |                  |            | 1                        | -     | 1              |
| Negative  | 0   | -      | 0       |        |                  |                  |            |                          |       |                |
| Scale input 3   | 82  | Float  | -10.000 | +10000 | 1.000            | 1.000            | ✓          | R/W                      | -     | -              |
| Tune value inp 3  | 83  | Float  | 0.100   | 10.000 | 1.000            | 1.000            | ✓          | R/W                      | -     | -              |
| Auto tune inp 3   | 261 | U16    |         |        |                  |                  | ✓          | C/W                      | -     | -              |
| Auto tune   |     |        |         |        |                  |                  |            | 1                        | -     | -              |
| Input 3 filter [ms]   | 802 | U16    | 0       | 1000   | 0                | 0                | ✓          | R/W                      | -     | R/W            |
| Offset input 3  | 84  | I16    | -32768  | +32767 | 0                | 0                | ✓          | R/W                      | -     | -              |

| Parameter                                  | No.  | Format | Value |     |                      |                      | Access via |                          |       |                |
|--|------|--------|-------|-----|----------------------|----------------------|------------|--------------------------|-------|----------------|
|  |      |        | min   | max | Factory American     | Factory European     | Keyp.      | RS485/<br>BUS/<br>Opt2-M | Term. | Opt2-A/<br>PDC |
| <b>I/O CONFIG \ Digital outputs</b>        |      |        |       |     |                      |                      |            |                          |       |                |
| Digital output 1                           | 145  | U16    | 0     | 77  | Ramp +<br>(8)        | Ramp +<br>(8)        | ✓          | R/Z                      | -     | -              |
| OFF  |      |        |       |     |                      |                      |            | 0                        |       |                |
| Speed zero thr                             |      |        |       |     |                      |                      |            | 1                        |       |                |
| Spd threshold                              |      |        |       |     |                      |                      |            | 2                        |       |                |
| Set speed                                  |      |        |       |     |                      |                      |            | 3                        |       |                |
| Curr limit state                           |      |        |       |     |                      |                      |            | 4                        |       |                |
| Drive ready                                |      |        |       |     |                      |                      |            | 5                        |       |                |
| Mot ovrlid avail                           |      |        |       |     |                      |                      |            | 6                        |       |                |
| Overload state                             |      |        |       |     |                      |                      |            | 7                        |       |                |
| Ramp +                                     |      |        |       |     |                      |                      |            | 8                        |       |                |
| Ramp -                                     |      |        |       |     |                      |                      |            | 9                        |       |                |
| Speed limited                              |      |        |       |     |                      |                      |            | 10                       |       |                |
| Undervoltage                               |      |        |       |     |                      |                      |            | 11                       |       |                |
| Overvoltage                                |      |        |       |     |                      |                      |            | 12                       |       |                |
| Heatsink                                   |      |        |       |     |                      |                      |            | 13                       |       |                |
| Overcurrent                                |      |        |       |     |                      |                      |            | 14                       |       |                |
| Overtemp motor                             |      |        |       |     |                      |                      |            | 15                       |       |                |
| External fault                             |      |        |       |     |                      |                      |            | 16                       |       |                |
| Failure supply                             |      |        |       |     |                      |                      |            | 17                       |       |                |
| Pad A bit                                  |      |        |       |     |                      |                      |            | 18                       |       |                |
| Pad B bit                                  |      |        |       |     |                      |                      |            | 19                       |       |                |
| Virt dig input                             |      |        |       |     |                      |                      |            | 20                       |       |                |
| Torque sign                                |      |        |       |     |                      |                      |            | 21                       |       |                |
| Stop control                               |      |        |       |     |                      |                      |            | 23                       |       |                |
| Field loss                                 |      |        |       |     |                      |                      |            | 24                       |       |                |
| Speed fbk loss                             |      |        |       |     |                      |                      |            | 25                       |       |                |
| Bus loss                                   |      |        |       |     |                      |                      |            | 26                       |       |                |
| Hw opt1 failure                            |      |        |       |     |                      |                      |            | 28                       |       |                |
| Opt2 failure                               |      |        |       |     |                      |                      |            | 29                       |       |                |
| Encoder 1 state                            |      |        |       |     |                      |                      |            | 30                       |       |                |
| Encoder 2 state                            |      |        |       |     |                      |                      |            | 31                       |       |                |
| Enable seq err                             |      |        |       |     |                      |                      |            | 35                       |       |                |
| Diameter calc st                           |      |        |       |     |                      |                      |            | 38                       |       |                |
| Drive healthy                              |      |        |       |     |                      |                      |            | 42                       |       |                |
| Input 1 cp match                           |      |        |       |     |                      |                      |            | 49                       |       |                |
| Diam reached                               |      |        |       |     |                      |                      |            | 58                       |       |                |
| Spd match compl                            |      |        |       |     |                      |                      |            | 59                       |       |                |
| Acc state                                  |      |        |       |     |                      |                      |            | 60                       |       |                |
| Dec state                                  |      |        |       |     |                      |                      |            | 61                       |       |                |
| Brake comand                               |      |        |       |     |                      |                      |            | 62                       |       |                |
| Brake failure                              |      |        |       |     |                      |                      |            | 63                       |       |                |
| Mot ovrlid preal                           |      |        |       |     |                      |                      |            | 65                       |       |                |
| Dvr ovrlid preal                           |      |        |       |     |                      |                      |            | 66                       |       |                |
| Dvr ovrlid avail                           |      |        |       |     |                      |                      |            | 67                       |       |                |
| I2t mot ovrlid fail                        |      |        |       |     |                      |                      |            | 68                       |       |                |
| I2t drv ovrlid fail                        |      |        |       |     |                      |                      |            | 69                       |       |                |
| Mot cur threshld                           |      |        |       |     |                      |                      |            | 70                       |       |                |
| Overspeed                                  |      |        |       |     |                      |                      |            | 71                       |       |                |
| Delta frequency                            |      |        |       |     |                      |                      |            | 72                       |       |                |
| Drv rdy to start                           |      |        |       |     |                      |                      |            | 76                       |       |                |
| BUS control mode                           |      |        |       |     |                      |                      |            | 77                       |       |                |
| Inversion out 1                            | 1267 | U16    | 0     | 1   | Disabled<br>(0)      | Disabled<br>(0)      | ✓          | R/W                      | -     | -              |
| Enabled                                    |      |        |       |     |                      |                      |            | 1                        |       |                |
| Disabled                                   |      |        |       |     |                      |                      |            | 0                        |       |                |
| Digital output 2<br>(Select like output 1) | 146  | U16    | 0     | 77  | Ramp -<br>(9)        | Ramp -<br>(9)        | ✓          | R/Z                      | -     | -              |
| Inversion out 2                            | 1268 | U16    | 0     | 1   | Disabled<br>(0)      | Disabled<br>(0)      | ✓          | R/W                      | -     | -              |
| Enabled                                    |      |        |       |     |                      |                      |            | 1                        |       |                |
| Disabled                                   |      |        |       |     |                      |                      |            | 0                        |       |                |
| Digital output 3<br>(Select like output 1) | 147  | U16    | 0     | 77  | Spd thr.<br>(2)      | Spd thr.<br>(2)      | ✓          | R/Z                      | -     | -              |
| Inversion out 3                            | 1269 | U16    | 0     | 1   | Disabled<br>(0)      | Disabled<br>(0)      | ✓          | R/W                      | -     | -              |
| Enabled                                    |      |        |       |     |                      |                      |            | 1                        |       |                |
| Disabled                                   |      |        |       |     |                      |                      |            | 0                        |       |                |
| Digital output 4<br>(Select like output 1) | 148  | U16    | 0     | 77  | Overld<br>avail. (6) | Overld<br>avail. (6) | ✓          | R/Z                      | -     | -              |

| Parameter                                  | No.  | Format | Value |     |                           |                           | Access via |                          |       |                |
|--|------|--------|-------|-----|---------------------------|---------------------------|------------|--------------------------|-------|----------------|
|  |      |        | min   | max | Factory American          | Factory European          | Key.       | RS485/<br>BUS/<br>Opt2-M | Term. | Opt2-A/<br>PDC |
| Inversion out 4<br>Enabled<br>Disabled     | 1270 | U16    | 0     | 1   | Disabled<br>(0)           | Disabled<br>(0)           | ✓          | R/W<br>1<br>0            | -     | -              |
| Digital output 5<br>(Select like output 1) | 149  | U16    | 0     | 77  | Curr lim.<br>state (4)    | Curr lim.<br>state (4)    | ✓          | R/Z                      | -     | -              |
| Inversion out 5<br>Enabled<br>Disabled     | 1271 | U16    | 0     | 1   | Disabled<br>(0)           | Disabled<br>(0)           | ✓          | R/W<br>1<br>0            | -     | -              |
| Digital output 6<br>(Select like output 1) | 150  | U16    | 0     | 77  | Over-<br>voltage<br>(12)  | Over-<br>voltage<br>(12)  | ✓          | R/Z                      | -     | -              |
| Inversion out 6<br>Enabled<br>Disabled     | 1272 | U16    | 0     | 1   | Disabled<br>(0)           | Disabled<br>(0)           | ✓          | R/W<br>1<br>0            | -     | -              |
| Digital output 7<br>(Select like output 1) | 151  | U16    | 0     | 77  | Under-<br>voltage<br>(11) | Under-<br>voltage<br>(11) | ✓          | R/Z                      | -     | -              |
| Inversion out 7<br>Enabled<br>Disabled     | 1273 | U16    | 0     | 1   | Disabled<br>(0)           | Disabled<br>(0)           | ✓          | R/W<br>1<br>0            | -     | -              |
| Digital output 8<br>(Select like output 1) | 152  | U16    | 0     | 77  | Over-cur-<br>rent (14)    | Over-cur-<br>rent (14)    | ✓          | R/Z                      | -     | -              |
| Inversion out 8<br>Enabled<br>Disabled     | 1274 | U16    | 0     | 1   | Disabled<br>(0)           | Disabled<br>(0)           | ✓          | R/W<br>1<br>0            | -     | -              |
| Relay 2<br>(Select like output 1)          | 629  | U16    | 0     | 77  | Stop ctrl<br>(23)         | Stop ctrl<br>(23)         | ✓          | R/Z                      | -     | -              |
| Inversion relay 2<br>Enabled<br>Disabled   | 1275 | U16    | 0     | 1   | Disabled<br>(0)           | Disabled<br>(0)           | ✓          | R/W<br>1<br>0            | -     | -              |

| Parameter                                | No.  | Format | Value |     |                  |                  | Access via |                          |       |                |
|--|------|--------|-------|-----|------------------|------------------|------------|--------------------------|-------|----------------|
|  |      |        | min   | max | Factory American | Factory European | Keyp.      | RS485/<br>BUS/<br>Opt2-M | Term. | Opt2-A/<br>PDC |
| <b>I/O CONFIG \ Digital inputs</b>       |      |        |       |     |                  |                  |            |                          |       |                |
| Digital input 1                          | 137  | U16    | 0     | 87  | OFF (0)          | OFF (0)          |            | R/Z                      | -     | -              |
| OFF                                      |      |        |       |     |                  |                  |            | 0                        |       |                |
| Motor pot reset                          |      |        |       |     |                  |                  |            | 1                        |       |                |
| Motor pot up                             |      |        |       |     |                  |                  |            | 2                        |       |                |
| Motor pot down                           |      |        |       |     |                  |                  |            | 3                        |       |                |
| Motor pot sign +                         |      |        |       |     |                  |                  |            | 4                        |       |                |
| Motor pot sign -                         |      |        |       |     |                  |                  |            | 5                        |       |                |
| Jog +                                    |      |        |       |     |                  |                  |            | 6                        |       |                |
| Jog -                                    |      |        |       |     |                  |                  |            | 7                        |       |                |
| Failure reset                            |      |        |       |     |                  |                  |            | 8                        |       |                |
| Torque reduct                            |      |        |       |     |                  |                  |            | 9                        |       |                |
| Ramp out = 0                             |      |        |       |     |                  |                  |            | 10                       |       |                |
| Ramp in = 0                              |      |        |       |     |                  |                  |            | 11                       |       |                |
| Freeze ramp                              |      |        |       |     |                  |                  |            | 12                       |       |                |
| Lock speed reg                           |      |        |       |     |                  |                  |            | 13                       |       |                |
| Lock speed I                             |      |        |       |     |                  |                  |            | 14                       |       |                |
| Auto capture                             |      |        |       |     |                  |                  |            | 15                       |       |                |
| Input 1 sign +                           |      |        |       |     |                  |                  |            | 16                       |       |                |
| Input 1 sign -                           |      |        |       |     |                  |                  |            | 17                       |       |                |
| Input 2 sign +                           |      |        |       |     |                  |                  |            | 18                       |       |                |
| Input 2 sign -                           |      |        |       |     |                  |                  |            | 19                       |       |                |
| Input 3 sign +                           |      |        |       |     |                  |                  |            | 20                       |       |                |
| Input 3 sign -                           |      |        |       |     |                  |                  |            | 21                       |       |                |
| Zero torque                              |      |        |       |     |                  |                  |            | 22                       |       |                |
| Speed sel 0                              |      |        |       |     |                  |                  |            | 23                       |       |                |
| Speed sel 1                              |      |        |       |     |                  |                  |            | 24                       |       |                |
| Speed sel 2                              |      |        |       |     |                  |                  |            | 25                       |       |                |
| Ramp sel 0                               |      |        |       |     |                  |                  |            | 26                       |       |                |
| Ramp sel 1                               |      |        |       |     |                  |                  |            | 27                       |       |                |
| Field loss                               |      |        |       |     |                  |                  |            | 29                       |       |                |
| Enable flux reg                          |      |        |       |     |                  |                  |            | 30                       |       |                |
| Enable flux weak                         |      |        |       |     |                  |                  |            | 31                       |       |                |
| Pad A bit 0                              |      |        |       |     |                  |                  |            | 32                       |       |                |
| Pad A bit 1                              |      |        |       |     |                  |                  |            | 33                       |       |                |
| Pad A bit 2                              |      |        |       |     |                  |                  |            | 34                       |       |                |
| Pad A bit 3                              |      |        |       |     |                  |                  |            | 35                       |       |                |
| Pad A bit 4                              |      |        |       |     |                  |                  |            | 36                       |       |                |
| Pad A bit 5                              |      |        |       |     |                  |                  |            | 37                       |       |                |
| Pad A bit 6                              |      |        |       |     |                  |                  |            | 38                       |       |                |
| Pad A bit 7                              |      |        |       |     |                  |                  |            | 39                       |       |                |
| Forward sign                             |      |        |       |     |                  |                  |            | 44                       |       |                |
| Reverse sign                             |      |        |       |     |                  |                  |            | 45                       |       |                |
| An in 1 target                           |      |        |       |     |                  |                  |            | 46                       |       |                |
| An in 2 target                           |      |        |       |     |                  |                  |            | 47                       |       |                |
| An in 3 target                           |      |        |       |     |                  |                  |            | 48                       |       |                |
| Enable droop                             |      |        |       |     |                  |                  |            | 49                       |       |                |
| Enable PI PID                            |      |        |       |     |                  |                  |            | 52                       |       |                |
| Enable PD PID                            |      |        |       |     |                  |                  |            | 53                       |       |                |
| PI integral freeze                       |      |        |       |     |                  |                  |            | 54                       |       |                |
| PID offs. Sel                            |      |        |       |     |                  |                  |            | 55                       |       |                |
| PI central vs0                           |      |        |       |     |                  |                  |            | 56                       |       |                |
| PI central vs1                           |      |        |       |     |                  |                  |            | 57                       |       |                |
| Diameter calc                            |      |        |       |     |                  |                  |            | 58                       |       |                |
| Diam reset                               |      |        |       |     |                  |                  |            | 68                       |       |                |
| Diam calc Dis                            |      |        |       |     |                  |                  |            | 69                       |       |                |
| Torque winder EN                         |      |        |       |     |                  |                  |            | 70                       |       |                |
| Line acc status                          |      |        |       |     |                  |                  |            | 71                       |       |                |
| Line dec status                          |      |        |       |     |                  |                  |            | 72                       |       |                |
| Line fstp status                         |      |        |       |     |                  |                  |            | 73                       |       |                |
| Speed match                              |      |        |       |     |                  |                  |            | 74                       |       |                |
| Diam inc/dec En                          |      |        |       |     |                  |                  |            | 75                       |       |                |
| Wind/unwind                              |      |        |       |     |                  |                  |            | 76                       |       |                |
| Diam preset sel0                         |      |        |       |     |                  |                  |            | 77                       |       |                |
| Diam preset sel1                         |      |        |       |     |                  |                  |            | 78                       |       |                |
| Taper enable                             |      |        |       |     |                  |                  |            | 79                       |       |                |
| Speed demand En                          |      |        |       |     |                  |                  |            | 80                       |       |                |
| Winder side                              |      |        |       |     |                  |                  |            | 81                       |       |                |
| Enable PI-PD PID                         |      |        |       |     |                  |                  |            | 82                       |       |                |
| Jog TW enable                            |      |        |       |     |                  |                  |            | 83                       |       |                |
| Brake fbk                                |      |        |       |     |                  |                  |            | 84                       |       |                |
| Adapt Sel 1                              |      |        |       |     |                  |                  |            | 86                       |       |                |
| Adapt Sel 2                              |      |        |       |     |                  |                  |            | 87                       |       |                |
| Inversion in 1                           | 1276 | U16    | 0     | 1   | Disabled (0)     | Disabled (0)     | ✓          | R/W                      | -     | -              |
| Enabled                                  |      |        |       |     |                  |                  |            | 1                        |       |                |
| Disabled                                 |      |        |       |     |                  |                  |            | 0                        |       |                |
| Digital input 2<br>(Select like input 1) | 138  | U16    | 0     | 87  | OFF (0)          | OFF (0)          | ✓          | R/Z                      | -     | -              |

| Parameter   | No.  | Format | Value |      |                           |                           | Access via |                              |       |                |
|---|------|--------|-------|------|---------------------------|---------------------------|------------|------------------------------|-------|----------------|
|   |      |        | min   | max  | Factory American          | Factory European          | Keyp.      | RS485/<br>BUS/<br>Opt2-M     | Term. | Opt2-A/<br>PDC |
| Inversion in 2<br>Enabled<br>Disabled   | 1277 | U16    | 0     | 1    | Disabled<br>(0)           | Disabled<br>(0)           | ✓          | R/W<br>1<br>0                | -     | -              |
| Digital input 3<br>(Select like input 1)                                      | 139  | U16    | 0     | 87   | OFF (0)                   | OFF (0)                   | ✓          | R/Z                          | -     | -              |
| Inversion in 3<br>Enabled<br>Disabled   | 1278 | U16    | 0     | 1    | Disabled<br>(0)           | Disabled<br>(0)           | ✓          | R/W<br>1<br>0                | -     | -              |
| Digital input 4<br>(Select like input 1)                                      | 140  | U16    | 0     | 87   | OFF (0)                   | OFF (0)                   | ✓          | R/Z                          | -     | -              |
| Inversion in 4<br>Enabled<br>Disabled   | 1279 | U16    | 0     | 1    | Disabled<br>(0)           | Disabled<br>(0)           | ✓          | R/W<br>1<br>0                | -     | -              |
| Digital input 5<br>(Select like input 1)                                      | 141  | U16    | 0     | 87   | OFF (0)                   | OFF (0)                   | ✓          | R/Z                          | -     | -              |
| Inversion in 5<br>Enabled<br>Disabled   | 1280 | U16    | 0     | 1    | Disabled<br>(0)           | Disabled<br>(0)           | ✓          | R/W<br>1<br>0                | -     | -              |
| Digital input 6<br>(Select like input 1)                                      | 142  | U16    | 0     | 87   | OFF (0)                   | OFF (0)                   | ✓          | R/Z                          | -     | -              |
| Inversion in 6<br>Enabled<br>Disabled   | 1281 | U16    | 0     | 1    | Disabled<br>(0)           | Disabled<br>(0)           | ✓          | R/W<br>1<br>0                | -     | -              |
| Digital input 7<br>(Select like input 1)                                      | 143  | U16    | 0     | 87   | OFF (0)                   | OFF (0)                   | ✓          | R/Z                          | -     | -              |
| Inversion in 7<br>Enabled<br>Disabled   | 1282 | U16    | 0     | 1    | Disabled<br>(0)           | Disabled<br>(0)           | ✓          | R/W<br>1<br>0                | -     | -              |
| Digital input 8<br>(Select like input 1)                                      | 144  | U16    | 0     | 87   | OFF (0)                   | OFF (0)                   | ✓          | R/Z                          | -     | -              |
| Inversion in 8<br>Enabled<br>Disabled   | 1283 | U16    | 0     | 1    | Disabled<br>(0)           | Disabled<br>(0)           | ✓          | R/W<br>1<br>0                | -     | -              |
| <b>I/O CONFIG \ Encoder inputs</b>  |      |        |       |      |                           |                           |            |                              |       |                |
| Select enc 1<br>OFF<br>Speed ref 1<br>Speed ref 2<br>Ramp ref 1<br>Ramp ref 2 | 1020 | U16    | 0     | 5    | OFF<br>(0)<br>see 6.12.05 | OFF<br>(0)<br>see 6.12.05 | ✓          | R/Z<br>0<br>2<br>3<br>4<br>5 | -     | -              |
| Select enc 2<br>OFF<br>Speed ref 1<br>Speed ref 2<br>Ramp ref 1<br>Ramp ref 2 | 1021 | U16    | 0     | 5    | OFF<br>(0)<br>see 6.12.05 | OFF<br>(0)<br>see 6.12.05 | ✓          | R/Z<br>0<br>2<br>3<br>4<br>5 | -     | -              |
| Encoder 1 pulses  | 416  | Float* | 600   | 9999 | 1024                      | 1024                      | ✓          | R/Z                          | -     | R              |
| Encoder 2 pulses  | 169  | Float* | 150   | 9999 | 1024                      | 1024                      | ✓          | R/Z                          | -     | R              |
| Refresh enc 1<br>Enabled<br>Disabled  | 649  | U16    | 0     | 1    | Disabled<br>(0)           | Disabled<br>(0)           | ✓          | R/W<br>1<br>0                | -     | -              |
| Refresh enc 2<br>Enabled<br>Disabled  | 652  | U16    | 0     | 1    | Disabled<br>(0)           | Disabled<br>(0)           | ✓          | R/W<br>1<br>0                | -     | -              |



| Parameter  | No.  | Format | Value  |        |                  |                  | Access via |                          |                  |                |
|--|------|--------|--------|--------|------------------|------------------|------------|--------------------------|------------------|----------------|
|  |      |        | min    | max    | Factory American | Factory European | Keyp.      | RS485/<br>BUS/<br>Opt2-M | Term.            | Opt2-A/<br>PDC |
| <b>ADD SPEED FUNCT</b>                                   |      |        |        |        |                  |                  |            |                          |                  |                |
| Auto capture<br>ON<br>OFF                                | 388  | U16    |        |        | OFF<br>(0)       | OFF<br>(0)       | ✓          | R/W<br><br>1<br>0        | ID<br><br>H<br>L | -              |
| <b>ADD SPEED FUNCT \ Adaptive spd reg</b>                |      |        |        |        |                  |                  |            |                          |                  |                |
| Enable spd adap<br>Enabled<br>Disabled                   | 181  | U16    | 0      | 1      | Disabled         | Disabled         | ✓          | R/Z<br>1<br>0            | -                | -              |
| Select adap type<br>Speed<br>Adap reference<br>Parameter | 182  | U16    | 0      | 2      | Speed            | Speed            | ✓          | R/Z<br>0<br>1<br>2       | -                | -              |
| Adap reference [FF]                                      | 183  | I16    | -32768 | +32767 | 1000             | 1000             | ✓          | R/W                      | IA               | R/W            |
| Adap selector  | 1464 | U16    | 0      | 3      | 0                | 0                | ✓          | R/W                      | -                | -              |
| Adap speed 1 [%]   | 184  | Float  | 0.0    | 200.0  | 20.3             | 20.3             | ✓          | R/W                      | -                | -              |
| Adap speed 2 [%]   | 185  | Float  | 0.0    | 200.0  | 40.7             | 40.7             | ✓          | R/W                      | -                | -              |
| Adap joint 1 [%]   | 186  | Float  | 0.0    | 200.0  | 6.1              | 6.1              | ✓          | R/W                      | -                | -              |
| Adap joint 2 [%]   | 187  | Float  | 0.0    | 200.0  | 6.1              | 6.1              | ✓          | R/W                      | -                | -              |
| Adap P gain 1 [%]  | 188  | Float  | 0.00   | 100.00 | 10.00            | 10.00            | ✓          | R/W                      | -                | -              |
| Adap I gain 1 [%]  | 189  | Float  | 0.00   | 100.00 | 1.00             | 1.00             | ✓          | R/W                      | -                | -              |
| Adap P gain 2 [%]  | 190  | Float  | 0.00   | 100.00 | 10.00            | 10.00            | ✓          | R/W                      | -                | -              |
| Adap I gain 2 [%]  | 191  | Float  | 0.00   | 100.00 | 1.00             | 1.00             | ✓          | R/W                      | -                | -              |
| Adap P gain 3 [%]  | 192  | Float  | 0.00   | 100.00 | 10.00            | 10.00            | ✓          | R/W                      | -                | -              |
| Adap I gain 3 [%]  | 193  | Float  | 0.00   | 100.00 | 1.00             | 1.00             | ✓          | R/W                      | -                | -              |
| Adap P gain 4 [%]  | 1462 | Float  | 0.00   | 100.00 | 10.00            | 10.00            | ✓          | R/W                      | -                | -              |
| Adap I gain 4 [%]  | 1463 | Float  | 0.00   | 100.00 | 1.00             | 1.00             | ✓          | R/W                      | -                | -              |
| <b>ADD SPEED FUNCT \ Speed control</b>                   |      |        |        |        |                  |                  |            |                          |                  |                |
| Spd threshold + [FF]                                     | 101  | U16    | 1      | 32767  | 1000             | 1000             | ✓          | R/W                      | -                | -              |
| Spd threshold - [FF]                                     | 102  | U16    | 1      | 32767  | 1000             | 1000             | ✓          | R/W                      | -                | -              |
| Threshold delay [ms]                                     | 103  | U16    | 0      | 65535  | 100              | 100              | ✓          | R/W                      | -                | -              |
| Spd threshold<br>Speed exceeded<br>Speed not exceeded    | 393  | U16    | 0      | 1      |                  |                  | -          | R<br>0<br>1              | QD<br>L<br>H     | R<br>0<br>1    |
| Set error [FF]   | 104  | U16    | 1      | 32767  | 100              | 100              | ✓          | R/W                      | -                | -              |
| Set delay [ms]   | 105  | U16    | 1      | 65535  | 100              | 100              | ✓          | R/W                      | -                | -              |
| Set speed<br>Speed not ref. val.<br>Speed = ref. val.    | 394  | U16    | 0      | 1      |                  |                  | -          | R<br>0<br>1              | QD<br>L<br>H     | R<br>0<br>1    |
| <b>ADD SPEED FUNCT \ Speed zero</b>                      |      |        |        |        |                  |                  |            |                          |                  |                |
| Speed zero level [FF]                                    | 107  | U16    | 1      | 32767  | 10               | 10               | ✓          | R/W                      | -                | -              |
| Speed zero delay [ms]                                    | 108  | U16    | 0      | 65535  | 100              | 100              | ✓          | R/W                      | -                | -              |
| Speed zero thr<br>Drive not rotating<br>Drive rotating   | 395  | U16    | 0      | 1      |                  |                  | -          | R<br>0<br>1              | QD<br>L<br>H     | R<br>0<br>1    |
| <b>FUNCTIONS \ Motor pot</b>                             |      |        |        |        |                  |                  |            |                          |                  |                |
| Enable motor pot<br>Enabled<br>Disabled                  | 246  | I16    | 0      | 1      | Disabled         | Disabled         | ✓          | R/Z<br>1<br>0            | -                | -              |
| Motor pot oper   | 247  |        |        |        |                  |                  | ✓          | -                        | -                | -              |
| Motor pot sign<br>Positive<br>Negative                   | 248  | I16    | 0      | 1      | Positive         | Positive         | ✓          | R/W<br>1<br>0            | ID               | -              |
| Motor pot reset  | 249  | U16    |        |        |                  |                  | ✓          | Z/C(1)                   | ID (H)           | -              |
| Motor pot up<br>No acceleration<br>Acceleration          | 396  | U16    | 0      | 1      |                  |                  |            | R/W<br>0<br>1            | ID<br>L<br>H     | R/W<br>0<br>1  |
| Motor pot down<br>No deceleration<br>Deceleration        | 397  | U16    | 0      | 1      |                  |                  |            | R/W<br>0<br>1            | ID<br>L<br>H     | R/W<br>0<br>1  |

| Parameter   | No. | Format | Value  |                    |                  |                  | Access via |                          |              |                |  |
|---|-----|--------|--------|--------------------|------------------|------------------|------------|--------------------------|--------------|----------------|--|
|   |     |        | min    | max                | Factory American | Factory European | Keyp.      | RS485/<br>BUS/<br>Opt2-M | Term.        | Opt2-A/<br>PDC |  |
| <b>FUNCTIONS \ Jog function</b>   |     |        |        |                    |                  |                  |            |                          |              |                |  |
| Enable jog<br>Enabled<br>Disabled   | 244 | I16    | 0      | 1                  | Disabled         | Disabled         | ✓          | R/Z<br>1<br>0            | -            | -              |  |
| Jog operation   | 265 | -      | -      | -                  | -                | -                | ✓          | -                        | -            | -              |  |
| Jog selection<br>Speed input<br>Ramp input  | 375 | U16    | 0      | 1                  | 0                | 0                | ✓          | R/Z<br>0<br>1            | -            | -              |  |
| Jog reference [FF]  | 266 | I16    | 0      | 32767              | 0                | 0                | ✓          | R/W                      | IA           | -              |  |
| Jog +<br>No jog forwards<br>Forwards jog  | 398 | U16    | 0      | 1                  |                  |                  |            | R/W<br>0<br>1            | ID<br>L<br>H | R/W<br>0<br>1  |  |
| Jog -<br>No backwards jog<br>Backwards jog  | 399 | U16    | 0      | 1                  |                  |                  |            | R/W<br>0<br>1            | ID<br>L<br>H | R/W<br>0<br>1  |  |
| <b>FUNCTIONS \ Multi speed fct</b>  |     |        |        |                    |                  |                  |            |                          |              |                |  |
| Enab multi spd<br>Enabled<br>Disabled   | 153 | I16    | 0      | 1                  | Disabled         | Disabled         | ✓          | R/Z<br>1<br>0            | -            | -              |  |
| Multi speed 1 [FF]  | 154 | I16    | -32768 | +32767             | 0                | 0                | ✓          | R/W                      | -            | -              |  |
| Multi speed 2 [FF]  | 155 | I16    | -32768 | +32767             | 0                | 0                | ✓          | R/W                      | -            | -              |  |
| Multi speed 3 [FF]  | 156 | I16    | -32768 | +32767             | 0                | 0                | ✓          | R/W                      | -            | -              |  |
| Multi speed 4 [FF]  | 157 | I16    | -32768 | +32767             | 0                | 0                | ✓          | R/W                      | -            | -              |  |
| Multi speed 5 [FF]  | 158 | I16    | -32768 | +32767             | 0                | 0                | ✓          | R/W                      | -            | -              |  |
| Multi speed 6 [FF]  | 159 | I16    | -32768 | +32767             | 0                | 0                | ✓          | R/W                      | -            | -              |  |
| Multi speed 7 [FF]  | 160 | I16    | -32768 | +32767             | 0                | 0                | ✓          | R/W                      | -            | -              |  |
| Speed sel 0<br>Value 2 <sup>0</sup> not selected<br>Value 2 <sup>0</sup> selected | 400 | U16    | 0      | 1                  | 0                | 0                | -          | R/W<br>0<br>1            | ID<br>L<br>H | R/W<br>0<br>1  |  |
| Speed sel 1<br>Value 2 <sup>1</sup> not selected<br>Value 2 <sup>1</sup> selected | 401 | U16    | 0      | 1                  | 0                | 0                | -          | R/W<br>0<br>1            | ID<br>L<br>H | R/W<br>0<br>1  |  |
| Speed sel 2<br>Value 2 <sup>2</sup> not selected<br>Value 2 <sup>2</sup> selected | 402 | U16    | 0      | 1                  | 0                | 0                | -          | R/W<br>0<br>1            | ID<br>L<br>H | R/W<br>0<br>1  |  |
| Multispeed sel  | 208 | U16    | 0      | 7                  | 0                | 0                | ✓          | R/W                      | ID           | R/W            |  |
| <b>FUNCTIONS \ Multi ramp fct</b>   |     |        |        |                    |                  |                  |            |                          |              |                |  |
| Enab multi rmp<br>Enabled<br>Disabled   | 243 | I16    | 0      | 1                  | Disabled         | Disabled         | ✓          | R/Z<br>1<br>0            | -            | -              |  |
| Ramp selector   | 202 | U16    | 0      | 3                  | 0                | 0                | ✓          | R/W                      | ID           | R/W            |  |
| <b>FUNCTIONS \ Multi ramp fct \ Ramp 0 \ Acceleration 0</b>                       |     |        |        |                    |                  |                  |            |                          |              |                |  |
| Acc delta speed0 [FF]   | 659 | U32    | 0      | 2 <sup>32</sup> -1 | 100              | 100              | ✓          | R/W                      | -            | -              |  |
| Acc delta time 0 [s]  | 660 | U16    | 0      | 65535              | 1                | 1                | ✓          | R/W                      | -            | -              |  |
| S acc t const 0 [ms]  | 665 | Float  | 100    | 3000               | 300              | 300              | ✓          | R/W                      | -            | -              |  |
| <b>FUNCTIONS \ Multi ramp fct \ Ramp 0 \ Deceleration 0</b>                       |     |        |        |                    |                  |                  |            |                          |              |                |  |
| Dec delta speed0 [FF]   | 661 | U32    | 0      | 2 <sup>32</sup> -1 | 100              | 100              | ✓          | R/W                      | -            | -              |  |
| Dec delta time 0 [s]  | 662 | U16    | 0      | 65535              | 1                | 1                | ✓          | R/W                      | -            | -              |  |
| S dec t const 0 [ms]  | 666 | Float  | 100    | 3000               | 300              | 300              | ✓          | R/W                      | -            | -              |  |
| <b>FUNCTIONS \ Multi ramp fct \ Ramp 1 \ Acceleration 1</b>                       |     |        |        |                    |                  |                  |            |                          |              |                |  |
| Acc delta speed1 [FF]   | 23  | U32    | 0      | 2 <sup>32</sup> -1 | 100              | 100              | ✓          | R/W                      | -            | -              |  |
| Acc delta time 1 [s]  | 24  | U16    | 0      | 65535              | 1                | 1                | ✓          | R/W                      | -            | -              |  |
| S acc t const 1 [ms]  | 667 | Float  | 100    | 3000               | 300              | 300              | ✓          | R/W                      | -            | -              |  |
| <b>FUNCTIONS \ Multi ramp fct \ Ramp 1 \ Deceleration 1</b>                       |     |        |        |                    |                  |                  |            |                          |              |                |  |
| Dec delta speed1 [FF]   | 31  | U32    | 0      | 2 <sup>32</sup> -1 | 100              | 100              | ✓          | R/W                      | -            | -              |  |
| Dec delta time 1 [s]  | 32  | U16    | 0      | 65535              | 1                | 1                | ✓          | R/W                      | -            | -              |  |
| S dec t const 1 [ms]  | 668 | Float  | 100    | 3000               | 300              | 300              | ✓          | R/W                      | -            | -              |  |

| Parameter  | No.  | Format | Value  |                    |                        |                  | Access via |                              |              |                |
|--|------|--------|--------|--------------------|------------------------|------------------|------------|------------------------------|--------------|----------------|
|  |      |        | min    | max                | Factory American       | Factory European | Keyp.      | RS485/<br>BUS/<br>Opt2-M     | Term.        | Opt2-A/<br>PDC |
| <b>FUNCTIONS \ Multi ramp fct \ Ramp 2 \ Acceleration 2</b>                                    |      |        |        |                    |                        |                  |            |                              |              |                |
| Acc delta speed2 [FF]  | 25   | U32    | 0      | 2 <sup>32</sup> -1 | 100                    | 100              | ✓          | R/W                          | -            | -              |
| Acc delta time 2 [s]   | 26   | U16    | 0      | 65535              | 1                      | 1                | ✓          | R/W                          | -            | -              |
| S acc t const 2 [ms]   | 669  | Float  | 100    | 3000               | 300                    | 300              | ✓          | R/W                          | -            | -              |
| <b>FUNCTIONS \ Multi ramp fct \ Ramp 2 \ Deceleration 2</b>                                    |      |        |        |                    |                        |                  |            |                              |              |                |
| Dec delta speed2 [FF]  | 33   | U32    | 0      | 2 <sup>32</sup> -1 | 100                    | 100              | ✓          | R/W                          | -            | -              |
| Dec delta time 2 [s]   | 34   | U16    | 0      | 65535              | 1                      | 1                | ✓          | R/W                          | -            | -              |
| S dec t const 2 [ms]   | 670  | Float  | 100    | 3000               | 300                    | 300              | ✓          | R/W                          | -            | -              |
| <b>FUNCTIONS \ Multi ramp fct \ Ramp 3 \ Acceleration 3</b>                                    |      |        |        |                    |                        |                  |            |                              |              |                |
| Acc delta speed3 [FF]  | 27   | U32    | 0      | 2 <sup>32</sup> -1 | 100                    | 100              | ✓          | R/W                          | -            | -              |
| Acc delta time 3 [s]   | 28   | U16    | 0      | 65535              | 1                      | 1                | ✓          | R/W                          | -            | -              |
| S acc t const 3 [ms]   | 671  | Float  | 100    | 3000               | 300                    | 300              | ✓          | R/W                          | -            | -              |
| <b>FUNCTIONS \ Multi ramp fct \ Ramp 3 \ Deceleration 3</b>                                    |      |        |        |                    |                        |                  |            |                              |              |                |
| Dec delta speed3 [FF]  | 35   | U32    | 0      | 2 <sup>32</sup> -1 | 100                    | 100              | ✓          | R/W                          | -            | -              |
| Dec delta time 3 [s]   | 36   | U16    | 0      | 65535              | 1                      | 1                | ✓          | R/W                          | -            | -              |
| S dec t const 3 [ms]   | 672  | Float  | 100    | 3000               | 300                    | 300              | ✓          | R/W                          | -            | -              |
| Ramp sel 0<br>Value 2 <sup>0</sup> not selected<br>Value 2 <sup>0</sup> selected               | 403  | U16    | 0      | 1                  | 0                      | 0                | -          | R/W<br>0<br>1                | ID<br>L<br>H | R/W<br>0<br>1  |
| Ramp sel 1<br>Value 2 <sup>1</sup> not selected<br>Value 2 <sup>1</sup> selected               | 404  | U16    | 0      | 1                  | 0                      | 0                | -          | R/W<br>0<br>1                | ID<br>L<br>H | R/W<br>0<br>1  |
| <b>FUNCTIONS \ Speed draw</b>  |      |        |        |                    |                        |                  |            |                              |              |                |
| Speed ratio  | 1017 | I16    | 0      | +32767             | +10000                 | +10000           | ✓          | R/W                          | IA           | R/W            |
| Speed draw out (d)   | 1018 | I16    | -32768 | +32767             | -                      | -                | ✓          | R                            | QA           | R/W            |
| Speed draw out (%)   | 1019 | Float  | -200.0 | +200.0             | -                      | -                | ✓          | R                            | -            | -              |
| <b>FUNCTIONS \ Overload contr</b>  |      |        |        |                    |                        |                  |            |                              |              |                |
| Enable overload<br>Enabled<br>Disabled   | 309  | I16    | 0      | 1                  | Enabled                | Disabled         | ✓          | R/Z<br>1<br>0                | -            | -              |
| Overload mode<br>Curr limited<br>Curr not limited<br>I2t Motor<br>I2t Drive<br>I2t Motor & Drv | 318  | U16    | 0      | 4                  | I <sup>2</sup> t Motor | Curr limited     | ✓          | R/W<br>0<br>1<br>2<br>3<br>4 | -            | -              |
| Overload current [%]   | 312  | U16    | P313   | 200                | 150                    | 100              | ✓          | R/W                          | -            | -              |
| Base current [%]   | 313  | U16    | 0      | P312<br>< 100      | 100                    | 80               | ✓          | R/W                          | -            | -              |
| Overload time [s]  | 310  | U16    | 0      | 65535              | 60                     | 30               | ✓          | R/W                          | -            | -              |
| Motor ovrl d preal.  | 1289 | U16    | 0      | 1                  | -                      | -                | ✓          | R                            | -            | -              |
| Motor I2t accum  | 655  | Float  | 0,00   | 100,00             | -                      | -                | ✓          | R                            | -            | -              |
| Drive ovrl d preal.  | 1438 | U16    | 0      | 1                  | -                      | -                | ✓          | R                            | -            | -              |
| Drive I2t accum  | 1439 | FLOAT  | 0,00   | 100,00             | -                      | -                | ✓          | R                            | -            | -              |
| Pause time [s]   | 311  | U16    | 0      | 65535              | 540                    | 300              | ✓          | R/W                          | -            | -              |
| Overld available<br>Overload not possible<br>Overload possible                                 | 406  | U16    | 0      | 1                  | -                      | -                | -          | R<br>0<br>1                  | QD<br>L<br>H | R<br>0<br>1    |
| Overload state<br>Current limit value<br>Current > limit value                                 | 407  | U16    | 0      | 1                  | -                      | -                | -          | R<br>0<br>1                  | QD<br>L<br>H | R<br>0<br>1    |

| Parameter   | No.  | Format | Value   |         |                   |                   | Access via |                              |       |                |
|---|------|--------|---------|---------|-------------------|-------------------|------------|------------------------------|-------|----------------|
|   |      |        | min     | max     | Factory American  | Factory European  | Keyp.      | RS485/<br>BUS/<br>Opt2-M     | Term. | Opt2-A/<br>PDC |
| <b>FUNCTIONS \ Stop control</b>   |      |        |         |         |                   |                   |            |                              |       |                |
| Stop mode<br>OFF<br>Stop & speed 0<br>Fast stp & spd 0<br>Fst / stp & spd 0             | 626  | U16    | 0       | 3       | Stop &<br>Speed 0 | Stop &<br>Speed 0 | ✓          | R/Z<br>0<br>1<br>2<br>3      | -     | -              |
| Spd 0 trip delay [ms]   | 627  | U16    | 0       | 40000   | 0                 | 0                 | ✓          | R/W                          | -     | -              |
| Trip cont delay [ms]  | 628  | U16    | 0       | 40000   | 0                 | 0                 | ✓          | R/W                          | -     | -              |
| Jog stop control<br>OFF<br>ON   | 630  | U16    | 0       | 1       | OFF               | OFF               | ✓          | R/Z<br>0<br>1                | -     | -              |
| <b>FUNCTIONS \ Brake control</b>  |      |        |         |         |                   |                   |            |                              |       |                |
| Enable Torque pr  | 1295 | I16    | 0       | 1       | Disabled          | Disabled          | ✓          | R/W                          | -     | -              |
| Closing speed [rpm]   | 1262 | U16    | 0       | 200     | 30                | 30                | ✓          | R/W                          | -     | -              |
| Torque delay [ms]   | 1293 | I16    | 0       | 30000   | 3000              | 3000              | ✓          | R/W                          | -     | -              |
| Torque proving [%]  | 1294 | I16    | 0       | 200     | 75                | 75                | ✓          | R/W                          | -     | -              |
| Actuator delay [ms]   | 1266 | U16    | 0       | 30000   | 1000              | 1000              | ✓          | R/W                          | -     | -              |
| <b>FUNCTIONS \ I/n curve (Taper curr lim)</b>   |      |        |         |         |                   |                   |            |                              |       |                |
| I/n curve<br>Enabled<br>Disabled  | 750  | U16    | 0       | 1       | 0                 | 0                 | ✓          | R/Z<br>1<br>0                | -     | -              |
| I/n lim 0 [%]   | 751  | U16    | 0       | 200     | 0                 | 0                 | ✓          | R/Z                          | -     | -              |
| I/n lim 1 [%]   | 752  | U16    | 0       | 200     | 0                 | 0                 | ✓          | R/Z                          | -     | -              |
| I/n lim 2 [%]   | 753  | U16    | 0       | 200     | 0                 | 0                 | ✓          | R/Z                          | -     | -              |
| I/n lim 3 [%]   | 754  | U16    | 0       | 200     | 0                 | 0                 | ✓          | R/Z                          | -     | -              |
| I/n lim 4 [%]   | 755  | U16    | 0       | 200     | 0                 | 0                 | ✓          | R/Z                          | -     | -              |
| I/n speed [rpm]   | 756  | U16    | 0       | P162    | 0                 | 0                 | ✓          | R/Z                          | -     | -              |
| <b>SPEC FUNCTIONS \ Test generator</b>  |      |        |         |         |                   |                   |            |                              |       |                |
| Generator access<br>Not connected<br>T current ref<br>Flux ref<br>Ramp ref<br>Speed ref | 58   | U16    | 0       | 5       | Not conn.         | Not conn.         | ✓          | R/Z<br>0<br>2<br>3<br>4<br>5 | -     | -              |
| Gen frequency [Hz]  | 59   | Float  | 0.1     | 62.5    | 0.1               | 0.1               | ✓          | R/W                          | -     | -              |
| Gen amplitude [%]   | 60   | Float  | 0       | 200.00  | 0                 | 0                 | ✓          | R/W                          | -     | -              |
| Generator offset [%]  | 61   | Float  | -200.00 | +200.00 | 0                 | 0                 | ✓          | R/W                          | -     | -              |

| Parameter                              | No. | Format | Value            |                    |                  |                  | Access via |                          |        |                |
|--|-----|--------|------------------|--------------------|------------------|------------------|------------|--------------------------|--------|----------------|
|  |     |        | min              | max                | Factory American | Factory European | Keyp.      | RS485/<br>BUS/<br>Opt2-M | Term.  | Opt2-A/<br>PDC |
| <b>SPEC FUNCTIONS</b>                  |     |        |                  |                    |                  |                  |            |                          |        |                |
| Save parameters                        | 256 | U16    |                  |                    |                  |                  | ✓          | C/W(1)                   | -      | -              |
| Load default                           | 258 | U16    |                  |                    |                  |                  | ✓          | Z/C(1)                   | -      | -              |
| Life time [h.min]                      | 235 | Float  | 0.00             | 65535.00           |                  |                  | ✓          | R                        | -      | -              |
| Failure register                       | 330 | U16    | 1                | 10                 | 10               | 10               | ✓          | R/W                      | -      | -              |
| Failure text                           | 327 | Text   |                  |                    |                  |                  | -          | R                        | -      | -              |
| Failure hour                           | 328 | U16    | 0                | 65535              |                  |                  |            | R                        | -      | -              |
| Failure minute                         | 329 | U16    | 0                | 59                 |                  |                  |            | R                        | -      | -              |
| Failure code                           | 417 | U16    | 0                | 65535              |                  |                  |            | R                        | -      | -              |
| Failure supply                         |     |        |                  |                    |                  |                  |            | 5100h                    |        |                |
| Undervoltage                           |     |        |                  |                    |                  |                  |            | 3120h                    |        |                |
| Overvoltage                            |     |        |                  |                    |                  |                  |            | 3310h                    |        |                |
| Overcurrent                            |     |        |                  |                    |                  |                  |            | 2300h                    |        |                |
| Heatsink                               |     |        |                  |                    |                  |                  |            | 4210h                    |        |                |
| Hardware                               |     |        |                  |                    |                  |                  |            | 5000h                    |        |                |
| DSP error                              |     |        |                  |                    |                  |                  |            | 6110h                    |        |                |
| Interrupt error                        |     |        |                  |                    |                  |                  |            | 6120h                    |        |                |
| Speed fbk                              |     |        |                  |                    |                  |                  |            | 7301h                    |        |                |
| External fault                         |     |        |                  |                    |                  |                  |            | 9000h                    |        |                |
| Overtemp motor                         |     |        |                  |                    |                  |                  |            | 4310h                    |        |                |
| Field loss                             |     |        |                  |                    |                  |                  |            | 3330h                    |        |                |
| Bus loss                               |     |        |                  |                    |                  |                  |            | 8110h                    |        |                |
| Hw opt 1 failure                       |     |        |                  |                    |                  |                  |            | 7510h                    |        |                |
| Opt2                                   |     |        |                  |                    |                  |                  |            | 7400h                    |        |                |
| Unknown                                |     |        |                  |                    |                  |                  |            | 1001h                    |        |                |
| Enable seq err                         |     |        |                  |                    |                  |                  |            | 9009h                    |        |                |
| Failure reset                          | 262 | U16    |                  |                    |                  |                  | ✓          | Z/C (1)                  | ID (H) | W              |
| Failure reg del                        | 263 | U16    |                  |                    |                  |                  | ✓          | C                        | -      | -              |
| <b>SPEC FUNCTIONS \ Links \ Link 1</b> |     |        |                  |                    |                  |                  |            |                          |        |                |
| Source                                 | 484 | U16    | 0                | 65535              | 0                | 0                | ✓          | R/W                      | -      | -              |
| Destination                            | 485 | U16    | 0                | 65535              | 0                | 0                | ✓          | R/W                      | -      | -              |
| Mul gain                               | 486 | Float  | -10000           | +10000             | 1                | 1                | ✓          | R/W                      | -      | -              |
| Div gain                               | 487 | Float  | -10000           | +10000             | 1                | 1                | ✓          | R/W                      | -      | -              |
| Input max                              | 488 | Float  | -2 <sup>31</sup> | 2 <sup>31</sup> -1 | 0                | 0                | ✓          | R/W                      | -      | -              |
| Input min                              | 489 | Float  | -2 <sup>31</sup> | 2 <sup>31</sup> -1 | 0                | 0                | ✓          | R/W                      | -      | -              |
| Input offset                           | 490 | Float  | -2 <sup>31</sup> | 2 <sup>31</sup> -1 | 0                | 0                | ✓          | R/W                      | -      | -              |
| Output offset                          | 491 | Float  | -2 <sup>31</sup> | 2 <sup>31</sup> -1 | 0                | 0                | ✓          | R/W                      | -      | -              |
| Inp absolute                           | 492 | U16    | 0                | 1                  | OFF              | OFF              | ✓          | R/W                      | -      | -              |
| OFF                                    |     |        |                  |                    |                  |                  |            | 0                        |        |                |
| ON                                     |     |        |                  |                    |                  |                  |            | 1                        |        |                |
| <b>SPEC FUNCTIONS \ Links \ Link 2</b> |     |        |                  |                    |                  |                  |            |                          |        |                |
| Source                                 | 553 | U16    | 0                | 65535              | 0                | 0                | ✓          | R/W                      | -      | -              |
| Destination                            | 554 | U16    | 0                | 65535              | 0                | 0                | ✓          | R/W                      | -      | -              |
| Mul gain                               | 555 | Float  | -10000           | +10000             | 1                | 1                | ✓          | R/W                      | -      | -              |
| Div gain                               | 556 | Float  | -10000           | +10000             | 1                | 1                | ✓          | R/W                      | -      | -              |
| Input max                              | 557 | Float  | -2 <sup>31</sup> | 2 <sup>31</sup> -1 | 0                | 0                | ✓          | R/W                      | -      | -              |
| Input min                              | 558 | Float  | -2 <sup>31</sup> | 2 <sup>31</sup> -1 | 0                | 0                | ✓          | R/W                      | -      | -              |
| Input offset                           | 559 | Float  | -2 <sup>31</sup> | 2 <sup>31</sup> -1 | 0                | 0                | ✓          | R/W                      | -      | -              |
| Output offset                          | 560 | Float  | -2 <sup>31</sup> | 2 <sup>31</sup> -1 | 0                | 0                | ✓          | R/W                      | -      | -              |
| Inp absolute                           | 561 | U16    | 0                | 1                  | OFF              | OFF              | ✓          | R/W                      | -      | -              |
| OFF                                    |     |        |                  |                    |                  |                  |            | 0                        |        |                |
| ON                                     |     |        |                  |                    |                  |                  |            | 1                        |        |                |

| Parameter                              | No.  | Format | Value            |                    |                  |                  | Access via |                          |       |                |
|--|------|--------|------------------|--------------------|------------------|------------------|------------|--------------------------|-------|----------------|
|  |      |        | min              | max                | Factory American | Factory European | Keyp.      | RS485/<br>BUS/<br>Opt2-M | Term. | Opt2-A/<br>PDC |
| <b>SPEC FUNCTIONS \ Links \ Link 3</b> |      |        |                  |                    |                  |                  |            |                          |       |                |
| Source                                 | 1218 | U16    | 0                | 65535              | 0                | 0                | ✓          | R/W                      | -     | -              |
| Destination                            | 1219 | U16    | 0                | 65535              | 0                | 0                | ✓          | R/W                      | -     | -              |
| Mul gain                               | 1220 | Float  | -10000           | +10000             | 1                | 1                | ✓          | R/W                      | -     | -              |
| Div gain                               | 1221 | Float  | -10000           | +10000             | 1                | 1                | ✓          | R/W                      | -     | -              |
| Input max                              | 1222 | Float  | -2 <sup>31</sup> | 2 <sup>31</sup> -1 | 0                | 0                | ✓          | R/W                      | -     | -              |
| Input min                              | 1223 | Float  | -2 <sup>31</sup> | 2 <sup>31</sup> -1 | 0                | 0                | ✓          | R/W                      | -     | -              |
| Input offset                           | 1224 | Float  | -2 <sup>31</sup> | 2 <sup>31</sup> -1 | 0                | 0                | ✓          | R/W                      | -     | -              |
| Output offset                          | 1225 | Float  | -2 <sup>31</sup> | 2 <sup>31</sup> -1 | 0                | 0                | ✓          | R/W                      | -     | -              |
| Inp absolute                           | 1226 | U16    | 0                | 1                  | OFF<br>0         | OFF<br>0         | ✓          | R/W                      | -     | -              |
| ON<br>OFF                              |      |        |                  |                    |                  |                  |            | 1<br>0                   |       |                |
| <b>SPEC FUNCTIONS \ Links \ Link 4</b> |      |        |                  |                    |                  |                  |            |                          |       |                |
| Source                                 | 1227 | U16    | 0                | 65535              | 0                | 0                | ✓          | R/W                      | -     | -              |
| Destination                            | 1228 | U16    | 0                | 65535              | 0                | 0                | ✓          | R/W                      | -     | -              |
| Mul gain                               | 1229 | Float  | -10000           | +10000             | 1                | 1                | ✓          | R/W                      | -     | -              |
| Div gain                               | 1230 | Float  | -10000           | +10000             | 1                | 1                | ✓          | R/W                      | -     | -              |
| Input max                              | 1231 | Float  | -2 <sup>31</sup> | 2 <sup>31</sup> -1 | 0                | 0                | ✓          | R/W                      | -     | -              |
| Input min                              | 1232 | Float  | -2 <sup>31</sup> | 2 <sup>31</sup> -1 | 0                | 0                | ✓          | R/W                      | -     | -              |
| Input offset                           | 1233 | Float  | -2 <sup>31</sup> | 2 <sup>31</sup> -1 | 0                | 0                | ✓          | R/W                      | -     | -              |
| Output offset                          | 1234 | Float  | -2 <sup>31</sup> | 2 <sup>31</sup> -1 | 0                | 0                | ✓          | R/W                      | -     | -              |
| Inp absolute                           | 1235 | U16    | 0                | 1                  | OFF<br>0         | OFF<br>0         | ✓          | R/W                      | -     | -              |
| ON<br>OFF                              |      |        |                  |                    |                  |                  |            | 1<br>0                   |       |                |
| <b>SPEC FUNCTIONS \ Links \ Link 5</b> |      |        |                  |                    |                  |                  |            |                          |       |                |
| Source                                 | 1236 | U16    | 0                | 65535              | 0                | 0                | ✓          | R/W                      | -     | -              |
| Destination                            | 1237 | U16    | 0                | 65535              | 0                | 0                | ✓          | R/W                      | -     | -              |
| Mul gain                               | 1238 | Float  | -10000           | +10000             | 1                | 1                | ✓          | R/W                      | -     | -              |
| Div gain                               | 1239 | Float  | -10000           | +10000             | 1                | 1                | ✓          | R/W                      | -     | -              |
| Input max                              | 1240 | Float  | -2 <sup>31</sup> | 2 <sup>31</sup> -1 | 0                | 0                | ✓          | R/W                      | -     | -              |
| Input min                              | 1241 | Float  | -2 <sup>31</sup> | 2 <sup>31</sup> -1 | 0                | 0                | ✓          | R/W                      | -     | -              |
| Input offset                           | 1242 | Float  | -2 <sup>31</sup> | 2 <sup>31</sup> -1 | 0                | 0                | ✓          | R/W                      | -     | -              |
| Output offset                          | 1243 | Float  | -2 <sup>31</sup> | 2 <sup>31</sup> -1 | 0                | 0                | ✓          | R/W                      | -     | -              |
| Inp absolute                           | 1244 | U16    | 0                | 1                  | OFF<br>0         | OFF<br>0         | ✓          | R/W                      | -     | -              |
| ON<br>OFF                              |      |        |                  |                    |                  |                  |            | 1<br>0                   |       |                |
| <b>SPEC FUNCTIONS \ Links \ Link 6</b> |      |        |                  |                    |                  |                  |            |                          |       |                |
| Source                                 | 1245 | U16    | 0                | 65535              | 0                | 0                | ✓          | R/W                      | -     | -              |
| Destination                            | 1246 | U16    | 0                | 65535              | 0                | 0                | ✓          | R/W                      | -     | -              |
| Mul gain                               | 1247 | Float  | -10000           | +10000             | 1                | 1                | ✓          | R/W                      | -     | -              |
| Div gain                               | 1248 | Float  | -10000           | +10000             | 1                | 1                | ✓          | R/W                      | -     | -              |
| Input max                              | 1249 | Float  | -2 <sup>31</sup> | 2 <sup>31</sup> -1 | 0                | 0                | ✓          | R/W                      | -     | -              |
| Input min                              | 1250 | Float  | -2 <sup>31</sup> | 2 <sup>31</sup> -1 | 0                | 0                | ✓          | R/W                      | -     | -              |
| Input offset                           | 1251 | Float  | -2 <sup>31</sup> | 2 <sup>31</sup> -1 | 0                | 0                | ✓          | R/W                      | -     | -              |
| Output offset                          | 1252 | Float  | -2 <sup>31</sup> | 2 <sup>31</sup> -1 | 0                | 0                | ✓          | R/W                      | -     | -              |
| Inp absolute                           | 1253 | U16    | 0                | 1                  | OFF<br>0         | OFF<br>0         | ✓          | R/W                      | -     | -              |
| ON<br>OFF                              |      |        |                  |                    |                  |                  |            | 1<br>0                   |       |                |

| Parameter                              | No. | Format | Value  |        |                  |                  | Keypr. | Access via               |          |                |
|--|-----|--------|--------|--------|------------------|------------------|--------|--------------------------|----------|----------------|
|  |     |        | min    | max    | Factory American | Factory European |        | RS485/<br>BUS/<br>Opt2-M | Term.    | Opt2-A/<br>PDC |
| <b>SPEC FUNCTIONS \ Pad Parameters</b> |     |        |        |        |                  |                  |        |                          |          |                |
| Pad 0                                  | 503 | I16    | -32768 | +32767 | 0                | 0                | ✓      | R/W                      | IA, QA   | R/W            |
| Pad 1                                  | 504 | I16    | -32768 | +32767 | 0                | 0                | ✓      | R/W                      | IA, QA   | R/W            |
| Pad 2                                  | 505 | I16    | -32768 | +32767 | 0                | 0                | ✓      | R/W                      | IA       | R/W            |
| Pad 3                                  | 506 | I16    | -32768 | +32767 | 0                | 0                | ✓      | R/W                      | IA       | R/W            |
| Pad 4                                  | 507 | I16    | -32768 | +32767 | 0                | 0                | ✓      | R/W                      | QA       | R/W            |
| Pad 5                                  | 508 | I16    | -32768 | +32767 | 0                | 0                | ✓      | R/W                      | QA       | R/W            |
| Pad 6                                  | 509 | I16    | -32768 | +32767 | 0                | 0                | ✓      | R/W                      | QA       | R/W            |
| Pad 7                                  | 510 | I16    | -32768 | +32767 | 0                | 0                | ✓      | R/W                      | -        | R/W            |
| Pad 8                                  | 511 | I16    | -32768 | +32767 | 0                | 0                | ✓      | R/W                      | -        | R/W            |
| Pad 9                                  | 512 | I16    | -32768 | +32767 | 0                | 0                | ✓      | R/W                      | -        | R/W            |
| Pad 10                                 | 513 | I16    | -32768 | +32767 | 0                | 0                | ✓      | R/W                      | -        | R/W            |
| Pad 11                                 | 514 | I16    | -32768 | +32767 | 0                | 0                | ✓      | R/W                      | -        | R/W            |
| Pad 12                                 | 515 | I16    | -32768 | +32767 | 0                | 0                | ✓      | R/W                      | -        | R/W            |
| Pad 13                                 | 516 | I16    | -32768 | +32767 | 0                | 0                | ✓      | R/W                      | -        | R/W            |
| Pad 14                                 | 517 | I16    | -32768 | +32767 | 0                | 0                | ✓      | R/W                      | -        | R/W            |
| Pad 15                                 | 518 | I16    | -32768 | +32767 | 0                | 0                | ✓      | R/W                      | -        | R/W            |
| Bitword pad A                          | 519 | U16    | 0      | 65535  | 0                | 0                | ✓      | R/W                      | ID*, QD* | R/W            |
| Pad A Bit 0                            | 520 | U16    | 0      | 1      | 0                | 0                | -      | R/W                      | ID, QD   | R/W            |
| Pad A Bit 1                            | 521 | U16    | 0      | 1      | 0                | 0                | -      | R/W                      | ID, QD   | R/W            |
| Pad A Bit 2                            | 522 | U16    | 0      | 1      | 0                | 0                | -      | R/W                      | ID, QD   | R/W            |
| Pad A Bit 3                            | 523 | U16    | 0      | 1      | 0                | 0                | -      | R/W                      | ID, QD   | R/W            |
| Pad A Bit 4                            | 524 | U16    | 0      | 1      | 0                | 0                | -      | R/W                      | ID, QD   | R/W            |
| Pad A Bit 5                            | 525 | U16    | 0      | 1      | 0                | 0                | -      | R/W                      | ID, QD   | R/W            |
| Pad A Bit 6                            | 526 | U16    | 0      | 1      | 0                | 0                | -      | R/W                      | ID, QD   | R/W            |
| Pad A Bit 7                            | 527 | U16    | 0      | 1      | 0                | 0                | -      | R/W                      | ID, QD   | R/W            |
| Pad A Bit 8                            | 528 | U16    | 0      | 1      | 0                | 0                | -      | R/W                      | QD*      | -              |
| Pad A Bit 9                            | 529 | U16    | 0      | 1      | 0                | 0                | -      | R/W                      | QD*      | -              |
| Pad A Bit 10                           | 530 | U16    | 0      | 1      | 0                | 0                | -      | R/W                      | QD*      | -              |
| Pad A Bit 11                           | 531 | U16    | 0      | 1      | 0                | 0                | -      | R/W                      | QD*      | -              |
| Pad A Bit 12                           | 532 | U16    | 0      | 1      | 0                | 0                | -      | R/W                      | QD*      | -              |
| Pad A Bit 13                           | 533 | U16    | 0      | 1      | 0                | 0                | -      | R/W                      | QD*      | -              |
| Pad A Bit 14                           | 534 | U16    | 0      | 1      | 0                | 0                | -      | R/W                      | QD*      | -              |
| Pad A Bit 15                           | 535 | U16    | 0      | 1      | 0                | 0                | -      | R/W                      | QD*      | -              |
| Bitword pad B                          | 536 | U16    | 0      | 65535  | 0                | 0                | ✓      | R/W                      | QD*      | R/W            |
| Pad B Bit 0                            | 537 | U16    | 0      | 1      | 0                | 0                | -      | R/W                      | QD       | R              |
| Pad B Bit 1                            | 538 | U16    | 0      | 1      | 0                | 0                | -      | R/W                      | QD       | R              |
| Pad B Bit 2                            | 539 | U16    | 0      | 1      | 0                | 0                | -      | R/W                      | QD       | R              |
| Pad B Bit 3                            | 540 | U16    | 0      | 1      | 0                | 0                | -      | R/W                      | QD       | R              |
| Pad B Bit 4                            | 541 | U16    | 0      | 1      | 0                | 0                | -      | R/W                      | QD       | R              |
| Pad B Bit 5                            | 542 | U16    | 0      | 1      | 0                | 0                | -      | R/W                      | QD       | R              |
| Pad B Bit 6                            | 543 | U16    | 0      | 1      | 0                | 0                | -      | R/W                      | QD       | R              |
| Pad B Bit 7                            | 544 | U16    | 0      | 1      | 0                | 0                | -      | R/W                      | QD       | R              |
| Pad B Bit 8                            | 545 | U16    | 0      | 1      | 0                | 0                | -      | R/W                      | QD*      | -              |
| Pad B Bit 9                            | 546 | U16    | 0      | 1      | 0                | 0                | -      | R/W                      | QD*      | -              |
| Pad B Bit 10                           | 547 | U16    | 0      | 1      | 0                | 0                | -      | R/W                      | QD*      | -              |
| Pad B Bit 11                           | 548 | U16    | 0      | 1      | 0                | 0                | -      | R/W                      | QD*      | -              |
| Pad B Bit 12                           | 549 | U16    | 0      | 1      | 0                | 0                | -      | R/W                      | QD*      | -              |
| Pad B Bit 13                           | 550 | U16    | 0      | 1      | 0                | 0                | -      | R/W                      | QD*      | -              |
| Pad B Bit 14                           | 551 | U16    | 0      | 1      | 0                | 0                | -      | R/W                      | QD*      | -              |
| Pad B Bit 15                           | 552 | U16    | 0      | 1      | 0                | 0                | -      | R/W                      | QD*      | -              |



| Parameter  | No.  | Format | Value              |                           |                  |                  | Access via |                          |       |                |  |
|--|------|--------|--------------------|---------------------------|------------------|------------------|------------|--------------------------|-------|----------------|--|
|  |      |        | min                | max                       | Factory American | Factory European | Keyp.      | RS485/<br>BUS/<br>Opt2-M | Term. | Opt2-A/<br>PDC |  |
| <b>OPTIONS \ Option 1</b>  |      |        |                    |                           |                  |                  |            |                          |       |                |  |
| Accessible only with optional Field Bus card (see Bus card user manual)      |      |        |                    |                           |                  |                  |            |                          |       |                |  |
| <b>OPTIONS \ Option 2</b>  |      |        |                    |                           |                  |                  |            |                          |       |                |  |
| Menu Accessible only with optional APC200 card (see APC200 card user manual) |      |        |                    |                           |                  |                  |            |                          |       |                |  |
| Enable OPT2  | 425  | U16    | 0                  | 1                         | Disable          | Disable          | ✓          | R/Z<br>1<br>0            | -     | -              |  |
| Enabled  |      |        |                    |                           |                  |                  |            |                          |       |                |  |
| Disabled   |      |        |                    |                           |                  |                  |            |                          |       |                |  |
| <b>OPTIONS \ PID</b>   |      |        |                    |                           |                  |                  |            |                          |       |                |  |
| Enable PI PID  | 769  | U16    | 0                  | 1                         | Disable          | Disable          | ✓          | R/W<br>1<br>0            | ID    | R/W            |  |
| Enabled  |      |        |                    |                           |                  |                  |            |                          |       |                |  |
| Disabled   |      |        |                    |                           |                  |                  |            |                          |       |                |  |
| Enable PD PID  | 770  | U16    | 0                  | 1                         | Disable          | Disable          | ✓          | R/W<br>1<br>0            | ID    | R/W            |  |
| Enabled  |      |        |                    |                           |                  |                  |            |                          |       |                |  |
| Disabled   |      |        |                    |                           |                  |                  |            |                          |       |                |  |
| Enable PI-PD PID   | 1258 | U16    | 0                  | 1                         | Disabled<br>0    | Disabled<br>0    | -          | R/W<br>1<br>0            | ID    | R/W            |  |
| Enabled  |      |        |                    |                           |                  |                  |            |                          |       |                |  |
| Disabled   |      |        |                    |                           |                  |                  |            |                          |       |                |  |
| <b>OPTIONS \ PID \ PID source</b>  |      |        |                    |                           |                  |                  |            |                          |       |                |  |
| PID source   | 786  | U16    | 0                  | 65535                     | 0                | 0                | ✓          | R/W                      | -     | -              |  |
| PID source gain  | 787  | Float  | -100.000           | +100.00                   | 1.000            | 1.000            | ✓          | R/W                      | -     | -              |  |
| Feed-fwd PID   | 758  | I16    | -10000             | +10000                    | 0                | 0                | ✓          | R                        | IA    | R              |  |
| <b>OPTIONS \ PID \ PID references</b>  |      |        |                    |                           |                  |                  |            |                          |       |                |  |
| PID error  | 759  | I16    | -10000             | +10000                    | 0                | 0                | ✓          | R                        | -     | R              |  |
| PID feed-back  | 763  | I16    | -10000             | +10000                    | 0                | 0                | ✓          | R/W                      | IA    | R/W            |  |
| PID offs. Sel  | 762  | U16    | 0                  | 1                         | 0                | 0                | ✓          | R/W<br>0<br>1            | ID    | R/W            |  |
| Offset 0   |      |        |                    |                           |                  |                  |            |                          |       |                |  |
| Offset 1   |      |        |                    |                           |                  |                  |            |                          |       |                |  |
| PID offset 0   | 760  | I16    | -10000             | +10000                    | 0                | 0                | ✓          | R/W                      | IA    | R/W            |  |
| PID offset 1   | 761  | I16    | -10000             | +10000                    | 0                | 0                | ✓          | R/W                      | -     | -              |  |
| PID acc time   | 1046 | Float  | 0.0                | 900.0                     | 0.0              | 0.0              | ✓          | R/W                      | -     | -              |  |
| PID dec time   | 1047 | Float  | 0.0                | 900.0                     | 0.0              | 0.0              | ✓          | R/W                      | -     | -              |  |
| PID clamp  | 757  | I16    | -10000             | +10000                    | 10000            | 10000            | ✓          | R/W                      | -     | -              |  |
| <b>OPTIONS \ PID \ PI controls</b>   |      |        |                    |                           |                  |                  |            |                          |       |                |  |
| PI P gain PID  | 765  | Float  | 0.00               | 100.00                    | 10.00            | 10.00            | ✓          | R/W                      | -     | -              |  |
| PI I gain PID  | 764  | Float  | 0.00               | 100.00                    | 10.00            | 10.00            | ✓          | R/W                      | -     | -              |  |
| PI steady thr  | 695  | I16    | 0                  | 10000                     | 0                | 0                | ✓          | R/W                      | -     | -              |  |
| PI steady delay  | 731  | U16    | 0                  | 60000                     | 0                | 0                | ✓          | R/W                      | -     | -              |  |
| P init gain PID  | 793  | Float  | 0.00               | 100.00                    | 10.00            | 10.00            | ✓          | R/W                      | -     | -              |  |
| I init gain PID  | 734  | Float  | 0.00               | 100.00                    | 10.00            | 10.00            | ✓          | R/W                      | -     | -              |  |
| PI central v sel   | 779  | U16    | 0                  | 3                         | 1                | 1                | ✓          | R/W                      | ID    | R/W            |  |
| PI central v1  | 776  | Float  | PI bot-<br>tom lim | PI top<br>lim             | 1.00             | 1.00             | ✓          | R/W                      | -     | -              |  |
| PI central v2  | 777  | Float  | PI bot-<br>tom lim | PI top<br>Lim             | 1.00             | 1.00             | ✓          | R/W                      | -     | -              |  |
| PI central v3  | 778  | Float  | PI bot-<br>tom lim | PI top<br>Lim             | 1.00             | 1.00             | ✓          | R/W                      | IA    | -              |  |
| PI top lim   | 784  | Float  | PI bot-<br>tom lim | 10.00                     | 10.00            | 10.00            | ✓          | R/W                      | -     | -              |  |
| PI bottom lim  | 785  | Float  | -10.00             | PI top lim                | 0.0              | 0.0              | ✓          | R/W                      | -     | -              |  |
| PI integr freeze   | 783  | U16    | 0                  | 1                         | 0                | 0                | ✓          | R/W<br>0<br>1            | ID    | R/W            |  |
| OFF  |      |        |                    |                           |                  |                  |            |                          |       |                |  |
| ON   |      |        |                    |                           |                  |                  |            |                          |       |                |  |
| PI output PID  | 771  | I16    | 0                  | 1000 x<br>PI top<br>limit | 1000             | 1000             | ✓          | R                        | -     | R              |  |
| Real FF PID  | 418  | I16    | -10000             | +10000                    | 0                | 0                | ✓          | R/W                      | -     | R              |  |



| Parameter  | No.  | Format | Value    |          |                  |                  | Access via |                          |       |                |
|--|------|--------|----------|----------|------------------|------------------|------------|--------------------------|-------|----------------|
|  |      |        | min      | max      | Factory American | Factory European | Keyp.      | RS485/<br>BUS/<br>Opt2-M | Term. | Opt2-A/<br>PDC |
| <b>OPTIONS \ PID \ PD control</b>                |      |        |          |          |                  |                  |            |                          |       |                |
| PD P gain 1 PID [%]                              | 768  | Float  | 0.00     | 100.00   | 10.00            | 10.00            | ✓          | R/W                      | -     | -              |
| PD D gain 1 PID [%]                              | 766  | Float  | 0.00     | 100.00   | 1.00             | 1.00             | ✓          | R/W                      | -     | -              |
| PD P gain 2 PID [%]                              | 788  | Float  | 0.00     | 100.00   | 10.00            | 10.00            | ✓          | R/W                      | -     | -              |
| PD D gain 2 PID [%]                              | 789  | Float  | 0.00     | 100.00   | 1.00             | 1.00             | ✓          | R/W                      | -     | -              |
| PD P gain 3 PID [%]                              | 790  | Float  | 0.00     | 100.00   | 10.00            | 10.00            | ✓          | R/W                      | -     | -              |
| PD D gain 3 PID [%]                              | 791  | Float  | 0.00     | 100.00   | 1.00             | 1.00             | ✓          | R/W                      | -     | -              |
| PD D filter PID [ms]                             | 767  | U16    | 0        | 1000     | 0                | 0                | ✓          | R/W                      | -     | -              |
| PD output PID                                    | 421  | I16    | -10000   | +10000   | 0                | 0                | ✓          | R                        | -     | -              |
| PID out sign PID<br>Positive<br>Bipolar          | 772  | U16    | 0        | 1        | 1                | 1                | ✓          | R/W<br>0<br>1            | -     | -              |
| PID output                                       | 774  | I16    | -10000   | +10000   | 0                | 0                | ✓          | R                        | QA    | R              |
| <b>OPTIONS \ PID \ PID target</b>                |      |        |          |          |                  |                  |            |                          |       |                |
| PID target                                       | 782  | U16    | 0        | 65535    | 0                | 0                | ✓          | R/W                      | -     | -              |
| PID out scale                                    | 773  | Float  | -100.000 | -100.000 | 1.000            | 1.000            | ✓          | R/W                      | -     | -              |
| <b>OPTIONS \ PID \ Diameter calc</b>             |      |        |          |          |                  |                  |            |                          |       |                |
| Diameter calc<br>Enabled<br>Disabled             | 794  | U16    | 0        | 1        | 0                | 0                | ✓          | Z/R<br>1<br>0            | ID    | R/W            |
| Positioning spd [rpm]                            | 795  | I16    | -100     | +100     | 0                | 0                | ✓          | R/W                      | -     | -              |
| Max deviation                                    | 796  | I16    | 0        | +10000   | 8000             | 8000             | ✓          | R/W                      | -     | -              |
| Gear box ratio                                   | 797  | Float  | 0.001    | 1.000    | 1.000            | 1.000            | ✓          | R/W                      | -     | -              |
| Dancer constant [mm]                             | 798  | U16    | 1        | 10000    | 1                | 1                | ✓          | R/W                      | -     | -              |
| Minimum diameter [cm]                            | 799  | U16    | 1        | 2000     | 1                | 1                | ✓          | R/W                      | -     | -              |
| <b>OPTIONS \ PID</b>                             |      |        |          |          |                  |                  |            |                          |       |                |
| PI central vs0                                   | 780  | U16    | 0        | 1        | 1                | 1                | -          | R/W                      | ID    | R/W            |
| PI central vs1                                   | 781  | U16    | 0        | 1        | 0                | 0                | -          | R/W                      | ID    | R/W            |
| Diameter calc st                                 | 800  | U16    | 0        | 1        | 0                | 0                | -          | R                        | QD    | R              |
| <b>OPTIONS \ TORQUE WINDER</b>                   |      |        |          |          |                  |                  |            |                          |       |                |
| Torque winder En<br>Enabled<br>Disabled          | 1209 | U16    | 0        | 1        | Disabled<br>0    | Disabled<br>0    | ✓          | R/W<br>1<br>0            | ID    | R/W            |
| <b>OPTIONS \ TORQUE WINDER \ Diam Calculatio</b> |      |        |          |          |                  |                  |            |                          |       |                |
| Roll diameter [m]                                | 1154 | Float  | 0.000    | 32.000   |                  |                  | ✓          | R                        | QA    | -              |
| Line speed [%]                                   | 1160 | Float  | 0.00     | 200.00   |                  |                  | ✓          | R                        | -     | -              |
| Ref line speed [%]                               | 1286 | Float  | 0.00     | 200.00   |                  |                  | ✓          | R                        | -     | -              |
| Diam calc Dis<br>ON<br>OFF                       | 1161 | U16    | 0        | 1        | ON<br>(1)        | ON<br>(1)        | ✓          | R/W<br>1<br>0            | ID    | R/W            |
| Diam inc/dec En<br>Enabled<br>Disabled           | 1205 | U16    | 0        | 1        | Enabled<br>(0)   | Enabled<br>(0)   | ✓          | R/W<br>1<br>0            | ID    | R/W            |
| Wind/unwind<br>Unwinder<br>Winder                | 1187 | U16    | 0        | 1        | Winder<br>(0)    | Winder<br>(0)    | ✓          | R/W<br>1<br>0            | ID    | R/W            |
| Minimum diameter [mm]                            | 799  | U16    | 1        | 2000     | 100              | 100              | ✓          | R/Z                      | -     | -              |
| Maximum diameter [m]                             | 1153 | Float  | 0.000    | 32.000   | 1.000            | 1.000            | ✓          | R/Z                      | -     | -              |
| Line spd source                                  | 1204 | U16    | 0        | 65535    | 0                | 0                | ✓          | R/Z                      | -     | -              |
| Ref spd source                                   | 1284 | U16    | 0        | 65535    | 0                | 0                | ✓          | R/Z                      | -     | -              |
| Line speed gain                                  | 1156 | I16    | 0        | 32767    | 0                | 0                | ✓          | R/W                      | -     | -              |
| Ref speed gain                                   | 1285 | I16    | 0        | 32767    | 0                | 0                | ✓          | R/W                      | -     | -              |
| Base omega [rpm]                                 | 1163 | U16    | 0        | 8191     | 1500             | 1500             | ✓          | R/W                      | -     | -              |
| Ref speed thr [%]                                | 1155 | Float  | 0        | 150.00   | 5                | 5                | ✓          | R/W                      | -     | -              |

| Parameter   | No.  | Format | Value   |         |                  |                  | Access via |                          |       |                |  |
|---|------|--------|---------|---------|------------------|------------------|------------|--------------------------|-------|----------------|--|
|   |      |        | min     | max     | Factory American | Factory European | Keyp.      | RS485/<br>BUS/<br>Opt2-M | Term. | Opt2-A/<br>PDC |  |
| Diam filter [ms]  | 1162 | U16    | 0       | 5000    | 100              | 100              | ✓          | R/W                      | -     | -              |  |
| Diam init filter [ms]   | 1206 | U16    | 0       | 5000    | 100              | 100              | ✓          | R/W                      | -     | -              |  |
| Diam stdy delay [ms]  | 1207 | U16    | 0       | 60000   | 0                | 0                | ✓          | R/W                      | -     | -              |  |
| Diam reset  | 1157 | U16    | 0       | 1       | 0                | 0                | ✓          | R/W                      | ID    | R/W            |  |
| Diam thr [%]  | 1158 | Float  | 0       | 150.00  | 10               | 10               | ✓          | R/W                      | -     | -              |  |
| Diam reached  | 1159 | U16    | 0       | 1       |                  |                  | ✓          | R                        | QD    | R              |  |
| Diam preset sel   | 1168 | U16    | 0       | 3       | 0                | 0                | ✓          | R/W                      | ID    | -              |  |
| Diam preset 0 [m]   | 1164 | Float  | 0.000   | 32.000  | 0                | 0                | ✓          | R/W                      | -     | -              |  |
| Diam preset 1 [m]   | 1165 | Float  | 0.000   | 32.000  | 0                | 0                | ✓          | R/W                      | -     | -              |  |
| Diam preset 2 [m]   | 1166 | Float  | 0.000   | 32.000  | 0                | 0                | ✓          | R/W                      | -     | -              |  |
| Diam preset 3 [m]   | 1167 | Float  | 0.000   | 32.000  | 0                | 0                | ✓          | R/W                      | IA    | -              |  |
| <b>OPTIONS \ TORQUE WINDER \ Torque calculat</b>                  |      |        |         |         |                  |                  |            |                          |       |                |  |
| Tension ref [%]   | 1180 | Float  | 0.00    | 199.99  | 0                | 0                | ✓          | R/W                      | IA    | -              |  |
| Tension scale [%]   | 1181 | I16    | 0       | 200     | 100              | 100              | ✓          | R/W                      | -     | -              |  |
| Act tension ref [%]   | 1194 | Float  | 0.00    | 199.99  |                  |                  | ✓          | R                        | -     | -              |  |
| Torque current [%]  | 1193 | Float  | 0.00    | 200.00  |                  |                  | ✓          | R                        | QA    | -              |  |
| <b>OPTIONS \ TORQUE WINDER \ Torque calculat \ Comp calculat</b>  |      |        |         |         |                  |                  |            |                          |       |                |  |
| Int acc calc En   | 1183 | U16    | 0       | 1       | Enabled<br>(1)   | Enabled<br>(1)   | ✓          | R/Z                      | -     | -              |  |
| Enabled<br>Disabled   |      |        |         |         |                  |                  |            | 1<br>0                   |       |                |  |
| Time acc/dec min [s]  | 1182 | Float  | 0.15    | 300.00  | 9.01             | 9.01             | ✓          | R/W                      | -     | -              |  |
| Acc/dec filter [ms]   | 1212 | U16    | 0       | 5000    | 30               | 30               | ✓          | R/W                      | -     | -              |  |
| Line acc [%]  | 1184 | Float  | 0.00    | 100.00  | 100              | 100              | ✓          | R/W                      | -     | -              |  |
| Line dec [%]  | 1185 | Float  | 0.00    | 100.00  | 100              | 100              | ✓          | R/W                      | -     | -              |  |
| Line fast stop [%]  | 1186 | Float  | 0.00    | 100.00  | 100              | 100              | ✓          | R/W                      | -     | -              |  |
| Line acc status   | 1188 | U16    | 0       | 1       | OFF              | OFF              | ✓          | R/W                      | ID    | R/W            |  |
| Line dec status   | 1189 | U16    | 0       | 1       | OFF              | OFF              | ✓          | R/W                      | ID    | R/W            |  |
| Line fstp status  | 1190 | U16    | 0       | 1       | OFF              | OFF              | ✓          | R/W                      | ID    | R/W            |  |
| Variable J comp [%]   | 1171 | Float  | 0.00    | 199.99  | 0                | 0                | ✓          | R/W                      | -     | -              |  |
| Constant J comp [%]   | 1172 | Float  | -100.00 | +100.00 | 0                | 0                | ✓          | R/W                      | -     | -              |  |
| Act var J comp [%]  | 1192 | Float  | -       | 200.00  | 0                | 0                | ✓          | R                        | -     | -              |  |
| Act const J comp [%]  | 1191 | Float  | -       | 200.00  | 0                | 0                | ✓          | R                        | -     | -              |  |
| Mat width [%]   | 1173 | Float  | 0.00    | 100.00  | 100              | 100              | ✓          | R/W                      | -     | -              |  |
| Static f [%]  | 1174 | Float  | 0.00    | 199.99  | 0                | 0                | ✓          | R/W                      | -     | -              |  |
| Dinamic f [%]   | 1175 | Float  | 0.00    | 199.99  | 0                | 0                | ✓          | R/W                      | -     | -              |  |
| Static f Zero   | 1287 | U16    | 0       | 1       | Disabled<br>(0)  | Disabled<br>(0)  | ✓          | R/W                      | -     | -              |  |
| Enabled<br>Disabled   |      |        |         |         |                  |                  |            | 1<br>0                   |       |                |  |
| Actual comp [%]   | 1213 | I16    | -200    | +200    |                  |                  | ✓          | R                        | QD    | -              |  |
| Closed loop En  | 1214 | U16    | 0       | 1       | Disabled<br>(0)  | Disabled<br>(0)  | ✓          | R/Z                      | -     | R/Z            |  |
| Enabled<br>Disabled   |      |        |         |         |                  |                  |            | 1<br>0                   |       |                |  |
| Close loop comp   | 1208 | I16    | -32767  | +32767  |                  |                  | ✓          | R                        | -     | -              |  |
| <b>OPTIONS \ TORQUE WINDER \ Torque calculat \ Taper function</b> |      |        |         |         |                  |                  |            |                          |       |                |  |
| Taper enable  | 1176 | U16    | 0       | 1       | Disabled<br>(0)  | Disabled<br>(0)  | ✓          | R/W                      | ID    | R/W            |  |
| Enabled<br>Disabled   |      |        |         |         |                  |                  |            | 1<br>0                   |       |                |  |
| Init diameter [m]   | 1177 | Float  | 0.000   | 32.000  | 0.1              | 0.1              | ✓          | R/W                      | -     | -              |  |
| Final diameter [m]  | 1178 | Float  | 0.000   | 32.000  | 1                | 1                | ✓          | R/W                      | -     | -              |  |
| Tension ref [%]   | 1180 | Float  | 0.00    | 199.99  | 0                | 0                | ✓          | R/W                      | IA    | -              |  |
| Tension red [%]   | 1179 | Float  | 0.00    | 199.99  | 0                | 0                | ✓          | R/W                      | IA    | -              |  |
| Act tension ref [%]   | 1194 | Float  | 0.00    | 200.00  | 0                | 0                | ✓          | R                        | QA    | -              |  |

| Parameter   | No.  | Format | Value  |                    |                  |                  | Access via |  |        |                |
|---|------|--------|--------|--------------------|------------------|------------------|------------|--|--------|----------------|
|   |      |        | min    | max                | Factory American | Factory European | Keyp.      | RS485/<br>BUS/<br>Opt2-M   | Term.  | Opt2-A/<br>PDC |
| <b>OPTIONS \ TORQUE WINDER \ Speed demand</b>   |      |        |        |                    |                  |                  |            |  |        |                |
| Speed demand En<br>Enabled<br>Disabled  | 1215 | U16    | 0      | 1                  | Disabled<br>(0)  | Disabled<br>(0)  | ✓          | R/W<br>1<br>0  | -      | R/W            |
| Winder side<br>Down<br>Up   | 1201 | U16    | 0      | 1                  | Up<br>(0)        | Up<br>(0)        | ✓          | R/W<br>1<br>0  | ID     | R/W            |
| W gain [%]  | 1202 | U16    | 0      | 100                | 0                | 0                | ✓          | R/W  | -      | -              |
| Speed match<br>ON<br>OFF  | 1195 | U16    | 0      | 1                  | OFF<br>(0)       | OFF<br>(0)       | ✓          | R/W<br>1<br>0  | ID     | R/W            |
| Spd match gain [%]  | 1200 | U16    | 0      | 150                | 100              | 100              | ✓          | R/W  | -      | -              |
| Spd match acc [s]   | 1196 | Float  | 0.30   | 300.00             | 83.88            | 83.88            | ✓          | R/W  | -      | -              |
| Spd match dec [s]   | 1197 | Float  | 0.30   | 300.00             | 83.88            | 83.88            | ✓          | R/W  | -      | -              |
| Spd match compl   | 1203 | U16    | 0      | 1                  |                  |                  | ✓          | R  | QD     | R              |
| Spd match torque [%]  | 1216 | U16    | 0      | 200                | 100              | 100              | ✓          | R/W  | -      | -              |
| W offset [rpm]  | 1199 | I16    | 0      | 1000               | 0                | 0                | ✓          | R/W  | -      | -              |
| Offset acc time [s]   | 1198 | Float  | 0.30   | 950.00             | 83.88            | 83.88            | ✓          | R/W  | -      | -              |
| W target  | 1210 | U16    | 0      | 65535              | 0                | 0                | ✓          | R/Z  | -      | -              |
| W reference [rpm]   | 1217 | I16    | -8192  | +8192              |                  |                  | ✓          | R  | QA     | -              |
| Jog TW enable<br>Enabled<br>Disabled  | 1256 | U16    | 0      | 1                  | Disabled<br>(0)  | Disabled<br>(0)  | ✓          | R/W<br>1<br>0  | ID     | R/W            |
| Jog TW speed [%]  | 1255 | I16    | 0      | 100                | 0                | 0                | ✓          | R/W  | -      | -              |
| <b>DRIVECOM</b>   |      |        |        |                    |                  |                  |            |  |        |                |
| Malfunction code<br>Failure supply<br>Undervoltage<br>Overvoltage<br>Overcurrent<br>Heatsink<br>Hardware<br>DSP error<br>Interrupt error<br>Speed fbk loss<br>External fault<br>Overtemp motor<br>Field loss<br>Bus loss<br>Hw opt 1 failure<br>Opt2<br>Unknown<br>Enable seq err | 57   | I16    |        |                    |                  |                  | ✓          | R<br>5100h<br>3120h<br>3310h<br>2300h<br>4210h<br>5000h<br>6110h<br>6120h<br>7301h<br>9000h<br>4310h<br>3330h<br>8110h<br>7510h<br>7400h<br>1001h<br>9009h | -      | -              |
| Control word  | 55   | U16    | 0      | 65535              |                  |                  | ✓          | R/W  | -      | R/W            |
| Status word   | 56   | U16    | 0      | 65535              |                  |                  | ✓          | R  | -      | R              |
| Speed input var [FF]  | 44   | I16    | -2 P45 | +2 P45             | 0                | 0                | ✓          | R/W  | IA, QA | R/W            |
| Speed ref var [FF]  | 115  | I16    | -32768 | +32767             | -                | -                | ✓          | R  | -      | R              |
| Act speed value [FF]  | 119  | I16    | -32768 | +32767             | -                | -                | ✓          | R  | -      | R              |
| <b>DRIVECOM \ Speed amount</b>  |      |        |        |                    |                  |                  |            |  |        |                |
| Speed min amount [FF]   | 1    | U32    | 0      | 2 <sup>32</sup> -1 | 0                | 0                | ✓          | R/Z  | -      | -              |
| Speed max amount [FF]   | 2    | U32    | 0      | 2 <sup>32</sup> -1 | 5000             | 5000             | ✓          | R/Z  | -      | -              |
| <b>DRIVECOM \ Speed min/max</b>   |      |        |        |                    |                  |                  |            |  |        |                |
| Speed min pos [FF]  | 5    | U32    | 0      | 2 <sup>32</sup> -1 | 0                | 0                | ✓          | R/Z  | -      | -              |
| Speed max pos [FF]  | 3    | U32    | 0      | 2 <sup>32</sup> -1 | 5000             | 5000             | ✓          | R/Z  | -      | -              |
| Speed min neg [FF]  | 6    | U32    | 0      | 2 <sup>32</sup> -1 | 0                | 0                | ✓          | R/Z  | -      | -              |
| Speed max neg [FF]  | 4    | U32    | 0      | 2 <sup>32</sup> -1 | 5000             | 5000             | ✓          | R/Z  | -      | -              |

| Parameter                         | No. | Format | Value  |                    |                  |                  | Access via |                          |       |                |
|-----------------------------------|-----|--------|--------|--------------------|------------------|------------------|------------|--------------------------|-------|----------------|
|                                   |     |        | min    | max                | Factory American | Factory European | Keyp.      | RS485/<br>BUS/<br>Opt2-M | Term. | Opt2-A/<br>PDC |
| <b>DRIVECOM \ Acceleration</b>    |     |        |        |                    |                  |                  |            |                          |       |                |
| Acc delta speed [FF]              | 21  | U32    | 0      | 2 <sup>32</sup> -1 | 100              | 100              | ✓          | R/W                      | -     | -              |
| Acc delta time [s]                | 22  | U16    | 0      | 65535              | 1                | 1                | ✓          | R/W                      | -     | -              |
| <b>DRIVECOM \ Deceleration</b>    |     |        |        |                    |                  |                  |            |                          |       |                |
| Dec delta speed [FF]              | 29  | U32    | 0      | 2 <sup>32</sup> -1 | 100              | 100              | ✓          | R/W                      | -     | -              |
| Dec delta time [s]                | 30  | U16    | 0      | 65535              | 1                | 1                | ✓          | R/W                      | -     | -              |
| <b>DRIVECOM \ Quick stop</b>      |     |        |        |                    |                  |                  |            |                          |       |                |
| QStp delta speed [FF]             | 37  | U32    | 0      | 2 <sup>32</sup> -1 | 1000             | 1000             | ✓          | R/W                      | -     | -              |
| QStp delta time [s]               | 38  | U16    | 0      | 65535              | 1                | 1                | ✓          | R/W                      | -     | -              |
| Quick stop                        | 343 | U16    | 0      | 1                  | No Quick stop    | No Quick stop    | -          | R/W                      | -     | -              |
| Quick stop<br>No Quick stop       |     |        |        |                    |                  |                  |            | 0<br>1                   |       |                |
| <b>DRIVECOM \ Face value fact</b> |     |        |        |                    |                  |                  |            |                          |       |                |
| Face value num                    | 54  | I16    | 1      | 32767              | 1                | 1                | ✓          | R/Z                      | -     | R              |
| Face value den                    | 53  | I16    | 1      | 32767              | 1                | 1                | ✓          | R/Z                      | -     | R              |
| <b>DRIVECOM \ Dimension fact</b>  |     |        |        |                    |                  |                  |            |                          |       |                |
| Dim factor num                    | 50  | I32*** | 1      | 65535              | 1                | 1                | ✓          | R/Z                      | -     | R              |
| Dim factor den                    | 51  | I32*** | 1      | 2 <sup>31</sup> -1 | 1                | 1                | ✓          | R/Z                      | -     | R              |
| Dim factor text                   | 52  | Text   |        |                    | rpm              | rpm              | ✓          | R/Z                      | -     | -              |
| <b>DRIVECOM</b>                   |     |        |        |                    |                  |                  |            |                          |       |                |
| Speed base value [FF]             | 45  | U32*** | 1      | 16383              | 1500             | 1500             | ✓          | R/Z                      | -     | R              |
| Speed input perc [%]              | 46  | I16    | -32768 | +32767             | 0                | 0                | ✓          | R/W                      | -     | R/W            |
| Percent ref var [%]               | 116 | I16    | -32768 | +32767             |                  |                  | ✓          | R                        | -     | R              |
| Act percentage [%]                | 120 | I16    | -32768 | +32767             |                  |                  | ✓          | R                        | -     | R              |
| <b>SERVICE</b>                    |     |        |        |                    |                  |                  |            |                          |       |                |
| Password 2                        |     |        |        |                    |                  |                  |            |                          |       |                |

\* When the parameter is accessed by Opt2-A/PDC the format is U16

\*\* When the parameter is accessed by Opt2-A/PDC the format is I16

\*\*\* When the parameter is accessed by Opt2-A/PDC the lower word of the parameter is considered

## 10.2 NUMERICAL LIST

| Parameter             | No. | Format | Value |                    |                  |                  | Access via |                          |        |                |
|-----------------------|-----|--------|-------|--------------------|------------------|------------------|------------|--------------------------|--------|----------------|
|                       |     |        | min   | max                | Factory American | Factory European | Keyp.      | RS485/<br>BUS/<br>Opt2-M | Term.  | Opt2-A/<br>PDC |
| Digital I/Q           |     |        |       |                    | -                | -                | ✓          | -                        | -      | -              |
| Speed min amount [FF] | 1   | U32    | 0     | 2 <sup>32</sup> -1 | 0                | 0                | ✓          | R/Z                      | -      | -              |
| Speed max amount [FF] | 2   | U32    | 0     | 2 <sup>32</sup> -1 | 5000             | 5000             | ✓          | R/Z                      | -      | -              |
| Speed max pos [FF]    | 3   | U32    | 0     | 2 <sup>32</sup> -1 | 5000             | 5000             | ✓          | R/Z                      | -      | -              |
| Speed max neg [FF]    | 4   | U32    | 0     | 2 <sup>32</sup> -1 | 5000             | 5000             | ✓          | R/Z                      | -      | -              |
| Speed min pos [FF]    | 5   | U32    | 0     | 2 <sup>32</sup> -1 | 0                | 0                | ✓          | R/Z                      | -      | -              |
| Speed min pos [FF]    | 5   | U32    | 0     | 2 <sup>32</sup> -1 | 0                | 0                | ✓          | R/Z                      | -      | -              |
| Speed min neg [FF]    | 6   | U32    | 0     | 2 <sup>32</sup> -1 | 0                | 0                | ✓          | R/Z                      | -      | -              |
| T current lim [%]     | 7   | U16    | 0     | 200                | 150              | 150              | ✓          | R/W                      | IA     | R/W            |
| T current lim + [%]   | 8   | U16    | 0     | 200                | 150              | 150              | ✓          | R/W                      | IA     | R/W            |
| T current lim - [%]   | 9   | U16    | 0     | 200                | 150              | 150              | ✓          | R/W                      | IA     | R/W            |
| In use Tcur lim+ [%]  | 10  | U16    | 0     | 200                |                  |                  | ✓          | R                        | -      | R              |
| In use Tcur lim- [%]  | 11  | U16    | 0     | 200                |                  |                  | ✓          | R                        | -      | R              |
| Current lim red [%]   | 13  | U16    | 0     | 200                | 100              | 100              | ✓          | R/W                      | -      | R/W            |
| Ramp shape            | 18  | U16    | 0     | 1                  | Linear (0)       | Linear (0)       | ✓          | R/Z                      | -      | -              |
|                       |     |        |       |                    |                  |                  |            | 0<br>1                   |        |                |
| S shape t const [ms]  | 19  | Float  | 100   | 3000               | 300              | 300              | ✓          | R/W                      | -      | -              |
| Ramp +/- delay [ms]   | 20  | U16    | 0     | 65535              | 100              | 100              | ✓          | R/W                      | -      | -              |
| Acc delta speed [FF]  | 21  | U32    | 0     | 2 <sup>32</sup> -1 | 100              | 100              | ✓          | R/W                      | -      | -              |
| Acc delta time [s]    | 22  | U16    | 0     | 65535              | 1                | 1                | ✓          | R/W                      | -      | -              |
| Acc delta speed1 [FF] | 23  | U32    | 0     | 2 <sup>32</sup> -1 | 100              | 100              | ✓          | R/W                      | -      | -              |
| Acc delta time 1 [s]  | 24  | U16    | 0     | 65535              | 1                | 1                | ✓          | R/W                      | -      | -              |
| Acc delta speed2 [FF] | 25  | U32    | 0     | 2 <sup>32</sup> -1 | 100              | 100              | ✓          | R/W                      | -      | -              |
| Acc delta time 2 [s]  | 26  | U16    | 0     | 65535              | 1                | 1                | ✓          | R/W                      | -      | -              |
| Acc delta speed3 [FF] | 27  | U32    | 0     | 2 <sup>32</sup> -1 | 100              | 100              | ✓          | R/W                      | -      | -              |
| Acc delta time 3 [s]  | 28  | U16    | 0     | 65535              | 1                | 1                | ✓          | R/W                      | -      | -              |
| Dec delta speed [FF]  | 29  | U32    | 0     | 2 <sup>32</sup> -1 | 100              | 100              | ✓          | R/W                      | -      | -              |
| Dec delta time [s]    | 30  | U16    | 0     | 65535              | 1                | 1                | ✓          | R/W                      | -      | -              |
| Dec delta speed1 [FF] | 31  | U32    | 0     | 2 <sup>32</sup> -1 | 100              | 100              | ✓          | R/W                      | -      | -              |
| Dec delta time 1 [s]  | 32  | U16    | 0     | 65535              | 1                | 1                | ✓          | R/W                      | -      | -              |
| Dec delta speed2 [FF] | 33  | U32    | 0     | 2 <sup>32</sup> -1 | 100              | 100              | ✓          | R/W                      | -      | -              |
| Dec delta time 2 [s]  | 34  | U16    | 0     | 65535              | 1                | 1                | ✓          | R/W                      | -      | -              |
| Dec delta speed3 [FF] | 35  | U32    | 0     | 2 <sup>32</sup> -1 | 100              | 100              | ✓          | R/W                      | -      | -              |
| Dec delta time 3 [s]  | 36  | U16    | 0     | 65535              | 1                | 1                | ✓          | R/W                      | -      | -              |
| QStp delta speed [FF] | 37  | U32    | 0     | 2 <sup>32</sup> -1 | 1000             | 1000             | ✓          | R/W                      | -      | -              |
| QStp delta time [s]   | 38  | U16    | 0     | 65535              | 1                | 1                | ✓          | R/W                      | -      | -              |
| T current ref 1 [%]   | 39  | I16    | -200  | +200<br>see 6.4.3  | 0                | 0                | ✓          | R/W                      | IA, QA | R/W            |

| Parameter             | No. | Format | Value   |                     |                  |                  | Access via |                          |        |                |
|-----------------------|-----|--------|---------|---------------------|------------------|------------------|------------|--------------------------|--------|----------------|
|                       |     |        | min     | max                 | Factory American | Factory European | Keyp.      | RS485/<br>BUS/<br>Opt2-M | Term.  | Opt2-A/<br>PDC |
| T current ref 2 [%]   | 40  | I16    | -200    | +200                | 0.00             | 0.00             | ✓          | R/W                      | IA, QA | -              |
| T current ref [%]     | 41  | I16    | -200    | +200                | -                | -                | ✓          | R                        | QA     | R              |
| Speed ref 1 [FF]      | 42  | I16    | -2 P45  | +2 P45              | 0                | 0                | ✓          | R/W                      | IA, QA | R/W            |
| Speed ref 2 [FF]      | 43  | I16    | -2 P45  | +2 P45              | 0                | 0                | ✓          | R/W                      | IA, QA | R/W            |
| Ramp ref 1 [FF]       | 44  | I16    | -2 P45  | +2 P45              | 0                | 0                | ✓          | R/W                      | IA, QA | R/W            |
| Speed base value [FF] | 45  | U32*** | 1       | 16383               | 1500             | 1500             | ✓          | R/Z                      | -      | R              |
| Speed input perc [%]  | 46  | I16    | -32768  | +32767              | 0                | 0                | ✓          | R/W                      | -      | R/W            |
| Ramp ref 1 (%)        | 47  | Float  | -200.0  | +200.0              | 0.0              | 0.0              | ✓          | R/W                      | -      | -              |
| Ramp ref 2 [FF]       | 48  | I16    | -2 P45  | +2 P45              | 0                | 0                | ✓          | R/W                      | IA, QA | R/W            |
| Ramp ref 2 (%)        | 49  | Float  | -200.0  | +200.0              | 0.0              | 0.0              | ✓          | R/W                      | -      | -              |
| Dim factor num        | 50  | I32*** | 1       | 65535               | 1                | 1                | ✓          | R/Z                      | -      | R              |
| Dim factor den        | 51  | I32*** | 1       | +2 <sup>31</sup> -1 | 1                | 1                | ✓          | R/Z                      | -      | R              |
| Dim factor text       | 52  | Text   |         |                     | rpm              | rpm              | ✓          | R/Z                      | -      | -              |
| Face value den        | 53  | I16    | 1       | +32767              | 1                | 1                | ✓          | R/Z                      | -      | R              |
| Face value num        | 54  | I16    | 1       | +32767              | 1                | 1                | ✓          | R/Z                      | -      | R              |
| Control word          | 55  | U16    | 0       | 65535               |                  |                  | ✓          | R/W                      | -      | R/W            |
| Status word           | 56  | U16    | 0       | 65535               |                  |                  | ✓          | R                        | -      | R              |
| Malfunction code      | 57  | I16    |         |                     |                  |                  | ✓          | R                        | -      | -              |
| Failure supply        |     |        |         |                     |                  |                  | 5100h      | 5100h                    |        |                |
| Undervoltage          |     |        |         |                     |                  |                  | 3120h      | 3120h                    |        |                |
| Overvoltage           |     |        |         |                     |                  |                  | 3310h      | 3310h                    |        |                |
| Overcurrent           |     |        |         |                     |                  |                  | 2300h      | 2300h                    |        |                |
| Heatsink              |     |        |         |                     |                  |                  | 4210h      | 4210h                    |        |                |
| Hardware              |     |        |         |                     |                  |                  | 5000h      | 5000h                    |        |                |
| DSP error             |     |        |         |                     |                  |                  | 6110h      | 6110h                    |        |                |
| Interrupt error       |     |        |         |                     |                  |                  | 6120h      | 6120h                    |        |                |
| Speed fbk loss        |     |        |         |                     |                  |                  | 7301h      | 7301h                    |        |                |
| External fault        |     |        |         |                     |                  |                  | 9000h      | 9000h                    |        |                |
| Overtemp motor        |     |        |         |                     |                  |                  | 4310h      | 4310h                    |        |                |
| Field loss            |     |        |         |                     |                  |                  | 3330h      | 3330h                    |        |                |
| Bus loss              |     |        |         |                     |                  |                  | 8110h      | 8110h                    |        |                |
| Hw opt 1 failure      |     |        |         |                     |                  |                  | 7510h      | 7510h                    |        |                |
| Opt2                  |     |        |         |                     |                  |                  | 7400h      | 7400h                    |        |                |
| Unknown               |     |        |         |                     |                  |                  | 1001h      | 1001h                    |        |                |
| Enable seq err        |     |        |         |                     |                  |                  | 9009h      | 9009h                    |        |                |
| Generator access      | 58  | U16    | 0       | 5                   | Not conn.        | Not conn.        | ✓          | R/Z                      | -      | -              |
| Not connected         |     |        |         |                     |                  |                  |            | 0                        |        |                |
| T current ref         |     |        |         |                     |                  |                  |            | 2                        |        |                |
| Flux ref              |     |        |         |                     |                  |                  |            | 3                        |        |                |
| Ramp ref              |     |        |         |                     |                  |                  |            | 4                        |        |                |
| Speed ref             |     |        |         |                     |                  |                  |            | 5                        |        |                |
| Gen frequency [Hz]    | 59  | Float  | 0.1     | 62.5                | 0.1              | 0.1              | ✓          | R/W                      | -      | -              |
| Gen amplitude [%]     | 60  | Float  | 0       | 200.00              | 0                | 0                | ✓          | R/W                      | -      | -              |
| Generator offset [%]  | 61  | Float  | -200.00 | +200.00             | 0                | 0                | ✓          | R/W                      | -      | -              |
| Scale output 1        | 62  | Float  | -10.000 | +10.000             | 0.000            | 0.000            | ✓          | R/W                      | -      | -              |
| Scale output 2        | 63  | Float  | -10.000 | +10000              | 0.000            | 0.000            | ✓          | R/W                      | -      | -              |
| Scale output 3        | 64  | Float  | -10.000 | +10000              | 0.000            | 0.000            | ✓          | R/W                      | -      | -              |
| Scale output 4        | 65  | Float  | -10.000 | +10000              | 0.000            | 0.000            | ✓          | R/W                      | -      | -              |

| Parameter                                 | No. | Format | Value |     |                     |                     | Access via |                          |       |                |
|---|-----|--------|-------|-----|---------------------|---------------------|------------|--------------------------|-------|----------------|
|   |     |        | min   | max | Factory American    | Factory European    | Key.       | RS485/<br>BUS/<br>Opt2-M | Term. | Opt2-A/<br>PDC |
| Select output 1                           | 66  | U16    | 0     | 94  | Actual speed (8)    | Actual speed (8)    | ✓          | R/Z                      | -     | -              |
| OFF                                       |     |        |       |     |                     |                     |            | 0                        |       |                |
| Speed ref 1                               |     |        |       |     |                     |                     |            | 1                        |       |                |
| Speed ref 2                               |     |        |       |     |                     |                     |            | 2                        |       |                |
| Ramp ref 1                                |     |        |       |     |                     |                     |            | 3                        |       |                |
| Ramp ref 2                                |     |        |       |     |                     |                     |            | 4                        |       |                |
| Ramp ref                                  |     |        |       |     |                     |                     |            | 5                        |       |                |
| Speed ref                                 |     |        |       |     |                     |                     |            | 6                        |       |                |
| Ramp out                                  |     |        |       |     |                     |                     |            | 7                        |       |                |
| Actual speed                              |     |        |       |     |                     |                     |            | 8                        |       |                |
| T current ref 1                           |     |        |       |     |                     |                     |            | 9                        |       |                |
| T current ref 2                           |     |        |       |     |                     |                     |            | 10                       |       |                |
| T current ref                             |     |        |       |     |                     |                     |            | 11                       |       |                |
| Speed reg out                             |     |        |       |     |                     |                     |            | 15                       |       |                |
| Motor current                             |     |        |       |     |                     |                     |            | 16                       |       |                |
| Output voltage                            |     |        |       |     |                     |                     |            | 20                       |       |                |
| Analog input 1                            |     |        |       |     |                     |                     |            | 24                       |       |                |
| Analog input 2                            |     |        |       |     |                     |                     |            | 25                       |       |                |
| Analog input 3                            |     |        |       |     |                     |                     |            | 26                       |       |                |
| Flux current                              |     |        |       |     |                     |                     |            | 27                       |       |                |
| Pad 0                                     |     |        |       |     |                     |                     |            | 31                       |       |                |
| Pad 1                                     |     |        |       |     |                     |                     |            | 32                       |       |                |
| Pad 4                                     |     |        |       |     |                     |                     |            | 33                       |       |                |
| Pad 5                                     |     |        |       |     |                     |                     |            | 34                       |       |                |
| Flux reference                            |     |        |       |     |                     |                     |            | 35                       |       |                |
| Pad 6                                     |     |        |       |     |                     |                     |            | 38                       |       |                |
| PID output                                |     |        |       |     |                     |                     |            | 39                       |       |                |
| Out vlt level                             |     |        |       |     |                     |                     |            | 79                       |       |                |
| Flux current max                          |     |        |       |     |                     |                     |            | 80                       |       |                |
| F act spd                                 |     |        |       |     |                     |                     |            | 81                       |       |                |
| F T curr                                  |     |        |       |     |                     |                     |            | 82                       |       |                |
| Speed draw out                            |     |        |       |     |                     |                     |            | 84                       |       |                |
| Output power                              |     |        |       |     |                     |                     |            | 88                       |       |                |
| Roll diameter                             |     |        |       |     |                     |                     |            | 89                       |       |                |
| Act tension ref                           |     |        |       |     |                     |                     |            | 90                       |       |                |
| Torque current                            |     |        |       |     |                     |                     |            | 91                       |       |                |
| W reference                               |     |        |       |     |                     |                     |            | 92                       |       |                |
| Actual comp                               |     |        |       |     |                     |                     |            | 93                       |       |                |
| Brake current                             |     |        |       |     |                     |                     |            | 94                       |       |                |
| Select output 2<br>(Select like output 1) | 67  | U16    | 0     | 94  | Motor current (16)  | Motor current (16)  | ✓          | R/Z                      | -     | -              |
| Select output 3<br>(Select like output 1) | 68  | U16    | 0     | 94  | Flux -27            | Flux -27            | ✓          | R/Z                      | -     | -              |
| Select output 4<br>(Select like output 1) | 69  | U16    | 0     | 94  | Output voltage (20) | Output voltage (20) | ✓          | R/Z                      | -     | -              |

| Parameter                               | No. | Format | Value   |        |                           |                           | Access via |                          |       |                |
|---|-----|--------|---------|--------|---------------------------|---------------------------|------------|--------------------------|-------|----------------|
|   |     |        | min     | max    | Factory American          | Factory European          | Keyp.      | RS485/<br>BUS/<br>Opt2-M | Term. | Opt2-A/<br>PDC |
| Select input 1                          | 70  | U16    | 0       | 32     | Ramp ref 1 (4)            | Ramp ref 1 (4)            | ✓          | R/Z                      | -     | -              |
| OFF                                     |     |        |         |        |                           |                           |            | 0                        |       |                |
| Jog reference                           |     |        |         |        |                           |                           |            | 1                        |       |                |
| Speed ref 1                             |     |        |         |        |                           |                           |            | 2                        |       |                |
| Speed ref 2                             |     |        |         |        |                           |                           |            | 3                        |       |                |
| Ramp ref 1                              |     |        |         |        |                           |                           |            | 4                        |       |                |
| Ramp ref 2                              |     |        |         |        |                           |                           |            | 5                        |       |                |
| T current ref 1                         |     |        |         |        |                           |                           |            | 6                        |       |                |
| T current ref 2                         |     |        |         |        |                           |                           |            | 7                        |       |                |
| Adap reference                          |     |        |         |        |                           |                           |            | 8                        |       |                |
| T current limit                         |     |        |         |        |                           |                           |            | 9                        |       |                |
| T current lim +                         |     |        |         |        |                           |                           |            | 10                       |       |                |
| T current lim -                         |     |        |         |        |                           |                           |            | 11                       |       |                |
| Pad 0                                   |     |        |         |        |                           |                           |            | 12                       |       |                |
| Pad 1                                   |     |        |         |        |                           |                           |            | 13                       |       |                |
| Pad 2                                   |     |        |         |        |                           |                           |            | 14                       |       |                |
| Pad 3                                   |     |        |         |        |                           |                           |            | 15                       |       |                |
| Load comp                               |     |        |         |        |                           |                           |            | 19                       |       |                |
| PID offset 0                            |     |        |         |        |                           |                           |            | 21                       |       |                |
| PI central v3                           |     |        |         |        |                           |                           |            | 22                       |       |                |
| PID feed-back                           |     |        |         |        |                           |                           |            | 23                       |       |                |
| Max field curr<br>(Max field curr)      |     |        |         |        |                           |                           |            | 25                       |       |                |
| Out vlt level                           |     |        |         |        |                           |                           |            | 26                       |       |                |
| Speed ratio                             |     |        |         |        |                           |                           |            | 28                       |       |                |
| Tension red                             |     |        |         |        |                           |                           |            | 29                       |       |                |
| Tension ref                             |     |        |         |        |                           |                           |            | 30                       |       |                |
| Preset 3                                |     |        |         |        |                           |                           |            | 31                       |       |                |
| Brake Ref                               |     |        |         |        |                           |                           |            | 32                       |       |                |
| Input 1 type                            | 71  | U16    | 0       | 2      | ± 10 V                    | ± 10 V                    | ✓          | R/Z                      | -     | -              |
| -10V ... + 10 V                         |     |        |         |        |                           |                           |            | 0                        |       |                |
| 0...20 mA, 0...10 V                     |     |        |         |        |                           |                           |            | 1                        |       |                |
| 4...20 mA                               |     |        |         |        |                           |                           |            | 2                        |       |                |
| Scale input 1                           | 72  | Float  | -10000  | +10000 | 1.000                     | 1.000                     | ✓          | R/W                      | -     | -              |
| Tune value inp 1                        | 73  | Float  | 0.100   | 10.000 | 1.000                     | 1.000                     | ✓          | R/W                      | -     | -              |
| Offset input 1                          | 74  | I16    | -32768  | +32767 | 0                         | 0                         | ✓          | R/W                      | -     | -              |
| Select input 2<br>(Select like Input 1) | 75  | U16    | 0       | 32     | OFF (0)                   | OFF (0)                   | ✓          | R/Z                      | -     | -              |
| Input 2 type                            | 76  | U16    | 0       | 2      | ± 10 V                    | ± 10 V                    | ✓          | R/Z                      | -     | -              |
| -10V ... + 10 V                         |     |        |         |        |                           |                           |            | 0                        |       |                |
| 0...20 mA, 0...10 V                     |     |        |         |        |                           |                           |            | 1                        |       |                |
| 4...20 mA                               |     |        |         |        |                           |                           |            | 2                        |       |                |
| Scale input 2                           | 77  | Float  | -10.000 | +10000 | 1.000                     | 1.000                     | ✓          | R/W                      | -     | -              |
| Tune value inp 2                        | 78  | Float  | 0.100   | 10.000 | 1.000                     | 1.000                     | ✓          | R/W                      | -     | -              |
| Offset input 2                          | 79  | I16    | -32768  | +32767 | 0                         | 0                         | ✓          | R/W                      | -     | -              |
| Select input 3<br>(Select like Input 1) | 80  | U16    | 0       | 32     | OFF (0)                   | OFF (0)                   | ✓          | R/Z                      | -     | -              |
| Input 3 type                            | 81  | U16    | 0       | 2      | ± 10 V                    | ± 10 V                    | ✓          | R/Z                      | -     | -              |
| -10V ... + 10 V                         |     |        |         |        |                           |                           |            | 0                        |       |                |
| 0...20 mA, 0...10 V                     |     |        |         |        |                           |                           |            | 1                        |       |                |
| 4...20 mA                               |     |        |         |        |                           |                           |            | 2                        |       |                |
| Scale input 3                           | 82  | Float  | -10.000 | +10000 | 1.000                     | 1.000                     | ✓          | R/W                      | -     | -              |
| Tune value inp 3                        | 83  | Float  | 0.100   | 10.000 | 1.000                     | 1.000                     | ✓          | R/W                      | -     | -              |
| Offset input 3                          | 84  | I16    | -32768  | +32767 | 0                         | 0                         | ✓          | R/W                      | -     | -              |
| Pword 1                                 | 85  | I32    | 0       | 99999  | 0                         | 0                         | ✓          | W                        | -     | -              |
| Speed P [%]                             | 87  | Float  | 0.00    | 100.00 | S                         | S                         | ✓          | R/W                      | -     | -              |
| Speed I [%]                             | 88  | Float  | 0.00    | 100.00 | S                         | S                         | ✓          | R/W                      | -     | -              |
| Flux P [%]                              | 91  | Float  | 0.00    | 100.00 | 2.00                      | 2.00                      | ✓          | R/W                      | -     | -              |
| Flux I [%]                              | 92  | Float  | 0.00    | 100.00 | 1.00                      | 1.00                      | ✓          | R/W                      | -     | -              |
| Speed P base [A/rpm]                    | 93  | Float  | 000.1   | S      | 0.3 x<br>P93max<br>P93max | 0.3 x<br>P93max<br>P93max | ✓          | R/Z                      | -     | -              |
| Speed I base [A/rpm.ms]                 | 94  | Float  | 0.001   | S      | 0.3<br>P94max             | 0.3<br>P94max             | ✓          | R/Z                      | -     | -              |



| Parameter                             | No. | Format | Value  |        |                  |                  | Access via |                          |       |                |
|---------------------------------------|-----|--------|--------|--------|------------------|------------------|------------|--------------------------|-------|----------------|
|                                       |     |        | min    | max    | Factory American | Factory European | Keyp.      | RS485/<br>BUS/<br>Opt2-M | Term. | Opt2-A/<br>PDC |
| Flux P base                           | 97  | Float  | 1      | 32767  | 3277             | 3277             | ✓          | R/Z                      | -     | -              |
| Flux I Base                           | 98  | Float  | 1      | 32767  | 3277             | 3277             | ✓          | R/Z                      | -     | -              |
| Speed P in use [%]                    | 99  | Float  | 0.00   | 100.00 | S                | S                | ✓          | R                        | -     | -              |
| Speed I in use [%]                    | 100 | Float  | 0.00   | 100.00 | S                | S                | ✓          | R                        | -     | -              |
| Spd threshold + [FF]                  | 101 | U16    | 1      | 32767  | 1000             | 1000             | ✓          | R/W                      | -     | -              |
| Spd threshold - [FF]                  | 102 | U16    | 1      | 32767  | 1000             | 1000             | ✓          | R/W                      | -     | -              |
| Threshold delay [ms]                  | 103 | U16    | 0      | 65535  | 100              | 100              | ✓          | R/W                      | -     | -              |
| Set error [FF]                        | 104 | U16    | 1      | 32767  | 100              | 100              | ✓          | R/W                      | -     | -              |
| Set delay [ms]                        | 105 | U16    | 1      | 65535  | 100              | 100              | ✓          | R/W                      | -     | -              |
| Ref 0 level [FF]                      | 106 | U16    | 1      | 32767  | 10               | 10               | ✓          | R/W                      | -     | -              |
| Speed zero level [FF]                 | 107 | U16    | 1      | 32767  | 10               | 10               | ✓          | R/W                      | -     | -              |
| Speed zero delay [ms]                 | 108 | U16    | 0      | 65535  | 100              | 100              | ✓          | R/W                      | -     | -              |
| Ramp ref (d) [FF]                     | 109 | I16    | -32768 | +32767 | -                | -                | ✓          | R                        | -     | R              |
| Ramp ref (rpm)                        | 110 | I16    | -32768 | +32767 | -                | -                | ✓          | R                        | QA    | R              |
| Ramp ref (%)                          | 111 | Float  | -200.0 | +200.0 | -                | -                | ✓          | R                        | -     | -              |
| Ramp output (d) [FF]                  | 112 | I16    | -32768 | +32767 | -                | -                | ✓          | R                        | -     | R              |
| Ramp outp (rpm)                       | 113 | I16    | -32768 | +32767 | -                | -                | ✓          | R                        | QA    | R              |
| Ramp output (%)                       | 114 | Float  | -200.0 | +200.0 | -                | -                | ✓          | R                        | -     | -              |
| Speed ref (d) [FF]                    | 115 | I16    | -32768 | +32767 | -                | -                | ✓          | R                        | -     | R              |
| Percent ref var [%]                   | 116 | I16    | -32768 | +32767 | -                | -                | ✓          | R                        | -     | R              |
| Speed ref (%)                         | 117 | Float  | -200.0 | +200.0 | -                | -                | ✓          | R                        | -     | -              |
| Speed ref (rpm)                       | 118 | I16    | -32768 | +32767 | -                | -                | ✓          | R                        | QA    | R              |
| Actual spd (d) [FF]                   | 119 | I16    | -32768 | +32767 | -                | -                | ✓          | R                        | -     | R              |
| Act percentage [%]                    | 120 | I16    | -32768 | +32767 | -                | -                | ✓          | R                        | -     | R              |
| Actual spd (%)                        | 121 | Float  | -200.0 | +200.0 | -                | -                | ✓          | R                        | -     | -              |
| Actual spd (rpm)                      | 122 | I16    | -8192  | +8192  | -                | -                | ✓          | R                        | QA    | R              |
| Enable spd=0 I<br>Enabled<br>Disabled | 123 | U16    | 0      | 1      | Disabled         | Disabled         | ✓          | R/Z<br>1<br>0            | -     | -              |
| Enable spd=0 R<br>Enabled<br>Disabled | 124 | U16    | 0      | 1      | Disabled         | Disabled         | ✓          | R/Z<br>1<br>0            | -     | -              |
| Enable spd=0 P<br>Enabled<br>Disabled | 125 | U16    | 0      | 1      | Disabled         | Disabled         | ✓          | R/Z<br>1<br>0            | -     | -              |
| Spd=0 P gain [%]                      | 126 | Float  | 0.00   | 100.00 | 10.00            | 10.00            | ✓          | R/W                      | -     | -              |

| Parameter                                | No. | Format | Value |     |                  |                  | Access via |                          |       |                |
|--|-----|--------|-------|-----|------------------|------------------|------------|--------------------------|-------|----------------|
|  |     |        | min   | max | Factory American | Factory European | Keyp.      | RS485/<br>BUS/<br>Opt2-M | Term. | Opt2-A/<br>PDC |
| Digital input 1                          | 137 | U16    | 0     | 87  | OFF (0)          | OFF (0)          | ✓          | R/Z                      | -     | -              |
| OFF                                      |     |        |       |     |                  |                  |            | 0                        |       |                |
| Motor pot reset                          |     |        |       |     |                  |                  |            | 1                        |       |                |
| Motor pot up                             |     |        |       |     |                  |                  |            | 2                        |       |                |
| Motor pot down                           |     |        |       |     |                  |                  |            | 3                        |       |                |
| Motor pot sign +                         |     |        |       |     |                  |                  |            | 4                        |       |                |
| Motor pot sign -                         |     |        |       |     |                  |                  |            | 5                        |       |                |
| Jog +                                    |     |        |       |     |                  |                  |            | 6                        |       |                |
| Jog -                                    |     |        |       |     |                  |                  |            | 7                        |       |                |
| Failure reset                            |     |        |       |     |                  |                  |            | 8                        |       |                |
| Torque reduct                            |     |        |       |     |                  |                  |            | 9                        |       |                |
| Ramp out = 0                             |     |        |       |     |                  |                  |            | 10                       |       |                |
| Ramp in = 0                              |     |        |       |     |                  |                  |            | 11                       |       |                |
| Freeze ramp                              |     |        |       |     |                  |                  |            | 12                       |       |                |
| Lock speed reg                           |     |        |       |     |                  |                  |            | 13                       |       |                |
| Lock speed 1                             |     |        |       |     |                  |                  |            | 14                       |       |                |
| Auto capture                             |     |        |       |     |                  |                  |            | 15                       |       |                |
| Input 1 sign +                           |     |        |       |     |                  |                  |            | 16                       |       |                |
| Input 1 sign -                           |     |        |       |     |                  |                  |            | 17                       |       |                |
| Input 2 sign +                           |     |        |       |     |                  |                  |            | 18                       |       |                |
| Input 2 sign -                           |     |        |       |     |                  |                  |            | 19                       |       |                |
| Input 3 sign +                           |     |        |       |     |                  |                  |            | 20                       |       |                |
| Input 3 sign -                           |     |        |       |     |                  |                  |            | 21                       |       |                |
| Zero torque                              |     |        |       |     |                  |                  |            | 22                       |       |                |
| Speed sel 0                              |     |        |       |     |                  |                  |            | 23                       |       |                |
| Speed sel 1                              |     |        |       |     |                  |                  |            | 24                       |       |                |
| Speed sel 2                              |     |        |       |     |                  |                  |            | 25                       |       |                |
| Ramp sel 0                               |     |        |       |     |                  |                  |            | 26                       |       |                |
| Ramp sel 1                               |     |        |       |     |                  |                  |            | 27                       |       |                |
| Field loss                               |     |        |       |     |                  |                  |            | 29                       |       |                |
| Enable flux reg                          |     |        |       |     |                  |                  |            | 30                       |       |                |
| Enable flux weak                         |     |        |       |     |                  |                  |            | 31                       |       |                |
| Pad A bit 0                              |     |        |       |     |                  |                  |            | 32                       |       |                |
| Pad A bit 1                              |     |        |       |     |                  |                  |            | 33                       |       |                |
| Pad A bit 2                              |     |        |       |     |                  |                  |            | 34                       |       |                |
| Pad A bit 3                              |     |        |       |     |                  |                  |            | 35                       |       |                |
| Pad A bit 4                              |     |        |       |     |                  |                  |            | 36                       |       |                |
| Pad A bit 5                              |     |        |       |     |                  |                  |            | 37                       |       |                |
| Pad A bit 6                              |     |        |       |     |                  |                  |            | 38                       |       |                |
| Pad A bit 7                              |     |        |       |     |                  |                  |            | 39                       |       |                |
| Forward sign                             |     |        |       |     |                  |                  |            | 44                       |       |                |
| Reverse sign                             |     |        |       |     |                  |                  |            | 45                       |       |                |
| An in 1 target                           |     |        |       |     |                  |                  |            | 46                       |       |                |
| An in 2 target                           |     |        |       |     |                  |                  |            | 47                       |       |                |
| An in 3 target                           |     |        |       |     |                  |                  |            | 48                       |       |                |
| Enable droop                             |     |        |       |     |                  |                  |            | 49                       |       |                |
| Enable PI PID                            |     |        |       |     |                  |                  |            | 52                       |       |                |
| Enable PD PID                            |     |        |       |     |                  |                  |            | 53                       |       |                |
| PI integral freeze                       |     |        |       |     |                  |                  |            | 54                       |       |                |
| PID offs. Sel                            |     |        |       |     |                  |                  |            | 55                       |       |                |
| PI central vs0                           |     |        |       |     |                  |                  |            | 56                       |       |                |
| PI central vs1                           |     |        |       |     |                  |                  |            | 57                       |       |                |
| Diameter calc                            |     |        |       |     |                  |                  |            | 58                       |       |                |
| Diam reset                               |     |        |       |     |                  |                  |            | 68                       |       |                |
| Diam calc Dis                            |     |        |       |     |                  |                  |            | 69                       |       |                |
| Torque winder EN                         |     |        |       |     |                  |                  |            | 70                       |       |                |
| Line acc status                          |     |        |       |     |                  |                  |            | 71                       |       |                |
| Line dec status                          |     |        |       |     |                  |                  |            | 72                       |       |                |
| Line fstp status                         |     |        |       |     |                  |                  |            | 73                       |       |                |
| Speed match                              |     |        |       |     |                  |                  |            | 74                       |       |                |
| Diam inc/dec En                          |     |        |       |     |                  |                  |            | 75                       |       |                |
| Wind/unwind                              |     |        |       |     |                  |                  |            | 76                       |       |                |
| Diam preset sel0                         |     |        |       |     |                  |                  |            | 77                       |       |                |
| Diam preset sel1                         |     |        |       |     |                  |                  |            | 78                       |       |                |
| Taper enable                             |     |        |       |     |                  |                  |            | 79                       |       |                |
| Speed demand En                          |     |        |       |     |                  |                  |            | 80                       |       |                |
| Winder side                              |     |        |       |     |                  |                  |            | 81                       |       |                |
| Enable PI-PD PID                         |     |        |       |     |                  |                  |            | 82                       |       |                |
| Jog TW enable                            |     |        |       |     |                  |                  |            | 83                       |       |                |
| Brake fbk                                |     |        |       |     |                  |                  |            | 84                       |       |                |
| Adapt Sel 1                              |     |        |       |     |                  |                  |            | 86                       |       |                |
| Adapt Sel 2                              |     |        |       |     |                  |                  |            | 87                       |       |                |
| Digital input 2<br>(Select like input 1) | 138 | U16    | 0     | 87  | OFF (0)          | OFF (0)          | ✓          | R/Z                      | -     | -              |

| Parameter                                  | No. | Format | Value |     |                      |                      | Access via |                          |       |                |
|--|-----|--------|-------|-----|----------------------|----------------------|------------|--------------------------|-------|----------------|
|  |     |        | min   | max | Factory American     | Factory European     | Keyp.      | RS485/<br>BUS/<br>Opt2-M | Term. | Opt2-A/<br>PDC |
| Digital input 3<br>(Select like input 1)   | 139 | U16    | 0     | 87  | OFF (0)              | OFF (0)              | ✓          | R/Z                      | -     | -              |
| Digital input 4<br>(Select like input 1)   | 140 | U16    | 0     | 87  | OFF (0)              | OFF (0)              | ✓          | R/Z                      | -     | -              |
| Digital input 5<br>(Select like input 1)   | 141 | U16    | 0     | 87  | OFF (0)              | OFF (0)              | ✓          | R/Z                      | -     | -              |
| Digital input 6<br>(Select like input 1)   | 142 | U16    | 0     | 87  | OFF (0)              | OFF (0)              | ✓          | R/Z                      | -     | -              |
| Digital input 7<br>(Select like input 1)   | 143 | U16    | 0     | 87  | OFF (0)              | OFF (0)              | ✓          | R/Z                      | -     | -              |
| Digital input 8<br>(Select like input 1)   | 144 | U16    | 0     | 87  | OFF (0)              | OFF (0)              | ✓          | R/Z                      | -     | -              |
| Digital output 1                           | 145 | U16    | 0     | 77  | Ramp +<br>(8)        | Ramp +<br>(8)        | ✓          | R/Z                      | -     | -              |
| OFF  |     |        |       |     |                      |                      |            | 0                        |       |                |
| Speed zero thr                             |     |        |       |     |                      |                      |            | 1                        |       |                |
| Spd threshold                              |     |        |       |     |                      |                      |            | 2                        |       |                |
| Set speed                                  |     |        |       |     |                      |                      |            | 3                        |       |                |
| Curr limit state                           |     |        |       |     |                      |                      |            | 4                        |       |                |
| Drive ready                                |     |        |       |     |                      |                      |            | 5                        |       |                |
| Mot ovrlld avail                           |     |        |       |     |                      |                      |            | 6                        |       |                |
| Overload state                             |     |        |       |     |                      |                      |            | 7                        |       |                |
| Ramp +                                     |     |        |       |     |                      |                      |            | 8                        |       |                |
| Ramp -                                     |     |        |       |     |                      |                      |            | 9                        |       |                |
| Speed limited                              |     |        |       |     |                      |                      |            | 10                       |       |                |
| Undervoltage                               |     |        |       |     |                      |                      |            | 11                       |       |                |
| Overvoltage                                |     |        |       |     |                      |                      |            | 12                       |       |                |
| Heatsink                                   |     |        |       |     |                      |                      |            | 13                       |       |                |
| Overcurrent                                |     |        |       |     |                      |                      |            | 14                       |       |                |
| Overtemp motor                             |     |        |       |     |                      |                      |            | 15                       |       |                |
| External fault                             |     |        |       |     |                      |                      |            | 16                       |       |                |
| Failure supply                             |     |        |       |     |                      |                      |            | 17                       |       |                |
| Pad A bit                                  |     |        |       |     |                      |                      |            | 18                       |       |                |
| Pad B bit                                  |     |        |       |     |                      |                      |            | 19                       |       |                |
| Virt dig input                             |     |        |       |     |                      |                      |            | 20                       |       |                |
| Torque sign                                |     |        |       |     |                      |                      |            | 21                       |       |                |
| Stop control                               |     |        |       |     |                      |                      |            | 23                       |       |                |
| Field loss                                 |     |        |       |     |                      |                      |            | 24                       |       |                |
| Speed fbk loss                             |     |        |       |     |                      |                      |            | 25                       |       |                |
| Bus loss                                   |     |        |       |     |                      |                      |            | 26                       |       |                |
| Hw opt1 failure                            |     |        |       |     |                      |                      |            | 28                       |       |                |
| Opt2 failure                               |     |        |       |     |                      |                      |            | 29                       |       |                |
| Encoder 1 state                            |     |        |       |     |                      |                      |            | 30                       |       |                |
| Encoder 2 state                            |     |        |       |     |                      |                      |            | 31                       |       |                |
| Enable seq err                             |     |        |       |     |                      |                      |            | 35                       |       |                |
| Diameter calc st                           |     |        |       |     |                      |                      |            | 38                       |       |                |
| Drive healthy                              |     |        |       |     |                      |                      |            | 42                       |       |                |
| Input 1 cp match                           |     |        |       |     |                      |                      |            | 49                       |       |                |
| Diam reached                               |     |        |       |     |                      |                      |            | 58                       |       |                |
| Spd match compl                            |     |        |       |     |                      |                      |            | 59                       |       |                |
| Acc state                                  |     |        |       |     |                      |                      |            | 60                       |       |                |
| Dec state                                  |     |        |       |     |                      |                      |            | 61                       |       |                |
| Brake comand                               |     |        |       |     |                      |                      |            | 62                       |       |                |
| Brake failure                              |     |        |       |     |                      |                      |            | 63                       |       |                |
| Mot ovrlld preal                           |     |        |       |     |                      |                      |            | 65                       |       |                |
| Dvr ovrlld preal                           |     |        |       |     |                      |                      |            | 66                       |       |                |
| Dvr ovrlld avail                           |     |        |       |     |                      |                      |            | 67                       |       |                |
| I2t mot ovrlld fail                        |     |        |       |     |                      |                      |            | 68                       |       |                |
| I2t drv ovrlld fail                        |     |        |       |     |                      |                      |            | 69                       |       |                |
| Mot cur threshld                           |     |        |       |     |                      |                      |            | 70                       |       |                |
| Overspeed                                  |     |        |       |     |                      |                      |            | 71                       |       |                |
| Delta frequency                            |     |        |       |     |                      |                      |            | 72                       |       |                |
| Drv rdy to start                           |     |        |       |     |                      |                      |            | 76                       |       |                |
| BUS control mode                           |     |        |       |     |                      |                      |            | 77                       |       |                |
| Digital output 2<br>(Select like output 1) | 146 | U16    | 0     | 77  | Ramp -<br>(9)        | Ramp -<br>(9)        | ✓          | R/Z                      | -     | -              |
| Digital output 3<br>(Select like output 1) | 147 | U16    | 0     | 77  | Spd thr.<br>(2)      | Spd thr.<br>(2)      | ✓          | R/Z                      | -     | -              |
| Digital output 4<br>(Select like output 1) | 148 | U16    | 0     | 77  | Overld<br>avail. (6) | Overld<br>avail. (6) | ✓          | R/Z                      | -     | -              |

| Parameter  | No. | Format  | Value  |                  |                           |                           | Access via |                          |       |                |  |
|--|-----|---------|--------|------------------|---------------------------|---------------------------|------------|--------------------------|-------|----------------|--|
|  |     |         | min    | max              | Factory American          | Factory European          | Keyp.      | RS485/<br>BUS/<br>Opt2-M | Term. | Opt2-A/<br>PDC |  |
| Digital output 5<br>(Select like output 1)               | 149 | U16     | 0      | 77               | Curr lim.<br>state (4)    | Curr lim.<br>state (4)    | ✓          | R/Z                      | -     | -              |  |
| Digital output 6<br>(Select like output 1)               | 150 | U16     | 0      | 77               | Over-<br>voltage<br>(12)  | Over-<br>voltage<br>(12)  | ✓          | R/Z                      | -     | -              |  |
| Digital output 7<br>(Select like output 1)               | 151 | U16     | 0      | 77               | Under-<br>voltage<br>(11) | Under-<br>voltage<br>(11) | ✓          | R/Z                      | -     | -              |  |
| Digital output 8<br>(Select like output 1)               | 152 | U16     | 0      | 77               | Over-cur-<br>rent (14)    | Over-cur-<br>rent (14)    | ✓          | R/Z                      | -     | -              |  |
| Enab multi spd<br>Enabled<br>Disabled                    | 153 | I16     | 0      | 1                | Disabled                  | Disabled                  | ✓          | R/Z<br>1<br>0            | -     | -              |  |
| Multi speed 1 [FF]                                       | 154 | I16     | -32768 | +32767           | 0                         | 0                         | ✓          | R/W                      | -     | -              |  |
| Multi speed 2 [FF]                                       | 155 | I16     | -32768 | +32767           | 0                         | 0                         | ✓          | R/W                      | -     | -              |  |
| Multi speed 3 [FF]                                       | 156 | I16     | -32768 | +32767           | 0                         | 0                         | ✓          | R/W                      | -     | -              |  |
| Multi speed 4 [FF]                                       | 157 | I16     | -32768 | +32767           | 0                         | 0                         | ✓          | R/W                      | -     | -              |  |
| Multi speed 5 [FF]                                       | 158 | I16     | -32768 | +32767           | 0                         | 0                         | ✓          | R/W                      | -     | -              |  |
| Multi speed 6 [FF]                                       | 159 | I16     | -32768 | +32767           | 0                         | 0                         | ✓          | R/W                      | -     | -              |  |
| Multi speed 7 [FF]                                       | 160 | I16     | -32768 | +32767           | 0                         | 0                         | ✓          | R/W                      | -     | -              |  |
| Motor max speed [rpm]                                    | 162 | Float * | 0      | 6553             | 1500                      | 1500                      | ✓          | R/Z                      | -     | R              |  |
| Encoder 2 pulses   | 169 | Float * | 600    | 9999             | 1024                      | 1024                      | ✓          | R/Z                      | -     | R              |  |
| Max out voltage [V]                                      | 175 | Float   | 20     | 999              | 400                       | 400                       | ✓          | R/Z                      | -     | -              |  |
| Full load curr [A]                                       | 179 | Float   | 0.1    | I <sub>dAN</sub> | I <sub>dAN</sub>          | I <sub>dAN</sub>          | ✓          | R/Z                      | -     | -              |  |
| Enable spd adap<br>Enabled<br>Disabled                   | 181 | U16     | 0      | 1                | Disabled                  | Disabled                  | ✓          | R/Z<br>1<br>0            | -     | -              |  |
| Select adap type<br>Speed<br>Adap reference<br>Parameter | 182 | U16     | 0      | 2                | Speed                     | Speed                     | ✓          | R/Z<br>0<br>1<br>2       | -     | -              |  |
| Adap reference [FF]                                      | 183 | I16     | -32768 | +32767           | 1000                      | 1000                      | ✓          | R/W                      | IA    | R/W            |  |
| Adap speed 1 [%]   | 184 | Float   | 0.0    | 200.0            | 20.3                      | 20.3                      | ✓          | R/W                      | -     | -              |  |
| Adap speed 2 [%]   | 185 | Float   | 0.0    | 200.0            | 40.7                      | 40.7                      | ✓          | R/W                      | -     | -              |  |
| Adap joint 1 [%]   | 186 | Float   | 0.0    | 200.0            | 6.1                       | 6.1                       | ✓          | R/W                      | -     | -              |  |
| Adap joint 2 [%]   | 187 | Float   | 0.0    | 200.0            | 6.1                       | 6.1                       | ✓          | R/W                      | -     | -              |  |
| Adap P gain 1 [%]  | 188 | Float   | 0.00   | 100.00           | 10.00                     | 10.00                     | ✓          | R/W                      | -     | -              |  |
| Adap I gain 1 [%]  | 189 | Float   | 0.00   | 100.00           | 1.00                      | 1.00                      | ✓          | R/W                      | -     | -              |  |
| Adap P gain 2 [%]  | 190 | Float   | 0.00   | 100.00           | 10.00                     | 10.00                     | ✓          | R/W                      | -     | -              |  |
| Adap I gain 2 [%]  | 191 | Float   | 0.00   | 100.00           | 1.00                      | 1.00                      | ✓          | R/W                      | -     | -              |  |
| Adap P gain 3 [%]  | 192 | Float   | 0.00   | 100.00           | 10.00                     | 10.00                     | ✓          | R/W                      | -     | -              |  |
| Adap I gain 3 [%]  | 193 | Float   | 0.00   | 100.00           | 1.00                      | 1.00                      | ✓          | R/W                      | -     | -              |  |
| Latch<br>ON<br>OFF                                       | 194 | U16     | 0      | 1                | ON                        | ON                        | ✓          | R/Z<br>1<br>0            | -     | -              |  |
| Ok relay open<br>ON<br>OFF                               | 195 | I16     | 0      | 1                | ON                        | ON                        | ✓          | R/W<br>1<br>0            | -     | -              |  |
| Motor current [%]  | 199 | I16     | -250   | 250              | -                         | -                         | ✓          | R                        | QA    | R              |  |
| 2B + E<br>ON (Off)<br>OFF (On)                           | 201 | U16     | 0      | 1                | 0                         | 0                         | ✓          | R/Z<br>0<br>1            | -     | -              |  |
| Ramp selector  | 202 | U16     | 0      | 3                | 0                         | 0                         | ✓          | R/W                      | ID    | R/W            |  |
| Activity<br>Ignore<br>Warning<br>Disable drive           | 203 | U16     | 0      | 2                | Ignore                    | Ignore                    | ✓          | R/Z<br>0<br>1<br>2       | -     | -              |  |
| Multispeed sel   | 208 | U16     | 0      | 7                | 0                         | 0                         | ✓          | R/W                      | ID    | R/W            |  |

| Parameter                                      | No. | Format   | Value |                   |                  |                  | Access via |                          |              |                |
|--|-----|----------|-------|-------------------|------------------|------------------|------------|--------------------------|--------------|----------------|
|  |     |          | min   | max               | Factory American | Factory European | Keyp.      | RS485/<br>BUS/<br>Opt2-M | Term.        | Opt2-A/<br>PDC |
| Activity<br>Ignore<br>Warning<br>Disable drive | 212 | U16      | 0     | 2                 | Ignore           | Ignore           | ✓          | R/Z<br>0<br>1<br>2       | -            | -              |
| Output voltage [V]                             | 233 | Float ** | 0     | 999               | -                | -                | ✓          | R                        | QA           | R              |
| “Flux current [%]                              | 234 | Float *  | 0.0   | 100.0             | -                | -                | ✓          | R                        | QA           | R              |
| Life time [h.min]                              | 235 | Float    | 0.00  | 65535.00          |                  |                  | ✓          | R                        | -            | -              |
| Speed reg output [% ]                          | 236 | I16      | -200  | +200<br>see 6.7.1 | -                | -                | ✓          | R                        | QA           | R              |
| Enable spd reg<br>Enable<br>Disable            | 242 | I16      | 0     | 1                 | Enabled          | Enabled          | ✓          | R/Z<br>1<br>0            | -            | -              |
| Enab multi rmp<br>Enabled<br>Disabled          | 243 | I16      | 0     | 1                 | Disabled         | Disabled         | ✓          | R/Z<br>1<br>0            | -            | -              |
| Enable jog<br>Enabled<br>Disabled              | 244 | I16      | 0     | 1                 | Disabled         | Disabled         | ✓          | R/Z<br>1<br>0            | -            | -              |
| Enable ramp<br>Enabled<br>Disabled             | 245 | I16      | 0     | 1                 | Enabled<br>(1)   | Enabled<br>(1)   | ✓          | R/Z<br><br>1<br>0        | -            | -              |
| Enable motor pot<br>Enabled<br>Disabled        | 246 | I16      | 0     | 1                 | Disabled         | Disabled         | ✓          | R/Z<br>1<br>0            | -            | -              |
| Motor pot oper                                 | 247 |          |       |                   |                  |                  | ✓          | -                        | -            | -              |
| Motor pot sign<br>Positive<br>Negative         | 248 | I16      | 0     | 1                 | Positive         | Positive         | ✓          | R/W<br>1<br>0            | ID           | -              |
| Motor pot reset                                | 249 | U16      |       |                   |                  |                  | ✓          | Z/C(1)                   | ID (H)       | -              |
| Main commands<br>Terminals<br>Digitals         | 252 | U16      | 0     | 1                 | Term (0)         | Term (0)         | ✓          | R/Z<br>0<br>1            | -            | -              |
| Control mode<br>Local<br>Bus                   | 253 | U16      | 0     | 1                 | Local (0)        | Local (0)        | ✓          | R/Z<br>0<br>1            | -            | -              |
| Save parameters                                | 256 | U16      |       |                   |                  |                  | ✓          | C/W<br>(1)               | -            | -              |
| Load default                                   | 258 | U16      |       |                   |                  |                  | ✓          | Z/C(1)                   | -            | -              |
| Auto tune inp 1<br>Auto tune                   | 259 | U16      |       |                   |                  |                  | ✓          | C/W<br>1                 | -            | -              |
| Auto tune inp 2<br>Auto tune                   | 260 | U16      |       |                   |                  |                  | ✓          | C/W<br>1                 | -            | -              |
| Auto tune inp 3<br>Auto tune                   | 261 | U16      |       |                   |                  |                  | ✓          | C/W<br>1                 | -            | -              |
| Failure reset                                  | 262 | U16      |       |                   |                  |                  | ✓          | Z/C (1)                  | ID (H)       | W              |
| Failure reg del                                | 263 | U16      |       |                   |                  |                  | ✓          | C                        | -            | -              |
| Jog operation                                  | 265 | -        | -     | -                 | -                | -                | ✓          | -                        | -            | -              |
| Jog reference [FF]                             | 266 | I16      | 0     | 32767             | 0                | 0                | ✓          | R/W                      | IA           | -              |
| Motor nom flux                                 | 280 | Float    | 0.0   | P374              | P374             | P374             | ✓          | R/Z                      | -            | -              |
| Forward sign                                   | 293 | U16      | 0     | 1                 | 0                | 0                | -          | R/W                      | ID           | R/W            |
| Reverse sign                                   | 294 | U16      | 0     | 1                 | 0                | 0                | -          | R/W                      | ID           | R/W            |
| An in 1 target<br>Assigned<br>Not assigned     | 295 | U16      | 0     | 1                 | 0                | 0                | ✓          | R/W<br>0<br>1            | ID<br>L<br>H | R/W<br>0<br>1  |
| An in 2 target<br>Assigned<br>Not assigned     | 296 | U16      | 0     | 1                 | 0                | 0                | ✓          | R/W<br>0<br>1            | ID<br>L<br>H | R/W<br>0<br>1  |
| An in 3 target<br>Assigned<br>Not assigned     | 297 | U16      | 0     | 1                 | 0                | 0                | ✓          | R/W<br>0<br>1            | ID<br>L<br>H | R/W<br>0<br>1  |

| Parameter  | No. | Format | Value |               |                   |                   | Access via |                              |              |                |
|--|-----|--------|-------|---------------|-------------------|-------------------|------------|------------------------------|--------------|----------------|
|  |     |        | min   | max           | Factory American  | Factory European  | Keyp.      | RS485/<br>BUS/<br>Opt2-M     | Term.        | Opt2-A/<br>PDC |
| Drive type<br>TPD32-...-2B<br>TPD32-...-4B   | 300 | U16    | 10    | 11            | S                 | S                 | -          | R<br>10<br>11                | -            | R<br>10<br>11  |
| Enable overload<br>Enabled<br>Disabled   | 309 | I16    | 0     | 1             | Enabled           | Disabled          | ✓          | R/Z<br>1<br>0                | -            | -              |
| Overload time [s]  | 310 | U16    | 0     | 65535         | 60                | 30                | ✓          | R/W                          | -            | -              |
| Pause time [s]   | 311 | U16    | 0     | 65535         | 540               | 300               | ✓          | R/W                          | -            | -              |
| Overload current [%]   | 312 | U16    | P313  | 200           | 150               | 100               | ✓          | R/W                          | -            | -              |
| Base current [%]   | 313 | U16    | 0     | P312<br>< 100 | 100               | 80                | ✓          | R/W                          | -            | -              |
| Enable drive<br>Enabled<br>Disabled  | 314 | U16    | 0     | 1             | Disabled          | Disabled          | ✓          | R/W<br>1<br>0                | 12<br>H<br>L | R/W<br>1<br>0  |
| Start/Stop<br>Start<br>Stop  | 315 | U16    | 0     | 1             | Stop<br>(0)       | Stop<br>(0)       |            | R/W<br>1<br>0                | 13<br>H<br>L | R/W<br>1<br>0  |
| Fast stop<br>Fast Stop<br>No Fast Stop   | 316 | U16    | 0     | 1             | No Fast<br>Stop   | No Fast<br>Stop   | -          | R/W<br>0<br>1                | 14<br>L<br>H | R/W<br>0<br>1  |
| Overload mode<br>Curr limited<br>Curr not limited<br>I2t Motor<br>I2t Drive<br>I2t Motor & Drv | 318 | U16    | 0     | 4             | I2t Motor         | Curr<br>limited   | ✓          | R/W<br>0<br>1<br>2<br>3<br>4 | -            | -              |
| Device address   | 319 | U16    | 0     | 127           | 0                 | 0                 | ✓          | R/Z                          | -            | -              |
| Lock speed reg<br>ON<br>OFF  | 322 | U16    | 0     | 1             | OFF               | OFF               | ✓          | R/W<br>1<br>0                | ID<br>L<br>H | R/W<br>1<br>0  |
| Ser protocol sel<br>SLINK3<br>MODBUS RTU<br>JBUS   | 323 | U16    | 0     | 2             | SLINK3<br>(0)     | SLINK3<br>(0)     | ✓          | R/W<br>0<br>1<br>2           | --           | ---            |
| Ser baudrate sel<br>19200<br>9600<br>4800<br>2400<br>1200                                      | 326 | U16    | 0     | 4             | 9600<br>(1)       | 9600<br>(1)       | ✓          | R/W<br>0<br>1<br>2<br>3<br>4 | --           | ---            |
| Failure text   | 327 | Text   |       |               |                   |                   | -          | R                            | -            | -              |
| Failure hour   | 328 | U16    | 0     | 65535         |                   |                   |            | R                            | -            | -              |
| Failure minute   | 329 | U16    | 0     | 59            |                   |                   |            | R                            | -            | -              |
| Failure register   | 330 | U16    | 1     | 10            | 10                | 10                | ✓          | R/W                          | -            | -              |
| Software version   | 331 | Text   |       |               |                   |                   | ✓          | R                            | -            | -              |
| Torque reduct<br>Not active<br>Active  | 342 | U16    | 0     | 1             | Not active<br>(0) | Not active<br>(0) | ✓          | R/W<br>0<br>1                | ID<br>L<br>H | R/W<br>0<br>1  |
| Quick stop<br>Quick stop<br>No Quick stop  | 343 | U16    | 0     | 1             | No Quick<br>stop  | No Quick<br>stop  | -          | R/W<br>0<br>1                | -            | -              |
| Ramp out = 0<br>Active<br>Not active   | 344 | U16    | 0     | 1             | Not active<br>(1) | Not active<br>(1) | ✓          | R/W<br>0<br>1                | ID<br>L<br>H | R/W<br>0<br>1  |
| Ramp in = 0<br>Active<br>Not active  | 345 | U16    | 0     | 1             | Not active<br>(1) | Not active<br>(1) | ✓          | R/W<br>0<br>1                | ID<br>L<br>H | R/W            |

| Parameter  | No. | Format | Value |       |                   |                   | Access via |                                       |                  |                   |
|--|-----|--------|-------|-------|-------------------|-------------------|------------|---------------------------------------|------------------|-------------------|
|  |     |        | min   | max   | Factory American  | Factory European  | Keyp.      | RS485/<br>BUS/<br>Opt2-M              | Term.            | Opt2-A/<br>PDC    |
| Ramp +<br>Acc.CW + Dec. anti-CW<br>Other states  | 346 | U16    | 0     | 1     | -                 | -                 | -          | R<br>1<br>0                           | QD<br>H<br>L     | R<br>1<br>0       |
| Ramp -<br>Acc.anti-CW + Dec. CW<br>Other states  | 347 | U16    | 0     | 1     | -                 | -                 | -          | R<br>1<br>0                           | QD<br>H<br>L     | R<br>1<br>0       |
| Lock speed I<br><br>Active<br>Not active   | 348 | U16    | 0     | 1     | Not active<br>(1) | Not active<br>(1) | ✓          | R/W<br><br>0<br>1                     | ID<br><br>L<br>H | R/W<br><br>0<br>1 |
| Curr limit state<br>Curr. limit not reached<br>Curr. limit reached                               | 349 | U16    | 0     | 1     |                   |                   | -          | R<br>0<br>1                           | QD<br>L<br>H     | R<br>0<br>1       |
| Flux current (A)   | 351 | Float  | 0.1   | 99.9  | S                 | S                 | ✓          | R                                     | -                | -                 |
| Zero torque<br><br>Active<br>Not active  | 353 | U16    | 0     | 1     | Not active<br>(1) | Not active<br>(1) | ✓          | R/W<br>0<br>1                         | ID<br>L<br>H     | R/W               |
| Activity<br><br>Warning<br>Disable drive<br>Quick stop<br>Normal stop<br>Curr lim stop           | 354 | U16    | 1     | 5     | Disable drive     | Disable drive     | ✓          | R/Z<br><br>1<br>2<br>3<br>4<br>5      | -                | -                 |
| Latch<br><br>ON<br>OFF   | 355 | U16    | 0     | 1     | ON                | ON                | ✓          | R/Z<br>1<br>0                         | -                | -                 |
| Ok relay open<br><br>ON<br>OFF   | 356 | I16    | 0     | 1     | ON                | ON                | ✓          | R/W<br>1<br>0                         | -                | -                 |
| Latch<br><br>ON<br>OFF   | 357 | U16    | 0     | 1     | ON                | ON                | ✓          | R/Z<br>1<br>0                         | -                | -                 |
| Ok relay open<br><br>ON<br>OFF   | 358 | I16    | 0     | 1     | ON                | ON                | ✓          | R/W<br>1<br>0                         | -                | -                 |
| Restart time [ms]  | 359 | U16    | 0     | 65535 | 1000              | 1000              | ✓          | R/W                                   | -                | -                 |
| Latch<br><br>ON<br>OFF   | 361 | U16    | 0     | 1     | ON                | ON                | ✓          | R/Z<br>1<br>0                         | -                | -                 |
| Ok relay open<br><br>ON<br>OFF   | 362 | I16    | 0     | 1     | ON                | ON                | ✓          | R/W<br>1<br>0                         | -                | -                 |
| Latch<br><br>ON<br>OFF   | 363 | U16    | 0     | 1     | ON                | ON                | ✓          | R/Z<br>1<br>0                         | -                | -                 |
| Ok relay open<br><br>ON<br>OFF   | 364 | I16    | 0     | 1     | ON                | ON                | ✓          | R/W<br>1<br>0                         | -                | -                 |
| Activity<br><br>Ignore<br>Warning<br>Disable drive<br>Quick stop<br>Normal stop<br>Curr lim stop | 365 | U16    |       |       | Disable drive     | Disable drive     | ✓          | R/Z<br><br>0<br>1<br>2<br>3<br>4<br>5 | -                | -                 |
| Ok relay open<br><br>ON<br>OFF   | 367 | I16    |       |       | ON                | ON                | ✓          | R/W<br>1<br>0                         | -                | -                 |
| Activity<br><br>Warning<br>Disable drive<br>Quick stop<br>Normal stop<br>Curr lim stop           | 368 | U16    | 1     | 5     | Disable drive     | Disable drive     | ✓          | R/Z<br><br>1<br>2<br>3<br>4<br>5      | -                | -                 |

| Parameter  | No. | Format | Value  |        |                   |                   | Access via |                              |              |                |  |
|--|-----|--------|--------|--------|-------------------|-------------------|------------|------------------------------|--------------|----------------|--|
|  |     |        | min    | max    | Factory American  | Factory European  | Keyp.      | RS485/<br>BUS/<br>Opt2-M     | Term.        | Opt2-A/<br>PDC |  |
| Ok relay open<br>ON<br>OFF   | 370 | I16    | 0      | 1      | ON                | ON                | ✓          | R/W<br>1<br>0                | -            | -              |  |
| Speed limited<br>Speed not limited<br>Speed limited                                | 372 | U16    | 0      | 1      |                   |                   | -          | R<br>0<br>1                  | QD<br>L<br>H | R<br>0<br>1    |  |
| Freeze ramp<br>Active<br>Not active  | 373 | U16    | 0      | 1      | Not active<br>(1) | Not active<br>(1) | ✓          | R/W<br>0<br>1                | ID<br>H<br>L | R/W<br>1<br>0  |  |
| Nom flux curr [A]  | 374 | Float  | 0.5    | 70.0   | S                 | S                 | ✓          | R/Z                          | -            | -              |  |
| Jog selection<br>Speed input<br>Ramp input   | 375 | U16    | 0      | 1      | 0                 | 0                 | ✓          | R/Z<br>0<br>1                | -            | -              |  |
| Speed ref 1 (%)  | 378 | Float  | -200.0 | +200.0 | 0                 | 0                 | ✓          | R/W                          | -            | -              |  |
| Speed Ref 2 (%)  | 379 | Float  | -200.0 | +200.0 | 0                 | 0                 | ✓          | R/W                          | -            | -              |  |
| Drive ready<br>Drive ready<br>Drive not ready                                      | 380 | U16    | 0      | 1      | -                 | -                 | -          | R<br>1<br>0                  | QD<br>H<br>L | R<br>1<br>0    |  |
| Activity<br>Warning<br>Disable drive<br>Quick stop<br>Normal stop<br>Curr lim stop | 386 | U16    | 1      | 5      | Disable<br>drive  | Disable<br>drive  | ✓          | R/Z<br>1<br>2<br>3<br>4<br>5 | -            | -              |  |
| Ok relay open<br>ON<br>OFF   | 387 | I16    | 0      | 1      | ON                | ON                | ✓          | R/W<br>1<br>0                | -            | -              |  |
| Auto capture<br>ON<br>OFF  | 388 | U16    |        |        | OFF<br>(0)        | OFF<br>(0)        | ✓          | R/W<br>1<br>0                | ID<br>H<br>L | -              |  |
| Input 1 sign<br>Positive<br>Negative   | 389 | U16    | 0      | 1      | 1                 | 1                 | ✓          | R/W<br>1<br>0                | -            | R/W<br>1<br>0  |  |
| Input 2 sign<br>Positive<br>Negative   | 390 | U16    | 0      | 1      | 1                 | 1                 | ✓          | R/W<br>1<br>0                | -            | R/W<br>1<br>0  |  |
| Input 3 sign<br>Positive<br>Negative   | 391 | U16    | 0      | 1      | 1                 | 1                 | ✓          | R/W<br>1<br>0                | -            | R/W<br>1<br>0  |  |
| Spd threshold<br>Speed exceeded<br>Speed not exceeded                              | 393 | U16    | 0      | 1      |                   |                   | -          | R<br>0<br>1                  | QD<br>L<br>H | R<br>0<br>1    |  |
| Set speed<br>Speed not ref. val.<br>Speed = ref. val.                              | 394 | U16    | 0      | 1      |                   |                   | -          | R<br>0<br>1                  | QD<br>L<br>H | R<br>0<br>1    |  |
| Speed zero thr<br>Drive not rotating<br>Drive rotating                             | 395 | U16    | 0      | 1      |                   |                   | -          | R<br>0<br>1                  | QD<br>L<br>H | R<br>0<br>1    |  |
| Motor pot up<br>No acceleration<br>Acceleration                                    | 396 | U16    | 0      | 1      |                   |                   |            | R/W<br>0<br>1                | ID<br>L<br>H | R/W<br>0<br>1  |  |
| Motor pot down<br>No deceleration<br>Deceleration                                  | 397 | U16    | 0      | 1      |                   |                   |            | R/W<br>0<br>1                | ID<br>L<br>H | R/W<br>0<br>1  |  |
| Jog +<br>No jog forwards<br>Forwards jog   | 398 | U16    | 0      | 1      |                   |                   |            | R/W<br>0<br>1                | ID<br>L<br>H | R/W<br>0<br>1  |  |
| Jog -<br>No backwards jog<br>Backwards jog   | 399 | U16    | 0      | 1      |                   |                   |            | R/W<br>0<br>1                | ID<br>L<br>H | R/W<br>0<br>1  |  |
| Speed sel 0<br>Value 2 <sup>0</sup> not selected<br>Value 2 <sup>0</sup> selected  | 400 | U16    | 0      | 1      | 0                 | 0                 | -          | R/W<br>0<br>1                | ID<br>L<br>H | R/W<br>0<br>1  |  |



| Parameter  | No. | Format  | Value  |        |                  |                  | Access via |  |              |                |
|--|-----|---------|--------|--------|------------------|------------------|------------|--|--------------|----------------|
|  |     |         | min    | max    | Factory American | Factory European | Keyp.      | RS485/<br>BUS/<br>Opt2-M   | Term.        | Opt2-A/<br>PDC |
| Speed sel 1<br>Value 2 <sup>1</sup> not selected<br>Value 2 <sup>1</sup> selected  | 401 | U16     | 0      | 1      | 0                | 0                | -          | R/W<br>0<br>1  | ID<br>L<br>H | R/W<br>0<br>1  |
| Speed sel 2<br>Value 2 <sup>2</sup> not selected<br>Value 2 <sup>2</sup> selected  | 402 | U16     | 0      | 1      | 0                | 0                | -          | R/W<br>0<br>1  | ID<br>L<br>H | R/W<br>0<br>1  |
| Ramp sel 0<br>Value 2 <sup>0</sup> not selected<br>Value 2 <sup>0</sup> selected   | 403 | U16     | 0      | 1      |                  |                  | -          | R/W<br>0<br>1  | ID<br>L<br>H | R/W<br>0<br>1  |
| Ramp sel 1<br>Value 2 <sup>1</sup> not selected<br>Value 2 <sup>1</sup> selected   | 404 | U16     | 0      | 1      |                  |                  | -          | R/W<br>0<br>1  | ID<br>L<br>H | R/W<br>0<br>1  |
| Overld available<br>Overload not possible<br>Overload possible   | 406 | U16     | 0      | 1      | -                | -                | -          | R<br>0<br>1  | QD<br>L<br>H | R<br>0<br>1    |
| Overload state<br>Current limit value<br>Current > limit value   | 407 | U16     | 0      | 1      | -                | -                | -          | R<br>0<br>1  | QD<br>L<br>H | R<br>0<br>1    |
| Ser answer delay   | 408 | U16     | 0      | 900    | 0                | 0                | ✓          | R/W  | --           | ---            |
| Ok relay funct<br>Drive healthy<br>Ready to Start  | 412 | I16     | 0      | 1      | 0                | 0                | ✓          | R/Z<br>0<br>1  | -            | -              |
| Speed fbk sel<br>Encoder 1<br>Encoder 2<br>Tacho<br>Armature   | 414 | U16     | 0      | 3      | 1                | 1                | ✓          | R/Z<br>0<br>1<br>2<br>3  | -            | R              |
| Encoder 1 pulses   | 416 | Float * | 600    | 9999   | 1024             | 1024             | ✓          | R/Z  | -            | R              |
| Failure code<br>Failure supply<br>Undervoltage<br>Overvoltage<br>Overcurrent<br>Heatsink<br>Hardware<br>DSP error<br>Interrupt error<br>Speed fbk<br>External fault<br>Overtemp motor<br>Field loss<br>Bus loss<br>Hw opt 1 failure<br>Opt2<br>Unknown<br>Enable seq err | 417 | U16     | 0      | 65535  |                  |                  |            | R<br>5100h<br>3120h<br>3310h<br>2300h<br>4210h<br>5000h<br>6110h<br>6120h<br>7301h<br>9000h<br>4310h<br>3330h<br>8110h<br>7510h<br>7400h<br>1001h<br>9009h | -            | -              |
| Real FF PID  | 418 | I16     | -10000 | +10000 | 0                | 0                | ✓          | R/W  | -            | R              |
| Enc 2 speed (rpm)  | 420 | I16     | -8192  | +8192  | -                | -                | ✓          | R  |              | R              |
| PD output PID  | 421 | I16     | -10000 | +10000 | 0                | 0                | ✓          | R  | -            | -              |
| Enable OPT2<br>Enabled<br>Disabled   | 425 | U16     | 0      | 1      | Disable          | Disable          | ✓          | R/Z<br>1<br>0  | -            | -              |
| Enc 1 speed (rpm)  | 427 | I16     | -8192  | +8192  | -                | -                | ✓          | R  |              | R              |
| Prop filter [ms]   | 444 | U16     | 0      | 1000   | 0                | 0                | ✓          | R/W  | -            | -              |
| Speed up gain [%]  | 445 | Float   | 0.00   | 100.00 | 0.00             | 0.00             | ✓          | R/W  | -            | -              |
| Speed up base [ms]   | 446 | Float   | 0      | 16000  | 1000             | 1000             | ✓          | R/W  | -            | -              |
| Speed up filter [ms]   | 447 | U16     | 0      | 1000   | 0                | 0                | ✓          | R/W  | -            | -              |
| R&L Search<br>OFF<br>ON  | 452 | U16     | 0      | 1      | OFF              | OFF              | ✓          | R/Z<br>0<br>1  | -            | -              |
| Arm resistance [ ]   | 453 | Float   | S      | S      | 0.500            | 0.500            | ✓          | R/W  | -            | -              |
| Arm inductance [mH]  | 454 | Float   | S      | S      | 4.00             | 4.00             | ✓          | R/W  | -            | -              |
| Speed fbk error [%]  | 455 | U16     | 0      | 100    | 22               | 22               | ✓          | R/Z  | -            | -              |
| Flux weak speed [%]  | 456 | U16     | 0      | 100    | 100              | 100              | ✓          | R/Z  | -            | R              |

| Parameter  | No. | Format | Value            |                    |                        |                        | Access via |                          |              |                |  |
|--|-----|--------|------------------|--------------------|------------------------|------------------------|------------|--------------------------|--------------|----------------|--|
|  |     |        | min              | max                | Factory American       | Factory European       | Keyp.      | RS485/<br>BUS/<br>Opt2-M | Term.        | Opt2-A/<br>PDC |  |
| Enable fbk contr<br>Enabled<br>Disabled  | 457 | U16    | 0                | 1                  | Enabled<br>(1)         | Enabled<br>(1)         | ✓          | R/Z<br>1<br>0            | -            | -              |  |
| Enable fbk bypas<br>Enabled<br>Disabled  | 458 | U16    | 0                | 1                  | 0                      | 0                      | ✓          | R/Z<br>1<br>0            | -            | -              |  |
| Speed P bypass [%]   | 459 | Float  | 0.00             | 100.00             | 10.00                  | 10.00                  | ✓          | R/W                      | -            | -              |  |
| Speed I bypass [%]   | 460 | Float  | 0.00             | 100.00             | 1.00                   | 1.00                   | ✓          | R/W                      | -            | -              |  |
| Size selection<br>Standard<br>American   | 464 | U16    | 0                | 1                  | 1                      | 1                      | ✓          | R/Z<br>0<br>1            | -            | -              |  |
| Drive size [A]   | 465 | U16    | 0                | S                  | S                      | S                      | ✓          | R                        | -            | R              |  |
| Mains voltage [V]  | 466 | U16    | 0                | 999                | -                      | -                      | ✓          | R                        | -            | -              |  |
| Flux current max [%]   | 467 | U16    | P468             | 100                | 100                    | 100                    | ✓          | R/W                      | -            | R/W            |  |
| Flux current min [%]   | 468 | U16    | 0                | P467               | 5                      | 5                      | ✓          | R/W                      | -            | ----           |  |
| Flux reg mode<br>Constant current<br>Voltage control<br>External control (OFF) | 469 | U16    | 0                | 2                  | Const.<br>current<br>0 | Const.<br>current<br>0 | ✓          | R/Z<br>0<br>1<br>2       | -            | -              |  |
| Hold off time [ms]   | 470 | U16    | 0                | 100                | 0                      | 0                      | ✓          | R/W                      | -            | -              |  |
| Latch<br>ON<br>OFF   | 471 | U16    | 0                | 1                  | ON                     | ON                     | ✓          | R/Z<br>1<br>0            | -            | -              |  |
| Ok relay open<br>ON<br>OFF   | 472 | I16    | 0                | 1                  | ON                     | ON                     | ✓          | R/W<br>1<br>0            | -            | -              |  |
| Activity<br>Ignore<br>Warning<br>Disable drive                                 | 473 | U16    | 0                | 2                  | Disable<br>drive       | Disable<br>drive       | ✓          | R/Z<br>0<br>1<br>2       | -            | -              |  |
| Restart time [ms]  | 474 | U16    | 0                | 10000              | 0                      | 0                      | ✓          | R/W                      | -            | -              |  |
| Hold off time [ms]   | 475 | U16    | 0                | 10000              | 0                      | 0                      | ✓          | R/W                      | -            | -              |  |
| Ok relay open<br>ON<br>OFF   | 477 | I16    | 0                | 1                  | ON                     | ON                     | ✓          | R/W<br>1<br>0            | -            | -              |  |
| Activity<br>Warning<br>Disable drive   | 478 | U16    | 1                | 2                  | Disable<br>drive       | Disable<br>drive       | ✓          | R/Z<br>1<br>2            | -            | -              |  |
| Hold off time [ms]   | 480 | U16    | 0                | 10000              | 8                      | 8                      | ✓          | R/W                      | -            | -              |  |
| Undervolt thr [V]  | 481 | U16    | 0                | 1000               | 230                    | 230                    | ✓          | R/W                      | -            | -              |  |
| Hold off time [ms]   | 482 | U16    | 0                | 10000              | 0                      | 0                      | ✓          | R/W                      | -            | -              |  |
| Restart time [ms]  | 483 | U16    | 0                | 10000              | 0                      | 0                      | ✓          | R/W                      | -            | -              |  |
| Source   | 484 | U16    | 0                | 65535              | 0                      | 0                      | ✓          | R/W                      | -            | -              |  |
| Destination  | 485 | U16    | 0                | 65535              | 0                      | 0                      | ✓          | R/W                      | -            | -              |  |
| Mul gain   | 486 | Float  | -10000           | +10000             | 1                      | 1                      | ✓          | R/W                      | -            | -              |  |
| Div gain   | 487 | Float  | -10000           | +10000             | 1                      | 1                      | ✓          | R/W                      | -            | -              |  |
| Input max  | 488 | Float  | -2 <sup>31</sup> | 2 <sup>31</sup> -1 | 0                      | 0                      | ✓          | R/W                      | -            | -              |  |
| Input min  | 489 | Float  | -2 <sup>31</sup> | 2 <sup>31</sup> -1 | 0                      | 0                      | ✓          | R/W                      | -            | -              |  |
| Input offset   | 490 | Float  | -2 <sup>31</sup> | 2 <sup>31</sup> -1 | 0                      | 0                      | ✓          | R/W                      | -            | -              |  |
| Output offset  | 491 | Float  | -2 <sup>31</sup> | 2 <sup>31</sup> -1 | 0                      | 0                      | ✓          | R/W                      | -            | -              |  |
| Inp absolute<br>OFF<br>ON  | 492 | U16    | 0                | 1                  | OFF                    | OFF                    | ✓          | R/W<br>0<br>1            | -            | -              |  |
| Voltage P [%]  | 493 | Float  | 0.00             | 100.00             | 30.00                  | 30.00                  | ✓          | R/W                      | -            | -              |  |
| Voltage I [%]  | 494 | Float  | 0.00             | 100.00             | 40.00                  | 40.00                  | ✓          | R/W                      | -            | -              |  |
| Voltage P base [f%/V]  | 495 | Float  | 0.0100           | S                  | S                      | S                      | ✓          | R/Z                      | -            | -              |  |
| Voltage I base [f%/V.ms]   | 496 | Float  | 0.01             | S                  | S                      | S                      | ✓          | R/Z                      | -            | -              |  |
| Enable flux reg<br>ON (Enabled)<br>OFF (Disabled)                              | 497 | U16    | 0                | 1                  | Enabled                | Enabled                | ✓          | R/W<br>1<br>0            | ID<br>H<br>L | -              |  |

| Parameter  | No. | Format | Value  |        |                  |                  | Access via |                          |              |                |
|--|-----|--------|--------|--------|------------------|------------------|------------|--------------------------|--------------|----------------|
|  |     |        | min    | max    | Factory American | Factory European | Keyp.      | RS485/<br>BUS/<br>Opt2-M | Term.        | Opt2-A/<br>PDC |
| Enable flux weak<br>ON (Enabled)<br>OFF (Disabled) | 498 | U16    | 0      | 1      | 1                | 1                | ✓          | R/W<br>1<br>0            | ID<br>H<br>L | -              |
| Speed-0 f weak<br>Enabled<br>Disabled              | 499 | U16    | 0      | 1      | 0                | 0                | ✓          | R/W<br>1<br>0            | -            | -              |
| Flux reference [%]                                 | 500 | Float* | 0.0    | 100.0  | -                | -                | ✓          | R                        | QA           | -              |
| Flux reference [%]                                 | 500 | Float* | 0.0    | 100.0  | 0.0              | 0.0              | ✓          | R                        | QA           | -              |
| Restart time [ms]                                  | 501 | U16    | 0      | 10000  | 0                | 0                | ✓          | R/W                      | -            | -              |
| Hold off time [ms]                                 | 502 | U16    | 0      | 10000  | 0                | 0                | ✓          | R/W                      | -            | -              |
| Pad 0  | 503 | I16    | -32768 | +32767 | 0                | 0                | ✓          | R/W                      | IA, QA       | R/W            |
| Pad 1  | 504 | I16    | -32768 | +32767 | 0                | 0                | ✓          | R/W                      | IA, QA       | R/W            |
| Pad 2  | 505 | I16    | -32768 | +32767 | 0                | 0                | ✓          | R/W                      | IA           | R/W            |
| Pad 3  | 506 | I16    | -32768 | +32767 | 0                | 0                | ✓          | R/W                      | IA           | R/W            |
| Pad 4  | 507 | I16    | -32768 | +32767 | 0                | 0                | ✓          | R/W                      | QA           | R/W            |
| Pad 5  | 508 | I16    | -32768 | +32767 | 0                | 0                | ✓          | R/W                      | QA           | R/W            |
| Pad 6  | 509 | I16    | -32768 | +32767 | 0                | 0                | ✓          | R/W                      | QA           | R/W            |
| Pad 7  | 510 | I16    | -32768 | +32767 | 0                | 0                | ✓          | R/W                      | -            | R/W            |
| Pad 8  | 511 | I16    | -32768 | +32767 | 0                | 0                | ✓          | R/W                      | -            | R/W            |
| Pad 9  | 512 | I16    | -32768 | +32767 | 0                | 0                | ✓          | R/W                      | -            | R/W            |
| Pad 10   | 513 | I16    | -32768 | +32767 | 0                | 0                | ✓          | R/W                      | -            | R/W            |
| Pad 11   | 514 | I16    | -32768 | +32767 | 0                | 0                | ✓          | R/W                      | -            | R/W            |
| Pad 12   | 515 | I16    | -32768 | +32767 | 0                | 0                | ✓          | R/W                      | -            | R/W            |
| Pad 13   | 516 | I16    | -32768 | +32767 | 0                | 0                | ✓          | R/W                      | -            | R/W            |
| Pad 14   | 517 | I16    | -32768 | +32767 | 0                | 0                | ✓          | R/W                      | -            | R/W            |
| Pad 15   | 518 | I16    | -32768 | +32767 | 0                | 0                | ✓          | R/W                      | -            | R/W            |
| Bitword pad A                                      | 519 | U16    | 0      | 65535  | 0                | 0                | ✓          | R/W                      | ID*,<br>QD*  | R/W            |
| Pad A Bit 0  | 520 | U16    | 0      | 1      | 0                | 0                | -          | R/W                      | ID, QD       | R/W            |
| Pad A Bit 1  | 521 | U16    | 0      | 1      | 0                | 0                | -          | R/W                      | ID, QD       | R/W            |
| Pad A Bit 2  | 522 | U16    | 0      | 1      | 0                | 0                | -          | R/W                      | ID, QD       | R/W            |
| Pad A Bit 3  | 523 | U16    | 0      | 1      | 0                | 0                | -          | R/W                      | ID, QD       | R/W            |
| Pad A Bit 4  | 524 | U16    | 0      | 1      | 0                | 0                | -          | R/W                      | ID, QD       | R/W            |
| Pad A Bit 5  | 525 | U16    | 0      | 1      | 0                | 0                | -          | R/W                      | ID, QD       | R/W            |
| Pad A Bit 6  | 526 | U16    | 0      | 1      | 0                | 0                | -          | R/W                      | ID, QD       | R/W            |
| Pad A Bit 7  | 527 | U16    | 0      | 1      | 0                | 0                | -          | R/W                      | ID, QD       | R/W            |
| Pad A Bit 8  | 528 | U16    | 0      | 1      | 0                | 0                | -          | R/W                      | QD*          | -              |
| Pad A Bit 9  | 529 | U16    | 0      | 1      | 0                | 0                | -          | R/W                      | QD*          | -              |
| Pad A Bit 10                                       | 530 | U16    | 0      | 1      | 0                | 0                | -          | R/W                      | QD*          | -              |
| Pad A Bit 11                                       | 531 | U16    | 0      | 1      | 0                | 0                | -          | R/W                      | QD*          | -              |
| Pad A Bit 12                                       | 532 | U16    | 0      | 1      | 0                | 0                | -          | R/W                      | QD*          | -              |
| Pad A Bit 13                                       | 533 | U16    | 0      | 1      | 0                | 0                | -          | R/W                      | QD*          | -              |
| Pad A Bit 14                                       | 534 | U16    | 0      | 1      | 0                | 0                | -          | R/W                      | QD*          | -              |
| Pad A Bit 15                                       | 535 | U16    | 0      | 1      | 0                | 0                | -          | R/W                      | QD*          | -              |
| Bitword pad B                                      | 536 | U16    | 0      | 65535  | 0                | 0                | ✓          | R/W                      | QD*          | R/W            |
| Pad B Bit 0  | 537 | U16    | 0      | 1      | 0                | 0                | -          | R/W                      | QD           | R              |
| Pad B Bit 1  | 538 | U16    | 0      | 1      | 0                | 0                | -          | R/W                      | QD           | R              |
| Pad B Bit 2  | 539 | U16    | 0      | 1      | 0                | 0                | -          | R/W                      | QD           | R              |
| Pad B Bit 3  | 540 | U16    | 0      | 1      | 0                | 0                | -          | R/W                      | QD           | R              |
| Pad B Bit 4  | 541 | U16    | 0      | 1      | 0                | 0                | -          | R/W                      | QD           | R              |
| Pad B Bit 5  | 542 | U16    | 0      | 1      | 0                | 0                | -          | R/W                      | QD           | R              |
| Pad B Bit 6  | 543 | U16    | 0      | 1      | 0                | 0                | -          | R/W                      | QD           | R              |
| Pad B Bit 7  | 544 | U16    | 0      | 1      | 0                | 0                | -          | R/W                      | QD           | R              |
| Pad B Bit 8  | 545 | U16    | 0      | 1      | 0                | 0                | -          | R/W                      | QD*          | -              |
| Pad B Bit 9  | 546 | U16    | 0      | 1      | 0                | 0                | -          | R/W                      | QD*          | -              |

| Parameter                         | No. | Format   | Value            |                    |                   |                   | Access via |                          |       |                |
|-----------------------------------|-----|--|------------------|--------------------|-------------------|-------------------|------------|--------------------------|-------|----------------|
|                                   |     |  | min              | max                | Factory American  | Factory European  | Keyp.      | RS485/<br>BUS/<br>Opt2-M | Term. | Opt2-A/<br>PDC |
| Pad B Bit 10                      | 547 | U16  | 0                | 1                  | 0                 | 0                 | -          | R/W                      | QD*   | -              |
| Pad B Bit 11                      | 548 | U16  | 0                | 1                  | 0                 | 0                 | -          | R/W                      | QD*   | -              |
| Pad B Bit 12                      | 549 | U16  | 0                | 1                  | 0                 | 0                 | -          | R/W                      | QD*   | -              |
| Pad B Bit 13                      | 550 | U16  | 0                | 1                  | 0                 | 0                 | -          | R/W                      | QD*   | -              |
| Pad B Bit 14                      | 551 | U16  | 0                | 1                  | 0                 | 0                 | -          | R/W                      | QD*   | -              |
| Pad B Bit 15                      | 552 | U16  | 0                | 1                  | 0                 | 0                 | -          | R/W                      | QD*   | -              |
| Source                            | 553 | U16  | 0                | 65535              | 0                 | 0                 | ✓          | R/W                      | -     | -              |
| Destination                       | 554 | U16  | 0                | 65535              | 0                 | 0                 | ✓          | R/W                      | -     | -              |
| Mul gain                          | 555 | Float  | -10000           | +10000             | 1                 | 1                 | ✓          | R/W                      | -     | -              |
| Div gain                          | 556 | Float  | -10000           | +10000             | 1                 | 1                 | ✓          | R/W                      | -     | -              |
| Input max                         | 557 | Float  | -2 <sup>31</sup> | 2 <sup>31</sup> -1 | 0                 | 0                 | ✓          | R/W                      | -     | -              |
| Input min                         | 558 | Float  | -2 <sup>31</sup> | 2 <sup>31</sup> -1 | 0                 | 0                 | ✓          | R/W                      | -     | -              |
| Input offset                      | 559 | Float  | -2 <sup>31</sup> | 2 <sup>31</sup> -1 | 0                 | 0                 | ✓          | R/W                      | -     | -              |
| Output offset                     | 560 | Float  | -2 <sup>31</sup> | 2 <sup>31</sup> -1 | 0                 | 0                 | ✓          | R/W                      | -     | -              |
| Inp absolute                      | 561 | U16  | 0                | 1                  | OFF               | OFF               | ✓          | R/W<br>0<br>1            | -     | -              |
|                                   |     | OFF<br>ON  |                  |                    |                   |                   |            |                          |       |                |
| Tacho scale                       | 562 | Float  | 0.90             | 3.00               | 1.00              | 1.00              | ✓          | R/W                      | -     | -              |
| Speed offset                      | 563 | Float  | -20.00           | +20.00             | 0.00              | 0.00              | ✓          | R/W                      | -     | -              |
| Dig input term                    | 564 | U16  | 0                | 65535              | -                 | -                 | -          | R                        | -     | R              |
| Dig input term 1                  | 565 | U16  | 0                | 1                  | -                 | -                 | -          | R                        | -     | R              |
| Dig input term 2                  | 566 | U16  | 0                | 1                  | -                 | -                 | -          | R                        | -     | R              |
| Dig input term 3                  | 567 | U16  | 0                | 1                  | -                 | -                 | -          | R                        | -     | R              |
| Dig input term 4                  | 568 | U16  | 0                | 1                  | -                 | -                 | -          | R                        | -     | R              |
| Dig input term 5                  | 569 | U16  | 0                | 1                  | -                 | -                 | -          | R                        | -     | R              |
| Dig input term 6                  | 570 | U16  | 0                | 1                  | -                 | -                 | -          | R                        | -     | R              |
| Dig input term 7                  | 571 | U16  | 0                | 1                  | -                 | -                 | -          | R                        | -     | R              |
| Dig input term 8                  | 572 | U16  | 0                | 1                  | -                 | -                 | -          | R                        | -     | R              |
| Dig input term 9                  | 573 | U16  | 0                | 1                  | -                 | -                 | -          | R                        | -     | R              |
| Dig input term 10                 | 574 | U16  | 0                | 1                  | -                 | -                 | -          | R                        | -     | R              |
| Dig input term 11                 | 575 | U16  | 0                | 1                  | -                 | -                 | -          | R                        | -     | R              |
| Dig input term 12                 | 576 | U16  | 0                | 1                  | -                 | -                 | -          | R                        | -     | R              |
| Dig input term 15                 | 579 | U16  | 0                | 1                  | -                 | -                 | -          | R                        | -     | R              |
| Dig input term 16                 | 580 | U16  | 0                | 1                  | -                 | -                 | -          | R                        | -     | R              |
| Dig output term                   | 581 | U16  | 0                | 65535              | -                 | -                 | -          | R                        | -     | R              |
| Virtual dig inp                   | 582 | U16  | 0                | 65535              | -                 | -                 | ✓          | R                        | -     | -              |
| Virtual dig out                   | 583 | U16  | 0                | 65535              | -                 | -                 | ✓          | R                        | -     | -              |
| Overcurrent thr [%]               | 584 | U16  | 0                | 200                | 160               | 160               | ✓          | R/W                      | -     | -              |
| Restart time [ms]                 | 585 | U16  | 0                | 10000              | 0                 | 0                 | ✓          | R/W                      | -     | -              |
| Hold off time [ms]                | 586 | U16  | 0                | 10000              | 0                 | 0                 | ✓          | R/W                      | -     | -              |
| E int [V]                         | 587 | I16  | -80              | +80                | -                 | -                 | ✓          | R                        | QA    | -              |
| Mains frequency [Hz]              | 588 | Float  | 0.0              | 70.0               | -                 | -                 | ✓          | R                        | -     | -              |
| Stop mode                         | 626 | U16  | 0                | 3                  | Stop &<br>Speed 0 | Stop &<br>Speed 0 | ✓          | R/Z<br>0<br>1<br>2<br>3  | -     | -              |
|                                   |     | OFF<br>Stop & speed 0<br>Fast stp & spd 0<br>Fst / stp & spd 0 |                  |                    |                   |                   |            |                          |       |                |
| Spd 0 trip delay [ms]             | 627 | U16  | 0                | 40000              | 0                 | 0                 | ✓          | R/W                      | -     | -              |
| Trip cont delay [ms]              | 628 | U16  | 0                | 40000              | 0                 | 0                 | ✓          | R/W                      | -     | -              |
| Relay 2<br>(Select like output 1) | 629 | U16  | 0                | 77                 | Stop ctrl<br>(23) | Stop ctrl<br>(23) | ✓          | R/Z                      | -     | -              |
| Jog stop control                  | 630 | U16  | 0                | 1                  | OFF               | OFF               | ✓          | R/Z<br>0<br>1            | -     | -              |
|                                   |     | OFF<br>ON  |                  |                    |                   |                   |            |                          |       |                |

| Parameter  | No. | Format | Value |                    |                  |                  | Access via |                                   |       |                         |  |
|--|-----|--------|-------|--------------------|------------------|------------------|------------|-----------------------------------|-------|-------------------------|--|
|  |     |        | min   | max                | Factory American | Factory European | Keyp.      | RS485/<br>BUS/<br>Opt2-M          | Term. | Opt2-A/<br>PDC          |  |
| Latch<br>ON<br>OFF   | 633 | U16    | 0     | 1                  | ON               | ON               | ✓          | R/Z<br>1<br>0                     | -     | -                       |  |
| Activity<br>Ignore<br>Warning<br>Disable drive<br>Quick stop<br>Normal stop<br>Curr lim stop | 634 | U16    | 0     | 5                  | Disable drive    | Disable drive    | ✓          | R/Z<br>0<br>1<br>2<br>3<br>4<br>5 | -     | -                       |  |
| Ok relay open<br>ON<br>OFF   | 635 | I16    | 0     | 1                  | ON               | ON               | ✓          | R/W<br>1<br>0                     | -     | -                       |  |
| Hold off time [ms]   | 636 | U16    | 0     | 10000              | 0                | 0                | ✓          | R/W                               | -     | -                       |  |
| Restart time [ms]  | 637 | U16    | 0     | 10000              | 0                | 0                | ✓          | R/W                               | -     | -                       |  |
| Activity<br>Disable drive<br>Quick stop<br>Normal stop<br>Curr lim stop                      | 639 | U16    | 0     | 5                  | Disable drive    | Disable drive    | ✓          | R/Z<br>2<br>3<br>4<br>5           | -     | -                       |  |
| Ok relay open<br>ON<br>OFF   | 640 | I16    | 0     | 1                  | ON               | ON               | ✓          | R/W<br>1<br>0                     | -     | -                       |  |
| Encoder 1 state<br>Encoder Fault<br>Encoder ok   | 648 | U16    | 0     | 1                  |                  |                  | -          | R<br>0<br>1                       | QD    | R<br>0<br>1             |  |
| Refresh enc 1<br>Enabled<br>Disabled   | 649 | U16    | 0     | 1                  | Disabled (0)     | Disabled (0)     | ✓          | R/W<br>1<br>0                     | -     | -                       |  |
| Encoder 2 state<br>Encoder Fault<br>Encoder ok   | 651 | U16    | 0     | 1                  |                  |                  | -          | R<br>0<br>1                       | QD    | R<br>0<br>1             |  |
| Refresh enc 2<br>Enabled<br>Disabled   | 652 | U16    | 0     | 1                  | Disabled (0)     | Disabled (0)     | ✓          | R/W<br>1<br>0                     | -     | -                       |  |
| Motor I2t accum  | 655 | Float  | 0.00  | 100.00             | -                | -                | ✓          | R                                 | -     | -                       |  |
| Acc delta speed0 [FF]  | 659 | U32    | 0     | 2 <sup>32</sup> -1 | 100              | 100              | ✓          | R/W                               | -     | -                       |  |
| Acc delta time 0 [s]   | 660 | U16    | 0     | 65535              | 1                | 1                | ✓          | R/W                               | -     | -                       |  |
| Dec delta speed0 [FF]  | 661 | U32    | 0     | 2 <sup>32</sup> -1 | 100              | 100              | ✓          | R/W                               | -     | -                       |  |
| Dec delta time 0 [s]   | 662 | U16    | 0     | 65535              | 1                | 1                | ✓          | R/W                               | -     | -                       |  |
| S acc t const [ms]   | 663 | Float  | 100   | 3000               | 300              | 300              | ✓          | R/W                               | -     | -                       |  |
| S dec t const [ms]   | 664 | Float  | 100   | 3000               | 300              | 300              | ✓          | R/W                               | -     | -                       |  |
| S acc t const 0 [ms]   | 665 | Float  | 100   | 3000               | 300              | 300              | ✓          | R/W                               | -     | -                       |  |
| S dec t const 0 [ms]   | 666 | Float  | 100   | 3000               | 300              | 300              | ✓          | R/W                               | -     | -                       |  |
| S acc t const 1 [ms]   | 667 | Float  | 100   | 3000               | 300              | 300              | ✓          | R/W                               | -     | -                       |  |
| S dec t const 1 [ms]   | 668 | Float  | 100   | 3000               | 300              | 300              | ✓          | R/W                               | -     | -                       |  |
| S acc t const 2 [ms]   | 669 | Float  | 100   | 3000               | 300              | 300              | ✓          | R/W                               | -     | -                       |  |
| S dec t const 2 [ms]   | 670 | Float  | 100   | 3000               | 300              | 300              | ✓          | R/W                               | -     | -                       |  |
| S acc t const 3 [ms]   | 671 | Float  | 100   | 3000               | 300              | 300              | ✓          | R/W                               | -     | -                       |  |
| S dec t const 3 [ms]   | 672 | Float  | 100   | 3000               | 300              | 300              | ✓          | R/W                               | -     | -                       |  |
| Fwd-Rev<br>No direction<br>Fwd direction<br>Rev direction<br>No direction                    | 673 | U16    | 0     | 3                  | 1                | 1                | ✓          | R/W<br>0<br>1<br>2<br>3           | ID    | R/W<br>0<br>1<br>2<br>3 |  |
| PI steady thr  | 695 | I16    | 0     | 10000              | 0                | 0                | ✓          | R/W                               | -     | -                       |  |
| Droop gain [%]   | 696 | Float  | 0.00  | 100.00             | 0.00             | 0.00             | ✓          | R/W                               | -     | -                       |  |
| Droop filter [ms]  | 697 | U16    | 0     | 1000               | 0                | 0                | ✓          | R/W                               | -     | -                       |  |
| Load comp [%]  | 698 | I16    | -200  | +200               | 0                | 0                | ✓          | R/W                               | IA    | R/W                     |  |

| Parameter  | No. | Format | Value              |                           |                  |                  | Access via |                          |       |                |
|--|-----|--------|--------------------|---------------------------|------------------|------------------|------------|--------------------------|-------|----------------|
|  |     |        | min                | max                       | Factory American | Factory European | Keyp.      | RS485/<br>BUS/<br>Opt2-M | Term. | Opt2-A/<br>PDC |
| Enable droop<br>Enabled<br>Disabled              | 699 | U16    | 0                  | 1                         | Disabled<br>(0)  | Disabled<br>(0)  | ✓          | R/W<br>1<br>0            | ID    | R/W<br>1<br>0  |
| Droop limit [FF]                                 | 700 | U16    | 0                  | 2*P45                     | 1500             | 1500             | ✓          | R/W                      | -     | -              |
| T current lim type<br>T lim +/-<br>T lim mot gen | 715 | U16    | 0                  | 1                         | 0                | 0                | ✓          | R/Z<br>0<br>1            | -     | -              |
| Activity<br>Ignore<br>Disable drive              | 728 | U16    | 0                  | 2                         | Disable<br>drive | Disable<br>drive | ✓          | R/Z<br>0<br>2            | -     | -              |
| Latch<br>ON<br>OFF                               | 729 | U16    | 0                  | 1                         | ON               | ON               | ✓          | R/Z<br>1<br>0            | -     | -              |
| Ok relay open<br>ON<br>OFF                       | 730 | U16    | 0                  | 1                         | ON               | ON               | ✓          | R/W<br>1<br>0            | -     | -              |
| PI steady delay                                  | 731 | U16    | 0                  | 60000                     | 0                | 0                | ✓          | R/W                      | -     | -              |
| I init gain PID                                  | 734 | Float  | 0.00               | 100.00                    | 10.00            | 10.00            | ✓          | R/W                      | -     | -              |
| I/n curve<br>Enabled<br>Disabled                 | 750 | U16    | 0                  | 1                         | 0                | 0                | ✓          | R/Z<br>1<br>0            | -     | -              |
| I/n lim 0 [%]                                    | 751 | U16    | 0                  | 200                       | 0                | 0                | ✓          | R/Z                      | -     | -              |
| I/n lim 1 [%]                                    | 752 | U16    | 0                  | 200                       | 0                | 0                | ✓          | R/Z                      | -     | -              |
| I/n lim 2 [%]                                    | 753 | U16    | 0                  | 200                       | 0                | 0                | ✓          | R/Z                      | -     | -              |
| I/n lim 3 [%]                                    | 754 | U16    | 0                  | 200                       | 0                | 0                | ✓          | R/Z                      | -     | -              |
| I/n lim 4 [%]                                    | 755 | U16    | 0                  | 200                       | 0                | 0                | ✓          | R/Z                      | -     | -              |
| In speed [rpm]                                   | 756 | U16    | 0                  | P162                      | 0                | 0                | ✓          | R/Z                      | -     | -              |
| PID clamp  | 757 | I16    | -10000             | +10000                    | 10000            | 10000            | ✓          | R/W                      | -     | -              |
| Feed-fwd PID                                     | 758 | I16    | -10000             | +10000                    | 0                | 0                | ✓          | R                        | IA    | R              |
| PID error  | 759 | I16    | -10000             | +10000                    | 0                | 0                | ✓          | R                        | -     | R              |
| PID offset 0                                     | 760 | I16    | -10000             | +10000                    | 0                | 0                | ✓          | R/W                      | IA    | R/W            |
| PID offset 1                                     | 761 | I16    | -10000             | +10000                    | 0                | 0                | ✓          | R/W                      | -     | -              |
| PID offs. Sel<br>Offset 0<br>Offset 1            | 762 | U16    | 0                  | 1                         | 0                | 0                | ✓          | R/W<br>0<br>1            | ID    | R/W            |
| PID feed-back                                    | 763 | I16    | -10000             | +10000                    | 0                | 0                | ✓          | R/W                      | IA    | R/W            |
| PI I gain PID                                    | 764 | Float  | 0.00               | 100.00                    | 10.00            | 10.00            | ✓          | R/W                      | -     | -              |
| PI P gain PID                                    | 765 | Float  | 0.00               | 100.00                    | 10.00            | 10.00            | ✓          | R/W                      | -     | -              |
| PD D gain 1 PID [%]                              | 766 | Float  | 0.00               | 100.00                    | 1.00             | 1.00             | ✓          | R/W                      | -     | -              |
| PD D filter PID [ms]                             | 767 | U16    | 0                  | 1000                      | 0                | 0                | ✓          | R/W                      | -     | -              |
| PD P gain 1 PID [%]                              | 768 | Float  | 0.00               | 100.00                    | 10.00            | 10.00            | ✓          | R/W                      | -     | -              |
| Enable PI PID<br>Enabled<br>Disabled             | 769 | U16    | 0                  | 1                         | Disable          | Disable          | ✓          | R/W<br>1<br>0            | ID    | R/W            |
| Enable PD PID<br>Enabled<br>Disabled             | 770 | U16    | 0                  | 1                         | Disable          | Disable          | ✓          | R/W<br>1<br>0            | ID    | R/W            |
| PI output PID                                    | 771 | I16    | 0                  | 1000 x<br>PI top<br>limit | 1000             | 1000             | ✓          | R                        | -     | R              |
| PID out sign PID<br>Positive<br>Bipolar          | 772 | U16    | 0                  | 1                         | 1                | 1                | ✓          | R/W<br>0<br>1            | -     | -              |
| PID out scale                                    | 773 | Float  | -100.000           | +100.000                  | 1.000            | 1.000            | ✓          | R/W                      | -     | -              |
| PID output                                       | 774 | I16    | -10000             | +10000                    | 0                | 0                | ✓          | R                        | QA    | R              |
| PI central v1                                    | 776 | Float  | PI bot-<br>tom lim | PI top<br>lim             | 1.00             | 1.00             | ✓          | R/W                      | -     | -              |
| PI central v2                                    | 777 | Float  | PI bot-<br>tom lim | PI top<br>Lim             | 1.00             | 1.00             | ✓          | R/W                      | -     | -              |

| Parameter             | No.  | Format | Value              |                     |                  |                  | Access via |                          |        |                |
|-----------------------|------|--------|--------------------|---------------------|------------------|------------------|------------|--------------------------|--------|----------------|
|                       |      |        | min                | max                 | Factory American | Factory European | Keyp.      | RS485/<br>BUS/<br>Opt2-M | Term.  | Opt2-A/<br>PDC |
| PI central v3         | 778  | Float  | PI bot-<br>tom lim | PI top<br>Lim       | 1.00             | 1.00             | ✓          | R/W                      | IA     | -              |
| PI central v sel      | 779  | U16    | 0                  | 3                   | 1                | 1                | ✓          | R/W                      | ID     | R/W            |
| PI central vs0        | 780  | U16    | 0                  | 1                   | 1                | 1                | -          | R/W                      | ID     | R/W            |
| PI central vs1        | 781  | U16    | 0                  | 1                   | 0                | 0                | -          | R/W                      | ID     | R/W            |
| PID target            | 782  | U16    | 0                  | 65535               | 0                | 0                | ✓          | R/W                      | -      | -              |
| PI integr freeze      | 783  | U16    | 0                  | 1                   | 0                | 0                | ✓          | R/W                      | ID     | R/W            |
| OFF<br>ON             |      |        |                    |                     |                  |                  |            | 0<br>1                   |        |                |
| PI top lim            | 784  | Float  | PI bot-<br>tom lim | 10.00               | 10.00            | 10.00            | ✓          | R/W                      | -      | -              |
| PI bottom lim         | 785  | Float  | -10.00             | PI top<br>lim       | 0.0              | 0.0              | ✓          | R/W                      | -      | -              |
| PID source            | 786  | U16    | 0                  | 65535               | 0                | 0                | ✓          | R/W                      | -      | -              |
| PID source gain       | 787  | Float  | -100.000           | +100.00             | 1.000            | 1.000            | ✓          | R/W                      | -      | -              |
| PD P gain 2 PID [%]   | 788  | Float  | 0.00               | 100.00              | 10.00            | 10.00            | ✓          | R/W                      | -      | -              |
| PD D gain 2 PID [%]   | 789  | Float  | 0.00               | 100.00              | 1.00             | 1.00             | ✓          | R/W                      | -      | -              |
| PD P gain 3 PID [%]   | 790  | Float  | 0.00               | 100.00              | 10.00            | 10.00            | ✓          | R/W                      | -      | -              |
| PD D gain 3 PID[%]    | 791  | Float  | 0.00               | 100.00              | 1.00             | 1.00             | ✓          | R/W                      | -      | -              |
| Input 1 filter [ms]   | 792  | U16    | 0                  | 1000                | 0                | 0                | ✓          | R/W                      | -      | R/W            |
| P init gain PID       | 793  | Float  | 0.00               | 100.00              | 10.00            | 10.00            | ✓          | R/W                      | -      | -              |
| Diameter calc         | 794  | U16    | 0                  | 1                   | 0                | 0                | ✓          | Z/R                      | ID     | R/W            |
| Enabled<br>Disabled   |      |        |                    |                     |                  |                  |            | 1<br>0                   |        |                |
| Positioning spd [rpm] | 795  | I16    | -100               | +100                | 0                | 0                | ✓          | R/W                      | -      | -              |
| Max deviation         | 796  | I16    | 0                  | +10000              | 8000             | 8000             | ✓          | R/W                      | -      | -              |
| Gear box ratio        | 797  | Float  | 0.001              | 1.000               | 1.000            | 1.000            | ✓          | R/W                      | -      | -              |
| Dancer constant [mm]  | 798  | U16    | 1                  | 10000               | 1                | 1                | ✓          | R/W                      | -      | -              |
| Minimum diameter [mm] | 799  | U16    | 1                  | 2000                | 100              | 100              | ✓          | R/Z                      | -      | -              |
| Diameter calc st      | 800  | U16    | 0                  | 1                   | 0                | 0                | -          | R                        | QD     | R              |
| Input 2 filter [ms]   | 801  | U16    | 0                  | 1000                | 0                | 0                | ✓          | R/W                      | -      | R/W            |
| Input 3 filter [ms]   | 802  | U16    | 0                  | 1000                | 0                | 0                | ✓          | R/W                      | -      | R/W            |
| Enable ind store      | 911  | U16    | 0                  | 1                   | Disabled<br>(0)  | Disabled<br>(0)  | ✓          | R/W                      | -      | R/W            |
| Enabled<br>Disabled   |      |        |                    |                     |                  |                  |            | 1<br>0                   |        |                |
| Ind store ctrl        | 912  | U16    | 0                  | 65535               | 0                | 0                | -          | R/W                      | -      | R/W            |
| Index storing         | 913  | U32    | 0                  | +2 <sup>32</sup> -1 | 0                | 0                | -          | R                        | -      | R              |
| I field cnst 40       | 916  | Float  | 0.0                | 100.0               | 40.0             | 40.0             | ✓          | R/Z                      | -      | -              |
| I field cnst 70       | 917  | Float  | 0.0                | 100.0               | 70.0             | 70.0             | ✓          | R/Z                      | -      | -              |
| I field cnst 90       | 918  | Float  | 0.0                | 100.0               | 90.0             | 90.0             | ✓          | R/Z                      | -      | -              |
| Set flux / if         | 919  | U16    | 0                  | 1                   | 0                | 0                | ✓          | Z/C                      | -      | -              |
| Reset flux / if       | 920  | U16    | 0                  | 1                   | 0                | 0                | ✓          | Z/C                      | -      | -              |
| Out vlt level         | 921  | Float* | 0.00               | 100.0               | 100.0            | 100.0            | ✓          | R/W                      | IA, QA | R/W            |
| Act spd filter [s]    | 923  | Float  | 0.001              | 1.000               | 0.100            | 0.100            | ✓          | R/W                      | -      | -              |
| Act spd filter [s]    | 923  | Float  | 0.001              | 1.000               | 0.100            | 0.100            | ✓          | R/W                      | -      | -              |
| F act spd (rpm)       | 924  | I16    | -32768             | +32767              | -                | -                | ✓          | R                        | QA     | R              |
| F act spd (d) [FF]    | 925  | I16    | -32768             | +32767              | -                | -                | ✓          | R                        | -      | R              |
| T curr filter [s]     | 926  | Float  | 0.001              | 0.250               | 0.100            | 0.100            | ✓          | R/W                      | -      | -              |
| F T curr (%)          | 928  | I16    | -500               | +500                | -                | -                | ✓          | R                        | QA     | R              |
| Inertia c filter [ms] | 1012 | U16    | 0                  | 1000                | 0                | 0                | ✓          | R/W                      | -      | -              |
| Torque const [N*m/A]  | 1013 | Float  | 0.01               | 99.99               | S                | S                | ✓          | R                        | -      | -              |
| Inertia [kg*m*m*]     | 1014 | Float  | 0.001              | 999.999             | S                | S                | ✓          | R/W                      | -      | -              |
| Friction [N*m]        | 1015 | Float  | 0.000              | 99.999              | S                | S                | ✓          | R/W                      | -      | -              |



| Parameter   | No.  | Format | Value  |         |                           |                           | Access via |                              |              |                |
|---|------|--------|--------|---------|---------------------------|---------------------------|------------|------------------------------|--------------|----------------|
|   |      |        | min    | max     | Factory American          | Factory European          | Keyp.      | RS485/<br>BUS/<br>Opt2-M     | Term.        | Opt2-A/<br>PDC |
| Aux spd fun sel<br>Speed up<br>Inertia-loss cp                                | 1016 | U16    | 0      | 1       | Speed up<br>(0)           | Speed up<br>(0)           | ✓          | R/Z<br>0<br>1                | -            | -              |
| Speed ratio   | 1017 | I16    | 0      | +32767  | +10000                    | +10000                    | ✓          | R/W                          | IA           | R/W            |
| Speed draw out (d)  | 1018 | I16    | -32768 | +32767  | -                         | -                         | ✓          | R                            | QA           | R/W            |
| Speed draw out (%)  | 1019 | Float  | -200.0 | +200.0  | -                         | -                         | ✓          | R                            | -            | -              |
| Select enc 1<br>OFF<br>Speed ref 1<br>Speed ref 2<br>Ramp ref 1<br>Ramp ref 2 | 1020 | U16    | 0      | 5       | OFF<br>(0)<br>see 6.12.05 | OFF<br>(0)<br>see 6.12.05 | ✓          | R/Z<br>0<br>2<br>3<br>4<br>5 | -            | -              |
| Select enc 2<br>OFF<br>Speed ref 1<br>Speed ref 2<br>Ramp ref 1<br>Ramp ref 2 | 1021 | U16    | 0      | 5       | OFF<br>(0)<br>see 6.12.05 | OFF<br>(0)<br>see 6.12.05 | ✓          | R/Z<br>0<br>2<br>3<br>4<br>5 | -            | -              |
| Start   | 1027 | U16    | 0      | 65535   | -                         | -                         | ✓          | C                            | -            | -              |
| Take val  | 1028 | U16    | 0      | 65535   | -                         | -                         | ✓          | Z/C                          | -            | -              |
| Fwd-Rev spd tune<br>Fwd direction<br>Rev direction                            | 1029 | U16    | 1      | 2       | Fwd<br>Direction<br>(1)   | Fwd<br>Direction<br>(1)   | ✓          | R/Z<br>1<br>2                | -            | -              |
| Inertia Nw [kg*m*m*]  | 1030 | Float  | 0.001  | 999.999 | -                         | -                         | ✓          | R                            | -            | -              |
| Friction Nw [N*m]   | 1031 | Float  | 0.000  | 99.99   | -                         | -                         | ✓          | R                            | -            | -              |
| Speed P Nw [%]  | 1032 | Float  | 0.00   | 100.00  | -                         | -                         | ✓          | R                            | -            | -              |
| Speed I Nw [%]  | 1033 | Float  | 0.00   | 100.00  | -                         | -                         | ✓          | R                            | -            | -              |
| Input 1 compare   | 1042 | I16    | -10000 | +10000  | 0                         | 0                         | ✓          | R/W                          | -            | -              |
| Input 1 cp error  | 1043 | U16    | 0      | 10000   | 0                         | 0                         | ✓          | R/W                          | -            | -              |
| Input 1 cp delay  | 1044 | U16    | 0      | 65000   | 0                         | 0                         | ✓          | R/W                          | -            | -              |
| Input 1 cp match<br>Input 1 not thr.val.<br>Input 1=thr.val                   | 1045 | U16    | 0      | 1       | -                         | -                         | -          | R<br>0<br>1                  | QD<br>L<br>H | R              |
| PID acc time  | 1046 | Float  | 0.0    | 900.0   | 0.0                       | 0.0                       | ✓          | R/W                          | -            | -              |
| PID dec time  | 1047 | Float  | 0.0    | 900.0   | 0.0                       | 0.0                       | ✓          | R/W                          | -            | -              |
| Test T curr lim [%]   | 1048 | U16    | 0      | S       | 20                        | 20                        | ✓          | R/Z                          | -            | -              |
| Output power [kW]   | 1052 | Float  | 0.01   | 9999.99 | -                         | -                         | ✓          | R                            | -            | -              |
| Maximum diameter [m]  | 1153 | Float  | 0.000  | 32.000  | 1.000                     | 1.000                     | ✓          | R/Z                          | -            | -              |
| Roll diameter [m]   | 1154 | Float  | 0.000  | 32.000  |                           |                           | ✓          | R                            | QA           | -              |
| Ref speed thr [%]   | 1155 | Float  | 0      | 150.00  | 5                         | 5                         | ✓          | R/W                          | -            | -              |
| Line speed gain   | 1156 | I16    | 0      | 32767   | 0                         | 0                         | ✓          | R/W                          | -            | -              |
| Diam reset  | 1157 | U16    | 0      | 1       | 0                         | 0                         | ✓          | R/W                          | ID           | R/W            |
| Diam thr [%]  | 1158 | Float  | 0      | 150.00  | 10                        | 10                        | ✓          | R/W                          | -            | -              |
| Diam reached  | 1159 | U16    | 0      | 1       |                           |                           | ✓          | R                            | QD           | R              |
| Line speed [%]  | 1160 | Float  | 0.00   | 200.00  |                           |                           | ✓          | R                            | -            | -              |
| Diam calc Dis<br>ON<br>OFF  | 1161 | U16    | 0      | 1       | ON<br>(1)                 | ON<br>(1)                 | ✓          | R/W<br>1<br>0                | ID           | R/W            |
| Diam filter [ms]  | 1162 | U16    | 0      | 5000    | 100                       | 100                       | ✓          | R/W                          | -            | -              |
| Base omega [rpm]  | 1163 | U16    | 0      | 8191    | 1500                      | 1500                      | ✓          | R/W                          | -            | -              |
| Diam preset 0 [m]   | 1164 | Float  | 0.000  | 32.000  | 0                         | 0                         | ✓          | R/W                          | -            | -              |
| Diam preset 1 [m]   | 1165 | Float  | 0.000  | 32.000  | 0                         | 0                         | ✓          | R/W                          | -            | -              |
| Diam preset 2 [m]   | 1166 | Float  | 0.000  | 32.000  | 0                         | 0                         | ✓          | R/W                          | -            | -              |



| Parameter             | No.  | Format | Value   |         |                  |                  | Access via |                          |       |                |
|-----------------------|------|--------|---------|---------|------------------|------------------|------------|--------------------------|-------|----------------|
|                       |      |        | min     | max     | Factory American | Factory European | Keyp.      | RS485/<br>BUS/<br>Opt2-M | Term. | Opt2-A/<br>PDC |
| Diam preset 3 [m]     | 1167 | Float  | 0.000   | 32.000  | 0                | 0                | ✓          | R/W                      | IA    | -              |
| Diam preset sel       | 1168 | U16    | 0       | 3       | 0                | 0                | ✓          | R/W                      | ID    | -              |
| Variable J comp [%]   | 1171 | Float  | 0.00    | 199.99  | 0                | 0                | ✓          | R/W                      | -     | -              |
| Constant J comp [%]   | 1172 | Float  | -100.00 | +100.00 | 0                | 0                | ✓          | R/W                      | -     | -              |
| Mat width [%]         | 1173 | Float  | 0.00    | 100.00  | 100              | 100              | ✓          | R/W                      | -     | -              |
| Static f [%]          | 1174 | Float  | 0.00    | 199.99  | 0                | 0                | ✓          | R/W                      | -     | -              |
| Dinamic f [%]         | 1175 | Float  | 0.00    | 199.99  | 0                | 0                | ✓          | R/W                      | -     | -              |
| Taper enable          | 1176 | U16    | 0       | 1       | Disabled<br>(0)  | Disabled<br>(0)  | ✓          | R/W                      | ID    | R/W            |
| Enabled<br>Disabled   |      |        |         |         |                  |                  |            | 1<br>0                   |       |                |
| Init diameter [m]     | 1177 | Float  | 0.000   | 32.000  | 0.1              | 0.1              | ✓          | R/W                      | -     | -              |
| Final diameter [m]    | 1178 | Float  | 0.000   | 32.000  | 1                | 1                | ✓          | R/W                      | -     | -              |
| Tension red [%]       | 1179 | Float  | 0.00    | 199.99  | 0                | 0                | ✓          | R/W                      | IA    | -              |
| Tension ref [%]       | 1180 | Float  | 0.00    | 199.99  | 0                | 0                | ✓          | R/W                      | IA    | -              |
| Tension scale [%]     | 1181 | I16    | 0       | 200     | 100              | 100              | ✓          | R/W                      | -     | -              |
| Time acc/dec min [s]  | 1182 | Float  | 0.15    | 300.00  | 9.01             | 9.01             | ✓          | R/W                      | -     | -              |
| Int acc calc En       | 1183 | U16    | 0       | 1       | Enabled<br>(1)   | Enabled<br>(1)   | ✓          | R/Z                      | -     | -              |
| Enabled<br>Disabled   |      |        |         |         |                  |                  |            | 1<br>0                   |       |                |
| Line acc [%]          | 1184 | Float  | 0.00    | 100.00  | 100              | 100              | ✓          | R/W                      | -     | -              |
| Line dec [%]          | 1185 | Float  | 0.00    | 100.00  | 100              | 100              | ✓          | R/W                      | -     | -              |
| Line fast stop [%]    | 1186 | Float  | 0.00    | 100.00  | 100              | 100              | ✓          | R/W                      | -     | -              |
| Wind/unwind           | 1187 | U16    | 0       | 1       | Winder<br>(0)    | Winder<br>(0)    | ✓          | R/W                      | ID    | R/W            |
| Unwinder<br>Winder    |      |        |         |         |                  |                  |            | 1<br>0                   |       |                |
| Line acc status       | 1188 | U16    | 0       | 1       | OFF              | OFF              | ✓          | R/W                      | ID    | R/W            |
| Line dec status       | 1189 | U16    | 0       | 1       | OFF              | OFF              | ✓          | R/W                      | ID    | R/W            |
| Line fstp status      | 1190 | U16    | 0       | 1       | OFF              | OFF              | ✓          | R/W                      | ID    | R/W            |
| Act const J comp [%]  | 1191 | Float  | -       | 200.00  | 0                | 0                | ✓          | R                        | -     | -              |
| Act var J comp [%]    | 1192 | Float  | -       | 200.00  | 0                | 0                | ✓          | R                        | -     | -              |
| Torque current [%]    | 1193 | Float  | 0.00    | 200.00  |                  |                  | ✓          | R                        | QA    | -              |
| Act tension ref [%]   | 1194 | Float  | 0.00    | 200.00  | 0                | 0                | ✓          | R                        | QA    | -              |
| Speed match           | 1195 | U16    | 0       | 1       | OFF<br>(0)       | OFF<br>(0)       | ✓          | R/W                      | ID    | R/W            |
| ON<br>OFF             |      |        |         |         |                  |                  |            | 1<br>0                   |       |                |
| Spd match acc [s]     | 1196 | Float  | 0.30    | 300.00  | 83.88            | 83.88            | ✓          | R/W                      | -     | -              |
| Spd match dec [s]     | 1197 | Float  | 0.30    | 300.00  | 83.88            | 83.88            | ✓          | R/W                      | -     | -              |
| Offset acc time [s]   | 1198 | Float  | 0.30    | 950.00  | 83.88            | 83.88            | ✓          | R/W                      | -     | -              |
| W offset [rpm]        | 1199 | I16    | 0       | 1000    | 0                | 0                | ✓          | R/W                      | -     | -              |
| Spd match gain [%]    | 1200 | U16    | 0       | 150     | 100              | 100              | ✓          | R/W                      | -     | -              |
| Winder side           | 1201 | U16    | 0       | 1       | Up<br>(0)        | Up<br>(0)        | ✓          | R/W                      | ID    | R/W            |
| Down<br>Up            |      |        |         |         |                  |                  |            | 1<br>0                   |       |                |
| W gain [%]            | 1202 | U16    | 0       | 100     | 0                | 0                | ✓          | R/W                      | -     | -              |
| Spd match compl       | 1203 | U16    | 0       | 1       |                  |                  | ✓          | R                        | QD    | R              |
| Line spd source       | 1204 | U16    | 0       | 65535   | 0                | 0                | ✓          | R/Z                      | -     | -              |
| Diam inc/dec En       | 1205 | U16    | 0       | 1       | Enabled<br>(0)   | Enabled<br>(0)   | ✓          | R/W                      | ID    | R/W            |
| Enabled<br>Disabled   |      |        |         |         |                  |                  |            | 1<br>0                   |       |                |
| Diam init filter [ms] | 1206 | U16    | 0       | 5000    | 100              | 100              | ✓          | R/W                      | -     | -              |
| Diam stdy delay [ms]  | 1207 | U16    | 0       | 60000   | 0                | 0                | ✓          | R/W                      | -     | -              |
| Close loop comp       | 1208 | I16    | -32767  | +32767  |                  |                  | ✓          | R                        | -     | -              |

| Parameter                               | No.  | Format | Value            |                    |                  |                  | Access via |                          |       |                |
|---|------|--------|------------------|--------------------|------------------|------------------|------------|--------------------------|-------|----------------|
|   |      |        | min              | max                | Factory American | Factory European | Keyp.      | RS485/<br>BUS/<br>Opt2-M | Term. | Opt2-A/<br>PDC |
| Torque winder En<br>Enabled<br>Disabled | 1209 | U16    | 0                | 1                  | Disabled<br>0    | Disabled<br>0    | ✓          | R/W<br>1<br>0            | ID    | R/W            |
| W target                                | 1210 | U16    | 0                | 65535              | 0                | 0                | ✓          | R/Z                      | -     | -              |
| Acc/dec filter [ms]                     | 1212 | U16    | 0                | 5000               | 30               | 30               | ✓          | R/W                      | -     | -              |
| Actual comp [%]                         | 1213 | I16    | -200             | +200               |                  |                  | ✓          | R                        | QD    | -              |
| Closed loop En<br>Enabled<br>Disabled   | 1214 | U16    | 0                | 1                  | Disabled<br>(0)  | Disabled<br>(0)  | ✓          | R/Z<br>1<br>0            | -     | R/Z            |
| Speed demand En<br>Enabled<br>Disabled  | 1215 | U16    | 0                | 1                  | Disabled<br>(0)  | Disabled<br>(0)  | ✓          | R/W<br>1<br>0            | -     | R/W            |
| Spd match torque [%]                    | 1216 | U16    | 0                | 200                | 100              | 100              | ✓          | R/W                      | -     | -              |
| W reference [rpm]                       | 1217 | I16    | -8192            | +8192              |                  |                  | ✓          | R                        | QA    | -              |
| Source                                  | 1218 | U16    | 0                | 65535              | 0                | 0                | ✓          | R/W                      | -     | -              |
| Destination                             | 1219 | U16    | 0                | 65535              | 0                | 0                | ✓          | R/W                      | -     | -              |
| Mul gain                                | 1220 | Float  | -10000           | +10000             | 1                | 1                | ✓          | R/W                      | -     | -              |
| Div gain                                | 1221 | Float  | -10000           | +10000             | 1                | 1                | ✓          | R/W                      | -     | -              |
| Input max                               | 1222 | Float  | -231             | 231-1              | 0                | 0                | ✓          | R/W                      | -     | -              |
| Input min                               | 1223 | Float  | -231             | 231-1              | 0                | 0                | ✓          | R/W                      | -     | -              |
| Input offset                            | 1224 | Float  | -231             | 231-1              | 0                | 0                | ✓          | R/W                      | -     | -              |
| Output offset                           | 1225 | Float  | -231             | 231-1              | 0                | 0                | ✓          | R/W                      | -     | -              |
| Inp absolute<br>ON<br>OFF               | 1226 | U16    | 0                | 1                  | OFF<br>0         | OFF<br>0         | ✓          | R/W<br>1<br>0            | -     | -              |
| Source                                  | 1227 | U16    | 0                | 65535              | 0                | 0                | ✓          | R/W                      | -     | -              |
| Destination                             | 1228 | U16    | 0                | 65535              | 0                | 0                | ✓          | R/W                      | -     | -              |
| Mul gain                                | 1229 | Float  | -10000           | +10000             | 1                | 1                | ✓          | R/W                      | -     | -              |
| Div gain                                | 1230 | Float  | -10000           | +10000             | 1                | 1                | ✓          | R/W                      | -     | -              |
| Input max                               | 1231 | Float  | -2 <sup>31</sup> | 2 <sup>31</sup> -1 | 0                | 0                | ✓          | R/W                      | -     | -              |
| Input min                               | 1232 | Float  | -2 <sup>31</sup> | 2 <sup>31</sup> -1 | 0                | 0                | ✓          | R/W                      | -     | -              |
| Input offset                            | 1233 | Float  | -2 <sup>31</sup> | 2 <sup>31</sup> -1 | 0                | 0                | ✓          | R/W                      | -     | -              |
| Output offset                           | 1234 | Float  | -2 <sup>31</sup> | 2 <sup>31</sup> -1 | 0                | 0                | ✓          | R/W                      | -     | -              |
| Inp absolute<br>ON<br>OFF               | 1235 | U16    | 0                | 1                  | OFF<br>0         | OFF<br>0         | ✓          | R/W<br>1<br>0            | -     | -              |
| Source                                  | 1236 | U16    | 0                | 65535              | 0                | 0                | ✓          | R/W                      | -     | -              |
| Destination                             | 1237 | U16    | 0                | 65535              | 0                | 0                | ✓          | R/W                      | -     | -              |
| Mul gain                                | 1238 | Float  | -10000           | +10000             | 1                | 1                | ✓          | R/W                      | -     | -              |
| Div gain                                | 1239 | Float  | -10000           | +10000             | 1                | 1                | ✓          | R/W                      | -     | -              |
| Input max                               | 1240 | Float  | -2 <sup>31</sup> | 2 <sup>31</sup> -1 | 0                | 0                | ✓          | R/W                      | -     | -              |
| Input min                               | 1241 | Float  | -2 <sup>31</sup> | 2 <sup>31</sup> -1 | 0                | 0                | ✓          | R/W                      | -     | -              |
| Input offset                            | 1242 | Float  | -2 <sup>31</sup> | 2 <sup>31</sup> -1 | 0                | 0                | ✓          | R/W                      | -     | -              |
| Output offset                           | 1243 | Float  | -2 <sup>31</sup> | 2 <sup>31</sup> -1 | 0                | 0                | ✓          | R/W                      | -     | -              |
| Inp absolute<br>ON<br>OFF               | 1244 | U16    | 0                | 1                  | OFF<br>0         | OFF<br>0         | ✓          | R/W<br>1<br>0            | -     | -              |
| Source                                  | 1245 | U16    | 0                | 65535              | 0                | 0                | ✓          | R/W                      | -     | -              |
| Destination                             | 1246 | U16    | 0                | 65535              | 0                | 0                | ✓          | R/W                      | -     | -              |
| Mul gain                                | 1247 | Float  | -10000           | +10000             | 1                | 1                | ✓          | R/W                      | -     | -              |
| Div gain                                | 1248 | Float  | -10000           | +10000             | 1                | 1                | ✓          | R/W                      | -     | -              |
| Input max                               | 1249 | Float  | -2 <sup>31</sup> | 2 <sup>31</sup> -1 | 0                | 0                | ✓          | R/W                      | -     | -              |
| Input min                               | 1250 | Float  | -2 <sup>31</sup> | 2 <sup>31</sup> -1 | 0                | 0                | ✓          | R/W                      | -     | -              |
| Input offset                            | 1251 | Float  | -2 <sup>31</sup> | 2 <sup>31</sup> -1 | 0                | 0                | ✓          | R/W                      | -     | -              |

| Parameter           | No.  | Format | Value            |                    |                  |                  | Access via |                          |       |                |
|---------------------|------|--------|------------------|--------------------|------------------|------------------|------------|--------------------------|-------|----------------|
|                     |      |        | min              | max                | Factory American | Factory European | Keyp.      | RS485/<br>BUS/<br>Opt2-M | Term. | Opt2-A/<br>PDC |
| Output offset       | 1252 | Float  | -2 <sup>31</sup> | 2 <sup>31</sup> -1 | 0                | 0                | ✓          | R/W                      | -     | -              |
| Inp absolute        | 1253 | U16    | 0                | 1                  | OFF<br>0         | OFF<br>0         | ✓          | R/W                      | -     | -              |
| ON<br>OFF           |      |        |                  |                    |                  |                  |            | 1<br>0                   |       |                |
| Jog TW speed [%]    | 1255 | I16    | 0                | 100                | 0                | 0                | ✓          | R/W                      | -     | -              |
| Jog TW enable       | 1256 | U16    | 0                | 1                  | Disabled<br>(0)  | Disabled<br>(0)  | ✓          | R/W                      | ID    | R/W            |
| Enabled<br>Disabled |      |        |                  |                    |                  |                  |            | 1<br>0                   |       |                |
| Enable PI-PD PID    | 1258 | U16    | 0                | 1                  | Disabled<br>0    | Disabled<br>0    | -          | R/W                      | ID    | R/W            |
| Enabled<br>Disabled |      |        |                  |                    |                  |                  |            | 1<br>0                   |       |                |
| Closing speed [rpm] | 1262 | U16    | 0                | 200                | 30               | 30               | ✓          | R/W                      | -     | -              |
| Actuator delay [ms] | 1266 | U16    | 0                | 30000              | 1000             | 1000             | ✓          | R/W                      | -     | -              |
| Inversion out 1     | 1267 | U16    | 0                | 1                  | Disabled<br>(0)  | Disabled<br>(0)  | ✓          | R/W                      | -     | -              |
| Enabled<br>Disabled |      |        |                  |                    |                  |                  |            | 1<br>0                   |       |                |
| Inversion out 2     | 1268 | U16    | 0                | 1                  | Disabled<br>(0)  | Disabled<br>(0)  | ✓          | R/W                      | -     | -              |
| Enabled<br>Disabled |      |        |                  |                    |                  |                  |            | 1<br>0                   |       |                |
| Inversion out 3     | 1269 | U16    | 0                | 1                  | Disabled<br>(0)  | Disabled<br>(0)  | ✓          | R/W                      | -     | -              |
| Enabled<br>Disabled |      |        |                  |                    |                  |                  |            | 1<br>0                   |       |                |
| Inversion out 4     | 1270 | U16    | 0                | 1                  | Disabled<br>(0)  | Disabled<br>(0)  | ✓          | R/W                      | -     | -              |
| Enabled<br>Disabled |      |        |                  |                    |                  |                  |            | 1<br>0                   |       |                |
| Inversion out 5     | 1271 | U16    | 0                | 1                  | Disabled<br>(0)  | Disabled<br>(0)  | ✓          | R/W                      | -     | -              |
| Enabled<br>Disabled |      |        |                  |                    |                  |                  |            | 1<br>0                   |       |                |
| Inversion out 6     | 1272 | U16    | 0                | 1                  | Disabled<br>(0)  | Disabled<br>(0)  | ✓          | R/W                      | -     | -              |
| Enabled<br>Disabled |      |        |                  |                    |                  |                  |            | 1<br>0                   |       |                |
| Inversion out 7     | 1273 | U16    | 0                | 1                  | Disabled<br>(0)  | Disabled<br>(0)  | ✓          | R/W                      | -     | -              |
| Enabled<br>Disabled |      |        |                  |                    |                  |                  |            | 1<br>0                   |       |                |
| Inversion out 8     | 1274 | U16    | 0                | 1                  | Disabled<br>(0)  | Disabled<br>(0)  | ✓          | R/W                      | -     | -              |
| Enabled<br>Disabled |      |        |                  |                    |                  |                  |            | 1<br>0                   |       |                |
| Inversion relay 2   | 1275 | U16    | 0                | 1                  | Disabled<br>(0)  | Disabled<br>(0)  | ✓          | R/W                      | -     | -              |
| Enabled<br>Disabled |      |        |                  |                    |                  |                  |            | 1<br>0                   |       |                |
| Inversion in 1      | 1276 | U16    | 0                | 1                  | Disabled<br>(0)  | Disabled<br>(0)  | ✓          | R/W                      | -     | -              |
| Enabled<br>Disabled |      |        |                  |                    |                  |                  |            | 1<br>0                   |       |                |
| Inversion in 2      | 1277 | U16    | 0                | 1                  | Disabled<br>(0)  | Disabled<br>(0)  | ✓          | R/W                      | -     | -              |
| Enabled<br>Disabled |      |        |                  |                    |                  |                  |            | 1<br>0                   |       |                |
| Inversion in 3      | 1278 | U16    | 0                | 1                  | Disabled<br>(0)  | Disabled<br>(0)  | ✓          | R/W                      | -     | -              |
| Enabled<br>Disabled |      |        |                  |                    |                  |                  |            | 1<br>0                   |       |                |
| Inversion in 4      | 1279 | U16    | 0                | 1                  | Disabled<br>(0)  | Disabled<br>(0)  | ✓          | R/W                      | -     | -              |
| Enabled<br>Disabled |      |        |                  |                    |                  |                  |            | 1<br>0                   |       |                |

| Parameter  | No.  | Format | Value |        |                  |                  | Access via |                                   |       |                |
|--|------|--------|-------|--------|------------------|------------------|------------|-----------------------------------|-------|----------------|
|  |      |        | min   | max    | Factory American | Factory European | Keyp.      | RS485/<br>BUS/<br>Opt2-M          | Term. | Opt2-A/<br>PDC |
| Inversion in 5<br>Enabled<br>Disabled  | 1280 | U16    | 0     | 1      | Disabled<br>(0)  | Disabled<br>(0)  | ✓          | R/W<br>1<br>0                     | -     | -              |
| Inversion in 6<br>Enabled<br>Disabled  | 1281 | U16    | 0     | 1      | Disabled<br>(0)  | Disabled<br>(0)  | ✓          | R/W<br>1<br>0                     | -     | -              |
| Inversion in 7<br>Enabled<br>Disabled  | 1282 | U16    | 0     | 1      | Disabled<br>(0)  | Disabled<br>(0)  | ✓          | R/W<br>1<br>0                     | -     | -              |
| Inversion in 8<br>Enabled<br>Disabled  | 1283 | U16    | 0     | 1      | Disabled<br>(0)  | Disabled<br>(0)  | ✓          | R/W<br>1<br>0                     | -     | -              |
| Ref spd source   | 1284 | U16    | 0     | 65535  | 0                | 0                | ✓          | R/Z                               | -     | -              |
| Ref speed gain   | 1285 | I16    | 0     | 32767  | 0                | 0                | ✓          | R/W                               | -     | -              |
| Ref line speed [%]   | 1286 | Float  | 0.00  | 200.00 |                  |                  | ✓          | R                                 | -     | -              |
| Static f Zero<br>Enabled<br>Disabled   | 1287 | U16    | 0     | 1      | Disabled<br>(0)  | Disabled<br>(0)  | ✓          | R/W<br>1<br>0                     | -     | -              |
| Motor ovrl d preal.  | 1289 | U16    | 0     | 1      | -                | -                | ✓          | R                                 | -     | -              |
| Torque delay [ms]  | 1293 | I16    | 0     | 30000  | 3000             | 3000             | ✓          | R/W                               | -     | -              |
| Torque proving [%]   | 1294 | I16    | 0     | 200    | 75               | 75               | ✓          | R/W                               | -     | -              |
| Enable Torque pr<br>Activity   | 1295 | I16    | 0     | 1      | Disabled         | Disabled         | ✓          | R/W                               | -     | -              |
| Ignore<br>Warning<br>Disable drive<br>Quick stop<br>Normal stop<br>Curr lim stop             | 1296 | U16    | 0     | 5      | Disable<br>drive | Disable<br>drive | ✓          | R/Z<br>0<br>1<br>2<br>3<br>4<br>5 | -     | -              |
| Ok relay open<br>ON<br>OFF   | 1297 | I16    | 0     | 1      | ON               | ON               | ✓          | R/W<br>0<br>1                     | -     | -              |
| Activity<br>Ignore<br>Warning<br>Disable drive   | 1419 | U16    | 0     | 2      | Disable<br>drive | Disable<br>drive | ✓          | R/Z<br>0<br>1<br>2                | -     | -              |
| Ok relay open<br>ON<br>OFF   | 1420 | I16    | 0     | 1      | ON               | ON               | ✓          | R/W<br>0<br>1                     | -     | -              |
| Latch<br>ON<br>OFF   | 1421 | U16    | 0     | 1      | ON               | ON               | ✓          | R/Z<br>1<br>0                     | -     | -              |
| Activity<br>Ignore<br>Warning<br>Disable drive<br>Quick stop<br>Normal stop<br>Curr lim stop | 1422 | U16    | 0     | 2      | Ignore           | Ignore           | ✓          | R/Z<br>0<br>1<br>2<br>3<br>4<br>5 | -     | -              |
| Ok relay open<br>ON<br>OFF   | 1423 | I16    | 0     | 1      | ON               | ON               | ✓          | R/W<br>1<br>0                     | -     | -              |
| Hold off time [ms]   | 1424 | U16    | 0     | 10000  | 0                | 0                | ✓          | R/W                               | -     | -              |
| Restart time [ms]  | 1425 | U16    | 0     | 10000  | 0                | 0                | ✓          | R/W                               | -     | -              |
| Overspeed thr [rpm]  | 1426 | Float  | 0     | 5000   | 4000             | 4000             | ✓          | R/Z                               | -     | -              |
| Mot cur threshld [%]   | 1430 | U16    | 0     | 200    | 100              | 100              | ✓          | R/W                               | -     | -              |
| Mot cur th delay [ms]  | 1431 | U16    | 0     | 65535  | 1000             | 1000             | ✓          | R/W                               | -     | -              |
| Activity<br>Ignore<br>Warning<br>Disable drive   | 1432 | U16    | 0     | 2      | Ignore           | Ignore           | ✓          | R/Z<br>0<br>1<br>2                | -     | -              |

| Parameter                  | No.  | Format | Value |        |                  |                  | Access via |                          |       |                |
|----------------------------|------|--------|-------|--------|------------------|------------------|------------|--------------------------|-------|----------------|
|                            |      |        | min   | max    | Factory American | Factory European | Keyp.      | RS485/<br>BUS/<br>Opt2-M | Term. | Opt2-A/<br>PDC |
| Latch<br>ON<br>OFF         | 1433 | U16    | 0     | 1      | ON               | ON               | ✓          | R/Z<br>0<br>1            | -     | -              |
| Ok relay open<br>ON<br>OFF | 1434 | I16    | 0     | 1      | ON               | ON               | ✓          | R/W<br>0<br>1            | -     | -              |
| Hold off time [ms]         | 1435 | U16    | 0     | 10000  | 0                | 0                | ✓          | R/W                      | -     | -              |
| Restart time [ms]          | 1436 | U16    | 0     | 10000  | 0                | 0                | ✓          | R/W                      | -     | -              |
| Delta freq thres [%]       | 1437 | Float  | 1     | 15     | 5                | 5                | ✓          | R/Z                      | -     | -              |
| Drive ovrlld preal.        | 1438 | U16    | 0     | 1      | -                | -                | ✓          | R                        | -     | -              |
| Drive I2t accum            | 1439 | Float  | 0.00  | 100.00 | -                | -                | ✓          | R                        | -     | -              |
| Ok relay open<br>ON<br>OFF | 1441 | I16    | 0     | 1      | ON               | ON               | ✓          | R/W<br>0<br>1            | -     | -              |
| Latch<br>ON<br>OFF         | 1442 | U16    | 0     | 1      | ON               | ON               | ✓          | R/Z<br>0<br>1            | -     | -              |
| Adap P gain 4 [%]          | 1462 | Float  | 0.00  | 100.00 | 10.00            | 10.00            | ✓          | R/W                      | -     | -              |
| Adap I gain 4 [%]          | 1463 | Float  | 0.00  | 100.00 | 1.00             | 1.00             | ✓          | R/W                      | -     | -              |
| Adap selector              | 1464 | U16    | 0     | 3      | 0                | 0                | ✓          | R/W                      | -     | -              |
| dI/dt delta time           | 1520 | U16    | 0     | 100    | 0                | 0                | ✓          | R/W                      | -     | -              |
| En Tcurr HiRes             | 1521 | I16    | 0     | 1      | 0                | 0                | ✓          | R/Z                      | -     | -              |



## 10.3 PARAMETERS IN ALPHABETICAL ORDER

| Parameter             | No.  | Position   |
|-----------------------|------|--|
| 2B + E                | 201  | CONFIGURATION \ Drive type                                 |
| Acc delta speed [FF]  | 21   | START UP   |
| Acc delta speed [FF]  | 21   | RAMP \ Acceleration  |
| Acc delta speed [FF]  | 21   | DRIVECOM \ Acceleration                                    |
| Acc delta speed0 [FF] | 659  | FUNCTIONS \ Multi ramp fct \ Ramp 0 \ Acceleration 0       |
| Acc delta speed1 [FF] | 23   | FUNCTIONS \ Multi ramp fct \ Ramp 1 \ Acceleration 1       |
| Acc delta speed2 [FF] | 25   | FUNCTIONS \ Multi ramp fct \ Ramp 2 \ Acceleration 2       |
| Acc delta speed3 [FF] | 27   | FUNCTIONS \ Multi ramp fct \ Ramp 3 \ Acceleration 3       |
| Acc delta time [s]    | 22   | START UP   |
| Acc delta time [s]    | 22   | RAMP \ Acceleration  |
| Acc delta time [s]    | 22   | DRIVECOM \ Acceleration                                    |
| Acc delta time 0 [s]  | 660  | FUNCTIONS \ Multi ramp fct \ Ramp 0 \ Acceleration 0       |
| Acc delta time 1 [s]  | 24   | FUNCTIONS \ Multi ramp fct \ Ramp 1 \ Acceleration 1       |
| Acc delta time 2 [s]  | 26   | FUNCTIONS \ Multi ramp fct \ Ramp 2 \ Acceleration 2       |
| Acc delta time 3 [s]  | 28   | FUNCTIONS \ Multi ramp fct \ Ramp 3 \ Acceleration 3       |
| Acc/dec filter [ms]   | 1212 | OPTIONS \ TORQUE WINDER \ Torque calculat \ Comp calculat  |
| Act const J comp [%]  | 1191 | OPTIONS \ TORQUE WINDER \ Torque calculat \ Comp calculat  |
| Act percentage [%]    | 120  | DRIVECOM   |
| Act spd filter [s]    | 923  | MONITOR \ Measurements \ Speed \ Speed in DRC [ ]          |
| Act spd filter [s]    | 923  | MONITOR \ Measurements \ Speed \ Speed in rpm              |
| Act speed value [FF]  | 119  | DRIVECOM   |
| Act tension ref [%]   | 1194 | OPTIONS \ TORQUE WINDER \ Torque calculat                  |
| Act tension ref [%]   | 1194 | OPTIONS \ TORQUE WINDER \ Torque calculat \ Taper function |
| Act var J comp [%]    | 1192 | OPTIONS \ TORQUE WINDER \ Torque calculat \ Comp calculat  |
| Activity              | 203  | CONFIGURATION \ Prog alarms \ Overvoltage                  |
| Activity              | 212  | CONFIGURATION \ Prog alarms \ Overcurrent                  |
| Activity              | 354  | CONFIGURATION \ Prog alarms \ External fault               |
| Activity              | 365  | CONFIGURATION \ Prog alarms \ Overtemp motor               |
| Activity              | 368  | CONFIGURATION \ Prog alarms \ Heatsink                     |
| Activity              | 386  | CONFIGURATION \ Prog alarms \ Hw opt1 failure              |
| Activity              | 473  | CONFIGURATION \ Prog alarms \ Field loss                   |
| Activity              | 478  | CONFIGURATION \ Prog alarms \ Delta frequency              |
| Activity              | 634  | CONFIGURATION \ Prog alarms \ Bus loss                     |
| Activity              | 639  | CONFIGURATION \ Prog alarms \ Opt2 failure                 |
| Activity              | 728  | CONFIGURATION \ Prog alarms \ Enable seq err               |
| Activity              | 1296 | CONFIGURATION \ Prog alarms \ Brake fault                  |
| Activity              | 1422 | CONFIGURATION \ Prog alarms \ Overspeed                    |
| Activity              | 1432 | CONFIGURATION \ Prog alarms \ Delta frequency              |
| Activity              | 1419 | CONFIGURATION \ Prog alarms \ Motor I2t ovrl d             |
| Actual comp [%]       | 1213 | OPTIONS \ TORQUE WINDER \ Torque calculat \ Comp calculat  |
| Actual spd (%)        | 121  | MONITOR \ Measurements \ Speed \ Speed in %                |
| Actual spd (d) [FF]   | 119  | MONITOR \ Measurements \ Speed \ Speed in DRC [ ]          |
| Actual spd (rpm)      | 122  | DRIVE STATUS   |
| Actual spd (rpm)      | 122  | MONITOR \ Measurements \ Speed \ Speed in rpm              |
| Actuator delay [ms]   | 1266 | FUNCTIONS \ Brake control                                  |
| Adap I gain 1 [%]     | 189  | ADD SPEED FUNCT \ Adaptive spd reg                         |
| Adap I gain 2 [%]     | 191  | ADD SPEED FUNCT \ Adaptive spd reg                         |
| Adap I gain 3 [%]     | 193  | ADD SPEED FUNCT \ Adaptive spd reg                         |

| Parameter             | No.  | Position  |
|-----------------------|------|---|
| Adap I gain 4 [%]     | 1463 | ADD SPEED FUNCT \ Adaptive spd reg                        |
| Adap joint 1 [%]      | 186  | ADD SPEED FUNCT \ Adaptive spd reg                        |
| Adap joint 2 [%]      | 187  | ADD SPEED FUNCT \ Adaptive spd reg                        |
| Adap P gain 1 [%]     | 188  | ADD SPEED FUNCT \ Adaptive spd reg                        |
| Adap P gain 2 [%]     | 190  | ADD SPEED FUNCT \ Adaptive spd reg                        |
| Adap P gain 3 [%]     | 192  | ADD SPEED FUNCT \ Adaptive spd reg                        |
| Adap P gain 4 [%]     | 1462 | ADD SPEED FUNCT \ Adaptive spd reg                        |
| Adap reference [FF]   | 183  | ADD SPEED FUNCT \ Adaptive spd reg                        |
| Adap selector         | 1464 | ADD SPEED FUNCT \ Adaptive spd reg                        |
| Adap speed 1 [%]      | 184  | ADD SPEED FUNCT \ Adaptive spd reg                        |
| Adap speed 2 [%]      | 185  | ADD SPEED FUNCT \ Adaptive spd reg                        |
| An in 1 target        | 295  | I/O CONFIG \ Analog inputs \ Analog input 1               |
| An in 2 target        | 296  | I/O CONFIG \ Analog inputs \ Analog input 2               |
| An in 3 target        | 297  | I/O CONFIG \ Analog inputs \ Analog input 3               |
| Arm inductance [mH]   | 454  | CURRENT REGULAT   |
| Arm resistance [ ]    | 453  | CURRENT REGULAT   |
| Auto capture          | 388  | ADD SPEED FUNCT   |
| Auto tune inp 1       | 259  | START UP \ Analog inputs \ Analog input 1                 |
| Auto tune inp 1       | 259  | I/O CONFIG \ Analog inputs \ Analog input 1               |
| Auto tune inp 2       | 260  | START UP \ Analog inputs \ Analog input 2                 |
| Auto tune inp 2       | 260  | I/O CONFIG \ Analog inputs \ Analog input 2               |
| Auto tune inp 3       | 261  | START UP \ Analog inputs \ Analog input 3                 |
| Auto tune inp 3       | 261  | I/O CONFIG \ Analog inputs \ Analog input 3               |
| Aux spd fun sel       | 1016 | SPEED REGULAT   |
| Base current [%]      | 313  | START UP \ Overload contr                                 |
| Base current [%]      | 313  | FUNCTIONS \ Overload contr                                |
| Base omega [rpm]      | 1163 | OPTIONS \ TORQUE WINDER \ Diam Calculatio                 |
| Bitword pad A         | 519  | SPEC FUNCTIONS \ Pad Parameters                           |
| Bitword pad B         | 536  | SPEC FUNCTIONS \ Pad Parameters                           |
| Close loop comp       | 1208 | OPTIONS \ TORQUE WINDER \ Torque calculat \ Comp calculat |
| Closed loop En        | 1214 | OPTIONS \ TORQUE WINDER \ Torque calculat \ Comp calculat |
| Closing speed [rpm]   | 1262 | FUNCTIONS \ Brake control                                 |
| Constant J comp [%]   | 1172 | OPTIONS \ TORQUE WINDER \ Torque calculat \ Comp calculat |
| Control mode          | 253  | START UP  |
| Control mode          | 253  | REG PARAMETERS \ In use values                            |
| Control word          | 55   | DRIVECOM  |
| Curr limit state      | 349  | LIMITS \ Current limits                                   |
| Current lim red [%]   | 13   | LIMITS \ Current limits                                   |
| Dancer constant [mm]  | 798  | OPTIONS \ PID \ Diameter calc                             |
| Dec delta speed [FF]  | 29   | START UP  |
| Dec delta speed [FF]  | 29   | RAMP \ Deceleration                                       |
| Dec delta speed [FF]  | 29   | DRIVECOM \ Deceleration                                   |
| Dec delta speed0 [FF] | 661  | FUNCTIONS \ Multi ramp fct \ Ramp 0 \ Deceleration 0      |
| Dec delta speed1 [FF] | 31   | FUNCTIONS \ Multi ramp fct \ Ramp 1 \ Deceleration 1      |
| Dec delta speed2 [FF] | 33   | FUNCTIONS \ Multi ramp fct \ Ramp 2 \ Deceleration 2      |
| Dec delta speed3 [FF] | 35   | FUNCTIONS \ Multi ramp fct \ Ramp 3 \ Deceleration 3      |
| Dec delta time [s]    | 30   | START UP  |
| Dec delta time [s]    | 30   | RAMP \ Deceleration                                       |
| Dec delta time [s]    | 30   | DRIVECOM \ Deceleration                                   |
| Dec delta time 0 [s]  | 662  | FUNCTIONS \ Multi ramp fct \ Ramp 0 \ Deceleration 0      |
| Dec delta time 1 [s]  | 32   | FUNCTIONS \ Multi ramp fct \ Ramp 1 \ Deceleration 1      |
| Dec delta time 2 [s]  | 34   | FUNCTIONS \ Multi ramp fct \ Ramp 2 \ Deceleration 2      |
| Dec delta time 3 [s]  | 36   | FUNCTIONS \ Multi ramp fct \ Ramp 3 \ Deceleration 3      |
| Delta freq thres [%]  | 1437 | CONFIGURATION \ Prog alarms \ Delta frequency             |
| dI/dt delta time      | 1520 | CURRENT REGULAT   |
| Destination           | 554  | SPEC FUNCTIONS \ Links \ Link 2                           |
| Destination           | 485  | SPEC FUNCTIONS \ Links \ Link 1                           |



| Parameter             | No.  | Position                                  |
|-----------------------|------|---|
| Destination           | 1219 | SPEC FUNCTIONS \ Links \ Link 3           |
| Destination           | 1228 | SPEC FUNCTIONS \ Links \ Link 4           |
| Destination           | 1237 | SPEC FUNCTIONS \ Links \ Link 5           |
| Destination           | 1246 | SPEC FUNCTIONS \ Links \ Link 6           |
| Device address        | 319  | CONFIGURATION \ Set serial comm           |
| Diam calc Dis         | 1161 | OPTIONS \ TORQUE WINDER \ Diam Calculatio |
| Diam filter [ms]      | 1162 | OPTIONS \ TORQUE WINDER \ Diam Calculatio |
| Diam inc/dec En       | 1205 | OPTIONS \ TORQUE WINDER \ Diam Calculatio |
| Diam init filter [ms] | 1206 | OPTIONS \ TORQUE WINDER \ Diam Calculatio |
| Diam preset 0 [m]     | 1164 | OPTIONS \ TORQUE WINDER \ Diam Calculatio |
| Diam preset 1 [m]     | 1165 | OPTIONS \ TORQUE WINDER \ Diam Calculatio |
| Diam preset 2 [m]     | 1166 | OPTIONS \ TORQUE WINDER \ Diam Calculatio |
| Diam preset 3 [m]     | 1167 | OPTIONS \ TORQUE WINDER \ Diam Calculatio |
| Diam preset sel       | 1168 | OPTIONS \ TORQUE WINDER \ Diam Calculatio |
| Diam reached          | 1159 | OPTIONS \ TORQUE WINDER \ Diam Calculatio |
| Diam reset            | 1157 | OPTIONS \ TORQUE WINDER \ Diam Calculatio |
| Diam stdy delay [ms]  | 1207 | OPTIONS \ TORQUE WINDER \ Diam Calculatio |
| Diam thr [%]          | 1158 | OPTIONS \ TORQUE WINDER \ Diam Calculatio |
| Diameter calc         | 794  | OPTIONS \ PID \ Diameter calc             |
| Diameter calc st      | 800  | OPTIONS \ PID                             |
| Dig input term        | 564  | MONITOR \ I/O                             |
| Dig input term 1      | 565  | MONITOR \ I/O                             |
| Dig input term 10     | 574  | MONITOR \ I/O                             |
| Dig input term 11     | 575  | MONITOR \ I/O                             |
| Dig input term 12     | 576  | MONITOR \ I/O                             |
| Dig input term 15     | 579  | MONITOR \ I/O                             |
| Dig input term 16     | 580  | MONITOR \ I/O                             |
| Dig input term 2      | 566  | MONITOR \ I/O                             |
| Dig input term 3      | 567  | MONITOR \ I/O                             |
| Dig input term 4      | 568  | MONITOR \ I/O                             |
| Dig input term 5      | 569  | MONITOR \ I/O                             |
| Dig input term 6      | 570  | MONITOR \ I/O                             |
| Dig input term 7      | 571  | MONITOR \ I/O                             |
| Dig input term 8      | 572  | MONITOR \ I/O                             |
| Dig input term 9      | 573  | MONITOR \ I/O                             |
| Dig output term       | 581  | MONITOR \ I/O                             |
| Digital I/Q           |      | DRIVE STATUS                              |
| Digital input 1       | 137  | I/O CONFIG \ Digital inputs               |
| Digital input 2       | 138  | I/O CONFIG \ Digital inputs               |
| Digital input 3       | 139  | I/O CONFIG \ Digital inputs               |
| Digital input 4       | 140  | I/O CONFIG \ Digital inputs               |
| Digital input 5       | 141  | I/O CONFIG \ Digital inputs               |
| Digital input 6       | 142  | I/O CONFIG \ Digital inputs               |
| Digital input 7       | 143  | I/O CONFIG \ Digital inputs               |
| Digital input 8       | 144  | I/O CONFIG \ Digital inputs               |
| Digital output 1      | 145  | I/O CONFIG \ Digital outputs              |
| Digital output 2      | 146  | I/O CONFIG \ Digital outputs              |
| Digital output 3      | 147  | I/O CONFIG \ Digital outputs              |
| Digital output 4      | 148  | I/O CONFIG \ Digital outputs              |
| Digital output 5      | 149  | I/O CONFIG \ Digital outputs              |
| Digital output 6      | 150  | I/O CONFIG \ Digital outputs              |
| Digital output 7      | 151  | I/O CONFIG \ Digital outputs              |
| Digital output 8      | 152  | I/O CONFIG \ Digital outputs              |
| Dim factor den        | 51   | CONFIGURATION \ Dimension fact            |
| Dim factor den        | 51   | DRIVECOM \ Dimension fact                 |
| Dim factor num        | 50   | CONFIGURATION \ Dimension fact            |
| Dim factor num        | 50   | DRIVECOM \ Dimension fact                 |

| Parameter           | No.  | Position  |
|---------------------|------|---|
| Dim factor text     | 52   | CONFIGURATION \ Dimension fact                            |
| Dim factor text     | 52   | DRIVECOM \ Dimension fact                                 |
| Dinamic f [%]       | 1175 | OPTIONS \ TORQUE WINDER \ Torque calculat \ Comp calculat |
| Div gain            | 487  | SPEC FUNCTIONS \ Links \ Link 1                           |
| Div gain            | 556  | SPEC FUNCTIONS \ Links \ Link 2                           |
| Div gain            | 1221 | SPEC FUNCTIONS \ Links \ Link 3                           |
| Div gain            | 1230 | SPEC FUNCTIONS \ Links \ Link 4                           |
| Div gain            | 1239 | SPEC FUNCTIONS \ Links \ Link 5                           |
| Div gain            | 1248 | SPEC FUNCTIONS \ Links \ Link 6                           |
| Drive I2t accum     | 1439 | STARTUP \ Overload contr                                  |
| Drive I2t accum     | 1439 | FUNCTIONS \ Overload contr                                |
| Drive ovrl d preal. | 1438 | STARTUP \ Overload contr                                  |
| Drive ovrl d preal. | 1438 | FUNCTIONS \ Overload contr                                |
| Drive ready         | 380  | -   |
| Drive size [A]      | 465  | CONFIGURATION \ Drive type                                |
| Drive type          | 300  | CONFIGURATION \ Drive type                                |
| Droop gain [%]      | 696  | SPEED REGULAT \ Droop function                            |
| Droop filter [ms]   | 697  | SPEED REGULAT \ Droop function                            |
| Droop limit [FF]    | 700  | SPEED REGULAT \ Droop function                            |
| E int [V]           | 587  | CURRENT REGULAT   |
| En TCurr HiRes      | 1521 | CONFIGURATION   |
| Enab multi rmp      | 243  | FUNCTIONS \ Multi ramp fct                                |
| Enab multi spd      | 153  | FUNCTIONS \ Multi speed fct                               |
| Enable drive        | 314  | DRIVE STATUS  |
| Enable drive        | 314  | START UP  |
| Enable drive        | 314  | TUNING  |
| Enable drive        | 314  | MONITOR   |
| Enable droop        | 699  | SPEED REGULAT \ Droop function                            |
| Enable fbk bypas    | 458  | CONFIGURATION \ Speed fbk                                 |
| Enable fbk contr    | 457  | START UP \ Speed feedback                                 |
| Enable fbk contr    | 457  | CONFIGURATION \ Speed fbk                                 |
| Enable flux reg     | 497  | FLUX REGULATION   |
| Enable flux weak    | 498  | FLUX REGULATION   |
| Enable ind store    | 911  | CONFIGURATION \ Speed fbk                                 |
| Enable jog          | 244  | FUNCTIONS \ Jog function                                  |
| Enable motor pot    | 246  | FUNCTIONS \ Motor pot                                     |
| Enable OPT2         | 425  | OPTIONS \ Option 2  |
| Enable overload     | 309  | START UP \ Overload contr                                 |
| Enable overload     | 309  | FUNCTIONS \ Overload contr                                |
| Enable PD PID       | 770  | OPTIONS \ PID   |
| Enable PI PID       | 769  | OPTIONS \ PID   |
| Enable PI-PD PID    | 1258 | OPTIONS \ PID   |
| Enable ramp         | 245  | RAMP  |
| Enable spd adap     | 181  | ADD SPEED FUNCT \ Adaptive spd reg                        |
| Enable spd reg      | 242  | SPEED REGULAT   |
| Enable spd=0 I      | 123  | SPEED REGULAT \ Spd zero logic                            |
| Enable spd=0 P      | 125  | SPEED REGULAT \ Spd zero logic                            |
| Enable spd=0 R      | 124  | SPEED REGULAT \ Spd zero logic                            |
| Enable Torque pr    | 1295 | FUNCTIONS \ Brake control                                 |
| Enc 1 speed (rpm)   | 427  | MONITOR \ Measurements \ Speed \ Speed in rpm             |
| Enc 2 speed (rpm)   | 420  | MONITOR \ Measurements \ Speed \ Speed in rpm             |
| Encoder 1 pulses    | 416  | CONFIGURATION \ Speed fbk                                 |
| Encoder 1 pulses    | 416  | I/O CONFIG \ Encoder inputs                               |
| Encoder 1 state     | 648  | CONFIGURATION \ Speed fbk                                 |
| Encoder 2 pulses    | 169  | START UP \ Speed feedback                                 |
| Encoder 2 pulses    | 169  | CONFIGURATION \ Speed fbk                                 |
| Encoder 2 pulses    | 169  | I/O CONFIG \ Encoder inputs                               |

| Parameter            | No.  | Position   |
|----------------------|------|--|
| Encoder 2 state      | 651  | CONFIGURATION \ Speed fbk                                  |
| F act spd (d) [FF]   | 925  | MONITOR \ Measurements \ Speed \ Speed in DRC [ ]          |
| F act spd (rpm)      | 924  | MONITOR \ Measurements \ Speed \ Speed in rpm              |
| F T curr (%)         | 928  | MONITOR \ Measurements                                     |
| Face value den       | 53   | CONFIGURATION \ Face value fact                            |
| Face value den       | 53   | DRIVECOM \ Face value fact                                 |
| Face value num       | 54   | CONFIGURATION \ Face value fact                            |
| Face value num       | 54   | DRIVECOM \ Face value fact                                 |
| Failure code         | 417  | SPEC FUNCTIONS   |
| Failure hour         | 328  | SPEC FUNCTIONS   |
| Failure minute       | 329  | SPEC FUNCTIONS   |
| Failure reg del      | 263  | SPEC FUNCTIONS   |
| Failure register     | 330  | SPEC FUNCTIONS   |
| Failure reset        | 262  | SPEC FUNCTIONS   |
| Failure text         | 327  | SPEC FUNCTIONS   |
| Fast stop            | 316  | -  |
| Feed-fwd PID         | 758  | OPTIONS \ PID \ PID source                                 |
| Final diameter [m]   | 1178 | OPTIONS \ TORQUE WINDER \ Torque calculat \ Taper function |
| Flux current (A)     | 351  | DRIVE STATUS   |
| Flux current (A)     | 351  | MONITOR \ Measurements                                     |
| Flux current [%]     | 234  | MONITOR \ Measurements                                     |
| Flux current [%]     | 234  | FLUX REGULATION  |
| Flux current max [%] | 467  | START UP \ Limits  |
| Flux current max [%] | 467  | LIMITS \ Flux limits                                       |
| Flux current min [%] | 468  | LIMITS \ Flux limits                                       |
| Flux current min [%] | 468  | START UP \ Limits  |
| Flux I [%]           | 92   | TUNING   |
| Flux I [%]           | 92   | REG PARAMETERS \ Percent values \ Field regulator          |
| Flux I Base          | 98   | REG PARAMETERS \ Base values \ Field regulator             |
| Flux P [%]           | 91   | TUNING   |
| Flux P [%]           | 91   | REG PARAMETERS \ Percent values \ Field regulator          |
| Flux P base          | 97   | REG PARAMETERS \ Base values \ Field regulator             |
| Flux reference [%]   | 500  | MONITOR \ Measurements                                     |
| Flux reference [%]   | 500  | FLUX REGULATION  |
| Flux reg mode        | 469  | START UP \ Motor data                                      |
| Flux reg mode        | 469  | FLUX REGULATION  |
| Flux weak speed [%]  | 456  | START UP \ Motor data                                      |
| Flux weak speed [%]  | 456  | CONFIGURATION \ Speed fbk                                  |
| Forward sign         | 293  | RAMP   |
| Freeze ramp          | 373  | RAMP   |
| Friction [N*m]       | 1015 | START UP \ Speed self tune                                 |
| Friction [N*m]       | 1015 | TUNING \ Speed self tune                                   |
| Friction [N*m]       | 1015 | SPEED REGULAT. \ Self tuning                               |
| Friction [N*m]       | 1015 | SPEED REGULAT \ Inertia/loss cp                            |
| Friction Nw [N*m]    | 1031 | START UP \ Speed self tune                                 |
| Friction Nw [N*m]    | 1031 | TUNING \ Speed self tune                                   |
| Friction Nw [N*m]    | 1031 | SPEED REGULAT. \ Self tuning                               |
| Full load curr [A]   | 179  | START UP \ Motor data                                      |
| Full load curr [A]   | 179  | REG PARAMETERS \ In use values                             |
| Fwd-Rev              | 673  | RAMP   |
| Fwd-Rev spd tune     | 1029 | START UP \ Speed self tune                                 |
| Fwd-Rev spd tune     | 1029 | TUNING \ Speed self tune                                   |
| Fwd-Rev spd tune     | 1029 | SPEED REGULAT. \ Self tuning                               |
| Gear box ratio       | 797  | OPTIONS \ PID \ Diameter calc                              |
| Gen amplitude [%]    | 60   | SPEC FUNCTIONS \ Test generator                            |
| Gen frequency [Hz]   | 59   | SPEC FUNCTIONS \ Test generator                            |
| Generator access     | 58   | SPEC FUNCTIONS \ Test generator                            |

| Parameter              | No.  | Position   |
|------------------------|------|--|
| Generator offset [%]   | 61   | SPEC FUNCTIONS \ Test generator                            |
| Hold off time [ms]     | 470  | CONFIGURATION \ Prog alarms \ Undervoltage                 |
| Hold off time [ms]     | 475  | CONFIGURATION \ Prog alarms \ Field loss                   |
| Hold off time [ms]     | 480  | CONFIGURATION \ Prog alarms \ Speed fbk loss               |
| Hold off time [ms]     | 482  | CONFIGURATION \ Prog alarms \ Overvoltage                  |
| Hold off time [ms]     | 502  | CONFIGURATION \ Prog alarms \ External fault               |
| Hold off time [ms]     | 586  | CONFIGURATION \ Prog alarms \ Overcurrent                  |
| Hold off time [ms]     | 636  | CONFIGURATION \ Prog alarms \ Bus loss                     |
| Hold off time [ms]     | 1424 | CONFIGURATION \ Prog alarms \ Overspeed                    |
| Hold off time [ms]     | 1435 | CONFIGURATION \ Prog alarms \ Delta frequency              |
| I field cnst 40        | 916  | FLUX REGULATION \ Flux \ if curve                          |
| I field cnst 70        | 917  | FLUX REGULATION \ Flux \ if curve                          |
| I field cnst 90        | 918  | FLUX REGULATION \ Flux \ if curve                          |
| I init gain PID        | 734  | OPTIONS \ PID \ PI controls                                |
| I/n curve              | 750  | FUNCTIONS \ Taper curr lim                                 |
| I/n lim 0 [%]          | 751  | FUNCTIONS \ Taper curr lim                                 |
| I/n lim 1 [%]          | 752  | FUNCTIONS \ Taper curr lim                                 |
| I/n lim 2 [%]          | 753  | FUNCTIONS \ Taper curr lim                                 |
| I/n lim 3 [%]          | 754  | FUNCTIONS \ Taper curr lim                                 |
| I/n lim 4 [%]          | 755  | FUNCTIONS \ Taper curr lim                                 |
| In use Tcur lim- [%]   | 11   | LIMITS \ Current limits                                    |
| In use Tcur lim+ [%]   | 10   | LIMITS \ Current limits                                    |
| Ind store ctrl         | 912  | CONFIGURATION \ Speed fbk                                  |
| Index storing          | 913  | CONFIGURATION \ Speed fbk                                  |
| Inertia [kg*m*m*]      | 1014 | START UP \ Speed self tune                                 |
| Inertia [kg*m*m*]      | 1014 | TUNING \ Speed self tune                                   |
| Inertia [kg*m*m*]      | 1014 | SPEED REGULAT. \ Self tuning                               |
| Inertia [kg*m*m]       | 1014 | SPEED REGULAT \ Inertia/loss cp                            |
| Inertia c filter [ms]  | 1012 | SPEED REGULAT \ Inertia/loss cp                            |
| Inertia Nw [kg*m*m*m*] | 1030 | START UP \ Speed self tune                                 |
| Inertia Nw [kg*m*m*m*] | 1030 | TUNING \ Speed self tune                                   |
| Inertia Nw [kg*m*m*m*] | 1030 | SPEED REGULAT. \ Self tuning                               |
| Init diameter [m]      | 1177 | OPTIONS \ TORQUE WINDER \ Torque calculat \ Taper function |
| Inp absolute           | 492  | SPEC FUNCTIONS \ Links \ Link 1                            |
| Inp absolute           | 1226 | SPEC FUNCTIONS \ Links \ Link 3                            |
| Inp absolute           | 1235 | SPEC FUNCTIONS \ Links \ Link 4                            |
| Inp absolute           | 1244 | SPEC FUNCTIONS \ Links \ Link 5                            |
| Inp absolute           | 1253 | SPEC FUNCTIONS \ Links \ Link 6                            |
| Inp absolute           | 561  | SPEC FUNCTIONS \ Links \ Link 2                            |
| Input 1 compare        | 1042 | I/O CONFIG \ Analog inputs \ Analog input 1                |
| Input 1 cp delay       | 1044 | I/O CONFIG \ Analog inputs \ Analog input 1                |
| Input 1 cp error       | 1043 | I/O CONFIG \ Analog inputs \ Analog input 1                |
| Input 1 cp match       | 1045 | I/O CONFIG \ Analog inputs \ Analog input 1                |
| Input 1 filter [ms]    | 792  | I/O CONFIG \ Analog inputs \ Analog input 1                |
| Input 2 filter [ms]    | 801  | I/O CONFIG \ Analog inputs \ Analog input 2                |
| Input 3 filter [ms]    | 802  | I/O CONFIG \ Analog inputs \ Analog input 3                |
| Input 1 sign           | 389  | I/O CONFIG \ Analog inputs \ Analog input 1                |
| Input 1 type           | 71   | I/O CONFIG \ Analog inputs \ Analog input 1                |
| Input 2 sign           | 390  | I/O CONFIG \ Analog inputs \ Analog input 2                |
| Input 2 type           | 76   | I/O CONFIG \ Analog inputs \ Analog input 2                |
| Input 3 sign           | 391  | I/O CONFIG \ Analog inputs \ Analog input 3                |
| Input 3 type           | 81   | I/O CONFIG \ Analog inputs \ Analog input 3                |
| Input max              | 557  | SPEC FUNCTIONS \ Links \ Link 2                            |
| Input max              | 488  | SPEC FUNCTIONS \ Links \ Link 1                            |
| Input max              | 1222 | SPEC FUNCTIONS \ Links \ Link 3                            |
| Input max              | 1231 | SPEC FUNCTIONS \ Links \ Link 4                            |
| Input max              | 1240 | SPEC FUNCTIONS \ Links \ Link 5                            |

| Parameter          | No.  | Position  |
|--------------------|------|---|
| Input max          | 1249 | SPEC FUNCTIONS \ Links \ Link 6                           |
| Input min          | 489  | SPEC FUNCTIONS \ Links \ Link 1                           |
| Input min          | 558  | SPEC FUNCTIONS \ Links \ Link 2                           |
| Input min          | 1223 | SPEC FUNCTIONS \ Links \ Link 3                           |
| Input min          | 1232 | SPEC FUNCTIONS \ Links \ Link 4                           |
| Input min          | 1241 | SPEC FUNCTIONS \ Links \ Link 5                           |
| Input min          | 1250 | SPEC FUNCTIONS \ Links \ Link 6                           |
| Input offset       | 490  | SPEC FUNCTIONS \ Links \ Link 1                           |
| Input offset       | 559  | SPEC FUNCTIONS \ Links \ Link 2                           |
| Input offset       | 1224 | SPEC FUNCTIONS \ Links \ Link 3                           |
| Input offset       | 1233 | SPEC FUNCTIONS \ Links \ Link 4                           |
| Input offset       | 1242 | SPEC FUNCTIONS \ Links \ Link 5                           |
| Input offset       | 1251 | SPEC FUNCTIONS \ Links \ Link 6                           |
| Int acc calc En    | 1183 | OPTIONS \ TORQUE WINDER \ Torque calculat \ Comp calculat |
| Inversion in 1     | 1276 | I/O CONFIG \ Digital inputs                               |
| Inversion in 2     | 1277 | I/O CONFIG \ Digital inputs                               |
| Inversion in 3     | 1278 | I/O CONFIG \ Digital inputs                               |
| Inversion in 4     | 1279 | I/O CONFIG \ Digital inputs                               |
| Inversion in 5     | 1280 | I/O CONFIG \ Digital inputs                               |
| Inversion in 6     | 1281 | I/O CONFIG \ Digital inputs                               |
| Inversion in 7     | 1282 | I/O CONFIG \ Digital inputs                               |
| Inversion in 8     | 1283 | I/O CONFIG \ Digital inputs                               |
| Inversion out 1    | 1267 | I/O CONFIG \ Digital outputs                              |
| Inversion out 2    | 1268 | I/O CONFIG \ Digital outputs                              |
| Inversion out 3    | 1269 | I/O CONFIG \ Digital outputs                              |
| Inversion out 4    | 1270 | I/O CONFIG \ Digital outputs                              |
| Inversion out 5    | 1271 | I/O CONFIG \ Digital outputs                              |
| Inversion out 6    | 1272 | I/O CONFIG \ Digital outputs                              |
| Inversion out 7    | 1273 | I/O CONFIG \ Digital outputs                              |
| Inversion out 8    | 1274 | I/O CONFIG \ Digital outputs                              |
| Inversion relay 2  | 1275 | I/O CONFIG \ Digital outputs                              |
| Jog -              | 399  | FUNCTIONS \ Jog function                                  |
| Jog +              | 398  | FUNCTIONS \ Jog function                                  |
| Jog operation      | 265  | FUNCTIONS \ Jog function                                  |
| Jog reference [FF] | 266  | FUNCTIONS \ Jog function                                  |
| Jog selection      | 375  | FUNCTIONS \ Jog function                                  |
| Jog stop control   | 630  | FUNCTIONS \ Stop control                                  |
| Jog TW enable      | 1256 | OPTIONS \ TORQUE WINDER \ Speed demand                    |
| Jog TW speed [%]   | 1255 | OPTIONS \ TORQUE WINDER \ Speed demand                    |
| Latch              | 194  | CONFIGURATION \ Prog alarms \ Failure supply              |
| Latch              | 355  | CONFIGURATION \ Prog alarms \ External fault              |
| Latch              | 357  | CONFIGURATION \ Prog alarms \ Undervoltage                |
| Latch              | 361  | CONFIGURATION \ Prog alarms \ Overvoltage                 |
| Latch              | 363  | CONFIGURATION \ Prog alarms \ Overcurrent                 |
| Latch              | 471  | CONFIGURATION \ Prog alarms \ Field loss                  |
| Latch              | 633  | CONFIGURATION \ Prog alarms \ Bus loss                    |
| Latch              | 729  | CONFIGURATION \ Prog alarms \ Enable seq err              |
| Latch              | 1421 | CONFIGURATION \ Prog alarms \ Overspeed                   |
| Latch              | 1433 | CONFIGURATION \ Prog alarms \ Delta frequency             |
| Latch              | 1442 | CONFIGURATION \ Prog alarms \ Motor I2t ovrlid            |
| Life time [h.min]  | 235  | SPEC FUNCTIONS  |
| Line acc [%]       | 1184 | OPTIONS \ TORQUE WINDER \ Torque calculat \ Comp calculat |
| Line acc status    | 1188 | OPTIONS \ TORQUE WINDER \ Torque calculat \ Comp calculat |
| Line dec [%]       | 1185 | OPTIONS \ TORQUE WINDER \ Torque calculat \ Comp calculat |
| Line dec status    | 1189 | OPTIONS \ TORQUE WINDER \ Torque calculat \ Comp calculat |
| Line fast stop [%] | 1186 | OPTIONS \ TORQUE WINDER \ Torque calculat \ Comp calculat |
| Line fstp status   | 1190 | OPTIONS \ TORQUE WINDER \ Torque calculat \ Comp calculat |



| Parameter             | No.  | Position  |
|-----------------------|------|---|
| Line spd source       | 1204 | OPTIONS \ TORQUE WINDER \ Diam Calculatio                 |
| Line speed [%]        | 1160 | OPTIONS \ TORQUE WINDER \ Diam Calculatio                 |
| Line speed gain       | 1156 | OPTIONS \ TORQUE WINDER \ Diam Calculatio                 |
| Load comp [%]         | 698  | SPEED REGULAT \ Droop function                            |
| Load default          | 258  | SPEC FUNCTIONS  |
| Lock speed I          | 348  | SPEED REGULAT   |
| Lock speed reg        | 322  | SPEED REGULAT   |
| Main commands         | 252  | START UP  |
| Main commands         | 252  | REG PARAMETERS \ In use values                            |
| Mains frequency [Hz]  | 588  | MONITOR \ Measurements                                    |
| Mains voltage [V]     | 466  | DRIVE STATUS  |
| Mains voltage [V]     | 466  | MONITOR \ Measurements                                    |
| Malfunction code      | 57   | DRIVECOM  |
| Mat width [%]         | 1173 | OPTIONS \ TORQUE WINDER \ Torque calculat \ Comp calculat |
| Max deviation         | 796  | OPTIONS \ PID \ Diameter calc                             |
| Max out voltage [V]   | 175  | START UP \ Motor data                                     |
| Max out voltage [V]   | 175  | REG PARAMETERS \ In use values                            |
| Maximum diameter [m]  | 1153 | OPTIONS \ TORQUE WINDER \ Diam Calculatio                 |
| Minimum diameter [mm] | 799  | OPTIONS \ TORQUE WINDER \ Diam Calculatio                 |
| Minimum diameter [cm] | 799  | OPTIONS \ PID \ Diameter calc                             |
| Mot cur th delay [ms] | 1431 | CURRENT REGULAT   |
| Mot cur threshld [%]  | 1430 | CURRENT REGULAT   |
| Motor current [%]     | 199  | DRIVE STATUS  |
| Motor current [%]     | 199  | MONITOR \ Measurements                                    |
| Motor current [%]     | 199  | CURRENT REGULAT   |
| Motor I2t accum       | 655  | STARTUP \ Overload contr                                  |
| Motor I2t accum       | 655  | FUNCTIONS \ Overload contr                                |
| Motor max speed [rpm] | 162  | START UP \ Motor data                                     |
| Motor max speed [rpm] | 162  | CONFIGURATION \ Speed fbk                                 |
| Motor nom flux        | 280  | START UP \ Motor data                                     |
| Motor nom flux        | 280  | FLUX REGULATION \ Flux \ if curve                         |
| Motor ovrlld preal.   | 1289 | STARTUP \ Overload contr                                  |
| Motor ovrlld preal.   | 1289 | FUNCTIONS \ Overload contr                                |
| Motor pot down        | 397  | FUNCTIONS \ Motor pot                                     |
| Motor pot oper        | 247  | FUNCTIONS \ Motor pot                                     |
| Motor pot reset       | 249  | FUNCTIONS \ Motor pot                                     |
| Motor pot sign        | 248  | FUNCTIONS \ Motor pot                                     |
| Motor pot up          | 396  | FUNCTIONS \ Motor pot                                     |
| Mul gain              | 486  | SPEC FUNCTIONS \ Links \ Link 1                           |
| Mul gain              | 555  | SPEC FUNCTIONS \ Links \ Link 2                           |
| Mul gain              | 1220 | SPEC FUNCTIONS \ Links \ Link 3                           |
| Mul gain              | 1229 | SPEC FUNCTIONS \ Links \ Link 4                           |
| Mul gain              | 1238 | SPEC FUNCTIONS \ Links \ Link 5                           |
| Mul gain              | 1247 | SPEC FUNCTIONS \ Links \ Link 6                           |
| Multi speed 1 [FF]    | 154  | FUNCTIONS \ Multi speed fct                               |
| Multi speed 2 [FF]    | 155  | FUNCTIONS \ Multi speed fct                               |
| Multi speed 3 [FF]    | 156  | FUNCTIONS \ Multi speed fct                               |
| Multi speed 4 [FF]    | 157  | FUNCTIONS \ Multi speed fct                               |
| Multi speed 5 [FF]    | 158  | FUNCTIONS \ Multi speed fct                               |
| Multi speed 6 [FF]    | 159  | FUNCTIONS \ Multi speed fct                               |
| Multi speed 7 [FF]    | 160  | FUNCTIONS \ Multi speed fct                               |
| Multispeed sel        | 208  | FUNCTIONS \ Multi speed fct                               |
| Nom flux curr [A]     | 374  | START UP  |
| Nom flux curr [A]     | 374  | FLUX REGULATION \ Flux \ if curve                         |
| Offset acc time [s]   | 1198 | OPTIONS \ TORQUE WINDER \ Speed demand                    |
| Offset input 1        | 74   | START UP \ Analog inputs \ Analog input 1                 |
| Offset input 1        | 74   | I/O CONFIG \ Analog inputs \ Analog input 1               |

| Parameter            | No.  | Position                                      |
|----------------------|------|---|
| Offset input 2       | 79   | START UP \ Analog inputs \ Analog input 2     |
| Offset input 2       | 79   | I/O CONFIG \ Analog inputs \ Analog input 2   |
| Offset input 3       | 84   | START UP \ Analog inputs \ Analog input 3     |
| Offset input 3       | 84   | I/O CONFIG \ Analog inputs \ Analog input 3   |
| Ok relay funct       | 412  | REG PARAMETERS \ In use values                |
| Ok relay open        | 195  | CONFIGURATION \ Prog alarms \ Failure supply  |
| Ok relay open        | 356  | CONFIGURATION \ Prog alarms \ External fault  |
| Ok relay open        | 358  | CONFIGURATION \ Prog alarms \ Undervoltage    |
| Ok relay open        | 362  | CONFIGURATION \ Prog alarms \ Overvoltage     |
| Ok relay open        | 364  | CONFIGURATION \ Prog alarms \ Overcurrent     |
| Ok relay open        | 367  | CONFIGURATION \ Prog alarms \ Overtemp motor  |
| Ok relay open        | 370  | CONFIGURATION \ Prog alarms \ Heatsink        |
| Ok relay open        | 387  | CONFIGURATION \ Prog alarms \ Hw opt1 failure |
| Ok relay open        | 472  | CONFIGURATION \ Prog alarms \ Field loss      |
| Ok relay open        | 477  | CONFIGURATION \ Prog alarms \ Speed fbk loss  |
| Ok relay open        | 635  | CONFIGURATION \ Prog alarms \ Bus loss        |
| Ok relay open        | 640  | CONFIGURATION \ Prog alarms \ Opt2 failure    |
| Ok relay open        | 730  | CONFIGURATION \ Prog alarms \ Enable seq err  |
| Ok relay open        | 1297 | CONFIGURATION \ Prog alarms \ Brake fault     |
| Ok relay open        | 1423 | CONFIGURATION \ Prog alarms \ Overspeed       |
| Ok relay open        | 1434 | CONFIGURATION \ Prog alarms \ Delta frequency |
| Ok relay open        | 1420 | CONFIGURATION \ Prog alarms \ Motor I2t ovrl  |
| Ok relay open        | 1441 | CONFIGURATION \ Prog alarms \ Drive I2t ovrl  |
| Out vlt level        | 921  | FLUX REGULATION                               |
| Output offset        | 491  | SPEC FUNCTIONS \ Links \ Link 1               |
| Output offset        | 560  | SPEC FUNCTIONS \ Links \ Link 2               |
| Output offset        | 1225 | SPEC FUNCTIONS \ Links \ Link 3               |
| Output offset        | 1234 | SPEC FUNCTIONS \ Links \ Link 4               |
| Output offset        | 1243 | SPEC FUNCTIONS \ Links \ Link 5               |
| Output offset        | 1252 | SPEC FUNCTIONS \ Links \ Link 6               |
| Output power [kW]    | 1052 | DRIVE STATUS                                  |
| Output power [Kw]    | 1052 | MONITOR \ Measurements                        |
| Output voltage [V]   | 233  | DRIVE STATUS                                  |
| Output voltage [V]   | 233  | MONITOR \ Measurements                        |
| Overcurrent thr [%]  | 584  | START UP \ Alarms                             |
| Overcurrent thr [%]  | 584  | CONFIGURATION \ Prog alarms \ Overcurrent     |
| Overld available     | 406  | FUNCTIONS \ Overload contr                    |
| Overload current [%] | 312  | START UP \ Overload contr                     |
| Overload current [%] | 312  | FUNCTIONS \ Overload contr                    |
| Overload mode        | 318  | START UP \ Overload contr                     |
| Overload mode        | 318  | FUNCTIONS \ Overload contr                    |
| Overload state       | 407  | FUNCTIONS \ Overload contr                    |
| Overload time [s]    | 310  | START UP \ Overload contr                     |
| Overload time [s]    | 310  | FUNCTIONS \ Overload contr                    |
| Overspeed thr [rpm]  | 1426 | CONFIGURATION \ Prog alarms \ Overspeed       |
| P init gain PID      | 793  | OPTIONS \ PID \ PI controls                   |
| Pad 0                | 503  | SPEC FUNCTIONS \ Pad Parameters               |
| Pad 1                | 504  | SPEC FUNCTIONS \ Pad Parameters               |
| Pad 10               | 513  | SPEC FUNCTIONS \ Pad Parameters               |
| Pad 11               | 514  | SPEC FUNCTIONS \ Pad Parameters               |
| Pad 12               | 515  | SPEC FUNCTIONS \ Pad Parameters               |
| Pad 13               | 516  | SPEC FUNCTIONS \ Pad Parameters               |
| Pad 14               | 517  | SPEC FUNCTIONS \ Pad Parameters               |
| Pad 15               | 518  | SPEC FUNCTIONS \ Pad Parameters               |
| Pad 2                | 505  | SPEC FUNCTIONS \ Pad Parameters               |
| Pad 3                | 506  | SPEC FUNCTIONS \ Pad Parameters               |
| Pad 4                | 507  | SPEC FUNCTIONS \ Pad Parameters               |

| Parameter            | No. | Position                        |
|----------------------|-----|---------------------------------|
| Pad 5                | 508 | SPEC FUNCTIONS \ Pad Parameters |
| Pad 6                | 509 | SPEC FUNCTIONS \ Pad Parameters |
| Pad 7                | 510 | SPEC FUNCTIONS \ Pad Parameters |
| Pad 8                | 511 | SPEC FUNCTIONS \ Pad Parameters |
| Pad 9                | 512 | SPEC FUNCTIONS \ Pad Parameters |
| Pad A Bit 0          | 520 | SPEC FUNCTIONS \ Pad Parameters |
| Pad A Bit 1          | 521 | SPEC FUNCTIONS \ Pad Parameters |
| Pad A Bit 10         | 530 | SPEC FUNCTIONS \ Pad Parameters |
| Pad A Bit 11         | 531 | SPEC FUNCTIONS \ Pad Parameters |
| Pad A Bit 12         | 532 | SPEC FUNCTIONS \ Pad Parameters |
| Pad A Bit 13         | 533 | SPEC FUNCTIONS \ Pad Parameters |
| Pad A Bit 14         | 534 | SPEC FUNCTIONS \ Pad Parameters |
| Pad A Bit 15         | 535 | SPEC FUNCTIONS \ Pad Parameters |
| Pad A Bit 2          | 522 | SPEC FUNCTIONS \ Pad Parameters |
| Pad A Bit 3          | 523 | SPEC FUNCTIONS \ Pad Parameters |
| Pad A Bit 4          | 524 | SPEC FUNCTIONS \ Pad Parameters |
| Pad A Bit 5          | 525 | SPEC FUNCTIONS \ Pad Parameters |
| Pad A Bit 6          | 526 | SPEC FUNCTIONS \ Pad Parameters |
| Pad A Bit 7          | 527 | SPEC FUNCTIONS \ Pad Parameters |
| Pad A Bit 8          | 528 | SPEC FUNCTIONS \ Pad Parameters |
| Pad A Bit 9          | 529 | SPEC FUNCTIONS \ Pad Parameters |
| Pad B Bit 0          | 537 | SPEC FUNCTIONS \ Pad Parameters |
| Pad B Bit 1          | 538 | SPEC FUNCTIONS \ Pad Parameters |
| Pad B Bit 10         | 547 | SPEC FUNCTIONS \ Pad Parameters |
| Pad B Bit 11         | 548 | SPEC FUNCTIONS \ Pad Parameters |
| Pad B Bit 12         | 549 | SPEC FUNCTIONS \ Pad Parameters |
| Pad B Bit 13         | 550 | SPEC FUNCTIONS \ Pad Parameters |
| Pad B Bit 14         | 551 | SPEC FUNCTIONS \ Pad Parameters |
| Pad B Bit 15         | 552 | SPEC FUNCTIONS \ Pad Parameters |
| Pad B Bit 2          | 539 | SPEC FUNCTIONS \ Pad Parameters |
| Pad B Bit 3          | 540 | SPEC FUNCTIONS \ Pad Parameters |
| Pad B Bit 4          | 541 | SPEC FUNCTIONS \ Pad Parameters |
| Pad B Bit 5          | 542 | SPEC FUNCTIONS \ Pad Parameters |
| Pad B Bit 6          | 543 | SPEC FUNCTIONS \ Pad Parameters |
| Pad B Bit 7          | 544 | SPEC FUNCTIONS \ Pad Parameters |
| Pad B Bit 8          | 545 | SPEC FUNCTIONS \ Pad Parameters |
| Pad B Bit 9          | 546 | SPEC FUNCTIONS \ Pad Parameters |
| Password 2           |     | SERVICE                         |
| Pause time [s]       | 311 | START UP \ Overload contr       |
| Pause time [s]       | 311 | FUNCTIONS \ Overload contr      |
| PD D filter PID [ms] | 767 | OPTIONS \ PID \ PD control      |
| PD D gain 1 PID [%]  | 766 | OPTIONS \ PID \ PD control      |
| PD D gain 2 PID [%]  | 789 | OPTIONS \ PID \ PD control      |
| PD D gain 3 PID [%]  | 791 | OPTIONS \ PID \ PD control      |
| PD output PID        | 421 | OPTIONS \ PID \ PD control      |
| PD P gain 1 PID [%]  | 768 | OPTIONS \ PID \ PD control      |
| PD P gain 2 PID [%]  | 788 | OPTIONS \ PID \ PD control      |
| PD P gain 3 PID [%]  | 790 | OPTIONS \ PID \ PD control      |
| Percent ref var [%]  | 116 | DRIVECOM                        |
| PI bottom lim        | 785 | OPTIONS \ PID \ PI controls     |
| PI central v sel     | 779 | OPTIONS \ PID \ PI controls     |
| PI central v1        | 776 | OPTIONS \ PID \ PI controls     |
| PI central v2        | 777 | OPTIONS \ PID \ PI controls     |
| PI central v3        | 778 | OPTIONS \ PID \ PI controls     |
| PI central vs0       | 780 | OPTIONS \ PID                   |
| PI central vs1       | 781 | OPTIONS \ PID                   |
| PI I gain PID        | 764 | OPTIONS \ PID \ PI controls     |



| Parameter             | No.  | Position   |
|-----------------------|------|--|
| PI integr freeze      | 783  | OPTIONS \ PID \ PI controls                          |
| PI output PID         | 771  | OPTIONS \ PID \ PI controls                          |
| PI P gain PID         | 765  | OPTIONS \ PID \ PI controls                          |
| PI steady delay       | 731  | OPTIONS \ PID \ PI controls                          |
| PI steady thr         | 695  | OPTIONS \ PID \ PI controls                          |
| PI top lim            | 784  | OPTIONS \ PID \ PI controls                          |
| PID acc time          | 1046 | OPTIONS \ PID \ PID references                       |
| PID clamp             | 757  | OPTIONS \ PID \ PID references                       |
| PID dec time          | 1047 | OPTIONS \ PID \ PID references                       |
| PID error             | 759  | OPTIONS \ PID \ PID references                       |
| PID feed-back         | 763  | OPTIONS \ PID \ PID references                       |
| PID offs. Sel         | 762  | OPTIONS \ PID \ PID references                       |
| PID offset 0          | 760  | OPTIONS \ PID \ PID references                       |
| PID offset 1          | 761  | OPTIONS \ PID \ PID references                       |
| PID out scale         | 773  | OPTIONS \ PID \ PID target                           |
| PID out sign PID      | 772  | OPTIONS \ PID \ PD control                           |
| PID output            | 774  | OPTIONS \ PID \ PD control                           |
| PID source            | 786  | OPTIONS \ PID \ PID source                           |
| PID source gain       | 787  | OPTIONS \ PID \ PID source                           |
| PID target            | 782  | OPTIONS \ PID \ PID target                           |
| Positioning spd [rpm] | 795  | OPTIONS \ PID \ Diameter calc                        |
| Prop filter [ms]      | 444  | TUNING   |
| Prop filter [ms]      | 444  | SPEED REGULAT  |
| Pword 1               | 85   | CONFIGURATION  |
| QStp delta speed [FF] | 37   | RAMP \ Quick stop                                    |
| QStp delta speed [FF] | 37   | DRIVECOM \ Quick stop                                |
| QStp delta time [s]   | 38   | RAMP \ Quick stop                                    |
| QStp delta time [s]   | 38   | DRIVECOM \ Quick stop                                |
| Quick stop            | 343  | -  |
| Quick stop            | 343  | DRIVECOM \ Quick stop                                |
| R&L Search            | 452  | START UP   |
| R&L Search            | 452  | TUNING   |
| R&L Search            | 452  | CURRENT REGULAT                                      |
| Ramp -                | 347  | RAMP   |
| Ramp +                | 346  | RAMP   |
| Ramp +/- delay [ms]   | 20   | RAMP   |
| Ramp in = 0           | 345  | RAMP   |
| Ramp out = 0          | 344  | RAMP   |
| Ramp outp (rpm)       | 113  | MONITOR \ Measurements \ Speed \ Speed in rpm        |
| Ramp output (%)       | 114  | MONITOR \ Measurements \ Speed \ Speed in %          |
| Ramp output (d) [FF]  | 112  | MONITOR \ Measurements \ Speed \ Speed in DRC [ ]    |
| Ramp ref (%)          | 111  | MONITOR \ Measurements \ Speed \ Speed in %          |
| Ramp ref (d) [FF]     | 109  | MONITOR \ Measurements \ Speed \ Speed in DRC [ ]    |
| Ramp ref (rpm)        | 110  | MONITOR \ Measurements \ Speed \ Speed in rpm        |
| Ramp ref 1 (%)        | 47   | INPUT VARIABLES \ Ramp ref \ Ramp ref 1              |
| Ramp ref 1 [FF]       | 44   | DRIVE STATUS   |
| Ramp ref 1 [FF]       | 44   | INPUT VARIABLES \ Ramp ref \ Ramp ref 1              |
| Ramp ref 2 (%)        | 49   | INPUT VARIABLES \ Ramp ref \ Ramp ref 2              |
| Ramp ref 2 [FF]       | 48   | INPUT VARIABLES \ Ramp ref \ Ramp ref 2              |
| Ramp sel 0            | 403  | FUNCTIONS \ Multi ramp fct \ Ramp 3 \ Deceleration 3 |
| Ramp sel 1            | 404  | FUNCTIONS \ Multi ramp fct \ Ramp 3 \ Deceleration 3 |
| Ramp selector         | 202  | FUNCTIONS \ Multi ramp fct                           |
| Ramp shape            | 18   | RAMP   |
| Real FF PID           | 418  | OPTIONS \ PID \ PI controls                          |
| Ref 0 level [FF]      | 106  | SPEED REGULAT \ Spd zero logic                       |
| Ref line speed [%]    | 1286 | OPTIONS \ TORQUE WINDER \ Diam Calculatio            |
| Ref spd source        | 1284 | OPTIONS \ TORQUE WINDER \ Diam Calculatio            |

| Parameter            | No.  | Position   |
|----------------------|------|--|
| Ref speed gain       | 1285 | OPTIONS \ TORQUE WINDER \ Diam Calculatio            |
| Ref speed thr [%]    | 1155 | OPTIONS \ TORQUE WINDER \ Diam Calculatio            |
| Refresh enc 1        | 649  | CONFIGURATION \ Speed fbk                            |
| Refresh enc 1        | 649  | I/O CONFIG \ Encoder inputs                          |
| Refresh enc 2        | 652  | START UP \ Speed feedback                            |
| Refresh enc 2        | 652  | CONFIGURATION \ Speed fbk                            |
| Refresh enc 2        | 652  | I/O CONFIG \ Encoder inputs                          |
| Relay 2              | 629  | I/O CONFIG \ Digital outputs                         |
| Reset flux / if      | 920  | FLUX REGULATION \ Flux \ if curve                    |
| Restart time [ms]    | 359  | CONFIGURATION \ Prog alarms \ Undervoltage           |
| Restart time [ms]    | 474  | CONFIGURATION \ Prog alarms \ Field loss             |
| Restart time [ms]    | 483  | CONFIGURATION \ Prog alarms \ Overvoltage            |
| Restart time [ms]    | 501  | CONFIGURATION \ Prog alarms \ External fault         |
| Restart time [ms]    | 585  | CONFIGURATION \ Prog alarms \ Overcurrent            |
| Restart time [ms]    | 637  | CONFIGURATION \ Prog alarms \ Bus loss               |
| Restart time [ms]    | 1425 | CONFIGURATION \ Prog alarms \ Overspeed              |
| Restart time [ms]    | 1436 | CONFIGURATION \ Prog alarms \ Delta frequency        |
| Reverse sign         | 294  | RAMP   |
| Roll diameter [m]    | 1154 | OPTIONS \ TORQUE WINDER \ Diam Calculatio            |
| S acc t const [ms]   | 663  | RAMP   |
| S acc t const 0 [ms] | 665  | FUNCTIONS \ Multi ramp fct \ Ramp 0 \ Acceleration 0 |
| S acc t const 1 [ms] | 667  | FUNCTIONS \ Multi ramp fct \ Ramp 1 \ Acceleration 1 |
| S acc t const 2 [ms] | 669  | FUNCTIONS \ Multi ramp fct \ Ramp 2 \ Acceleration 2 |
| S acc t const 3 [ms] | 671  | FUNCTIONS \ Multi ramp fct \ Ramp 3 \ Acceleration 3 |
| S dec t const [ms]   | 664  | RAMP   |
| S dec t const 0 [ms] | 666  | FUNCTIONS \ Multi ramp fct \ Ramp 0 \ Deceleration 0 |
| S dec t const 1 [ms] | 668  | FUNCTIONS \ Multi ramp fct \ Ramp 1 \ Deceleration 1 |
| S dec t const 2 [ms] | 670  | FUNCTIONS \ Multi ramp fct \ Ramp 2 \ Deceleration 2 |
| S dec t const 3 [ms] | 672  | FUNCTIONS \ Multi ramp fct \ Ramp 3 \ Deceleration 3 |
| S shape t const [ms] | 19   | RAMP   |
| Save parameters      | 256  | START UP   |
| Save parameters      | 256  | TUNING   |
| Save parameters      | 256  | SPEC FUNCTIONS                                       |
| Scale input 1        | 72   | START UP \ Analog inputs \ Analog input 1            |
| Scale input 1        | 72   | I/O CONFIG \ Analog inputs \ Analog input 1          |
| Scale input 2        | 77   | START UP \ Analog inputs \ Analog input 2            |
| Scale input 2        | 77   | I/O CONFIG \ Analog inputs \ Analog input 2          |
| Scale input 3        | 82   | START UP \ Analog inputs \ Analog input 3            |
| Scale input 3        | 82   | I/O CONFIG \ Analog inputs \ Analog input 3          |
| Scale output 1       | 62   | I/O CONFIG \ Analog outputs \ Analog output 1        |
| Scale output 2       | 63   | I/O CONFIG \ Analog outputs \ Analog output 2        |
| Scale output 3       | 64   | I/O CONFIG \ Analog outputs \ Analog output 3        |
| Scale output 4       | 65   | I/O CONFIG \ Analog outputs \ Analog output 4        |
| Select adap type     | 182  | ADD SPEED FUNCT \ Adaptive spd reg                   |
| Select enc 1         | 1020 | I/O CONFIG \ Encoder inputs                          |
| Select enc 2         | 1021 | I/O CONFIG \ Encoder inputs                          |
| Select input 1       | 70   | START UP \ Analog inputs \ Analog input 1            |
| Select input 1       | 70   | I/O CONFIG \ Analog inputs \ Analog input 1          |
| Select input 2       | 75   | START UP \ Analog inputs \ Analog input 2            |
| Select input 2       | 75   | I/O CONFIG \ Analog inputs \ Analog input 2          |
| Select input 3       | 80   | START UP \ Analog inputs \ Analog input 3            |
| Select input 3       | 80   | I/O CONFIG \ Analog inputs \ Analog input 3          |
| Select output 1      | 66   | I/O CONFIG \ Analog outputs \ Analog output 1        |
| Select output 2      | 67   | I/O CONFIG \ Analog outputs \ Analog output 2        |
| Select output 3      | 68   | I/O CONFIG \ Analog outputs \ Analog output 3        |
| Select output 4      | 69   | I/O CONFIG \ Analog outputs \ Analog output 4        |
| Ser answer delay     | 408  | CONFIGURATION \ Set serial comm                      |

| Parameter               | No.  | Position  |
|-------------------------|------|---|
| Ser baudrate sel        | 326  | CONFIGURATION \ Set serial comm                   |
| Ser protocol sel        | 323  | CONFIGURATION \ Set serial comm                   |
| Set delay [ms]          | 105  | ADD SPEED FUNCT \ Speed control                   |
| Set error [FF]          | 104  | ADD SPEED FUNCT \ Speed control                   |
| Set flux / if           | 919  | FLUX REGULATION \ Flux \ if curve                 |
| Set speed               | 394  | ADD SPEED FUNCT \ Speed control                   |
| Size selection          | 464  | CONFIGURATION \ Drive type                        |
| Software version        | 331  | CONFIGURATION \ Drive type                        |
| Source                  | 484  | SPEC FUNCTIONS \ Links \ Link 1                   |
| Source                  | 553  | SPEC FUNCTIONS \ Links \ Link 2                   |
| Source                  | 1218 | SPEC FUNCTIONS \ Links \ Link 3                   |
| Source                  | 1227 | SPEC FUNCTIONS \ Links \ Link 4                   |
| Source                  | 1236 | SPEC FUNCTIONS \ Links \ Link 5                   |
| Source                  | 1245 | SPEC FUNCTIONS \ Links \ Link 6                   |
| Spd 0 trip delay [ms]   | 627  | FUNCTIONS \ Stop control                          |
| Spd match acc [s]       | 1196 | OPTIONS \ TORQUE WINDER \ Speed demand            |
| Spd match compl         | 1203 | OPTIONS \ TORQUE WINDER \ Speed demand            |
| Spd match dec [s]       | 1197 | OPTIONS \ TORQUE WINDER \ Speed demand            |
| Spd match gain [%]      | 1200 | OPTIONS \ TORQUE WINDER \ Speed demand            |
| Spd match torque [%]    | 1216 | OPTIONS \ TORQUE WINDER \ Speed demand            |
| Spd threshold           | 393  | ADD SPEED FUNCT \ Speed control                   |
| Spd threshold - [FF]    | 102  | ADD SPEED FUNCT \ Speed control                   |
| Spd threshold + [FF]    | 101  | ADD SPEED FUNCT \ Speed control                   |
| Spd=0 P gain [%]        | 126  | SPEED REGULAT \ Spd zero logic                    |
| Speed base value [FF]   | 45   | START UP  |
| Speed base value [FF]   | 45   | REG PARAMETERS \ In use values                    |
| Speed base value [FF]   | 45   | DRIVECOM  |
| Speed demand En         | 1215 | OPTIONS \ TORQUE WINDER \ Speed demand            |
| Speed draw out (%)      | 1019 | FUNCTIONS \ Speed draw                            |
| Speed draw out (d)      | 1018 | FUNCTIONS \ Speed draw                            |
| Speed fbk error [%]     | 455  | CONFIGURATION \ Speed fbk                         |
| Speed fbk sel           | 414  | START UP \ Speed feedback                         |
| Speed fbk sel           | 414  | CONFIGURATION \ Speed fbk                         |
| Speed I [%]             | 88   | START UP \ Speed self tune                        |
| Speed I [%]             | 88   | TUNING \ Speed self tune                          |
| Speed I [%]             | 88   | TUNING  |
| Speed I [%]             | 88   | SPEED REGULAT. \ Self tuning                      |
| Speed I [%]             | 88   | REG PARAMETERS \ Percent values \ Speed regulator |
| Speed I base [A/rpm.ms] | 94   | REG PARAMETERS \ Base values \ Speed regulator    |
| Speed I bypass [%]      | 460  | REG PARAMETERS \ Percent values \ Speed regulator |
| Speed I in use [%]      | 100  | REG PARAMETERS \ In use values                    |
| Speed I Nw [%]          | 1033 | START UP \ Speed self tune                        |
| Speed I Nw [%]          | 1033 | TUNING \ Speed self tune                          |
| Speed I Nw [%]          | 1033 | SPEED REGULAT. \ Self tuning                      |
| Speed input perc [%]    | 46   | DRIVECOM  |
| Speed input var [FF]    | 44   | DRIVECOM  |
| Speed limited           | 372  | LIMITS \ Speed limits \ Speed min/max             |
| Speed match             | 1195 | OPTIONS \ TORQUE WINDER \ Speed demand            |
| Speed max amount [FF]   | 2    | START UP \ Limits                                 |
| Speed max amount [FF]   | 2    | LIMITS \ Speed limits \ Speed amount              |
| Speed max amount [FF]   | 2    | DRIVECOM \ Speed amount                           |
| Speed max neg [FF]      | 4    | LIMITS \ Speed limits \ Speed min/max             |
| Speed max neg [FF]      | 4    | DRIVECOM \ Speed min/max                          |
| Speed max pos [FF]      | 3    | LIMITS \ Speed limits \ Speed min/max             |
| Speed max pos [FF]      | 3    | DRIVECOM \ Speed min/max                          |
| Speed min amount [FF]   | 1    | START UP \ Limits                                 |
| Speed min amount [FF]   | 1    | LIMITS \ Speed limits \ Speed amount              |

| Parameter             | No.  | Position  |
|-----------------------|------|---|
| Speed min amount [FF] | 1    | DRIVECOM \ Speed amount                                   |
| Speed min neg [FF]    | 6    | LIMITS \ Speed limits \ Speed min/max                     |
| Speed min neg [FF]    | 6    | DRIVECOM \ Speed min/max                                  |
| Speed min pos [FF]    | 5    | LIMITS \ Speed limits \ Speed min/max                     |
| Speed min pos [FF]    | 5    | DRIVECOM \ Speed min/max                                  |
| Speed offset          | 563  | START UP \ Speed feedback                                 |
| Speed offset          | 563  | CONFIGURATION \ Speed fbk                                 |
| Speed P [%]           | 87   | START UP \ Speed self tune                                |
| Speed P [%]           | 87   | TUNING \ Speed self tune                                  |
| Speed P [%]           | 87   | TUNING  |
| Speed P [%]           | 87   | SPEED REGULAT. \ Self tuning                              |
| Speed P [%]           | 87   | REG PARAMETERS \ Percent values \ Speed regulator         |
| Speed P base [A/rpm]  | 93   | REG PARAMETERS \ Base values \ Speed regulator            |
| Speed P bypass [%]    | 459  | REG PARAMETERS \ Percent values \ Speed regulator         |
| Speed P in use [%]    | 99   | REG PARAMETERS \ In use values                            |
| Speed P Nw [%]        | 1032 | START UP \ Speed self tune                                |
| Speed P Nw [%]        | 1032 | TUNING \ Speed self tune                                  |
| Speed P Nw [%]        | 1032 | SPEED REGULAT. \ Self tuning                              |
| Speed ratio           | 1017 | FUNCTIONS \ Speed draw                                    |
| Speed ref (%)         | 117  | MONITOR \ Measurements \ Speed \ Speed in %               |
| Speed ref (d) [FF]    | 115  | MONITOR \ Measurements \ Speed \ Speed in DRC [ ]         |
| Speed ref (rpm)       | 118  | DRIVE STATUS  |
| Speed ref (rpm)       | 118  | MONITOR \ Measurements \ Speed \ Speed in rpm             |
| Speed ref [rpm]       | 118  | SPEED REGULAT   |
| Speed ref 1 (%)       | 378  | INPUT VARIABLES \ Speed ref \ Speed ref 1                 |
| Speed ref 1 [FF]      | 42   | INPUT VARIABLES \ Speed ref \ Speed ref 1                 |
| Speed Ref 2 (%)       | 379  | INPUT VARIABLES \ Speed ref \ Speed ref 2                 |
| Speed ref 2 [FF]      | 43   | INPUT VARIABLES \ Speed ref \ Speed ref 2                 |
| Speed ref var [FF]    | 115  | DRIVECOM  |
| Speed reg output [% ] | 236  | SPEED REGULAT   |
| Speed sel 0           | 400  | FUNCTIONS \ Multi speed fct                               |
| Speed sel 1           | 401  | FUNCTIONS \ Multi speed fct                               |
| Speed sel 2           | 402  | FUNCTIONS \ Multi speed fct                               |
| Speed up base [ms]    | 446  | SPEED REGULAT \ Speed up                                  |
| Speed up filter [ms]  | 447  | SPEED REGULAT \ Speed up                                  |
| Speed up gain [%]     | 445  | SPEED REGULAT \ Speed up                                  |
| Speed zero delay [ms] | 108  | ADD SPEED FUNCT \ Speed zero                              |
| Speed zero level [FF] | 107  | ADD SPEED FUNCT \ Speed zero                              |
| Speed zero thr        | 395  | ADD SPEED FUNCT \ Speed zero                              |
| Speed-0 f weak        | 499  | START UP  |
| Speed-0 f weak        | 499  | FLUX REGULATION   |
| Start                 | 1027 | START UP \ Speed self tune                                |
| Start                 | 1027 | TUNING \ Speed self tune                                  |
| Start                 | 1027 | SPEED REGULAT. \ Self tuning                              |
| Start/Stop            | 315  | -   |
| Start/Stop            | 315  | DRIVE STATUS  |
| Start/Stop            | 315  | START UP  |
| Start/Stop            | 315  | TUNING  |
| Start/Stop            | 315  | MONITOR   |
| Static f [%]          | 1174 | OPTIONS \ TORQUE WINDER \ Torque calculat \ Comp calculat |
| Static f Zero         | 1287 | OPTIONS \ TORQUE WINDER \ Torque calculat \ Comp calculat |
| Status word           | 56   | DRIVECOM  |
| Stop mode             | 626  | FUNCTIONS \ Stop control                                  |
| T curr filter [s]     | 926  | MONITOR \ Measurements                                    |
| T current lim - [%]   | 9    | LIMITS \ Current limits                                   |
| T current lim [%]     | 7    | START UP \ Limits   |
| T current lim [%]     | 7    | LIMITS \ Current limits                                   |

| Parameter                | No.  | Position   |
|--------------------------|------|--|
| T current lim + [%]      | 8    | LIMITS \ Current limits                                    |
| T current lim type       | 715  | LIMITS \ Current limits                                    |
| T current ref [%]        | 41   | MONITOR \ Measurements                                     |
| T current ref [%]        | 41   | CURRENT REGULAT  |
| T current ref 1 [%]      | 39   | INPUT VARIABLES \ T current ref                            |
| T current ref 2 [%]      | 40   | INPUT VARIABLES \ T current ref                            |
| Tacho scale              | 562  | START UP \ Speed feedback                                  |
| Tacho scale              | 562  | CONFIGURATION \ Speed fbk                                  |
| Take val                 | 1028 | START UP \ Speed self tune                                 |
| Take val                 | 1028 | TUNING \ Speed self tune                                   |
| Take val                 | 1028 | SPEED REGULAT. \ Self tuning                               |
| Taper enable             | 1176 | OPTIONS \ TORQUE WINDER \ Torque calculat \ Taper function |
| Tapered speed [rpm]      | 756  | FUNCTIONS \ Taper curr lim                                 |
| Tension red [%]          | 1179 | OPTIONS \ TORQUE WINDER \ Torque calculat \ Taper function |
| Tension ref [%]          | 1180 | OPTIONS \ TORQUE WINDER \ Torque calculat                  |
| Tension ref [%]          | 1180 | OPTIONS \ TORQUE WINDER \ Torque calculat \ Taper function |
| Tension scale [%]        | 1181 | OPTIONS \ TORQUE WINDER \ Torque calculat                  |
| Test T curr lim [%]      | 1048 | START UP \ Speed self tune                                 |
| Test T curr lim [%]      | 1048 | TUNING \ Speed self tune                                   |
| Test T curr lim [%]      | 1048 | SPEED REGULAT. \ Self tuning                               |
| Threshold delay [ms]     | 103  | ADD SPEED FUNCT \ Speed control                            |
| Time acc/dec min [s]     | 1182 | OPTIONS \ TORQUE WINDER \ Torque calculat \ Comp calculat  |
| Torque const [N*m/A]     | 1013 | SPEED REGULAT \ Inertia/loss cp                            |
| Torque current [%]       | 1193 | OPTIONS \ TORQUE WINDER \ Torque calculat                  |
| Torque delay [ms]        | 1293 | FUNCTIONS \ Brake control                                  |
| Torque proving [%]       | 1294 | FUNCTIONS \ Brake control                                  |
| Torque reduct            | 342  | LIMITS \ Current limits                                    |
| Torque winder En         | 1209 | OPTIONS \ TORQUE WINDER                                    |
| Trip cont delay [ms]     | 628  | FUNCTIONS \ Stop control                                   |
| Tune value inp 1         | 73   | I/O CONFIG \ Analog inputs \ Analog input 1                |
| Tune value inp 2         | 78   | I/O CONFIG \ Analog inputs \ Analog input 2                |
| Tune value inp 3         | 83   | I/O CONFIG \ Analog inputs \ Analog input 3                |
| Undervolt thr [V]        | 481  | START UP \ Alarms  |
| Undervolt thr [V]        | 481  | CONFIGURATION \ Prog alarms \ Undervoltage                 |
| Variable J comp [%]      | 1171 | OPTIONS \ TORQUE WINDER \ Torque calculat \ Comp calculat  |
| Virtual dig inp          | 582  | MONITOR \ I/O  |
| Virtual dig out          | 583  | MONITOR \ I/O  |
| Voltage I [%]            | 494  | TUNING   |
| Voltage I [%]            | 494  | REG PARAMETERS \ Percent values \ Voltage reg              |
| Voltage I base [f%/V.ms] | 496  | REG PARAMETERS \ Base values \ Voltage reg                 |
| Voltage P [%]            | 493  | TUNING   |
| Voltage P [%]            | 493  | REG PARAMETERS \ Percent values \ Voltage reg              |
| Voltage P base [f%/V]    | 495  | REG PARAMETERS \ Base values \ Voltage reg                 |
| W gain [%]               | 1202 | OPTIONS \ TORQUE WINDER \ Speed demand                     |
| W offset [rpm]           | 1199 | OPTIONS \ TORQUE WINDER \ Speed demand                     |
| W reference [rpm]        | 1217 | OPTIONS \ TORQUE WINDER \ Speed demand                     |
| W target                 | 1210 | OPTIONS \ TORQUE WINDER \ Speed demand                     |
| Wind/unwind              | 1187 | OPTIONS \ TORQUE WINDER \ Diam Calculatio                  |
| Winder side              | 1201 | OPTIONS \ TORQUE WINDER \ Speed demand                     |
| Zero torque              | 353  | CURRENT REGULAT  |





## 10.4 LIST OF HIGH PRIORITY PARAMETERS

When a APC200 is used a subset of the TPD32 parameters can be exchanged with the optional card through the automatic synchronous communication. For more details see the APC200 technical documentation.

| Parameter                        | No. | Format | Value         |                    |          | Read/<br>Write |
|----------------------------------|-----|--------|---------------|--------------------|----------|----------------|
|                                  |     |        | min           | max                | factory  |                |
| T current lim + [CURR]           | 8   | U16    | 0             | 2 * TOP_CURR       | TOP_CURR | R/W            |
| T current lim - [CURR]           | 9   | U16    | 0             | 2 * TOP_CURR       | TOP_CURR | R/W            |
| In use Teur lim+ [CURR]          | 10  | U16    | 0             | 2 * TOP_CURR       | -        | R              |
| In use Teur lim- [CURR]          | 11  | U16    | 0             | 2 * TOP_CURR       | -        | R              |
| Current lim red [CURR]           | 13  | U16    | 0             | 2 * TOP_CURR       | TOP_CURR | R              |
| T current ref 1 [CURR]           | 39  | I16    | -2 * TOP_CURR | +2 * TOP_CURR      | 0        | R/W            |
| T current ref 2 [CURR]           | 40  | I16    | -2 * TOP_CURR | +2 * TOP_CURR      | 0        | R/W            |
| T current ref [CURR]             | 41  | I16    | -2 * TOP_CURR | +2 * TOP_CURR      | -        | R              |
| Speed ref 1 [SPD]                | 42  | I16    | -32767        | 32767              | 0        | R/W            |
| Speed ref 2 [SPD]                | 43  | I16    | -32767        | 32767              | 0        | R/W            |
| Ramp ref 1 [SPD]                 | 44  | I16    | -32767        | 32767              | 0        | R/W            |
| Ramp ref 2 [SPD]                 | 48  | I16    | -32767        | 32767              | 0        | R/W            |
| Control word                     | 55  | U16    |               |                    |          | R/W            |
| Status word                      | 56  | U16    |               |                    |          | R              |
| Ramp ref [SPD]                   | 110 | I16    | -32767        | 32767              | -        | R              |
| Ramp outp [SPD]                  | 113 | I16    | -32767        | 32767              | -        | R              |
| Speed ref [SPD]                  | 118 | I16    | -32767        | 32767              | -        | R              |
| Actual spd [SPD]                 | 122 | I16    | -32767        | 32767              | -        | R              |
| Adap reference [SPD]             | 183 | I16    | -32767        | 32767              | 4000     | R/W            |
| Enc 1 position [ENC_PLS] *       | 197 | I16    | -32767        | 32767              | -        | R              |
| Enc 2 position [ENC_PLS] *       | 198 | I16    | -32767        | 32767              | -        | R              |
| Enc 1 last time [ENC_TIM] *      | 204 | U32    | 0             | 2 <sup>32</sup> -1 | -        | R              |
| Enc 1 last time high [ENC_TIM] * | 205 | U16    | 0             | 65535              | -        | R              |
| Enc 2 last time [ENC_TIM] *      | 206 | U32    | 0             | 2 <sup>32</sup> -1 | -        | R              |
| Enc 2 last time high [ENC_TIM] * | 207 | U16    | 0             | 65535              | -        | R              |
| Speed reg output [CURR]          | 236 | I16    | -2 * TOP_CURR | +2 * TOP_CURR      | -        | R              |
| Lock speed reg                   | 322 | U16    | 0             | 1                  | 0        | R/W            |
| Enc 2 speed [SPD] *              | 420 | I16    | -37767        | 32767              | -        | R              |
| Enc 1 speed [SPD] *              | 427 | I16    | -37767        | 32767              | -        | R              |
| Flux current max                 | 467 | U16    | 819           | 16384              | 16384    | R/W            |
| Flux reference                   | 500 | U16    | 0             | 16384              | 16384    | R              |
| Pad 0                            | 503 | I16    | -32768        | 32767              | 0        | R/W            |
| Pad 1                            | 504 | I16    | -32768        | 32767              | 0        | R/W            |
| Pad 2                            | 505 | I16    | -32768        | 32767              | 0        | R/W            |
| Pad 3                            | 506 | I16    | -32768        | 32767              | 0        | R/W            |
| Pad 4                            | 507 | I16    | -32768        | 32767              | 0        | R/W            |
| Pad 5                            | 508 | I16    | -32768        | 32767              | 0        | R/W            |
| Pad 6                            | 509 | I16    | -32768        | 32767              | 0        | R/W            |
| Pad 7                            | 510 | I16    | -32768        | 32767              | 0        | R/W            |
| Pad 8                            | 511 | I16    | -32768        | 32767              | 0        | R/W            |
| Pad 9                            | 512 | I16    | -32768        | 32767              | 0        | R/W            |
| Pad 10                           | 513 | I16    | -32768        | 32767              | 0        | R/W            |
| Pad 11                           | 514 | I16    | -32768        | 32767              | 0        | R/W            |
| Pad 12                           | 515 | I16    | -32768        | 32767              | 0        | R/W            |
| Pad 13                           | 516 | I16    | -32768        | 32767              | 0        | R/W            |
| Pad 14                           | 517 | I16    | -32768        | 32767              | 0        | R/W            |
| Pad 15                           | 518 | I16    | -32768        | 32767              | 0        | R/W            |
| Bitword pad A                    | 519 | U16    | 0             | 65535              | 0        | R/W            |
| Bitword pad B                    | 536 | U16    | 0             | 65535              | 0        | R/W            |
| Dig input term                   | 564 | U16    | 0             | 65535              | 0        | R              |
| Dig output term                  | 581 | U16    | 0             | 65535              | 0        | R              |

|                         |      |     |               |                     |        |     |
|-------------------------|------|-----|---------------|---------------------|--------|-----|
| Load comp [CURR]        | 698  | I16 | -2 * TOP_CURR | +2 * TOP_CURR       | -      | R   |
| Ind store ctrl          | 912  | U16 | 0             | 65535               | 0      | R/W |
| Index storing           | 913  | U16 | 0             | +2 <sup>32</sup> -1 | -      | R   |
| Out vlt level           | 921  | U16 | 0             | 16384               | 16384  | R/W |
| F act speed (rpm) [spd] | 924  | I16 | -32768        | 32767               | -      | R   |
| F act speed (d) [spd]   | 925  | I16 | -32768        | 32767               | -      | R   |
| F T curr % [curr]       | 928  | I16 | -2 * TOP_CURR | +2 * TOP_CURR       | -      | R   |
| Speed ratio             | 1017 | I16 | 0             | 32767               | +10000 | R/W |
| Spd draw out (d) [SPD]  | 1018 | I16 | -32768        | 32767               | -      | R   |

**NOTE !**

- 1) [SPD] = Speed settings are expressed in *RPM* \* 4
- 2) [CURR] = Current settings are expressed in European Drive rated current / 2000 = Motor Amps (2000 is **TOP\_CURR**)
- 3) [ENC\_PLS] = Encoders positions are expressed in *pulses* \* 4
- 4) [ENC\_TIM] = Encoders **last time** (s) are expressed in *50ns units* (1=50nS)
- 5) Encoder 2 parameters (marked with "\*" in the table) can be read by the APC200 only if the parameter **Speed fbk sel** = encoder 2
- 6) Encoder 1 parameters (marked with "\*" in the table) can be read by the APC200 only if
  - the parameter **Speed fbk sel** = encoder 2 and
  - a digital encoder is used as encoder 1 (interfacing with the converter by means of the DEII card)
- 7) **Speed reg output [%]** contains valid information even if the speed regulator is disabled (Enable speed reg = Disabled). If Speed reg output is enabled, it contains the sum of actual speed regulator output and T current ref 2.



# 11 - REPLACEMENT PARTS

## 11.1 HARDWARE CONFIGURATION (CARDS / DIP SWITCHES / JUMPERS)

The functionality and use of the TPD32 converter are the same for the whole device range. Different power and control cards are mounted depending on the output rated current. The following table indicates the card range for each converter type.

| Function                   | Type             | Drawing  | Converter size [A] |          |                       |                        |                         |
|----------------------------|------------------|----------|--------------------|----------|-----------------------|------------------------|-------------------------|
|                            |                  |          | 17...35<br>20...40 | 56<br>70 | 88...148<br>110...185 | 224...450<br>280...650 | 560...850<br>770...1050 |
| <b>Regulation</b>          | R-TPD32          | ESE 4155 | X                  | X        | X                     | X                      | X                       |
| <b>Power /<br/>Control</b> | FIR1-.. (-2B/4B) | ESE 2135 | X                  | X        | X                     | -                      | -                       |
|                            | FIR2-.. (-2B/4B) | ESE 2238 | -                  | -        | -                     | X                      | -                       |
|                            | FIR3-32 (-2B/4B) | ESE 2260 | -                  | -        | -                     | -                      | X                       |
|                            | PBB (-2B/-4B)    | ESE 2275 | X                  | X        | -                     | -                      | -                       |
| <b>Supply</b>              | SW1-31           | ESE 2192 | X                  | X        | X                     | -                      | -                       |
|                            | SW2-32           | ESE 2239 | -                  | -        | -                     | X                      | -                       |
|                            | SW3-32           | ESE 2239 | -                  | -        | -                     | -                      | X                       |
| <b>Field</b>               | PFC1A-32         | ESE 2213 | X                  | X        | X                     | -                      | -                       |
|                            | PFC2-31          | ESE 2271 | -                  | -        | -                     | X                      | -                       |
|                            | SN-FC            | ESE 2265 | -                  | -        | -                     | -                      | X                       |
| <b>Filter</b>              | FL-31            | ESE 2253 | -                  | -        | -                     | -                      | X                       |
| <b>Snubber</b>             | SN5-31           | ESE 2246 | -                  | -        | -                     | X                      | X                       |
| <b>I/O expansion</b>       | TBO (opt.)       | ESE 2121 | X                  | X        | X                     | X                      | X                       |

**Important note:** When the FIR card is replaced, **switches S3 and S4 must be set according to the size of the converter**, see paragraphs 11.3, 1.4 and 11.5.

# 11.2 R-TPD32 REGULATION CARD

For more information see chapter 4.4.

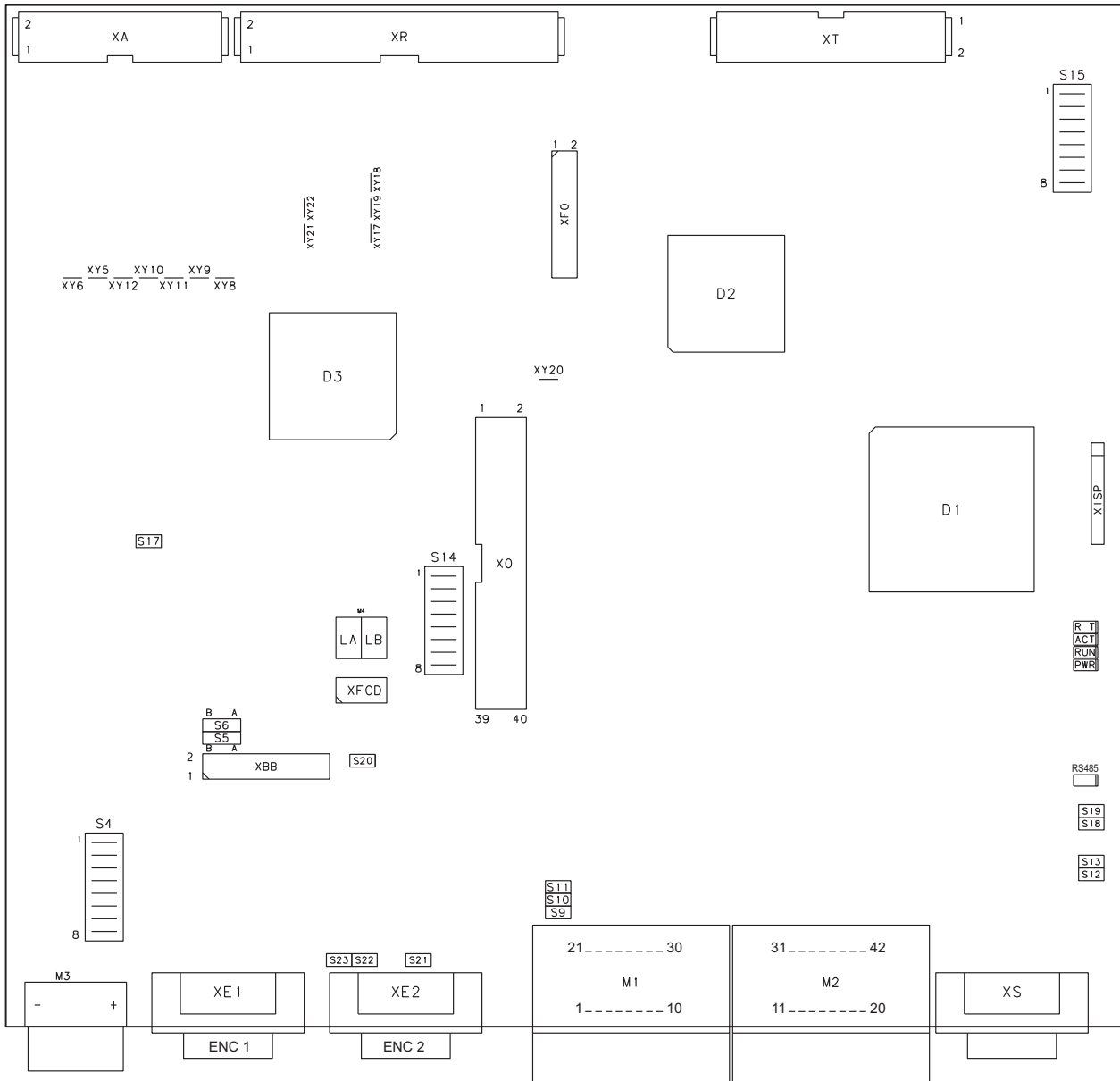

# 11.3 FIR1-... POWER/DRIVER CARDS

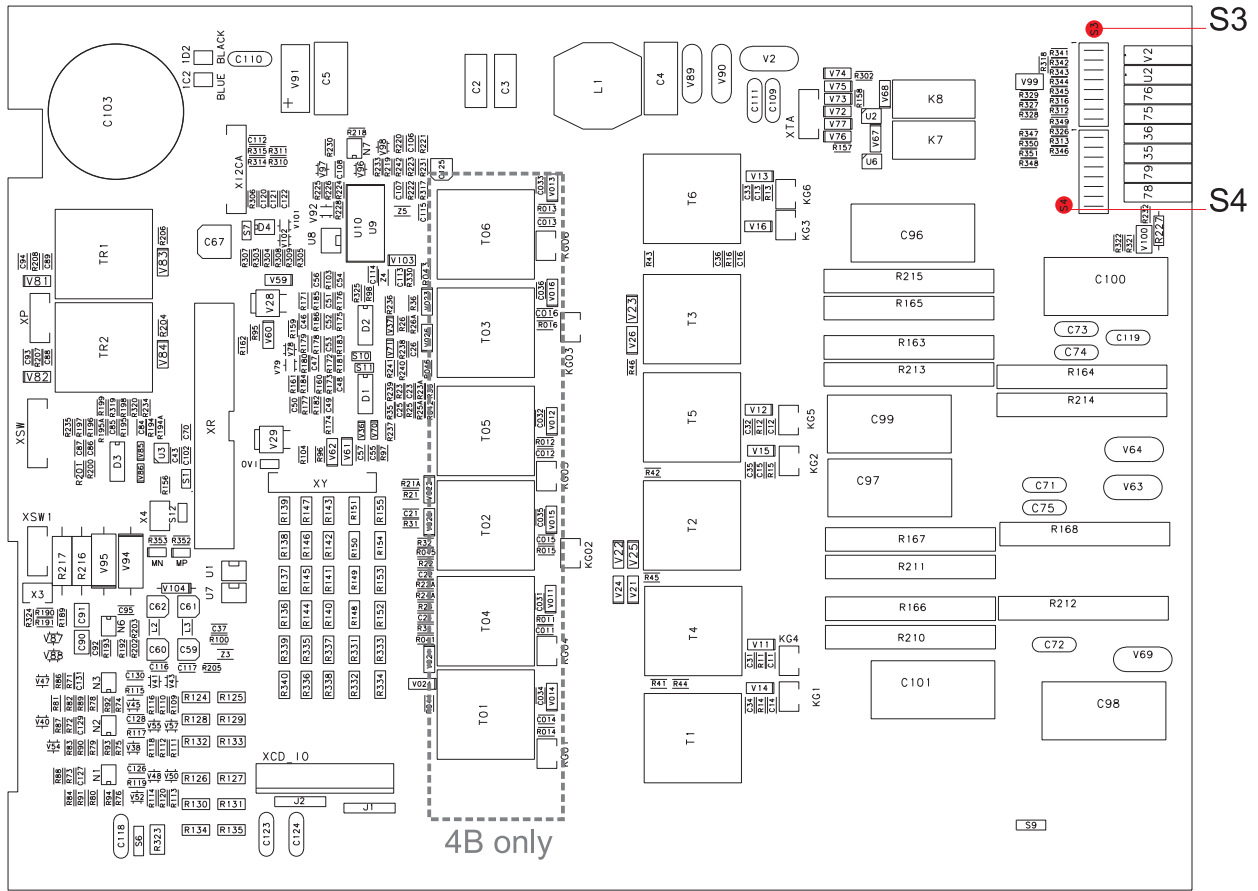

Table 11.3.1: Selection of dip-switches "S3-XX" and "S4-XX" for FIR1-... cards (Rev. index > "q")

| Line voltage [V <sub>AC</sub> ]                               | IdN TPD32 [A] | Dip-switch |      |      |      |      |      |      |      | Dip-switch |      |      |      |      |      |      |      |  |
|---|---------------|------------|------|------|------|------|------|------|------|------------|------|------|------|------|------|------|------|--|
|   |               | S3-1       | S3-2 | S3-3 | S3-4 | S3-5 | S3-6 | S3-7 | S3-8 | S4-1       | S4-2 | S4-3 | S4-4 | S4-5 | S4-6 | S4-7 | S4-8 |  |
| EU sizes<br>230V <sub>AC</sub><br>to<br>500V <sub>AC</sub>    | 20            | ON         | ON   |      | ON   |      |      |      |      |            |      |      |      |      |      |      |      |  |
|   | 40            |            |      |      | ON   | ON   | ON   | ON   |      |            |      |      |      |      |      |      |      |  |
|   | 70            | ON         |      |      | ON   |      |      | ON   |      |            |      | ON   |      |      |      |      |      |  |
|   | 110           |            |      |      | ON   |      |      | ON   |      |            |      |      | ON   | ON   |      |      |      |  |
|   | 140           |            |      |      | ON   |      |      |      |      |            | ON   |      | ON   |      |      | ON   |      |  |
| 185   |               |            |      | ON   |      |      |      |      |      |            | ON   |      |      |      | ON   |      |      |  |
| USA sizes<br>230V <sub>AC</sub> -<br>to<br>480V <sub>AC</sub> | 17            | ON         | ON   |      | ON   |      |      |      |      |            |      |      |      |      |      |      |      |  |
|   | 35            |            |      |      | ON   | ON   | ON   | ON   |      |            |      |      |      |      |      |      |      |  |
|   | 56            | ON         |      |      | ON   |      |      | ON   |      |            |      | ON   |      |      |      |      |      |  |
|   | 88            |            |      |      | ON   |      |      | ON   |      |            |      |      | ON   | ON   |      |      |      |  |
|   | 112           |            |      |      | ON   |      |      |      |      |            | ON   |      |      |      |      | ON   |      |  |
| 148   |               |            |      | ON   |      |      |      |      |      |            | ON   | ON   |      |      | ON   |      |      |  |

# 11.4 FIR2-... POWER/DRIVER CARD

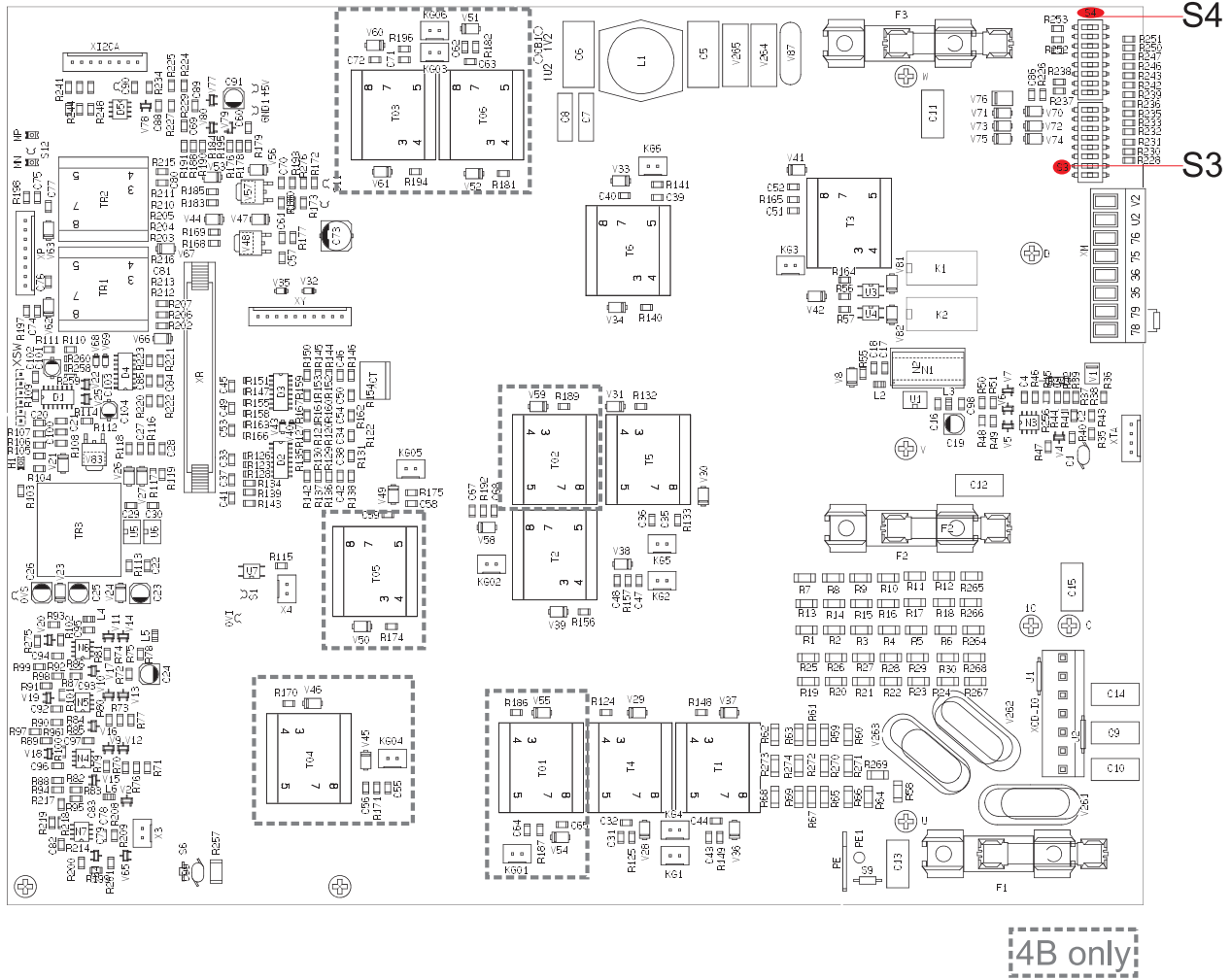

Table 11.4.1: Selection of dip-switches "S3-XX" and "S4-XX" for FIR2-X-... cards (Rev. index ≥ "n")

| Line voltage [V <sub>AC</sub> ]                             | IdN TPD32 [A] | Dip-switch |      |      |      |      |      |      |      | Dip-switch |      |      |      |      |      |      |      |
|---|---------------|------------|------|------|------|------|------|------|------|------------|------|------|------|------|------|------|------|
|   |               | S3-1       | S3-2 | S3-3 | S3-4 | S3-5 | S3-6 | S3-7 | S3-8 | S4-1       | S4-2 | S4-3 | S4-4 | S4-5 | S4-6 | S4-7 | S4-8 |
| EU sizes<br>230V <sub>AC</sub><br>to<br>500V <sub>AC</sub>  | 280           |            |      |      |      |      |      |      | ON   |            |      |      | ON   |      | ON   |      |      |
|   | 350           |            |      |      |      |      |      |      |      |            |      | ON   |      |      |      | ON   |      |
|   | 420           |            |      |      |      |      |      |      |      | ON         |      | ON   |      |      |      | ON   |      |
|   | 480           | ON         |      |      |      |      |      |      |      | ON         |      |      |      |      | ON   | ON   |      |
|   | 500           |            |      |      |      |      |      |      |      | ON         | ON   | ON   |      |      | ON   | ON   | ON   |
| USA sizes<br>230V <sub>AC</sub><br>to<br>480V <sub>AC</sub> | 224           |            |      |      |      |      |      | ON   |      |            |      |      | ON   |      | ON   |      |      |
|   | 280           |            |      |      |      |      |      |      |      |            |      | ON   |      |      |      | ON   |      |
|   | 336           |            |      |      |      |      |      |      | ON   |            | ON   | ON   |      |      |      | ON   |      |
|   | 400           |            |      |      |      |      |      |      | ON   | ON         | ON   |      |      |      | ON   | ON   |      |
|   | 450           |            |      |      |      |      |      |      | ON   | ON         | ON   |      |      |      | ON   | ON   | ON   |

# 11.5 FIR3-32 POWER/DRIVER CARD

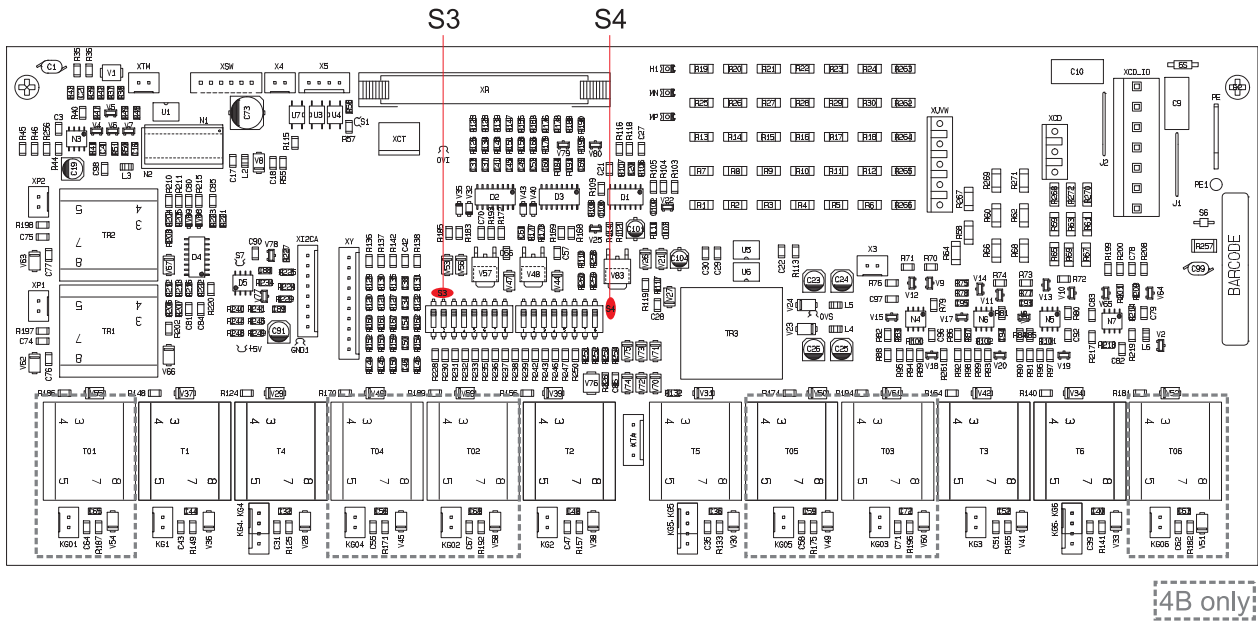
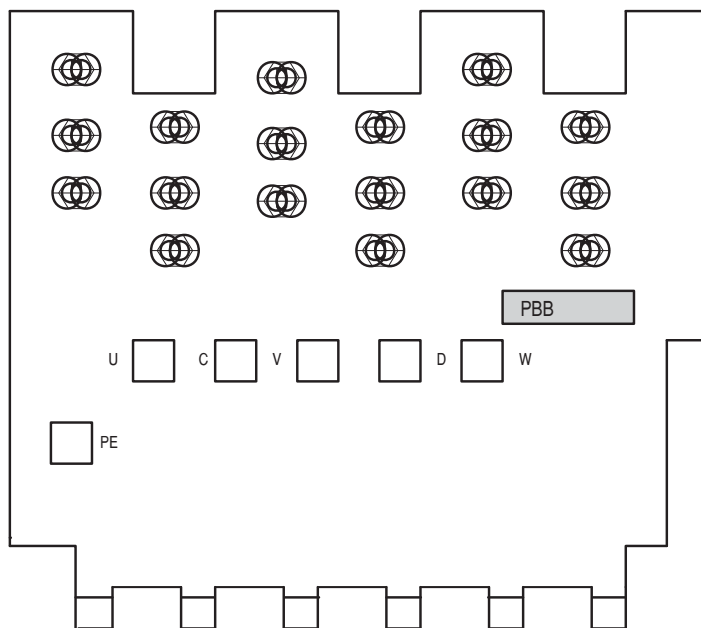

Table 11.5.1: Selection of dip-switches "S3-XX" and "S4-XX" for FIR3-32- cards. (Rev. index ≥ "m")

| Line voltage [V <sub>ac</sub> ]                             | IdN TPD32 [A] | Dip-switch |      |      |      |      |      |      |      | Dip-switch |      |      |      |      |      |      |      |
|---|---------------|------------|------|------|------|------|------|------|------|------------|------|------|------|------|------|------|------|
|   |               | S3-1       | S3-2 | S3-3 | S3-4 | S3-5 | S3-6 | S3-7 | S3-8 | S4-1       | S4-2 | S4-3 | S4-4 | S4-5 | S4-6 | S4-7 | S4-8 |
| EU sizes<br>230V <sub>ac</sub><br>to<br>500V <sub>ac</sub>  | 700           | ON         |      |      |      | ON   |      |      |      |            | ON   |      |      |      |      |      | ON   |
|   | 770           | ON         |      |      |      |      |      |      |      | ON         | ON   |      | ON   |      |      |      | ON   |
|   | 900           |            |      |      |      |      |      |      | ON   |            | ON   |      |      |      | ON   |      | ON   |
|   | 1000          |            | ON   |      |      |      |      |      |      |            |      | ON   | ON   | ON   |      |      | ON   |
| USA sizes<br>230V <sub>ac</sub><br>to<br>480V <sub>ac</sub> | 1050          | ON         |      |      |      |      |      | ON   |      |            |      |      |      |      |      | ON   | ON   |
|   | 560           | ON         |      |      |      |      |      |      |      |            | ON   | ON   |      |      |      |      | ON   |
|   | 800           | ON         |      |      |      |      |      |      |      |            |      |      |      |      |      | ON   | ON   |
|   | 850           | ON         |      |      |      |      |      | ON   |      |            |      |      |      |      |      | ON   | ON   |

## 11.6 PBB POWER CONNECTION CARD



## 11.7 PFC1-32 FIELD CONVERTER

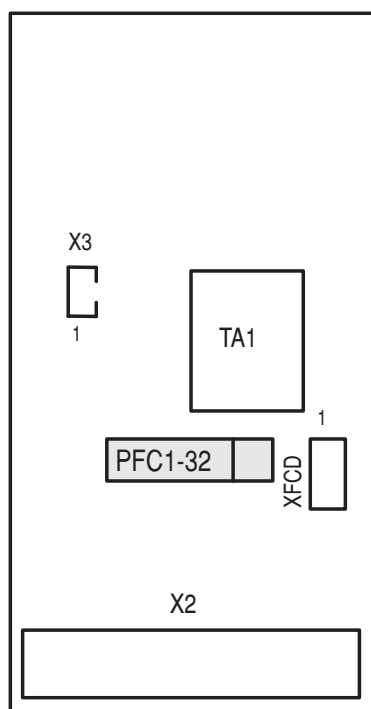

## 11.8 PFC2-31 FIELD CONVERTER

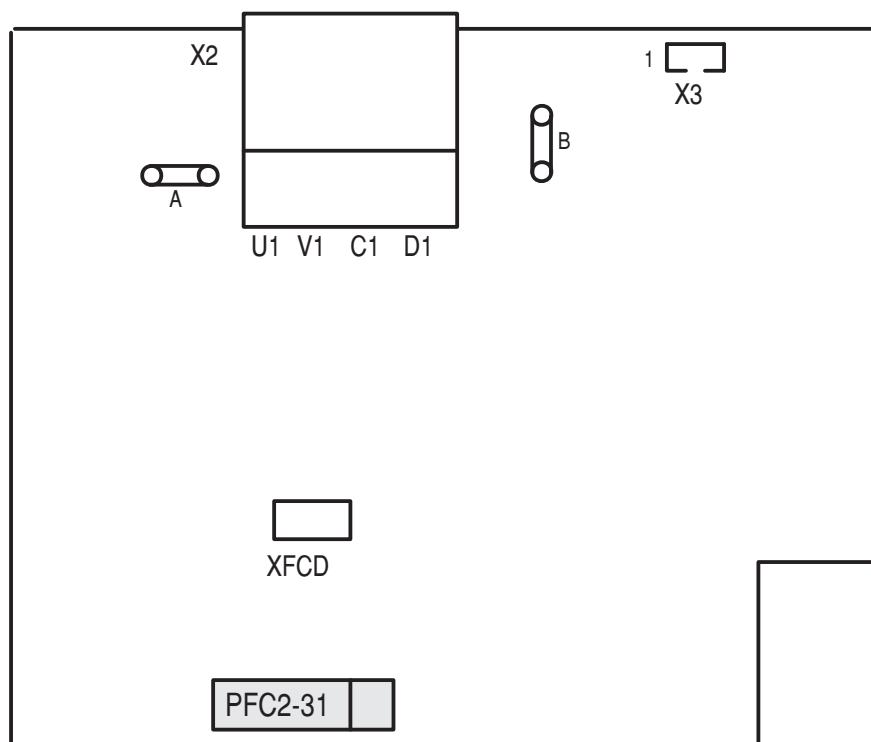

## 11.9 SN-FC FIELD SNUBBER

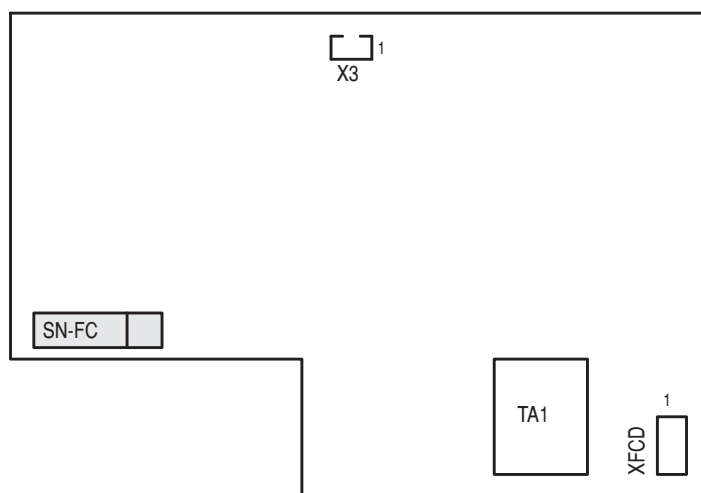

## 11.10 SN5-31 SNUBBER

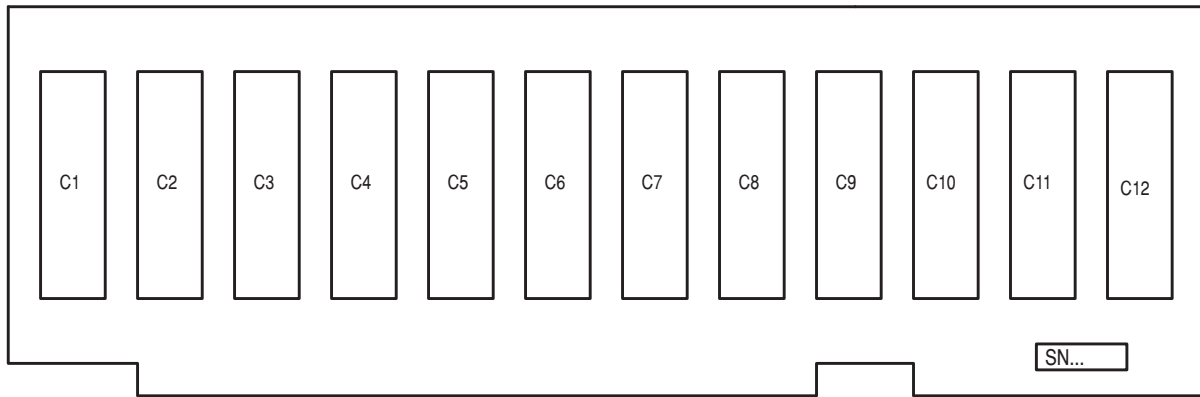

## 11.11 SW1-31 POWER SUPPLY CARD

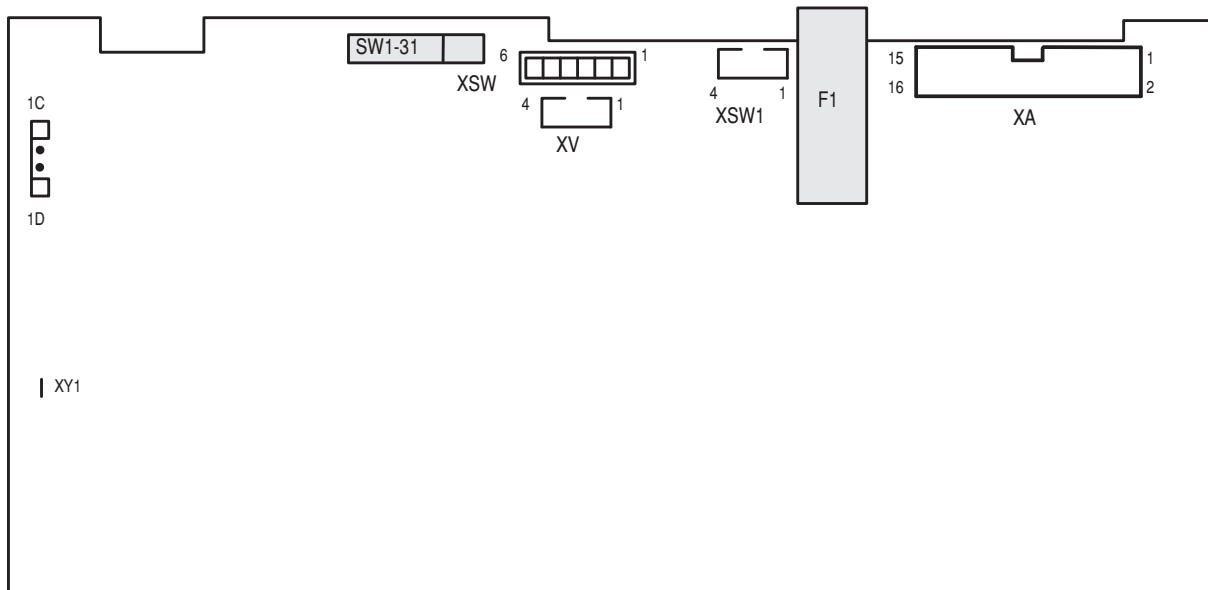



## 11.12 SW2-32 POWER SUPPLY CARD

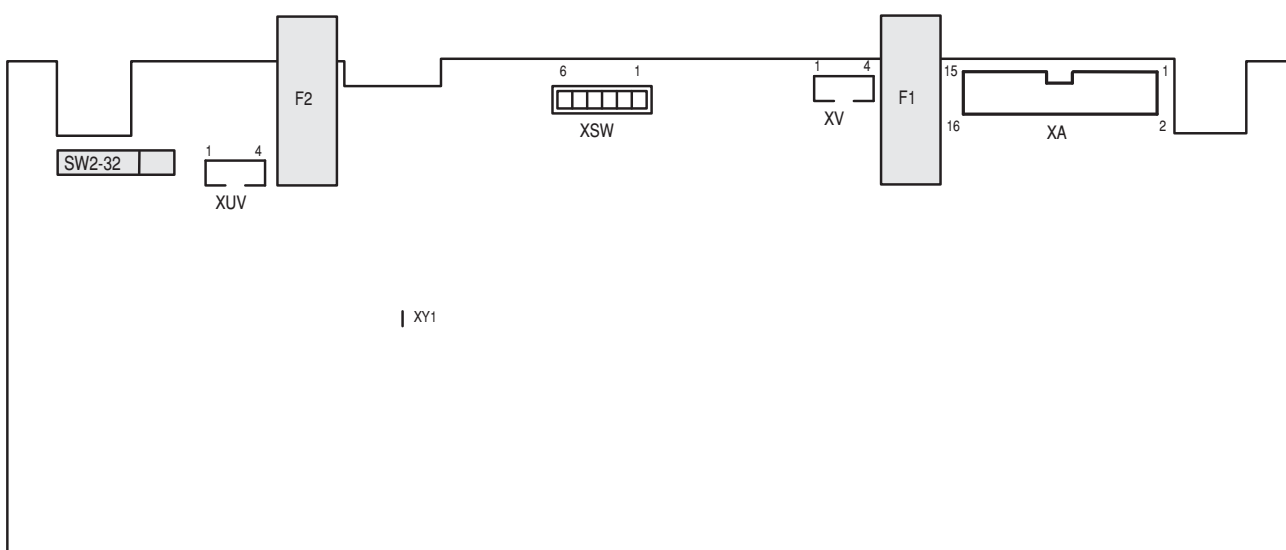

## 11.13 FL-31 FILTER CARD

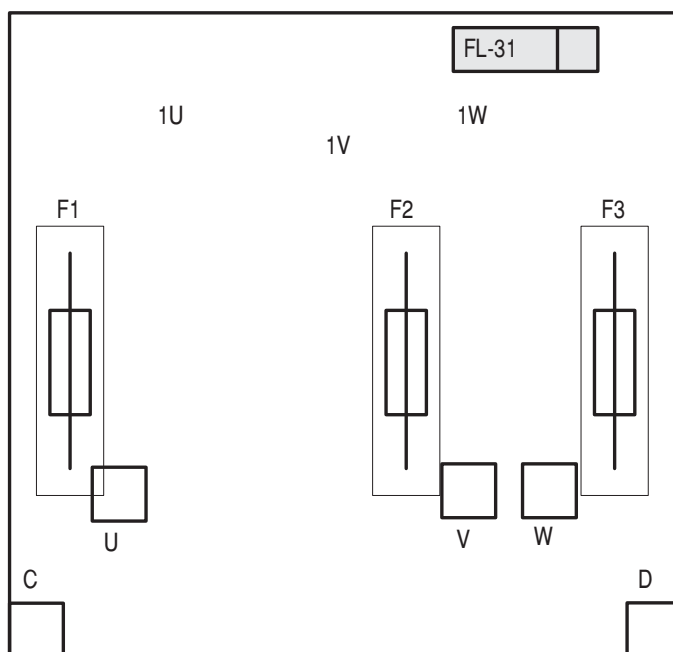

### 11.14 CN3 CONNECTION CARD

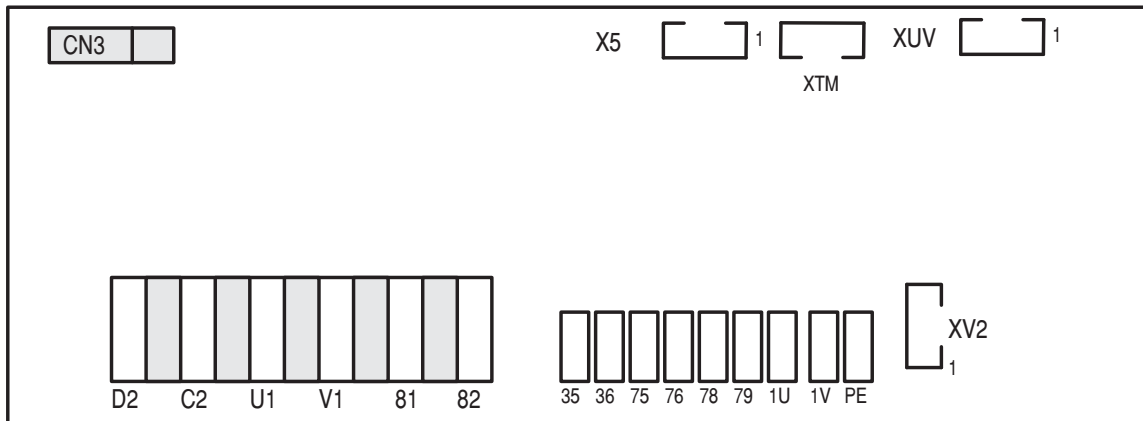

### 11.15 I/O OPTION CARD TBO

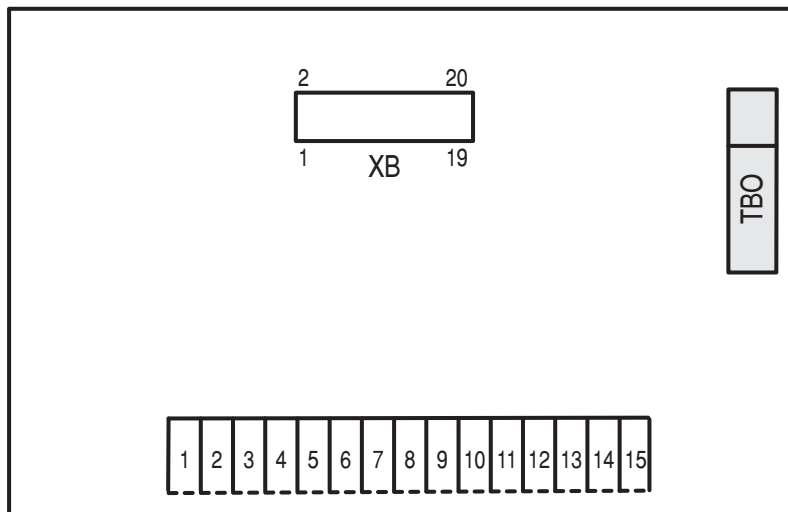

**GEFRAN BENELUX**

Lammerdries-Zuid, 14A  
B-2250 OLEN  
Ph. +32 (0) 14248181  
Fax. +32 (0) 14248180  
info@gefran.be

**GEFRAN BRASIL  
ELETRONICA**

Avenida Dr. Altino Arantes,  
377/379 Vila Clementino  
04042-032 SÃO PAULO - SP  
Ph. +55 (0) 1155851133  
Fax +55 (0) 1132974012  
gefran@gefran.com.br

**GEFRAN DEUTSCHLAND**

Philipp-Reis-Straße 9a  
63500 SELIGENSTADT  
Ph. +49 (0) 61828090  
Fax +49 (0) 6182809222  
vertrieb@gefran.de

**SIEI AREG - GERMANY**

Gottlieb-Daimler-Strasse 17/3  
D-74385 Pleidelsheim  
Ph. +49 7144 89 736 0  
Fax +49 7144 89 736 97  
info@sieiareg.de

**GEFRAN ESPAÑA**

C/ de Vic, 109-111  
08160 Montmeló (BARCELONA)  
Ph. +34 934982643  
Fax +34 935721571  
comercial.espana@gefran.es

**GEFRAN FRANCE**

4, rue Jean Desparmet - BP 8237  
69355 LYON Cedex 08  
Ph. +33 (0) 478770300  
Fax +33 (0) 478770320  
commercial@gefran.fr

**GEFRAN SUISSE SA**

Rue Fritz Courvoisier 40  
2302 La Chaux-de-Fonds  
Ph. +41 (0) 329684955  
Fax +41 (0) 329683574  
office@gefran.ch

**GEFRAN - UK Ltd.**

7 Pearson Road, Central Park  
TELFORD, TF2 9TX  
Ph. +44 (0) 845 2604555  
Fax +44 (0) 845 2604556  
sales@gefran.co.uk

**GEFRAN Inc.**

8 Lowell Avenue  
WINCHESTER - MA 01890  
Toll Free 1-888-888-4474  
Ph. +1 (781) 7295249  
Fax +1 (781) 7291468  
info@gefraninc.com

**GEFRAN SIEI - ASIA**

Blk. 30 Loyang way  
03-19 Loyang Industrial Estate  
508769 SINGAPORE  
Ph. +65 6 8418300  
Fax. +65 6 7428300  
info@gefransiei.com.sg

**GEFRAN SIEI Drives Technology  
(Shanghai) Co., Ltd.**

No. 1285, Beihe Road, Jiading District,  
Shanghai, China 201807  
Ph. +86 21 69169898  
Fax +86 21 69169333  
info@gefransiei.com.cn

**GEFRAN SIEI Electric (Shanghai) Pte. Ltd.**

No. 1285, Beihe Road, Jiading District,  
Shanghai, China 201807  
Ph. +86 21 69169898  
Fax +86 21 69169333  
info@gefransiei.com.cn

**GEFRAN INDIA Pvt. Ltd.**

**Head office (Pune office)**  
Survey No: 182/1 KH, Bhukum,  
Paud road, Taluka - Mulshi,  
Pune - 411 042. MH, INDIA  
Ph: +91-20-3939 4400  
Fax: +91-20-3939 4401  
gefran.india@gefran.in

**Branch office (Mumbai office)**

Laxmi Palace, M.G. Road  
Naupada, Thane (W)  
400602 Mumbai  
Ph. +91 22 2540 3384  
Ph. +91 22 2542 6640  
Fax +91 22 2542 7889  
support.india@gefran.in

**GEFRAN****GEFRAN S.p.A.**

Via Sebina 74  
25050 Provaglio d'Iseo (BS) ITALY  
Ph. +39 030 98881  
Fax +39 030 9839063  
info@gefran.com  
www.gefran.com

**Drive & Motion Control Unit**

Via Carducci 24  
21040 Gerenzano (VA) ITALY  
Ph. +39 02 967601  
Fax +39 02 9682653  
infomotion@gefran.com

**Technical Assistance :**  
technohelp@gefran.com

**Customer Service :**  
motioncustomer@gefran.com  
Ph. +39 02 96760500  
Fax +39 02 96760278

Manuale TPD32 9.3 -EN

Rev. 0.2 - 21-11-11



1S4A43E