

DS6500

INSTALLATION QUICK REFERENCE



CONTENTS

DS6500-100-010 MASTER/SLAVE MODELS 1

DS6500-100-011 PROFIBUS MODELS 7

DS6500-100-012 ETHERNET MODELS 12

DS6500-100-015 DEVICENET MODELS 17

DS6500-105-0XX OSCILLATING MIRROR MODELS 22

COMMON FEATURES 24

	<i>For further details on product installation, see the complete Reference Manual available on the configuration CD-ROM included with this product.</i>
NOTE	

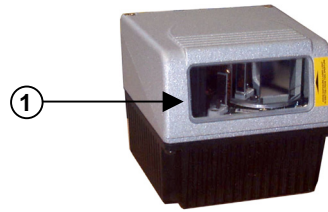

Figure A

① Laser Beam Output Window

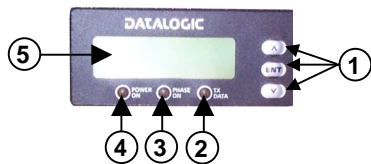

Figure B

- ① Programming Keypad
- ② TX Data LED (Green)
- ③ Phase On LED (Yellow)
- ④ Power On LED (Red)
- ⑤ LCD Display



Figure C

- ① Main/Aux. Interface 25-pin D-sub Male Connector
- ② Lonworks 9-pin Male Connector
- ③ Lonworks 9-pin Female Connector

Available Models:

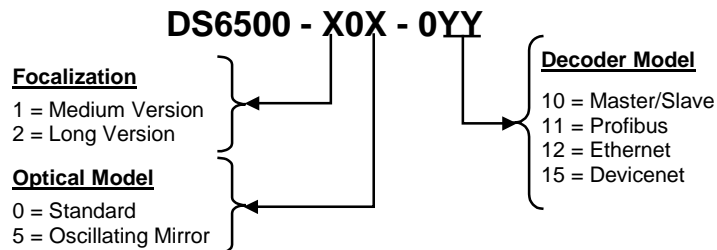

Technical Features:

ELECTRICAL FEATURES		OPTICAL FEATURES		
Supply Voltage	15 - 30 Vdc	Light Receiver	Avalanche photodiode	
Power Consumption	15 W typical 20 W Max. (including startup current)	Wavelength	630 to 680 nm	
Communication Interfaces	Main (isolated)	Safety Class	Class 2-EN 60825-1; Class II-CDRH	
	RS232	Laser Control	Security system to turn laser off in case of motor slow down	
	RS485 full-duplex			1200 to 115200
	RS485 half-duplex			
	20 mA C.L. (INT-30 with C-BOX 100 only)	19200	READING FEATURES	
	Auxiliary		Scan Rate	600-1200 scans/s
RS232	1200 to 115200	Max. Resolution Max. Read. Distance Max. Read. Width Max. Depth of Field	(see reading diagram)	
Other				
Lonworks	1,25 Mb/s			
Inputs		USER INTERFACE		
Ext. Trigger 1, 3 aux. digital inputs	(optocoupled NPN or PNP)	LCD Display	2 lines by 16 characters LCD	
Outputs		Keypad	3 keys	
3 software programmable digital outputs	(optocoupled)	LED Indicators	Power ON (red color) Phase ON (yellow color) TX Data (green color)	

SOFTWARE FEATURES		ENVIRONMENTAL FEATURES		
Readable Codes	Interleaved 2/5 Code 39 standard Codabar Code 128 EAN 128 Code 93 (standard & full ASCII) EAN/UPC	Operating Temperature	0° to +40 °C (+32 to +104 °F)	
		Storage Temperature	-20° to +70 °C (-4° to +158 °F)	
		Humidity	90% non condensing	
		Vibration Resistance	IEC 68-2-6 test FC 1.5 mm; 10 to 55 Hz 2 hours on each axis	
Code Selection	Up to 10 codes during one reading phase	Shock Resistance	IEC 68-2-27 test EA 30 G; 11 ms 3 shocks on each axis	
Headers and Terminators	Up to 128-byte headers and 128-byte terminators			
Operating Modes	On Line, Automatic, Test, PackTrack™			
Config. Mode	Genius™ utility program	Protection Class	IP64	
Parameter Storage	Non-volatile internal FLASH	PHYSICAL FEATURES		
			Std Models	Oscill. Mirror
		Dimensions mm (inch)	110x113x99 (4.33x4.45x3.9)	113x180x104.5 (4.45x7.08x4.11)
		Weight	1.5 kg (3.3 lb)	2.0 kg (4.4 lb)

Accessories:

Name	Description	Part Number
CAB-6001	Cable to C-BOX100 1 m	93A051190
CAB-6002	Cable to C-BOX100 2 m	93A051200
CAB-6005	Cable to C-BOX100 5 m	93A051210
CAB-6010	Cable to C-BOX100 10 m	93A051271
CAB-6101	Cable master/slave 1 m	93A051220
CAB-6102	Cable master/slave 2 m	93A051230
CAB-6105	Cable master/slave 5 m	93A051240
CAB-6112	Cable master/slave no power 2 m	93A051224
CAB-6115	Cable master/slave no power 5 m	93A051225
CAB-6305	Power cable Fam 6k 5 m	93ACC1768
CAB-6310	Power cable Fam 6k 10 m	93ACC1752
C-BOX 100	Passive connection box	93ACC1510
INT-30	20 mA C.L. interface board for C-BOX 100	93A151022
GFC-60	90° mirror	93A201100
GFC-600	90° mirror close distance	93A201102
PWR-120	Power unit 110/230 V AC - 24 V DC	93ACC1530
BTK-6000	Terminator kit (5 pcs)	93ACC1710
PG6002	Single unit power supply – US	93ACC1718
PG6001	Single unit power supply – UK	93ACC1719
PG6000	Single unit power supply – EU	93ACC1720
FBK-6000	Fast bracket kit (2 pcs)	93ACC1721
US-60	Mounting bracket kit (5 pcs) for multisided stations	890001020
MEP-542	Photocell kit – PNP	93ACC1727
MEP-543	Photocell kit – NPN	93ACC1728

Electrical Connections:

The DS6500 reader provides a 25-pin male D-sub connector for connection to power supply, Host interface (Main and Aux), and input/output signals.

Two 9-pin connectors provide access to the scanner's local Lonworks network used for both input and output connections to build a multi-sided or omni-station system.

The details of the connector pins are indicated in the following table:

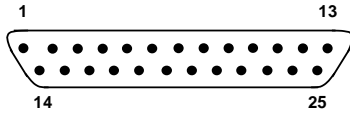
25-pin D-Sub Connector Pinout						
Pin	Name	Function				
1	Shield	Internally connected by capacitor to chassis	 <p>25-pin male D-sub Connector</p>			
20	RXAUX	Receive data of auxiliary RS232 (referred to GND)				
21	TXAUX	Transmit data of auxiliary RS232 (referred to GND)				
8	OUT 1+	Configurable digital output 1 – positive pin				
22	OUT 1-	Configurable digital output 1 – negative pin				
11	OUT 2+	Configurable digital output 2 – positive pin				
12	OUT 2-	Configurable digital output 2 – negative pin				
16	OUT 3A	Configurable digital output 3 – polarity insensitive				
17	OUT 3B	Configurable digital output 3 – polarity insensitive				
18	EXT_TRIG A	External trigger (polarity insensitive)				
19	EXT_TRIG B	External trigger (polarity insensitive)				
6	IN2A	Input signal 2 (polarity insensitive)				
10	IN2B	Input signal 2 (polarity insensitive)				
14	IN3A	Input signal 3 (polarity insensitive)				
15	IN4A	Input signal 4 (polarity insensitive)				
24	IN_REF	Common reference of IN3 and IN4 (polarity insensitive)				
9, 13	VS	Supply voltage – positive pin				
23, 25	GND	Supply voltage – negative pin				
Pin	RS232	RS485 Full-Duplex			RS485 Half-Duplex	20 mA C.L. (INT-30 with C-BOX 100 only)
2	TX	TX485+			RTX485+	see INT-30 instructions
3	RX	RX485+				
4	RTS	TX485-	RTX485-			
5	CTS	RX485-				
7	GND_ISO	GND_ISO	GND_ISO			

* For 20 mA C.L. connections, GND is the same of the scanner power supply.

9-pin Lonworks Connector Pinout		
Pin	Name	Function
1	Shield	Cable shield
9	VS	Supply voltage – positive pin
2	GND	Supply voltage – negative pin
6	VS_I/O	Supply voltage of I/O circuit
3	Ref_I/O	Reference voltage of I/O circuit
4	SYS_ENC_I/O	System signal
5	SYS_I/O	System signal
7	LON A	Lonworks line (polarity insensitive)
8	LON B	Lonworks line (polarity insensitive)

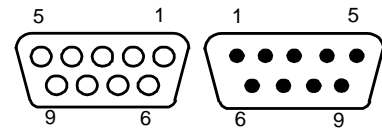

Female Male

9-pin Local Lonworks Connectors

Network Termination:

When building a local Lonworks system the network must be properly terminated by positioning a BTK-6000 terminator on the DS6500 master reader (BTK-6000 female side) and on the last slave reader (BTK-6000 male side).

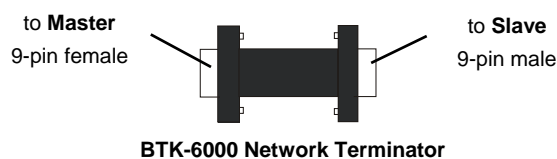

Connectivity:

Point-to-Point Layout

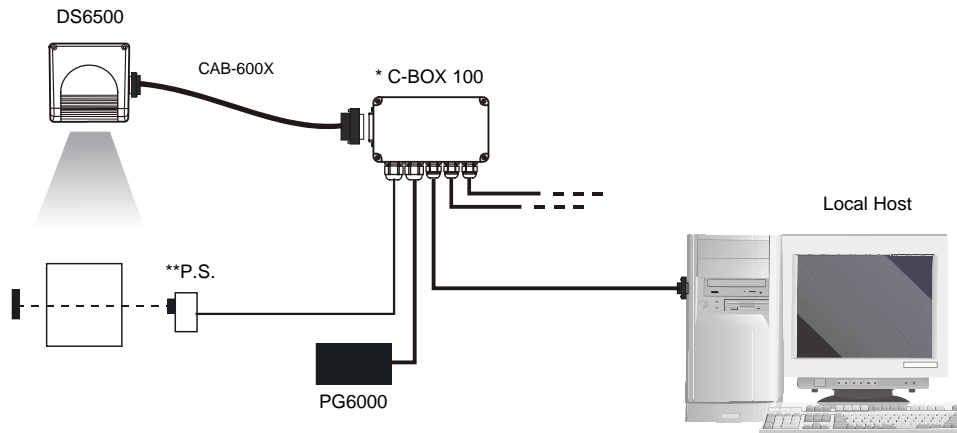

* C-BOX 100 can support up to 2 DS6500 readers. Please contact Datalogic USS Technical Support, if your application requires a multi-slave network.

** P.S. (Presence Sensor) connected to External Trigger input.

Pass Through Layout

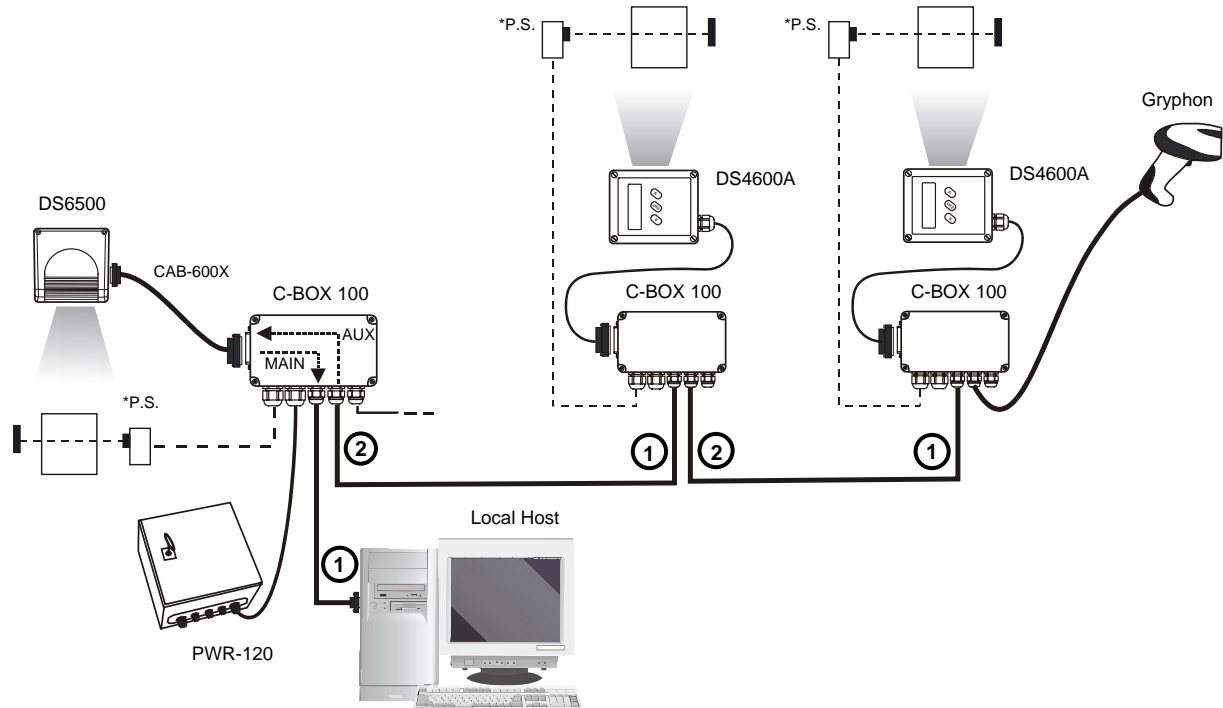

① Main Serial Interface ② Auxiliary Serial Interface

* P.S. (Presence Sensor) connected to External Trigger input.

Multiplexer Layout

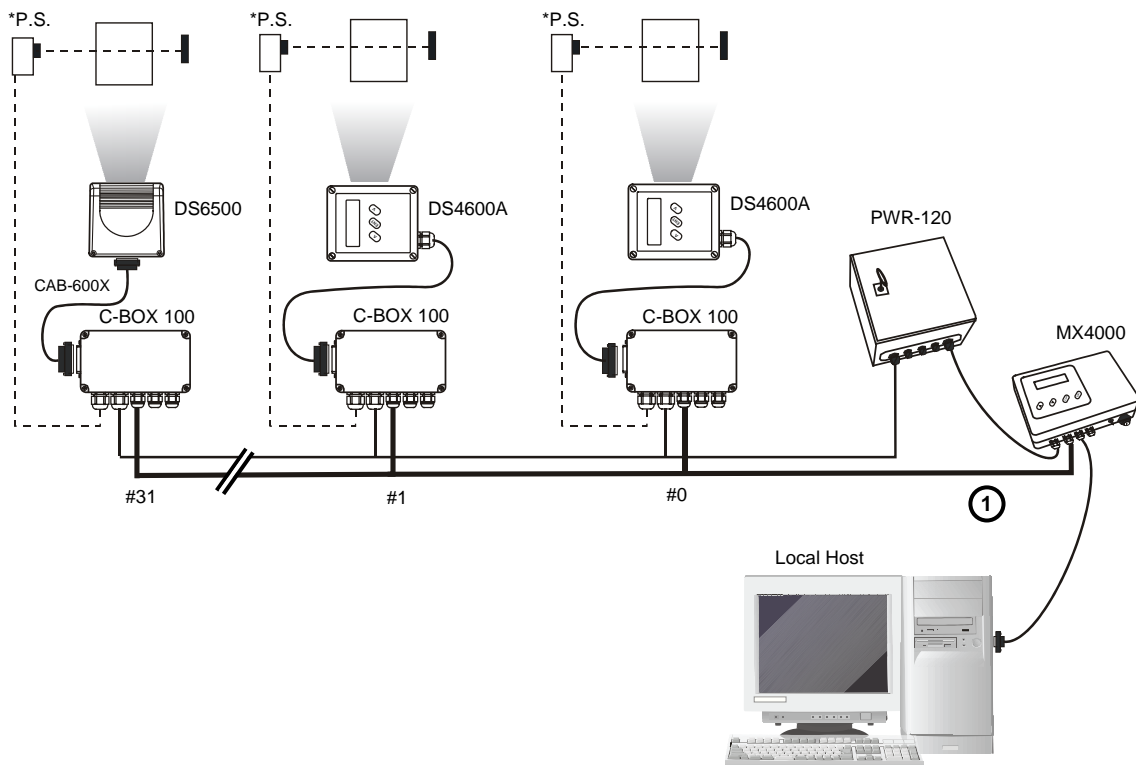

① RS485 HD Main Interface

Local Lonworks Network (Single P.S.)

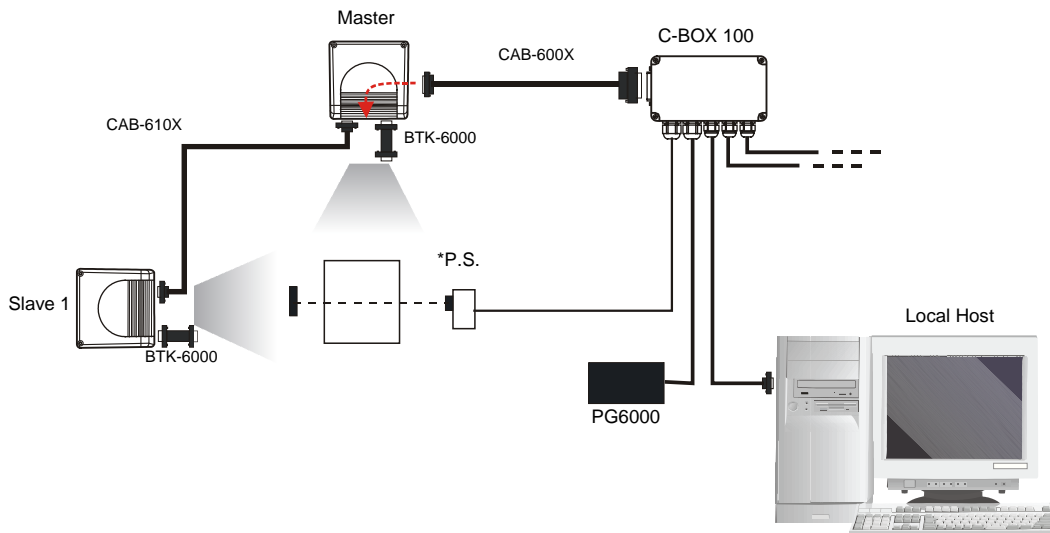

Single P.S. with 2 Readers

* P.S. (Presence Sensor) connected to External Trigger input.

Local Lonworks Network (Single P.S.)

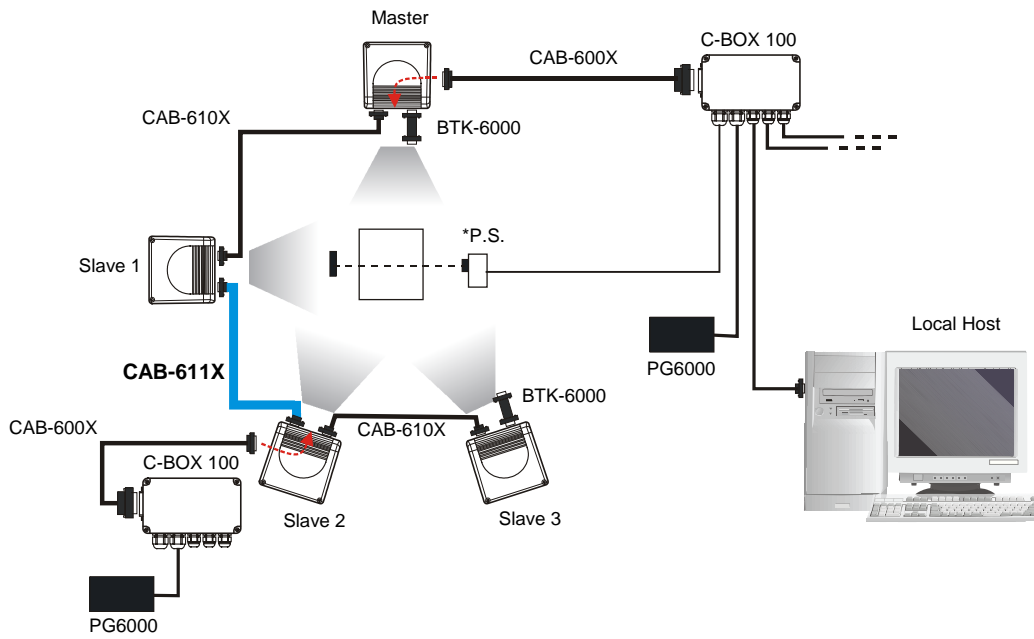

Single P.S. with more than 2 Readers and Multiple Power Units

Local Lonworks Network (Single P.S.)

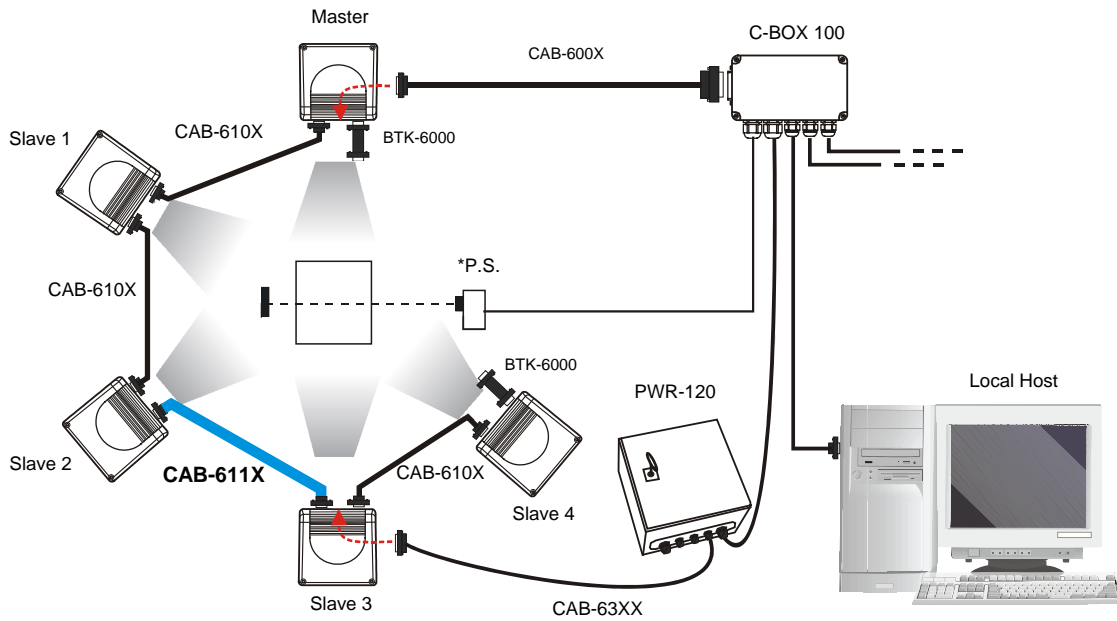

Single P.S. with more than 2 Readers and Single Power Unit

* P.S. (Presence Sensor) connected to External Trigger input.

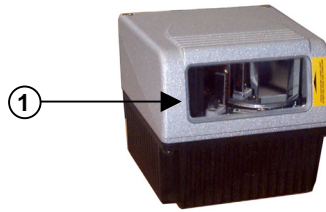

Figure A

① Laser Beam Output Window

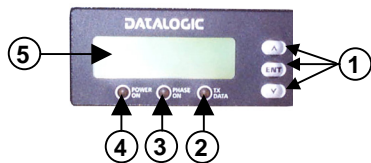

Figure B

- ① Programming Keypad
- ② TX Data LED (Green)
- ③ Phase On LED (Yellow)
- ④ Power On LED (Red)
- ⑤ LCD Display

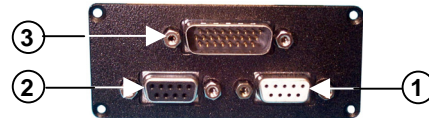
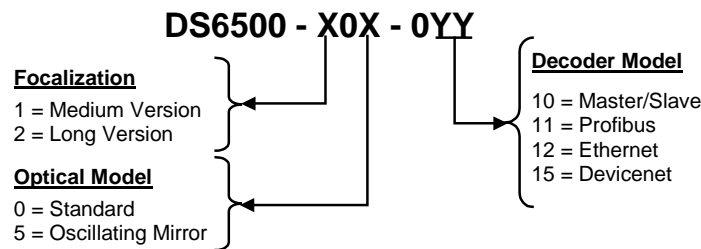

Figure C

- ① Profibus 9-pin Female Connector (white)
- ② Lonworks 9-pin Female Connector
- ③ Main/Aux. Interface 26-pin D-Sub Male Connector

Available Models:



Technical Features:

ELECTRICAL FEATURES		OPTICAL FEATURES		
Supply Voltage	15 - 30 Vdc	Light Receiver	Avalanche photodiode	
Power Consumption	15 W typical 20 W Max. (including startup current)	Wavelength	630 to 680 nm	
Communication Interfaces	Main (isolated)	Baud Rate	Safety Class	
	RS232			1200 to 115200
	RS485 full-duplex			
	RS485 half-duplex	19200	Laser Control	Security system to turn laser off in case of motor slow down
	20 mA C.L. (INT-30 with C-BOX 100 only)			
	Auxiliary		READING FEATURES	
	RS232	1200 to 115200	Scan Rate	600-1200 scans/s
Other		Max. Resolution Max. Read. Distance Max. Read. Width Max. Depth of Field	(see reading diagram)	
Lonworks	1,25 Mb/s			
Profibus	12 Mb/s			
Inputs		USER INTERFACE		
Ext. Trigger 1, 3 aux. digital inputs	(optocoupled NPN or PNP)	LCD Display	2 lines by 16 characters LCD	
Outputs		Keypad	3 keys	
3 software programmable digital outputs	(optocoupled)	LED Indicators	Power ON (red color) Phase ON (yellow color) TX Data (green color)	

SOFTWARE FEATURES		ENVIRONMENTAL FEATURES		
Readable Codes	Interleaved 2/5 Code 39 standard Codabar Code 128 EAN 128 Code 93 (standard & full ASCII) EAN/UPC	Operating Temperature	0° to +40 °C (+32 to +104 °F)	
		Storage Temperature	-20° to +70 °C (-4° to +158 °F)	
		Humidity	90% non condensing	
		Vibration Resistance	IEC 68-2-6 test FC 1.5 mm; 10 to 55 Hz 2 hours on each axis	
Code Selection	Up to 10 codes during one reading phase	Shock Resistance	IEC 68-2-27 test EA 30 G; 11 ms 3 shocks on each axis	
Headers and Terminators	Up to 128-byte headers and 128-byte terminators		Protection Class	IP50
Operating Modes	On Line, Automatic, Test, PackTrack™	PHYSICAL FEATURES		
Config. Mode	Genius™ utility program		Std Models	Oscill. Mirror
Parameter Storage	Non-volatile internal FLASH	Dimensions mm (inch)	110x113x99 (4.33x4.45x3.9)	113x180x104.5 (4.45x7.08x4.11)
		Weight	1.5 kg (3.3 lb)	2.0 kg (4.4 lb)

Accessories:

Name	Description	Part Number
CAB-6011	Cable to C-BOX100 1 m	93A051221
CAB-6012	Cable to C-BOX100 2 m	93A051222
CAB-6015	Cable to C-BOX100 5 m	93A051223
C-BOX 100	Passive connection box	93ACC1510
INT-30	20 mA C.L. interface board for C-BOX 100	93A151022
GFC-60	90° mirror	93A201100
GFC-600	90° mirror close distance	93A201102
PWR-120	Power unit 110/230 V AC - 24 V DC	93ACC1530
BTK-6000	Terminator kit (5 pcs)	93ACC1710
PG6002	Single unit power supply – US	93ACC1718
PG6001	Single unit power supply – UK	93ACC1719
PG6000	Single unit power supply – EU	93ACC1720
FBK-6000	Fast bracket kit (2 pcs)	93ACC1721
US-60	Mounting bracket kit (5 pcs) for multisided stations	890001020
MEP-542	Photocell kit – PNP	93ACC1727
MEP-543	Photocell kit – NPN	93ACC1728

Electrical Connections:

The DS6500 Ethernet reader provides a 26-pin male D-sub connector for connection to power supply and input/output signals.

An Ethernet connector is used for connection to the remote Host (for ex. Remote PC connected via Internet), while a local Lonworks 9-pin female connector connects the Ethernet master to the first slave reader of the system.

The details of the connector pins are indicated in the following table:

26-pin D-Sub Connector Pinout				
Pin	Name	Function		
1	Shield	Internally connected by capacitor to chassis		
20	RXAUX	Receive data of auxiliary RS232 (referred to GND)		
21	TXAUX	Transmit data of auxiliary RS232 (referred to GND)		
8	OUT 1+	Configurable digital output 1 – positive pin		
22	OUT 1-	Configurable digital output 1 – negative pin		
11	OUT 2+	Configurable digital output 2 – positive pin		
12	OUT 2-	Configurable digital output 2 – negative pin		
16	OUT 3A	Configurable digital output 3 – polarity insensitive		
17	OUT 3B	Configurable digital output 3 – polarity insensitive		
18	EXT_TRIG A	External trigger (polarity insensitive)		
19	EXT_TRIG B	External trigger (polarity insensitive)		
6	IN2A	Input signal 2 (polarity insensitive)		
10	IN2B	Input signal 2 (polarity insensitive)		
14	IN3A	Input signal 3 (polarity insensitive)		
15	IN4A	Input signal 4 (polarity insensitive)		
24	IN_REF	Common reference of IN3 and IN4 (polarity insensitive)		
9, 13	VS	Supply voltage – positive pin		
23, 25, 26	GND	Supply voltage – negative pin		

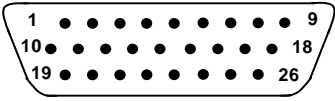

26-pin male D-sub Connector

Pin	RS232	RS485 Full-Duplex	RS485 Half-Duplex	20 mA C.L. (INT-30 with C-BOX 100 only)
2	TX	TX485+	RTX485+	see INT-30 instructions
3	RX	RX485+		
4	RTS	TX485-	RTX485-	
5	CTS	RX485-		
7	GND_ISO	GND_ISO	GND_ISO	

* For 20 mA C.L. connections, GND is the same of the scanner power supply.

9-pin Lonworks Connector Pinout		
Pin	Name	Function
1	Shield	Cable shield
9	VS	Supply voltage – positive pin
2	GND	Supply voltage – negative pin
6	VS_I/O	Supply voltage of I/O circuit
3	Ref_I/O	Reference voltage of I/O circuit
4	SYS_ENC_I/O	System signal
5	SYS_I/O	System signal
7	LON A	Lonworks line (polarity insensitive)
8	LON B	Lonworks line (polarity insensitive)

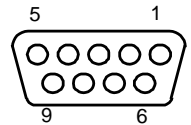

9-pin female Local Lonworks Connector

9-pin Profibus Connector		
Pin	Name	Function
1	Shield	Shield, Protective Ground resp. (optional)
2	Free	
3	B-LINE	Received/Transmitted Data-P
4	CNTR-P	Repeater Control Signal (optional, RS485 level)
5	DGND	Data Ground (M5V)
6	+5 V	Voltage Plus (P5V)
7	Free	
8	A-LINE	Received/Transmitted Data
9	CNTR-N	Repeater Control Signal

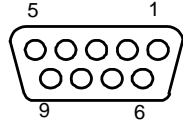

**9-pin female Profibus Connector
(white)**

Connectivity:

Point-to-Point Layout

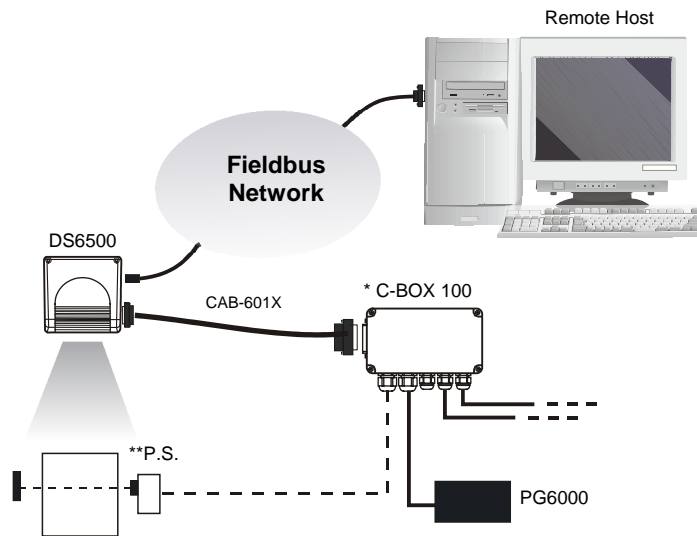

Pass Through Layout

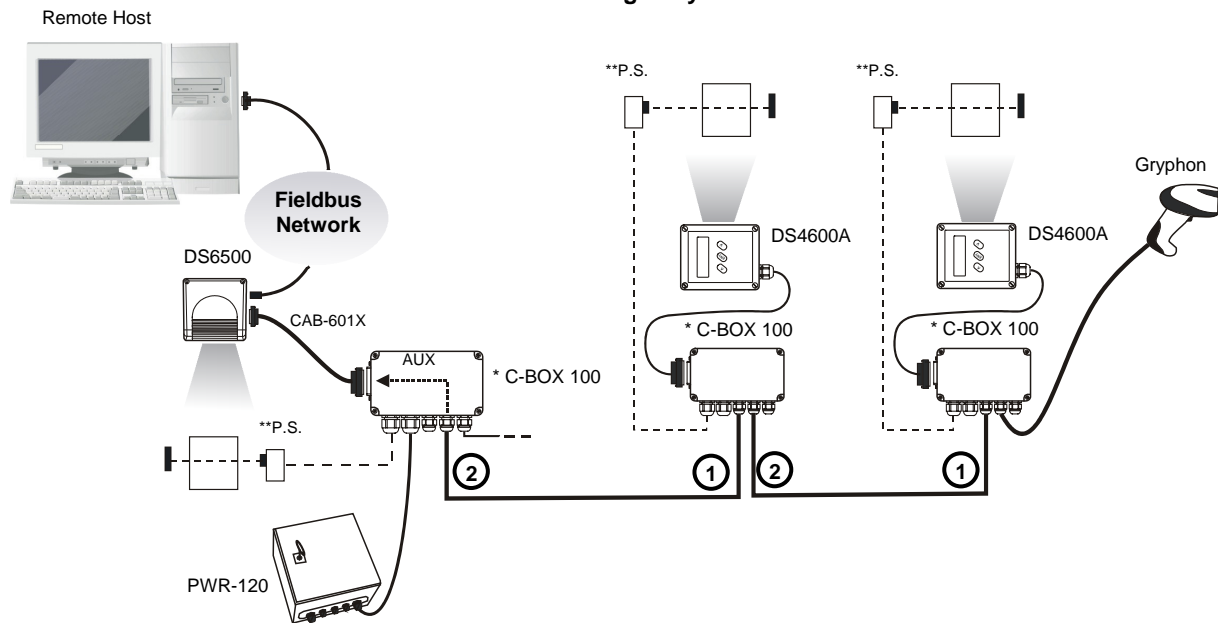

- ① Main Serial Interface
- ② Auxiliary Serial Interface

* C-BOX 100 can support up to 2 DS6500 readers. Please contact Datalogic USS Technical Support, if your application requires a multi-slave network.

** P.S. (Presence Sensor) connected to External Trigger input.

RS232 Master/Slave Layout

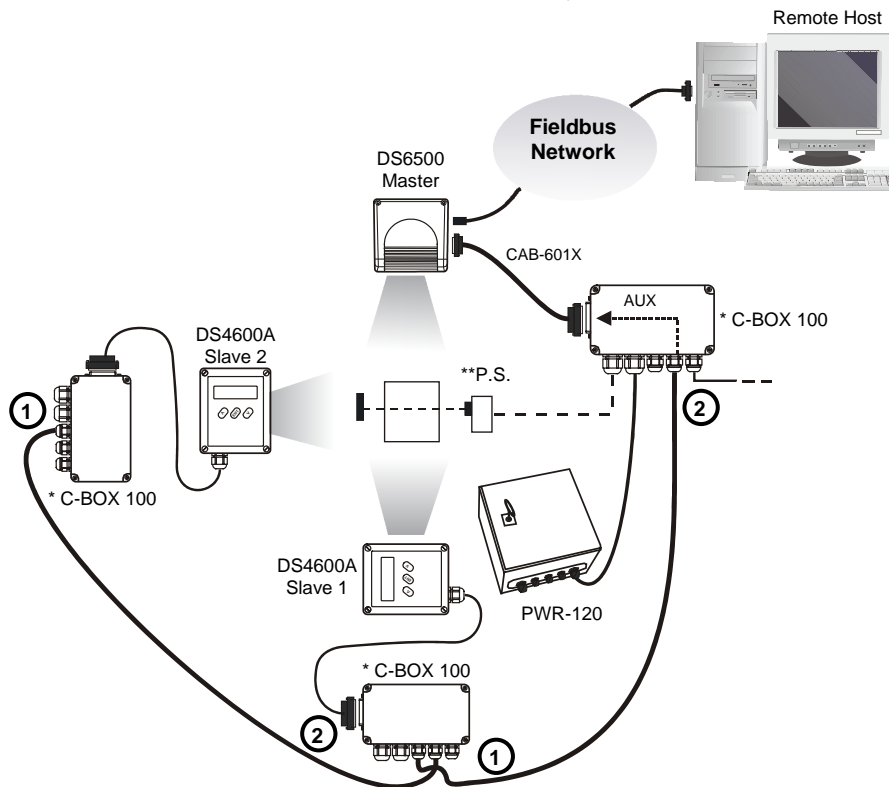

- ① Main Serial Interface
- ② Auxiliary Serial Interface

Profibus Network

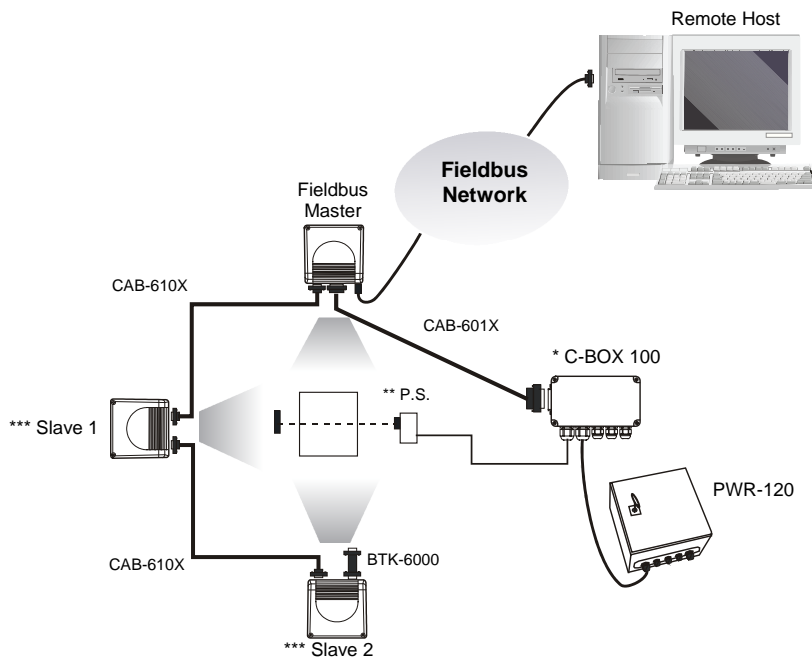

* C-BOX 100 can support up to 2 DS6500 readers. Please contact Datalogic USS Technical Support, if your application requires a multi-slave network.

** P.S. (Presence Sensor) connected to External Trigger input.

*** The Slave scanners are Master/Slave models which allow Lonworks network propagation.

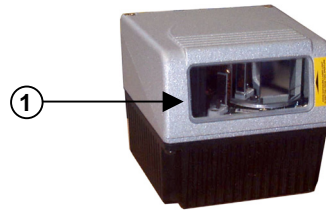

Figure A

① Laser Beam Output Window

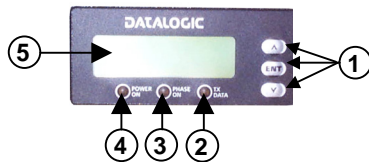

Figure B

- ① Programming Keypad
- ② TX Data LED (Green)
- ③ Phase On LED (Yellow)
- ④ Power On LED (Red)
- ⑤ LCD Display

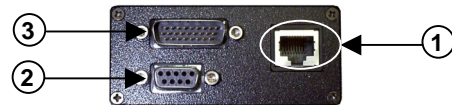
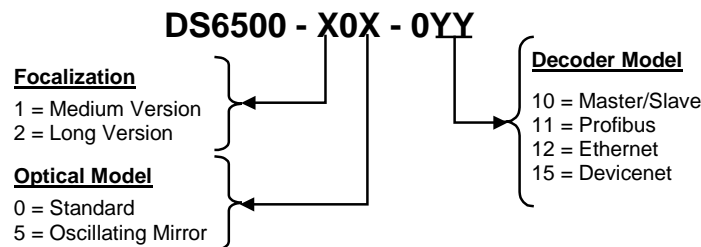

Figure C

- ① RJ45 Modular Connector for Ethernet Interface
- ② Lonworks 9-pin Female Connector
- ③ Main/Aux. Interface 26-pin D-Sub Male Connector

Available Models:



Technical Features:

ELECTRICAL FEATURES		OPTICAL FEATURES			
Supply Voltage	15 - 30 Vdc	Light Receiver	Avalanche photodiode		
Power Consumption	15 W typical 20 W Max. (including startup current)	Wavelength	630 to 680 nm		
Communication Interfaces	Main (isolated)	Baud Rate	Safety Class		
	RS232			1200 to 115200	Class 2-EN 60825-1; Class II-CDRH
	RS485 full-duplex				
	RS485 half-duplex	19200	Laser Control	Security system to turn laser off in case of motor slow down	
	20 mA C.L. (INT-30 with C-BOX 100 only)		READING FEATURES		
	Auxiliary	1200 to 115200	Scan Rate	600-1200 scans/s	
Other		Max. Resolution Max. Read. Distance Max. Read. Width Max. Depth of Field	(see reading diagram)		
Lonworks	1,25 Mb/s				
Ethernet	10 or 100 Mb/s				
Inputs		USER INTERFACE			
Ext. Trigger 1, 3 aux. digital inputs	(optocoupled NPN or PNP)	LCD Display	2 lines by 16 characters LCD		
Outputs		Keypad	3 keys		
3 software programmable digital outputs	(optocoupled)	LED Indicators	Power ON (red color) Phase ON (yellow color) TX Data (green color)		

SOFTWARE FEATURES		ENVIRONMENTAL FEATURES		
Readable Codes	Interleaved 2/5 Code 39 standard Codabar Code 128 EAN 128 Code 93 (standard & full ASCII) EAN/UPC	Operating Temperature	0° to +40 °C (+32 to +104 °F)	
		Storage Temperature	-20° to +70 °C (-4° to +158 °F)	
		Humidity	90% non condensing	
		Vibration Resistance	IEC 68-2-6 test FC 1.5 mm; 10 to 55 Hz 2 hours on each axis	
Code Selection	Up to 10 codes during one reading phase	Shock Resistance	IEC 68-2-27 test EA 30 G; 11 ms 3 shocks on each axis	
Headers and Terminators	Up to 128-byte headers and 128-byte terminators		Protection Class	IP50
Operating Modes	On Line, Automatic, Test, PackTrack™	PHYSICAL FEATURES		
Config. Mode	Genius™ utility program		Std Models	Oscill. Mirror
Parameter Storage	Non-volatile internal FLASH	Dimensions mm (inch)	110x113x99 (4.33x4.45x3.9)	113x180x104.5 (4.45x7.08x4.11)
		Weight	1.5 kg (3.3 lb)	2.0 kg (4.4 lb)

Accessories:

Name	Description	Part Number
CAB-6011	Cable to C-BOX100 1 m	93A051221
CAB-6012	Cable to C-BOX100 2 m	93A051222
CAB-6015	Cable to C-BOX100 5 m	93A051223
C-BOX 100	Passive connection box	93ACC1510
INT-30	20 mA C.L. interface board for C-BOX 100	93A151022
GFC-60	90° mirror	93A201100
GFC-600	90° mirror close distance	93A201102
PWR-120	Power unit 110/230 V AC - 24 V DC	93ACC1530
BTK-6000	Terminator kit (5 pcs)	93ACC1710
PG6002	Single unit power supply – US	93ACC1718
PG6001	Single unit power supply – UK	93ACC1719
PG6000	Single unit power supply – EU	93ACC1720
FBK-6000	Fast bracket kit (2 pcs)	93ACC1721
US-60	Mounting bracket kit (5 pcs) for multisided stations	890001020
MEP-542	Photocell kit – PNP	93ACC1727
MEP-543	Photocell kit – NPN	93ACC1728

Electrical Connections:

The DS6500 Ethernet reader provides a 26-pin male D-sub connector for connection to power supply and input/output signals.

An Ethernet connector is used for connection to the remote Host (for ex. Remote PC connected via Internet), while a local Lonworks 9-pin female connector connects the Ethernet master to the first slave reader of the system.

The details of the connector pins are indicated in the following table:

26-pin D-Sub Connector Pinout				
Pin	Name	Function		
1	Shield	Internally connected by capacitor to chassis		
20	RXAUX	Receive data of auxiliary RS232 (referred to GND)		
21	TXAUX	Transmit data of auxiliary RS232 (referred to GND)		
8	OUT 1+	Configurable digital output 1 – positive pin		
22	OUT 1-	Configurable digital output 1 – negative pin		
11	OUT 2+	Configurable digital output 2 – positive pin		
12	OUT 2-	Configurable digital output 2 – negative pin		
16	OUT 3A	Configurable digital output 3 – polarity insensitive		
17	OUT 3B	Configurable digital output 3 – polarity insensitive		
18	EXT_TRIG A	External trigger (polarity insensitive)		
19	EXT_TRIG B	External trigger (polarity insensitive)		
6	IN2A	Input signal 2 (polarity insensitive)		
10	IN2B	Input signal 2 (polarity insensitive)		
14	IN3A	Input signal 3 (polarity insensitive)		
15	IN4A	Input signal 4 (polarity insensitive)		
24	IN_REF	Common reference of IN3 and IN4 (polarity insensitive)		
9, 13	VS	Supply voltage – positive pin		
23, 25, 26	GND	Supply voltage – negative pin		

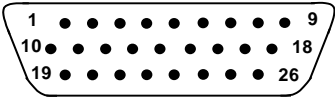

26-pin male D-sub Connector

Pin	RS232	RS485 Full-Duplex	RS485 Half-Duplex	20 mA C.L. (INT-30 with C-BOX 100 only)
2	TX	TX485+	RTX485+	see INT-30 instructions
3	RX	RX485+	RTX485-	
4	RTS	TX485-	RTX485-	
5	CTS	RX485-	GND_ISO	
7	GND_ISO	GND_ISO	GND_ISO	

* For 20 mA C.L. connections, GND is the same of the scanner power supply.

9-pin Lonworks Connector Pinout		
Pin	Name	Function
1	Shield	Cable shield
9	VS	Supply voltage – positive pin
2	GND	Supply voltage – negative pin
6	VS_I/O	Supply voltage of I/O circuit
3	Ref_I/O	Reference voltage of I/O circuit
4	SYS_ENC_I/O	System signal
5	SYS_I/O	System signal
7	LON A	Lonworks line (polarity insensitive)
8	LON B	Lonworks line (polarity insensitive)

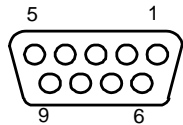

9-pin female Local Lonworks Connector

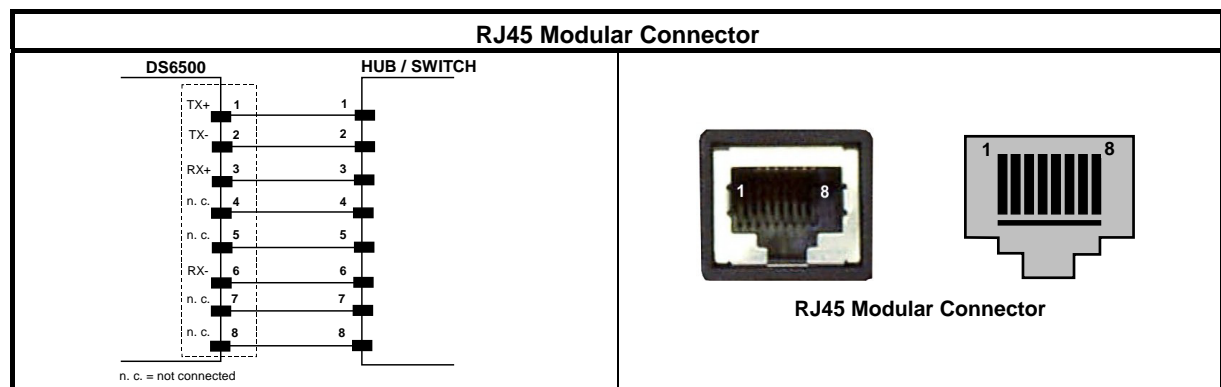

Connectivity:

Point-to-Point Layout

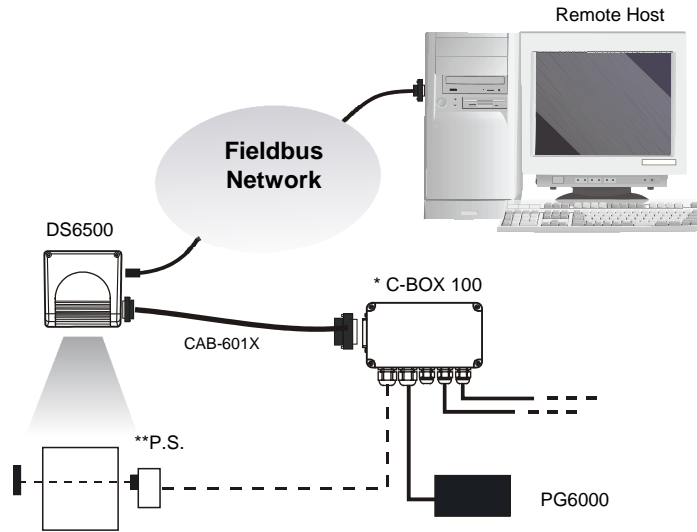

Pass Through Layout

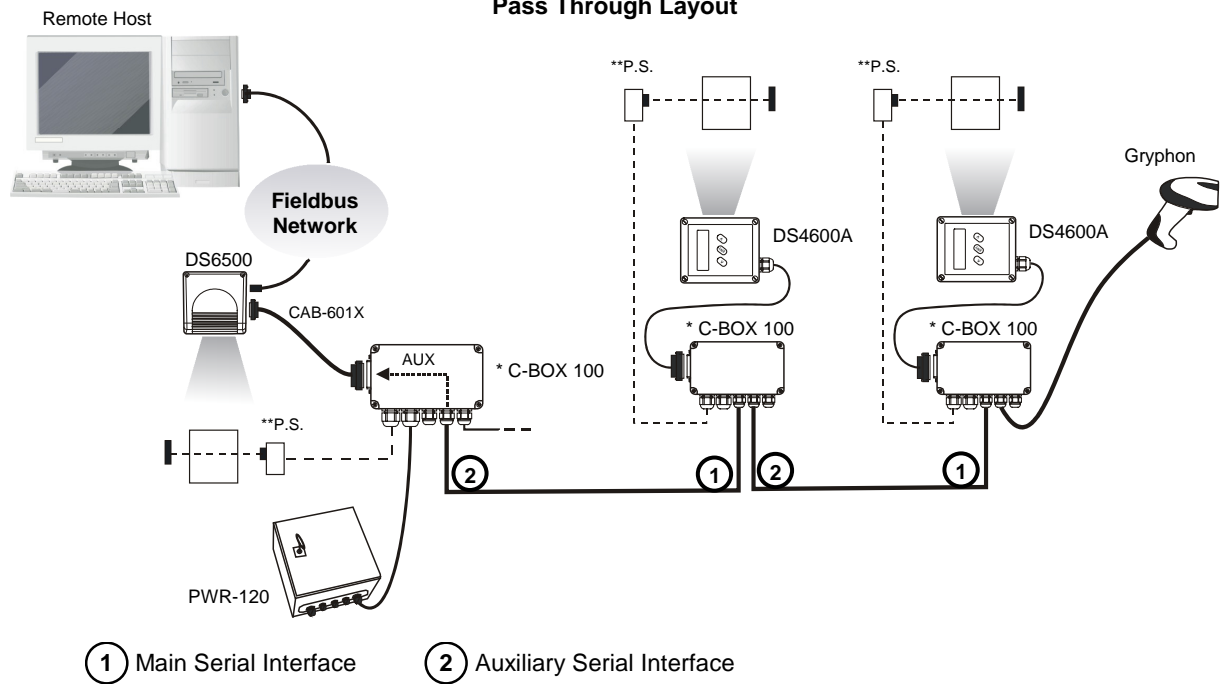

* C-BOX 100 can support up to 2 DS6500 readers. Please contact Datalogic USS Technical Support, if your application requires a multi-slave network.

** P.S. (Presence Sensor) connected to External Trigger input.

RS232 Master/Slave Layout

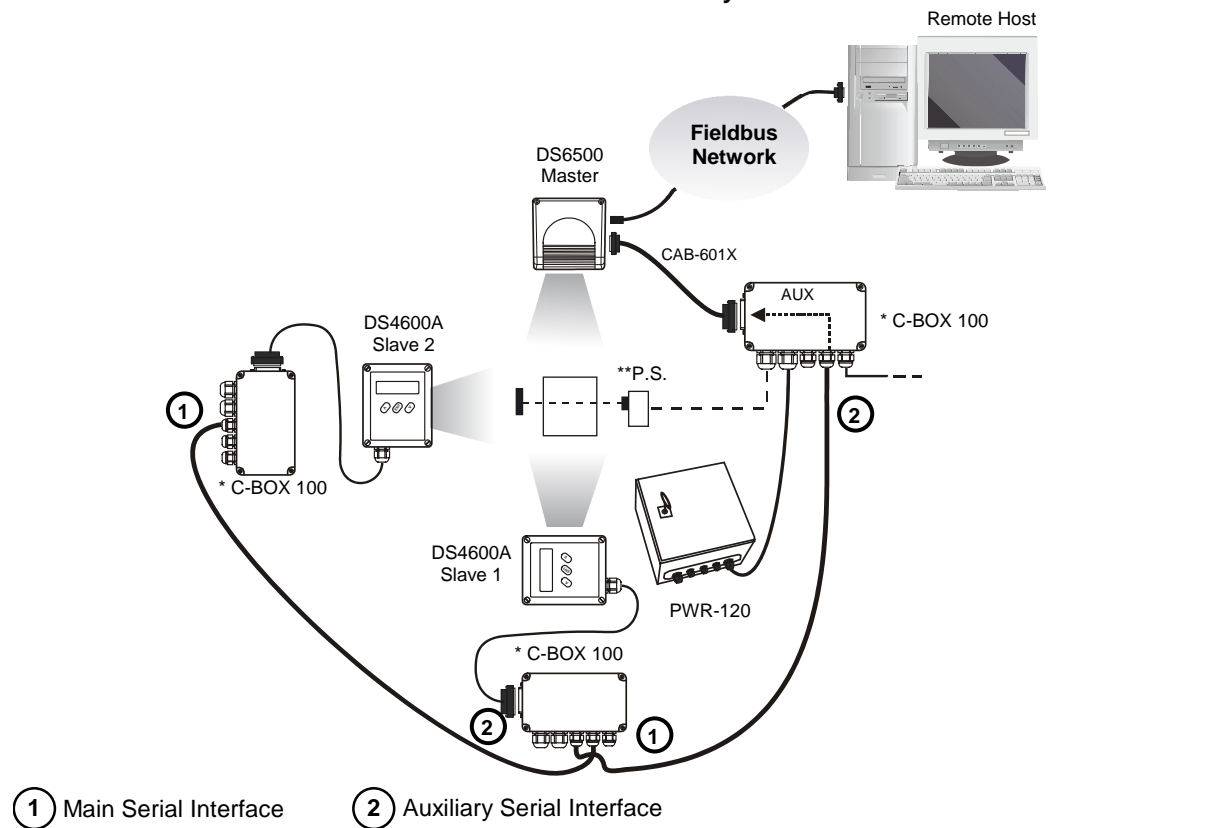

Ethernet Network

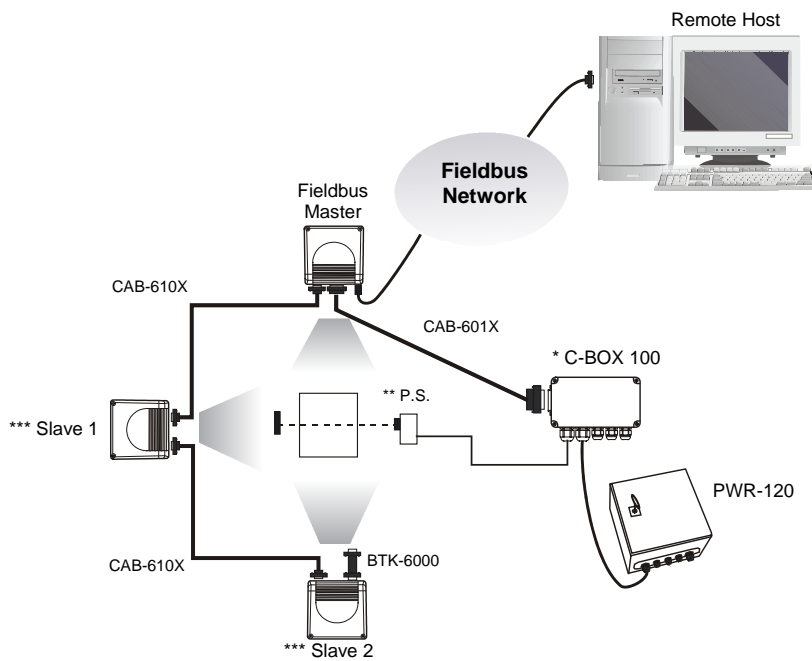

* C-BOX 100 can support up to 2 DS6500 readers. Please contact Datalogic USS Technical Support, if your application requires a multi-slave network.

** P.S. (Presence Sensor) connected to External Trigger input.

*** The Slave scanners are Master/Slave models which allow Lonworks network propagation.

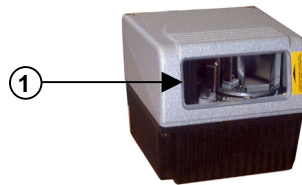

Figure A

① Laser Beam Output Window

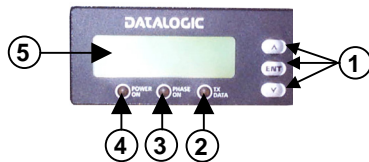

Figure B

- ① Programming Keypad
- ② TX Data LED (Green)
- ③ Phase On LED (Yellow)

- ④ Power On LED (Red)
- ⑤ LCD Display

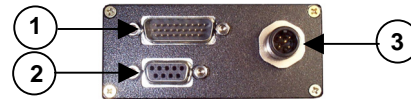
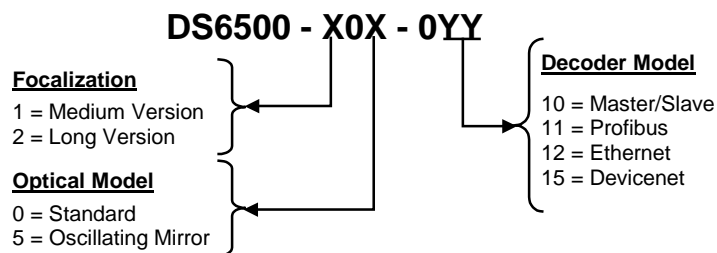

Figure C

- ① Main/Aux. Interface 26-pin D-sub Male Connector
- ② Lonworks 9-pin Female Connector
- ③ DeviceNet 5-pin Male Connector

Available Models:



Technical Features:

ELECTRICAL FEATURES		OPTICAL FEATURES		
Supply Voltage	15 - 30 Vdc	Light Receiver	Avalanche photodiode	
Power Consumption	15 W typical 20 W Max. (including startup current)	Wavelength	630 to 680 nm	
Communication Interfaces	Main (isolated)	Baud Rate	Laser Control Security system to turn laser off in case of motor slow down	
	RS232	1200 to 115200		
	RS485 full-duplex			
	RS485 half-duplex	19200		
	20 mA C.L. (INT-30 with C-BOX 100 only)			
	Auxiliary	RS232	1200 to 115200	
Inputs Ext. Trigger 1, 3 aux. digital inputs	(optocoupled NPN or PNP)		READING FEATURES	
			Scan Rate	600-1200 scans/s
			Max. Resolution	(see reading diagram)
			Max. Read. Distance	
Max. Read. Width Max. Depth of Field				

ELECTRICAL FEATURES		USER INTERFACE	
Outputs 3 software programmable digital outputs	(optocoupled)	LCD Display	2 lines by 16 characters LCD
		Keypad	3 keys
		LED Indicators	Power ON (red color) Phase ON (yellow color) TX Data (green color)
SOFTWARE FEATURES		ENVIRONMENTAL FEATURES	
Readable Codes	Interleaved 2/5 Code 39 standard Codabar Code 128 EAN 128 Code 93 (standard & full ASCII) EAN/UPC	Operating Temperature	0° to +40 °C (+32 to +104 °F)
Code Selection	Up to 10 codes during one reading phase	Storage Temperature	-20° to +70 °C (-4° to +158 °F)
Headers and Terminators	Up to 128-byte headers and 128-byte terminators	Humidity	90% non condensing
Operating Modes	On Line, Automatic, Test, PackTrack™	Vibration Resistance	IEC 68-2-6 test FC 1.5 mm; 10 to 55 Hz 2 hours on each axis
Config. Mode	Genius™ utility program	Shock Resistance	IEC 68-2-27 test EA 30 G; 11 ms 3 shocks on each axis
Parameter Storage	Non-volatile internal FLASH	Protection Class	IP64
		PHYSICAL FEATURES	
			Std Models Oscill. Mirror
		Dimensions mm (inch)	110x113x99 (4.33x4.45x3.9) 113x180x104.5 (4.45x7.08x4.11)
		Weight	1.5 kg (3.3 lb) 2.0 kg (4.4 lb)

Accessories:

Name	Description	Part Number
CAB-6011	Cable to C-BOX100 1 m	93A051221
CAB-6012	Cable to C-BOX100 2 m	93A051222
CAB-6015	Cable to C-BOX100 5 m	93A051223
C-BOX 100	Passive connection box	93ACC1510
INT-30	20 mA C.L. interface board for C-BOX 100	93A151022
GFC-60	90° mirror	93A201100
GFC-600	90° mirror close distance	93A201102
PWR-120	Power unit 110/230 V AC - 24 V DC	93ACC1530
BTK-6000	Terminator kit (5 pcs)	93ACC1710
PG6002	Single unit power supply – US	93ACC1718
PG6001	Single unit power supply – UK	93ACC1719
PG6000	Single unit power supply – EU	93ACC1720
FBK-6000	Fast bracket kit (2 pcs)	93ACC1721
US-60	Mounting bracket kit (5 pcs) for multisided stations	890001020
MEP-542	Photocell kit – PNP	93ACC1727
MEP-543	Photocell kit – NPN	93ACC1728

Electrical Connections:

The DS6500 DeviceNet reader provides a 26-pin male D-sub connector for connection to power supply and input/output signals.

A DeviceNet connector is used for connection to the remote Host, while a local Lonworks 9-pin female connector connects the DeviceNet master to the first slave reader of the system.



When using DeviceNet, the Main serial interface is disabled and must not be physically connected.

NOTE

The details of the connector pins are indicated in the following table:

26-pin D-Sub Connector Pinout				
Pin	Name	Function		
1	Shield	Internally connected by capacitor to chassis		
20	RXAUX	Receive data of auxiliary RS232 (referred to GND)		
21	TXAUX	Transmit data of auxiliary RS232 (referred to GND)		
8	OUT 1+	Configurable digital output 1 – positive pin		
22	OUT 1-	Configurable digital output 1 – negative pin		
11	OUT 2+	Configurable digital output 2 – positive pin		
12	OUT 2-	Configurable digital output 2 – negative pin		
16	OUT 3A	Configurable digital output 3 – polarity insensitive		
17	OUT 3B	Configurable digital output 3 – polarity insensitive		
18	EXT_TRIG A	External trigger (polarity insensitive)		
19	EXT_TRIG B	External trigger (polarity insensitive)		
6	IN2A	Input signal 2 (polarity insensitive)		
10	IN2B	Input signal 2 (polarity insensitive)		
14	IN3A	Input signal 3 (polarity insensitive)		
15	IN4A	Input signal 4 (polarity insensitive)		
24	IN_REF	Common reference of IN3 and IN4 (polarity insensitive)		
9, 13	VS	Supply voltage – positive pin		
23, 25, 26	GND	Supply voltage – negative pin		

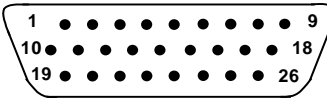

26-pin male D-sub Connector

Pin	RS232	RS485 Full-Duplex	RS485 Half-Duplex	20 mA C.L. (INT-30 with C-BOX 100 only)
2	TX	TX485+	RTX485+	see INT-30 instructions
3	RX	RX485+	RTX485+	
4	RTS	TX485-	RTX485-	
5	CTS	RX485-	RTX485-	
7	GND_ISO	GND_ISO	GND_ISO	

* For 20 mA C.L. connections, GND is the same of the scanner power supply.

9-pin Lonworks Connector Pinout		
Pin	Name	Function
1	Shield	Cable shield
9	VS	Supply voltage – positive pin
2	GND	Supply voltage – negative pin
6	VS_I/O	Supply voltage of I/O circuit
3	Ref_I/O	Reference voltage of I/O circuit
4	SYS_ENC_I/O	System signal
5	SYS_I/O	System signal
7	LON A	Lonworks line (polarity insensitive)
8	LON B	Lonworks line (polarity insensitive)

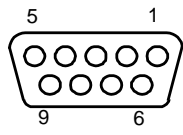

9-pin female Local Lonworks Connector

5-pin DeviceNet Connector Pinout		
Pin	Name	Function
2	V+	Supply voltage – positive pin
5	CAN_L	CAN bus data line – L
1	SHIELD	Shield
4	CAN_H	CAN bus data line – H
3	V-	Supply voltage – negative pin

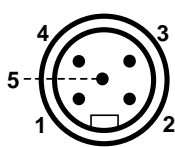

5-pin male DeviceNet Connector

 **NOTE** The power supplied on pin V+ and V- is used only to propagate power to the section of the DeviceNet board directly connected to the Bus. It is completely isolated from the DS6500 power which must be supplied on pin 9, 13 and pin 23, 25 of the 26-pin Main/Aux connector.

Connectivity:

Point-to-Point Layout

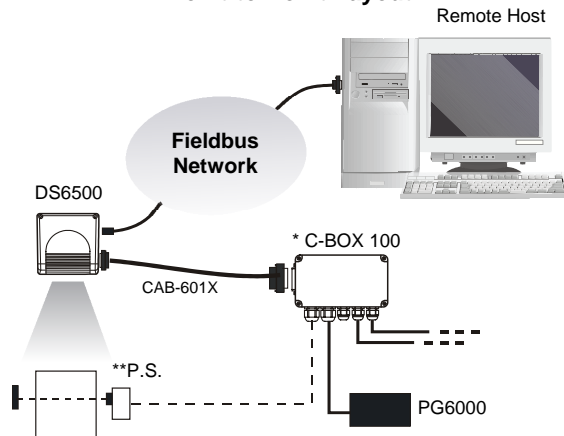

Pass Through Layout

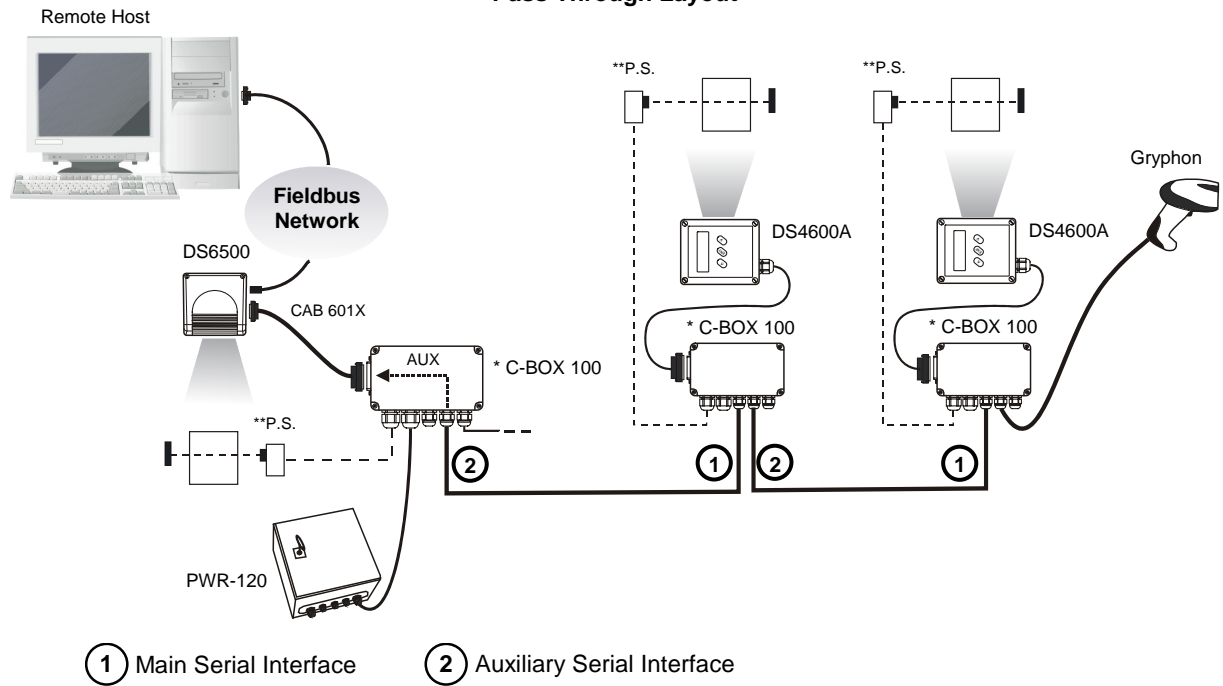

* C-BOX 100 can support up to 2 DS6500 readers. Please contact Datalogic USS Technical Support, if your application requires a multi-slave network.

** P.S. (Presence Sensor) connected to External Trigger input.

RS232 Master/Slave Layout

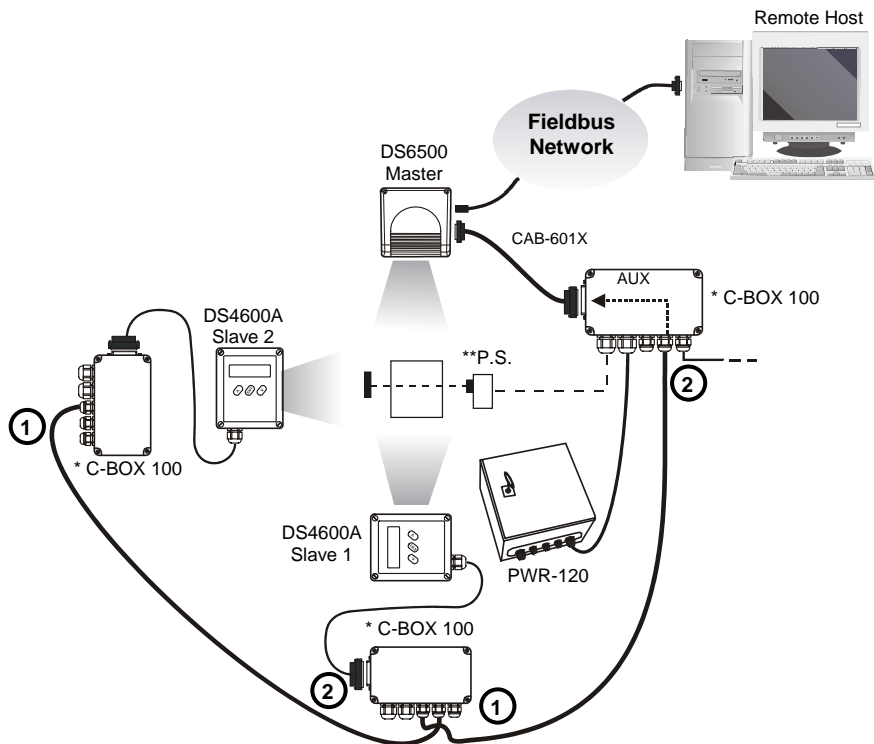

① Main Serial Interface

② Auxiliary Serial Interface

DeviceNet Network

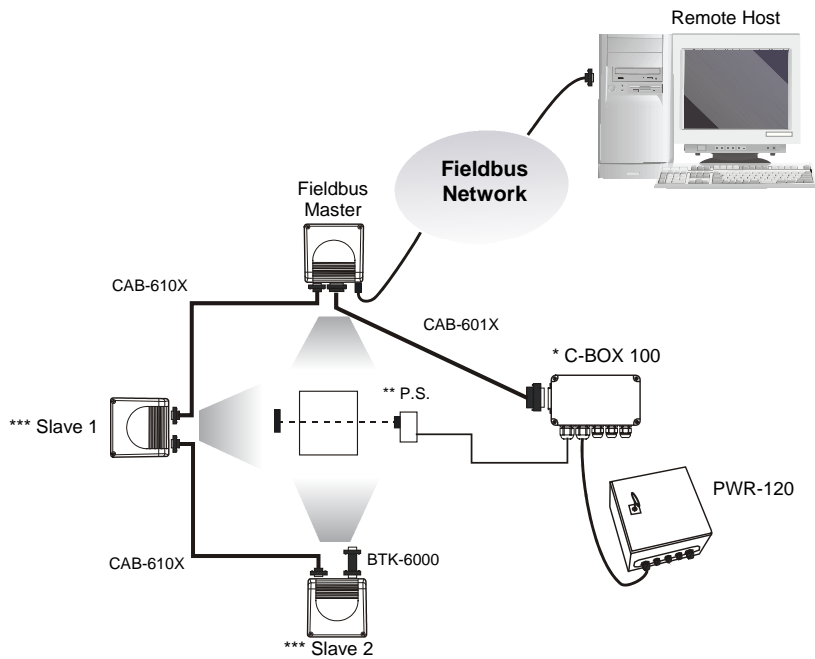

* C-BOX 100 can support up to 2 DS6500 readers. Please contact Datalogic USS Technical Support, if your application requires a multi-slave network.

** P.S. (Presence Sensor) connected to External Trigger input.

*** The Slave scanners are Master/Slave models which allow Lonworks network propagation.

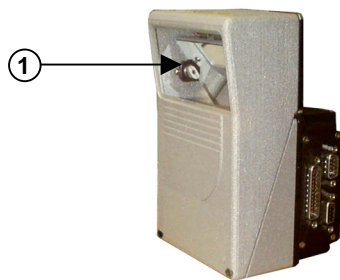

Figure A

① Laser Beam Output Window

Oscillating mirror models are used when coverage of a large reading area is required, mainly in picket fence applications.

The DS6500 scanner mounts a dedicated optic head with integrated oscillating mirror driven by a linear motor.

The speed, precision, repeatability, and reliability of this driving technology assure high level performance.

The new oscillating mirror is completely software controlled and software programmable. The Genius™ software tool allows adjusting the linear motor speed (oscillating frequency) and the upper and lower limits of the oscillation by defining the top and bottom line limit angles.

When the oscillating mirror is programmed to read barcode labels at very small angles, position the reader to **assure at least 10°** for the Skew angle (see DS6500 Reference Manual). This angle refers to the most inclined or external laser line, so that all other laser lines assure more than 10° Skew. This avoids the direct reflection of the laser light emitted by the reader.

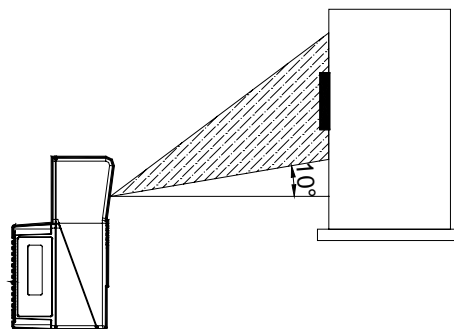

Oscillating Mirror Skew Angle

Otherwise, the scanner can be mounted at an angle of inclination of 17.5° in order to attain symmetrical deflection ranges.

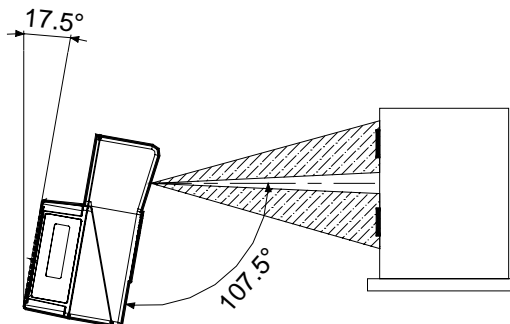

Oscillating Mirror Reading Position

In the above case, the zone where the scan line is perpendicular to the reflecting surface corresponds to a neutral zone at the center of the reading field.

The mirror can be deflected up to 40°. Oscillation with respect to the output window median axis is asymmetrical (see figure below).



Oscillating Mirror Maximum Aperture and Asymmetry

By configuring the oscillating speed up to the maximum value of 19 Hz, raster emulation can be performed for reading fast moving objects.

Hz	Max. Aperture
0-5	40°
6-10	30°
11-15	20°
16-19	10°



NOTE

By limiting the raster width to the minimum necessary, the number of scans on the reading surface is increased.

Oscillating angles are selected in software where the minimum and maximum angles correspond to -2.5° and +37.5°.

The scanner can be tilted in order for the 17.5° software setting to correspond with the 0° horizontal plane.

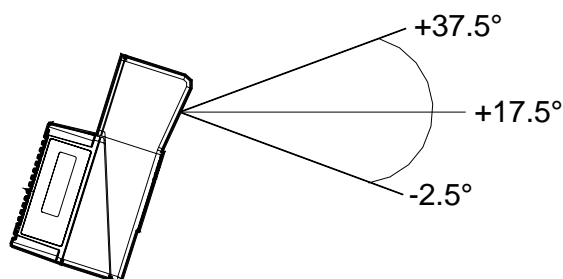

Oscillating Mirror Extreme Angle Positions

These models provide higher scanning speed (1200 scans/sec) compared to standard models and the reading performance is not adversely effected by the oscillating mirror.

The example represents the selection of an angle of +10° for the bottom line and an angle of +20° for the top line (see figure beside).

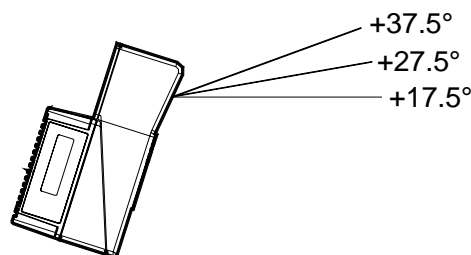

Oscillating Mode

C-BOX 100 Pinout for DS6500:

The table below gives the pinout of the C-BOX 100 terminal block connectors. Use this pinout when the DS6500 reader is connected in a network by means of the C-BOX 100:

C-BOX 100 Terminal Block Connectors				
Power				
1, 3, 5	VS			
2, 4, 6	GND			
7, 8	EARTH GROUND			
20, 40	Reserved			
Inputs				
27	EXT TRIG A (polarity insensitive)			
28	EXT TRIG B (polarity insensitive)			
29	IN 2A (polarity insensitive)			
30	IN 2B (polarity insensitive)			
31, 33	IN 3A (polarity insensitive)			
32, 34	IN 4A (polarity insensitive)			
36	IN 3B/IN 4B Reference (polarity insensitive)			
Outputs				
21	OUT 1+			
22	OUT 1-			
23	OUT 2+			
24	OUT 2-			
25	OUT 3A (polarity insensitive)			
26	OUT 3B (polarity insensitive)			
Auxiliary Interface				
35	TX AUX			
37	RX AUX			
38, 39	GND			
Main Interface				
	RS232	RS485 Full-Duplex	RS485 Half-Duplex	20 mA C.L. (with INT-30 only)
11, 15	TX 232	TX 485+	RTX 485+	
12, 16	RTS 232	TX 485-	RTX 485-	
17	RX 232	RX 485+		see INT-30
18	CTS 232	RX 485-		instructions
10, 14, 19	SGND Main Isolated	SGND Main Isolated	SGND Main Isolated	
9, 13		RS485 Cable Shield	RS485 Cable Shield	

Mechanical Installation:

The DS6500 reader can be positioned and installed in the best way possible as a result of the Step-A-Head™ feature. Thanks to the separation between Head and Base, you can modify the orientation of the decoder base, and therefore display-keypad and connector panels, while keeping the optic head in the correct reading position. The reading head and the decoder base can be rotated independently from each other allowing the installation even in the most critical locations.

To rotate the head follow the given procedure:

1. detach the head from the base by unscrewing the four fixing screws;
2. rotate the head in the desired position;
3. loosen but don't remove the two screws on top of the head;
4. affix the head onto the base carefully aligning the four fixing screws and progressively tightening them about half-way;
5. completely tighten the two screws on top of the head;
6. completely tighten the four fixing screws.

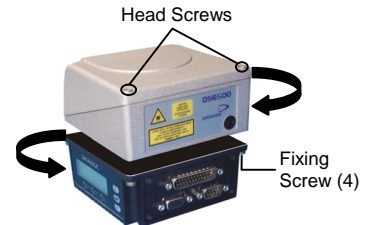

Step-A-Head™ Feature

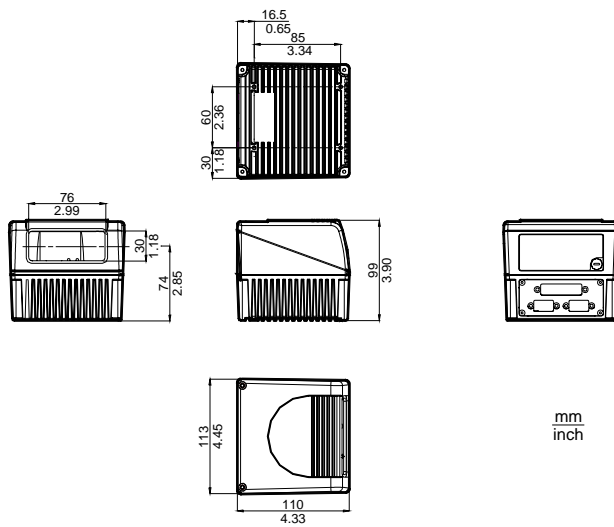

DS6500 Overall Dimensions

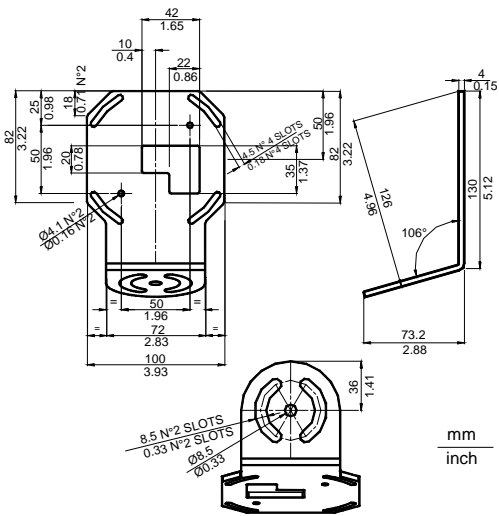

ST-237 Mounting Bracket Overall Dimensions

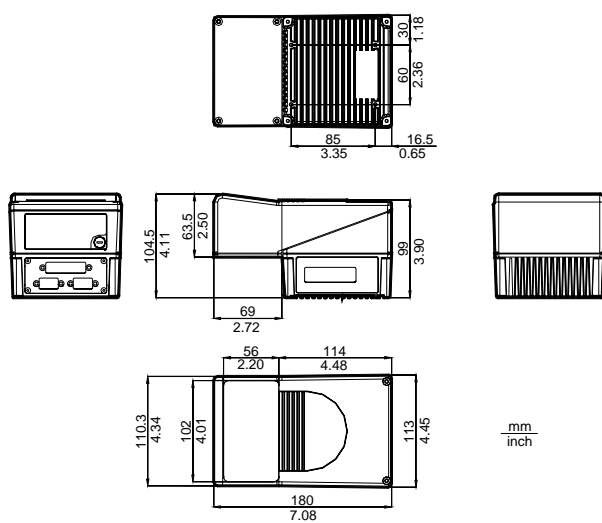

DS6500 Oscillating Mirror Model Overall Dimensions

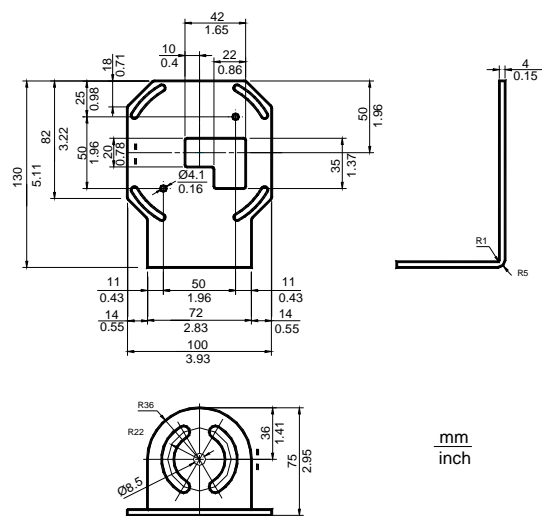

ST-210 Mounting Bracket Overall Dimensions

Typical Installations:

Standard Installation

The DS6500 scanner is mounted on the ST-237 106° mounting bracket which guarantees a built-in Skew angle (**S** in the figure below) of 16° with respect to the frame plane (typically the Skew angle should be between 10° - 20°). This avoids the direct reflection of the laser light emitted by the scanner. Furthermore, the bracket guides allow adjusting the Tilt angle (**T** in the figure below, which is typically 0°) for the best scanner orientation:

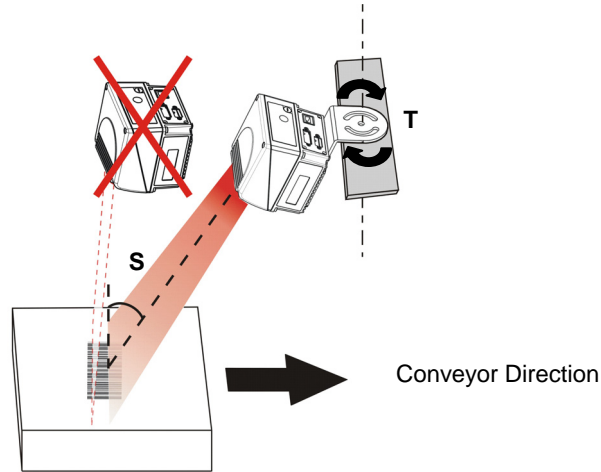

"45° Skew" Installation

The DS6500 scanner is mounted on the ST-210 90° mounting bracket. By adjusting the mounting bracket guides, reach 45° for the Skew angle (**S** in the figure below) to avoid the direct reflection of the laser light emitted by the scanner:

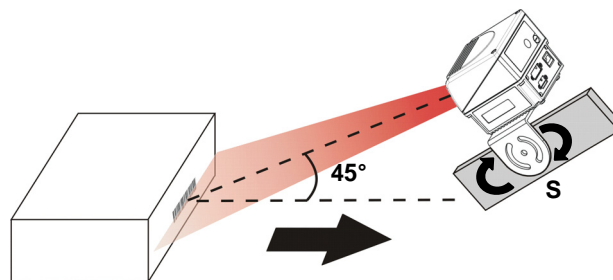

ATTENTION

If using the "45° Skew" installation, it is not guaranteed that the scanner reading performances (see reading diagram section) will match those measured for the standard installation with Skew angle between 10° - 20°.



NOTE

The ST-210 mounting bracket is an accessory of the DS6500 standard model available in the US-60 kit (order no. 890001020).

ASTRA™:

Automatically SwITched Reading Area™ is the new Datalogic technology based on a multi-laser architecture and a fixed mounted optic system which concentrates the multiple laser emissions in a single laser beam. As each laser emitter is focused on a specific range of the reading area, a sophisticated electronic controller selects the best focused laser emitter with respect to the code read. This allows the reading of medium-high density codes in a large reading area on very fast conveyors.

PackTrack™:

PackTrack™ is a patented operating mode for Datalogic Omni-Directional Reading Stations used to read and correctly assign codes read on different packs when placed in the scanner Reading Area at the same time. Working in PackTrack™ mode requires the presence of an encoder and a presence sensor to track the moving packs.

All PackTrack™ functionalities are programmed via the Genius™ tool (refer to the Genius™ Help On-Line for details).

In fact, in the following example, the codes of two or more consecutive packs are found at the same time in the scanner reading area. Therefore, the condition occurs where, in the sequence of the two packs, the code of the second pack is read first, just before the code of the previous pack. A system without PackTrack™ would assign the code of the second pack to first pack and vice versa, thus causing a gross error in sortation.

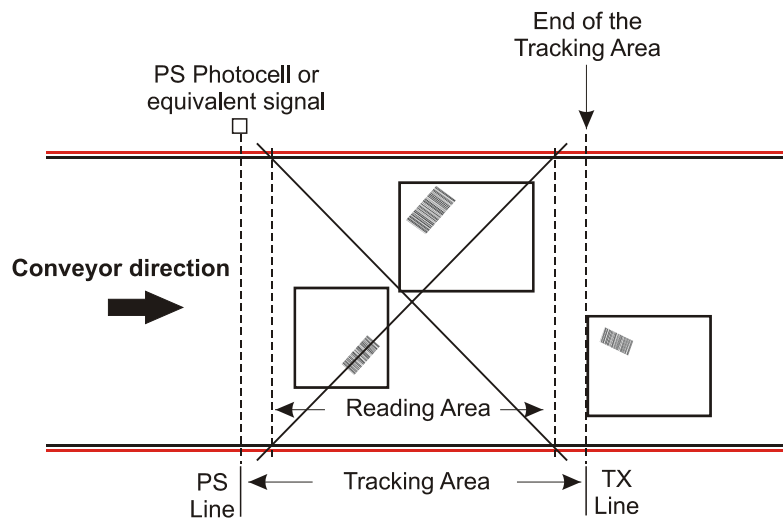

Reading Diagrams:

In the following reading diagrams (0,0) is the center of the laser beam output window.

DS6500-100-0XX

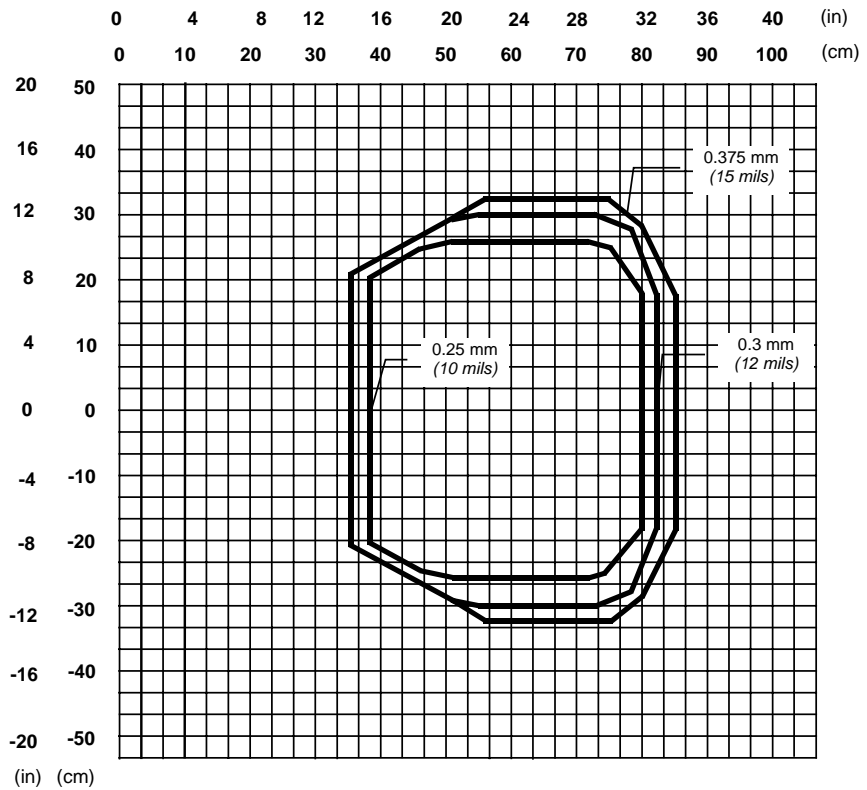

CONDITIONS

Code = Interleaved 2/5 or Code 39

PCS = 0.90

Pitch angle = 0°

Skew angle = 10° - 20°

Tilt angle = 0°

DS6500-105-0XX

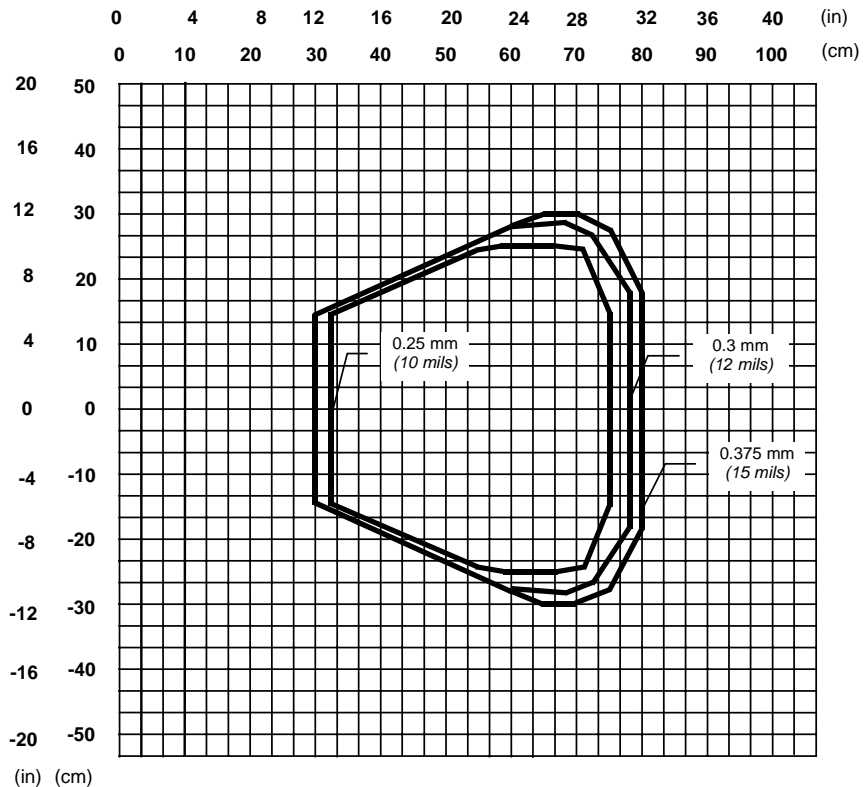

CONDITIONS

Code = Interleaved 2/5 or Code 39

PCS = 0.90

Pitch angle = 0°

Skew angle = 10° - 20°

Tilt angle = 0°

Reading Diagrams:

DS6500-200-0XX

0	14	20	26	32	38	44	50	56	62	68	(in)
0	35	50	65	80	95	110	125	140	155	170	(cm)

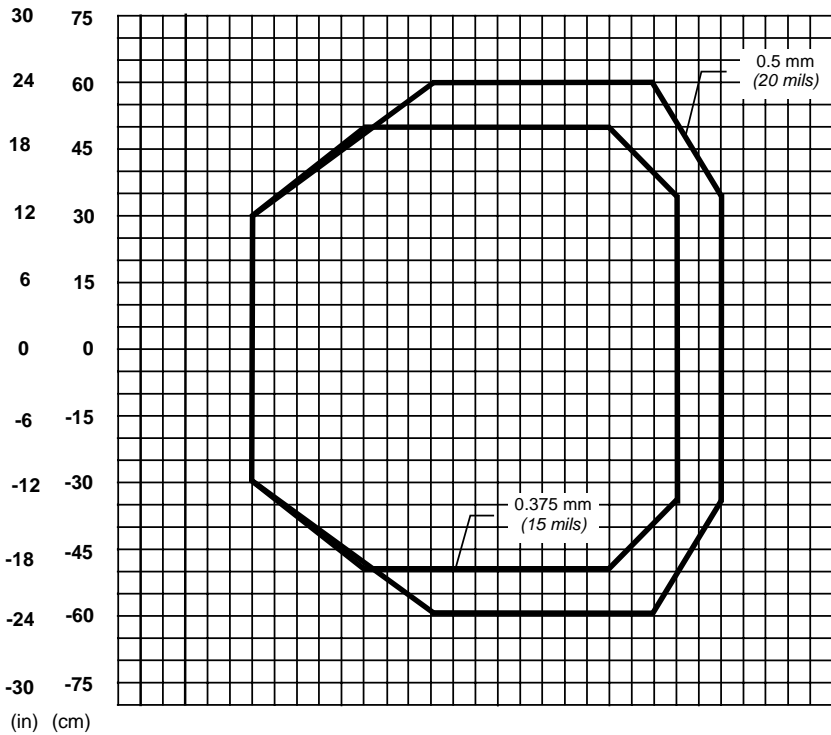

CONDITIONS

Code = Interleaved 2/5 or Code 39
 PCS = 0.90
 Pitch angle = 0°
 Skew angle = 10° - 20°
 Tilt angle = 0°

DS6500-205-0XX

0	14	20	26	32	38	44	50	56	62	68	(in)
0	35	50	65	80	95	110	125	140	155	170	(cm)

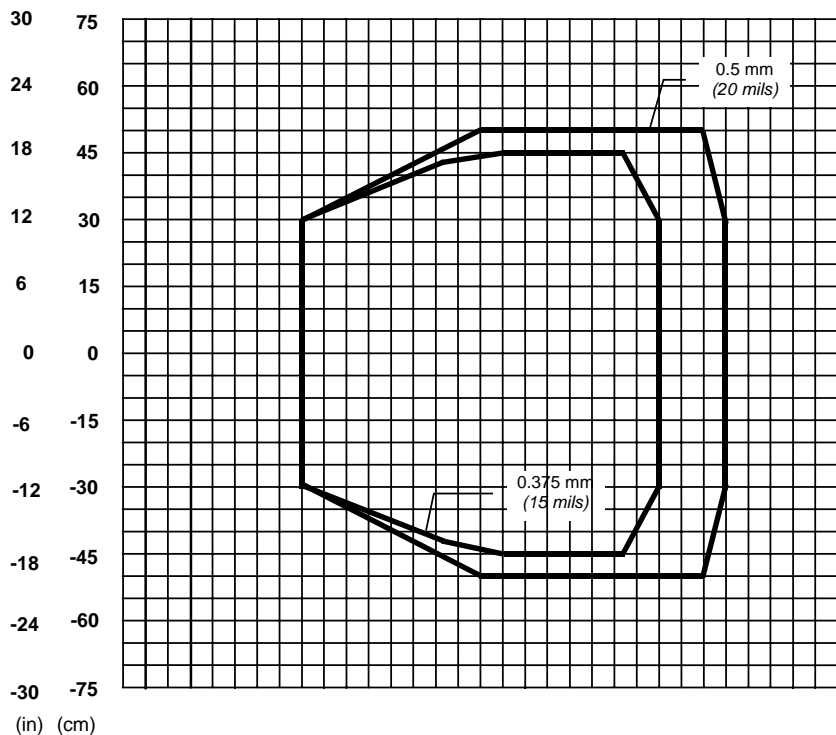

CONDITIONS

Code = Interleaved 2/5 or Code 39
 PCS = 0.90
 Pitch angle = 0°
 Skew angle = 10° - 20°
 Tilt angle = 0°

User Interface:

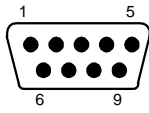
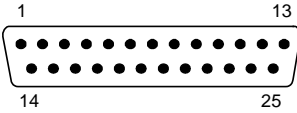
RS232 PC-side connections			
 <p>9-pin male connector</p>		 <p>25-pin male connector</p>	
Pin	Name	Pin	Name
2	RX	3	RX
3	TX	2	TX
5	GND	7	GND
7	RTS	4	RTS
8	CTS	5	CTS

How To Build A Simple Interface Test Cable:

The following wiring diagram shows a simple test cable including power, external (push-button) trigger and PC RS232 COM port connections.

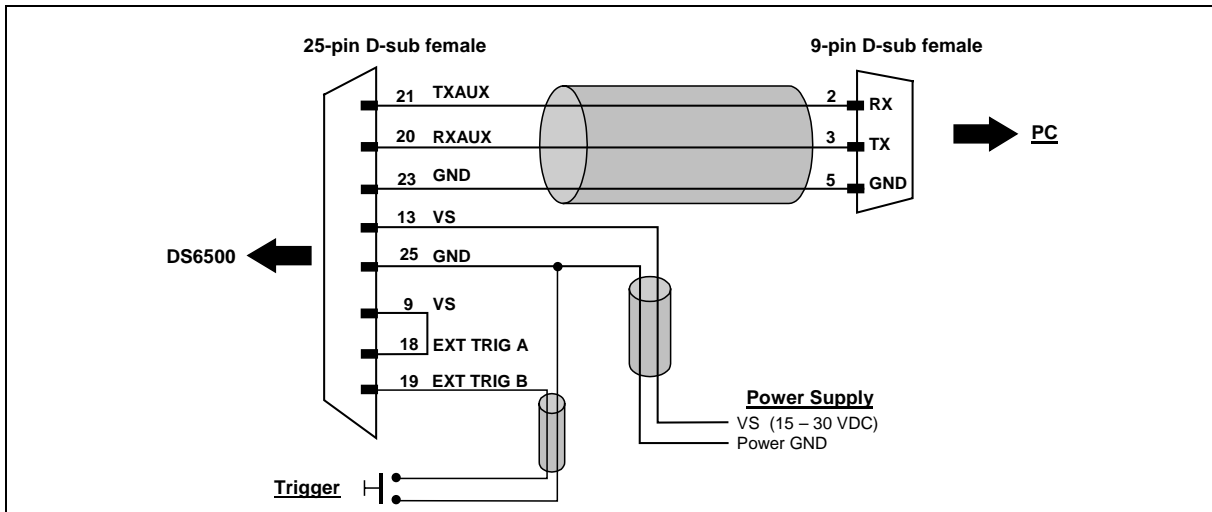

Safety Precautions

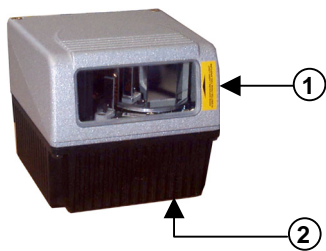

Figure A

- ① Laser Safety Label
- ② Identification Label

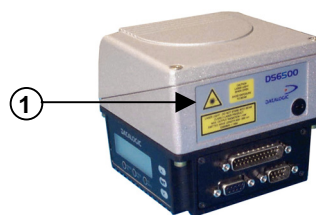

Figure B

- ① Warning and Device Class Label

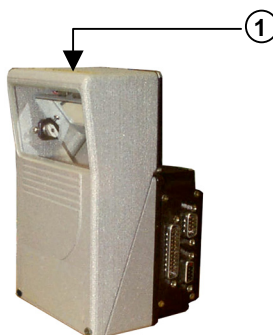

Figure C

- ① Laser Safety Label

The scanner is classified as a Class 2 laser product according to EN 60825-1 regulations and as a Class II laser product according to CDRH regulations.

Disconnect the power supply when opening the device during maintenance or installation to avoid exposure to hazardous laser light.

There is a safety device which allows the laser to be switched on only if the motor is rotating above the threshold for its correct scanning speed.

The laser beam can be switched off through a software command (see also the Genius™ Help On-Line).

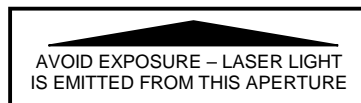

Laser Safety Label for Oscillating Mirror and Standard Models

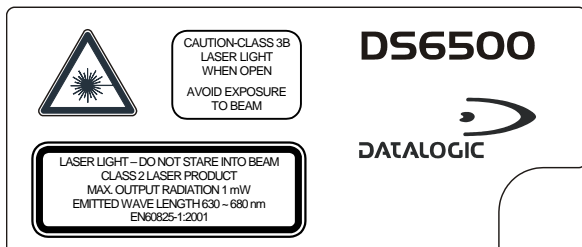

Warning and Device Class Label

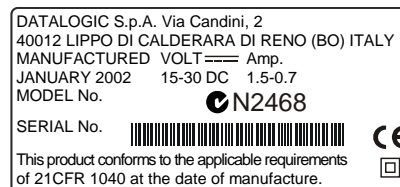

Device Identification Label

The laser diode used in this device is classified as a Class 3B laser product according to EN 60825-1 regulations and as a Class IIIb laser product according to CDRH regulations. As it is not possible to apply a classification label on the laser diode used in this device, the following label is reproduced below:

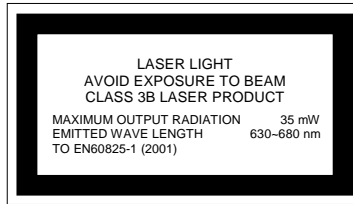

Laser Diode Class Label

Any violation of the optic parts in particular can cause radiation up to the maximum level of the laser diode (35 mW at 630 ~ 680 nm).

Power Supply

- **This product is intended to be installed by Qualified Personnel only.**
- **All DS6500 Models:**
This device is intended to be supplied by a UL Listed Power Unit marked "Class 2" or LPS power source which supplies power directly to the scanner via the 25/26-pin connector.

dichiara che
declares that the
déclare que le
bescheinigt, daß das Gerät
declare que el

DS6500-XXX-XXX, Laser Scanner e tutti i suoi modelli
and all its models
et tous ses modèles
und seine modelle
y todos sus modelos

sono conformi alle Direttive del Consiglio Europeo sottoelencate:
are in conformity with the requirements of the European Council Directives listed below:
sont conformes aux spécifications des Directives de l'Union Européenne ci-dessous:
den nachstehenden angeführten Direktiven des Europäischen Rats:
cumple con los requisitos de las Directivas del Consejo Europeo, según la lista siguiente:

89/336/EEC EMC Directive	e and et und y	92/31/EEC, 93/68/EEC	emendamenti successivi further amendments ses successifs amendements späteren Abänderungen sucesivas enmiendas
---------------------------------	----------------------------	-----------------------------	--

73/23/ECC Low Voltage Directive

Basate sulle legislazioni degli Stati membri in relazione alla compatibilità elettromagnetica ed alla sicurezza dei prodotti.
On the approximation of the laws of Member States relating to electromagnetic compatibility and product safety.
Basée sur la législation des Etats membres relative à la compatibilité électromagnétique et à la sécurité des produits.
Über die Annäherung der Gesetze der Mitgliedsstaaten in bezug auf elektromagnetische Verträglichkeit und Produktsicherheit entsprechen.
Basado en la aproximación de las leyes de los Países Miembros respecto a la compatibilidad electromagnética y las Medidas de seguridad relativas al producto.

Questa dichiarazione è basata sulla conformità dei prodotti alle norme seguenti:
This declaration is based upon compliance of the products to the following standards:
Cette déclaration repose sur la conformité des produits aux normes suivantes:
Diese Erklärung basiert darauf, daß das Produkt den folgenden Normen entspricht:
Esta declaración se basa en el cumplimiento de los productos con las siguientes normas:

EN 55022, August 1994:	LIMITS AND METHODS OF MEASUREMENTS OF RADIO DISTURBANCE CHARACTERISTICS OF INFORMATION TECHNOLOGY EQUIPMENT (ITE)
EN 61000-6-2, October 2001:	ELECTROMAGNETIC COMPATIBILITY (EMC). PART 6-2: GENERIC STANDARDS - IMMUNITY FOR INDUSTRIAL ENVIRONMENTS
EN 60950-1, December 2001:	INFORMATION TECHNOLOGY EQUIPMENT – SAFETY – PART 1: GENERAL REQUIREMENTS
EN 60825-1, June 1994: AMENDMENTS A11 (1996), A2 (2001)	SAFETY OF LASER PRODUCTS PART 1: EQUIPMENT CLASSIFICATION, REQUIREMENTS AND USER'S GUIDE

Lippo di Calderara, 14/09/2004

Ruggero Cacioppo
Ruggero Cacioppo
Quality Assurance Laboratory Manager