

DS4600A Laser Barcode Reader Quick Reference Guide

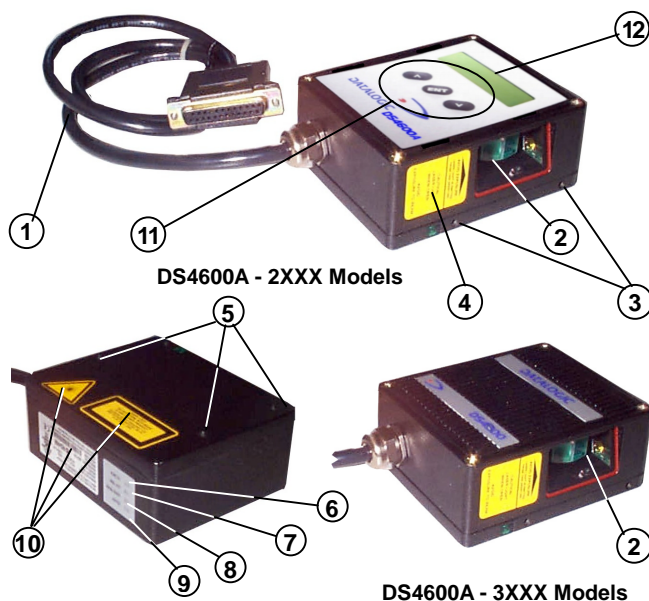

Figure A

- | | |
|-------------------------------|-------------------------------------|
| ① Cable with 25-pin Connector | ⑦ External Trigger LED |
| ② Laser Beam Output Window | ⑧ Good Read LED |
| ③ Accessory Mounting Holes | ⑨ Ready LED |
| ④ Warning Label | ⑩ Warning and Classification Labels |
| ⑤ Mounting Holes | ⑪ Keypad |
| ⑥ Data TX LED | ⑫ Display |

For further details on product installation, see the complete Installation Manual available on the WinHost CD included with this product.

POWER SUPPLY

- This product is intended to be installed by Qualified Personnel only.
- **Models DS4600A-XXX0:**
This device is intended to be supplied by a UL Listed Direct Plug-in Power Unit marked "Class 2", rated 10-30 V minimum, 0.60 A.
This device may also be supplied by a UL Listed Power Unit marked "Class 2" or LPS power source which supplies power directly to the scanner via the 25-pin connector.
- **Model DS4600A-2XX5:**
This device is intended to be supplied by a UL Listed Direct Plug-in Power Unit marked "Class 2", rated 24 V minimum, 0.50 A.
This device may also be supplied by a UL Listed Power Unit marked "Class 2" or LPS power source which supplies power directly to the scanner via the 25-pin connector.

The scanner is classified as a Class 2 laser product according to EN 60825-1 regulations and as a Class II laser product according to CDRH regulations.

For installation, use and maintenance it is not necessary to open the device.

There is a safety device which allows the laser to be switched on only if the motor is rotating above the threshold for its correct scanning speed.

The laser beam can be switched off through a software command (see also the WinHost Help On-Line).

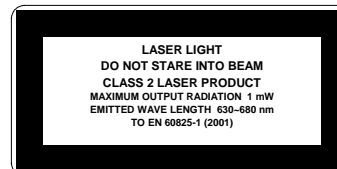
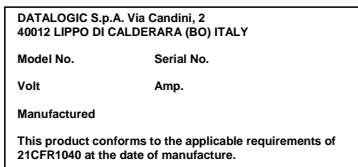
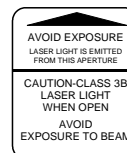

Warning and device class labels

The laser diode used in this device is classified as a class 3B laser product according to EN 60825-1 regulations and as a Class IIIb laser product according to CDRH regulations. As it is not possible to apply a classification label on the laser diode used in this device, the following label is reproduced below.

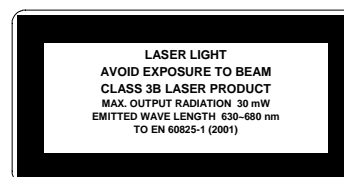

Laser diode class label

Any violation of the optic parts in particular can cause radiation up to the maximum level of the laser diode (30 mW at 630 to 680 nm).



Available Models:

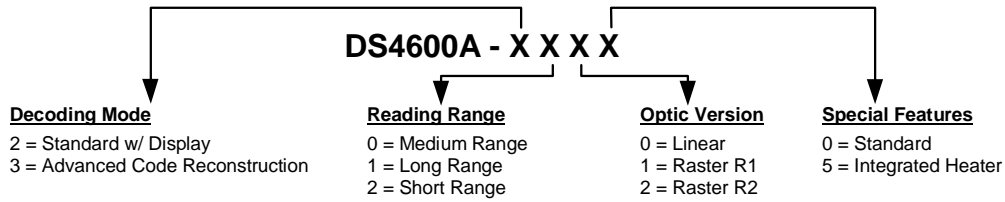

The following table displays each version's reading performance.

| Version | Reading Distance | Max Code Resolution mm (mils) | Speed scans/s |
|---------|--|----------------------------------|------------------|
| 210X | 200 mm (8 in) - 980 mm (39 in) on 1.00 mm (40 mils) codes | 0.50 (20) | 800 |
| 200X | 160 mm (6 in) - 540 mm (21 in) on 0.50 mm (20 mils) codes | 0.25 (10) | 800 |
| 220X | 50 mm (1.97 in) - 400 mm (15.75 in) on 0.80 mm (31 mils) codes | 0.20 (8) | 800 |
| 310X | 200 mm (8 in) - 970 mm (38 in) on 1.00 mm (40 mils) codes | 0.50 (20) | 800 |
| 300X | 160 mm (6 in) - 540 mm (21 in) on 0.50 mm (20 mils) codes | 0.25 (10) | 800 |
| 320X | 120 mm (4.7 in) - 310 mm (12.2 in) on 0.30 mm (12 mils) codes | 0.20 (8) | 800 |

| ELECTRICAL FEATURES | | SOFTWARE FEATURES | |
|-----------------------------------|--|--------------------------------|--|
| Power Supply | Model XXX0: 10 -30 Vdc Model 2XX5: 24 Vdc | Readable Codes | EAN/UPC (including Add-on 2 and Add-on 5) Code 39 2/5 Interleaved Code 128 EAN 128 Code 93 Codabar Pharmacode |
| Power Consumption max. | Model XXX0: 6W Model 2XX5: 12W | Headers and Terminators | Up to four header and four terminator characters |
| Main Serial Interface | RS232; RS485 Full-Duplex/ Half-Duplex; 20 mA C.L. (only with INT-24 accessory) | | |
| Auxiliary Interface | RS232 | | |
| Baudrates | 1200 to 115200 | | |
| Inputs | (optocoupled NPN or PNP) | Operating Modes | On-Line, Automatic, Serial-On-Line, Test |
| External Trigger, IN1, IN2 | | | |
| Voltage max. | 30 Vdc | Configuration Modes | Through menus using WinHost utility Host Mode (commands from one of the serial ports) |
| Current Consumption max. | 25 mA | | |
| Outputs | (optocoupled OE or OC) | Code Selection | Up to six different codes during one reading phase |
| OUT1, OUT2 | | | |
| V_{CE} max. | | 40 Vdc | |
| Collector Current max. | 40 mA continuous; 130 mA pulsed | Parameter Storage | Non-volatile internal EEPROM |
| V_{CE} Saturation | 1V at 10 mA max. | ENVIRONMENTAL FEATURES | |
| Power Dissipation max. | 90 mW at 40 °C (Ambient temp.) | Operating Temperature | 0° to 40 °C (32° to 104 °F) 2XX5: -30° (-22 °F) to 40 °C |
| OPTICAL FEATURES | | Storage Temperature | -20° to 70 °C (-4° to 158 °F) |
| Light Source | Semiconductor laser diode | Humidity max | 90% non condensing |
| Wavelength | 630 to 680 nm | Protection Class | IP65 |
| Safety Class | Class 2 - EN 60825-1; CDRH | USER INTERFACE | |
| PHYSICAL FEATURES | | LED Indicators | Ready, Good Read, External Trigger, Data TX |
| Dimensions | 101x84x42 mm (4x3.3x1.7 in) | | |
| Weight | 615 g. (22 oz) | | |

Accessories:

| Name | Description | Part Number |
|---------------|------------------------------------|----------------------|
| C-BOX 100/200 | Connection Box | 93ACC1510, 93ACC1520 |
| C-BOX 300/310 | Connection Box Profibus | 93A301000, 93A301030 |
| GFC-41 | 90° Reading Device | 91D081000 |
| OM4000 | Oscillating Mirror | 93A251030 |
| INT-24 | 20 mA Current Loop Interface Board | 93A151000 |

Electrical Connections:

DS4600A is equipped with a cable terminated by a 25-pin female D-sub connector for connection to the power supply and input/output signals.



CAUTION

Do not connect GND and SGNDs (Main or Aux) to different (external) ground references. GND and SGNDs (Main and Aux) are internally connected through filtering circuitry which can be permanently damaged if subjected to voltage drops over 0.8 Vdc.

The details of the connector pins are indicated in the following table:

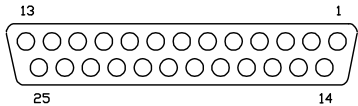
| 25-pin D-sub female connector pinout | | | | | | |
|--------------------------------------|-----------|-----------------------------------|--|--|-------------------|------------------------------|
| Pin | Name | Function | | | | |
| 13 | VS | Power supply input voltage + |  <p style="text-align: center;">25-pin female connector</p> | | | |
| 25 | GND | Power supply input voltage - | | | | |
| 1 | CHASSIS | Chassis Ground | | | | |
| 9 | VS | External Trigger supply voltage + | | | | |
| 18 | EXT TRIG+ | External Trigger + | | | | |
| 19 | EXT TRIG- | External Trigger - | | | | |
| 6 | IN1+ | Input 1 + | | | | |
| 10 | IN1- | Input 1 - | | | | |
| 14 | IN2+ | Input 2 + | | | | |
| 15 | IN2- | Input 2 - | | | | |
| 8 | OUT1 + | Output 1 + | | | | |
| 22 | OUT1- | Output 1 - | | | | |
| 11 | OUT2 + | Output 2 + | | | | |
| 12 | OUT2- | Output 2 - | | | | |
| 20 | RXAUX | Auxiliary RS232 | | | | |
| 21 | TXAUX | Auxiliary RS232 | | | | |
| 23 | SGND Aux | Signal Ground Auxiliary interface | | | | |
| 24 | GND | Power Supply Voltage - | | | | |
| 16 | Reserved | | | | | |
| 17 | Reserved | | | | | |
| Pin | RS232 | RS485 Full-Duplex | | | RS485 Half-Duplex | 20 mA C.L. (INT-24 Only) |
| 2 | TX232 | TX485+ | | | RTX485+ | CLOUT- CLIN- SGND Main |
| 3 | RX232 | RX485+ | | | | |
| 4 | RTS232 | TX485- | | | RTX485- | |
| 5 | CTS232 | RX485- | | | | |
| 7 | SGND Main | SGND Main | SGND Main | | | |

Mechanical Installation:

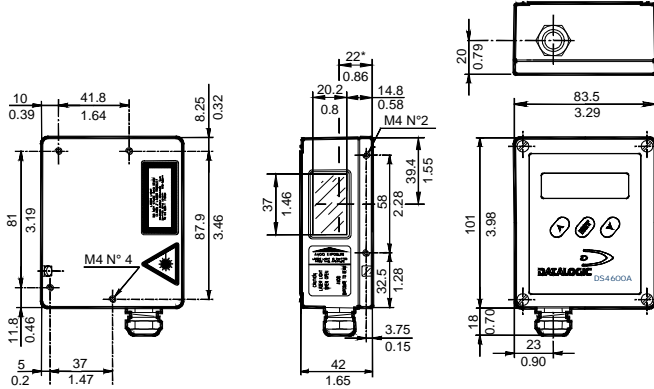

Mounting hole depth M4 X 5 * The quote refers to the scan line

Figure - Overall dimensions for 2XXX Models

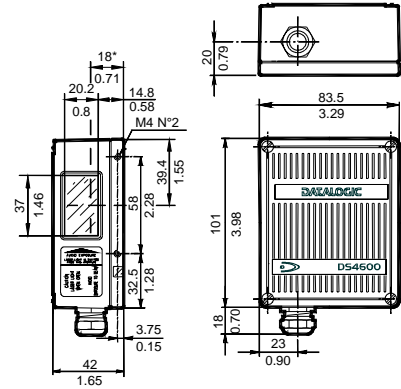

* The quote refers to the scan line

Figure - Overall dimensions for 3XXX Models

Input/Output Connections:

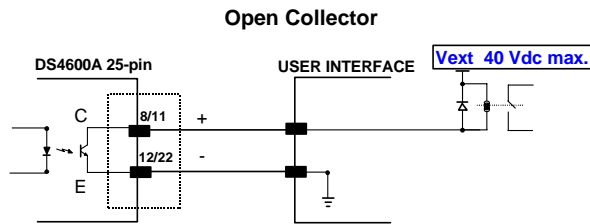

Output open collector connections

$V_{CE} \text{ max} = 40 \text{ Vdc}$

$I \text{ max} = 40 \text{ mA continuous}$

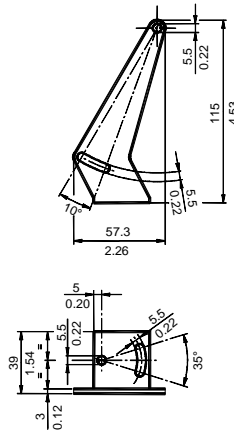

Mounting Bracket Dimensions

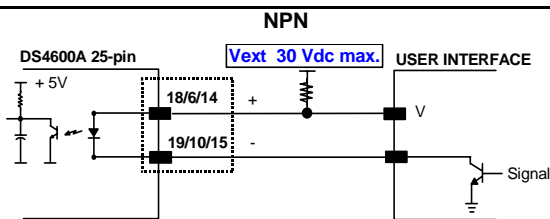

Input NPN command using external power

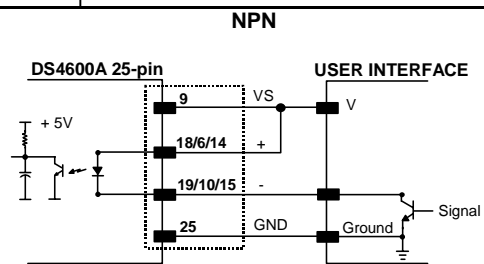

Input NPN command using DS4600A power

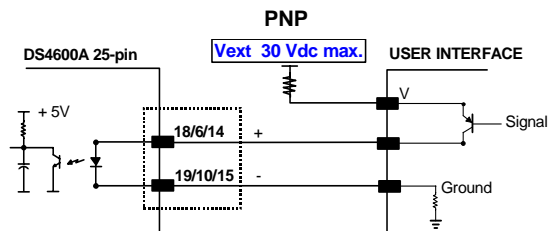

Input PNP command using external power

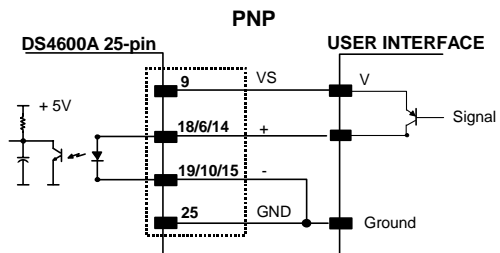

Input PNP command using DS4600A power

Connectivity:

Point-to-point layout

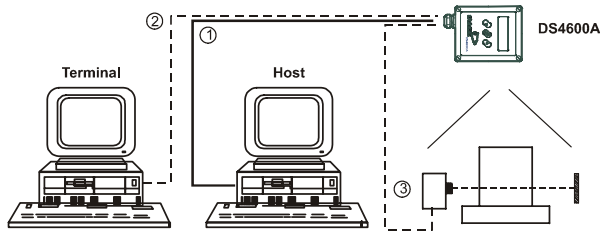

- ① Main Serial Interface
- ② Auxiliary Serial Interface (Local Echo) (RS232)
- ③ External Trigger (for On-Line Mode)

Pass-through layout

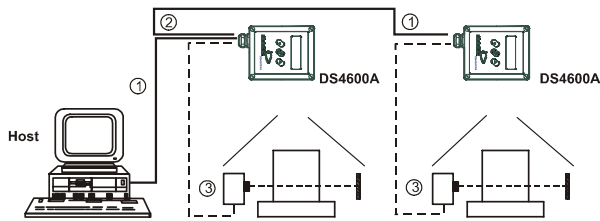

- ① Main Serial Interface (RS232)
- ② Auxiliary Serial Interface (RS232)
- ③ External Trigger (for On-Line Mode)

RS232 Master/slave layout

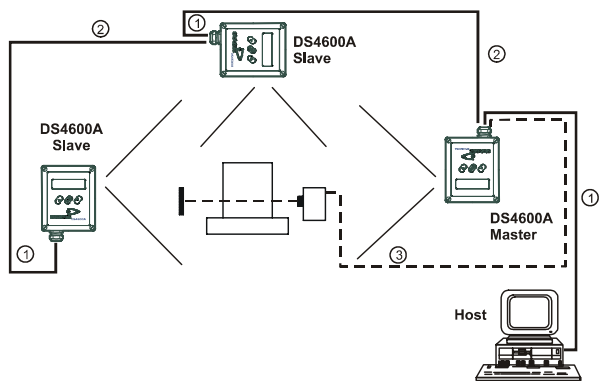

- ① Main Serial Interface (Slaves RS232 only)
- ② Auxiliary Serial Interface (RS232)
- ③ External Trigger (for On-Line Mode)

Multiplexer layout

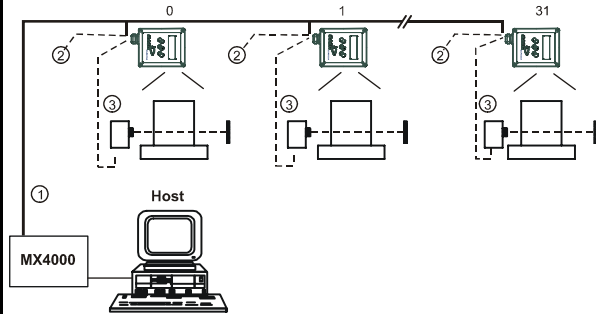

- ① Main Serial Interface (RS485 Half-Duplex)
- ② Auxiliary Serial Interface (Local Echo) (RS232)
- ③ External Trigger (for On-Line Mode)

RS485 Master/slave layout

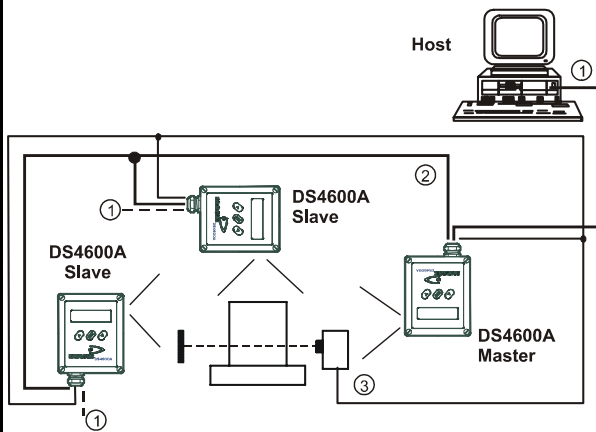

- ① Auxiliary Serial Interface (RS232)
- ② Main Serial Interface (RS485 Half-Duplex)
- ③ External Trigger

Reading Diagrams:

DS4600A-210X (Long Range)

CONDITIONS

Code = Interleaved 2/5 or Code 39
 PCS = 0.90
 Pitch angle = 0°
 Skew angle = 15°
 Tilt angle = 0°

*Code Resolution:
 Standard - for 0.50 mm (20 mils) codes and greater

*Code Reading Condition:
 Standard

* Parameter selectable in WinHost.

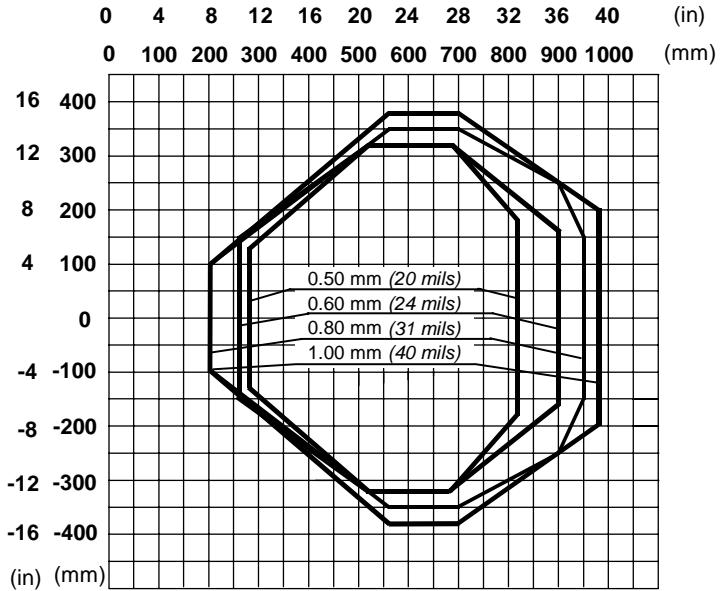

DS4600A-200X (Medium Range)

CONDITIONS

Code = Interleaved 2/5 or Code 39
 PCS = 0.90
 Pitch angle = 0°
 Skew angle = 15°
 Tilt angle = 0°

*Code Resolution:
 High - for 0.30 mm (12 mils) codes and smaller
 Standard - for 0.50 mm (20 mils) codes and greater

*Code Reading Condition:
 Standard

* Parameter selectable in WinHost.

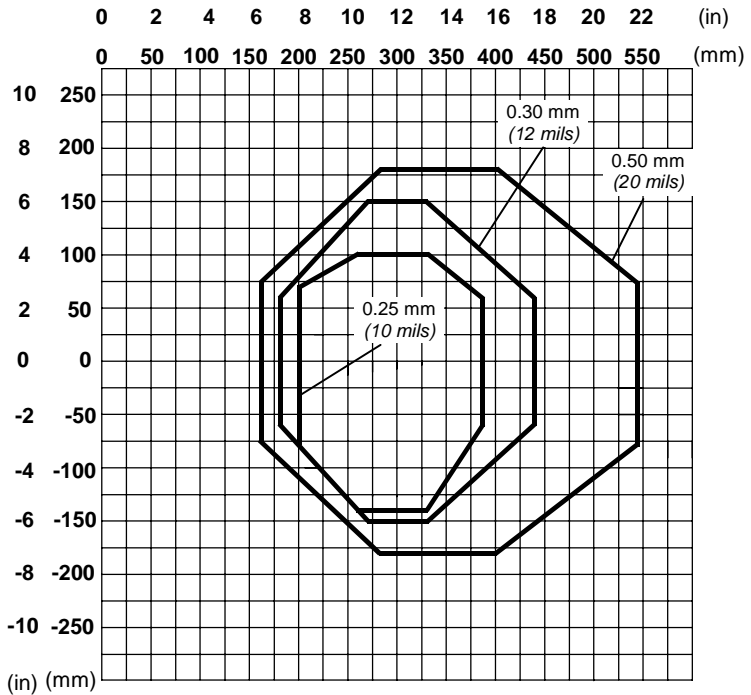

Reading Diagrams:

DS4600A-22XX (Short Range)

CONDITIONS

Code = Interleaved 2/5 or Code 39
 PCS = 0.90
 "Pitch" angle = 0°
 "Skew" angle = 10°
 "Tilt" angle = 0°
 *SW Resolution = High

* Parameter selectable in WinHost

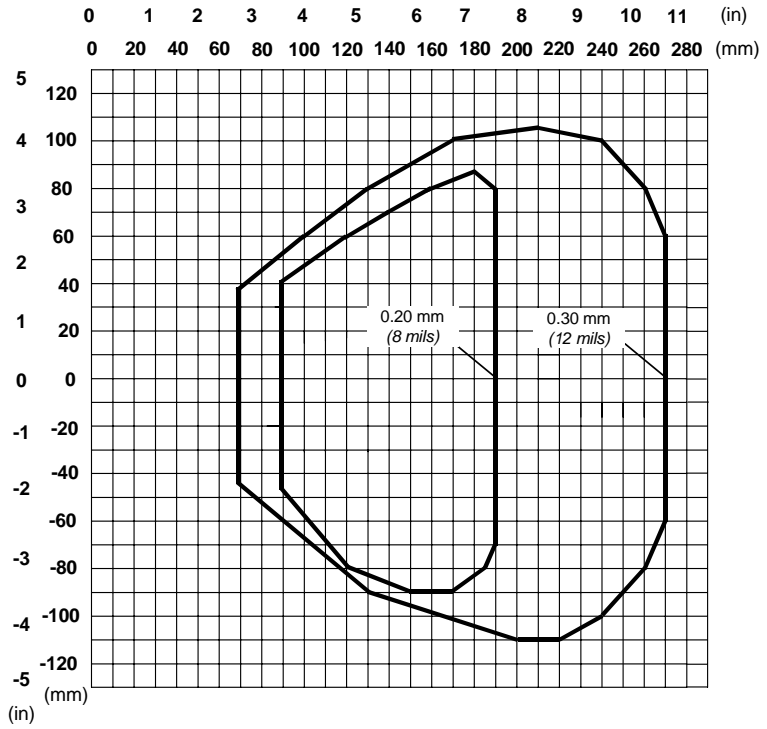

DS4600A-22XX (Short Range)

CONDITIONS

Test Codes used = Interleaved 2/5 and Code 39
 PCS = 0.90
 "Pitch" angle = 0°
 "Skew" angle = 10°
 "Tilt" angle = 0°
 *SW Resolution = Low

* Parameter selectable in WinHost

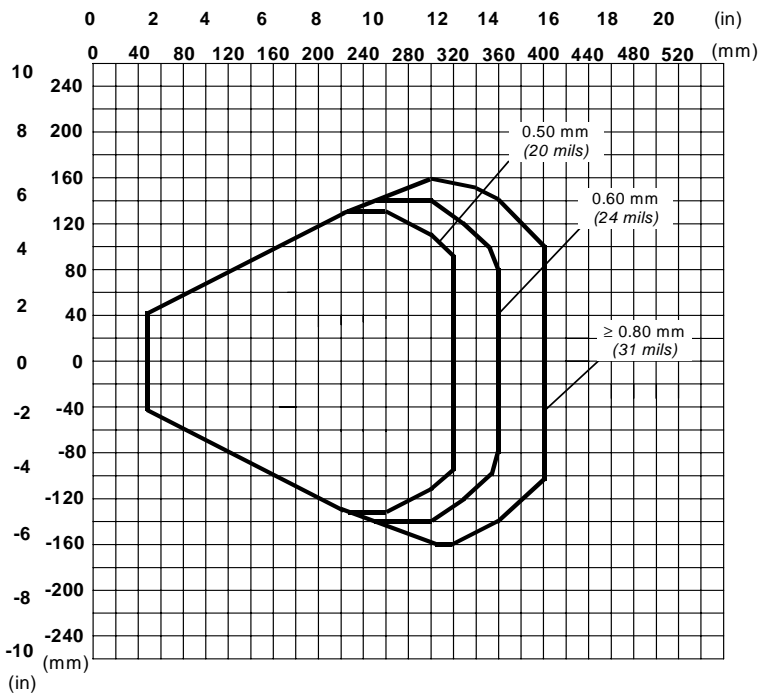

Reading Diagrams:

DS4600A-2X1X (Raster R1)

CONDITIONS

Code = Interleaved 2/5 or Code 39
 PCS = 0.90
 "Pitch" angle = 0°
 "Skew" angle = 18°
 "Tilt" angle = 0°

*Code Resolution:
 High - for 0.30 mm (12 mils) codes and smaller
 Standard - for 0.50 mm (20 mils) codes and greater

*Code Reading Condition:
 Standard

* Parameter selectable in WinHost.

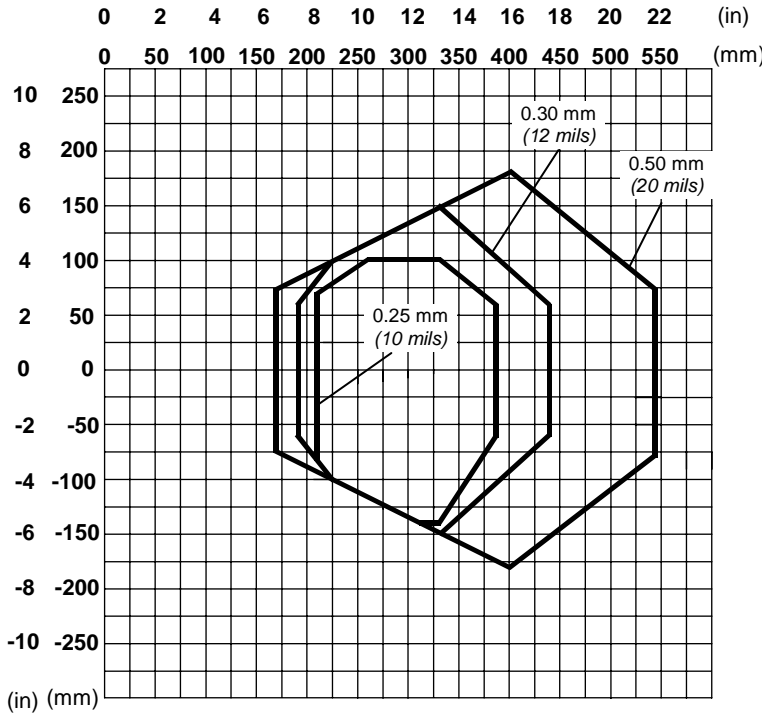

DS4600A-2X2X (Raster R2)

CONDITIONS

Code = Interleaved 2/5 or Code 39
 PCS = 0.90
 Pitch angle = 0°
 Skew angle = 18°
 Tilt angle = 0°

*Code Resolution:
 High - for 0.30 mm (12 mils) codes and smaller
 Standard - for 0.50 mm (20 mils) codes and greater

*Code Reading Condition:
 Standard

* Parameter selectable in WinHost.

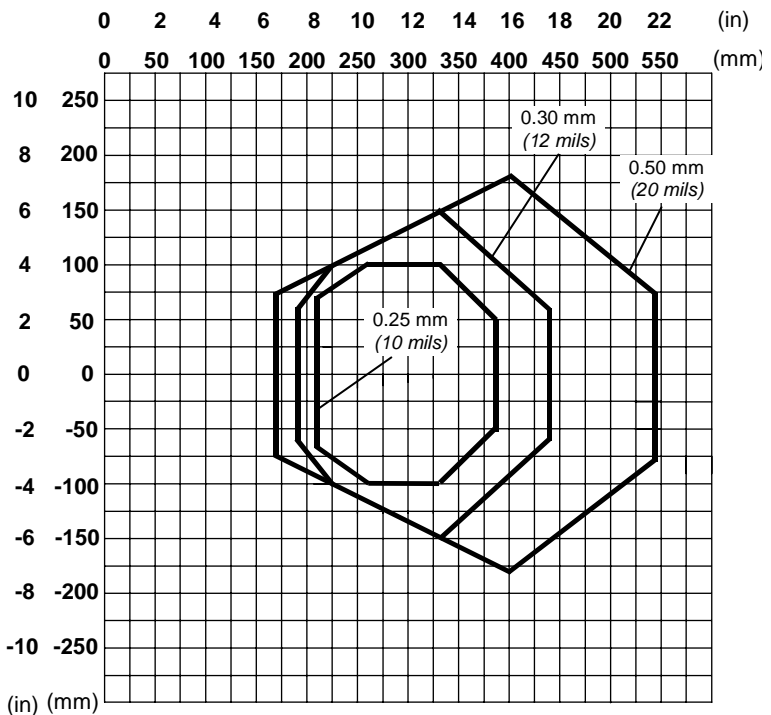

DS4600A-31XX (Long Range)

CONDITIONS

Code = Interleaved 2/5 and Code 39
 "Pitch" angle = 0°
 "Skew" angle = 15°
 "Tilt" angle = 0°
 *Code Resolution = Standard for 0.50 mm (20 mils) codes and greater
 *Code Reading Conditions = Standard
 * Parameter selectable in WinHost

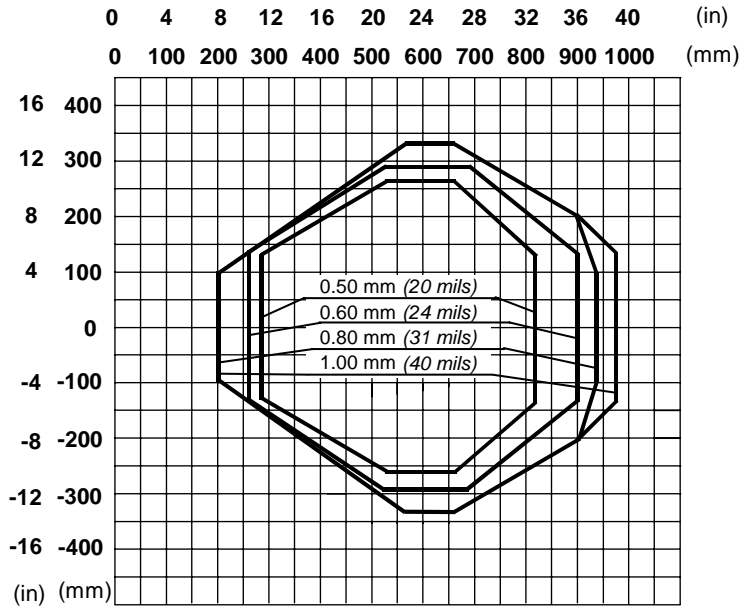

DS4600A-30XX (Medium Range)

CONDITIONS

Code = Interleaved 2/5 and Code 39
 PCS = 0.90
 "Pitch" angle = 0°
 "Skew" angle = 15°
 "Tilt" angle = 0°
 *Code Resolution: High for 0.30 mm (12 mils) codes and smaller
 Standard for 0.50 mm (20 mils) codes and greater
 *Code Reading Conditions: Standard
 * Parameter selectable in WinHost.

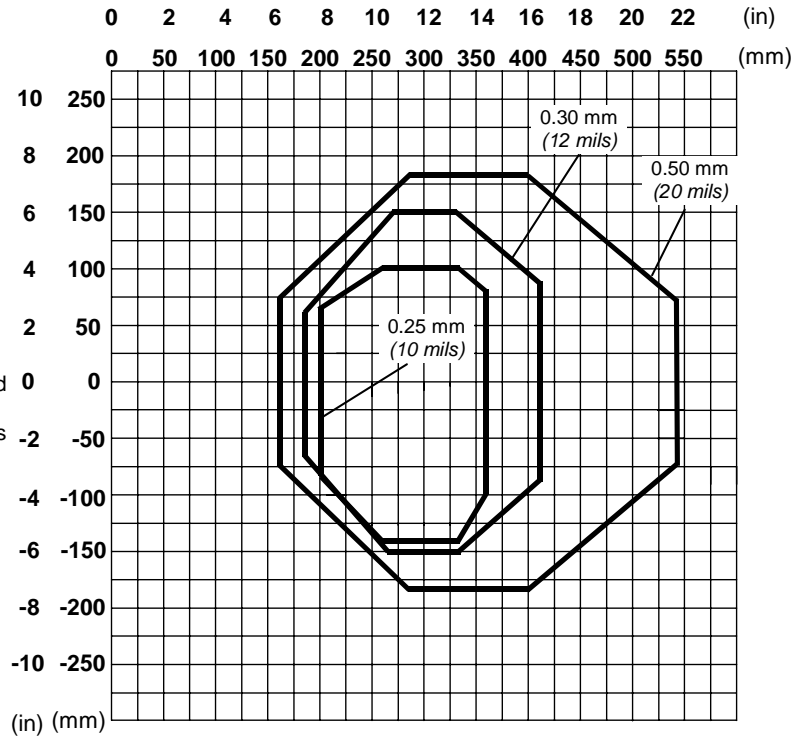

DS4600A-32XX (Short Range)

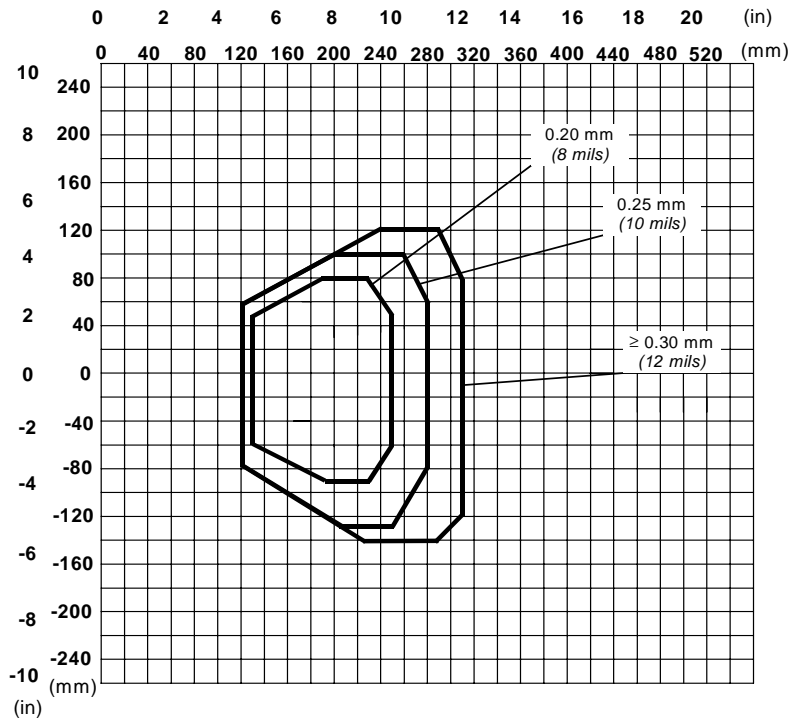

CONDITIONS

Code = Interleaved 2/5 and Code 39
 PCS = 0.90
 "Pitch" angle = 0°
 "Skew" angle = 15°
 "Tilt" angle = 0°
 *SW Resolution: High

* Parameter selectable in WinHost.

User Interface:

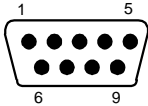
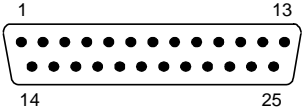
| RS232 PC-side connections | | | |
|---|------|---|------|
|  <p>9-pin male connector</p> | |  <p>25-pin male connector</p> | |
| Pin | Name | Pin | Name |
| 2 | RX | 3 | RX |
| 3 | TX | 2 | TX |
| 5 | GND | 7 | GND |
| 7 | RTS | 4 | RTS |
| 8 | CTS | 5 | CTS |

How To Build A Simple Interface Test Cable:

The following wiring diagram shows a simple test cable including power, external (push-button) trigger and PC RS232 COM port connections.

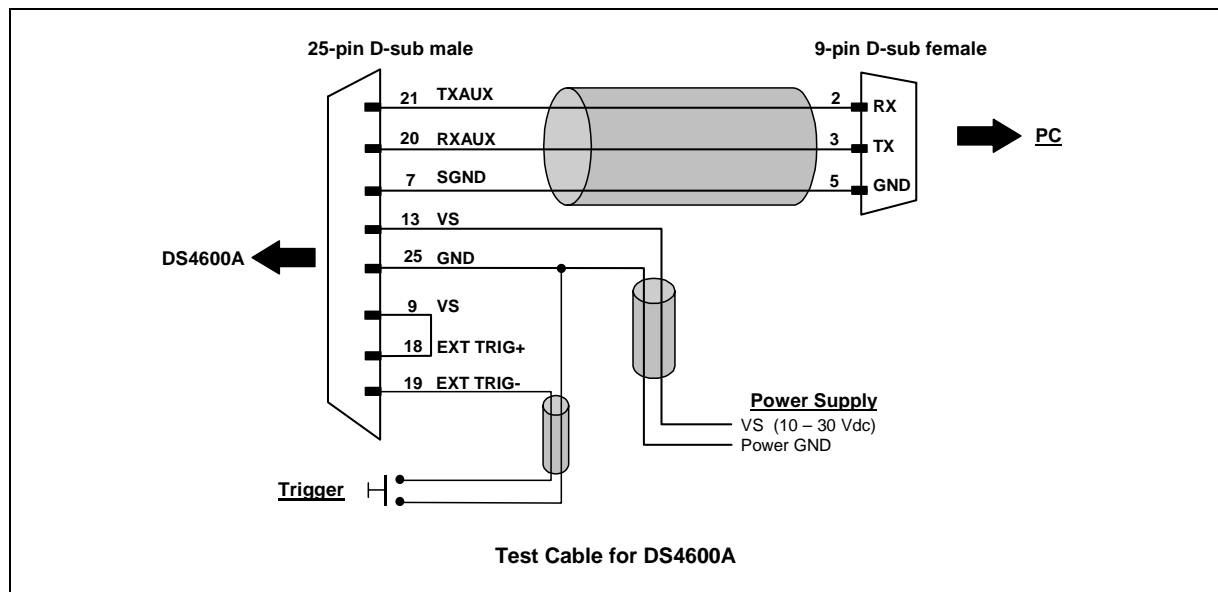



dichiara che
declares that the
déclare que le
bescheinigt, daß das Gerät
declare que el

DS4600A-XXXX Laser Scanner e tutti i suoi modelli
and all its models
et tous ses modèles
und seine modelle
y todos sus modelos

sono conformi alle Direttive del Consiglio Europeo sottoelencate:
are in conformity with the requirements of the European Council Directives listed below:
sont conformes aux spécifications des Directives de l'Union Européenne ci-dessous:
der nachstehend angeführten Direktiven des Europäischen Rats:
cumple con los requisitos de las Directivas del Consejo Europeo, según la lista siguiente:

| | | |
|----------------------------------|-----------------------------|----------------------------|
| 89/336/EEC EMC Directivee | 92/31/EEC, 93/68/EEC | emendamenti successivi |
| and | | further amendments |
| et | | ses successifs amendements |
| und | | späteren Abänderungen |
| y | | sucesivas enmiendas |

Basate sulle legislazioni degli Stati membri in relazione alla compatibilità elettromagnetica ed alla sicurezza dei prodotti.
On the approximation of the laws of Member States relating to electromagnetic compatibility and product safety.
Basée sur la législation des Etates membres relative à la compatibilité électromagnétique et à la sécurité des produits.
Über die Annäherung der Gesetze der Mitgliedsstaaten in bezug auf elektromagnetische Verträglichkeit und Produktsicherheit entsprechen.
Basado en la aproximación de las leyes de los Países Miembros respecto a la compatibilidad electromagnética y las Medidas de seguridad relativas al producto.

Questa dichiarazione è basata sulla conformità dei prodotti alle norme seguenti:
This declaration is based upon compliance of the products to the following standards:
Cette déclaration repose sur la conformité des produits aux normes suivantes:
Diese Erklärung basiert darauf, daß das Produkt den folgenden Normen entspricht:
Esta declaración se basa en el cumplimiento de los productos con las siguientes normas:

EN 55022, August 1994: LIMITS AND METHODS OF MEASUREMENTS OF RADIO DISTURBANCE CHARACTERISTICS OF INFORMATION TECHNOLOGY EQUIPMENT (ITE)

EN 61000-6-2, April 1999: ELECTROMAGNETIC COMPATIBILITY (EMC).
PART 6-2: GENERIC STANDARDS - IMMUNITY FOR INDUSTRIAL ENVIRONMENTS

Lippo di Calderara, 13/09/2002

Ruggero Cacioppo
Quality Assurance Supervisor