

# VFS60: Motor Feedback System for installation on asynchronous motors

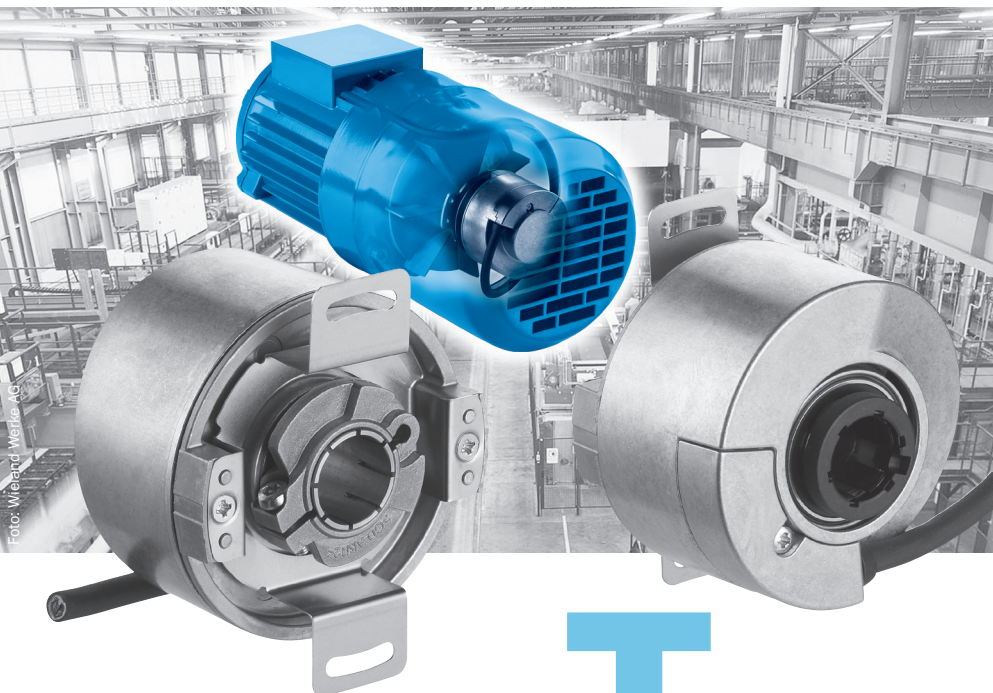

Select the motor feedback system to suit your individual requirements. Possible product variations:

- Through hollow or blind hollow shaft
- Cable outlet universal 0.5 m or 1.5 m
- Number of lines from 1 up to 65.536
- Interfaces TTL or HTL and versions with programmable level of output signals
- Zero pulse width programmable by customer



The VFS60 is a high-resolution incremental hollow shaft encoder in a 60 mm housing.

An Electrically insulating hollow shaft clamping arrangement is available for special applications, significantly increasing the interference immunity.

Excellent concentricity and exceptional robustness are achieved thanks to the large distance between the ball bearings which support the encoder shaft

VFS60 series encoders have been designed for arduous applications in harsh industrial environments, and especially for mounting to asynchronous motors.

	<b>Number of lines up to 65.536</b>
<b>Motor Feedback System</b>	



## SICK | STEGMANN

**Number of lines up to 65.536**

**Motor Feedback System**

- Cable outlet
- Protection class IP 65
- Electrical interfaces TTL, HTL

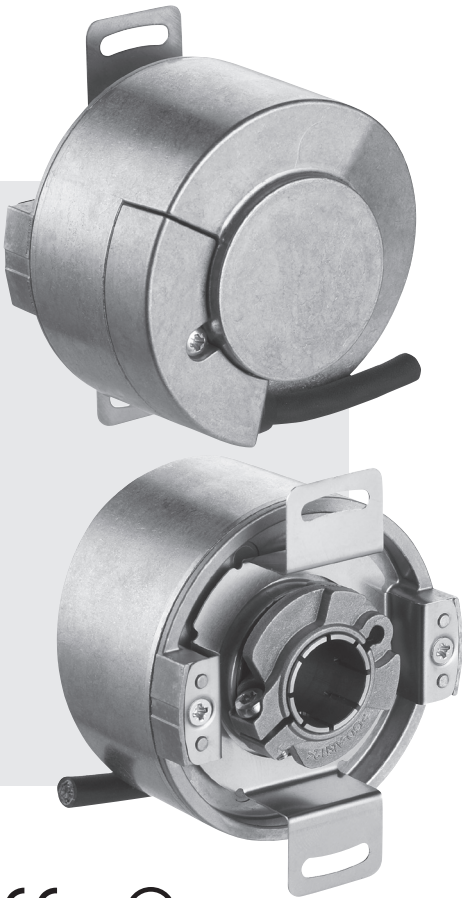

## Dimensional drawing blind hollow shaft, cable outlet

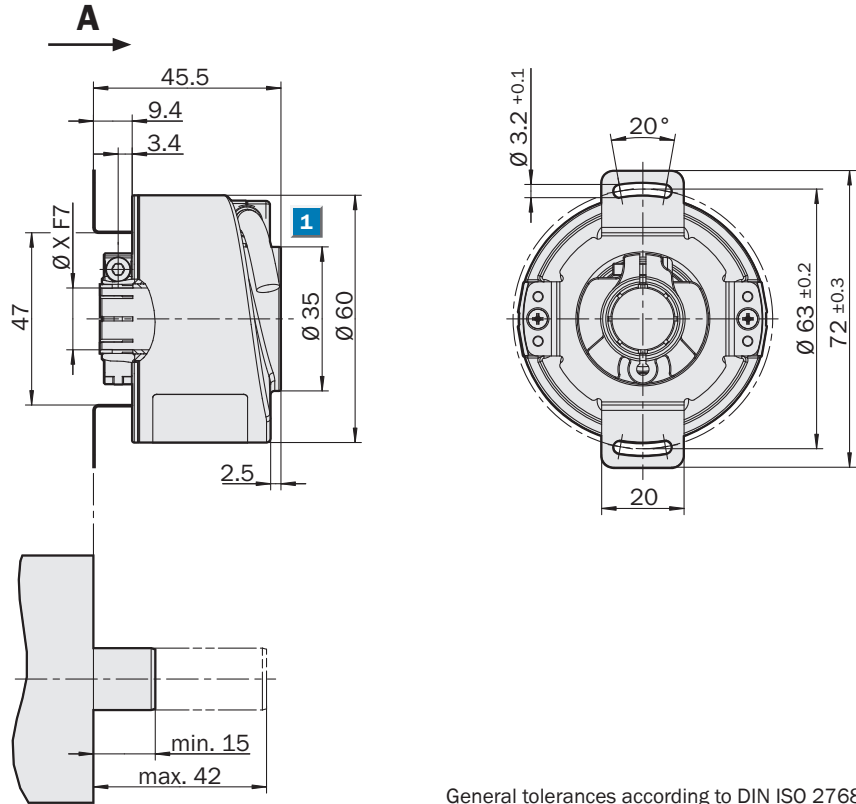

General tolerances according to DIN ISO 2768-mk

Customer-side

- 1** Cable- $\varnothing = 5.6 \pm 0.2$  mm  
Bending radius  $R = 30$  mm

## Wire allocation, cable 8-core

Colour of wires	Signal TTL, HTL	Explanation
Brown	$\bar{A}$	Signal line
White	A	Signal line
Black	$\bar{B}$	Signal line
Pink	B	Signal line
Yellow	$\bar{Z}$	Signal line
Lilac	Z	Signal line
Blue	GND	Ground connection of the encoder
Red	+U <sub>s</sub>	Supply voltage <sup>1)</sup>
Screen	Screen	Screen <sup>2)</sup>

<sup>1)</sup> Potential free to housing

<sup>2)</sup> Screen on the encoder side connected to the housing. On the control side connected to earth.

## Accessories

Connection systems (page 16/17)

Mounting systems (page 16/17)

Technical Data to DIN 32878		VFS60 blind hollow shaft		
Type		E	B	A
Shaft diameter	8, 10, 12, 14, 15 mm a. 3/8", 1/2", 5/8"			
Electrical interface	4.5 ... 5.5 V, TTL/RS422			
	10 ... 32 V, TTL/RS422			
	10 ... 32 V, HTL/push-pull			
	4,5 ... 32 V, TTL/HTL programmable			
Number of lines per revolution		1000, 1024, 2000, 2048	1000, 1024, 2000, 2048, 4096, 8192 16384, 32768, 65536	1 ... 8192 16384, 32768 65536
Mass	0.2 kg			
Moment of inertia to the rotor	40 gcm <sup>2</sup>			
Measuring step	90° electric/number of lines			
Reference signal	Number 1			
	Position 90° electr., gated with A and B			
Error limits		± 0.3°	± 0.05°	± 0.03°
Measuring step deviation		± 0.2°	± 0.01°	± 0.01°
Max. output frequency	TTL/RS422	300 kHz	600 kHz	820 kHz
	HTL/push-pull	300 kHz	600 kHz	820 kHz
	TTL/HTL programmable			820 kHz
Operating speed <sup>1)</sup>		6,000 min <sup>-1</sup>	6,000 min <sup>-1</sup>	6,000 min <sup>-1</sup>
Angular acceleration	5 x 10 <sup>5</sup> rad/s <sup>2</sup>			
Operating torque at 20 °C	0.6 Ncm			
Starting torque at 20 °C	0.8 Ncm			
<b>Permissible shaft loading</b>				
radial	Static/dynamic	± 0.3/± 0.1 mm	± 0.3/± 0.1 mm	± 0.3/± 0.05 mm
axial	Static/dynamic	± 0.5/± 0.2 mm	± 0.5/± 0.2 mm	± 0.5/± 0.01 mm
Bearing lifetime	3 x 10 <sup>9</sup> revolutions			
Working temperature range		-20 ... + 100 °C	-20 ... + 100 °C	-20 ... + 100 °C
Storage temperature range (without package)		-40 ... + 100 °C	-40 ... + 100 °C	-40 ... + 100 °C
Permissible relative humidity <sup>2)</sup>	90 %			
<b>EMC <sup>3)</sup></b>				
Resistance	To shocks <sup>4)</sup>	50 g/6 ms	70 g/6 ms	60 g/6 ms
	To vibration <sup>5)</sup>	20 g/10 ... 2000 Hz	30 g/10 ... 2000 Hz	20 g/10 ... 2000 Hz
<b>Protection class to IEC 60529</b>				
Shaft side		IP 65	IP 65	IP 65
Housing side	Cable outlet	IP 67	IP 67	IP 67
Load current	4.5 ... 5.5 V, TTL/RS422	max. 30 mA	max. 30 mA	max. 30 mA
	10 ... 32 V, TTL/RS422	max. 30 mA	max. 30 mA	max. 30 mA
	10 ... 32 V, HTL/push-pull	max. 30 mA	max. 30 mA	max. 30 mA
	4,5 ... 32 V, TTL/HTL programmable			max. 30 mA
No-load operating current	4.5 ... 5.5 V, TTL/RS422	40 mA	40 mA	40 mA
	10 ... 32 V, TTL/RS422	40 mA	40 mA	40 mA
	10 ... 32 V, HTL/push-pull	40 mA	40 mA	40 mA
	4,5 ... 32 V, TTL/HTL programmable			60 mA
Initialisation time after power on	4.5 ... 5.5 V, TTL/RS422	40 ms	40 ms	40 ms
	10 ... 32 V, TTL/RS422	40 ms	40 ms	40 ms
	10 ... 32 V, HTL/HTL programmable	40 ms	40 ms	40 ms
	4,5 ... 32 V, TTL/HTL programmable			max. 30 ms

<sup>1)</sup> Self-warming 3.3k/1,000 min<sup>-1</sup>  
when applying, note working temperature range

<sup>4)</sup> To EN 60068-2-27

<sup>5)</sup> To EN 60068-2-6

<sup>2)</sup> Condensation of the optical scanning not permitted

<sup>3)</sup> To EN 61000-6-2 and EN 61000-6-4

## Order information TTL and HTL interface

## Motor Feedback System VFS60, blind hollow shaft

Point 1	Point 2	Point 3	Point 4	Point 5	Point 6	Point 7	Point 8	Point 9	Point 10	Point 11	Point 12	Point 13	Point 14	Point 15	Point 16
<b>V</b>	<b>F</b>	<b>S</b>	<b>6</b>	<b>0</b>		<b>-</b>	<b>B</b>								

Type (cp. technical data page 3)	Mechanical interface	Electrical interface	Connection type	No. of lines
E	Blind hollow shaft 8 mm = <b>B</b>	4.5 ... 5.5 V, TTL/RS422 = <b>A</b>	Cable 8-core, universal 0.5 m <sup>1)</sup> = <b>J</b>	Always 5 characters in clear text
B	Blind hollow shaft 3/8" = <b>C</b>	10 ... 32 V, TTL/RS422 = <b>C</b>	Cable 8-core, universal 1.5 m <sup>1)</sup> = <b>K</b>	
	Blind hollow shaft 10 mm = <b>D</b>	10 ... 32 V, HTL/Push pull = <b>E</b>		
	Blind hollow shaft 12 mm = <b>E</b>			
	Blind hollow shaft 1/2" = <b>F</b>			
	Blind hollow shaft 14 mm = <b>G</b>			
	Blind hollow shaft 15 mm = <b>H</b>			
	Blind hollow shaft 5/8" = <b>J</b>			

<sup>1)</sup> The universal cable outlet is positioned in such a way, that it is possible to lay the cable in a radial or axial direction without kinking it.

Selection depending on the type, see below.

## Type E – Number of lines per revolution

01000	01024	02000	02048	Others on request
-------	-------	-------	-------	-------------------

## Type B – Number of lines per revolution

01000	02000	04096	16384	65536	Others on request
01024	02048	08192	32768		

## Order example Motor Feedback System VFS60, type E, blind hollow shaft 10 mm,

### Electrical interface 10 ... 32 V, HTL/push-pull, cable 8-core, universal 0.5 m, number of lines 1024

Point 1	Point 2	Point 3	Point 4	Point 5	Point 6	Point 7	Point 8	Point 9	Point 10	Point 11	Point 12	Point 13	Point 14	Point 15	Point 16
<b>V</b>	<b>F</b>	<b>S</b>	<b>6</b>	<b>0</b>	<b>E</b>	<b>-</b>	<b>B</b>	<b>D</b>	<b>E</b>	<b>J</b>	<b>0</b>	<b>1</b>	<b>0</b>	<b>2</b>	<b>4</b>

**Order information TTL or HTL programmable**

**Motor Feedback System VFS60, blind hollow shaft**

Point 1	Point 2	Point 3	Point 4	Point 5	Point 6	Point 7	Point 8	Point 9	Point 10	Point 11	Point 12	Point 13	Point 14	Point 15	Point 16
V	F	S	6	0		-	B								

<b>Type</b> (cp. technical data page 3) A	<b>Mechanical interface</b> Blind hollow shaft 8 mm = <b>B</b> Blind hollow shaft 3/8" = <b>C</b> Blind hollow shaft 10 mm = <b>D</b> Blind hollow shaft 12 mm = <b>E</b> Blind hollow shaft 1/2" = <b>F</b> Blind hollow shaft 14 mm = <b>G</b> Blind hollow shaft 15 mm = <b>H</b> Blind hollow shaft 5/8" = <b>J</b>	<b>Electrical interface</b> 4,5 ... 32 V, TTL/HTL programmable = <b>P</b>	<b>Connection type</b> Cable 8-core, universal 0.5 m <sup>1)</sup> = <b>J</b> Cable 8-core, universal 1.5 m <sup>1)</sup> = <b>K</b>	<b>No. of lines</b> Factory-programmed to 1024
--	---	--	--	---

<sup>1)</sup> The universal cable outlet is positioned in such a way, that it is possible to lay the cable in a radial or axial direction without kinking it.

**Order example Motor Feedback System VFS60, type A, blind hollow shaft 8 mm, programmable number of lines from 1 ... 8192,**

**Electrical interface 5 ... 32 V, cable 8-core, universal 0.5 m**

Point 1	Point 2	Point 3	Point 4	Point 5	Point 6	Point 7	Point 8	Point 9	Point 10	Point 11	Point 12	Point 13	Point 14	Point 15	Point 16
V	F	S	6	0	A	-	B	B	P	J	0	1	0	2	4

Factory-programmed number of lines: 1024, level of output signal: TTL

**Programming Tool for VFS60**

<b>Type</b>	<b>Part no.</b>	<b>Contacts</b>
PGT-08-S	1036616	12



**Adapter cable PGT-08-S incremental with Cable connector SUB-D 9-pin male and cable connector M12 8-pin female, ready-made with cable 8-core, 4 x 2 x 0,08 mm<sup>2</sup>, with screening**

<b>Type</b>	<b>Part no.</b>
DSL-2D08-G0M5AC3	2046579

**Adapter cable PGT-08-S incremental with Cable connector SUB-D 9-pin male and cable connector M23 12-pin female, ready-made with cable 8-core, 4 x 2 x 0,08 mm<sup>2</sup>, with screening**

<b>Type</b>	<b>Part no.</b>
DSL-3D08-G0M5AC3	2046580

**Number of lines up to 65.536**

**Motor Feedback System**

- Cable outlet
- Protection class IP 65
- Electrical interfaces TTL, HTL

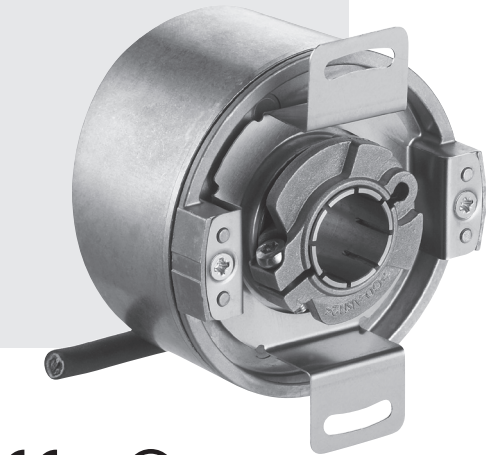
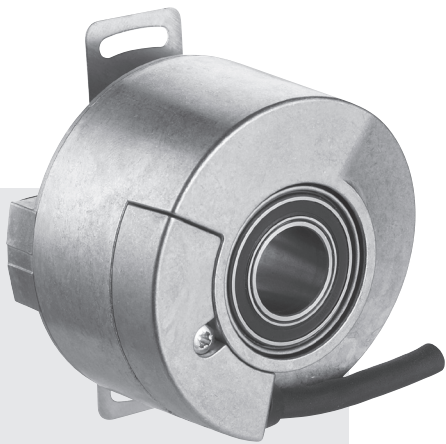

## Dimensional drawing through hollow shaft metal, cable outlet

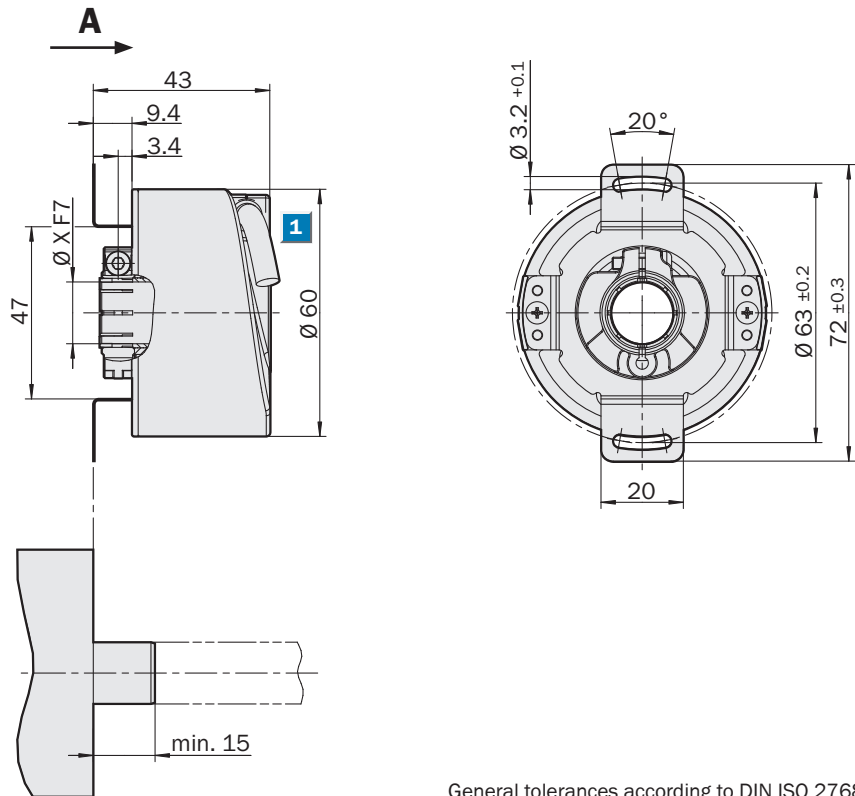

General tolerances according to DIN ISO 2768-mk

Customer-side

- 1** Cable-Ø = 5.6 ± 0.2 mm  
Bending radius R = 30 mm

## Wire allocation, cable 8-core

Colour of wires	Signal TTL, HTL	Explanation
Brown	$\bar{A}$	Signal line
White	A	Signal line
Black	$\bar{B}$	Signal line
Pink	B	Signal line
Yellow	$\bar{Z}$	Signal line
Lilac	Z	Signal line
Blue	GND	Ground connection of the encoder
Red	+U <sub>s</sub>	Supply voltage <sup>1)</sup>
Screen	Screen	Screen <sup>2)</sup>

<sup>1)</sup> Potential free to housing

<sup>2)</sup> Screen on the encoder side connected to the housing. On the control side connected to earth.

## Accessories

Connection systems (page 16/17)

Mounting systems (page 16/17)

Technical Data to DIN 32878		VFS60 through hollow shaft metal		
Type		E	B	A
Shaft diameter	8, 10, 12, 14, 15 mm a. 3/8", 1/2", 5/8"			
Electrical interface	4.5 ... 5.5 V, TTL/RS422			
	10 ... 32 V, TTL/RS422			
	10 ... 32 V, HTL/push-pull			
	4,5 ... 32 V, TTL/HTL programmable			
Number of lines per revolution		1000, 1024,	1000, 1024, 2000,	1 ... 8192
		2000, 2048	2048, 4096, 8192	16384, 32768
			16384, 32768, 65536	65536
Mass	0.2 kg			
Moment of inertia to the rotor	40 gcm <sup>2</sup>			
Measuring step	90° electric/number of lines			
Reference signal	Number	1		
	Position	90° electr., gated with A and B		
Error limits		± 0.3°	± 0.05°	± 0.03°
Measuring step deviation		± 0.2°	± 0.01°	± 0.01°
Max. output frequency	TTL/RS422	300 kHz	600 kHz	820 kHz
	HTL/push-pull	300 kHz	600 kHz	820 kHz
	TTL/HTL programmable			820 kHz
Operating speed <sup>1)</sup>		9,000 min <sup>-1</sup>	9,000 min <sup>-1</sup>	9,000 min <sup>-1</sup>
Angular acceleration	5 x 10 <sup>5</sup> rad/s <sup>2</sup>			
Operating torque at 20 °C	0.6 Ncm			
Starting torque at 20 °C	0.8 Ncm			
<b>Permissible shaft loading</b>				
radial	Static/dynamic	± 0.3/± 0.1 mm	± 0.3/± 0.1 mm	± 0.3/± 0.05 mm
axial	Static/dynamic	± 0.5/± 0.2 mm	± 0.5/± 0.2 mm	± 0.5/± 0.01 mm
Bearing lifetime	3 x 10 <sup>9</sup> revolutions			
Working temperature range		-20 ... + 100 °C	-20 ... + 100 °C	-20 ... + 100 °C
Storage temperature range (without package)		-40 ... + 100 °C	-40 ... + 100 °C	-40 ... + 100 °C
Permissible relative humidity <sup>2)</sup>	90 %			
<b>EMC <sup>3)</sup></b>				
Resistance	To shocks <sup>4)</sup>	50 g/6 ms	70 g/6 ms	60 g/6 ms
	To vibration <sup>5)</sup>	20 g/10 ... 2000 Hz	30 g/10 ... 2000 Hz	20 g/10 ... 2000 Hz
<b>Protection class to IEC 60529</b>				
Shaft side		IP 65	IP 65	IP 65
Housing side	Cable outlet	IP 67	IP 67	IP 67
Load current	4.5 ... 5.5 V, TTL/RS422	max. 30 mA	max. 30 mA	max. 30 mA
	10 ... 32 V, TTL/RS422	max. 30 mA	max. 30 mA	max. 30 mA
	10 ... 32 V, HTL/push-pull	max. 30 mA	max. 30 mA	max. 30 mA
	4,5 ... 32 V, TTL/HTL programmable			max. 30 mA
No-load operating current	4.5 ... 5.5 V, TTL/RS422	40 mA	40 mA	40 mA
	10 ... 32 V, TTL/RS422	40 mA	40 mA	40 mA
	10 ... 32 V, HTL/push-pull	40 mA	40 mA	40 mA
	4,5 ... 32 V, TTL/HTL programmable			60 mA
Initialisation time after power on	4.5 ... 5.5 V, TTL/RS422	40 ms	40 ms	40 ms
	10 ... 32 V, TTL/RS422	40 ms	40 ms	40 ms
	10 ... 32 V, HTL/ Push pull	40 ms	40 ms	40 ms
	4,5 ... 32 V, TTL/HTL programmable			max. 30 ms

<sup>1)</sup> Self-warming 3.3k/1,000 min<sup>-1</sup>  
when applying, note working temperature range

<sup>4)</sup> To EN 60068-2-27

<sup>5)</sup> To EN 60068-2-6

<sup>2)</sup> Condensation of the optical scanning not permitted

<sup>3)</sup> To EN 61000-6-2 and EN 61000-6-4

## Order information TTL and HTL interface

## Motor Feedback System VFS60, through hollow shaft metal

Point 1	Point 2	Point 3	Point 4	Point 5	Point 6	Point 7	Point 8	Point 9	Point 10	Point 11	Point 12	Point 13	Point 14	Point 15	Point 16
<b>V</b>	<b>F</b>	<b>S</b>	<b>6</b>	<b>0</b>		<b>-</b>	<b>T</b>								

Type (cp. technical data page 7)	Mechanical interface Through hollow shaft	Electrical interface	Connection type	No. of lines
E	Metal 8 mm = <b>B</b>	4.5 ... 5.5 V, TTL/RS422 = <b>A</b>	Cable 8-core, universal 0.5 m <sup>1)</sup> = <b>J</b>	Always 5 characters in clear text
B	Metal 3/8" = <b>C</b> Metal 10 mm = <b>D</b> Metal 12 mm = <b>E</b> Metal 1/2" = <b>F</b> Metal 14 mm = <b>G</b> Metal 15 mm = <b>H</b> Metal 5/8" = <b>J</b>	10 ... 32 V, TTL/RS422 = <b>C</b> 10 ... 32 V, HTL/push-pull = <b>E</b>	Cable 8-core, universal 1.5 m <sup>1)</sup> = <b>K</b>	

<sup>1)</sup> The universal cable outlet is positioned in such a way, that it is possible to lay the cable in a radial or axial direction without kinking it.

Selection depending on the type, see below.

### Type E - Number of lines per revolution

01000	01024	02000	02048	Others on request
-------	-------	-------	-------	-------------------

### Type B - Number of lines per revolution

01000	02000	04096	16384	65536	Others on request
01024	02048	08192	32768		

### Order example Motor Feedback System VFS60, type E, through hollow shaft 10 mm,

#### Electrical interface 10 ... 32 V, HTL/push-pull, cable 8-core, universal 0.5 m, number of lines 1024

Point 1	Point 2	Point 3	Point 4	Point 5	Point 6	Point 7	Point 8	Point 9	Point 10	Point 11	Point 12	Point 13	Point 14	Point 15	Point 16
<b>V</b>	<b>F</b>	<b>S</b>	<b>6</b>	<b>0</b>	<b>E</b>	<b>-</b>	<b>T</b>	<b>D</b>	<b>E</b>	<b>J</b>	<b>0</b>	<b>1</b>	<b>0</b>	<b>2</b>	<b>4</b>



**Order information TTL or HTL programmable**

**Motor Feedback System VFS60, through hollow shaft metal**

Point 1	Point 2	Point 3	Point 4	Point 5	Point 6	Point 7	Point 8	Point 9	Point 10	Point 11	Point 12	Point 13	Point 14	Point 15	Point 16
V	F	S	6	0		-	T								

<b>Type</b> (cp. technical data page 7)	<b>Mechanical interface</b>	<b>Electrical interface</b>	<b>Connection type</b>	<b>No. of lines</b>
A	<b>Through hollow shaft</b>	4,5 ... 32 V, TTL/HTL programmable = P	Cable 8-core, universal 0.5 m <sup>1)</sup> = J Cable 8-core, universal 1.5 m <sup>1)</sup> = K	Factory-programmed to 1024
	Metal 8 mm = B Metal 3/8" = C Metal 10 mm = D Metal 12 mm = E Metal 1/2" = F Metal 14 mm = G Metal 15 mm = H Metal 5/8" = J			

<sup>1)</sup> The universal cable outlet is positioned in such a way, that it is possible to lay the cable in a radial or axial direction without kinking it.

**Order example Motor Feedback System VFS60, type A, through hollow shaft 8 mm, programmable number of lines from 1 ... 8192,**

**Electrical interface 5 ... 32 V, cable 8-core, universal 0.5 m**

Point 1	Point 2	Point 3	Point 4	Point 5	Point 6	Point 7	Point 8	Point 9	Point 10	Point 11	Point 12	Point 13	Point 14	Point 15	Point 16
V	F	S	6	0	A	-	T	B	P	J	0	1	0	2	4

Factory-programmed number of lines: 1024, level of output signal: TTL

**Programming Tool for VFS60**

<b>Type</b>	<b>Part no.</b>	<b>Contacts</b>
PGT-08-S	1036616	12



**Adapter cable PGT-08-S incremental with Cable connector SUB-D 9-pin male and cable connector M12 8-pin female, ready-made with cable 8-core, 4 x 2 x 0,08 mm<sup>2</sup>, with screening**

<b>Type</b>	<b>Part no.</b>
DSL-2D08-G0M5AC3	2046579

**Adapter cable PGT-08-S incremental with Cable connector SUB-D 9-pin male and cable connector M23 12-pin female, ready-made with cable 8-core, 4 x 2 x 0,08 mm<sup>2</sup>, with screening**

<b>Type</b>	<b>Part no.</b>
DSL-3D08-G0M5AC3	2046580

**Number of lines  
up to 65.536**

**Motor Feedback System**

- Insulating hollow shaft clamping
- Cable outlet
- Protection class IP 65
- Electrical interfaces TTL, HTL

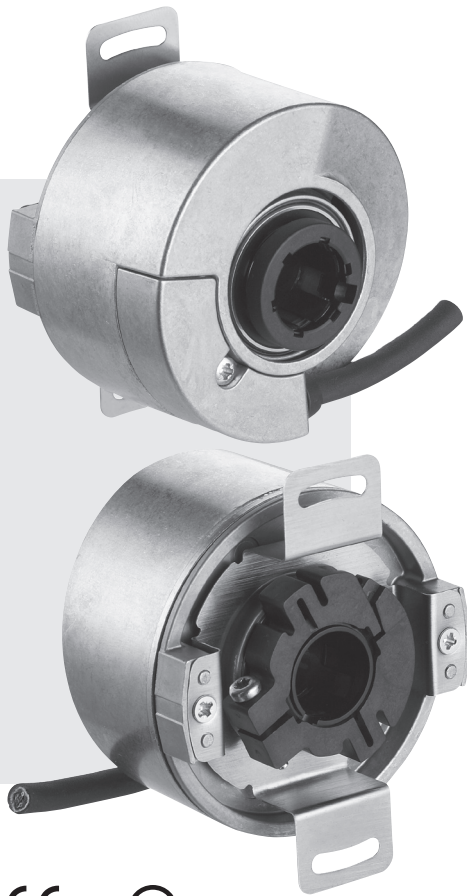

**Dimensional drawing through hollow shaft plastic, cable outlet**

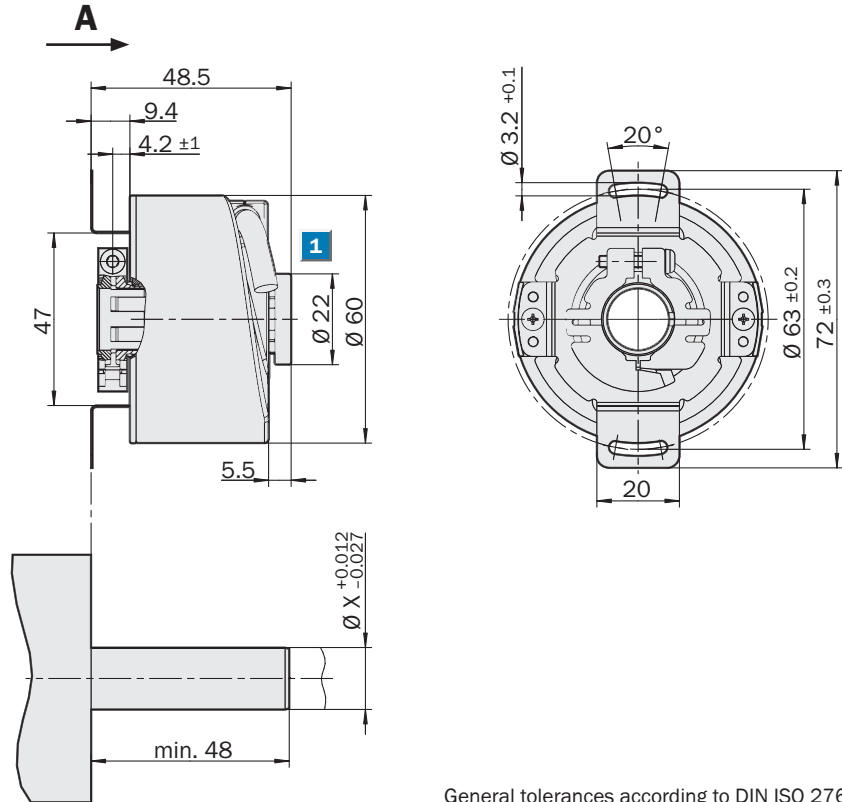

General tolerances according to DIN ISO 2768-mk

Customer-side

- 1** Cable-Ø = 5.6 ± 0.2 mm  
Bending radius R = 30 mm

**Wire allocation, cable 8-core**

Colour of wires	Signal TTL, HTL	Explanation
Brown	$\bar{A}$	Signal line
White	A	Signal line
Black	$\bar{B}$	Signal line
Pink	B	Signal line
Yellow	$\bar{Z}$	Signal line
Lilac	Z	Signal line
Blue	GND	Ground connection of the encoder
Red	+U <sub>s</sub>	Supply voltage <sup>1)</sup>
Screen	Screen	Screen <sup>2)</sup>

<sup>1)</sup> Potential free to housing

<sup>2)</sup> Screen on the encoder side connected to the housing. On the control side connected to earth.

**Accessories**

Connection systems (page 16/17)

Mounting systems (page 16/17)

Technical Data to DIN 32878		VFS60 through hollow shaft plastic		
Type		E	B	A
Shaft diameter	10, 12, 14, 15 mm and 3/8", 1/2"			
Electrical interface	4.5 ... 5.5 V, TTL/RS422			
	10 ... 32 V, TTL/RS422			
	10 ... 32 V, HTL/push-pull			
	4,5 ... 32 V, TTL/HTL programmable			
Number of lines per revolution		1000, 1024,	1000, 1024, 2000,	1 ... 8192
		2000, 2048	2048, 4096, 8192	16384, 32768
			16384, 32768, 65536	65536
Mass	0.2 kg			
Moment of inertia to the rotor	40 gcm <sup>2</sup>			
Measuring step	90° electric/number of lines			
Reference signal	Number	1		
	Position	90° electr., gated with A and B		
Error limits		± 0.3°	± 0.05°	± 0.03°
Measuring step deviation		± 0.2°	± 0.01°	± 0.01°
Max. output frequency	TTL/RS422	300 kHz	600 kHz	820 kHz
	HTL/push-pull	300 kHz	600 kHz	820 kHz
	TTL/HTL programmable			820 kHz
Operating speed <sup>1)</sup>		9,000 min <sup>-1</sup>	12,000 min <sup>-1</sup>	12,000 min <sup>-1</sup>
Angular acceleration	5 x 10 <sup>5</sup> rad/s <sup>2</sup>			
Operating torque at 20 °C	0.6 Ncm			
Starting torque at 20 °C	0.8 Ncm			
<b>Permissible shaft loading</b>				
radial	Static/dynamic	± 0.3/± 0.1 mm	± 0.3/± 0.1 mm	± 0.3/± 0.05 mm
axial	Static/dynamic	± 0.5/± 0.2 mm	± 0.5/± 0.2 mm	± 0.5/± 0.01 mm
Bearing lifetime	3 x 10 <sup>9</sup> revolutions			
Working temperature range		-20 ... + 100 °C	-20 ... + 100 °C	-20 ... + 100 °C
Storage temperature range (without package)		-40 ... + 100 °C	-40 ... + 100 °C	-40 ... + 100 °C
Permissible relative humidity <sup>2)</sup>	90 %			
<b>EMC <sup>3)</sup></b>				
Resistance	To shocks <sup>4)</sup>	50 g/6 ms	70 g/6 ms	60 g/6 ms
	To vibration <sup>5)</sup>	20 g/10 ... 2000 Hz	30 g/10 ... 2000 Hz	20 g/10 ... 2000 Hz
<b>Protection class to IEC 60529</b>				
Shaft		IP 65	IP 65	IP 65
Housing side	Cable outlet	IP 67	IP 67	IP 67
Load current	4.5 ... 5.5 V, TTL/RS422	max. 30 mA	max. 30 mA	max. 30 mA
	10 ... 32 V, TTL/RS422	max. 30 mA	max. 30 mA	max. 30 mA
	10 ... 32 V, HTL/push-pull	max. 30 mA	max. 30 mA	max. 30 mA
	4,5 ... 32 V, TTL/HTL programmable			max. 30 mA
No-load operating current	4.5 ... 5.5 V, TTL/RS422	40 mA	40 mA	40 mA
	10 ... 32 V, TTL/RS422	40 mA	40 mA	40 mA
	10 ... 32 V, HTL/push-pull	40 mA	40 mA	40 mA
	4,5 ... 32 V, TTL/HTL programmable			60 mA
Initialisation time after power on	4.5 ... 5.5 V, TTL/RS422	40 ms	40 ms	40 ms
	10 ... 32 V, TTL/RS422	40 ms	40 ms	40 ms
	10 ... 32 V, HTL/ Push pull	40 ms	40 ms	40 ms
	4,5 ... 32 V, TTL/HTL programmable			max. 30 ms

<sup>1)</sup> Self-warming 3.3k/1,000 min<sup>-1</sup>  
when applying, note working temperature range

<sup>4)</sup> To EN 60068-2-27

<sup>5)</sup> To EN 60068-2-6

<sup>2)</sup> Condensation of the optical scanning not permitted

<sup>3)</sup> To EN 61000-6-2 and EN 61000-6-4

## Order information TTL and HTL interface

## Motor Feedback System VFS60, through hollow shaft plastic

Point 1	Point 2	Point 3	Point 4	Point 5	Point 6	Point 7	Point 8	Point 9	Point 10	Point 11	Point 12	Point 13	Point 14	Point 15	Point 16
V	F	S	6	0		-	T								

Type (cp. technical data page 11)	Mechanical interface	Electrical interface	Connection type	No. of lines
E	<b>Through hollow shaft</b>	4.5 ... 5.5 V, TTL/RS422 = <b>A</b>	Cable 8-core, universal 0.5 m <sup>1)</sup> = <b>J</b>	Always 5 characters in clear text
B	Plastic 3/8" = <b>3</b>	10 ... 32 V, TTL/RS422 = <b>C</b>	Cable 8-core, universal 1.5 m <sup>1)</sup> = <b>K</b>	Selection depending on the type, see below.
	Plastic 10 mm = <b>4</b>	10 ... 32 V, HTL/Push pull = <b>E</b>		
	Plastic 12 mm = <b>5</b>			
	Plastic 1/2" = <b>6</b>			
	Plastic 14 mm = <b>7</b>			
	Plastic 15 mm = <b>8</b>			

<sup>1)</sup> The universal cable outlet is positioned in such a way, that it is possible to lay the cable in a radial or axial direction without kinking it.

## Type E - Number of lines per revolution

01000	01024	02000	02048	Others on request
-------	-------	-------	-------	-------------------

## Type B - Number of lines per revolution

01000	02000	04096	16384	65536	Others on request
01024	02048	08192	32768		

## Order example Motor Feedback System VFS60, type E, through hollow shaft 10 mm,

### Electrical interface 10 ... 32 V, HTL/push-pull, cable 8-core, universal 0.5 m, number of lines 1024

Point 1	Point 2	Point 3	Point 4	Point 5	Point 6	Point 7	Point 8	Point 9	Point 10	Point 11	Point 12	Point 13	Point 14	Point 15	Point 16
V	F	S	6	0	E	-	T	4	E	J	0	1	0	2	4

**Order information TTL or HTL programmable**

**Motor Feedback System VFS60, through hollow shaft plastic**

Point 1	Point 2	Point 3	Point 4	Point 5	Point 6	Point 7	Point 8	Point 9	Point 10	Point 11	Point 12	Point 13	Point 14	Point 15	Point 16
V	F	S	6	0		-	T								

Type (cp. technical data page 11)	Mechanical interface	Electrical interface	Connection type	No. of lines
A	<b>Through hollow shaft</b> Plastic 3/8" = 3 Plastic 10 mm = 4 Plastic 12 mm = 5 Plastic 1/2" = 6 Plastic 14 mm = 7 Plastic 15 mm = 8	4,5 ... 32 V, TTL/HTL programmable = P	Cable 8-core, universal 0.5 m <sup>1)</sup> = J Cable 8-core universal 1.5 m <sup>1)</sup> = K	Factory-programmed to 1024

<sup>1)</sup> The universal cable outlet is positioned in such a way, that it is possible to lay the cable in a radial or axial direction without kinking it.

**Order example Motor Feedback System VFS60, type A, through hollow shaft 14 mm, programmable number of lines from 1 ... 8192,**

**Electrical interface 5 ... 32 V, cable 8-core, universal 0.5 m**

Point 1	Point 2	Point 3	Point 4	Point 5	Point 6	Point 7	Point 8	Point 9	Point 10	Point 11	Point 12	Point 13	Point 14	Point 15	Point 16
V	F	S	6	0	A	-	T	7	P	J	0	1	0	2	4

Factory-programmed number of lines: 1024, level of output signal: TTL

**Programming Tool for VFS60**

Type	Part no.	Contacts
PGT-08-S	1036616	12



**Adapter cable PGT-08-S incremental with Cable connector SUB-D 9-pin male and cable connector M12 8-pin female, ready-made with cable 8-core, 4 x 2 x 0,08 mm<sup>2</sup>, with screening**

Type	Part no.
DSL-2D08-G0M5AC3	2046579

**Adapter cable PGT-08-S incremental with Cable connector SUB-D 9-pin male and cable connector M23 12-pin female, ready-made with cable 8-core, 4 x 2 x 0,08 mm<sup>2</sup>, with screening**

Type	Part no.
DSL-3D08-G0M5AC3	2046580

## Interfaces

## Electrical interfaces

Supply voltage	4.5 ... 5.5 V	10 ... 32 V	10 ... 32 V	5 ... 32 V
Output	TTL/RS422	TTL/RS422	HTL/push-pull	HTL/TTL programmable

## Incremental pulse diagram

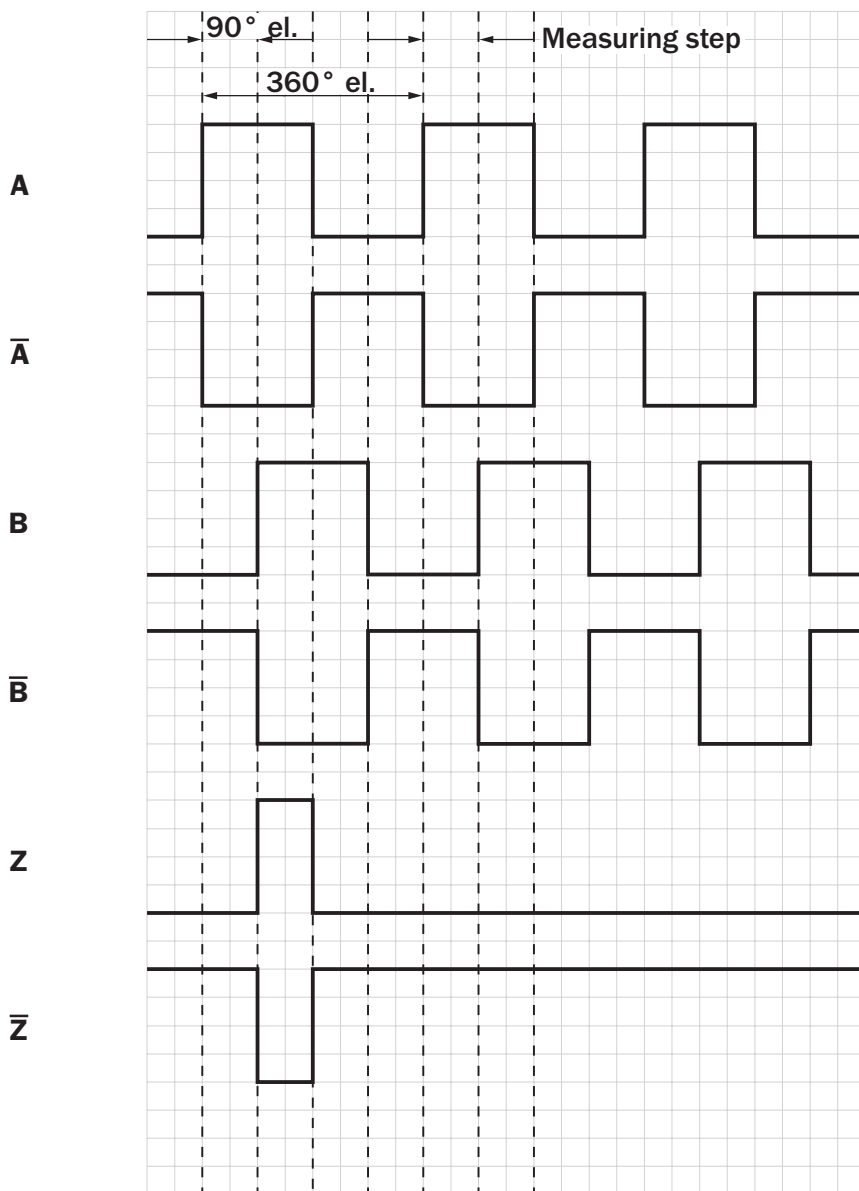

CW with view on the encoder shaft in direction "A", see dimensional drawing.

AUDIN - 8, avenue de la malle - 51370 Saint Brice Courcelles

**Programming Tool**

**Programming Tool for VFS60**

Type	Part no.	Contacts
PGT-08-S	1036616	12



**Adapter cable PGT-08-S incremental with Cable connector SUB-D 9-pin male and cable connector M12 8-pin female, ready-made with cable 8-core, 4 x 2 x 0,08 mm<sup>2</sup>, with screening**

Type	Part no.
DSL-2D08-GOM5AC3	2046579

**Adapter cable PGT-08-S incremental with Cable connector SUB-D 9-pin male and cable connector M23 12-pin female, ready-made with cable 8-core, 4 x 2 x 0,08 mm<sup>2</sup>, with screening**

Type	Part no.
DSL-3D08-GOM5AC3	2046580

**Zero pulse width 90°, 180° or 270° programmable**

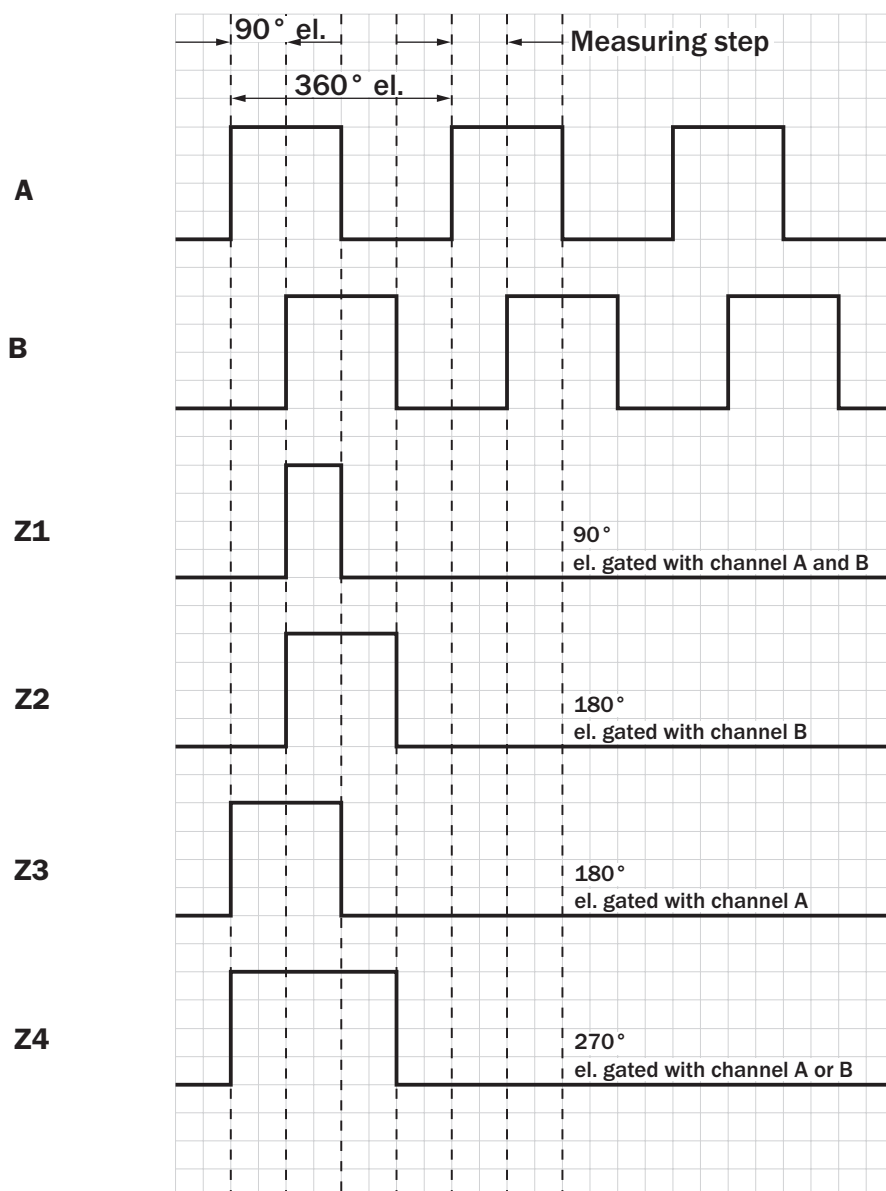

CW with view on the encoder shaft in direction "A"

Dimensional drawings and ordering information

Screw-in system M23, 12-pin

Cable connector M23 female, 12-pin, straight, screened

Type	Part no.	Contacts
DOS-2312-G	6027538	12

Cable connector M23 male, 12-pin, straight, screened

Type	Part no.	Contacts
STE-2312-G	6027537	12

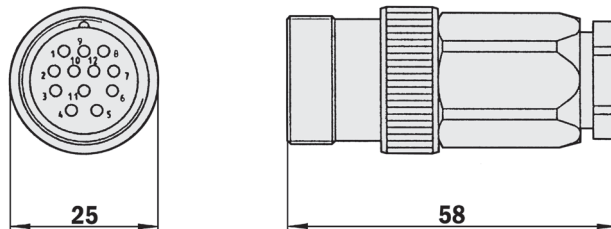
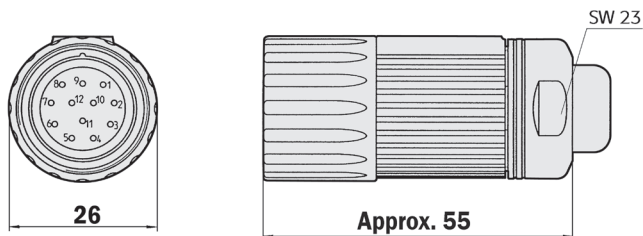

General tolerances according to DIN ISO 2768-mk

General tolerances according to DIN ISO 2768-mk

Cable connector M23 male, 12-pin, straight, screened, for rear panel installation

Type	Part no.	Contacts
STE-2312-GX	6028548	12

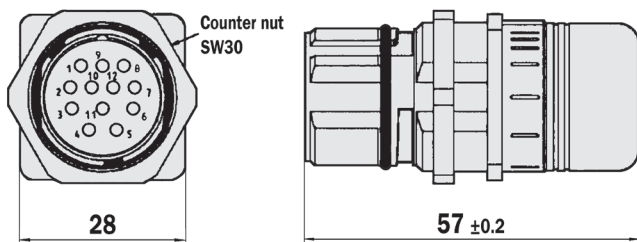

General tolerances according to DIN ISO 2768-mk

Cable connector M23 female, 12-pin, straight, cable 11-core, 4 x 2 x 0.25 + 2 x 0.5 + 1 x 0.14 mm<sup>2</sup> with screening, cable diameter 7.8 mm

Type	Part no.	Contacts	Cable length
DOL-2312-G02MLA3	2030682	12	2.0 m
DOL-2312-G07MLA3	2030685	12	7.0 m
DOL-2312-G10MLA3	2030688	12	10.0 m
DOL-2312-G15MLA3	2030692	12	15.0 m
DOL-2312-G20MLA3	2030695	12	20.0 m
DOL-2312-G25MLA3	2030699	12	25.0 m
DOL-2312-G30MLA3	2030702	12	30.0 m

Cable connector M23 female, 12-pin, straight, cable 11-core, 4 x 2 x 0.25 + 2 x 0.5 + 2 x 0.14 mm<sup>2</sup> with screening, capable of being dragged, cable diameter 7.8 mm

Type	Part no.	Contacts	Cable length
DOL-2312-G1M5MA3	2029212	12	1.5 m
DOL-2312-G03MMA3	2029213	12	3.0 m
DOL-2312-G05MMA3	2029214	12	5.0 m
DOL-2312-G10MMA3	2029215	12	10.0 m
DOL-2312-G20MMA3	2029216	12	20.0 m
DOL-2312-G30MMA3	2029217	12	30.0 m



## Dimensional drawings and ordering information

## Cables

Cable 8-core, per metre, 4 x 2 x 0.15 mm<sup>2</sup>, with screening, cable diameter 5.6 mm

Type	Part no.	Wires
LTG-2308-MWENC	6027529	8

Cable 11-core, per metre, 4 x 2 x 0.25 + 2 x 0.5 + 1 x 0.14 mm<sup>2</sup>, with screening, cable diameter 7.5 mm

Type	Part no.	Wires
LTG-2411-MW	6027530	11

Cable 12-core, per metre, 4 x 2 x 0.25 + 2 x 0.5 + 2 x 0.14 mm<sup>2</sup>, with screening, capable of being dragged, cable diameter 7.8 mm

Type	Part no.	Wires
LTG-2512-MW	6027531	12

Cable 12-core, per metre, 4 x 2 x 0.25 + 2 x 0.5 + 2 x 0.14 mm<sup>2</sup>, with screening, capable of being dragged, cable diameter 7.8 mm

Type	Part no.	Wires	Explanation
LTG-2612-MW	6028516	12	UV and salt water resistant

Cable 8-core inc. sealing, 4 x 2 x 0.15 mm<sup>2</sup>, with screening, cable diameter 5.6 mm

Type	Part no.	Cable length
DOL-0J08-G0M5AA3	2046873	0.5 m
DOL-0J08-G1M5AA3	2046874	1.5 m
DOL-0J08-G03MAA3	2046875	3.0 m
DOL-0J08-G05MAA3	2046876	5.0 m
DOL-0J08-G10MAA3	2046877	10.0 m



Further mounting versions

Version 1

Type	Part no.
BEF-DS01DFS/VFS	2047428

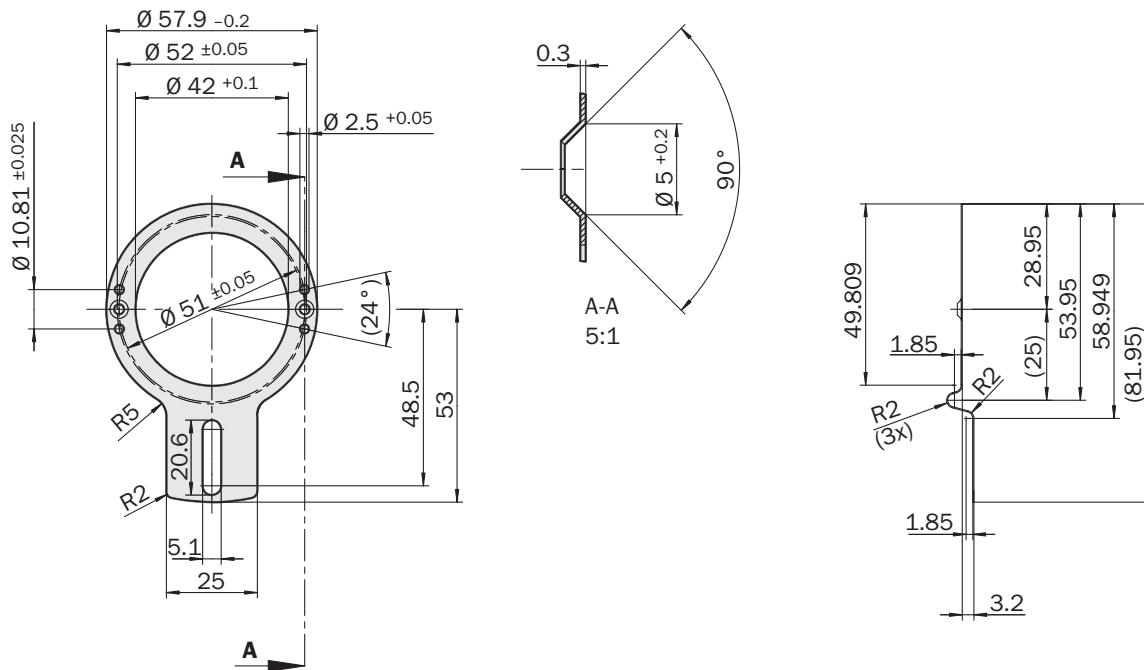

Version 2

Type	Part no.
BEF-DS02DFS/VFS	2047430

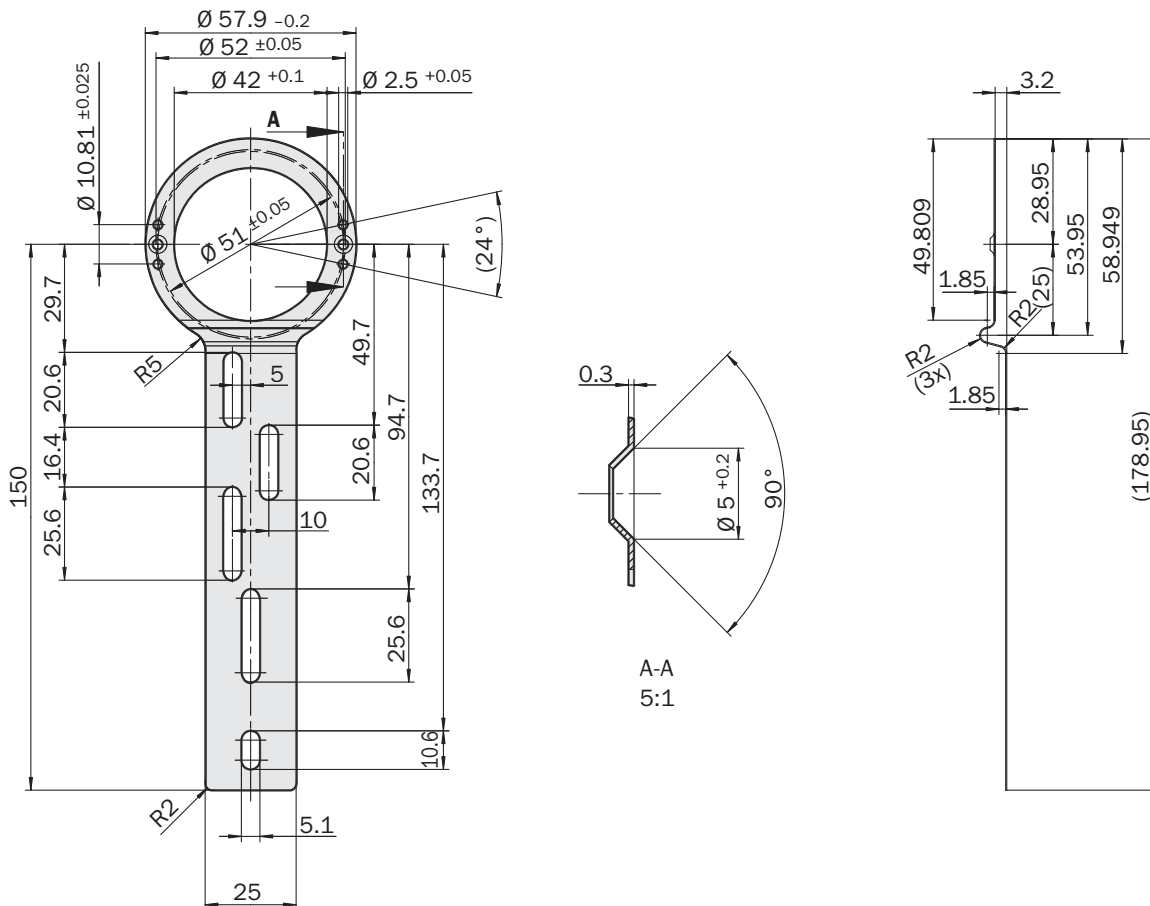

Further mounting versions

Version 3

Type	Part no.
BEF-DS03DFS/VFS	2047431

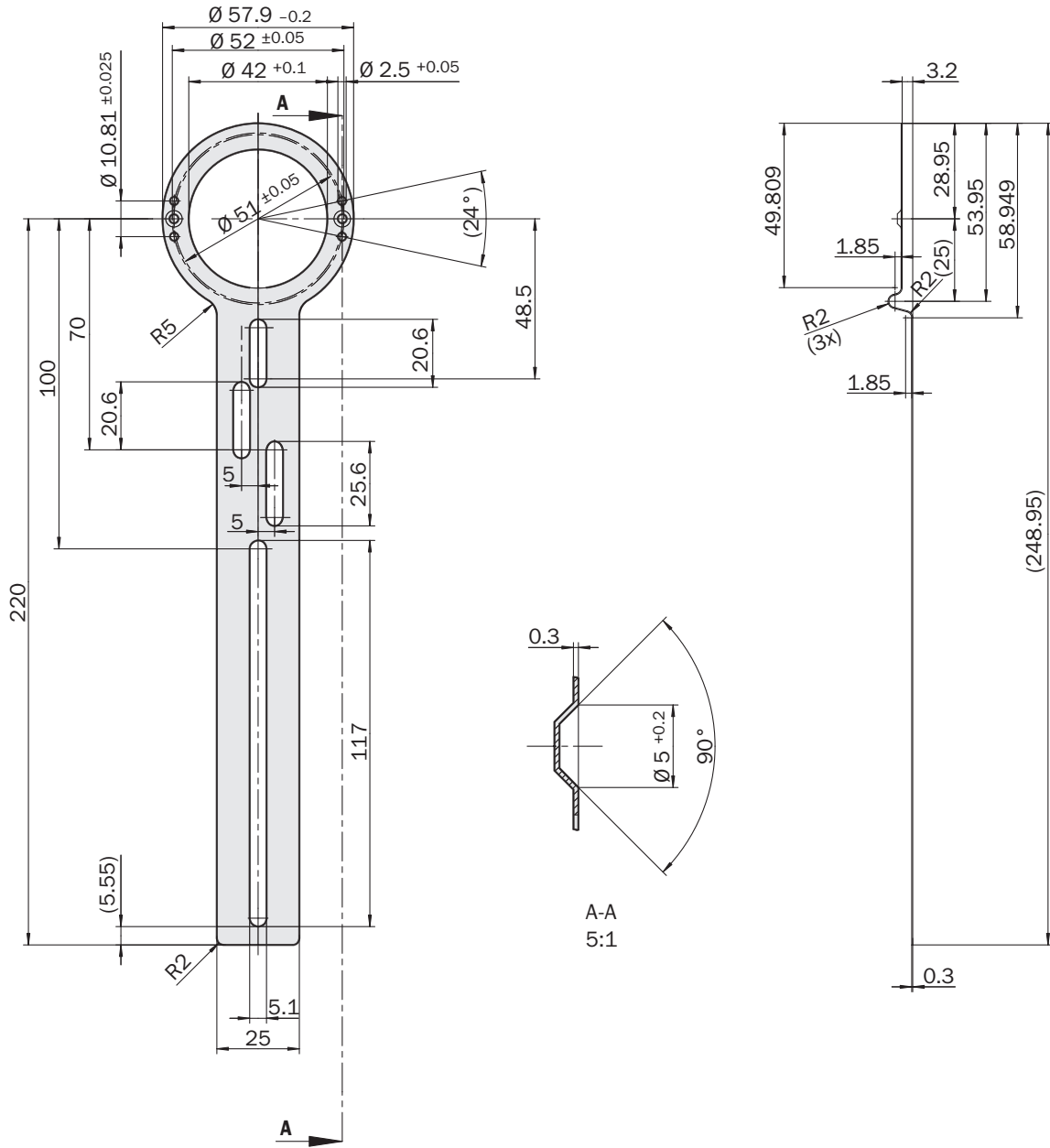

**Australia**

Phone +61 3 9497 4100  
1800 33 48 02 - tollfree  
E-Mail sales@sick.com.au

**Belgium/Luxembourg**

Phone +32 (0)2 466 55 66  
E-Mail info@sick.be

**Brasil**

Phone +55 11 3215-4900  
E-Mail sac@sick.com.br

**Ceská Republika**

Phone +420 2 57 91 18 50  
E-Mail sick@sick.cz

**China**

Phone +852-2763 6966  
E-Mail ghk@sick.com.hk

**Danmark**

Phone +45 45 82 64 00  
E-Mail sick@sick.dk

**Deutschland**

Phone +49 211 5301-250  
E-Mail info@sick.de

**España**

Phone +34 93 480 31 00  
E-Mail info@sick.es

**France**

Phone +33 1 64 62 35 00  
E-Mail info@sick.fr

**Great Britain**

Phone +44 (0)1727 831121  
E-Mail info@sick.co.uk

**India**

Phone +91-22-4033 8333  
E-Mail info@sick-india.com

**Israel**

Phone +972-4-999-0590  
E-Mail info@sick-sensors.com

**Italia**

Phone +39 02 27 43 41  
E-Mail info@sick.it

**Japan**

Phone +81 (0)3 3358 1341  
E-Mail support@sick.jp

**Nederlands**

Phone +31 (0)30 229 25 44  
E-Mail info@sick.nl

**Norge**

Phone +47 67 81 50 00  
E-Mail austefjord@sick.no

**Österreich**

Phone +43 (0)22 36 62 28 8-0  
E-Mail office@sick.at

**Polska**

Phone +48 22 837 40 50  
E-Mail info@sick.pl

**Republic of Korea**

Phone +82-2 786 6321/4  
E-Mail kang@sickkorea.net

**Republika Slovenija**

Phone +386 (0)1-47 69 990  
E-Mail office@sick.si

**România**

Phone +40 356 171 120  
E-Mail office@sick.ro

**Russia**

Phone +7 495 775 05 34  
E-Mail info@sick-automation.ru

**Schweiz**

Phone +41 41 619 29 39  
E-Mail contact@sick.ch

**Singapore**

Phone +65 6744 3732  
E-Mail admin@sicksgp.com.sg

**Suomi**

Phone +358-9-25 15 800  
E-Mail sick@sick.fi

**Sverige**

Phone +46 10 110 10 00  
E-Mail info@sick.se

**Taiwan**

Phone +886 2 2375-6288  
E-Mail sales@sick.com.tw

**Türkiye**

Phone +90 216 587 74 00  
E-Mail info@sick.com.tr

**United Arab Emirates**

Phone +971 4 8865 878  
E-Mail info@sick.ae

**USA/Canada/México**

Phone +1(952) 941-6780  
1 800-325-7425 - tollfree  
E-Mail info@sickusa.com

More representatives and agencies  
in all major industrial nations at  
**www.sick.com**