



RK ROSE+KRIEGER

Charges moyennes à lourdes | Aluminium

Raccords tubulaires perpendiculairesp. 54

Raccords tubulaires parallèles à l'axe.....p. 124

Raccords tubulaires articulés.....p. 158

Accessoiresp. 208

Solid Clamps



...Des techniques d'assemblage de tubes haute précision en aluminium

■ Raccords tubulaires perpendiculaires

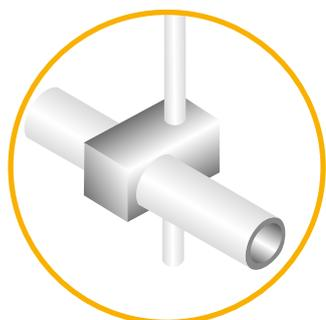

Raccords orthogonaux

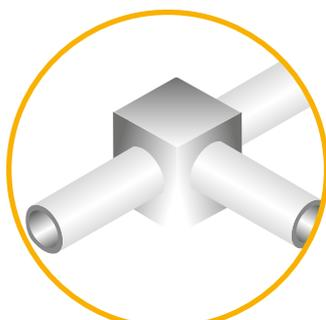

Raccords d'angle

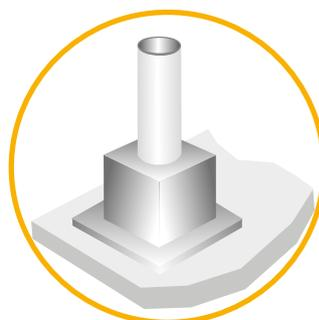

Pieds

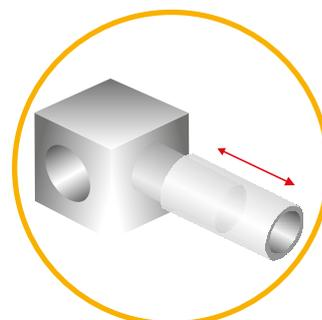

Colliers emboîtables

■ Raccords tubulaires parallèles à l'axe

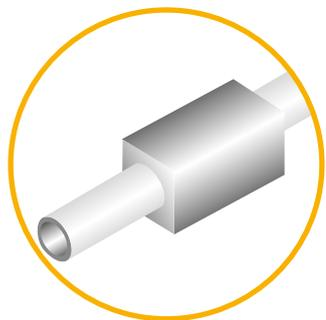

Raccords droits

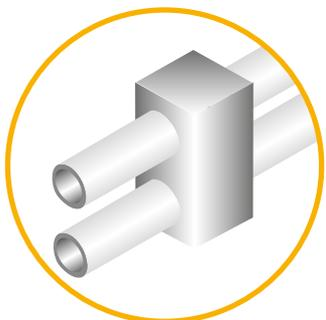

Raccords parallèles

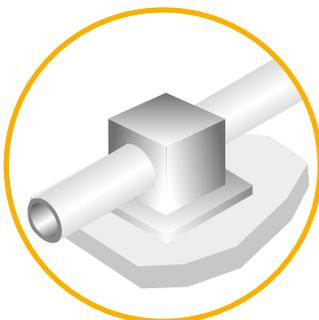

Brides de fixation

■ Raccords tubulaires articulés

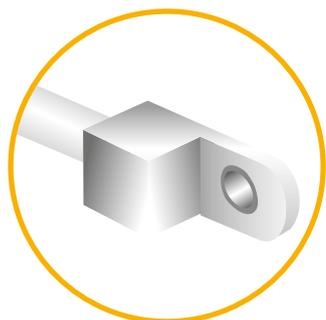

Raccords à collier

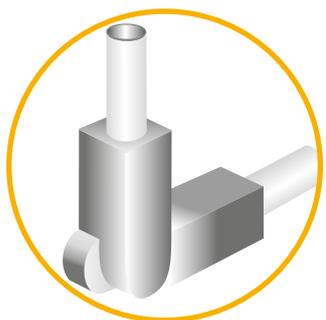

Raccords orientables

Table des matières Solid Clamps

Raccords tubulaires perpendiculaires

(éléments monoblocs et en plusieurs parties)

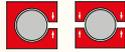

- Raccords orthogonaux p. 54
- Raccords d'angle p. 70
- Pieds p. 92
- Colliers emboîtables p. 114

Raccords tubulaires parallèles à l'axe

(éléments monoblocs et en plusieurs parties)

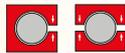

- Raccords droits p. 124
- Raccords parallèles p. 134
- Brides de fixation p. 140

Raccords tubulaires articulés

(éléments monoblocs et en plusieurs parties)

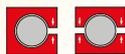

- Raccords à collier p. 158
- Raccords orientables p. 170

Accessoires

- Ensemble des accessoires à partir de la p. 208



Versions:

■ Raccords orthogonaux

Livrable sur stock

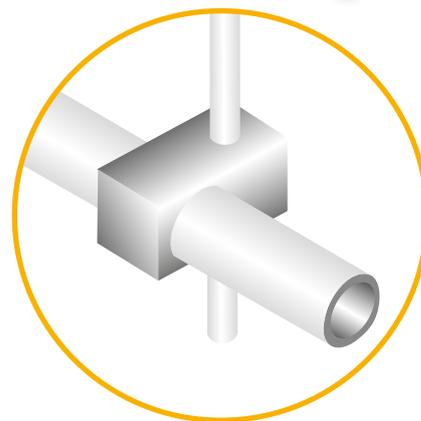

Éléments monoblocs

✓ Pour un montage plus rapide et économique



Série industrie

- Fonte d'aluminium
- Grande diversité
- Éléments monoblocs



Série quad®

- Profilé en aluminium extrudé
- Contrainte de couple maximale
- Surface anodisée haute qualité
- Éléments monoblocs et en plusieurs parties



Éléments en plusieurs parties

✓ Également conçus pour les montages et extensions a posteriori



Série quad®

- Profilé en aluminium extrudé
- Contrainte de couple maximale
- Surface anodisée haute qualité
- Éléments monoblocs et en plusieurs parties



Série bloc

- Fonte d'aluminium
- Contrainte de couple plus élevée
- Contours extérieurs plans
- Éléments en plusieurs parties

Charges admissibles

ATTENTION !

Les valeurs données dans les tableaux ne constituent pas un engagement sur les valeurs ni une garantie de résultat à propos de nos produits.

Il ne s'agit que de valeurs indicatives non contractuelles, qui peuvent dans certains cas ne pas être atteintes, dépendant notamment de divers facteurs liés aux applications, comme la température ou la nature de la surface des tubes.

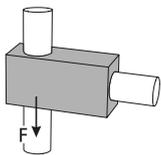

Adhérence F [KN]

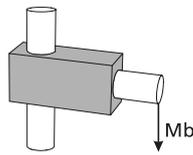

Moment de flexion Mb [Nm]

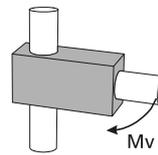

Couple de torsion Mv [Nm]

Couple de serrage des vis:

M6: 10 Nm

M8: 25 Nm

M10: 50 Nm

Talle Type	18			30			40			50			60			80		
	F	Mb	Mv	F	Mb	Mv	F	Mb	Mv	F	Mb	Mv	F	Mb	Mv	F	Mb	Mv
Série industrie																		
K	2,2	126	24	5,8	368	84	4,8	750	43	12,7	1025	368	16	1900	497			
KD				6,9	420	92	9,0	1148	103	2	948	63	16	1900	359			
KR				7,0	396	49	5,5	866	43									
KVR						49	5,0	335	43									
KRR				6,7	713	93	5,5	1131	84									
KV				3,0	393	280	2,8	338	692									
KDVR				6,7	328	249	6,3	198	118									

Talle Type	18			30			40			50			60			80		
	F	Mb	Mv	F	Mb	Mv	F	Mb	Mv	F	Mb	Mv	F	Mb	Mv	F	Mb	Mv
Série bloc																		
KR										9,4	1250	253						
KVR										9,4	1250	253						
KRR				5,1	831	99	5,7	512	114	9,4	1270	254	12,5	1625	261	11	1750	594
KV				2,6	425	429	3,1	512	698	5,9	823	743	7,8	1390	1208	18	1535	2183
KVRR				2,6	831	421	5,7	512	114	13,7	1270	254	7,6	1433	1191	18	1601	2275

Talle Type	18			30			40			50			60			80		
	F	Mb	Mv	F	Mb	Mv	F	Mb	Mv	F	Mb	Mv	F	Mb	Mv	F	Mb	Mv
Série quad®																		
K				2	738	51	4,0	960	59	6,9	1250	167						
KD				1	847	61	5,3	1075	62	3,9	1250	59						
KRR				6	1139	50	7,6	1125	121	11,5	1250	272						
KRD				6	1045	41	7,6	1125	121	7,6	1250	121						
KVR				5	854	50	8,1	1001	121	7,5	1750	272						
KV				5	754	303	8,1	804	375	7,5	960	1207						

Solid Clamps – Raccords orthogonaux

Raccords tubulaires perpendiculaires

Série industrie



Série blocs

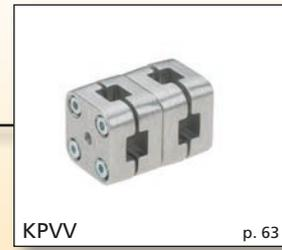

Série quad®

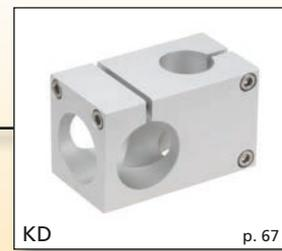
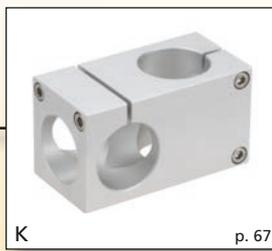

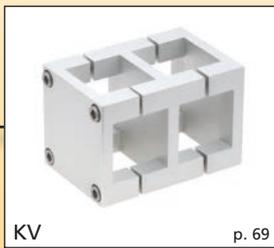
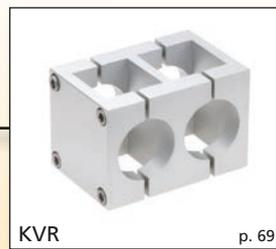

Solid Clamps – Raccords orthogonaux

Principe de commande:

- Pièce standard, pré montée avec des vis en acier galvanisé
- Levier de serrage à commander séparément. Livré non monté. Voir dernière colonne du tableau et page 222

Sur demande:

- Vis en acier inoxydable
- En couleur
- Polissage à billes

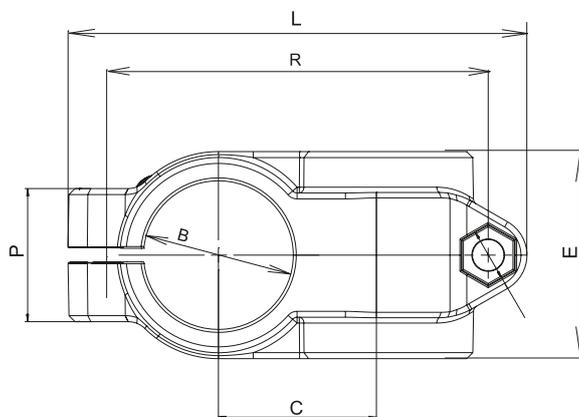
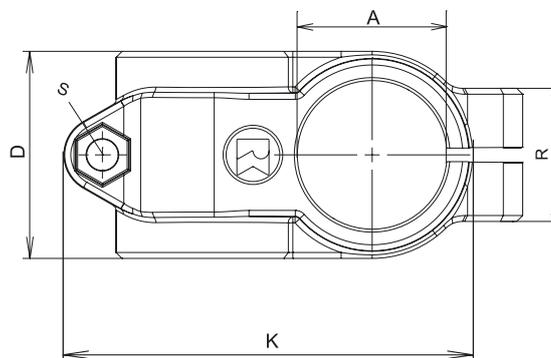

K - Série industrie

[mm]

Code No.	Type	A	B	C	D	E	K	L	P	R	m [g]	Levier de serrage S Code No.
101200000200	K 12	12,1	12,1	20	25,5	25,5	43,5	67	23	49	75	90209
101400000200	K 14	14,1	14,1								70	
101500000200	K 15	15,1	15,1								67	
101600000200	K 16	16,1	16,1								64	
101800000200	K 18	18,1	18,1								57	
102000000200	K 20	20,1	20,1	33	40	40	73	99	33	78	252	9022201
102500000200	K 25	25,1	25,1								217	
	K 28*	*Avec machon adaptateur R28, voir accessoires page 223										
103000000200	K 30	30,1	30,1	33	40	40	73	99	33	78	173	9022201
103020000200	K 30x20		20,1								195	
103025000200	K 30x25		25,1								195	
103002000200	K 30x32	30,1	30,1	45	60	60	119	137	40	111	665	90250
103200000200	K 32	32,17	32,17								665	
103500000200	K 35	35,17	35,17								617	
104000000200	K 40	40,17	40,17								527	
104200000200	K 42	42,22	42,22								907	
104800000200	K 48	48,22	48,22	53	70	70	119	154	45	128	755	90251
105000000200	K 50	50,2	50,2								699	
105040000200	K 50/40	50,22	40,17								827	
106000000200	K 60	60,27	60,25	65	80	80	142,5	190	58	158	1101	9025301
108000000200	K 80	80,35	80,35	90	120	120	200	255	82	210	3870	9025301

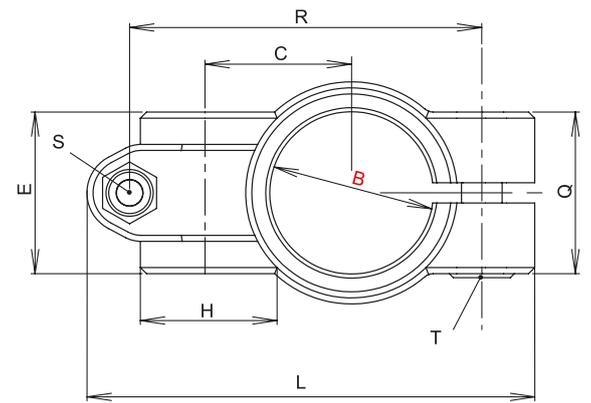
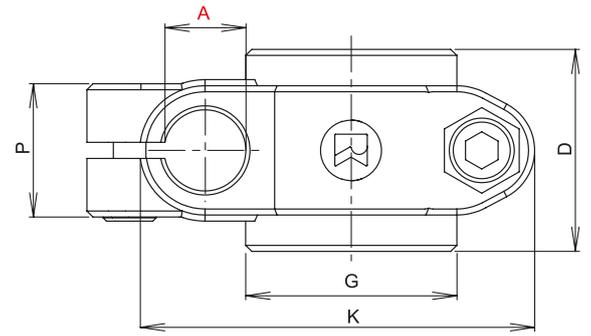
KD - Série industrie

[mm]

Code No.	Type	A	B	C	D	E	G	H	K	L	P	Q	R	m [g]	S	T
															Levier de serrage Code No.	
102012010200	KD 20x12	12,1	20,1	27	40	33	40	23,5	60	84	21	33	65	175	90209	9022201
102014010200	KD 20x14	14,1														
102015010200	KD 20x15	15,1														
102016010200	KD 20x16	16,1														
102018010200	KD 20x18	18,1														
102512010200	KD 25x12	12,1	25,1	27	40	33	40	23,5	60	84	21	33	65	154	90209	9022202
102514010200	KD 25x14	14,1														
102515010200	KD 25x15	15,1														
102516010200	KD 25x16	16,1														
102518010200	KD 25x18	18,1														
	KD 28*	*Avec machon adaptateur R28, voir accessoires page 223														
103012010200	KD 30x12	12,1	30,1	27	40	33	40	23,5	60	84	21	33	65	135	90209	9022202
103014010200	KD 30x14	14,1														
103015010200	KD 30x15	15,1														
103016010200	KD 30x16	16,1														
103018010200	KD 30x18	18,1														
103220010200	KD 32x20	20	32,2	36	50	40	52	32	78	110	33	40	86,5	283	9022201	90250
103520010200	KD 35x20	35,2														
104020010200	KD 40x20	20,1	40,17	45	65	65	65	45	60	110	33	40	86,5	250	90251	90251
104030010200	KD 40(42)x30	30,1	40,17													
104230010200	KD 42x30	30,1	42,2	45	65	65	66	48	102	126	43	58	102	640	90251	90251
105025010200	KD 50x25	25,1	50,22													
105030010200	KD 50x30	30,1	50,22	45	65	49	65	45	60	137,5	44	44	108,5	576	90251	90251
106040010200	KD 60x40	60,27	40,22													
106048010200	KD 60x48	48,27	60,27	60	80	70	75	65	130	180	53	58	148	1163	9025501	9025301
106050010200	KD 60x50	50,27														
106250010200	KD 62x50															

Solid Clamps – Raccords orthogonaux

Principe de commande:

- Pièce standard, pré montée avec des vis en acier galvanisé
- Levier de serrage à commander séparément. Livré non monté. Voir dernière colonne du tableau et p. 222

Sur demande:

- Vis en acier inoxydable
- En couleur
- Polissage à billes

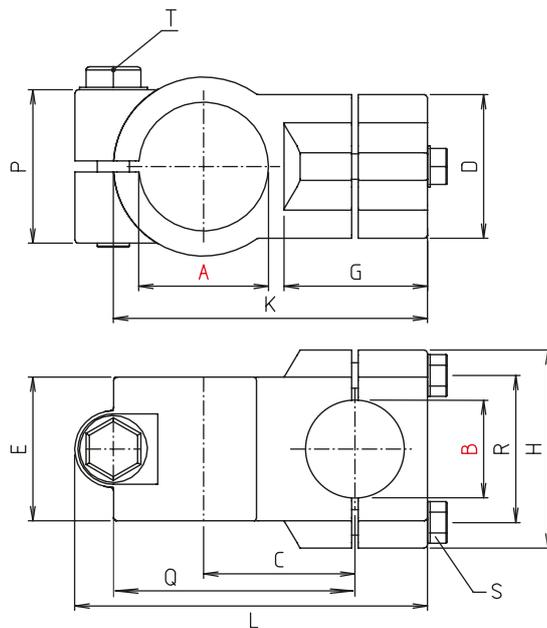
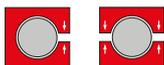

KR - Série industrie

[mm]

Code No.	Type	A	B	C	D	E	G	H	K	L	P	Q	R	m [g]	S	T
															Levier de serrage Code No.	
102000020200	KR 20	20,1	20,1	33	45	45	40	62	74,5	85	33	55	46	338	9022401	9022401
102500020200	KR 25	25,1	25,1													
	KR 28*	*Avec machon adaptateur R28, voir accessoires page 223														
103000020200	KR 30	30,1	30,1	33	45	45	40	62	74,5	85	33	55	46	257	9022401	9022401
103500020200	KR 35	35,2	35,2	47	60	60	60	75	105	117	48	75	57	622	9022501	9024301
104000020200	KR 40	40,2	40,2													

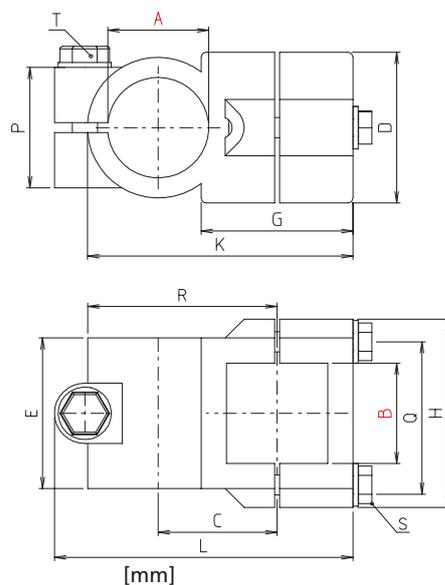
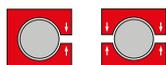

KVR - Série industrie

Code No.	Type	A	B	C	D	E	G	H	K	L	P	Q	R	m [g]	S	T
															Levier de serrage Code No.	
102000040200	KVR 20	20,1	20,2	33	45	45	40	62	74,5	85	33	46	55	332	9022401	9022401
102500040200	KVR 25	25,1	25,2													
	KVR 28*	*Avec machon adaptateur R28, voir accessoires page 223														
103000040200	KVR 30	30,1	30,2	33	45	45	40	62	74,5	85	33	46	55	245	9022401	9022401
103500040200	KVR 35	35,2	35,3	47	60	60	60	75	105	117	48	57	75	599	9022501	9024301
104000040200	KVR 40	40,2	40,3													

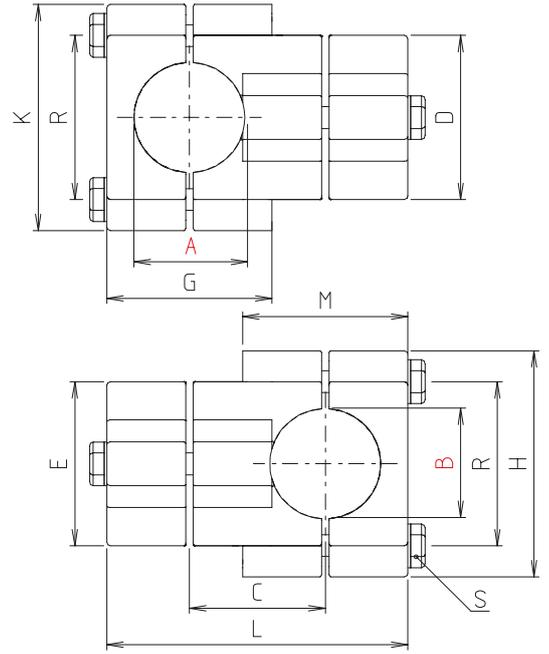

KRR - Série industrie

[mm]

Code No.	Type	A	B	C	D	E	G	H	K	L	M	R	m [g]	Levier de serrage S Code No.
102500030200	KRR 25	25,2	25,2	38	45	45	45	64	64	83	45	46	369	9022501
103000030200	KRR 30	30,2	30,2										352	
103500030200	KRR 35	35,2	35,2	50	60	60	60	77	77	110	60	57	668	9022801
104000030200	KRR 40	40,2	40,2										645	

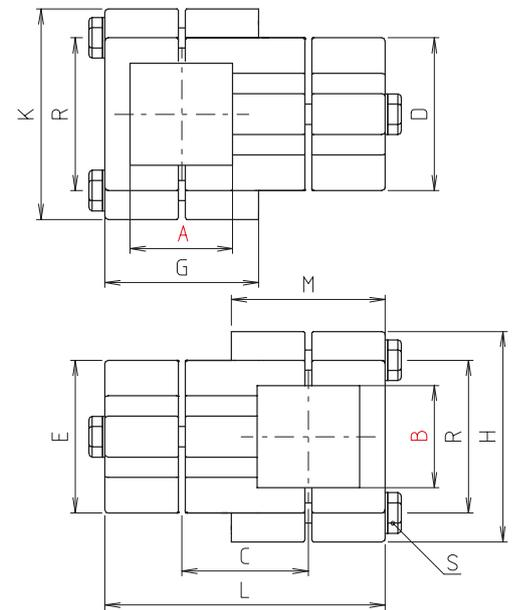

KV - Série industrie

[mm]

Code No.	Type	A	B	C	D	E	G	H	K	L	M	R	m [g]	Levier de serrage S Code No.
102000050200	KV 20	20,3	20,3	38	45	45	44	64	64	83	44	46	385	9022601
102500050200	KV 25	25,2	25,2										353	
103000050200	KV 30	30,2	30,2	50	60	60	60	77	77	110	60	57	321	9022501
103500050200	KV 35	35,3	35,3										637	
104000050200	KV 40	40,3	40,3	584	9022801									

Solid Clamps – Raccords orthogonaux

Principe de commande:

- Pièce standard, pré montée avec des vis en acier galvanisé
- Levier de serrage à commander séparément. Livré non monté. Voir dernière colonne du tableau et page 222

Sur demande:

- Vis en acier inoxydable
- En couleur
- Polissage à billes

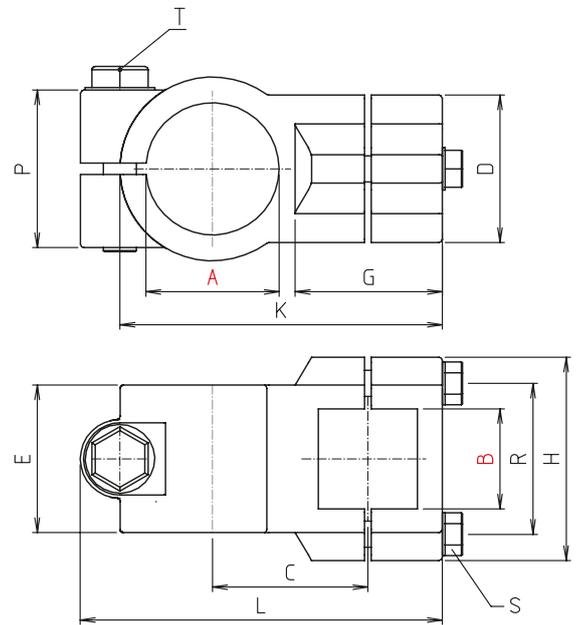
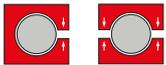

KDVR - Série industrie

[mm]

Code No.	Type	A	B	C	D	E	G	H	K	L	P	R	m [g]	S	T
														Levier de serrage S Code No.	
104020090200	KDVR 20-40	40,3	20,2	47	45	45	45	62	98	110	48	46	408	9022401	9024301
104025090200	KDVR 25-40		25,2												
104030090200	KDVR 30-40		30,2												

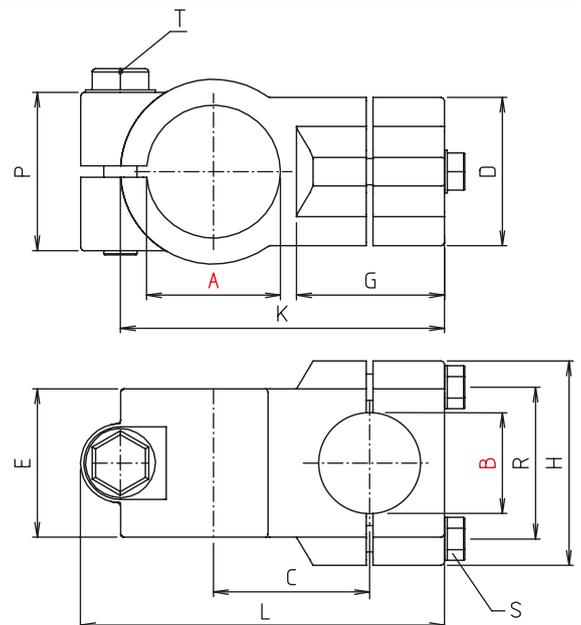
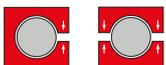

KDRR - Série industrie

[mm]

Code No.	Type	A	B	C	D	E	G	H	K	L	P	R	m [g]	S	T
														Levier de serrage S Code No.	
102040110200	KDRR 20-40	40,3	20	47	45	45	45	62	98	110	48	46	452	9022401	9024301
102540110200	KDRR 25-40		25,1												

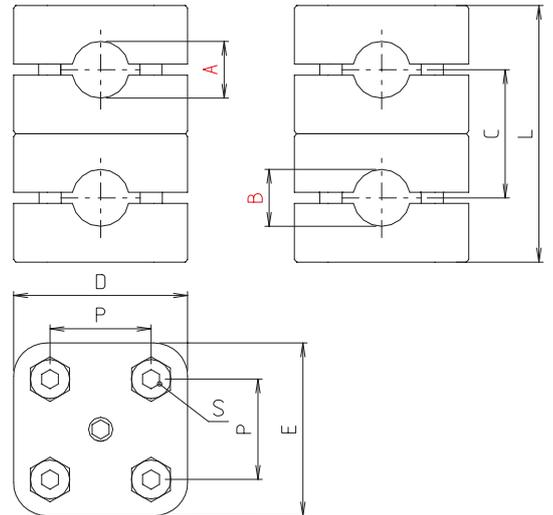

KPRR - Série blocs

[mm]

Code No.	Type	A	B	C	D	E	L	P	S	m [g]
290800000266	KPRR 8	8	8	23	31	31	46	18	M4x18	97
291000000266	KPRR 10	10	10							93

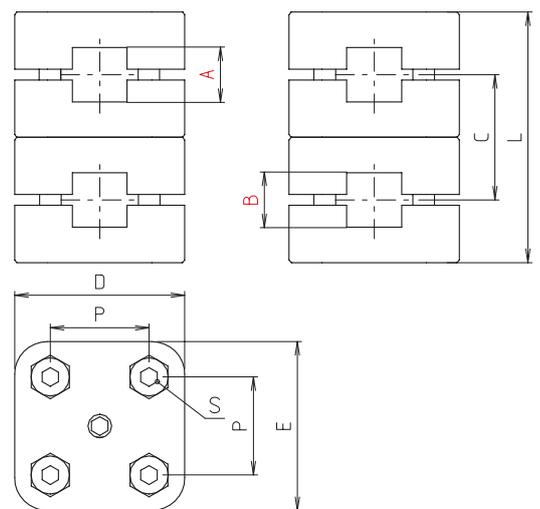

KPVV - Série blocs

[mm]

Code No.	Type	A	B	C	D	E	L	P	S	m [g]
291000010266	KPVV 10	10	10	23	31	31	46	18	M4x18	88

Solid Clamps – Raccords orthogonaux

Principe de commande:

- Pièce standard, pré montée avec des vis en acier galvanisé
- Levier de serrage à commander séparément. Livré non monté. Voir dernière colonne du tableau et page 222

Sur demande:

- Vis en acier inoxydable
- En couleur
- Polissage à billes

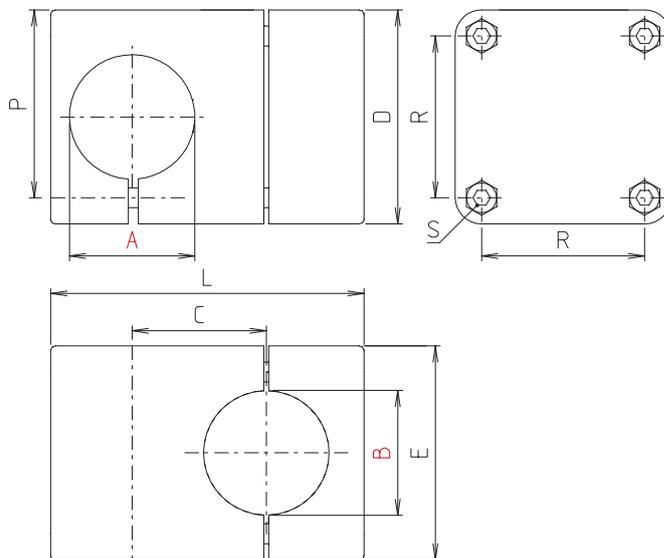
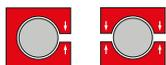

KR - Série locs

Code No.	Type	A	B	C	D	E	L	P	R	m [g]	S	T
											Levier de serrage S Code No.	
204200020266	KR 42	42,2	42,2	53	86	86	126	73	65	1367	9022601	9022701
204500020266	KR 45	45,2	45,2									
204800020266	KR 48	48,2	48,2									
205000020266	KR 50	50,2	50,2									

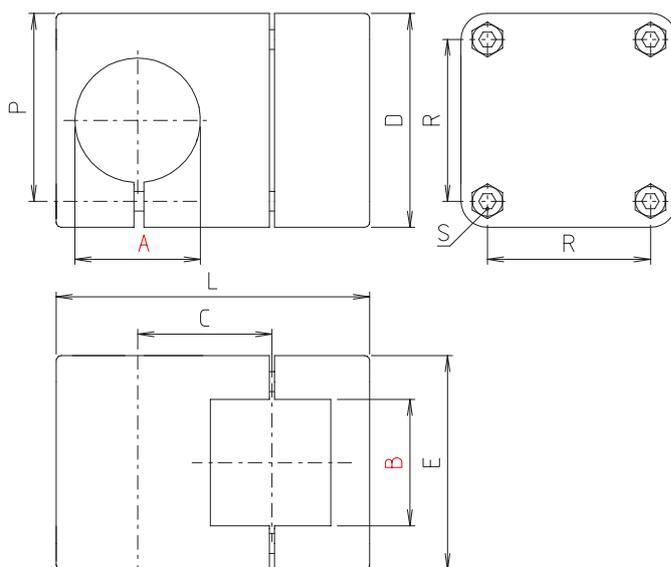
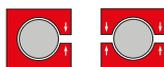

KVR - Série blocs

Code No.	Type	A	B	C	D	E	L	P	R	m [g]	S	T
											Levier de serrage S Code No.	
204850040266	KVR 48/50	48,2	50,5	53	86	86	126	73	65	1199	9022601	9022701
205000040266	KVR 50	50,2										

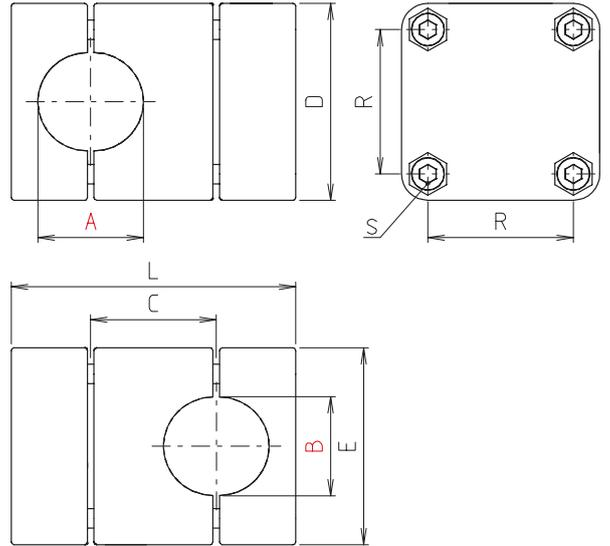

KRR - Série blocs

[mm]

Code No.	Type	A	B	C	D	E	L	R	m [g]	Levier de serrage S Code No.
203000030266	KRR 30	30,2	30,2	38	60	60	86	44	450	9021301
204000030266	KRR 40	40,3	40,3	50	70	70	112	53	688	9021501
204200030266	KRR 42	42,3	42,3	70	86	86	149	65	1614	9022801
204500030266	KRR 45	45,3	45,3						1579	
204800030266	KRR 48	48,3	48,3						1550	
205000030266	KRR 50	50,3	50,3						1520	
206000030266	KRR 60	60,4	60,4	80	100	100	170	78	2048	
208000030266	KRR 80	80,5	80,5	122	130	130	244	100	5075	9024601

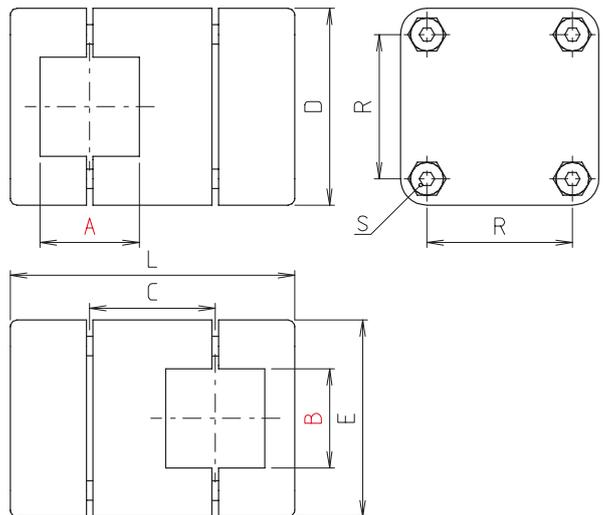

KV - Série blocs

[mm]

Code No.	Type	A	B	C	D	E	L	R	m [g]	Levier de serrage S Code No.
203000050266	KV 30	30,2	30,2	38	60	60	86	44	329	9021301
204000050266	KV 40	40,4	40,4	50	70	70	112	53	661	9021501
205000050266	KV 50	50,5	50,5	70	86	86	149	65	1427	9022801
206000050266	KV 60	60,6	60,6	80	100	100	170	78	1950	
208000050266	KV 80	80,7	80,7	122	130	130	244	100	4850	9024601

Solid Clamps – Raccords orthogonaux

Principe de commande:

- Blocs avec vis galvanisées
- quad® avec vis en acier inoxydable
- Levier de serrage à commander séparément. Livré non monté. Voir dernière colonne du tableau et page 222

Sur demande: Blocs:

- Vis en acier inoxydable
- Polissage à billes
- En couleur

Sur demande: Quad®:

- Anodisé noir

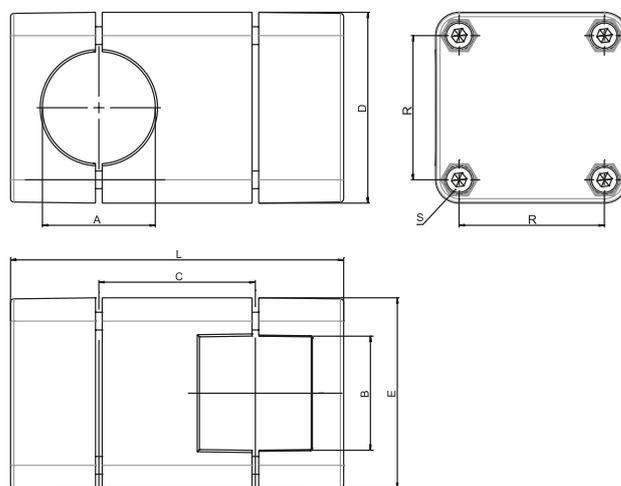
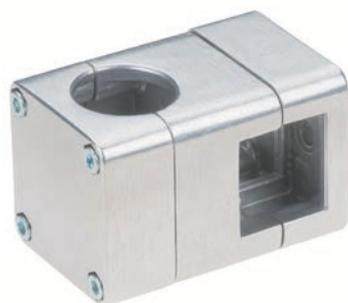

KVRR - Série blocs

[mm]

Code No.	Type	A	B	C	D	E	L	R	m [g]	Levier de serrage S Code No.
203000080266	KVRR 30	30,2	30,2	38	60	60	86	44	441	9021301
204000080266	KVRR 40	40,4	40,3	50	70	70	112	53	671	9021501
205000080266	KVRR 50	50,5	50,3	70	86	86	149	65	1477	9022801
206000080266	KVRR 60	60,6	60,4	80	100	100	170	78	1987	9022801
208000080266	KVRR 80	80,7	80,5	122	130	130	244	100	5075	9024601

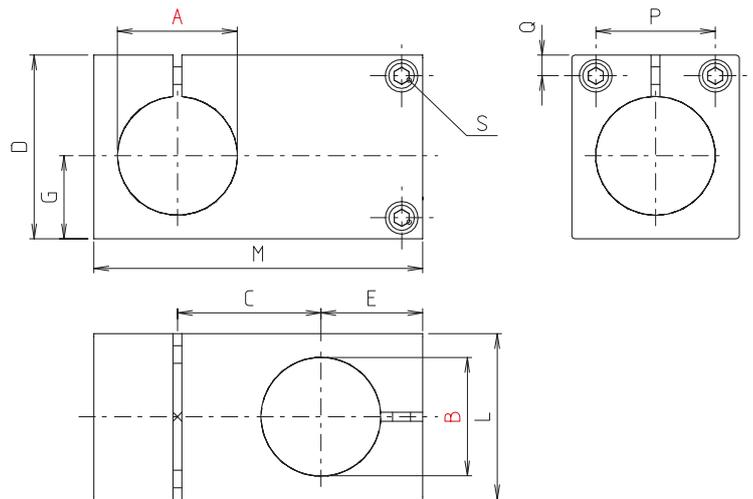

K - Série quad®

[mm]

Code No.	Type	A	B	C	D	E	G	L	M	P	Q	m [g]	S	T
													Levier de serrage Code No.	
503000000300	K 30	30,1	30,1	36	49	28	21	42	85	28	7	236	9301401	9300101
504000000300	K 40	40,1	40,1	48	62	34	28	56	110	42	7	490	9301701	9301401
505000000300	K 50	50,1	50,1	60	77	42	35	70	137	50	9	953	9022801	9300901

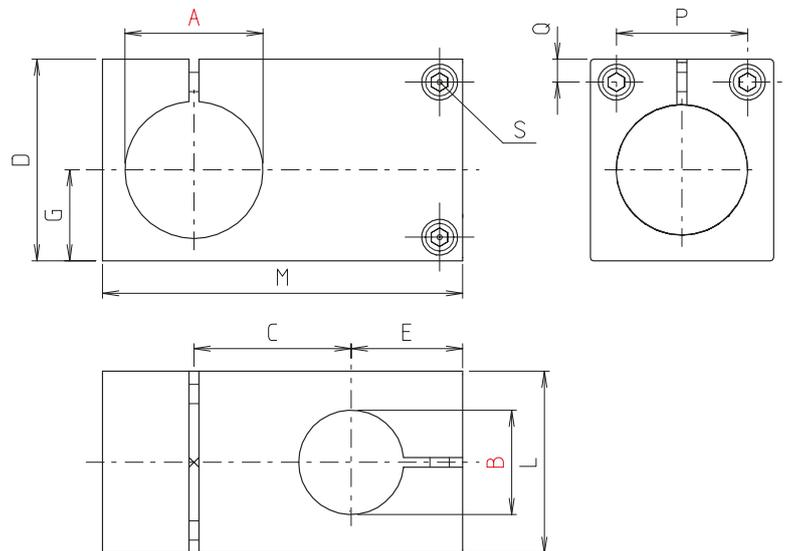

KD - Série quad®

[mm]

Code No.	Type	A	B	C	D	E	G	L	M	P	Q	m [g]	S	T
													Levier de serrage Code No.	
503020010300	KD 30x20	30,1	20,1	31	49	23	21	42	75	28	7	229	9301401	9300101
504030010300	KD 40x30	40,1	30,1	43	62	29	28	56	100	42	7	477	9301701	9301401
505040010300	KD 50x40	50,2	40,2	55	77	37	35	70	127	52	9	926	9022801	9300401

Solid Clamps – Raccords orthogonaux

Principe de commande:

- quad® avec vis en acier inoxydable
- Levier de serrage à commander séparément. Livré non monté. Voir dernière colonne du tableau et page 222

Sur demande:

- Anodisé noir

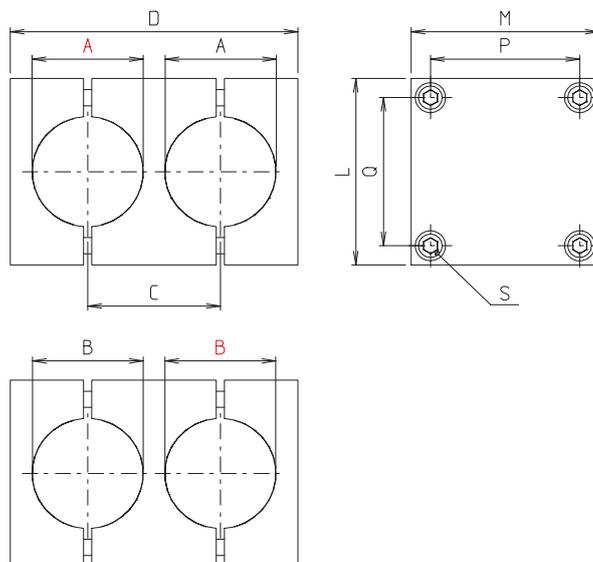

KRR - Série quad®

[mm]

Code No.	Type	A	B	C	D	L	M	P	Q	m [g]	Levier de serrage S Code No.
503000030300	KRR 30	30,1	30,1	36	78	56	56	42	42	346	9300101
504000030300	KRR 40	40,2	40,2	48	104	68	68	54	54	615	9301401
505000030300	KRR 50	50,3	50,3	60	130	85	85	67	67	1241	9300401
506000030300	KRR 60	60,3	60,3	72	169	105	105	85	85	–	9022801

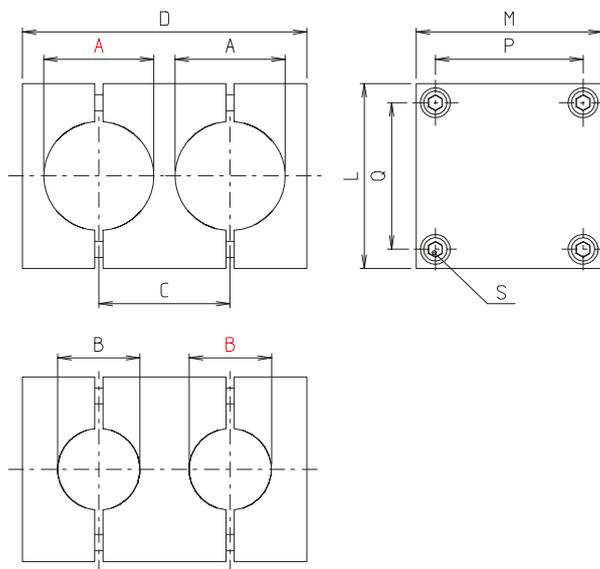

KRD - Série quad®

[mm]

Code No.	Type	A	B	C	D	L	M	P	Q	m [g]	Levier de serrage S Code No.
503020060300	KRD 30x20	30,1	20,1	36	78	56	56	42	42	414	9300101
504030060300	KRD 40x30	40,2	30,1	48	104	68	68	54	54	723	9301401
505040060300	KRD 50x40	50,3	40,2	60	130	85	85	67	67	1411	9300401
506050060300	KRD 60x50	60,3	50,4	72	169	105	105	85	85	–	9022801

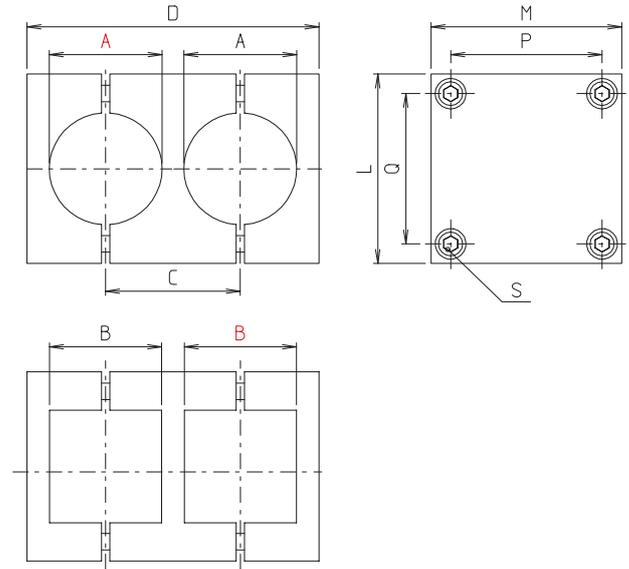
KVR - Série quad®

[mm]

Code No.	Type	A	B	C	D	L	M	P	Q	m [g]	Levier de serrage S Code No.
503000040300	KVR 30	30,1	30,2	36	78	56	56	42	42	301	9300101
504000040300	KVR 40	40,2	40,3	48	104	68	68	54	54	527	9301401
505000040300	KVR 50	50,3	50,4	60	130	85	85	67	67	1080	9300401
506000040300	KVR 60	60,3	60,4	72	169	105	105	85	85	–	9022801

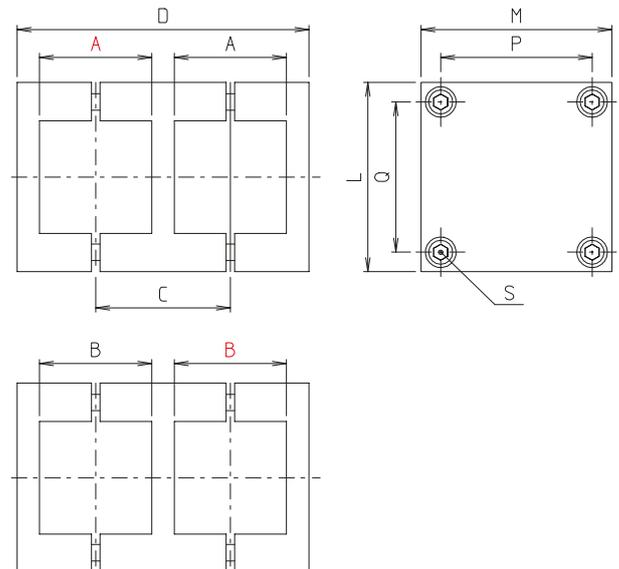
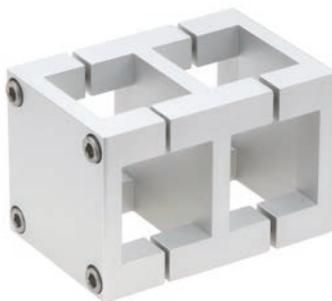
KV - Série quad®

[mm]

Code No.	Type	A	B	C	D	L	M	P	Q	m [g]	Levier de serrage S Code No.
503000050300	KV 30	30,2	30,2	36	78	56	56	42	42	277	9300101
504000050300	KV 40	40,3	40,3	48	104	68	68	54	54	477	9301401
505000050300	KV 50	50,4	50,4	60	130	85	85	67	67	961	9300401
506000050300	KV 60	60,4	60,4	72	169	105	105	85	85	–	9022801



Versions:

■ Raccords d'angle

Livrable
sur stock

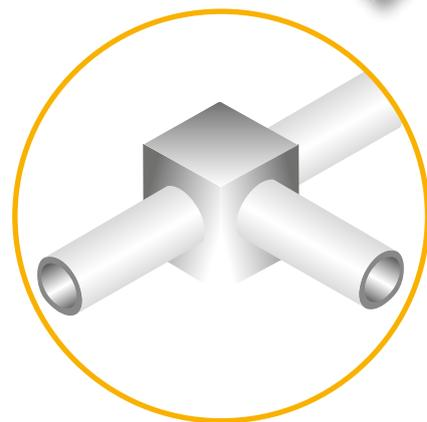

Éléments monoblocs

✓ Pour un montage plus rapide et économique



Série industrie

- Fonte d'aluminium
- Grande diversité
- Éléments monoblocs



Série quad®

- Profilé en aluminium extrudé
- Contrainte de couple maximale
- Surface anodisée haute qualité
- Éléments monoblocs et en plusieurs parties



Éléments en plusieurs parties

✓ Également conçus pour les montages et extensions a posteriori



Série quad®

- Profilé en aluminium extrudé
- Contrainte de couple maximale
- Surface anodisée haute qualité
- Éléments monoblocs et en plusieurs parties



Série bloc

- Fonte d'aluminium
- Contrainte de couple plus élevée
- Contours extérieurs plans
- Éléments en plusieurs parties

Charges admissibles

ATTENTION !

Les valeurs données dans les tableaux ne constituent pas un engagement sur les valeurs ni une garantie de résultat à propos de nos produits.

Il ne s'agit que de valeurs indicatives non contractuelles, qui peuvent dans certains cas ne pas être atteintes, dépendant notamment de divers facteurs liés aux applications, comme la température ou la nature de la surface des tubes.

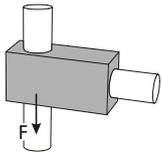

Adhérence F [KN]

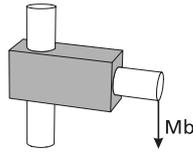

Moment de flexion Mb [Nm]

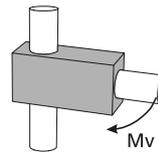

Couple de torsion Mv [Nm]

Couple de serrage des vis:

M6: 10 Nm

M8: 25 Nm

M10: 50 Nm

Talle Type	18			30			40			50			60			80		
	F	Mb	Mv	F	Mb	Mv	F	Mb	Mv	F	Mb	Mv	F	Mb	Mv	F	Mb	Mv
Série industrie																		
W	1,1	189	20	6,6	447	104	4,3	1365	104	12,1	900	217	10,7	1388	299			
WV				3,3	413	345	4,3	464	546									
WR				5,1	870	59	5,1	1174	158									
WE	2,5	52	14	6,6	494	41	6,6	300	300	10,6	409	217						
WVT				3,3	144	345	2,6	765	546									
WRT				5,1	141	63	5,1	1174	120									

Talle Type	18			30			40			50			60			80		
	F	Mb	Mv	F	Mb	Mv	F	Mb	Mv	F	Mb	Mv	F	Mb	Mv	F	Mb	Mv
Série bloc																		
WV				3,6	383	283	3,3	528	847	3	600	425	7,8	1197	917	11	3038	2400
WR				5,1	809	66	6,2	1560	44	9,8	1200	262	12,3	1500	255	19	950	601
WVT				3,6	149	283	3,3	793	847									
WRT				5,1	136	66	6,2	1560	44									
WK				4,9	594	41	4,9	1388	139	10	750	179	11,4	650	315			
WEV							1,2	493	844	5,9		678						
WER							0,7	883	37	8,7	1280	131						
WKR							6,1	1361	93	8,7	1250	272						
WERT							0,7	883	37	8,7	1280	131						
WEVT							1,2	686	844	5,9		678						

Talle Type	18			30			40			50			60			80		
	F	Mb	Mv	F	Mb	Mv	F	Mb	Mv	F	Mb	Mv	F	Mb	Mv	F	Mb	Mv
Série quad®																		
W	4	634	61	7,8	960	68	5,8	1788	159									
WR	5	1650	168	7,6	960	128	11,8	2200	272									
WRT	5,7	1475	166	7,6	960	128	11,8	2200	272									
WKR	5,7	1365	172	7,5	1050	510	11,8	2200	272									
WVR	6,1	618	70	8,4	1050	128	7,5	1800	1800									
WRV	6,2	1000	325	7,5	1200	46	7,5	2200	272									
WER	6,1	1139	49	2,7	1020	450	11,8	2200	272									
WV	5	410	534	8,1	1212	450	7,5	2022	1800	20,1								
WVT	5,1	411	524	6,3	1229	450	7,5	2022	1800	20,1								
WKV	5,7	781	350	8,1	1256	459	7,5	2022	1800									
WEV	4,5	527	350	2,8	897		7,5	2022	1800									

Solid Clamps – Raccords d'angle

Raccords tubulaires
perpendiculaires



Série industrie

Série bloc



Série quad®





Solid Clamps – Raccords d'angle

Principe de commande:

- Vis galvanisées en équipement standard
- Levier de serrage à commander séparément. Livré non monté. Voir dernière colonne du tableau et page 222

Sur demande:

- Vis en acier inoxydable
- En couleur
- Polissage à billes

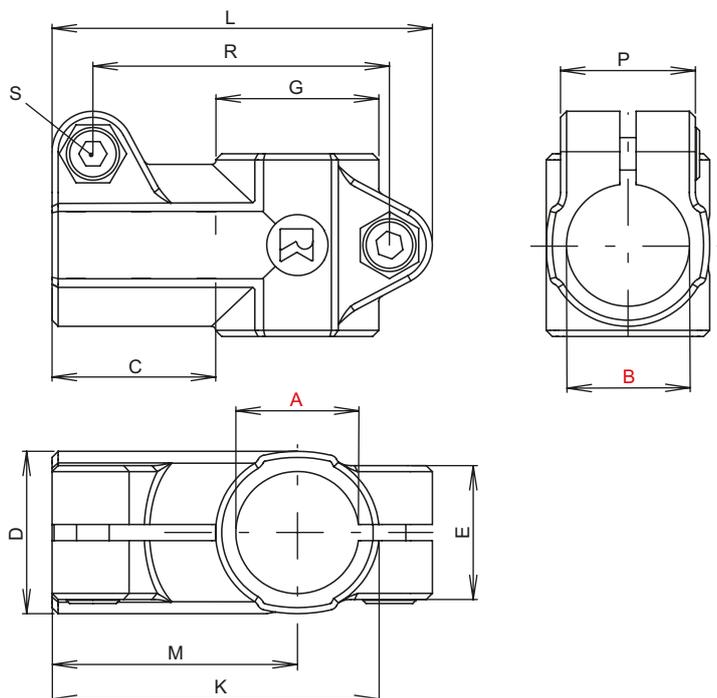

W - Série industrie

[mm]

Code No.	Type	A	B	C	D	E	G	K	L	M	P	R	m [g]	Levier de serrage S Code No.
111200000200	W 12	12,1	12,1	28	25	23	25	56	66	43	23	49	97	90209
111400000200	W 14	14,1	14,1										90	
111500000200	W 15	15,1	15,1										87	
111600000200	W 16	16,1	16,1										83	
111800000200	W 18	18,1	18,1										75	
112000000200	W 20	20,1	20,1	38	40	45	40	80	93	60	33	72,5	278	9022201
112500000200	W 25	25,1	25,1										240	
	W 28*	*Avec machon adaptateur R28, voir accessoires page 223												
113000000200	W 30	30,1	30,1	38	40	33	40	80	93	60	33	72,5	192	9022201
113200000200	W 32	32,2	32,2	55	56	40	56	117	134	88	40	108	680	90250
113500000200	W 35	35,15	35,15										623	
114000000200	W 40	40,15	40,15										530	
114800000200	W 48	48,22	48,22	63	66	45	66	131	149	98	45	123	759	90251
115000000200	W 50	50,22	50,22										705	
116000000200	W 60	60,27	60,27	78	80	58	80	160	183	120	58	151	1340	9025301
118000000200	W 80	80,35	80,35	121,7	110	123	110	231,7	259	176,8	82	214	3750	9027001

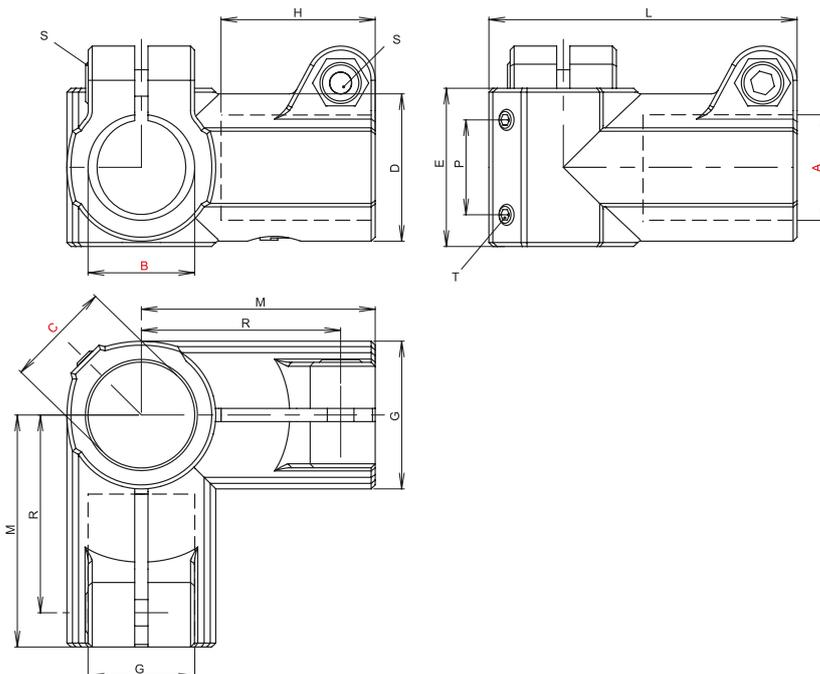

WE - Série industrielle

[mm]

Code No.	Type	A	B	C	D	E	G	H	L	M	R	T	m [g]	Levier de serrage S Code No.	
	WE28*			30	*Avec machon adaptateur R28, voir accessoires page 223										
1130000602005	WE 30	30,1	30,1	30	40	45	40	38	80	60	49	M8x15	250	9022201	
1140000602005	WE 40	40,15	40,15	40,15	56	60	56	58	116	88	70	M8x10	708	90250	
1145000602005	WE 45	45,2	45,2	45									1250	9024401	
1148000602005	WE 48	48,2	48,2	48									1113		
1150000602005	WE 50	50,22	50,22	50,22	66	70	66	70	136	108	90	M10x12	710	9025101	

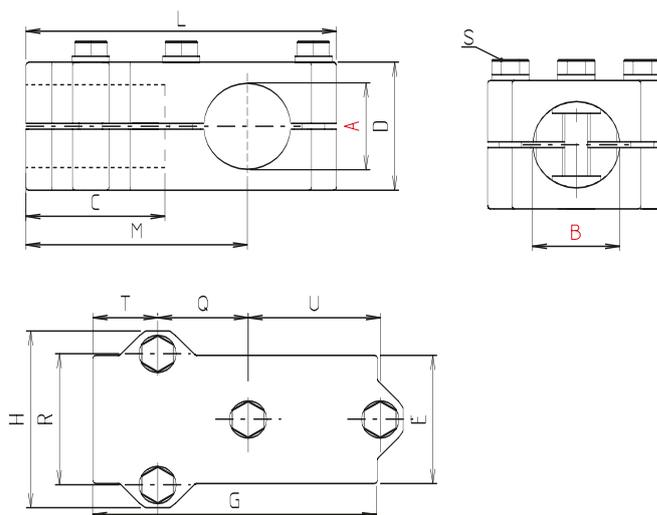

WR - Série industrielle

[mm]

Code No.	Type	A	B	C	D	E	G	H	L	M	Q	R	T	U	m [g]	Levier de serrage S Code No.
112500030200	WR 25	25,2	25,2	46	45	45	100	62	108	77	31,5	46	23	46	418	9022501
113000030200	WR 30	30,2	30,2		45	100	62	108	77	31,5	46	23	46	388		
113500030200	WR 35	35,2	35,2	60	60	60	129	75	136	99	40	57	30	57	770	9022801
114000030200	WR 40	40,2	40,2		60	129	75	136	99	40	57	30	57	738		

Solid Clamps – Raccords d'angle

Principe de commande:

- Vis galvanisées en équipement standard
- Levier de serrage à commander séparément. Livré non monté. Voir dernière colonne du tableau et page 222

Sur demande:

- Vis en acier inoxydable
- En couleur
- Polissage à billes

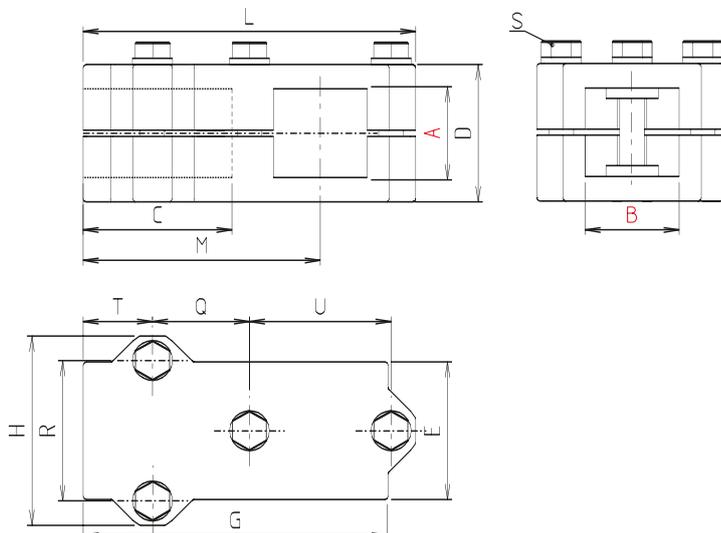

WV - Série industrie

[mm]

Code No.	Type	A	B	C	D	E	G	H	L	M	Q	R	T	U	m [g]	Levier de serrage S Code No.
112500050200	WV 25	25,3	25,3	46	45	45	100	62	108	77	31,5	46	23	46	389	9022501
113000050200	WV 30	30,3	30,3													
113500050200	WV 35	35,4	35,4	60	60	60	129	75	136	99	40	57	30	57	731	9022801
114000050200	WV 40	40,4	40,4													

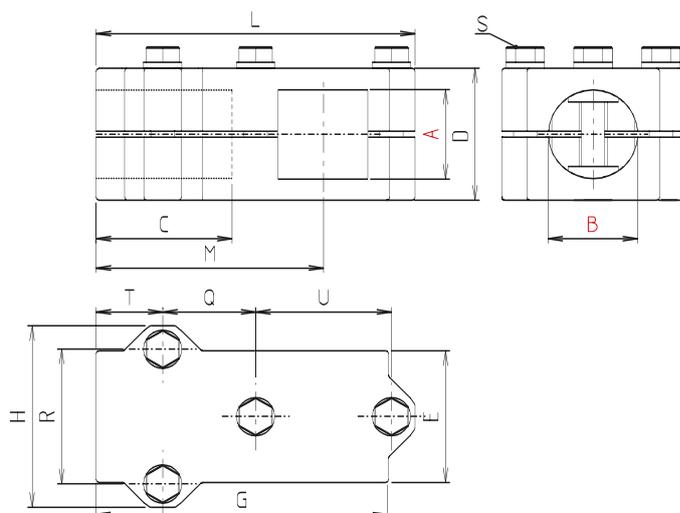

WVR - Série industrie

[mm]

Code No.	Type	A	B	C	D	E	G	H	L	M	Q	R	T	U	m [g]	Levier de serrage S Code No.
113000040200	WVR 30	30,3	30,2	46	45	45	100	62	108	77	31,5	46	23	46	358	9022501
114000040200	WVR 40	40,4	40,2	60	60	60	129	75	136	99	40	57	30	57	698	9022801

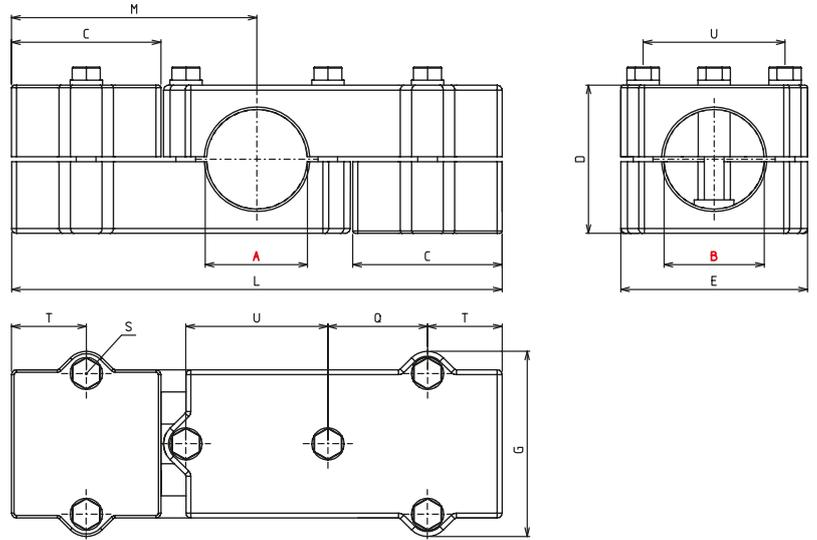

WRT - Série industrie

[mm]

Code No.	Type	A	B	C	D	E	G	L	M	Q	R	T	U	m [g]	Levier de serrage S Code No.
112500100200	WRT 25	25,2	25,2	46	45	45	62	154	77	31,5	46	23	46	621	9022501
113000100200	WRT 30	30,2	30,2											585	
113500100200	WRT 35	35,2	35,2	60	60	60	75	196	99	40	57	30	57	1148	9022801
114000100200	WRT 40	40,2	40,2											1104	

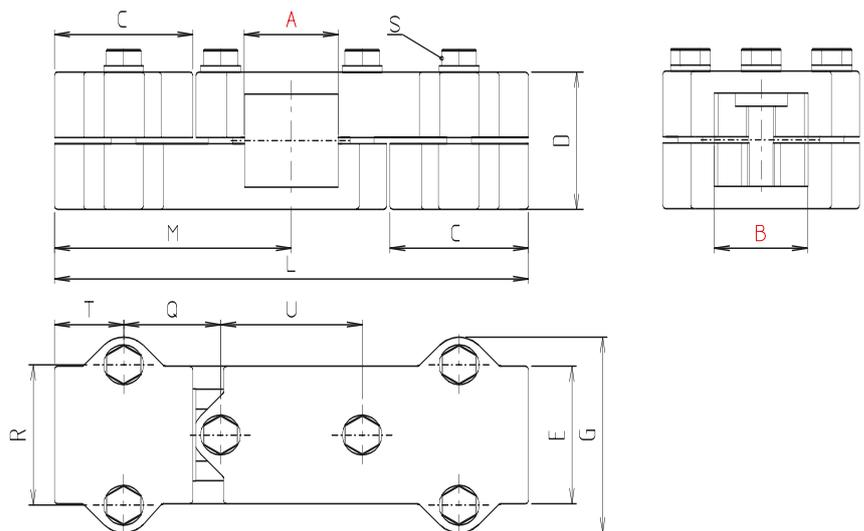

WWT - Série industrie

[mm]

Code No.	Type	A	B	C	D	E	G	L	M	Q	R	T	U	m [g]	Levier de serrage S Code No.
112500110200	WWT 25	25,3	25,3	46	45	45	62	154	77	31,5	46	22,5	46	601	9022501
113000110200	WWT 30	30,3	30,3											549	
113500110200	WWT 35	35,4	35,4	60	60	60	75	196	99	40	57	30	57	1084	9022801
114000110200	WWT 40	40,4	40,4											1044	

Solid Clamps – Raccords d'angle

Principe de commande:

- Vis galvanisées en équipement standard
- Levier de serrage à commander séparément. Livré non monté. Voir dernière colonne du tableau et page 222

Sur demande:

- Vis en acier inoxydable
- En couleur
- Polissage à billes

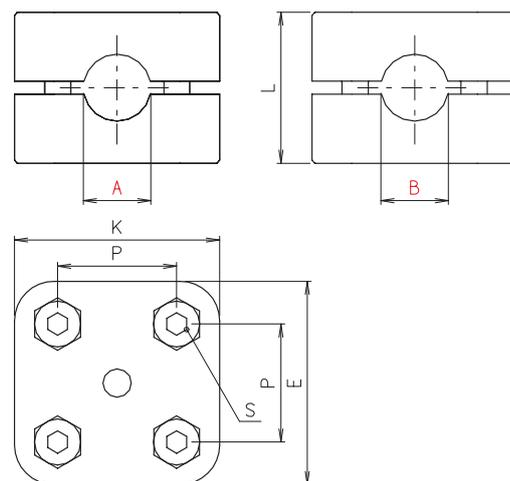

RRW - Série bloc

[mm]

Code No.	Type	A	B	E	K	L	P	S	m [g]
290800040266	RRW 8	8	8	31	31	23	18	M4x18	47
291000040266	RRW 10	10	10						46

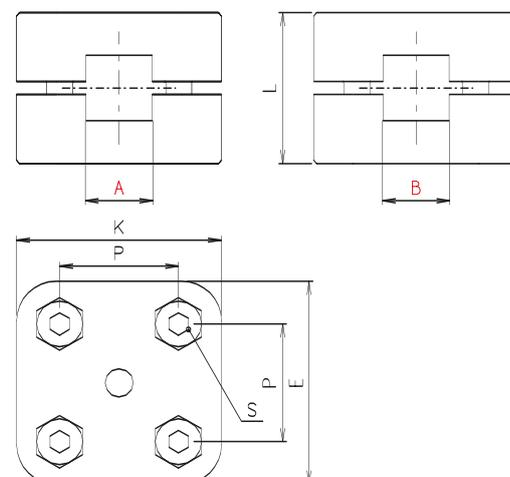

VVW - Série bloc

[mm]

Code No.	Type	A	B	E	K	L	P	S	m [g]
291000050266	VVW 10	10	10	31	31	23	18	M4x18	42

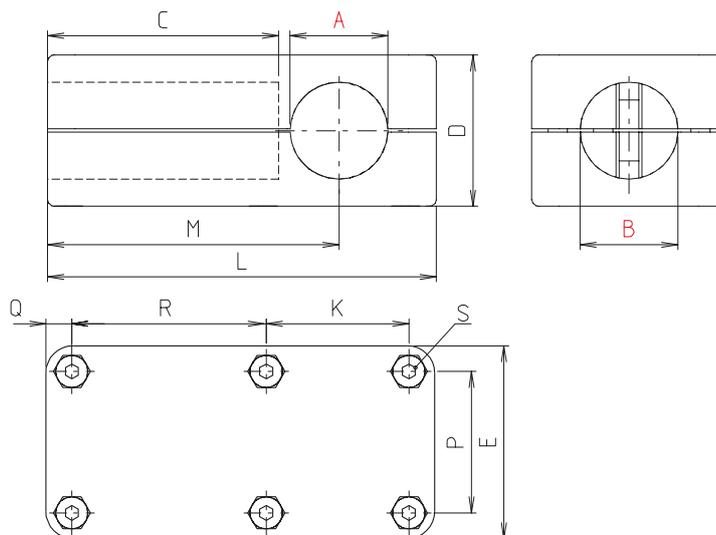

WR - Série bloc

[mm]

Code No.	Type	A	B	C	D	E	F	K	L	M	P	Q	R	m [g]	Levier de serrage S Code No.
213000030266	WR 30	30,2	30,2	60	48	60	16	44	120	90	44	8	44	499	9021401
213500030266	WR 35	35,3	35,3	70	62	70	17	53	140	105	53	9	55	782	9021601
214000030266	WR 40	40,2	40,2											750	
214200030266	WR 42	42,3	42,3	86	79	86	0	70	161	118	65	11	70	1579	9022901
214500030266	WR 45	45,3	45,3											1535	
214800030266	WR 48	48,3	48,3											1528	
215000030266	WR 50	50,3	50,3	100	90	100	0	84	190	140	78	11	84	2015	9023001
216000030266	WR 60	60,4	60,4											1490	
218000030266	WR 80	80,5	80,5	130	122	130	30	100	260	195	100	15	100	5030	9024601

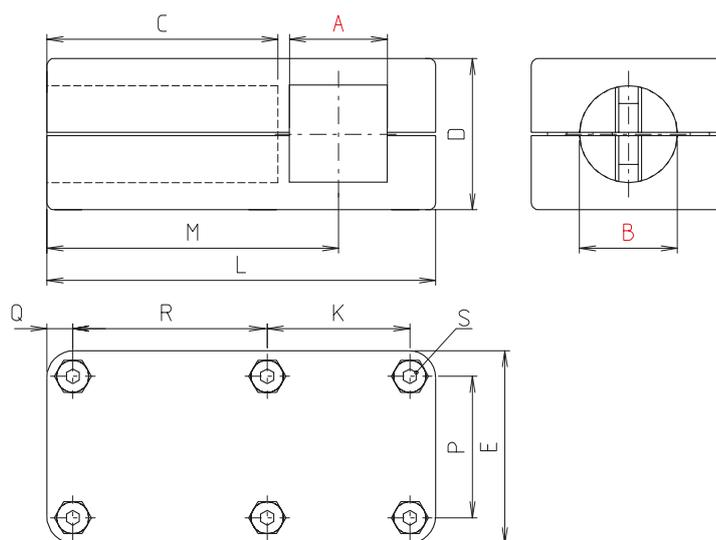

WVR - Série bloc

[mm]

Code No.	Type	A	B	C	D	E	K	L	M	P	Q	R	m [g]	Levier de serrage S Code No.
215000150266	WVR 50	50,3	50,3	86	79	86	70	161	118	65	11	70	1410	9022901
216000150266	WVR 60	60,4	60,4	100	90	100	84	190	140	78	11	84	1920	9023001

Solid Clamps – Raccords d'angle

Principe de commande:

- Vis galvanisées en équipement standard
- Levier de serrage à commander séparément. Livré non monté. Voir dernière colonne du tableau et page 222

Sur demande:

- Vis en acier inoxydable
- En couleur
- Polissage à billes

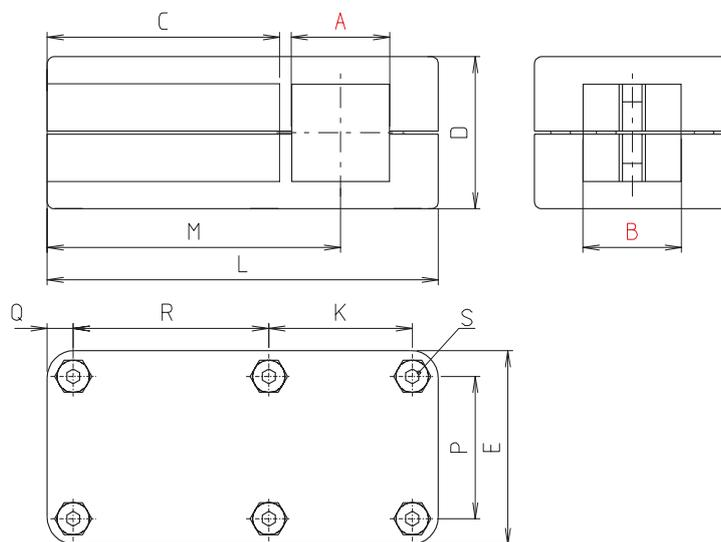

WV - Série bloc

[mm]

Code No.	Type	A	B	C	D	E	K	L	M	P	Q	R	m [g]	Levier de serrage S Code No.
213000050266	WV 30	30,3	30,3	60	48	60	44	120	90	44	8	60	482	9021401
213500050266	WV 35	35,4	35,4	70	62	70	53	140	105	53	9	70	765	9021601
214000050266	WV 40	40,4	40,4										716	
215000050266	WV 50	50,5	50,5	86	79	86	70	161	118	65	11	70	1406	9022901
216000050266	WV 60	60,6	60,6	100	90	100	84	190	140	78		84	1925	9023001
218000050266	WV 80	80,7	80,7	130	122	130	115	260	195	100	15	115	4680	9024601

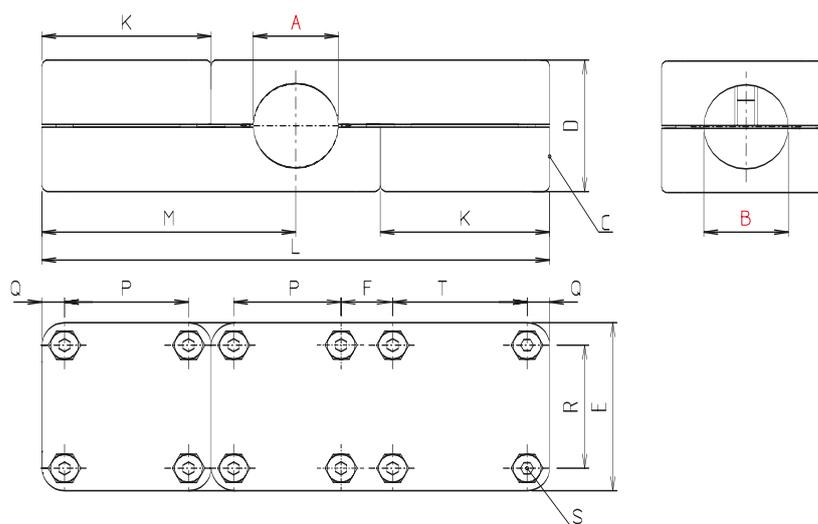

WRT - Série bloc

[mm]

Code No.	Type	A	B	C	D	E	F	K	L	M	P	Q	R	T	m [g]	Levier de serrage S Code No.
213000100266	WRT 30	30,2	30,2	30	48	60	15	60	180	90	44	8	44	44	753	9021401
214000100266	WRT 40	40,2	40,2	40	62	70	0	70	210	105	53	9	53	53	1151	9021601

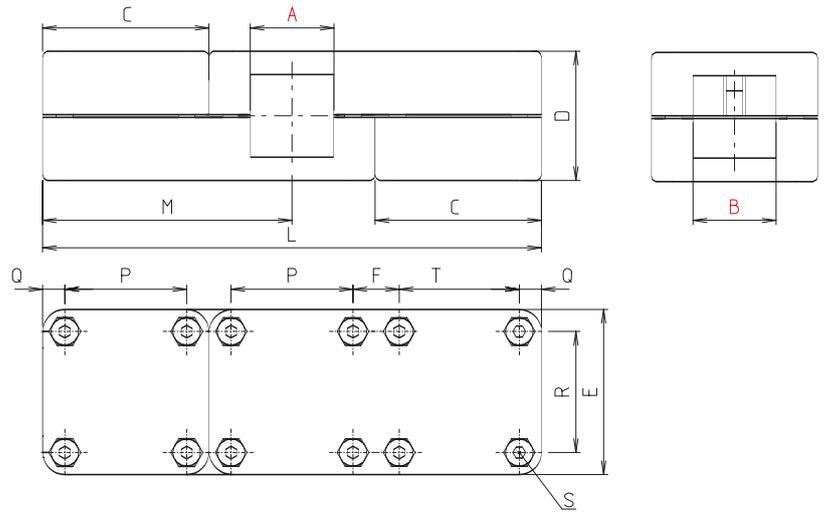

WVT - Série bloc

[mm]

Code No.	Type	A	B	C	D	E	F	L	M	P	Q	R	T	m [g]	Levier de serrage S Code No.
213000110266	WVT 30	30,3	30,3	60	48	60	15	180	90	44	8	44	44	732	9021401
214000110266	WVT 40	40,4	40,4	70	62	70	0	210	105	53	9	53	53	1080	9021601

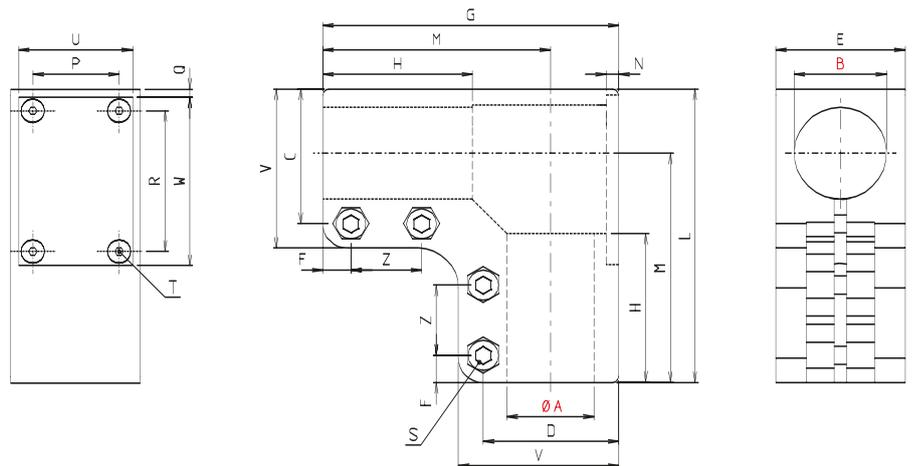

WK - Série bloc

[mm]

Code No.	Type	A	B	C	D	E	F	G	H	K	L	M	N	P	Q	R	T	U	V	W	Z	m [g]	Levier de serrage S Code No.
213000090266	WK 30	30,1	30,1	44	44	42	9	96	48	48	96	75	1	28		46	M4x6	37	52	55	32	449	9021301
214000090266	WK 40	40,2	40,2	70	70	54	12	128	65	65	128	100	2,5	38		61	M4x6	49	70	74	43	1008	9022501
214800090266	WK 48	48,2	48,2	70	70	65	12	148	75	75	148	115	2,5	49	2,5	71	M4x6	60	80	84	58	1533	9022701
215000090266	WK 50	50,2	50,2																			1474	9022801
216000090266	WK 60	60,3	60,3	80	80	80	25	170	110	110	170	130	4	-	-	-	-	-	80	-	0	2232	9024501

Solid Clamps – Raccords d'angle

Principe de commande:

- Vis galvanisées en équipement standard
- Levier de serrage à commander séparément. Livré non monté. Voir dernière colonne du tableau et page 222

Sur demande:

- Vis en acier inoxydable
- En couleur
- Polissage à billes

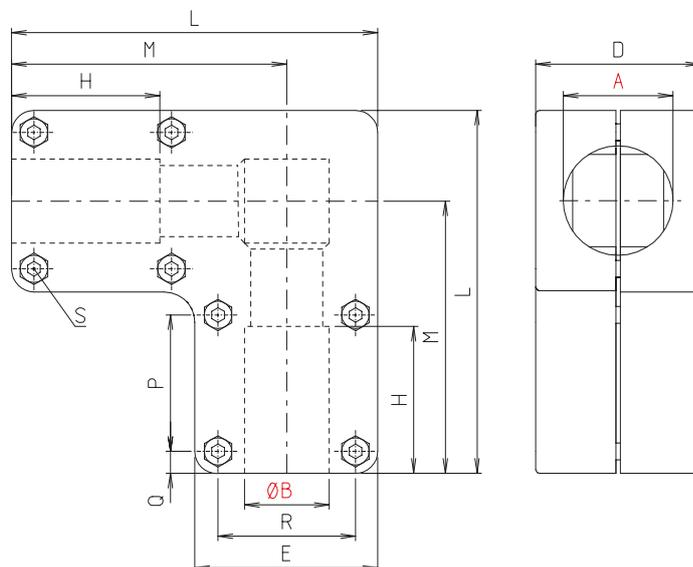

WKR - Série bloc

Code No.	Type	A	B	D	E	H	L	M	P	Q	R	m [g]	Levier de serrage S Code No.
213200010266	WKR 32	32,2	32,2	62	70	70	141	106	53	8,5	53	1667	9021601
213500010266	WKR 35	35,2	35,2									1328	
214000010266	WKR 40	40,2	40,2									1230	
214200010266	WKR 42	42,3	42,3	76	86	85	173	130	65	10,5	65	2639	9022901
214500010266	WKR 45	45,3	45,3									2642	
214800010266	WKR 48	48,3	48,3									2595	
215000010266	WKR 50	50,3	50,3									2380	

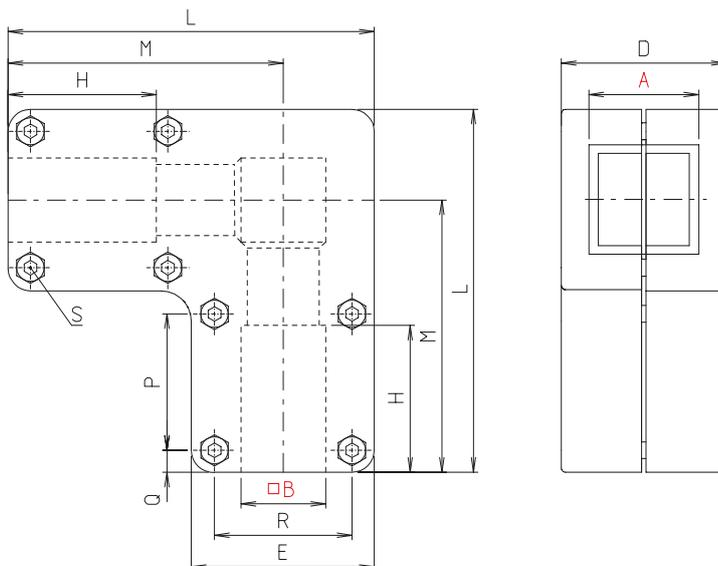

WKV - Série bloc

Code No.	Type	A	B	D	E	H	L	M	P	Q	R	m [g]	Levier de serrage S Code No.
213500020266	WKV 35	35,4	35,4	62	70	70	141	106	53	8,5	53	1258	9021601
214000020266	WKV 40	40,4	40,4									1192	
215000020266	WKV 50	50,5	50,5	76	86	95	173	130	65	10,5	65	2320	9022901

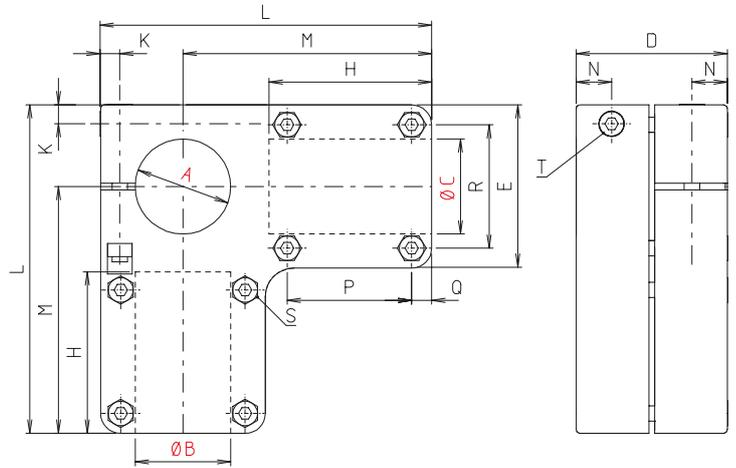

WER - Série bloc

[mm]

Code No.	Type	A	B	C	D	E	H	K	L	M	N	P	Q	R	m [g]	Levier de serrage Code No.	
																S	T
2132000702666	WER 32	32,2	32,2	32											1448		
2135000702666	WER 35	35,2	35,2	35	62	70	70	9	141	106	16	53	8,5	53	1340	9021601	9021601
2140000702666	WER 40	40,2	40,2	40											1275		
2145000702666	WER 45	45,2	45,3	45											2698		
2148000702666	WER 48	48,2	48,3	48	76	86	85	10	173	130	19	65	11	65	2644	9022901	9022901
2150000702666	WER 50	50,2	50,3	50											2520		

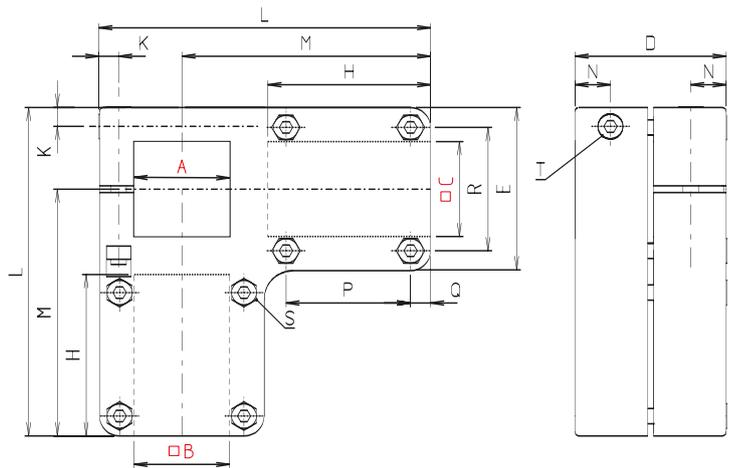

WEV - Série bloc

[mm]

Code No.	Type	A	B	C	D	E	H	L	M	P	Q	R	m [g]	Levier de serrage Code No.	
														S	T
2135000802666	WEV 35	35,4	35,4	35	62	70	70	141	106	53	9	53	1286	9021601	9021601
2140000802666	WEV 40	40,4	40,4	40									1205		
2150000802666	WEV 50	50,5	50,5	51	76	86	85	173	130	65	11	65	2320	9022901	9022901

Solid Clamps – Raccords d'angle

Principe de commande:

- Vis galvanisées en équipement standard
- Levier de serrage à commander séparément. Livré non monté. Voir dernière colonne du tableau et page 222

Sur demande:

- Vis en acier inoxydable
- En couleur
- Polissage à billes

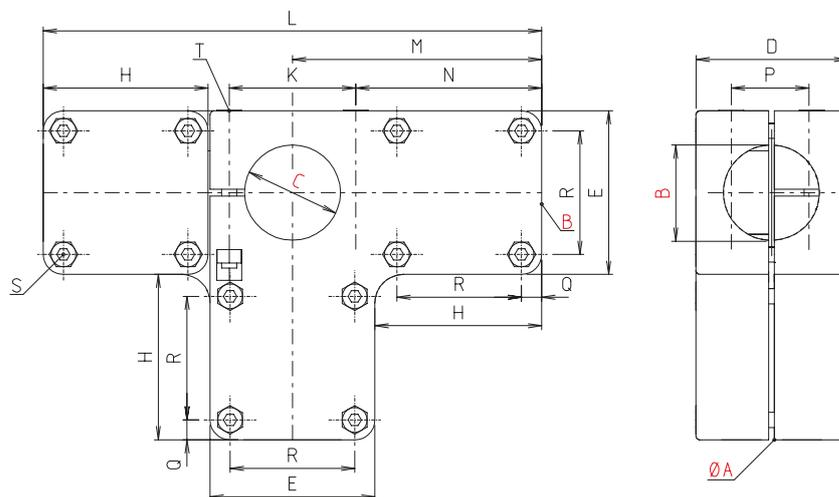

WERT - Série bloc

Code No.	Type	A	B	C	D	E	H	K	L	M	N	P	Q	R	m [g]	Levier de serrage S Code No.
2132001202666	WERT 32	32,2	32,2	32											1864	9021601
2135001202666	WERT 35	35,2	35,2	35	62	70	70	53	212	106	80	33,5	8,5	53	1738	
2140001202666	WERT 40	40,2	40,2	40											1678	
2145001202666	WERT 45	45,3	45,3	45											3580	9022901
2148001202666	WERT 48	48,3	48,3	48	76	86	86	66	260	130	97	41	10,5	65	3512	
2150001202666	WERT 50	50,3	50,3	50											3360	

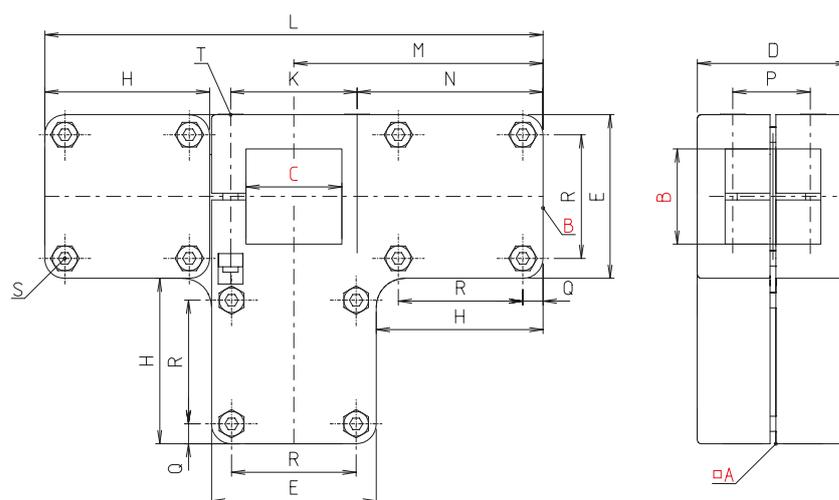

WEVT - Série bloc

Code No.	Type	A	B	C	D	E	H	K	L	M	N	P	Q	R	m [g]	Levier de serrage S Code No.
2135001302666	WEVT 35	35,4	35,4	35	62	70	70	53	212	106	80	33,5	8,5	53	1673	9021601
2140001302666	WEVT 40	40,4	40,4	40											1573	
2150001302666	WEVT 50	50,5	50,5	51	76	86	95	66	260	130	97	41	10,5	65	3100	



Solid Clamps – Raccords d'angle

Principe de commande:

- Vis galvanisées en équipement standard
- Levier de serrage à commander séparément. Livré non monté. Voir dernière colonne du tableau et page 222

Sur demande:

- Anodisé noirs

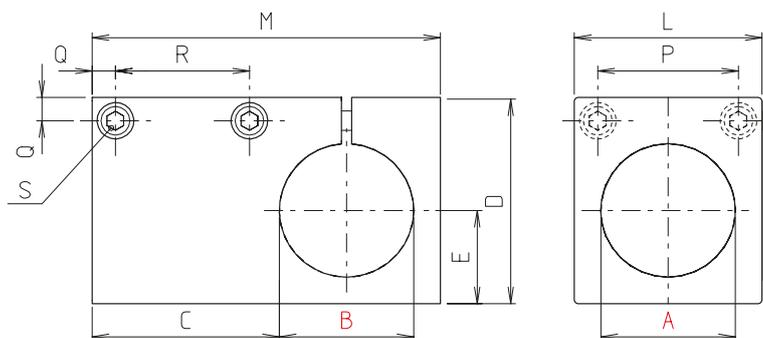

W - Série quad®

[mm]

Code No.	Type	A	B	C	D	E	L	M	P	Q	R	m [g]	Levier de serrage S Code No.
51300000300	W 30	30,1	30,1	42	49	21	42	78	28	7	26	251	9300101
51400000300	W 40	40,1	40,1	56	62	28	56	104	42	7	40	544	9301401
51500000300	W 50	50,2	50,2	70	77	35	70	130	50	9	50	1049	9300401

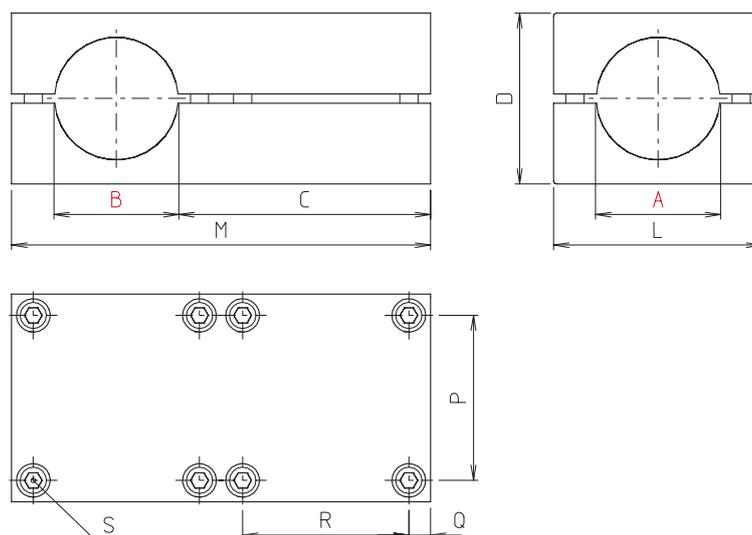

WR - Série quad®

[mm]

Code No.	Type	A	B	C	D	L	M	P	Q	R	m [g]	Levier de serrage S Code No.
513000030300	WR 30	30,1	30,1	69	42	56	112	42	7	42	450	9300101
514000030300	WR 40	40,2	40,2	82	56	68	136	54	7	54	812	9301401
515000030300	WR 50	50,3	50,3	102	70	85	170	67	9	67	1633	9300401
516000030300	WR 60	60,3	60,3	127	97	105	210	85	10	85	-	9022801

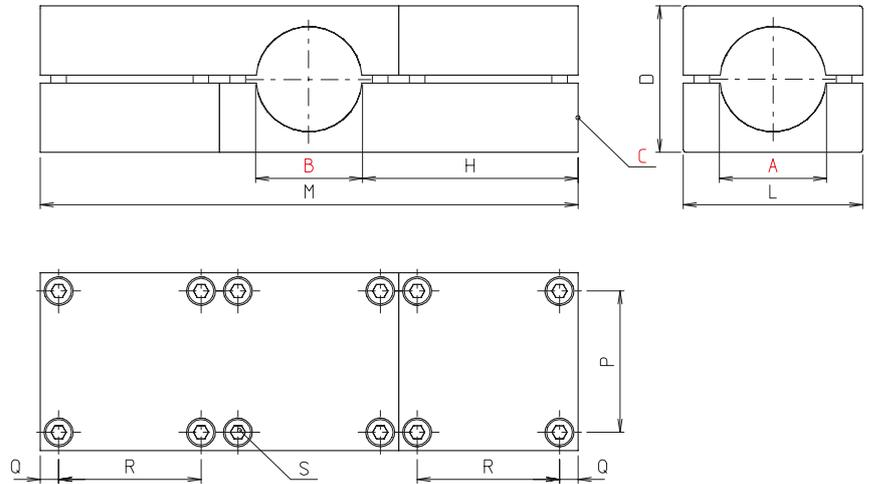

WRT - Série quad®

[mm]

Code No.	Type	A	B	C	D	H	L	M	P	Q	R	m [g]	Levier de serrage S Code No.
513000100300	WRT 30	30,1	30,1	30,1	42	69	56	168	42	7	42	702	9300101
514000100300	WRT 40	40,2	40,2	40,2	56	82	68	204	54	7	54	1257	9301401
515000100300	WRT 50	50,3	50,3	50,3	70	102	85	255	67	9	67	2563	9300401

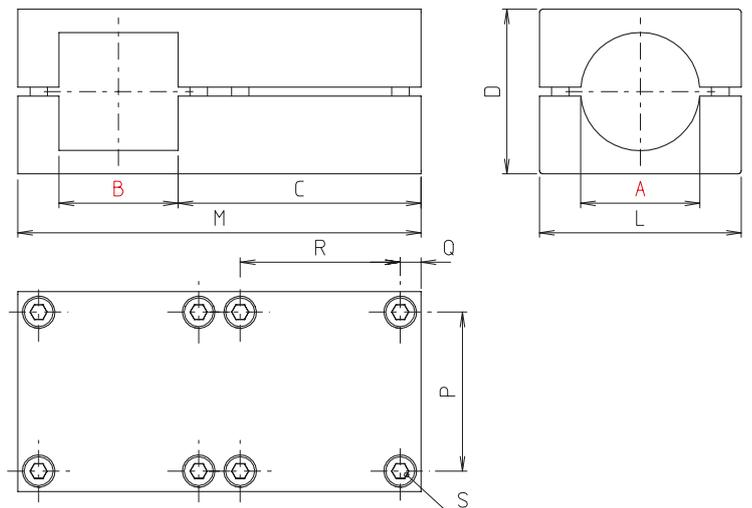

WVR - Série quad®

[mm]

Code No.	Type	A	B	C	D	L	M	P	Q	R	m [g]	Levier de serrage S Code No.
513000150300	WVR 30	30,2	30,1	69	42	56	112	42	7	42	430	9300101
514000150300	WVR 40	40,3	40,2	82	56	68	136	54	7	54	772	9301401
515000150300	WVR 50	50,4	50,3	102	70	85	170	67	9	67	1580	9300401
516000150300	WVR 60	60,3	60,4	127	97	105	210	85	10	85	-	9022801

Solid Clamps – Raccords d'angle

Principe de commande:

- Vis galvanisées en équipement standard
- Levier de serrage à commander séparément. Livré non monté. Voir dernière colonne du tableau et page 222

Sur demande:

- Anodisé noirs

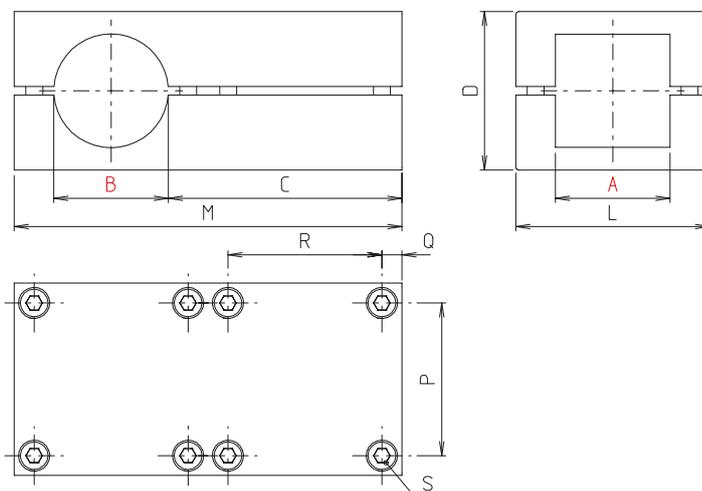

WRV - Série quad®

Code No.	Type	A	B	C	D	L	M	P	Q	R	m [g]	Levier de serrage S Code No.
513000140300	WRV 30	30,1	30,2	69	42	56	112	42	7	42	400	9300101
514000140300	WRV 40	40,2	40,3	82	56	68	136	54	7	54	702	9301401
515000140300	WRV 50	50,3	50,4	102	70	85	170	67	9	67	1412	9300401
516000140300	WRV 60	60,3	60,3	127	97	105	210	85	10	85	–	9022801

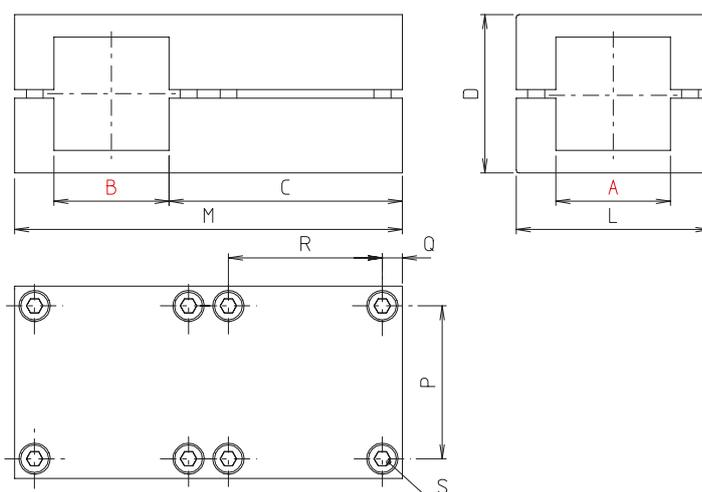

WV - Série quad®

Code No.	Type	A	B	C	D	L	M	P	Q	R	m [g]	Levier de serrage S Code No.
513000050300	WV 30	30,2	30,2	69	42	56	112	42	7	42	387	9300101
514000050300	WV 40	40,3	40,3	82	56	68	136	54	7	54	693	9301401
515000050300	WV 50	50,4	50,4	102	70	85	170	67	9	67	1370	9300401
516000050300	WV 60	60,4	60,4	127	97	105	210	85	10	85	–	9022801
518000050300	WV 80	80,4	80,4	149	112	126	252	100	13	100	4200	9300801

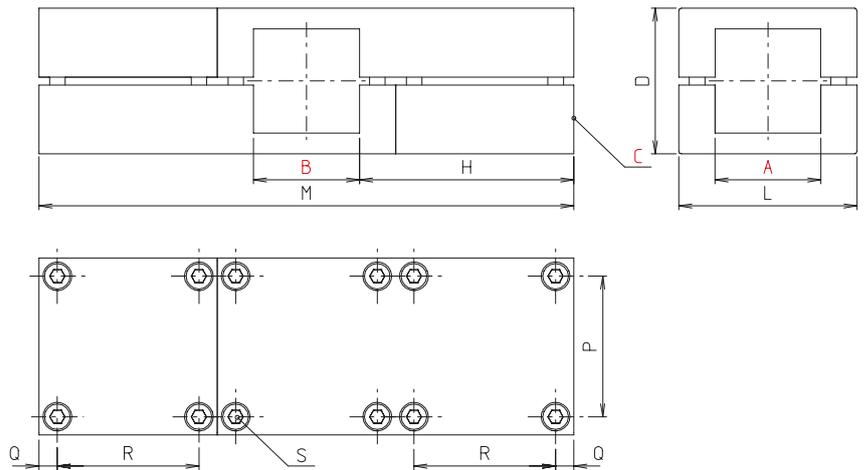
WVT - Série quad®

[mm]

Code No.	Type	A	B	C	D	H	L	M	P	Q	R	m [g]	Levier de serrage S Code No.
5130001103000	WVT 30	30,2	30,2	30,2	42	69	56	168	42	7	42	667	9300101
5140001103000	WVT 40	40,3	40,3	40,3	56	82	68	204	54	7	54	1168	9301401
5150001103000	WVT 50	50,4	50,4	50,4	70	102	85	255	67	9	67	2155	9300401
5180001103000	WVT 80	80,4	80,4	80,4	112	159	126	378	100	13	100	6782	9300801

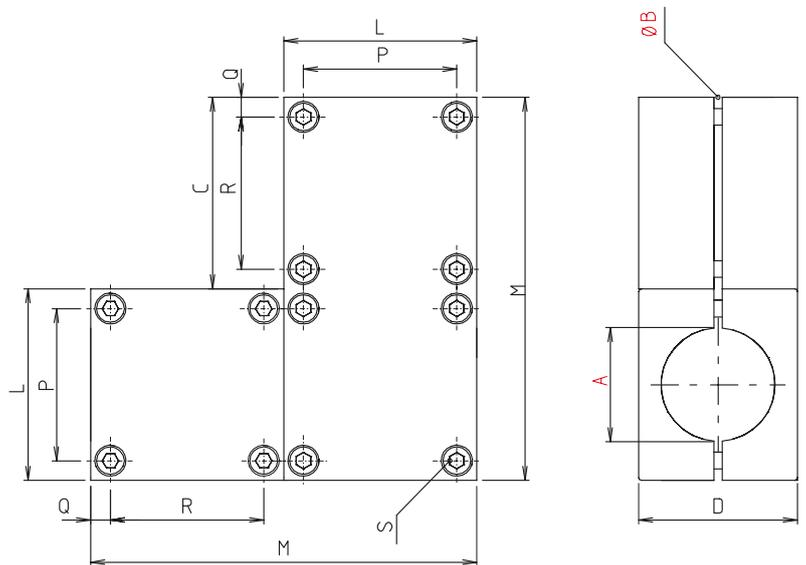
WKR - Série quad®

[mm]

Code No.	Type	A	B	C	D	L	M	P	Q	R	m [g]	Levier de serrage S Code No.
513000010300	WKR 30	30,1	30,1	56	42	56	112	42	7	42	702	9300101
514000010300	WKR 40	40,2	40,2	68	56	68	136	54	7	54	1257	9301401
515000010300	WKR 50	50,3	50,3	85	70	85	170	67	9	67	2563	9300401

Solid Clamps – Raccords d'angle

Principe de commande:

- Vis galvanisées en équipement standard
- Levier de serrage à commander séparément. Livré non monté. Voir dernière colonne du tableau et page 222

Sur demande:

- Anodisé noirs

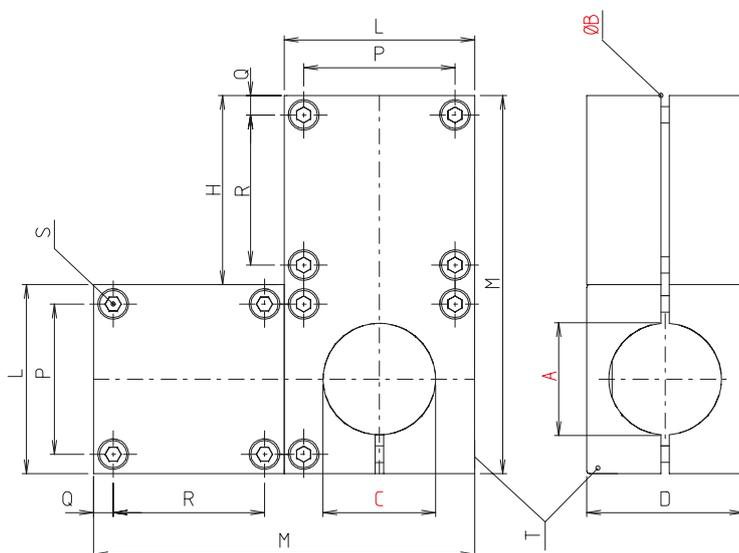

WER - Série quad®

[mm]

Code No.	Type	A	B	C	D	H	L	M	P	Q	R	m [g]	S	T
													Levier de serrage Code No.	
5130000703000	WER 30	30,1	30,1	30,1	42	56	56	112	42	7	42	725	9300101	9300101
5140000703000	WER 40	40,2	40,2	40,2	56	68	68	136	54	7	54	1311	9301401	9301401
5150000703000	WER 50	50,3	50,3	50,3	70	85	85	170	67	9	67	2627	9300401	9300401

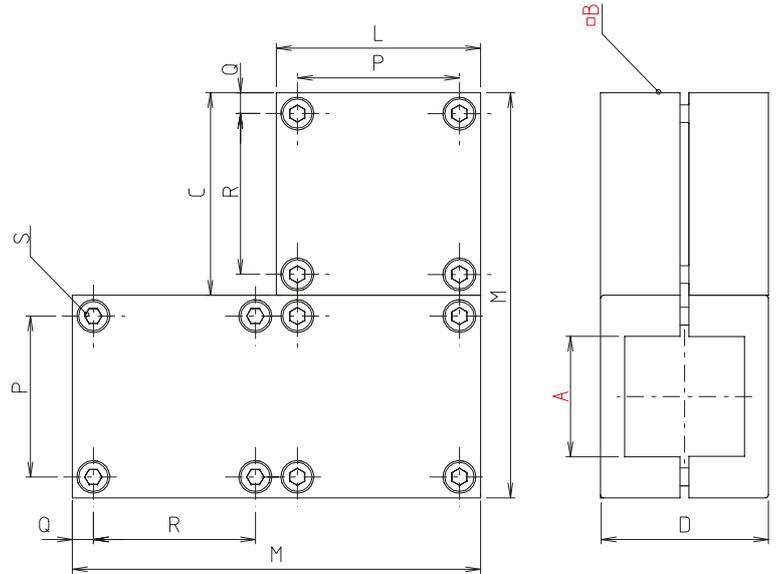
WKV - Série quad®

[mm]

Code No.	Type	A	B	C	D	L	M	P	Q	R	m [g]	Levier de serrage S Code No.
513000020300	WKV 30	30,2	30,2	56	42	56	112	42	7	42	634	9300101
514000020300	WKV 40	40,3	40,3	68	56	68	136	54	7	54	1133	9301401
515000020300	WKV 50	50,4	50,4	85	70	85	170	67	9	67	2274	9300401

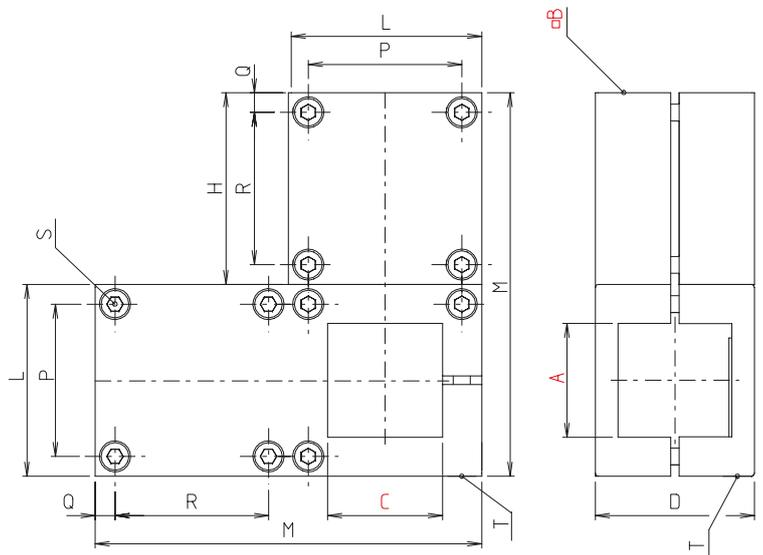
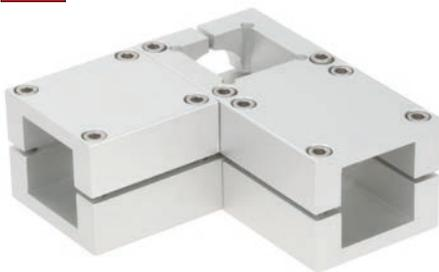
WEV - Série quad®

[mm]

Code No.	Type	A	B	C	D	H	L	M	P	Q	R	m [g]	S	T
													Levier de serrage Code No.	
5130000803000	WEV 30	30,2	30,2	30,2	42	56	56	112	42	7	42	634	9300101	9300101
5140000803000	WEV 40	40,3	40,3	40,3	56	68	68	136	54	7	54	1133	9301401	9301401
5150000803000	WEV 50	50,4	50,4	50,4	70	85	85	170	67	9	67	2274	9300401	9300401



Versions:

■ Pieds

Livrable
sur stock



Éléments monoblocs

✓ Pour un montage plus rapide et économique



Série industrie

- Fonte d'aluminium
- Grande diversité
- Éléments monoblocs



Série quad®

- Profilé en aluminium extrudé
- Contrainte de couple maximale
- Surface anodisée haute qualité
- Éléments monoblocs et en plusieurs parties



Éléments en plusieurs parties

✓ Également conçus pour les montages et extensions a posteriori



Série quad®

- Profilé en aluminium extrudé
- Contrainte de couple maximale
- Surface anodisée haute qualité
- Éléments monoblocs et en plusieurs parties



Série bloc

- Fonte d'aluminium
- Contrainte de couple plus élevée Ebene
- Contours extérieurs plans
- Éléments en plusieurs parties

Charges admissibles

ATTENTION !

Les valeurs données dans les tableaux ne constituent pas un engagement sur les valeurs ni une garantie de résultat à propos de nos produits.

Il ne s'agit que de valeurs indicatives non contractuelles, qui peuvent dans certains cas ne pas être atteintes, dépendant notamment de divers facteurs liés aux applications, comme la température ou la nature de la surface des tubes.

Couple de serrage des vis:

M6: 10 Nm

M8: 25 Nm

M10: 50 Nm

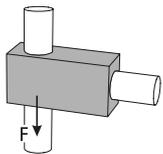

Adhérence F [KN]

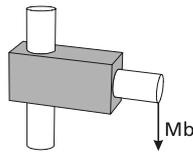

Moment de flexion Mb [Nm]

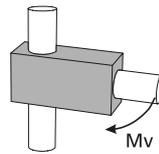

Couple de torsion Mv [Nm]

Pour obtenir ces valeurs, il faut utiliser des rondelles avec les vis de fixation des embases

Taille Type	18			30			40			50			60			80		
	F	Mb	Mv	F	Mb	Mv	F	Mb	Mv	F	Mb	Mv	F	Mb	Mv	F	Mb	Mv
Série industrie																		
FS				5,7	302	87	7,5	418	121	8,7	1375	150	16	1250	374			
FR							4,5	738	96	5,4	1395	207						
FV				5,6	125	296	2,9	290	623									
FRR				6,7	555	108	5,9	743	91									
FRA										5	600	250	12	1297	256			
FVA										5,9	1015	726	8	1750	1155			
FRAA										7,7	971	257	12	1750	263			

Taille Type	18			30			40			50			60			80		
	F	Mb	Mv	F	Mb	Mv	F	Mb	Mv	F	Mb	Mv	F	Mb	Mv	F	Mb	Mv
Série bloc																		
FV				3,0	441	213	3,1	811	855	5,9	600	726				18	2125	2250
FRR				4,5	433	80	5,7	838	58	7,7	600	257				10	2250	692

Taille Type	18			30			40			50			60			80		
	F	Mb	Mv	F	Mb	Mv	F	Mb	Mv	F	Mb	Mv	F	Mb	Mv	F	Mb	Mv
Série quad®																		
FS	2,1	418	39	3,9	703	81	5,8	1960	118									
FR	5,6	548	65	7,4	744	121	11,5	1960	272	21,5		950						
FV	3,2	541	338	7,1	881	540	7,5	1960	50	20,1								

Solid Clamps – Pieds

Raccords tubulaires
perpendiculaires



Série industrie



Série bloc



Série quad®





FS-B p. 97



FR p. 98



FVV-S p. 98



FVV-D p. 99



FP p. 102



FP FS p. 102



FP FRR p. 102



FP FV p. 103



FV p. 105



FRR p. 106

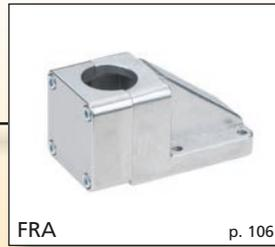

FRA p. 106



FVA p. 107



FPU p. 108



BAK-80 p. 109

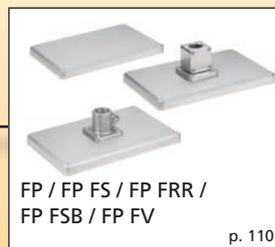

FP / FP FS / FP FRR /
FP FSB / FP FV p. 110



FV p. 113



FRS p. 113

Solid Clamps – Pieds

Principe de commande:

- Vis galvanisées en équipement standard
- Levier de serrage à commander séparément. Livré non monté. Voir dernière colonne du tableau et page 222

Sur demande:

- Vis en acier inoxydable
- En couleur
- Polissage à billes

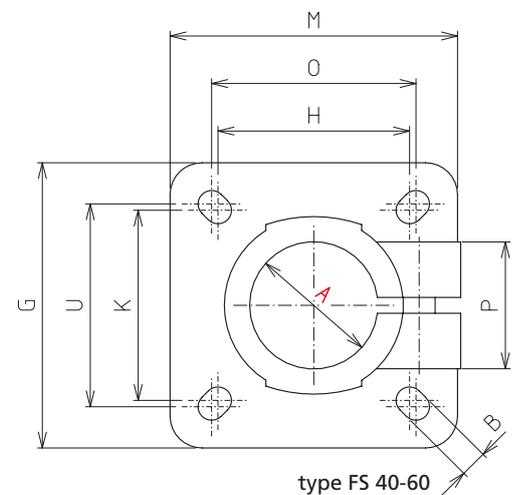
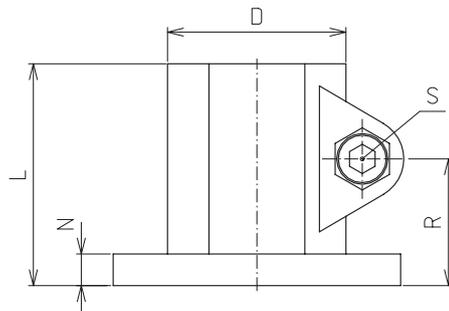
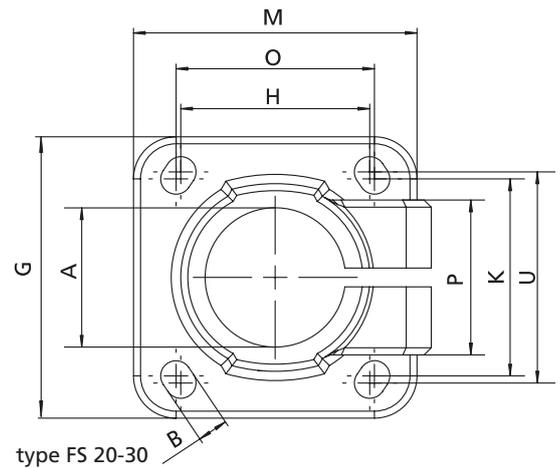

FS - Série industrie

Code No.	Type	A	B	D	G	H	K	L	M	N	O	P	R	U	m [g]	Levier de serrage S Code No.
13120000020	FS 12	12,1													65	90209
13140000020	FS 14	14,1												61		
13150000020	FS 15	15,1	6	25	42	28	28	37	42	5	30	23	21	30	58	
13160000020	FS 16	16,1													57	
13180000020	FS 18	18,1													52	
13200000020	FS 20	20,1													186	
13250000020	FS 25	25,1	7	40	60	40	42	50	60	8	42	33	29	45	164	
	FS 28*	*Avec machon adaptateur R28, voir accessoires page 223														
13300000020	FS 30	30,1	7	40	60	40	42	50	60	8	42	33	29	45	137	9022201
13320000020	FS 32	32,17													465	90250
13300200020	FS 30(32)	30,1													465	
13350000020	FS 35	35,17	9	56	90	60	60	70	90	10	64	40	40	64	450	
13400000020	FS 40	40,17													385	90251
13400200020	FS 40(42)	40,17													758	
13420000020	FS 42	42,22													720	
13480000020	FS 48	48,22	11	66	105	74	74	85	105	14	80	45	49,5	80	636	
13500000020	FS 50	50,22													603	
13600000020	FS 60	60,27	11	80	120	80	80	100	120	15	89	58	57,5	89	935	9025301
13800000020	FS 80**	80,35	17,5	110	170	120	120	141,4	174,5	22	-	82	119	-	2770	9027001

**type FS 80 avec trou arrondie

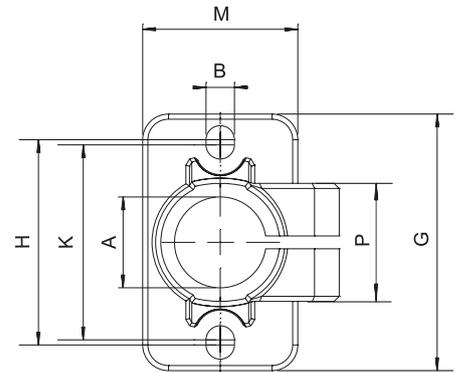
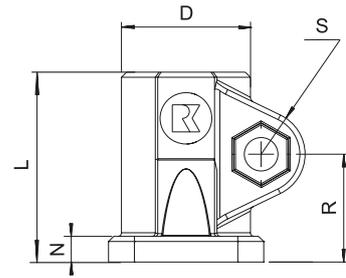

[mm]



FS 2 - Série industrie

Code No.	Type	A	B	D	G	H	K	L	M	N	P	R	m [g]	Levier de serrage S Code No.
13120300020	FS 12-2	12,1	5,5	25	50	40	38	37	30	5	23	21	65	90209
13140300020	FS 14-2	14,1											61	
13150300020	FS 15-2	15,1											58	
13160300020	FS 16-2	16,1											57	
13180300020	FS 18-2	18,1											52	



FS-B - Série industrie

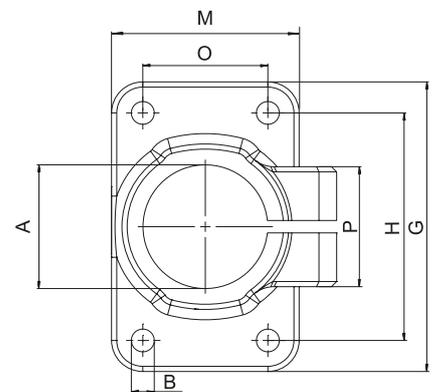
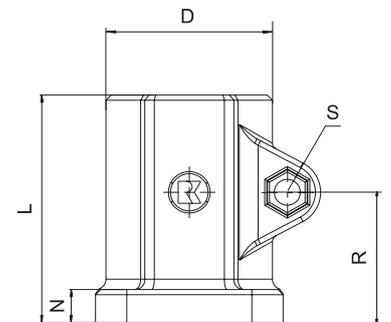

[mm]

Code No.	Type	A	B	D	G	H	L	M	N	O	P	R	m [g]	Levier de serrage S Code No.
13600200020	FS-B 60	60,27	11	80	140	110	110	90	16	60	58	63	920	9025301

Solid Clamps – Pieds

Principe de commande:

- Vis galvanisées en équipement standard
- Levier de serrage à commander séparément. Livré non monté. Voir dernière colonne du tableau et page 222

Sur demande:

- Vis en acier inoxydable
- En couleur
- Polissage à billes

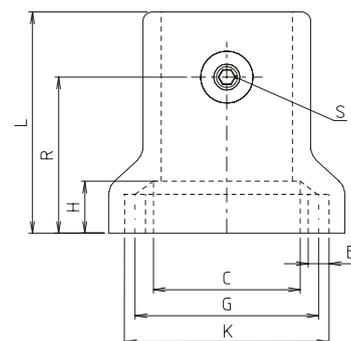
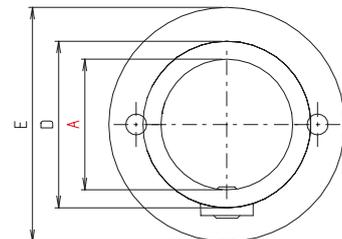

FR - Série industrie

[mm]

Code No.	Type	A	B	C	D	E	G	H	K	L	R	m [g]	Levier de serrage S Code No.
13400009020	FR 40	40,2	M8	56	64	90	69	20	77	85	60	474	9024101
13420009020	FR 42	42,2										458	9024301
13450009020	FR 45	45,2										407	9024101
13480009020	FR 48	48,2										383	9024301
13500009020	FR 50	50,2										359	9024101

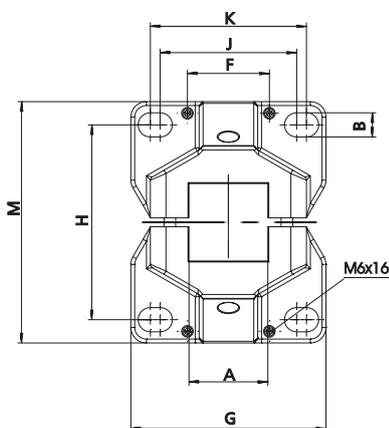
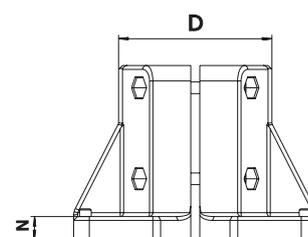
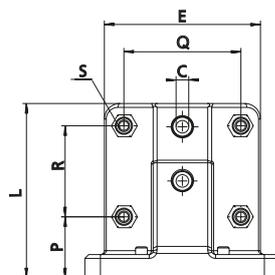

FVV-S - Série industrie

[mm]

Code No.	Type	A	B	C	D	E	F	G	H	J	K	L	M	N	P	Q	R	S	m [g]
4014312	FVV-S 40	40,4	12,5	7	79	80	42	100	100	70	80	90	125	12	31,5	60	47	M6x45	805

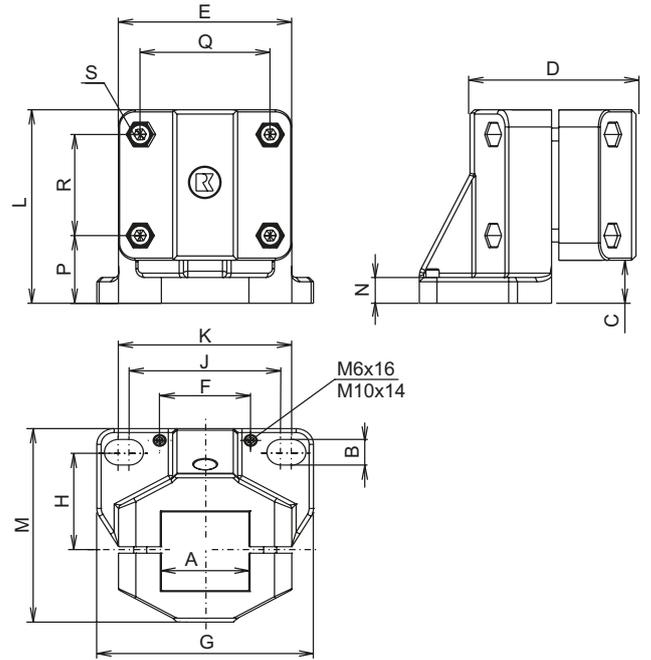

FVV-D - Série industrie

[mm]

Code No.	Type	A	B	C	D	E	F	G	H	J	K	L	M	N	P	Q	R	S	m [g]
4014313	FVV-D 40	40,4	12,5	20	75	80	42	100	50	70	80	90	98	12	31,5	60	47	M6x45	633

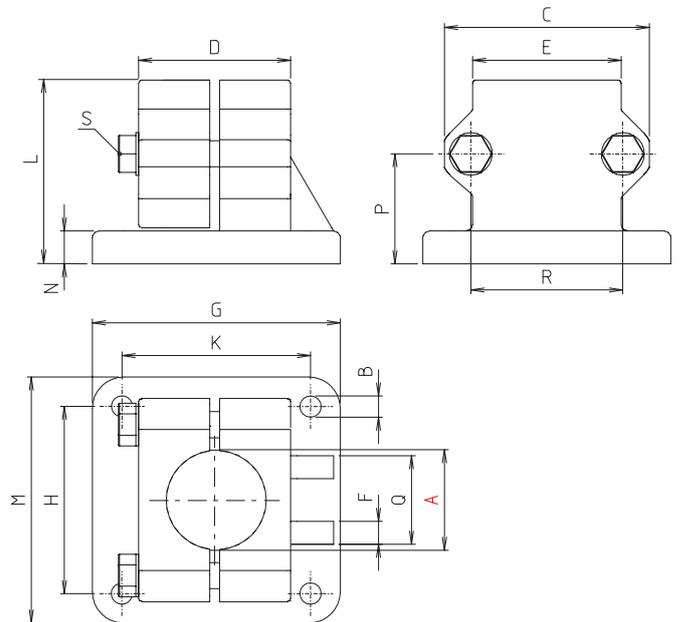

FRR - Série industrie

[mm]

Code No.	Type	A	B	C	D	E	F	G	H	K	L	M	N	P	Q	R	m [g]	Levier de serrage S Code No.
13250003020	FRR 25	25,2	7	62	45	45	5	75	57	57	56	75	10	33,5	25	46	303	9022501
13300003020	FRR 30	30,2															287	
13350003020	FRR 35	35,2	9	75	60	60	5	100	76	76	71	100	10	43	25	57	612	9022801
13400003020	FRR 40	40,2															597	

Solid Clamps – Pieds

Principe de commande:

- Vis galvanisées en équipement standard
- Levier de serrage à commander séparément. Livré non monté. Voir dernière colonne du tableau et page 222

Sur demande:

- Vis en acier inoxydable
- En couleur
- Polissage à billes

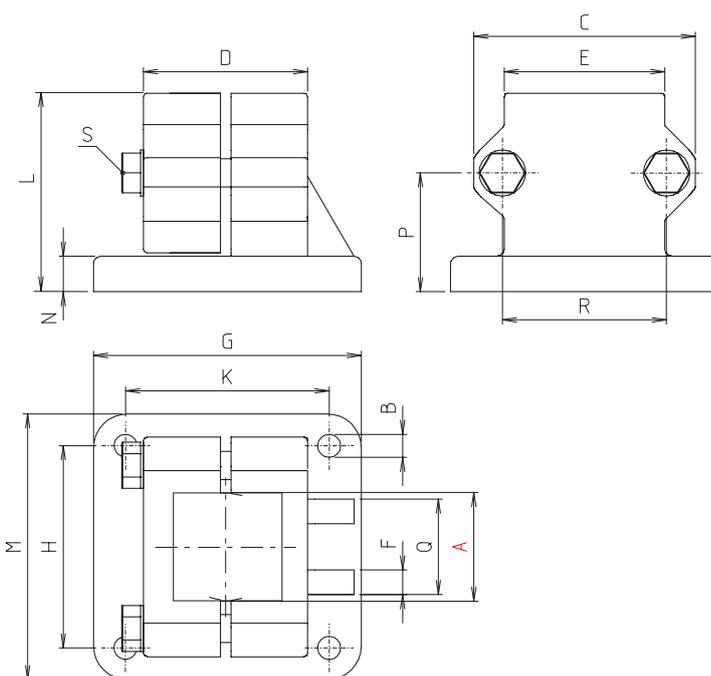

FV - Série industrie

[mm]

Code .	Type	A	B	C	D	E	F	G	H	K	L	M	N	P	Q	R	m [g]	Levier de serrage S Code No.
13200005020	FV 20	20,5															320	9022501
13250005020	FV 25	25,3	7	62	45	45	5	75	57	57	56	75	10	33,5	25	46	292	
13300005020	FV 30	30,3															278	
13350005020	FV 35	35,4	9	75	60	60	5	100	76	76	73	100	12	43	32	57	587	9022801
13400005020	FV 40	40,4															581	



Les cotes de raccordement sont largement adaptées à nos techniques de profilés BLOCAN®.

Solid Clamps – Pieds



Plaque sans pied

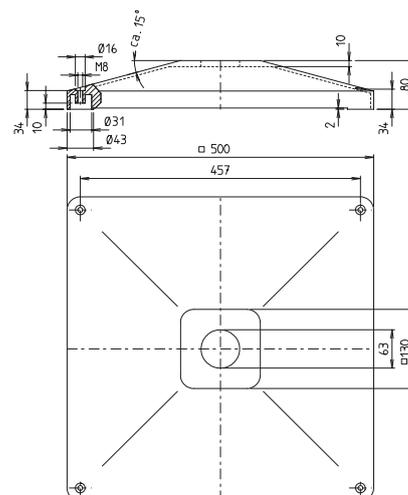

FP - Série industrie

[mm]

Code No.	Type	m [g]
130000100_ _ _ _	FP	4440



Plaque avec pied type FS

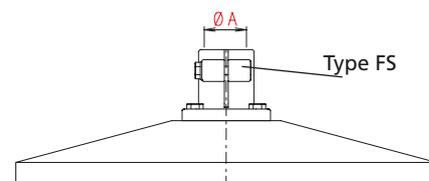

FP FS - Série industrie

[mm]

Code No.	Type	A	m [g]
133200120_ _ _ _	FP FS 32	32,15	4946
134000120_ _ _ _	FP FS 40	40,15	4881
134800120_ _ _ _	FP FS 48	48,2	5141
135000120_ _ _ _	FP FS 50	50,2	5111



Plaque avec pied type FRR

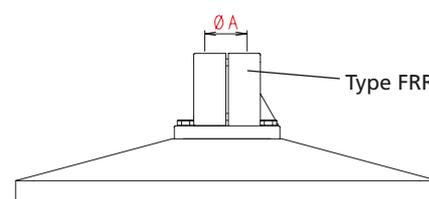

FP FRR - Série industrie

[mm]

Code No.	Type	A	m [g]
134000130_ _ _ _	FP FRR 40	40,2	5037
134200130_ _ _ _	FP FRR 42	42,3	5854
134500130_ _ _ _	FP FRR 45	45,3	5799
134800130_ _ _ _	FP FRR 48	48,3	5783
135000130_ _ _ _	FP FRR 50	50,3	579



Plaque avec pied type FV

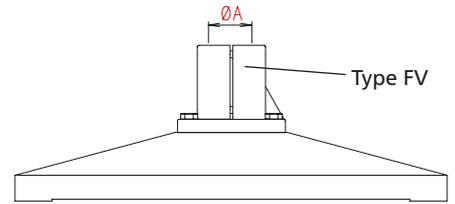

FP FV - Série industrie

[mm]

Code No.	Type	A	m [g]
133500150_ _ _ _	FP FV 35	35,4	5027
134000150_ _ _ _	FP FV 40	40,4	5010

Code No. +

Surface:

2 = naturel
 A = RAL 7035, gris clair
 B = RAL 7030, gris pierre
 C = RAL 9005, noir foncé
 D = RAL 1021, jaune

Equipement

pour serrage A:

0 = vis
 1 = 1 levier
 2 = 2 leviers
 3 = 3 leviers
 4 = 4 leviers

Version:

F = Alésage fileté

Charge:

0= sans charge,
 moment de renversement 15 Nm

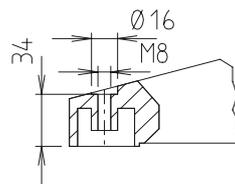

2 = Pied en caoutchouc

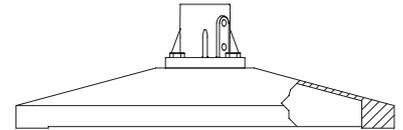

X = cavité avec béton (m=14kg)
 moment de renversement 65 Nm

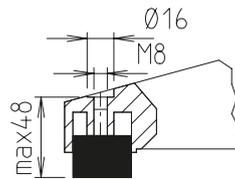

3 = Vérin réglable

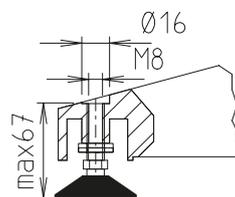
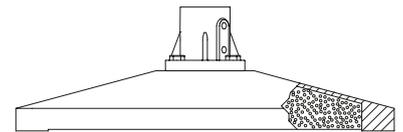

4 = Roue guide avec frein

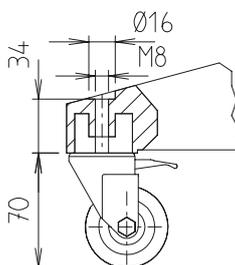

Exemple de commande:

Plaque FP avec pied F 50,
 surface poncée,
 équipé avec vis,
 version avec pied en caoutchouc,
 chargé d'une plaque en béton

135000120 2 0 2 X

Solid Clamps – Pieds

Principe de commande:

- Vis galvanisées en équipement standard
- Levier de serrage à commander séparément. Livré non monté. Voir dernière colonne du tableau et page 222

Sur demande:

- Vis en acier inoxydable
- En couleur
- Polissage à billes

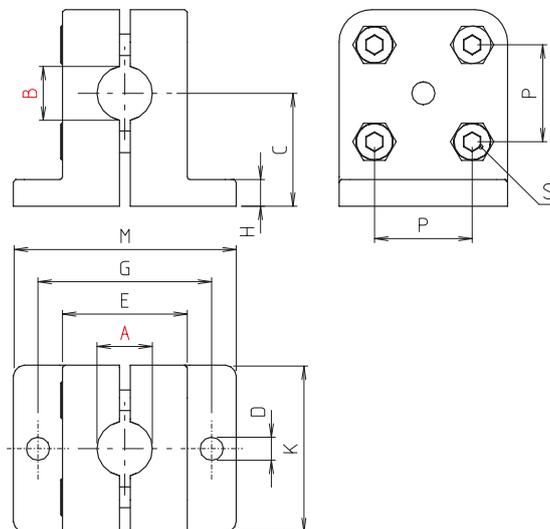

FFKR - Série bloc

[mm]

Code No.	Type	A	B	C	D	E	G	H	K	L	M	P	S	m [g]
290800020266	FFKR 8*	8	8	21	4	23	32	5	31	36	41	18	M4x18	62
291000020266	FFKR 10	10	10											58

* Ø 8 réduit à l'aide d'une douille de serrage

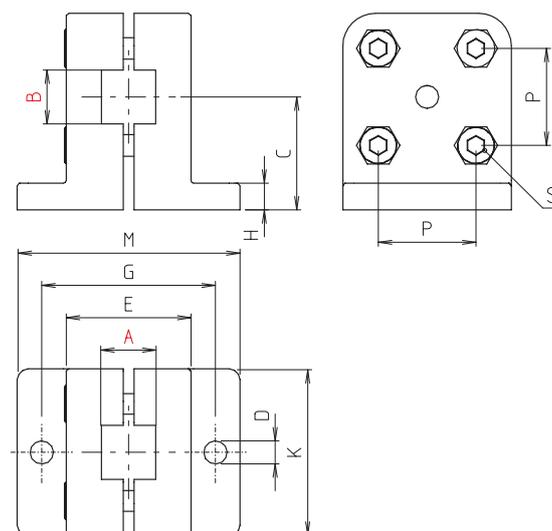

FFKV - Série bloc

[mm]

Code No.	Type	A	B	C	D	E	G	H	K	L	M	P	S	m [g]
291000030266	FFKV 10	10	10	21	4	23	32	5	31	36	41	18	M4x18	5

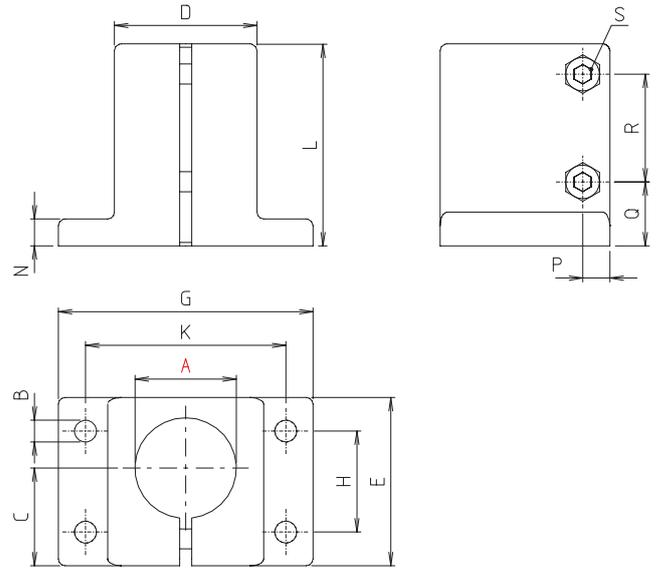

FSB - Série bloc

[mm]

Code No.	Type	A	B	C	D	E	G	H	K	L	N	P	Q	R	m [g]	Levier de serrage S Code No.
23400000026	FSB 40	40,15	9	38	53	65	92	42	74	75	11	9,5	24	40	500	9022501

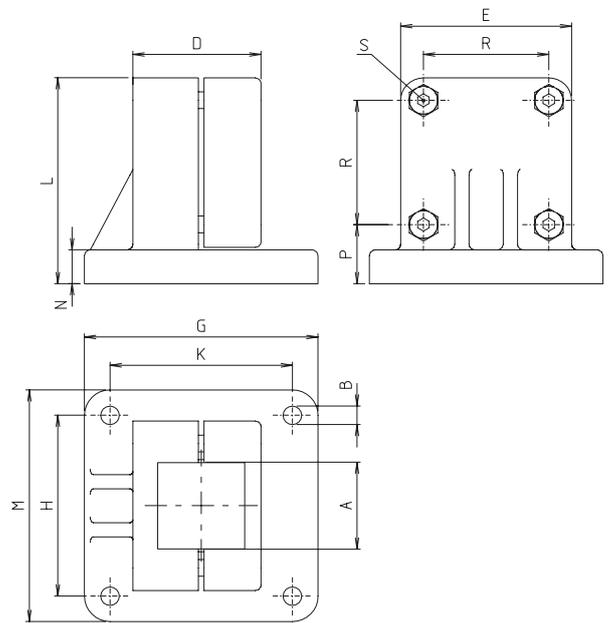

FV - Série bloc

[mm]

Code No.	Type	A	B	D	E	G	H	K	L	M	N	P	R	m [g]	Levier de serrage S Code No.
23300005026	FV 30	30,3	6,5	48	60	82	64	64	73	82	12	21	44	403	9021401
23400005026	FV 40	40,4	6,5	62	70	95	76	76	85	95	14	23,5	53	600	9021601
23500005026	FV 50	50,5	9	79	86	125	98	98	102	125	12	26,5	65	1333	9022901
23800005026	FV 80*	80,7	11	122	130	240	100	190	150	130	20	35	100	3741	9024601

* Avec plaque de bride fendue

Solid Clamps – Pieds

Principe de commande:

- Vis galvanisées en équipement standard
- Levier de serrage à commander séparément. Livré non monté. Voir dernière colonne du tableau et page 222

Sur demande:

- Vis en acier inoxydable
- En couleur
- Polissage à billes

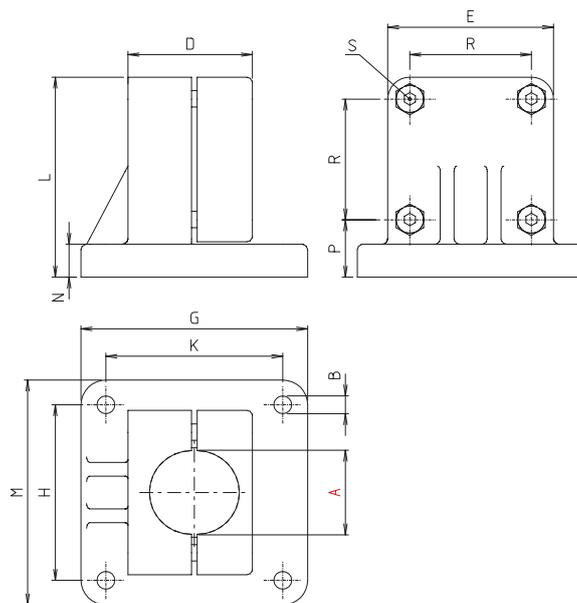

FRR - Série bloc

[mm]

Code No.	Type	A	B	D	E	G	H	K	L	M	N	P	R	m [g]	Levier de serrage S Code No.
23300003026	FRR 30	30,2	7	48	60	82	64	64	73	82	12	21	44	414	90214601
23350003026	FRR 35	35,2	7	62	70	95	76	76	85	95	14	24	55	670	9021601
23400003026	FRR 40	40,2		70	95	76	76	85	95	14	24	53	613		
23420003026	FRR 42	42,3	9	79	86	125	98	98	102	125	12	27	64	1414	9022901
23450003026	FRR 45	45,3												1359	
23480003026	FRR 48	48,3												1343	
23500003026	FRR 50	50,3												1332	
23800003026	FRR 80*	80,7	11	120	130	240	100	190	150	130	20	35	100	3928	9024601

* Avec plaque de bride fendue

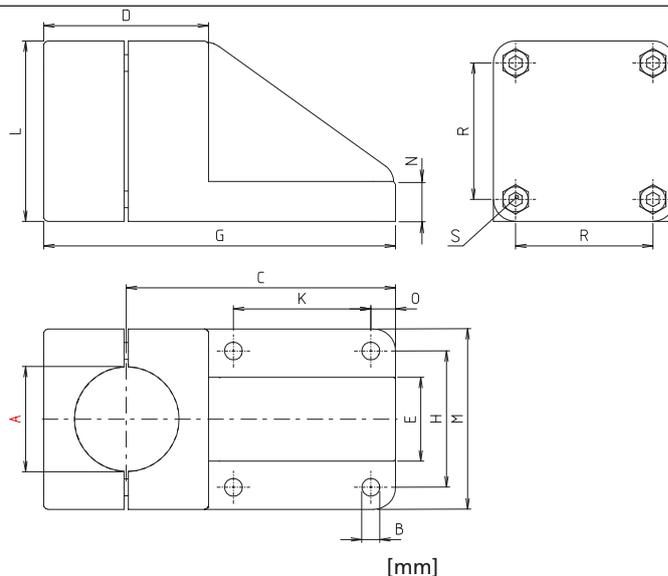

FRA - Série bloc

[mm]

Code No.	Type	A	B	C	D	E	G	H	K	L	M	N	O	R	m [g]	Levier de serrage S Code No.
23420002026	FRA 42	42,3	9	128	79	40	167	65	65	86	86	19	10,5	65	1198	9022901
23450002026	FRA 45	45,3													1217	
23480002026	FRA 48	48,3													1231	
23500002026	FRA 50	50,3													1205	
23600002026	FRA 60	60,4	9	147	90	46	192	78	78	100	100	22	11	78	1690	9021401

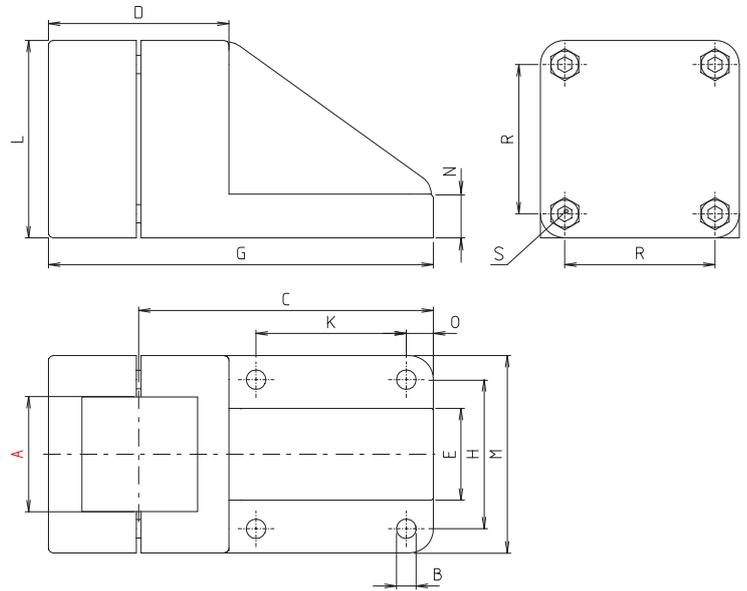

FVA - Série bloc

[mm]

Code No.	Type	A	B	C	D	E	G	H	K	L	M	N	O	R	m [g]	Levier de serrage S Code No.
23500007026	FVA 50	50,5	9	127,5	79	40	167	65	65	86	86	19	10,5	65	1146	9022901
23600007026	FVA 60	60,6	9	147	90	46	192	78	78	100	100	22	11	78	1635	9023001

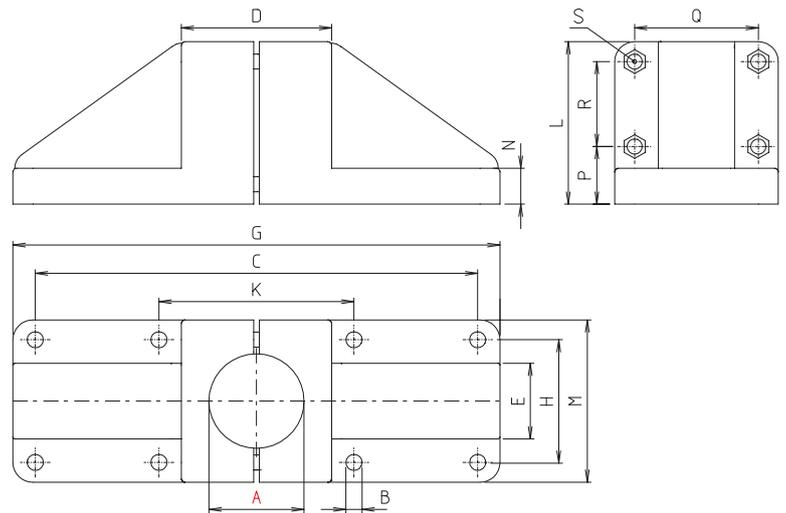

FRAA - Série bloc

[mm]

Code No.	Type	A	B	C	D	E	G	H	K	L	M	N	P	Q	R	m [g]	Levier de serrage S Code No.
23420016026	FRAA 42	42,3														1570	9022901
23450016026	FRAA 45	45,3														1250	
23480016026	FRAA 48	48,3	9	235	79	40	256	65	105	86	86	19	28,5	65	47	1231	
23500016026	FRAA 50	50,3														1518	
23600016026	FRAA 60	60,4	9	272	90	46	294	78	116	100	100	22	30,5	78	58,5	2253	9023001

Solid Clamps – Pieds

Principe de commande:

- Vis galvanisées en équipement standard
- Levier de serrage à commander séparément. Livré non monté. Voir dernière colonne du tableau et page 222

Sur demande:

- Vis en acier inoxydable
- En couleur
- Polissage à billes

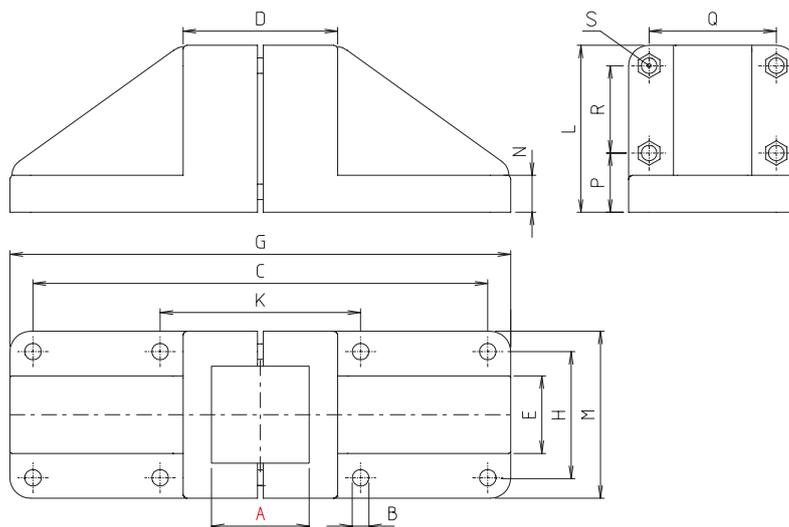

FVAA - Série bloc

[mm]

Code No.	Type	A	B	C	D	E	G	H	K	L	M	N	P	Q	R	m [g]	Levier de serrage S Code No.
23500017026	FVAA 50	50,5	9	235	79	40	256	65	105	86	86	19	28,5	65	47	1479	9022901
23600017026	FVAA 60	60,6	9	272	90	46	294	78	116	100	100	22	30,5	78	58,5	2220	9023001

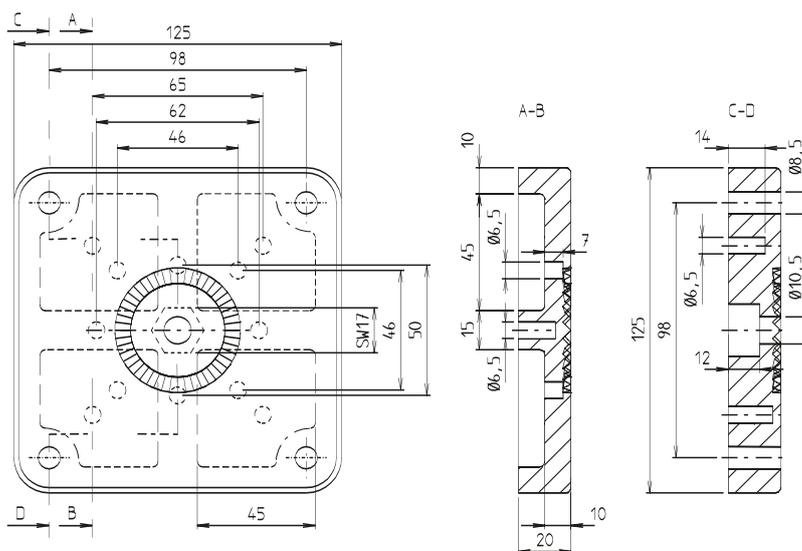

FPU - Série bloc

[mm]

Code No.	Type	m [g]
2340001902	FPU 40	60

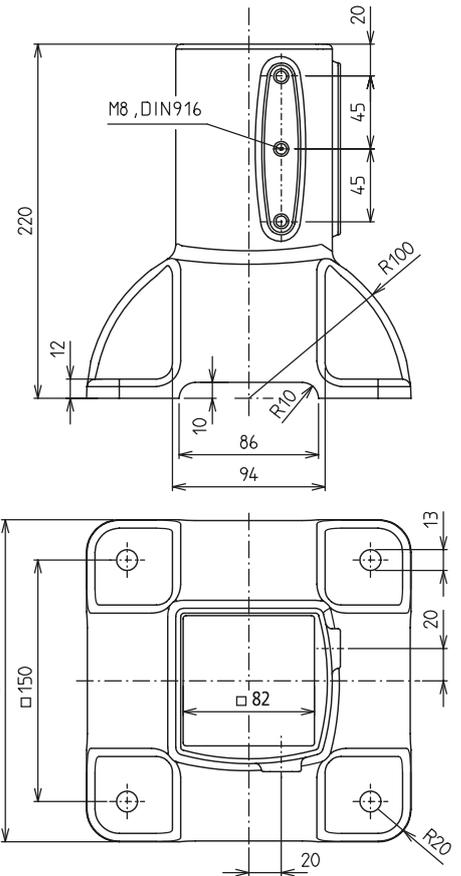

BAK-80 - Série bloc

[mm]

Code No.	Type	m [g]
4040501	BAK-80	1880



Solid Clamps – Pieds



Plaque sans pied

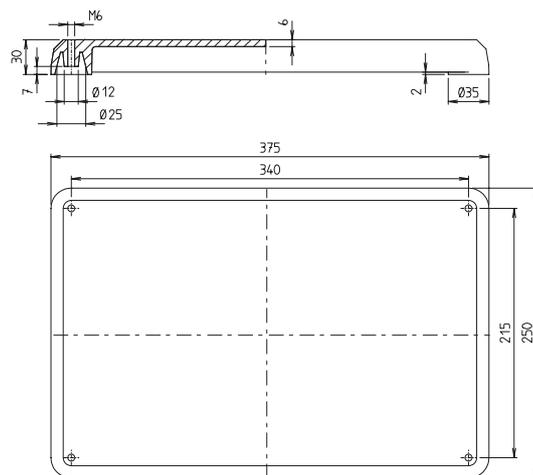

FP - Série bloc

[mm]

Code No.	Type	m [g]
230000100_ _ _ _	FP	1960



Plaque avec pied type FS

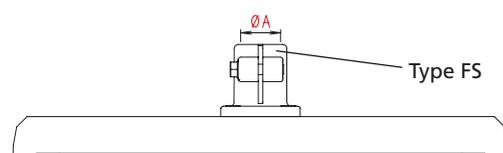

FP FS - Série bloc

[mm]

Code No.	Type	A	m [g]
232000120_ _ _ _	FP FS 20	20	2141
233000120_ _ _ _	FP FS 30	30,1	2400
233200120_ _ _ _	FP FS 32	32,15	2459
233500120_ _ _ _	FP FS 35	35,15	2434
234000120_ _ _ _	FP FS 40	40,15	2391



Plaque avec pied type FRR

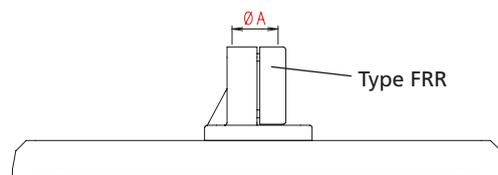

FP FRR - Série bloc

[mm]

Code No.	Type	A	m [g]
233000130_ _ _ _	FP FRR 30	30,15	2364
234000130_ _ _ _	FP FRR 40	40,2	256



Plaque avec pied type FV

FP FV - Série bloc

[mm]

Code No.	Type	A	m [g]
233000150 _ _ _ _	FP FV 30	30,3	2353
234000150 _ _ _ _	FP FV 40	40,4	2550

Code No. +

Surface:

- 2 = naturel
- A = RAL 7035, gris clair
- B = RAL 7030, gris pierre
- C = RAL 9005, noir foncé
- D = RAL 1021, jaune

Équipement pour serrage A:

- 6 = vis
- 1 = 1 levier
- 2 = 2 leviers
- 3 = 3 leviers
- 4 = 4 leviers

Version: F = Alésage fileté

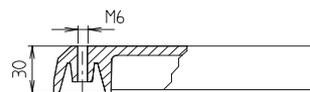

2 = Pied en caoutchouc

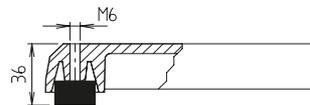

3 = Vérin réglable

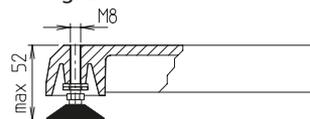

4 = Roue guide avec frein

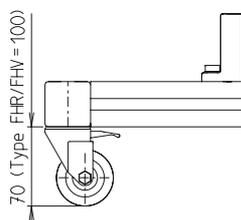

Charge:

0 = sans charge,
moment de renversement 15 Nm

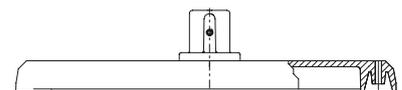

Y = cavité avec plaque en acier (m=4,6kg)
moment de renversement 6 Nm

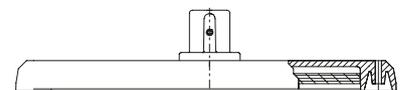

Exemple de commande:

Plaque FP avec pied FS 40,
surface poncée, équipé avec vis,
version avec pied en caoutchouc,
chargé d'une plaque en acier

234000120 2 6 2 Y

Solid Clamps – Pieds

Principe de commande:

- Vis galvanisées en équipement standard
- Levier de serrage à commander séparément. Livré non monté. Voir dernière colonne du tableau et page 222

Sur demande:

- Anodisé noir



FS - Série quad®

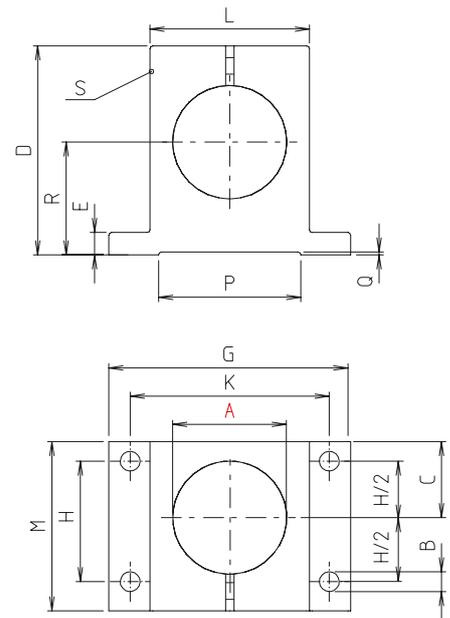

[mm]

Code No.	Type	A	B	C	D	E	G	H	K	L	M	P	Q	R	m [g]	Levier de serrage S Code No.
53300000030	FS 30	30,1	7	21	58	6	70	28	56	42	49	35	1	30	182	9300101
53400000030	FS 40	40,1	7	28	74	8	85	40	70	56	62	50	1	40	369	9301401
53500000030	FS 50	50,2	9	35	92	10	110	50	90	70	77	60	1	50	738	9300401
53600000030	FS 60	60,2	9	42	112,5	12	137	60	110	85	90	71	2	60	1500	9022801



FR - Série quad®

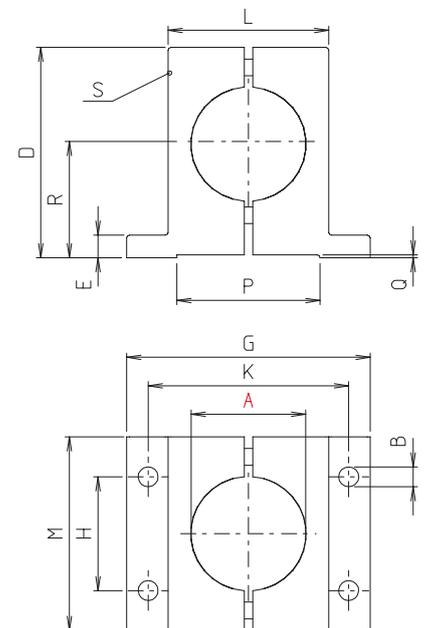

[mm]

Code No.	Type	A	B	D	E	G	H	K	L	M	P	Q	R	m [g]	Levier de serrage S Code No.
53300009030	FR 30	30,1	7	58	6	70	28	56	42	56	35	1	30	223	9300101
53400009030	FR 40	40,2	7	74	8	85	40	70	56	68	50	1	40	431	9301401
53500009030	FR 50	50,3	9	92	10	110	50	90	70	84	60	1	50	857	9300401
53600009030	FR 60	60,2	9	112,5	12	137	80	120	97	105	71	2	60	-	9022801
53800009030	FR 80	80,6	11	142	16	156	80	135	112	126	80	2	80	2858	9300801

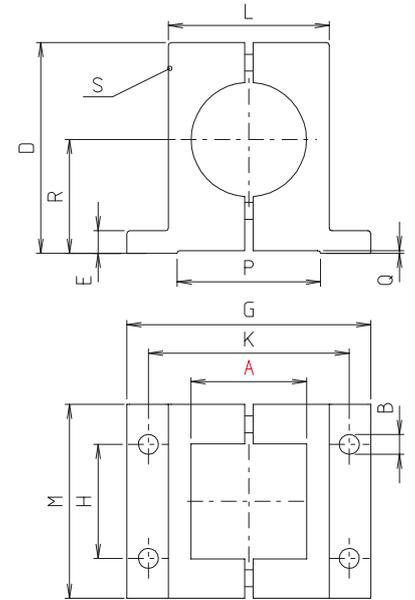
FV - Série quad®

Code No.	Type	A	B	D	E	G	H	K	L	M	P	Q	R	m [g]	Levier de serrage S Code No.
53300005030	FV 30	30,2	7	58	6	70	28	56	42	56	35	1	30	197	9300101
53400005030	FV 40	40,3	7	73,5	8	85	40	70	56	68	50	1	40	375	9301401
53500005030	FV 50	50,4	9	92	10	110	50	90	70	84	60	1	50	750	9300401
53600005030	FV 60	60,4	9	112,5	12	137	80	120	97	105	71	2	60	-	9022801
53800005030	FV 80	80,4	11	142	16	156	80	135	112	126	80	2	80	2508	9300801

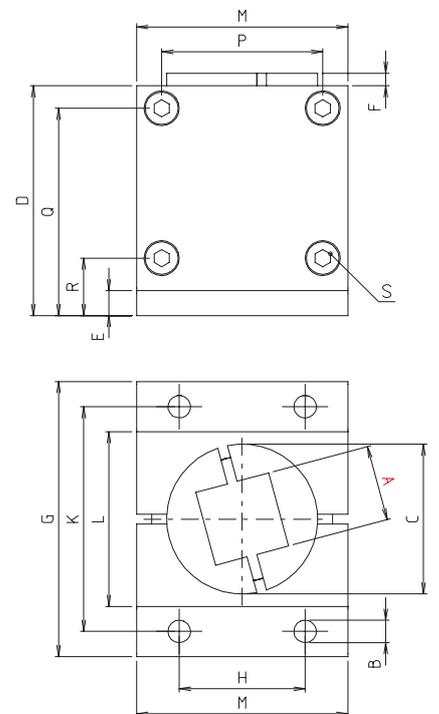

360°

FRS - Série quad®

Code No.	Type	A	B	C	D	E	F	G	H	K	L	M	P	Q	R	m [g]	Levier de serrage S Code No.
53300018030	FRS 30	30,3	9	70	92	10	5	110	50	90	70	84	64	83	135	1006	9300401
53500018030	FRS 50	50,5	11	122	142	16	5	156	80	135	112	126	100	130	30	3100	9300801



Versions::

■ Colliers emboîtables

Livrable
sur stock

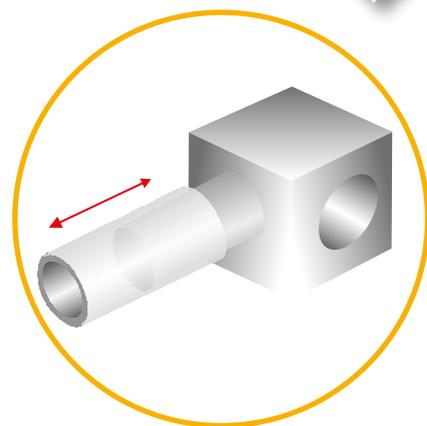

Éléments monoblocs

✓ Pour un montage plus rapide et économique



Série industrie

- Fonte d'aluminium
- Grande diversité
- Éléments monoblocs



Série quad®

- Profilé en aluminium extrudé
- Contrainte de couple maximale
- Surface anodisée haute qualité
- Éléments monoblocs et en plusieurs parties



Éléments en plusieurs parties

✓ Également conçus pour les montages et extensions a posteriori



Série bloc

- Fonte d'aluminium
- Contrainte de couple plus élevée Ebene
- Contours extérieurs plans
- Éléments en plusieurs parties

Charges admissibles

ATTENTION !

Les valeurs données dans les tableaux ne constituent pas un engagement sur les valeurs ni une garantie de résultat à propos de nos produits.

Il ne s'agit que de valeurs indicatives non contractuelles, qui peuvent dans certains cas ne pas être atteintes, dépendant notamment de divers facteurs liés aux applications, comme la température ou la nature de la surface des tubes.

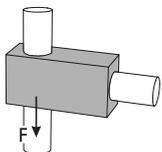

Adhérence F [KN]

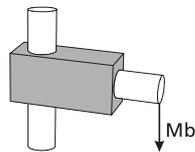

Moment de flexion Mb [Nm]

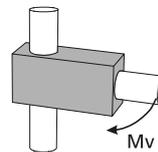

Couple de torsion Mv [Nm]

Couple de serrage des vis:

M6: 10 Nm

M8: 25 Nm

M10: 50 Nm

Talle	18			30			40			50			60			80		
	F	Mb	Mv	F	Mb	Mv	F	Mb	Mv	F	Mb	Mv	F	Mb	Mv	F	Mb	Mv
Série industrie																		
S	1,1	38	18	4	316	87	4,7	605	79	5	850	363	13	1500				

Talle	18			30			40			50			60			80		
	F	Mb	Mv	F	Mb	Mv	F	Mb	Mv	F	Mb	Mv	F	Mb	Mv	F	Mb	Mv
Série bloc																		
SR													8,1	441	255			
SV													5,9	471	329			

Talle	18			30			40			50			60			80		
	F	Mb	Mv	F	Mb	Mv	F	Mb	Mv	F	Mb	Mv	F	Mb	Mv	F	Mb	Mv
Série quad®																		
SFK	1,6	188	33	1,1	295	89	6,3	994	159									

Solid Clamps – Colliers emboîtables

Raccords tubulaires
perpendiculaires

Série industrie



Série bloc



Série quad®



Solid Clamps – Colliers emboîtables

Principe de commande:

- Vis galvanisées en équipement standard
- Levier de serrage à commander séparément. Livré non monté. Voir dernière colonne du tableau et page 222

Sur demande:

- Vis en acier inoxydable
- En couleur
- Polissage à billes



Type: S 18/18, S 20/20, S 25/25, S 30/30, S 40/40, S 50/50, S 60/60



Type: S 20/30, S 25/30

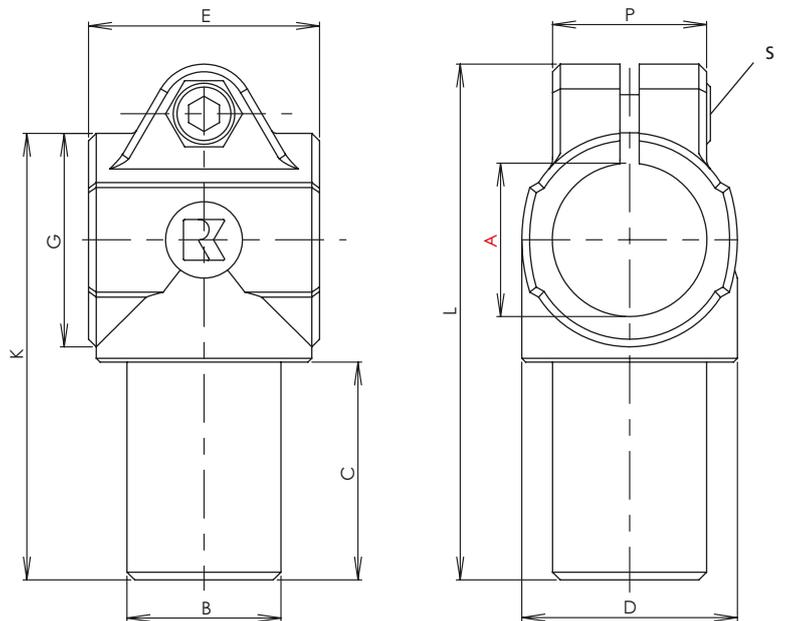

S - Série industrie

[mm]

Code No.	Type	A	B	C	D	E	G	K	L	P	m [g]	Levier de serrage S Code No.
16181800020	S 18/18	18,1	18,1	33	26	32	26	62	72,5	21	56	90209
16202000020	S 20/20	20	20	42	40	45	40	87	95	33	180	9022201
16203000020	S 20/30	20	30						95		205	
16252500020	S 25/25	25,1	25,1						100		188	
16253000020	S 25/30	25,1	30						95		185	
	S 28/30*											
16303000020	S 30/30	30,1	30,1	42	40	45	40	87	100	33	174	9022201
16404000020	S 40/40	40,17	40,17	57	56	60	56	117	135	40	484	90250
16505000020	S 50/50	50,2	50	67	66	70	66	137	154	45	623	90251
16606000020	S 60/60	60,27	60,1	82	80	85	80	165	188	58	1128	9025301

*Avec machon adaptateur R28, voir accessoires page 223

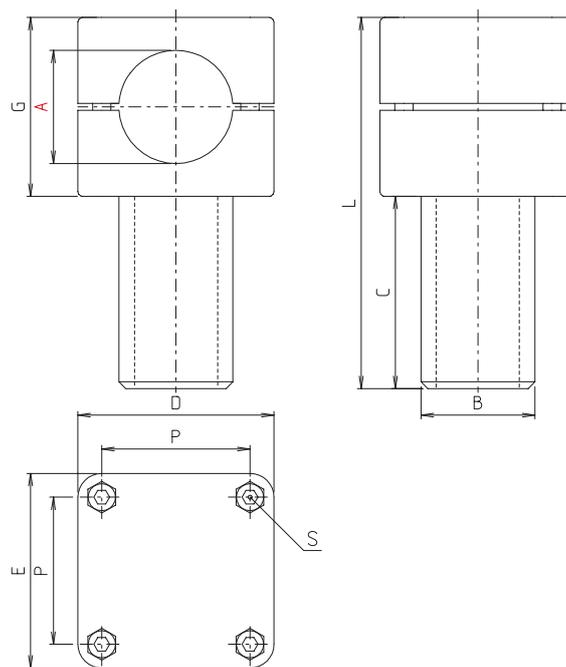

SR - Série bloc

[mm]

Code No.	Type	A	B	C	D	E	G	L	P	m [g]	Levier de serrage S Code No.
26420003026	SR 42	42,3	50	85	86	86	79	164	65	1134	9022901
26500003026	SR 50	50,3								1116	

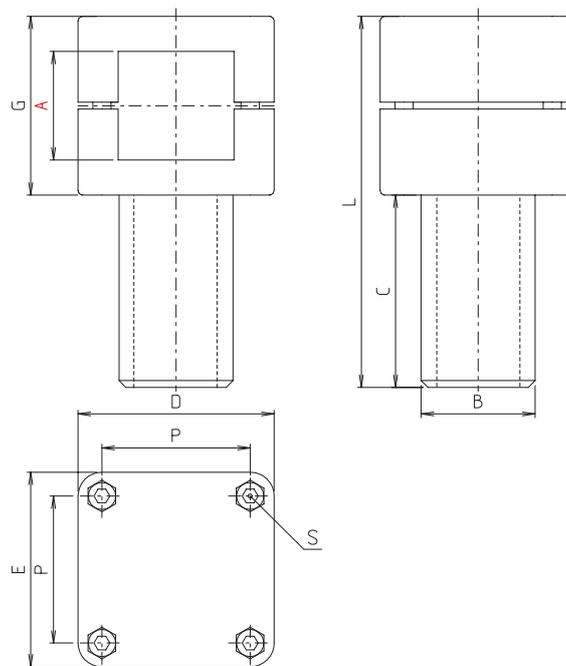

SV - Série bloc

[mm]

Code No.	Type	A	B	C	D	E	G	L	P	m [g]	Levier de serrage S Code No.
26500005026	SV 50	50,5	50	85	86	86	79	164	65	1058	9022901

Solid Clamps – Colliers emboîtables

Principe de commande:

- Vis galvanisées en équipement standard
- Levier de serrage à commander séparément. Livré non monté. Voir dernière colonne du tableau et page 222

Sur demande:

- Vis en acier inoxydable
- En couleur
- Polissage à billes

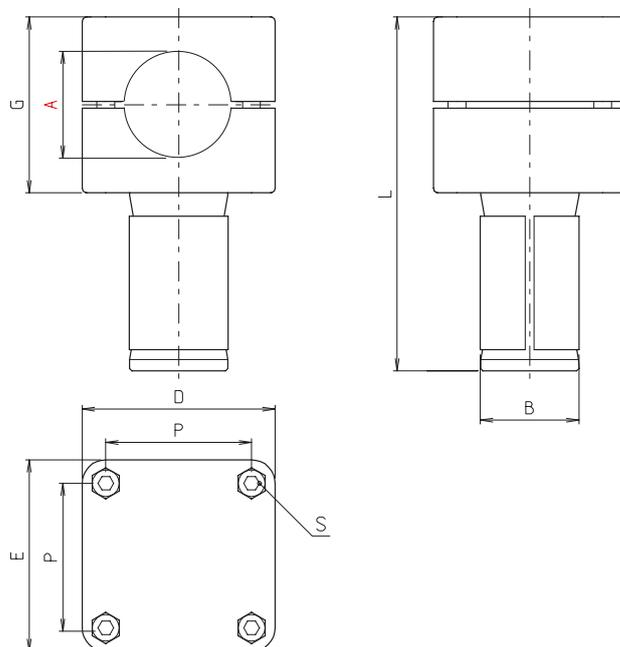
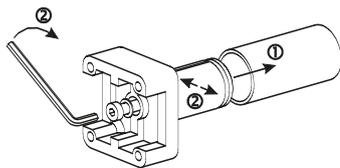

SRX - Série bloc

[mm]

Code No.	Type	A	B	D	E	G	L	P	m [g]	Levier de serrage S Code No.
26500009026	SRX 50	50,3	43,8	86	86	79	164	65	120	9022901

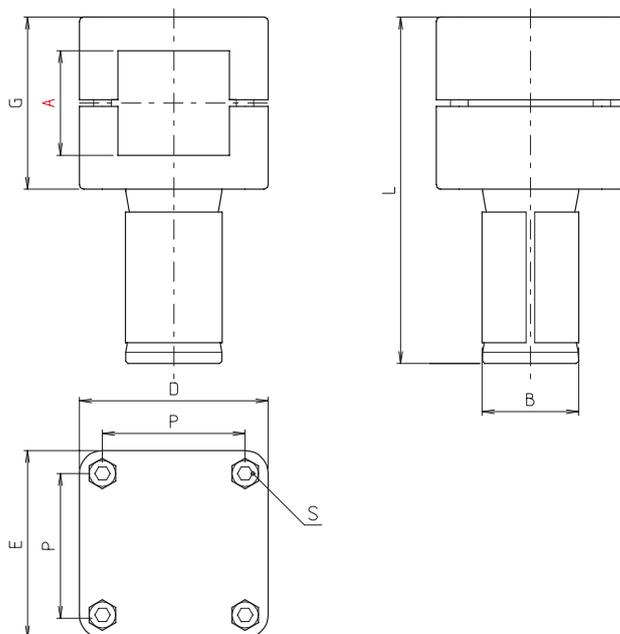
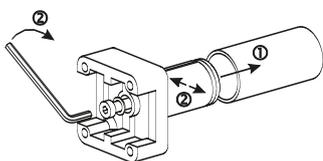

SVX - Série bloc

[mm]

Code No.	Type	A	B	D	E	G	L	P	m [g]	Levier de serrage S Code No.
26500010026	SVX 50	50,5	43,8	86	86	79	164	65	1200	9022901

- Poulie: Polyamide
- Charge max. 560 N

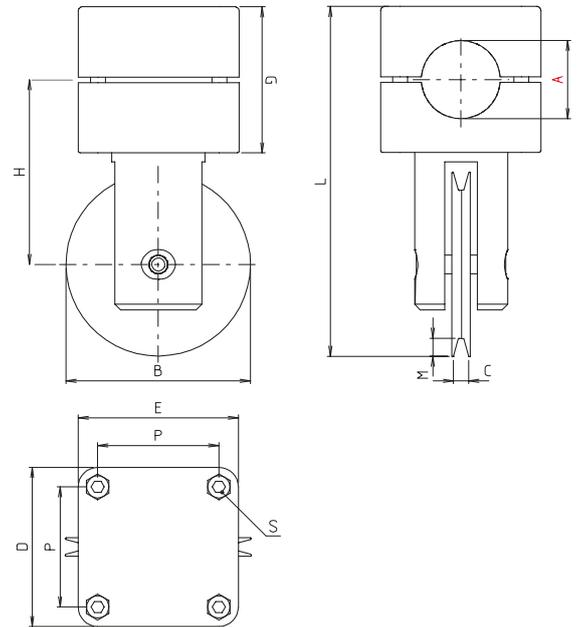

SRO - Série bloc

[mm]

Code No.	Type	A	B	C	D	E	G	H	L	M	P	m [g]	Levier de serrage S Code No.
26420007026	SRO 42	42,3	100	8	86	86	79	100	189,5	10	65	1170	9022901
26450007026	SRO 45	45,3										1180	
26500007026	SRO 50	50,3										1200	

- Poulie: Polyamide
- Charge max. 560 N

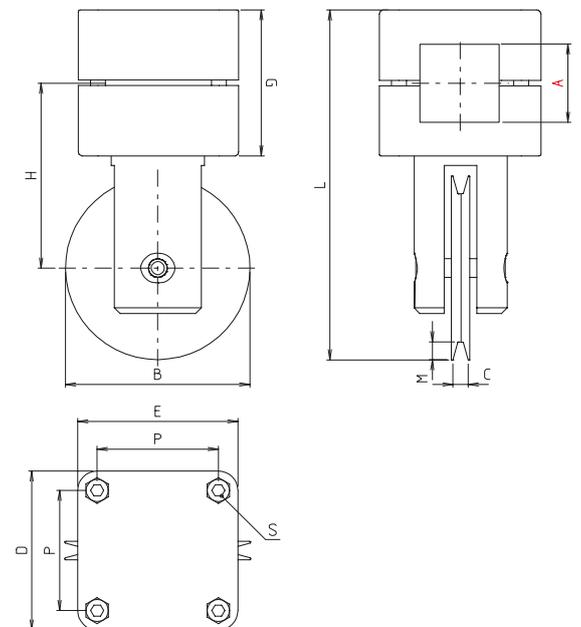

SVO - Série bloc

[mm]

Code No.	Type	A	B	C	D	E	G	H	L	M	P	m [g]	Levier de serrage S Code No.
26500008026	SVO 50	50,5	100	8	86	86	79	100	189,5	10	65	1190	9022901

Solid Clamps – Colliers emboîtables

Principe de commande:

- Vis galvanisées en équipement standard
- Levier de serrage à commander séparément. Livré non monté. Voir dernière colonne du tableau et page 222

Sur demande:

- Anodisé noir

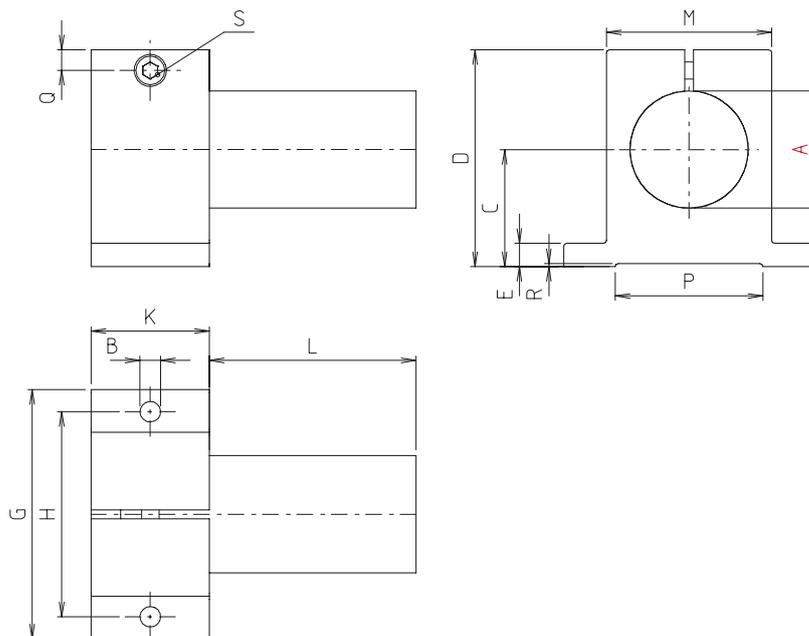

SFK - Série quad®

[mm]

Code No.	Type	A	B	C	D	E	G	H	K	L	M	P	Q	R	m [g]	Levier de serrage S Code No.
56300015030	SFK 30	30	7	30	58	6	70	56	30	42	42	35	7	1	187	9300101
56400015030	SFK 40	40	7	40	74	8	85	70	40	56	56	50	7	1	427	9301401
56500015030	SFK 50	50	9	50	92	10	110	90	50	70	70	60	9	1	820	-



Table de photo avec raccords tubulaires quad®. La construction peut être librement adaptée aux conditions.



Versions:

■ Raccords droits

Livrable
sur stock

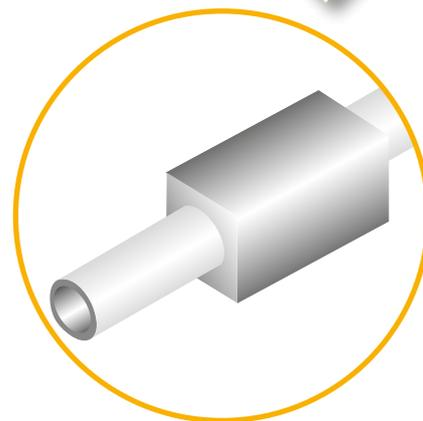

Éléments monoblocs

✓ Pour un montage plus rapide
et économique



Série industrie

- Fonte d'aluminium
- Grande diversité
- Éléments monoblocs



Série bloc

- Fonte d'aluminium
- Contrainte de couple plus élevée
- Contours extérieurs plans
- Éléments en plusieurs parties



Série quad®

- Profilé en aluminium extrudé
- Contrainte de couple maximale
- Surface anodisée haute qualité
- Éléments monoblocs et en plusieurs parties



Éléments en plusieurs parties

✓ Également conçus pour les montages et extensions a posteriori



Série quad®

- Profilé en aluminium extrudé
- Contrainte de couple maximale
- Surface anodisée haute qualité
- Éléments monoblocs et en plusieurs parties

Charges admissibles

ATTENTION !

Les valeurs données dans les tableaux ne constituent pas un engagement sur les valeurs ni une garantie de résultat à propos de nos produits.

Il ne s'agit que de valeurs indicatives non contractuelles, qui peuvent dans certains cas ne pas être atteintes, dépendant notamment de divers facteurs liés aux applications, comme la température ou la nature de la surface des tubes.

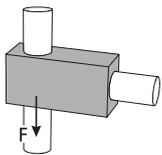

Adhérence F [KN]

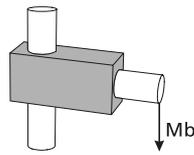

Moment de flexion Mb [Nm]

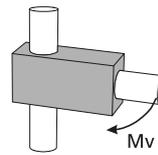

Couple de torsion Mv [Nm]

Couple de serrage des vis:

M6: 10 Nm

M8: 25 Nm

M10: 50 Nm

Talle	10			18			30			40			50			60		
	F	Mb	Mv	F	Mb	Mv	F	Mb	Mv	F	Mb	Mv	F	Mb	Mv	F	Mb	Mv
Série industrie																		
M							1,9	435		4,7	698		2,8	1000		15	2400	
MD							2,7	440		5	994		2,7	1000				
MH							4,7			10			9,4					

Talle	10			18			30			40			50			60		
	F	Mb	Mv	F	Mb	Mv	F	Mb	Mv	F	Mb	Mv	F	Mb	Mv	F	Mb	Mv
Série bloc																		
M				141			5,3	351		9,2	519		6,5	875				
MD							1,8	451		8	713		4	1000		1,5	1125	

Talle	30			40			50			80		
	F	Mb	Mv	F	Mb	Mv	F	Mb	Mv	F	Mb	Mv
Série quad®												
M	11,2	352		8,0	619		11,8	1267				
MD	6,2	324		7,8	612		8	1267				
MH	2,6			3,4			7,8					
MR	9	810		4,5	1024		12,6	1596				
MV	7,8	433		2,5	1074		7,4	1568				
MVR	3,6	491		1,9	975		7,4	1568				

Solid Clamps – Raccords droits

Raccords tubulaires
parallèles à l'axe

Série industrie



Série bloc

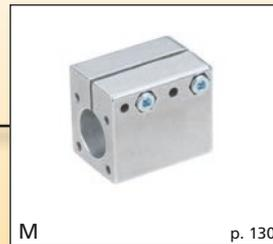

Série quad®





Solid Clamps – Raccords droits

Principe de commande:

- Vis galvanisées en équipement standard
- Levier de serrage à commander séparément. Livré non monté. Voir dernière colonne du tableau et page 222

Sur demande:

- Vis en acier inoxydable
- En couleur
- Polissage à billes

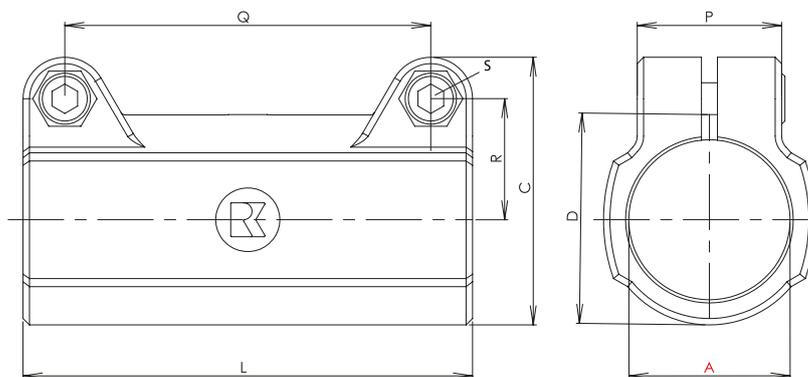

M - Série industrie

[mm]

Code No.	Type	A	C	D	L	P	Q	R	m [g]	Levier de serrage S Code No.
142000000200	M 20	20,1	53	40	80	33	60	22,5	256	9022201
142500000200	M 25	25,1							220	
	M 28*	*Avec machon adaptateur R28, voir accessoires page 223								
143000000200	M 30	30,1	53	40	80	33	60	22,5	176	9022201
144000000200	M 40	40,17	73	56	120	40	94	32	501	9025001
145000000200	M 50	50,22	84	66	140	45	114	38	650	9025101
146000000200	M 60	60,27	103	80	150	58	118	47	1092	9025301

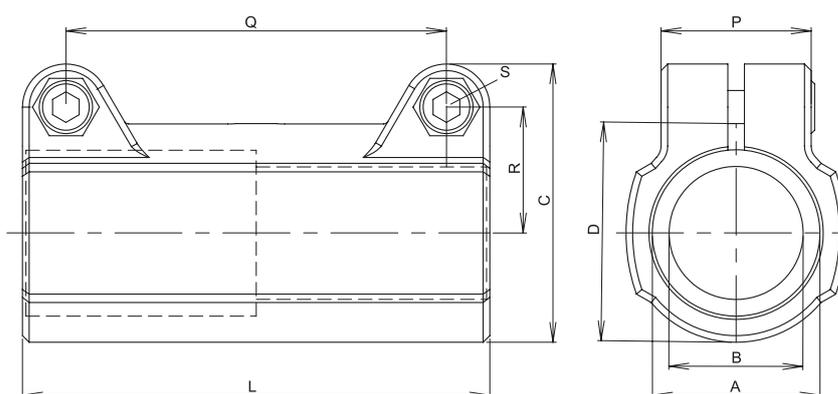

MD - Série industrie

[mm]

Code No.	Type	A	B	C	D	L	P	Q	R	m [g]	Levier de serrage S Code No.
	MD 28x25*	*Avec machon adaptateur R28, voir accessoires page 223									
143025010200	MD 30x25	30,1	25,1	53	40	80	33	60	22,5	176	9022201
144032010200	MD 40x32	40,17	32,15	73	56	120	40	94	32	501	9025001
145040010200	MD 50x40	50,22	40,17	84	66	140	45	114	38	822	9025101
146048010200	MD 60x48	60,27	48,27	103	80	150	58	118	47	1288	9025301

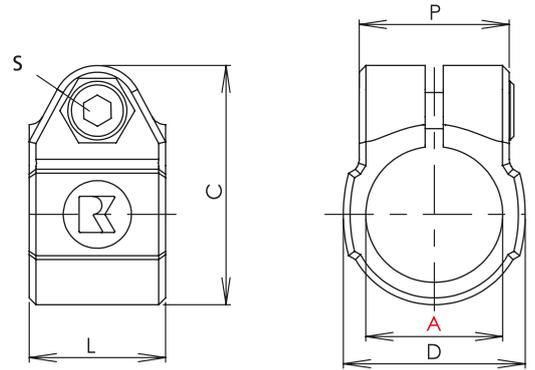

MH - Série industrie

[mm]

Code No.	Type	A	C	D	L	P	m [g]	Levier de serrage S Code No.
14300002020	MH 30	30,1	53	40	30	33	80	9022201
14400002020	MH 40	40,15	73	56	40	40	200	9025001
14500002020	MH 50	50,22	84	66	42	45	240	9025101



Vireur avec raccords de serrage quad®. Possibilité de réglage individuel.

Solid Clamps – Raccords droits

Principe de commande:

- Blocs avec vis galvanisées
- Quad® avec vis en acier inoxydable
- Levier de serrage à commander séparément. Livré non monté. Voir dernière colonne du tableau et page 222

Sur demande Blockform:

- Vis en acier inoxydable
- Polissage à billes
- En couleur

Sur demande Quad®:

- Anodisé noir

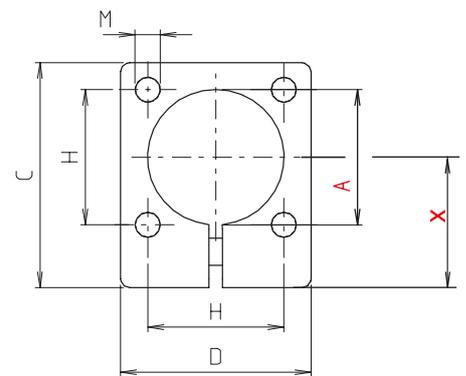
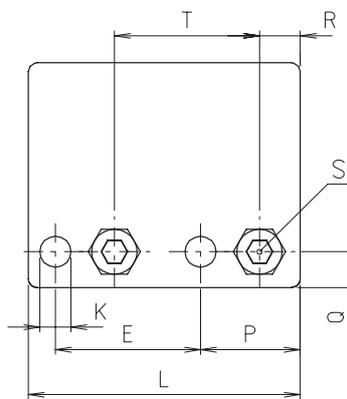

M - Série bloc

[mm]

Code No.	Type	A	C	D	E	H	K	L	M	P	Q	R	T	X	m [g]	Levier de serrage S Code No.
24180000026	M 18	18	34	26	-	-	-	40	-	-	7	7	20	21	66	9302501
24320000026	M 32	32,15	65	53	36	36	7	75	5,5	30,75	9,5	11	40	38	491	9022501
24350000026	M 35	35													468	
24480000026	M 48	48	80	65	-	46	-	90	6,5	-	9,5	12,5	46	47	721	9022701

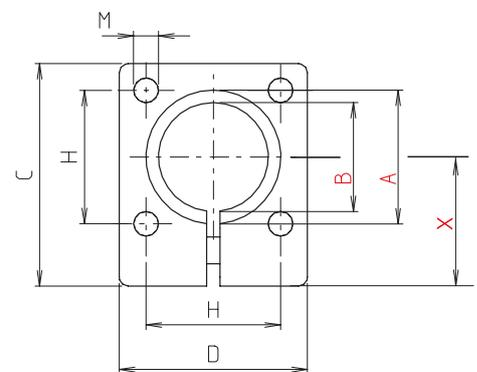
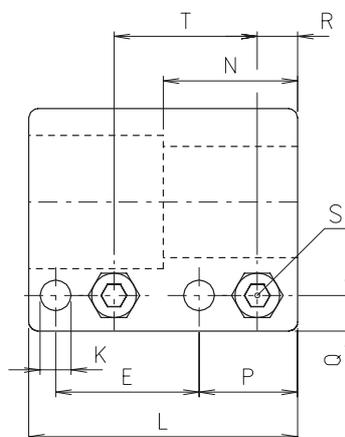

MD -Série bloc

[mm]

Code No.	Type	A	B	C	D	E	H	K	L	M	N	P	Q	R	T	X	m [g]	Levier de serrage S Code No.
244032010266	MD 40x32	40	32	65	53	36	36	8,5	75	5,5	40	30,75	9,5	11	40	38	472	9022501

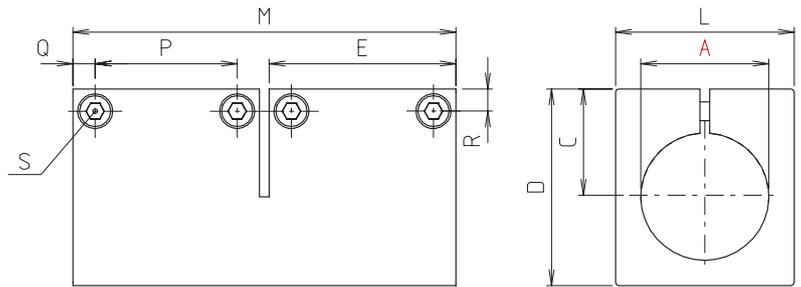

M - Série quad®

[mm]

Code No.	Type	A	C	D	E	L	M	P	Q	R	m [g]	Levier de serrage S Code No.
54300000030	M 30	30,1	28	49	44	42	90	30	7	7	326	9300101
54400000030	M 40	40,1	34	62	58,5	56	120	44,5	7	7	703	9301401
54500000030	M 50	50,2	42	77	68	70	140	48	10	9	1300	9300401

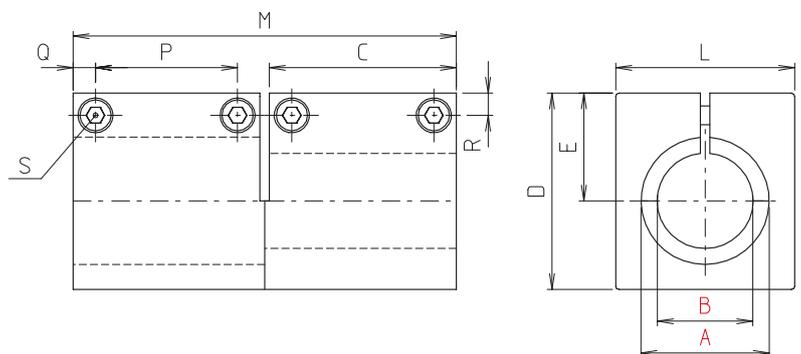

MD - Série quad®

[mm]

Code No.	Type	A	B	C	D	E	L	M	P	Q	R	m [g]	Levier de serrage S Code No.
543020010300	MD 30x20	30,1	20,1	44	49	28	42	90	30	7	7	371	9300101
544030010300	MD 40x30	40,1	30,1	58,5	62	34	56	120	44,5	7	7	789	9301401
545040010300	MD 50x40	50,2	40,2	68	77	42	70	140	48	10	9	1426	9300401

Solid Clamps – Raccords droits

Principe de commande:

- Quad® avec vis en acier inoxydable
- Levier de serrage à commander séparément. Livré non monté. Voir dernière colonne du tableau et page 222

Sur demande:

- Anodisé noir

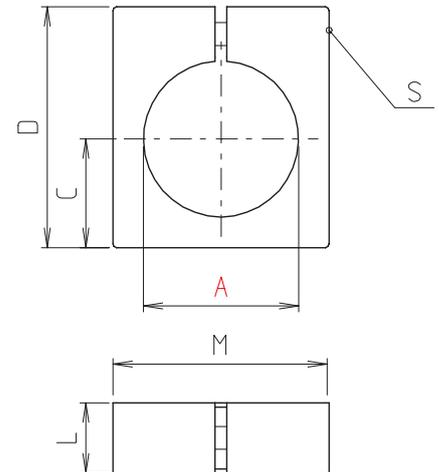

MH - Série quad®

[mm]

Code No.	Type	A	C	D	L	M	R	m [g]	Levier de serrage S Code No.
54300002030	MH 30	30,1	21	49	16	42	7	59	9300101
54400002030	MH 40	40,1	28	62	18	56	7	108	9301401
54500002030	MH 50	50,2	35	77	20	70	9	191	9300401

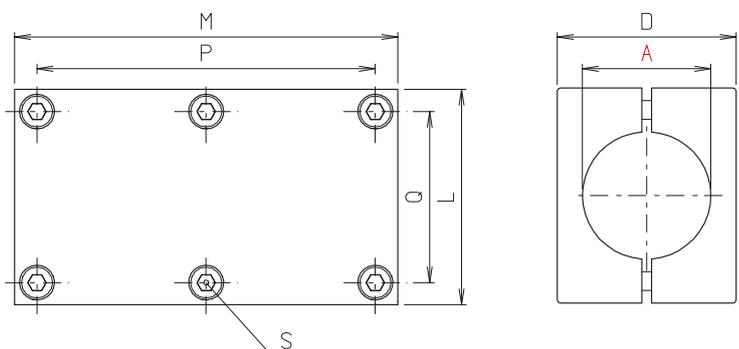

MR - Série quad®

[mm]

Code No.	Type	A	D	L	M	P	Q	m [g]	Levier de serrage S Code No.
54300003030	MR 30	30,1	42	56	90	76	42	404	9300101
54400003030	MR 40	40,2	56	68	120	106	54	800	9301401
54500003030	MR 50	50,3	70	85	140	120	67	1523	9300401
54600003030	MR 60	60,3	97	105	200	180	85	-	9022801

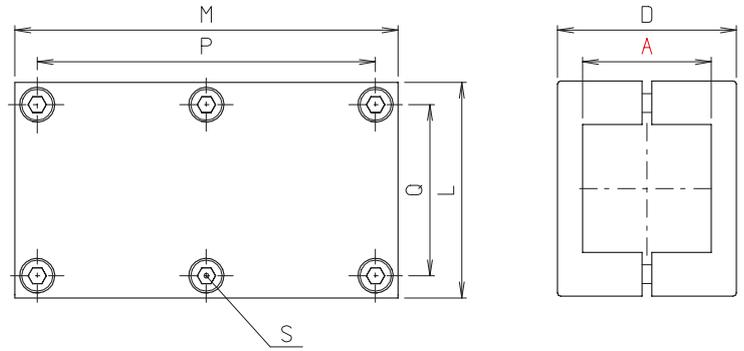
MV - Série quad®

[mm]

Code No.	Type	A	D	L	M	P	Q	m [g]	Levier de serrage S Code No.
54300004030	MV 30	30,2	42	56	90	76	42	355	9300101
54400004030	MV 40	40,3	56	68	120	106	54	705	9301401
54500004030	MV 50	50,4	70	85	140	120	67	1302	9300401
54600004030	MV 60	60,4	97	105	200	180	85	-	9022801



Versions:

■ Raccords parallèles

**Livrable
sur stock**

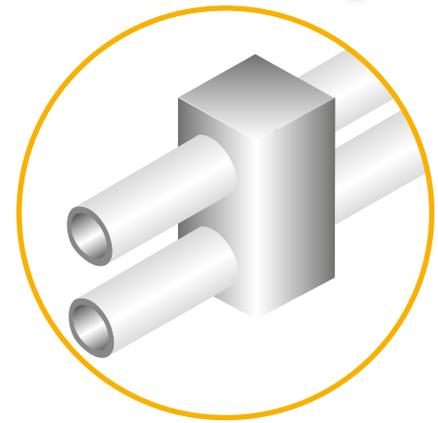

Éléments monoblocs

✓ Pour un montage plus rapide et économique



Série industrie

- Fonte d'aluminium
- Grande diversité
- Éléments monoblocs



Série bloc

- Fonte d'aluminium
- Contrainte de couple plus élevée
- Contours extérieurs plans
- Éléments en plusieurs parties

Charges admissibles

ATTENTION !

Les valeurs données dans les tableaux ne constituent pas un engagement sur les valeurs ni une garantie de résultat à propos de nos produits.

Il ne s'agit que de valeurs indicatives non contractuelles, qui peuvent dans certains cas ne pas être atteintes, dépendant notamment de divers facteurs liés aux applications, comme la température ou la nature de la surface des tubes.

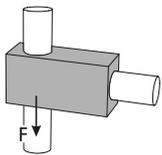

Adhérence F [KN]

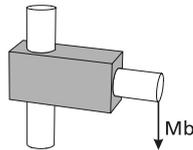

Moment de flexion Mb [Nm]

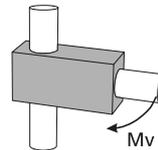

Couple de torsion Mv [Nm]

Couple de serrage des vis:

M6: 10 Nm

M8: 25 Nm

M10: 50 Nm

Talle	10			18			30			40			50			60		
	F	Mb	Mv	F	Mb	Mv	F	Mb	Mv	F	Mb	Mv	F	Mb	Mv	F	Mb	Mv
Série industrie																		
P							2,7	100	40	12,2	700	317	8,9	1250	243			

Talle	10			18			30			40			50			60		
	F	Mb	Mv	F	Mb	Mv	F	Mb	Mv	F	Mb	Mv	F	Mb	Mv	F	Mb	Mv
Série bloc																		
P				3,6	201	19	6	1210	97	11,5	1395	316	11,5	1250	181	13,5	1500	

Solid Clamps – Raccords parallèles

Raccords tubulaires
parallèles à l'axe

Série industrie

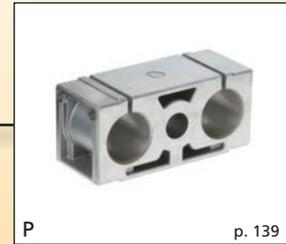

Série bloc



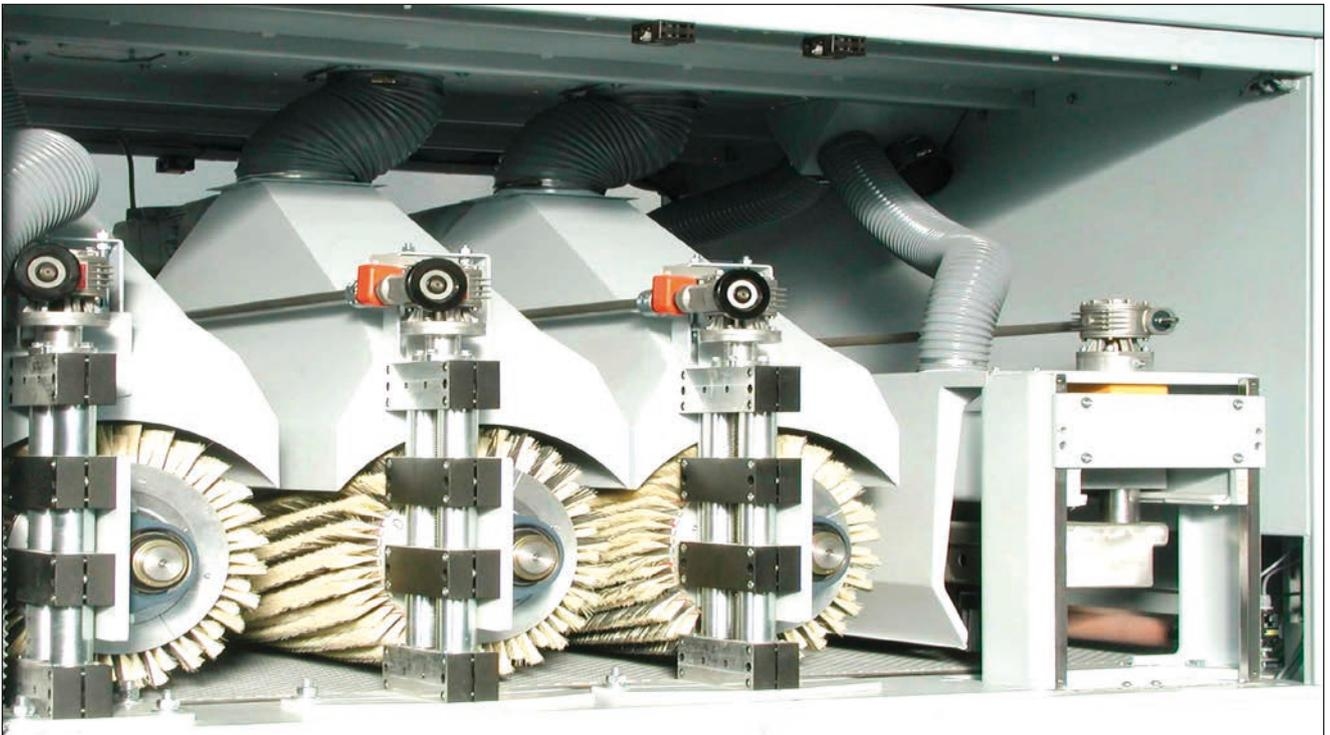

Réglage en hauteur d'une installation pour le traitement de surfaces

Solid Clamps – Raccords parallèles

Principe de commande:

- Vis galvanisées en équipement standard
- Levier de serrage à commander séparément. Livré non monté. Voir dernière colonne du tableau et page 222

Sur demande:

- Vis en acier inoxydable
- En couleur
- Polissage à billes

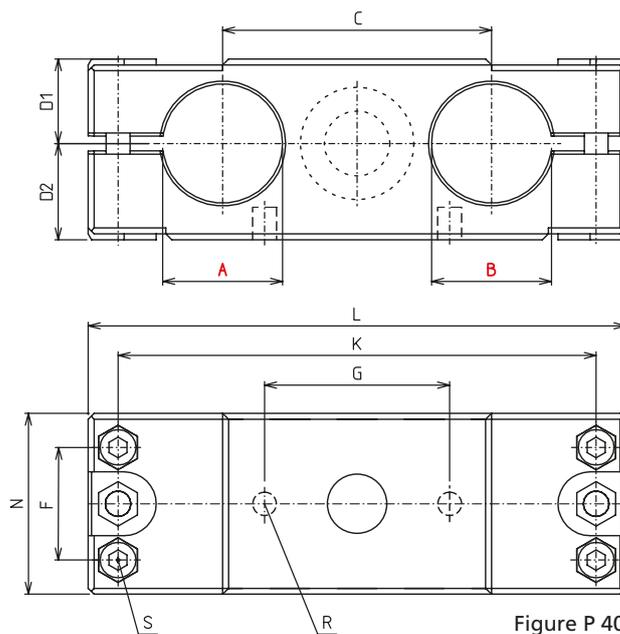
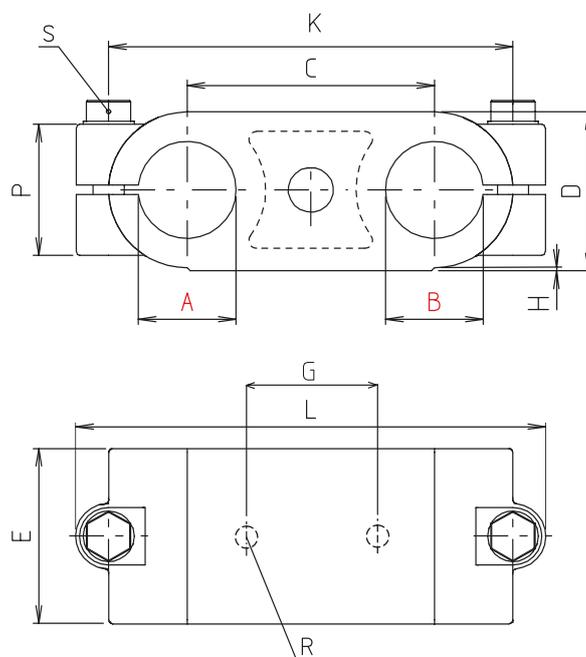

Figure P 40

P - Série industrielle

Code No.	Type	A	B	C	D1	D2	F	G	H	K	L	N	P	R	m [g]	Levier de serrage S Code No.
151200000200	P 12	12,1	12,1	40	13,6	15	-	18	-	68	82	28,5	-	-	140	9020101
151400000200	P 14	14,1	14,1												134	
151600000200	P 16	16,1	16,1												128	
151800000200	P 18	18,1	18,1												120	
154000000200	P 40	40,17	40,17	90	28,5	31,5	38	62	-	160	180	60	-	M8	1307	9022501



P - Série industrielle

Code No.	Type	A	B	C	D	E	G	H	K	L	N	P	R	m [g]	Levier de serrage S Code No.
152000000200	P 20	20,1	20,1	63	41	45	41	1	103	120	45	33	M5	367	9022401
152500000200	P 25	25,1	25,1											330	
153000000200	P 30	30,1	30,1											269	

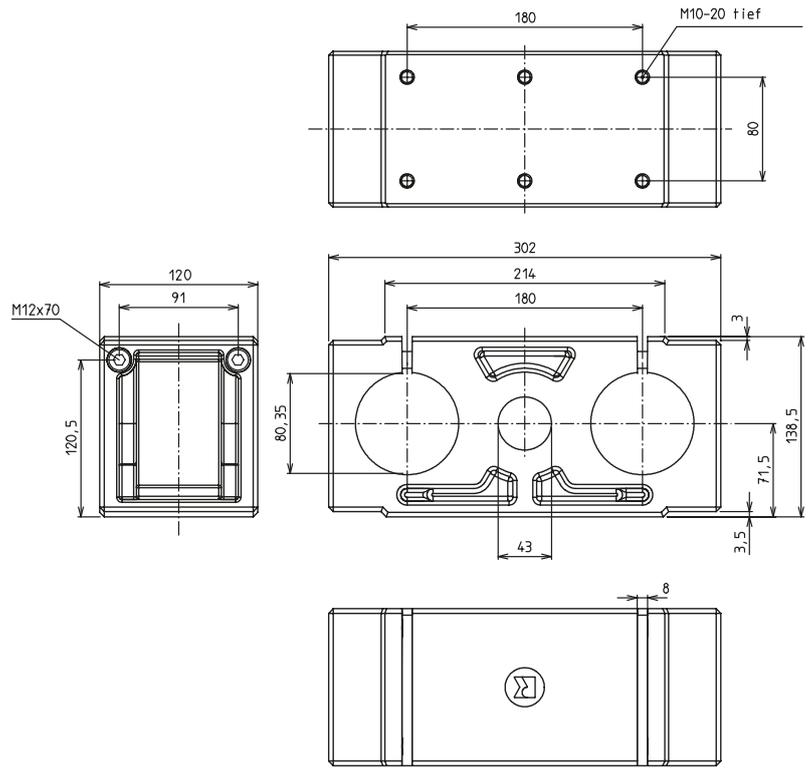

[mm]

P - Série industrie

Code No.	Type	m [g]	Levier de serrage S Code No.
158000000200	P 80	7920	9025601

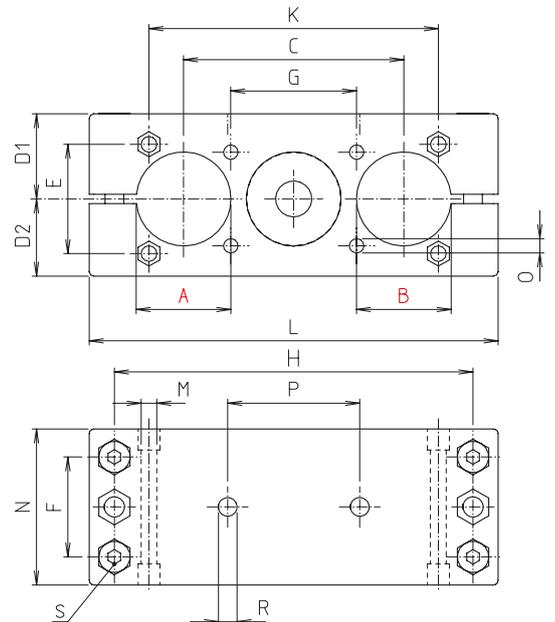

[mm]

PB - Série bloc

Code No.	Type	A	B	C	D1	D2	E	F	G	H	K	L	M	N	O	P	R	X	m [g]	Levier de serrage S Code No.
252000000266	PB 20	20,1	20,1	70	27	25	35	32	40x30	114	92	130	5,3*	50	4,2-10 prof	42	M6	28	733	9021501
253000000266	PB 30	30,1	30,1																622	
254800000266	PB 48	48,2	48,2	100	36,5	35	50	50	46	206	150	206	8,5	72	6,5	62	M8	38	1799	9022801
255000000266	PB 50	50,2	50,2																1794	
256000000266	PB 60	60,3	60,25	130	44	42	60	56	55	216	185	240	8,5	80	6,5	74	M10	45	2727	-

* 20 prof., sans hexagone

Les types 12-18 et 40 ne sont plus disponibles. Ils ont été remplacés par les FS dans le design „industrie“

Solid Clamps – Brides de fixation



Versions:

■ Brides de fixation

Livrable
sur stock

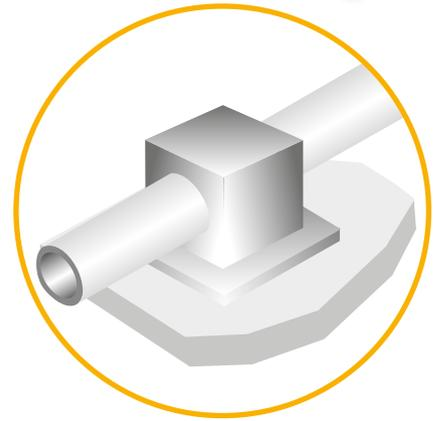

Éléments monoblocs

✓ Pour un montage plus rapide et économique



Série industrie

- Fonte d'aluminium
- Grande diversité
- Éléments monoblocs



Série quad®

- Profilé en aluminium extrudé
- Contrainte de couple maximale
- Surface anodisée haute qualité
- Éléments monoblocs et en plusieurs parties



Éléments en plusieurs parties

✓ Également conçus pour les montages et extensions a posteriori



Série quad®

- Profilé en aluminium extrudé
- Contrainte de couple maximale
- Surface anodisée haute qualité
- Éléments monoblocs et en plusieurs parties



Série bloc

- Fonte d'aluminium
- Contrainte de couple plus élevée
- Contours extérieurs plans
- Éléments en plusieurs parties

Charges admissibles

ATTENTION !

Les valeurs données dans les tableaux ne constituent pas un engagement sur les valeurs ni une garantie de résultat à propos de nos produits.

Il ne s'agit que de valeurs indicatives non contractuelles, qui peuvent dans certains cas ne pas être atteintes, dépendant notamment de divers facteurs liés aux applications, comme la température ou la nature de la surface des tubes.

Couple de serrage des vis:

M6: 10 Nm

M8: 25 Nm

M10: 50 Nm

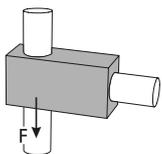

Adhérence F [KN]

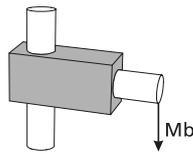

Moment de flexion Mb [Nm]

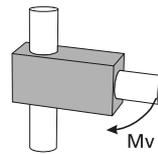

Couple de torsion Mv [Nm]

Pour obtenir ces valeurs, il faut utiliser des rondelles avec les vis de fixation des embases

Talle Type	18			30			40			50			60			80		
	F	Mb	Mv	F	Mb	Mv	F	Mb	Mv	F	Mb	Mv	F	Mb	Mv	F	Mb	Mv
Série industrie																		
FK	1,1	128	21	4,9	200	95	8,9	504	254	11,6	750	1025	9,9	1393	253			
FKR				6,8	429	117	6	1190	152									
FKV				5,2	270	381	3	1247	955									
R				6,8			6											
V				5,2			3											
RH				4,0			6,1			4,9			5,1			6,3		
VH				1,7			2,5			3			4			10		

Talle Type	18			30			40			50			60			80		
	F	Mb	Mv	F	Mb	Mv	F	Mb	Mv	F	Mb	Mv	F	Mb	Mv	F	Mb	Mv
Série bloc																		
FKR				4,3	438	96	2,5	450	700	8,2	1465	260	12,2	1456	255	10	2500	602
FKV				3,5	304	372	1,5	450	320	5,9	937	1250	7,8	1688	1203	20	2500	2250
R				4,3			5,7			9,4			12,2			10		
V				3,5			2,8			5,9			7,9			19		
RH				4,0			6,1			4,9			5,1			6,3		
VH				1,7			2,5			3			4			10		

Talle Type	18			30			40			50			60			80		
	F	Mb	Mv	F	Mb	Mv	F	Mb	Mv	F	Mb	Mv	F	Mb	Mv	F	Mb	Mv
Série quad®																		
R				6,2			7,1			11,8						19,4		
RH				3,1			3,5			5,8						7,5		
V				5			7,4			7,5						20,1		
VH				1,9			4,2			2,6						7,7		
FK				2,5	484	59	4,9	750	89	6,3	1620	159						
FKH				2,7	96	48	3,2	102	62	5,6	230	86						
FKR				6,2	657	90	7,1	786	121	11,9	2146	272				19,4		950
FKRH				3,1	105	47	3,5	110	87	5,8	287	70				7,5		243
FKV				5	590	338	7,4	682	743	7,5	1904	1100				20,1		
FKVH				2,5	109	134	4,2	102	451	2,6	297	563				7,7		

Solid Clamps – Brides de fixation

Raccords tubulaires
parallèles à l'axe

Série industrie

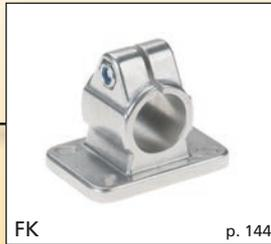

Série bloc



Série quad®

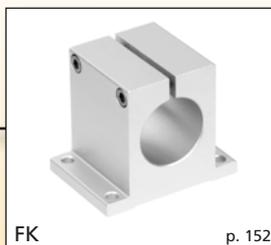

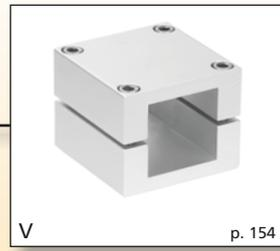
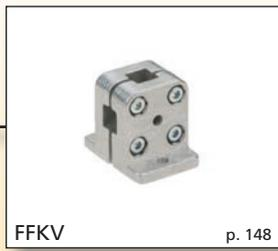

Solid Clamps – Brides de fixation

Principe de commande:

- Vis galvanisées en équipement standard
- Levier de serrage à commander séparément. Livré non monté. Voir dernière colonne du tableau et page 222

Sur demande:

- Vis en acier inoxydable
- En couleur
- Polissage à billes



FK 30-4 - 80
(4 alésages, 20-60 avec trou oblong)



FK 12-30
(2 alésages centrés)

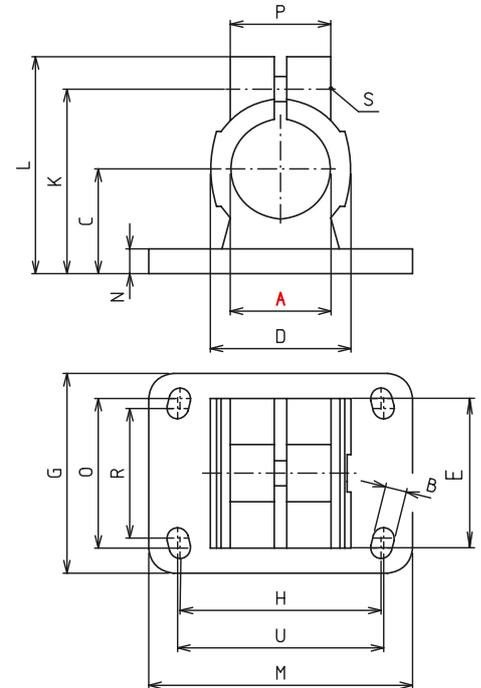

FK - Série industrie

Code No.	Type	A	B	C	D	E	G	H**	K	L	M	N	O*	P	R	U	m [g]	Levier de serrage S Code No.	
12120000020	FK 12	12,1															67	90209	
12140000020	FK 14	14,1															64		
12150000020	FK 15	15,1	6	18	26	32	35	38	32,5	41	50	5	-	23	-	40	62		
12160000020	FK 16	16,1															60		
12180000020	FK 18	18,1															56		
12200000020	FK 20	20,1											-	33	-		202	9022201	
12200100020	FK 20-4	20,1	7	30	40	40	55	53	53	63	78	7	40		35	60	205		
12250000020	FK 25	25,1											-		-		184		
12250100020	FK 25-4	25,1											40		35		188		
	FK 28*	*Avec machon adaptateur R28, voir accessoires page 223																	
12300000020	FK 30	30,1	7	30	40	40	55	53	53	63	78	7	-	33	-	60	162	9022201	
12300100020	FK 30-4	30,1											40		35		166		
12300200020	FK30(32)	30,1															489	90250	
12320000020	FK 32	32,17	9	42	56	60	80	80	74	87	105	10	60	40	52	82	473		
12350000020	FK 35	35,15															449		
12400000020	FK 40	40,17															404		
12400200020	FK40(42)	40,17															703		
12420000020	FK 42	42,22	11	50	66	65	90	98	85	98	128	14	62	45	60	100	682	90251	
12480000020	FK 48	48,22															610		
12500000020	FK 50	50,22															585		
12600000020	FK 60	60,27	11	60	80	80	110	100	107	123	150	15	80	58	74	118	1048	9025301	
12800000020	FK 80	80,35	17,5	80	110	123	164,7	140	140	162,5	180	20	120	82	-	-	2930	9027001	



FKR - Série industrie

Code No.	Type	A	B	C	D	E	G	H	K	L	M	N	R	m [g]	Levier de serrage S Code No
12200003020	FKR 20	20,2	7	30	45	45	75	57	62	52,5	75	10	46	314	9022601
12250003020	FKR 25	25,2												301	
12300003020	FKR 30	30,2												285	
12350003020	FKR 35	35,2	8,5	40	60	60	100	76	75	70	100	10	57	569	9022901
12400003020	FKR 40	40,2												545	

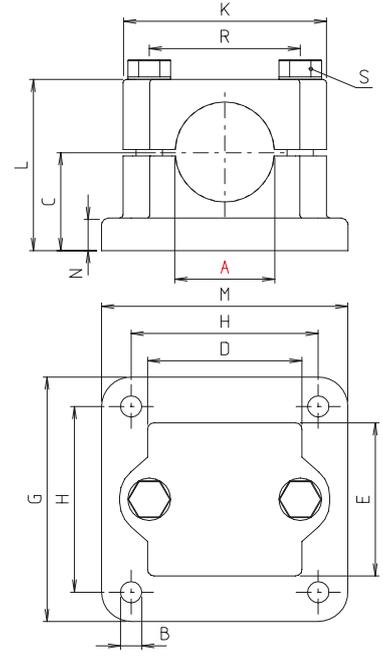

[mm]



FKV - Série industrie

Code No.	Type	A	B	C	D	E	G	H	K	L	M	N	R	m [g]	Levier de serrage S Code No
12200005020	FKV 20	20,2	7	30	45	45	75	57	62	52,5	75	10	46	302	9022601
12250005020	FKV 25	25,3												292	
12300005020	FKV 30	30,3												273	
12350005020	FKV 35	35,4	8,5	40	60	60	100	76	75	70	100	10	57	555	9022901
12400005020	FKV 40	40,4												530	

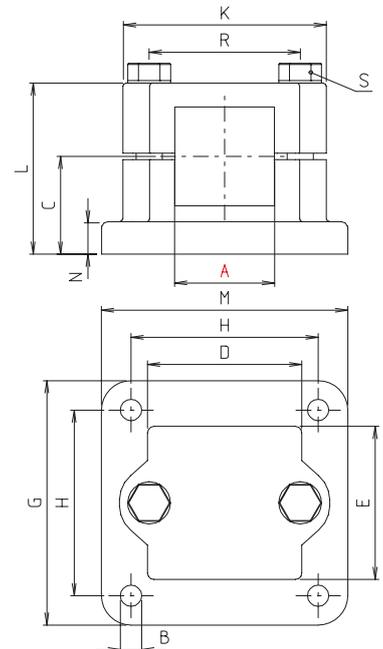

[mm]

Solid Clamps – Brides de fixation

Principe de commande:

- Vis galvanisées en équipement standard
- Levier de serrage à commander séparément. Livré non monté. Voir dernière colonne du tableau et page 222

Sur demande:

- Vis en acier inoxydable
- En couleur
- Polissage à billes

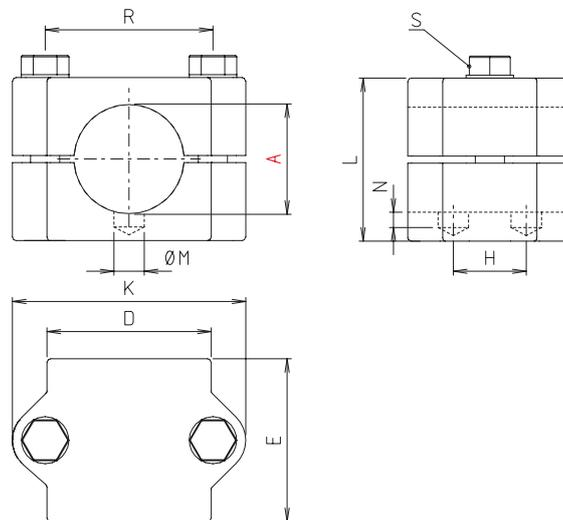

R - Série industrie

[mm]

Code No.	Type	A	D	E	H	K	L	M	N	R	m [g]	Levier de serrage S Code No.
12200007020	R 20	20,1	45	45	20	62	45	10	3	46	211	9022501
12250007020	R 25	25,2									210	
12300007020	R 30	30,2									194	
12350007020	R 35	35,2	60	60	26	75	60	14	5,5	57	376	9022801
12400007020	R 40	40,2									360	

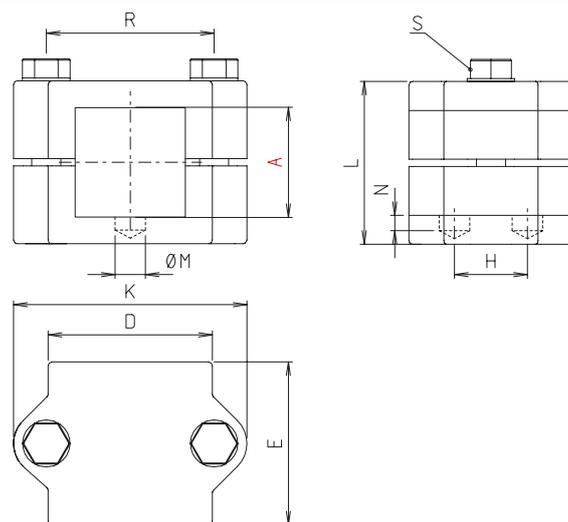

V - Série industrie

[mm]

Code No.	Type	A	D	E	H	K	L	M	N	R	m [g]	Levier de serrage S Code No.
12200008020	V 20	20,3	45	45	20	62	45	10	3	46	202	9022501
12250008020	V 25	25,3									197	
12300008020	V 30	30,3									187	
12350008020	V 35	35,4	60	60	26	75	60	14	5,5	57	361	9022801
12400008020	V 40	40,4									334	

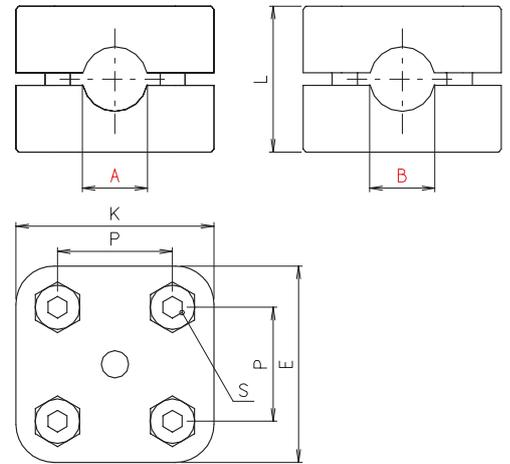

RRW - Série bloc

[mm]

Code No.	Type	A	B	E	K	L	P	S	m [g]
290800040266	RRW 8*	8	8	31	31	23	18	M4x18	47
291000040266	RRW 10	10	10						46

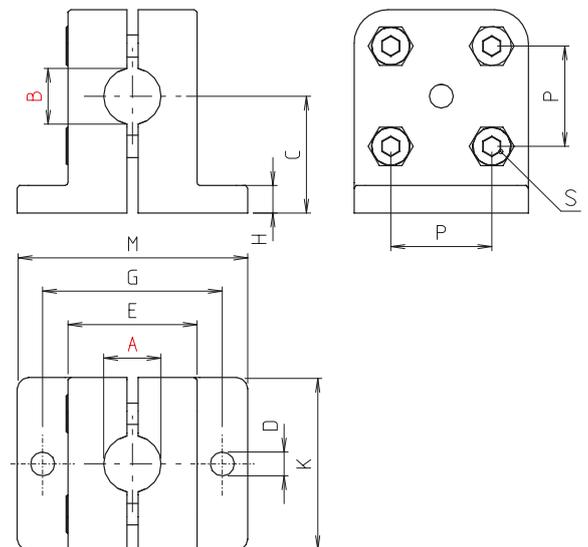

FFKR - Série bloc

[mm]

Code No.	Type	A	B	C	D	E	G	H	K	L	M	P	S	m [g]
290800020266	FFKR 8*	8	8	21	4	23	32	5	31	36	41	18	M4x18	62
291000020266	FFKR 10	10	10											58

* Ø 8 réduit à l'aide d'une douille de serrage

Solid Clamps – Brides de fixation

Principe de commande:

- Vis galvanisées en équipement standard
- Levier de serrage à commander séparément. Livré non monté. Voir dernière colonne du tableau et page 222

Sur demande:

- Vis en acier inoxydable
- En couleur
- Polissage à billes

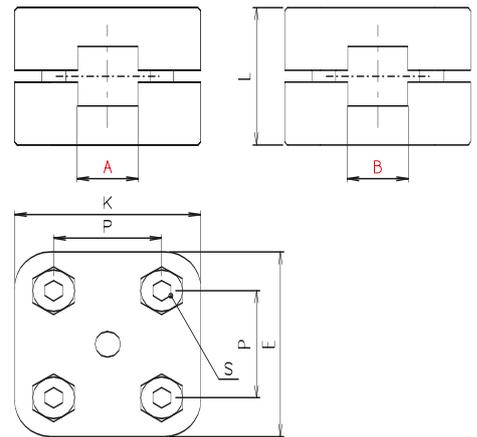

VVW - Série bloc

[mm]

Code No.	Type	A	B	E	K	L	P	S	m [g]
291000050266	VVW 10	10	10	31	31	23	18	M4x18	42

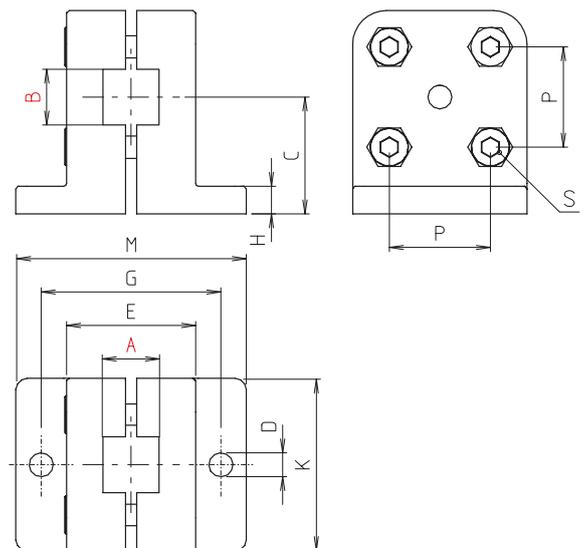

FFKV - Série bloc

[mm]

Code No.	Type	A	B	C	D	E	G	H	K	L	M	P	S	m [g]
291000030266	FFKV 10	10	10	21	4	23	32	5	31	36	41	18	M4x18	5

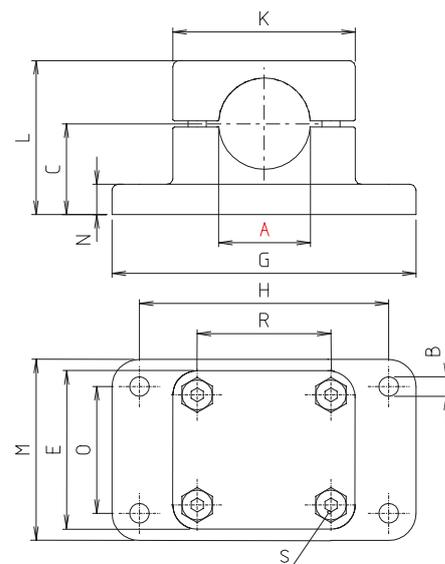

FKR - Série bloc

[mm]

Code No.	Type	A	B	C	E	G	H	K	L	M	N	O	R	m [g]	Levier de serrage S Code No
22300003026	FKR 30	30,2	7	30	60	100	82	60	54	60	10	42	44	349	9021501
22350003026	FKR 35	35,4	7	40	70	110	92	70	73	71	12	52	53	552	
22400003026	FKR 40	40,2	9	50	86	125	98	86	90	125	12	98	65	521	9023001
22420003026	FKR 42	42,3												1226	
22450003026	FKR 45	45,3												1222	
22480003026	FKR 48	48,3												1191	
22500003026	FKR 50	50,3												1190	
22600003026	FKR 60	60,4	8,5	60	100	144	122	100	105	100	16	78	78	1489	9023101
22800003026	FKR 80	80,5	11	80	130	200	170	130	141	130	20	100	100	4050	9024601

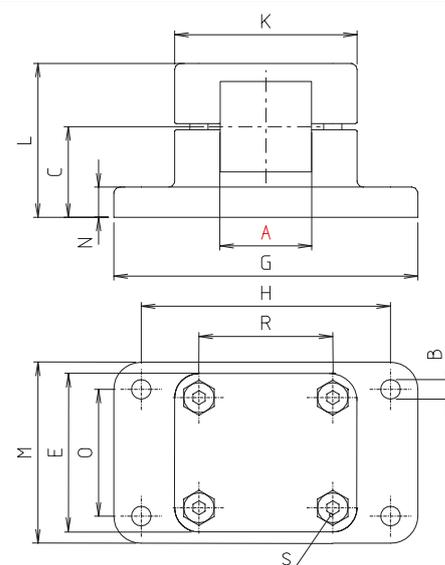

FKV - Série bloc

[mm]

Code No.	Type	A	B	C	E	G	H	K	L	M	N	O	R	m [g]	Levier de serrage S Code No
22300005026	FKV 30	30,3	7	30	60	100	82	60	54	60	10	42	44	341	9021501
22400005026	FKV 40	40,4	7	42	70	110	92	70	73	70	12	52	53	511	9021701
22500005026	FKV 50	50,5	9	50	86	125	98	86	90	125	12	98	65	1124	9023001
22600005026	FKV 60	60,6	9	60	100	144	122	100	105	100	16	78	78	1428	9023101
22800005026	FKV 80	80,7	11	80	130	200	170	130	141	130	20	100	100	3878	9024601

Solid Clamps – Brides de fixation

Principe de commande:

- Vis galvanisées en équipement standard
- Levier de serrage à commander séparément. Livré non monté. Voir dernière colonne du tableau et page 222

Sur demande:

- Vis en acier inoxydable
- En couleur
- Polissage à billes

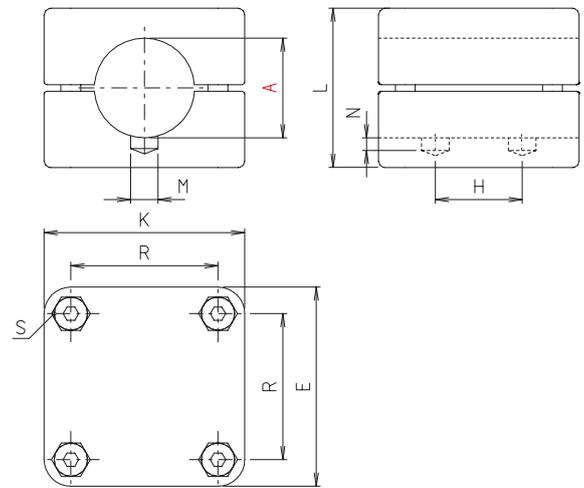

R - Série bloc

[mm]

Code No.	Type	A	E	H	K	L	M	N	R	m [g]	Levier de serrage S Code No.
22300007026	R 30	30,1	60	26	60	48	11	5,5	44	256	9021401
22320007026	R 32	32,2	70	26	70	62	14	6	53	420	9021601
22350007026	R 35	35,2								410	
22400007026	R 40	40,2	86	50	86	79	14	8,5	65	395	9022901
22420007026	R 42	42,3								914	
22450007026	R 45	45,3								870	
22480007026	R 48	48,3								878	
22500007026	R 50	50,3	100	50	100	90	14	9	78	873	9023001
22600007026	R 60	60,4								1136	
22800007026	R 80	80,5	130	70	130	122	8,5	5,5	100	2560	9024601

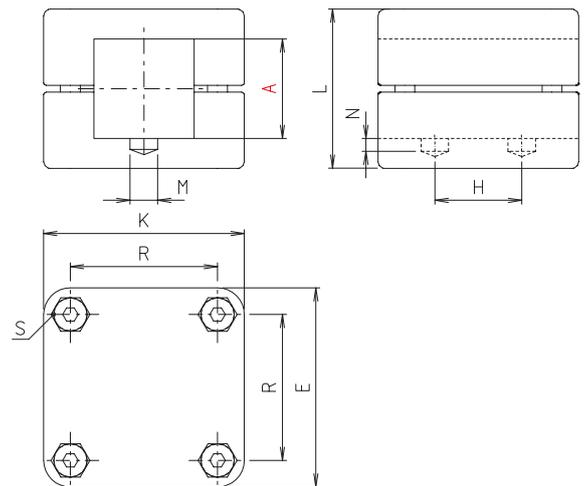

V - Série bloc

[mm]

Code No.	Type	A	E	H	K	L	M	N	R	m [g]	Levier de serrage S Code No.							
22300008026	V 30	30,3	60	26	60	48	11	5,5	44	249	9021401							
22350008026	V 35	35,4	70	26	70	62	14	6	53	390	9021601							
22400008026	V 40	40,4								404								
22500008026	V 50	50,5	86	50	86	79	14	8,5	65	811	9022901							
22600008026	V 60	60,6								1064	9023001							
22800008026	V 80	80,7								130	70	130	122	8,5	5,5	100	2380	9024601

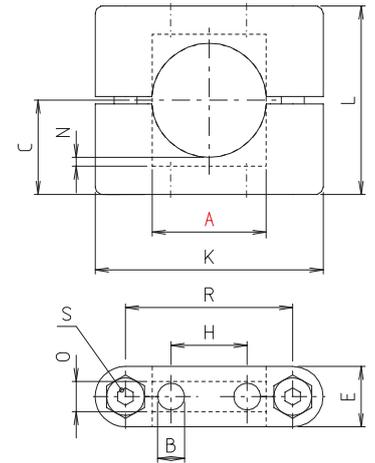

[mm]

RH - Série bloc

Code No.	Type	A	B	C	E	H	K	L	N	O	R	m [g]	Levier de serrage S Code No.
22200002026	RH 20	20,1										92	9021401
22250002026	RH 25	25,1	5,1	25	16	20	60	50	5	8,1	44	84	
22300002026	RH 30	30,1										72	
22350002026	RH 35	35,2										198	9022801
22400002026	RH 40	40,2	6,5	34	20	26	75	68	7	10,1	55	192	
22420002026	RH 42	42,3										256	9022901
22450002026	RH 45	45,3										242	
22480002026	RH 48	48,3	6,5	40	20	26	85	79	7,5	10,1	65	239	
22500002026	RH 50	50,3										236	
22600002026	RH 60	60,4	6,5	45	22	26	100	90	6	10,1	78	318	9022301
22800002026	RH 80	80,5	8,5	61	30	50	130	122	11	13,1	100	775	9024601

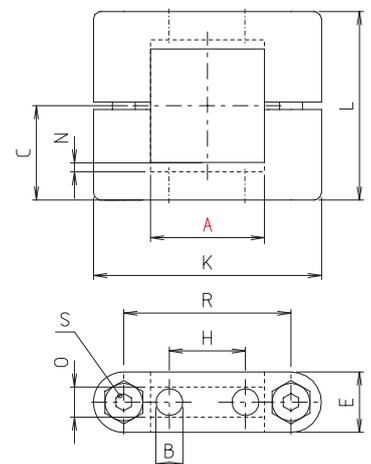

[mm]

VH - Série bloc

Code No.	Type	A	B	C	E	H	K	L	N	O	R	m [g]	Levier de serrage S Code No.
22250004026	VH 25	25,3										85	9021401
22300004026	VH 30	30,3	5,1	25	16	20	60	50	5	8,1	44	72	
22350004026	VH 35	35,4										184	9022801
22400004026	VH 40	40,4	6,5	34	20	26	75	68	7	10,1	55	172	
22500004026	VH 50	50,5										217	9022901
22600004026	VH 60	60,6	6,5	40	20	26	85	79	7,5	10,1	65	286	9023001
22800004026	VH 80	80,9	8,5	61	30	50	130	122	11	13,1	100	698	9024601

Solid Clamps – Brides de fixation

Principe de commande:

- Quad® avec vis en acier inoxydable
- Levier de serrage à commander séparément. Livré non monté. Voir dernière colonne du tableau et page 222

Sur demande:

- Anodisé noir

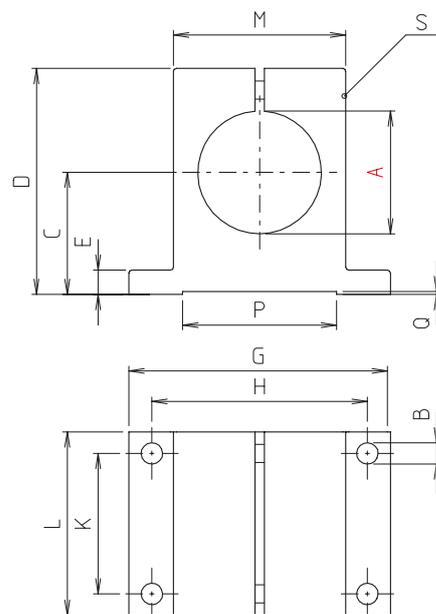

FK - Série quad®

[mm]

Code No.	Type	A	B	C	D	E	G	H	K	L	M	P	Q	m [g]	Levier de serrage S Code No.
52300000030	FK 30	30,1	7	30	58	6	70	56	36	50	42	35	1	246	9300101
52400000030	FK 40	40,1	7	40	74	8	85	70	46	60	56	50	1	490	9301401
52500000030	FK 50	50,2	9	50	92	10	110	90	50	77	70	60	1	911	9300401
52600000030	FK 60	60,2	9	60	112,5	12	137	110	75	100	85	71	2	2000	9022801

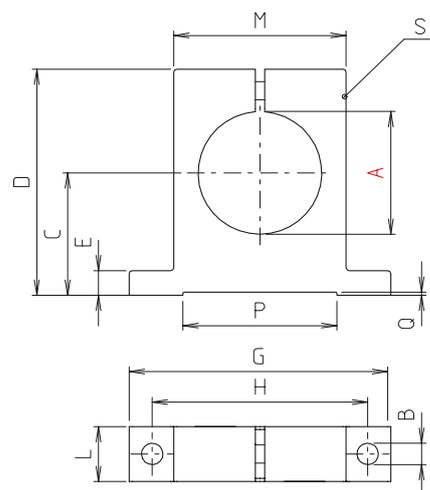

FKH - Série quad®

[mm]

Code No.	Type	A	B	C	D	E	G	H	L	M	P	Q	m [g]	Levier de serrage S Code No.
52300011030	FKH 30	30,1	7	30	58	6	70	56	16	42	35	1	80	9300101
52400011030	FKH 40	40,1	7	40	74	8	85	70	18	56	50	1	147	9301401
52500011030	FKH 50	50,2	9	50	92	10	110	90	20	70	60	1	262	9300401
52600011030	FKH 60	60,2	9	60	112,5	12	137	110	20	85	71	2	460	9022801

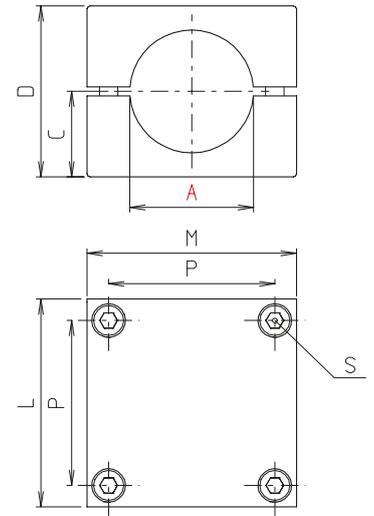
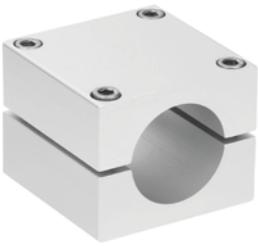
R - Série quad®

[mm]

Code No.	Type	A	C	D	L	M	P	m [g]	Levier de serrage S Code No.
52300007030	R 30	30,1	21	42	56	56	42	252	9300101
52400007030	R 40	40,2	28	56	68	68	54	459	9301401
52500007030	R 50	50,3	35	70	85	85	67	927	9300401
52600007030	R 60	60,3	48,5	97	105	105	85	–	9022801
52800007030	R 80	80,6	56	112	126	126	100	3000	9300801

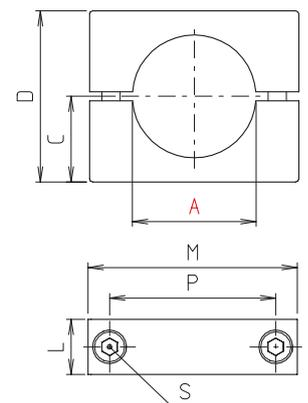
RH - Série quad®

[mm]

Code No.	Type	A	C	D	L	M	P	m [g]	Levier de serrage S Code No.
52300002030	RH 30	30,1	21	42	16	56	42	74	9300101
52400002030	RH 40	40,2	28	56	18	68	54	122	9301401
52500002030	RH 50	50,3	35	70	20	85	67	229	9300401
52600002030	RH 60	60,3	48,5	97	22	105	85	–	9022801
52800002030	RH 80	80,6	56	112	24	126	100	608	9300801

Solid Clamps – Brides de fixation

Principe de commande:

- Quad® avec vis en acier inoxydable
- Levier de serrage à commander séparément. Livré non monté. Voir dernière colonne du tableau et page 222

Sur demande:

- Anodisé noir

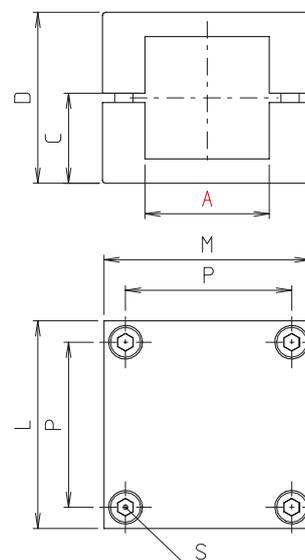

V - Série quad®

[mm]

Code No.	Type	A	C	D	L	M	P	m [g]	Levier de serrage S Code No.
52300008030	V 30	30,2	21	42	56	56	42	220	9300101
52400008030	V 40	40,3	28	56	68	68	54	401	9301401
52500008030	V 50	50,4	35	70	85	85	67	785	9300401
52600008030	V 60	60,3	48,5	97	105	105	85	–	9022801
52800008030	V 80	80,4	56	112	126	126	100	2540	9300801

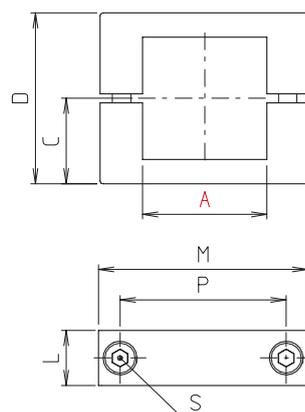

VH - Série quad®

[mm]

Code No.	Type	A	C	D	L	M	P	m [g]	Levier de serrage S Code No.
52300004030	VH 30	30,2	21	42	16	56	42	65	9300101
52400004030	VH 40	40,3	28	56	18	68	54	109	9301401
52500004030	VH 50	50,4	35	70	20	85	67	197	9300401
52600004030	VH 60	60,4	48,5	97	22	105	85	–	9022801
52800004030	VH 80	80,4	56	112	24	126	100	522	9300801

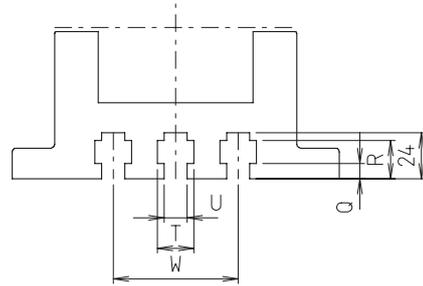

seulement FKR 60, 80

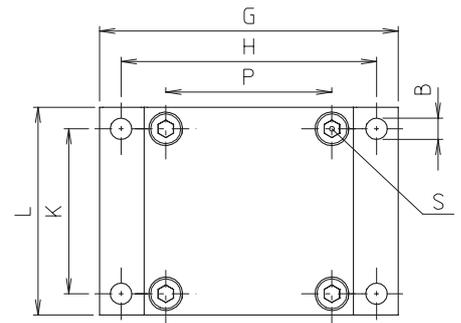
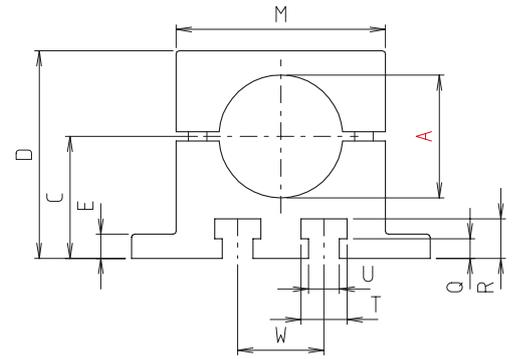

FKR - Série quad®

[mm]

Code No.	Type	A	B	C	D	E	G	H	K	L	M	Q	R	T	U	W	m [g]	Levier de serrage S Code No.
52300003030	FKR 30	30,1	7	30	51	6	84	70	40	56	56	4,5	9	10	6	20	329	9300101
52400003030	FKR 40	40,2	7	40	68	8	97	83	54	68	68	6,5	13	15	10	28	586	9301401
52500003030	FKR 50	50,3	9	50	85	10	125	105	65	85	85	7	14	20	10	30	1204	9300401
52600003030	FKR 60	60,3	9	62,5	111	12	145	120	80	105	105	7	14	20	10	65	-	9022801
52800003030	FKR 80	80,4	11	80	136	16	170	148	80	126	126	8	20	19	12	65	3876	9300801

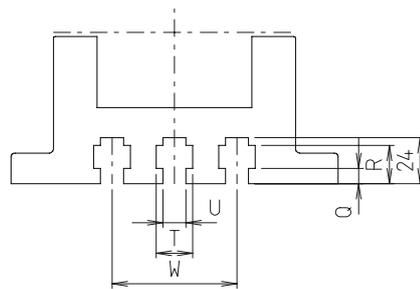

seulement FKR 60, 80

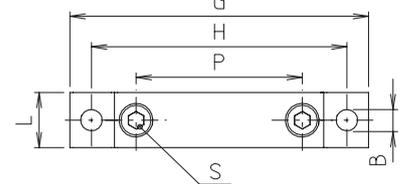
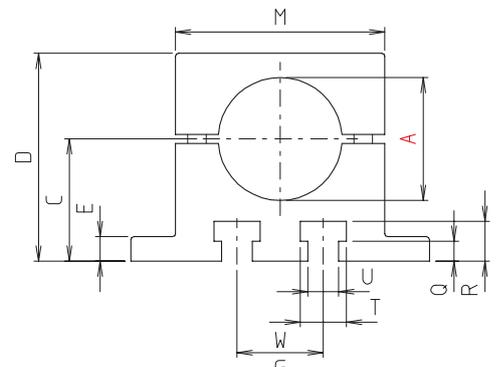

FKRH - Série quad®

[mm]

Code No.	Type	A	B	C	D	E	G	H	L	M	Q	R	T	U	W	m [g]	Levier de serrage S Code No.
52300009030	FKRH 30	30,1	7	30	51	6	84	70	16	56	4,5	9	10	6	20	96	9300101
52400009030	FKRH 40	40,2	7	40	68	8	97	83	18	68	6,5	13	15	10	28	158	9301401
52500009030	FKRH 50	50,3	9	50	85	10	125	105	20	85	7	14	20	10	30	293	9300401
52600009030	FKRH 60	60,3	9	62,5	111	12	145	120	22	105	7	14	20	10	65	-	9022801
52800009030	FKRH 80	80,4	11	80	136	16	170	148	24	126	8	20	19	12	65	783	9300801

Solid Clamps – Brides de fixation

Principe de commande:

- Quad® avec vis en acier inoxydable
- Levier de serrage à commander séparément. Livré non monté. Voir dernière colonne du tableau et page 222

Sur demande:

- Anodisé noir

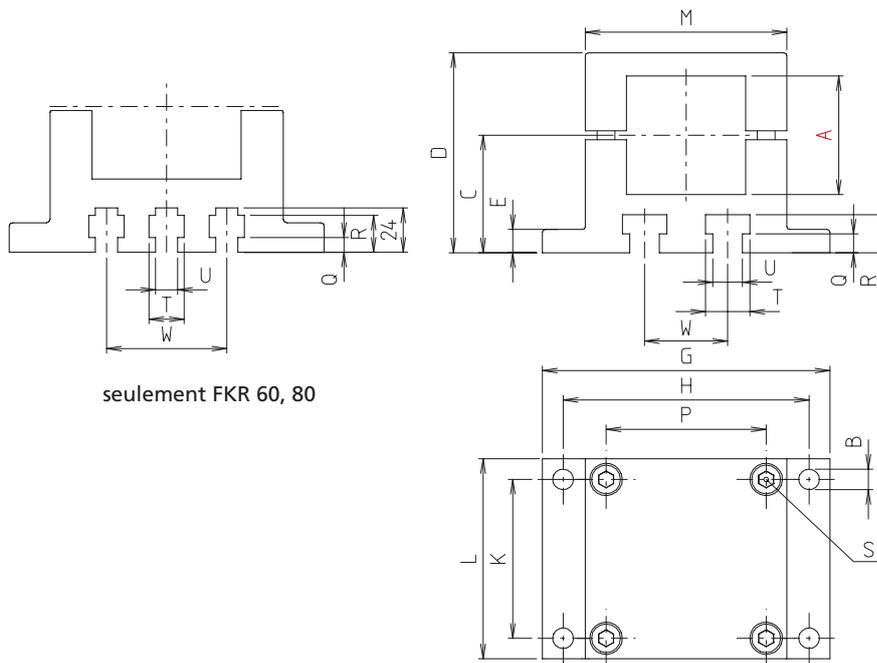

FKV - Série quad®

[mm]

Code No.	Type	A	B	C	D	E	G	H	K	L	M	P	Q	R	T	U	W	m [g]	Levier de serrage S Code No
52300005030	FKV 30	30,2	7	30	51	6	84	70	40	56	56	40	4,5	9	10	6	20	303	9300101
52400005030	FKV 40	40,3	7	40	68	8	97	83	54	68	68	54	6,5	13	15	10	28	525	9301401
52500005030	FKV 50	50,4	9	50	85	10	125	105	65	85	85	65	7	14	20	10	30	1065	9300401
52600005030	FKV 60	60,3	9	62,5	111	12	145	120	80	105	105	80	7	14	20	10	65	-	9022801
52800005030	FKV 80	80,4	11	80	136	16	170	148	100	126	126	100	8	20	19	12	65	3440	9300801

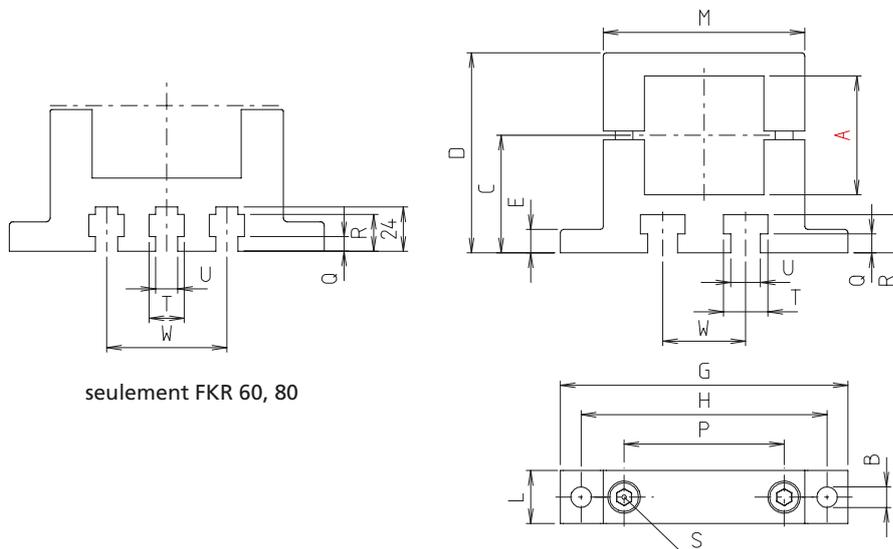

FKVH - Série quad®

[mm]

Code No.	Type	A	B	C	D	E	G	H	L	M	P	Q	R	T	U	W	m [g]	Levier de serrage S Code No
52300010030	FKVH 30	30,2	7	30	51	6	84	70	16	56	40	4,5	9	10	6	20	86	9300101
52400010030	FKVH 40	40,3	7	40	68	8	97	83	18	68	54	6,5	13	15	10	28	141	9301401
52500010030	FKVH 50	50,4	9	50	85	10	125	105	20	85	65	7	14	20	10	30	259	9300401
52600010030	FKVH 60	60,4	9	62,5	111	12	145	120	22	105	80	7	14	20	10	65	-	9022801
52800010030	FKVH 80	80,4	11	80	136	16	170	148	24	126	100	8	20	19	12	65	690	9300801

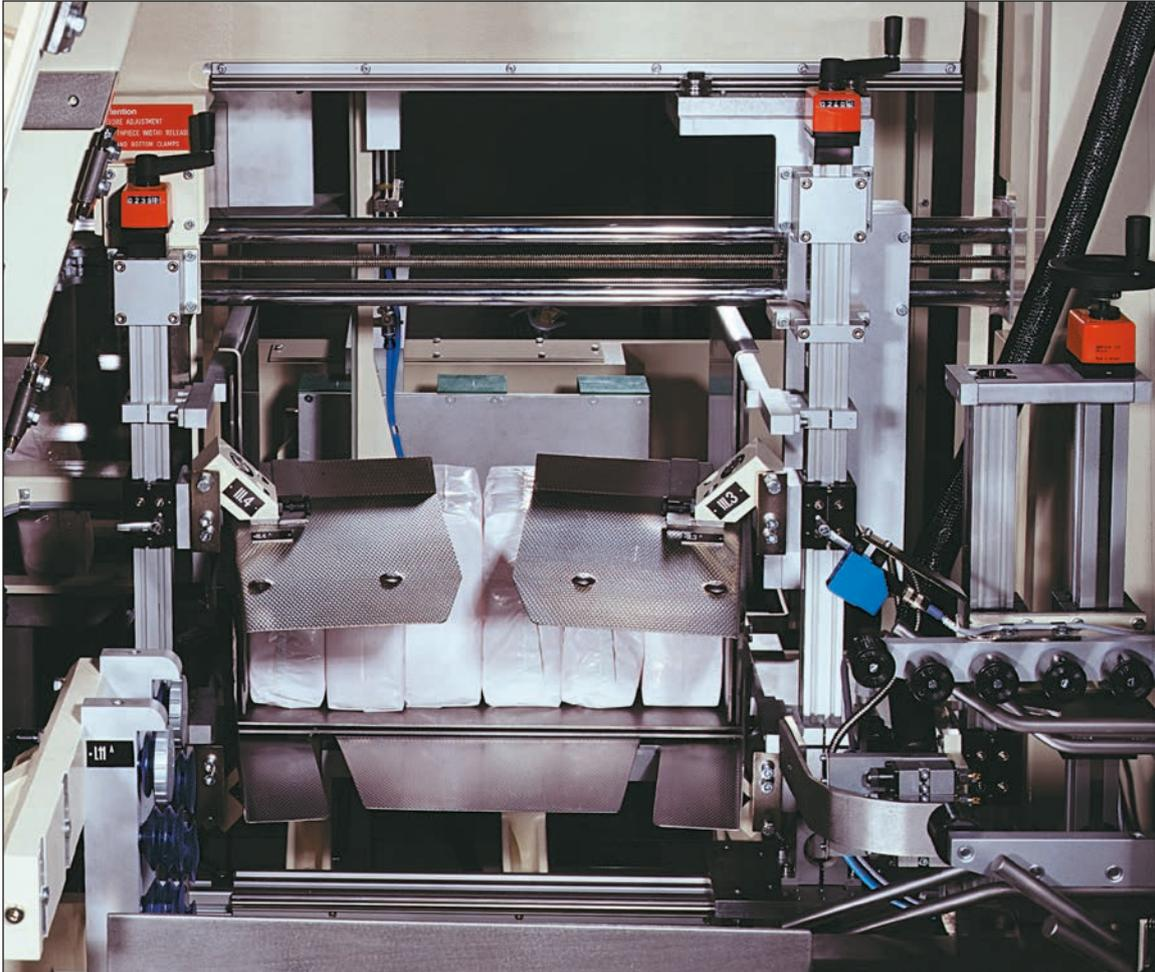

Fixation simple d'unités linéaires (pour le réglage du format) sur une machine à emballer.



Versions:

■ Raccords à collier

Livrable
sur stock

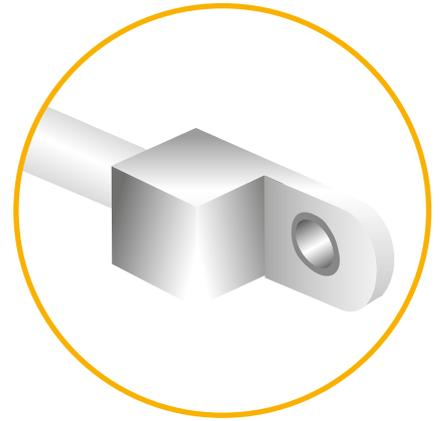

Éléments monoblocs

✓ Pour un montage plus rapide et économique



Série industrie

- Fonte d'aluminium
- Grande diversité
- Éléments monoblocs



Éléments en plusieurs parties

✓ Également conçus pour les montages et extensions a posteriori



Série bloc

- Fonte d'aluminium
- Contrainte de couple plus élevée
- Contours extérieurs plans
- Éléments en plusieurs parties

Charges admissibles

ATTENTION !

Les valeurs données dans les tableaux ne constituent pas un engagement sur les valeurs ni une garantie de résultat à propos de nos produits.

Il ne s'agit que de valeurs indicatives non contractuelles, qui peuvent dans certains cas ne pas être atteintes, dépendant notamment de divers facteurs liés aux applications, comme la température ou la nature de la surface des tubes.

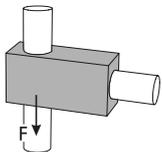

Adhérence F [KN]

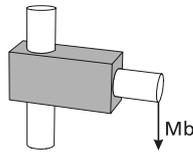

Moment de flexion Mb [Nm]

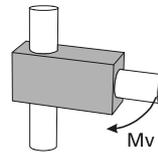

Couple de torsion Mv [Nm]

Couple de serrage des vis:

M6: 10 Nm

M8: 25 Nm

M10: 50 Nm

Taille Type	10			18			30			40			50			60		
	F	Mb	Mv	F	Mb	Mv	F	Mb	Mv	F	Mb	Mv	F	Mb	Mv	F	Mb	Mv
Série industrie																		
LW				2,7	38	15	6	133	85	5,8	264	138	12	274	358			
LP				3,6	28	9	4,9	91	94	6	267	181	12,1	332	387			
LQ				2,7	28	15	4,9	83	94	5,8	231	138	12,1	346	133			
LF					40	50		110	101		562	635		349	377			

Taille Type	10			18			30			40			50			60		
	F	Mb	Mv	F	Mb	Mv	F	Mb	Mv	F	Mb	Mv	F	Mb	Mv	F	Mb	Mv
Série bloc																		
LWR										7,1	397	107						
LWV										3,2	333	287						
LPR										7,1	598	107						
LPV										3,2	405	438						
LQR										7,1	593	107						
LQV										3,2	738	653						
LF																		

Solid Clamps – Raccords à collier

Raccords tubulaires articulés

Série industrie



LWR

p. 162



LPR

p. 163

Série bloc



LWR

p. 166



LPR

p. 166



Solid Clamps – Raccords à collier

Principe de commande:

- Vis galvanisées en équipement standard
- Levier de serrage à commander séparément. Livré non monté. Voir dernière colonne du tableau et page 222

Sur demande:

- Vis en acier inoxydable
- En couleur
- Polissage à billes

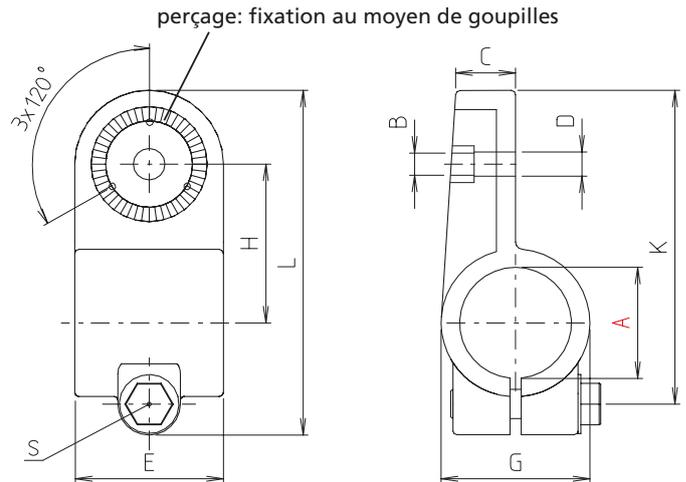

perçage: fixation au moyen de goupilles
denture à 15°, à l'intérieur



Type LW 12-18



Type LW 20-60

LW - Série industrie

[mm]

Code No.	Type	A	B	C	D	E	G	H	K	L	P	m [g]	Levier de serrage S Code No.
17120000020	LW 12	12,1	M6	10,5	7,5	30	26	27	51,5	64,5	21	62	90210
17140000020	LW 14	14,1										59	
17160000020	LW 16	16,1										56	
17180000020	LW 18	18,1										52	
17200000020	LW 20	20	M8	16	7	40	40	43	85	93	33	169	9022401
17250000020	LW 25	25,1			9							150	
17300000020	LW 30	30,1			131								
17320000020	LW 32	32,2	M10	22	9	56	56	60	116	128	48	428	9024301
17350000020	LW 35	35,2			11							400	
17400000020	LW 40	40,2			366								
17420000020	LW 42	42,2	M10	25	11	66	66	70	136	148	58	586	9024401
17450000020	LW 45	45,2										547	
17480000020	LW 48	48,2										519	
17500000020	LW 50	50,2										488	
17600000020	LW 60	60,2	M12	30	13,5	80	80	85	165	178	68	820	9024401

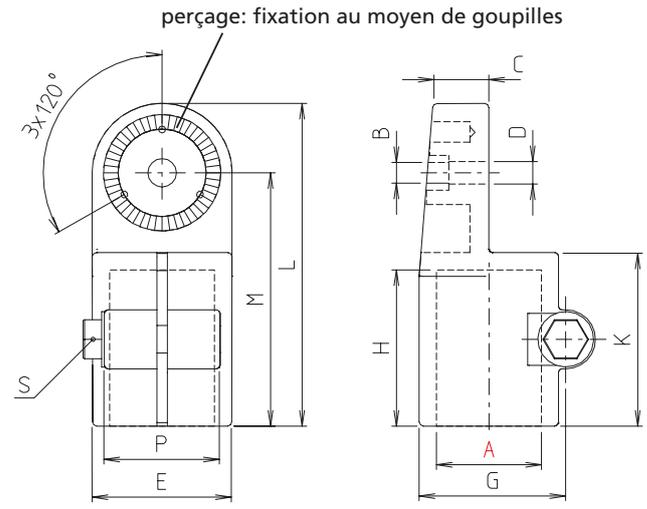

denture à 15°, à l'intérieur



Type LP 12-18



Type LP 20-60

LP - Série industrie

[mm]

Code No.	Type	A	B	C	D	E	G	H	K	L	M	P	m [g]	Levier de serrage S Code No.
17120001020	LP 12	12,1	M6	10,5	7,5	26	29,4	25	30	57	44	21	62	90210
17140001020	LP 14	14,1											59	
17160001020	LP 16	16,1											56	
17180001020	LP 18	18,1											52	
17200001020	LP 20	20	M8	16	9	40	40	45	50	93	73	33	198	9022401
17250001020	LP 25	25,1											179	
17300001020	LP 30	30,1											150	
17320001020	LP 32	32,2	M10	22	11	56	56	60	68	128	100	48	498	9024301
17350001020	LP 35	35,2											460	
17400001020	LP 40	40,2											410	
17420001020	LP 42	42,2											690	
17450001020	LP 45	45,2	M10	25	11	66	66	70	78	148	115	58	653	9024401
17480001020	LP 48	48,2											609	
17500001020	LP 50	50,2											586	
17600001020	LP 60	60,2											940	

Solid Clamps – Raccords à collier

Principe de commande:

- Vis galvanisées en équipement standard
- Levier de serrage à commander séparément. Livré non monté. Voir dernière colonne du tableau et page 222

Sur demande:

- Vis en acier inoxydable
- En couleur
- Polissage à billes

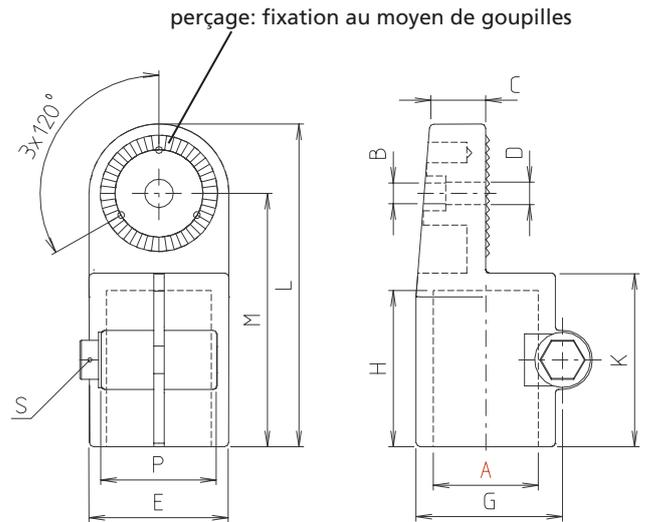

denture à 15°, à l'extérieur



Type LPZ 12-18



Type LPZ 20-60

LPZ - Série industrie

[mm]

Code No.	Type	A	B	C	D	E	G	H	K	L	M	P	m [g]	Levier de serrage S Code No.
17120010020	LPZ 12	12,1	M6	10,5	7,5	26	29,4	25	30	57	44	21	62	90210
17140010020	LPZ 14	14,1											59	
17160010020	LPZ 16	16,1											56	
17180010020	LPZ 18	18,1											52	
17200010020	LPZ 20	20	M8	16	9	40	40	45	50	93	73	33	198	9022401
17250010020	LPZ 25	25,1											179	
17300010020	LPZ 30	30,1											150	
17320010020	LPZ 32	32,2	M10	22	11	56	56	60	68	128	100	48	498	9024301
17350010020	LPZ 35	35,2											460	
17400010020	LPZ 40	40,2											410	
17420010020	LPZ 42	42,2											690	
17450010020	LPZ 45	45,2	M10	25	11	66	66	70	78	148	115	58	653	9024401
17480010020	LPZ 48	48,2											609	
17500010020	LPZ 50	50,2											586	
17600010020	LPZ 60	60,2											940	



Type LQ 20-50

LQ - Série industrie

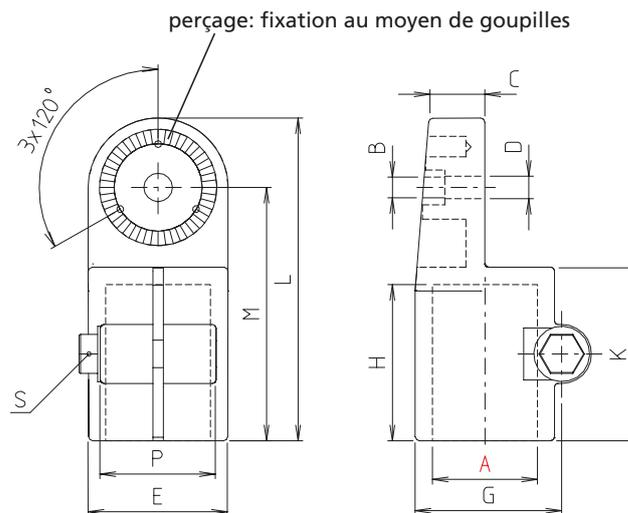

denture à 15°, à l'intérieur

[mm]

Code No.	Type	A	B	C	D	E	G	H	K	L	P	m [g]	Levier de serrage S Code No.
17200003020	LQ 20	20	M8	16	9	45	40	43	85	93	33	102	9022401
17250003020	LQ 25	25										120	
17300003020	LQ 30	30,1										145	
17320003020	LQ 32	32,2	M10	22	11	60	56	60	116	128	48	470	9024301
17350003020	LQ 35	35,2										421	
17400003020	LQ 40	40,2										375	
17420003020	LQ 42	42	M10	25	11	70	66	70	136	148	58	517	9024401
17450003020	LQ 45	45										534	
17480003020	LQ 48	48,2										553	
17500003020	LQ 50	50,2										536	



Type LF 18



Type LF 30-50

LF - Série industrie

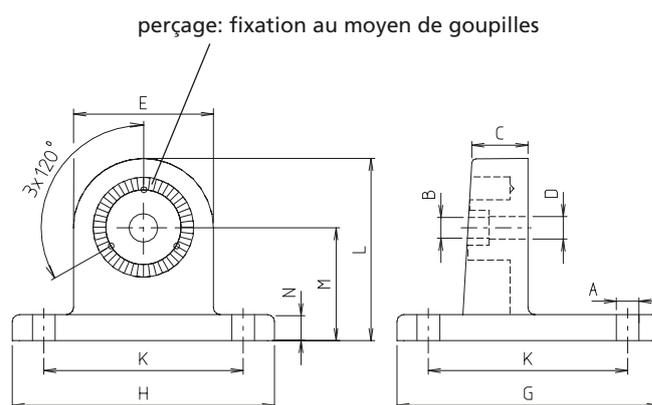

denture à 15°, à l'intérieur

[mm]

Code No.	Type	A	B	C	D	E	G	H	K	L	M	N	m [g]
1718000202	LF 18	5,3	M6	13	7	25	50	35	38-40	32,5	20	5	38
1730000202	LF 30	6,5	M8	16	9	40	75	75	57	52,5	33	7,5	151
1740000202	LF 40	8,5	M10	22	11	56	100	100	76	72	44	10	375
1750000202	LF 50	8,5		25		66	125	125	98	85	52	12	582

Solid Clamps – Raccords à collier

Principe de commande:

- Vis galvanisées en équipement standard
- Levier de serrage à commander séparément. Livré non monté. Voir dernière colonne du tableau et page 222

Sur demande:

- Vis en acier inoxydable
- En couleur
- Polissage à billes

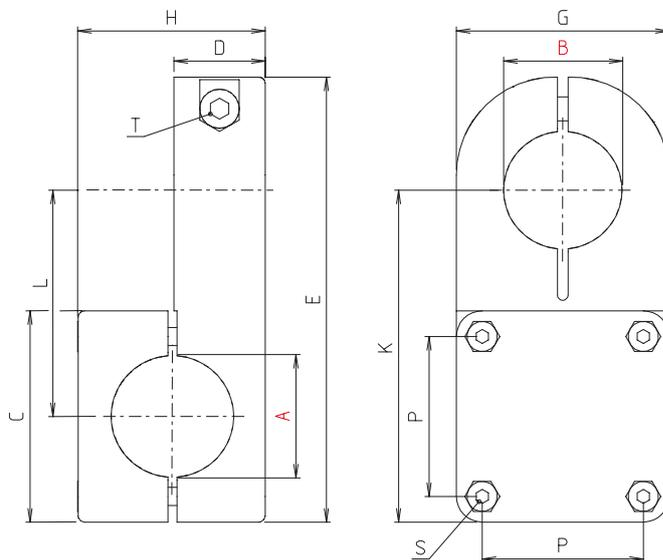

LWR - Série bloc

[mm]

Code No.	Type	A	B	C	D	E	G	H	K	L	P	m [g]	S	T
													Levier de serrage	Code No.
274000040266	LWR 40	40,2	40,2	70	30	146	70	62	110	75	55	654	9021601	9022601

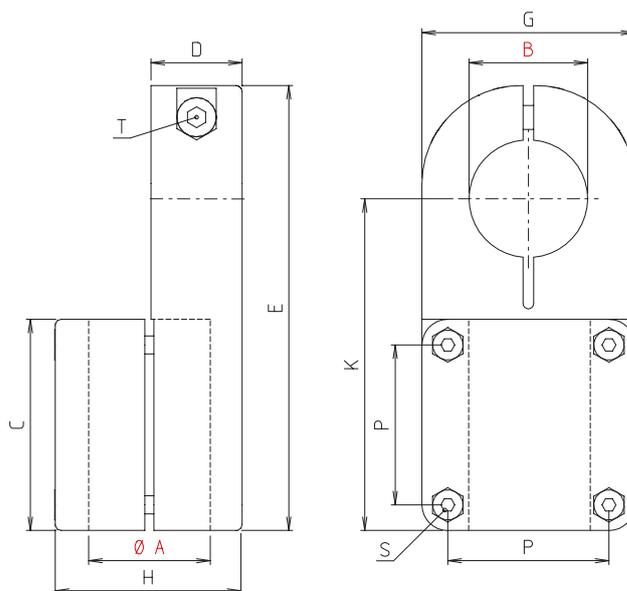

LPR - Série bloc

[mm]

Code No.	Type	A	B	C	D	E	G	H	K	P	m [g]	S	T
												Levier de serrage	Code No.
274000050266	LPR 40	40,2	40,2	70	30	146	70	62	110	53	551	9021601	9022601

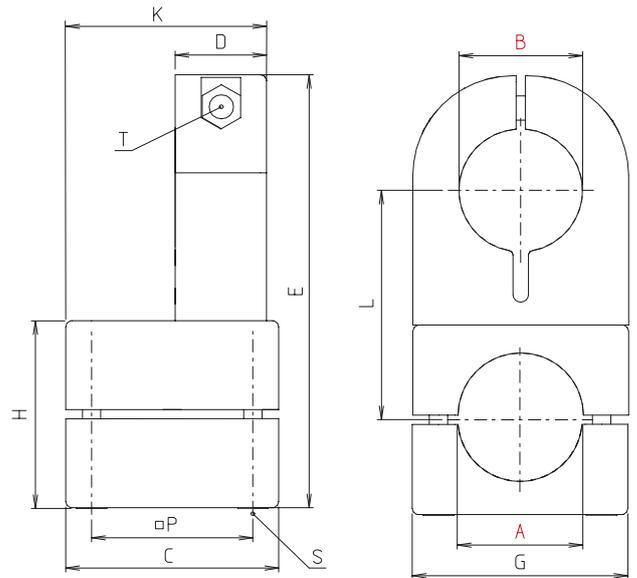

LQR - Série bloc

[mm]

Code No.	Type	A	B	C	D	E	G	H	K	L	P	m [g]	S	T
													Levier de serrage	Code No.
274000060266	LQR 40	40,2	40,2	70	30	142	70	62	66	75	53	694	9021601	9021601

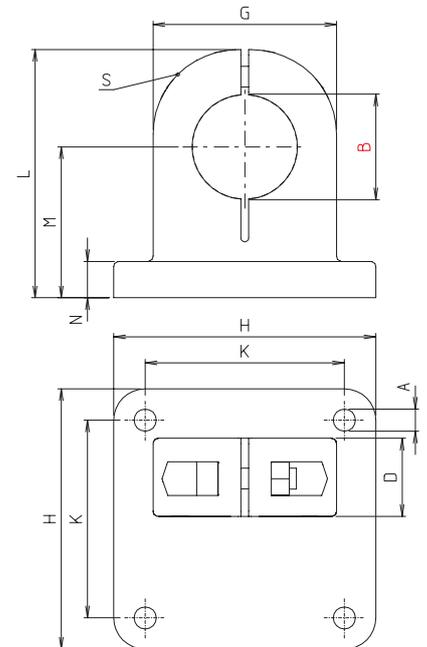

LFR - Série bloc

[mm]

Code No.	Type	A	B	D	G	H	K	L	M	N	m [g]	Levier de serrage S	
												Code No.	
27400002026	LFR 40	8,5	40,2	30	70	100	76	90	58	14	55	9022601	

Solid Clamps – Raccords à collier

Principe de commande:

- Vis galvanisées en équipement standard
- Levier de serrage à commander séparément. Livré non monté. Voir dernière colonne du tableau et page 222

Sur demande:

- Vis en acier inoxydable
- En couleur
- Polissage à billes

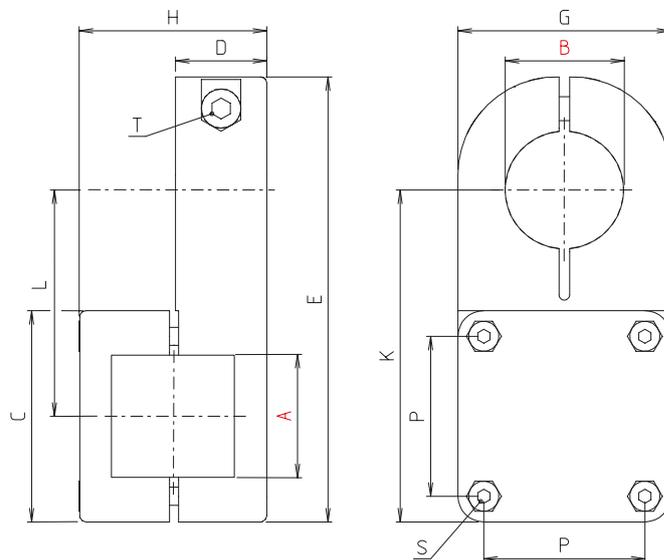

LWV - Série bloc

[mm]

Code No.	Type	A	B	C	D	E	G	H	K	L	P	T	m [g]	Levier de serrage S Code No.
274000070266	LWV 40	40,4	40,2	70	30	146	70	62	110	75	53	M8x30	636	9021601

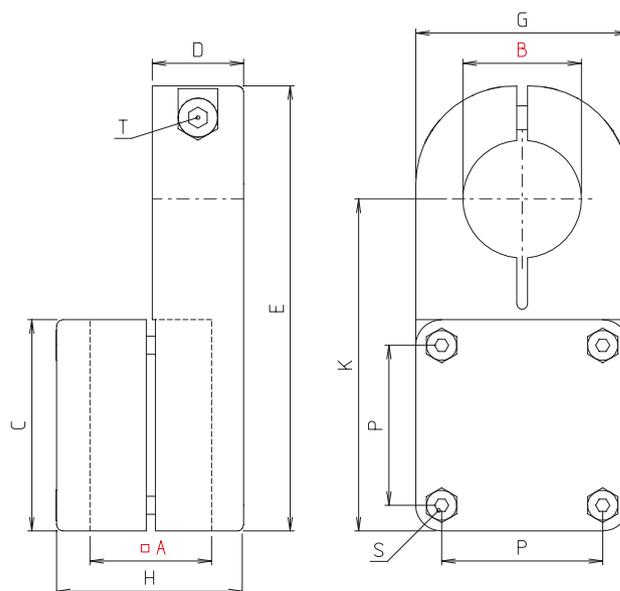

LPV - Série bloc

[mm]

Code No.	Type	A	B	C	D	E	G	H	K	P	T	m [g]	Levier de serrage S Code No.
274000080266	LPV 40	40,4	40,2	70	30	146	70	62	110	53	M8x30	632	9021601

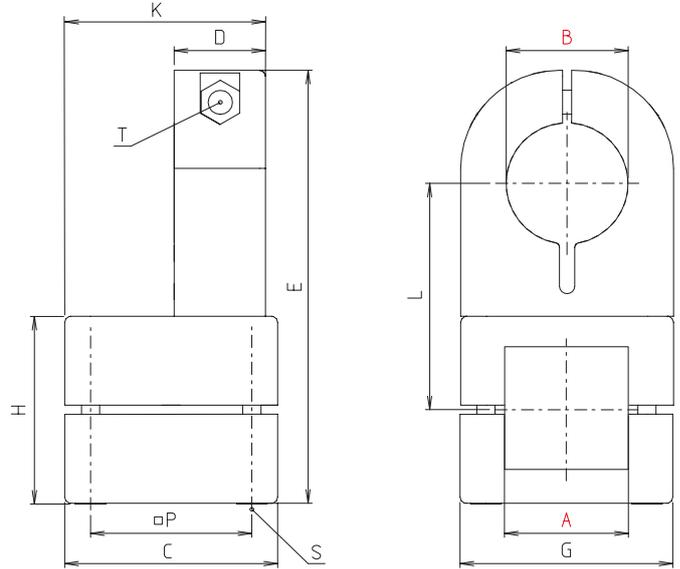

LQV - Série bloc

[mm]

Code No.	Type	A	B	C	D	E	G	H	K	L	P	T	m [g]	Levier de serrage S Code No.
274000090266	LQV 40	40,4	40,2	70	30	142	70	62	66	75	53	M8x30	668	9021601



Versions:

■ Raccords orientables

Livrable
sur stock

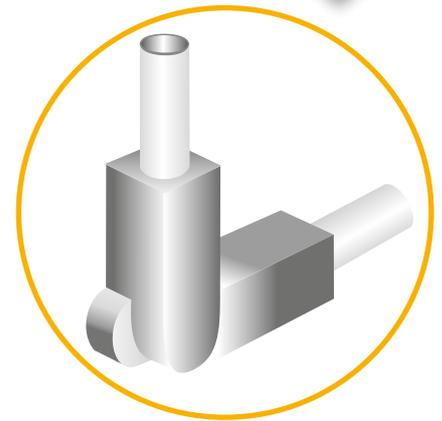

Éléments monoblocs

✓ Pour un montage plus rapide et économique



Série industrie

- Fonte d'aluminium
- Grande diversité
- Éléments monoblocs



Éléments en plusieurs parties

✓ Également conçus pour les montages et extensions a posteriori



Série bloc

- Fonte d'aluminium
- Contrainte de couple plus élevée
- Contours extérieurs plans
- Éléments en plusieurs parties

Charges admissibles

ATTENTION !

Les valeurs données dans les tableaux ne constituent pas un engagement sur les valeurs ni une garantie de résultat à propos de nos produits.

Il ne s'agit que de valeurs indicatives non contractuelles, qui peuvent dans certains cas ne pas être atteintes, dépendant notamment de divers facteurs liés aux applications, comme la température ou la nature de la surface des tubes.

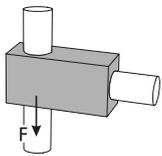

Adhérence F [KN]

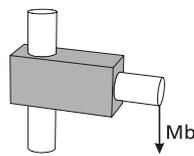

Moment de flexion Mb [Nm]

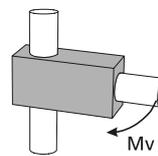

Couple de torsion Mv [Nm]

Couple de serrage des vis:

M6: 10 Nm

M8: 25 Nm

M10: 50 Nm

Talle Type	10			18			30			40			50			60		
	F	Mb	Mv	F	Mb	Mv	F	Mb	Mv	F	Mb	Mv	F	Mb	Mv	F	Mb	Mv
Série industrie																		
GW				2,2	25	7	5,8	85	15	6	233	38	11,9	244	143			
GP				1,1	25	7	4,8	85	15	6	233	38	12	244	143			
GQ				2,2	25	7	4,8	85	15	6	233	38	12	244	143			
GF				2,2	25	7	4,8	85	15	6	233	100	12	244	143			
GWZ				2,2	27	16	5,8	85	148	6	223	376	11,9	317	695			
GPZ				1,1	27	16	4,8	85	148	6	300	300	12	260	400			
GQZ				2,2	27	16	4,8	85	148	6	223	376	12	317	695			
GFZ				2,2	27	16	5,8	69	82	7,4	240	470	7,8	363	695			

Talle Type	10			18			30			40			50			60		
	F	Mb	Mv	F	Mb	Mv	F	Mb	Mv	F	Mb	Mv	F	Mb	Mv	F	Mb	Mv
Série bloc																		
GKR										5,7	253	43	9,3	563	60			
GKV										2,9	253	43	5,9	563	60			
GFKR										5,7	253	43	9,3	563	60			
GFKV										2,9	410	43	5,9	563	60			
GKRZ										5,7	343	619	9,3	444	548			
GKVZ										2,9	343	619	5,9	444	548			
GFKRZ										5,7	343	619	9,3	444	548			
GFKVZ										1,6	343	619	5,9	444	548			
GWR										5,7	306	75						
GPR										5,7	306	75						
GQR										5,7	375	75						
GFR										5,7	308	75						
GWV										2,9	306	75						
GPV										2,9	306	75						
GQV										2,9	306	75						
GFV										2,9	306	75						

Solid Clamps – Raccords orientables

Raccords tubulaires
perpendiculaires

Série industrie



Série bloc





Solid Clamps – Raccords orientables

Principe de commande:

- Vis galvanisées en équipement standard
- Levier de serrage à commander séparément. Livré non monté. Voir dernière colonne du tableau et page 222

Sur demande:

- Vis en acier inoxydable
- En couleur
- Polissage à billes

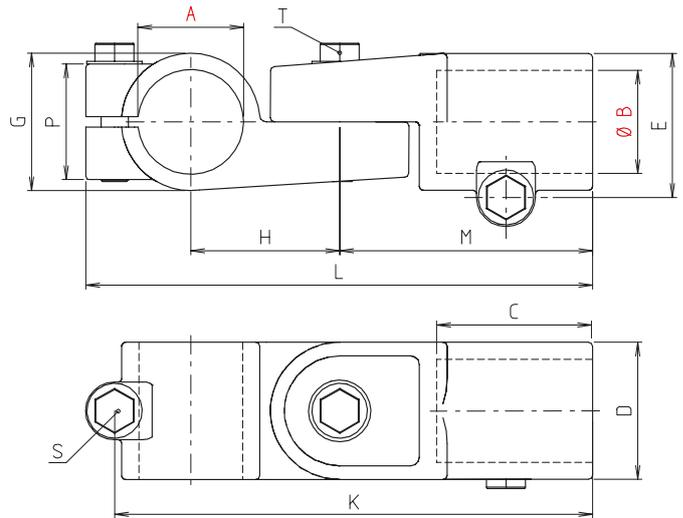

non denté – 180° progressivement réglable



Type GW 12–18



Type GW 20–60

GW - Série industrie

[mm]

Code No.	Type	A	B	C	D	E	G	H	K	L	M	P	m [g]	S	T	
														Levier de serrage Code No.		
181200010200	GW 12	12,1	12,1	25	26	29,4	26	27	84	95,5	44	21	135	90210	90210	
181400010200	GW 14	14,1	14,1													129
181600010200	GW 16	16,1	16,1													123
181800010200	GW 18	18,1	18,1													115
182000010200	GW 20	20	20	45	40	40	40	43	136	146	73	33	387	9022401	9022401	
182500010200	GW 25	25,1	25,1													346
183000010200	GW 30	30,1	30,1													300
183200010200	GW 32	32,2	32,2	60	56	56	56	60	188	200	100	48	961	9024301	-	
183500010200	GW 35	35,2	35,2													900
184000010200	GW 40	40,2	40,2													810
184200010200	GW 42	42,2	42,2													1335
184500010200	GW 45	45,2	45,2	70	66	66	66	70	218	230	115	58	1253	9024401	-	
184800010200	GW 48	48,2	48,2													1177
185000010200	GW 50	50,2	50,2													1121
186000010200	GW 60	60,3	60,3													2050
				80	80	80	85	85	260	273	135	68		9024401	9024401	

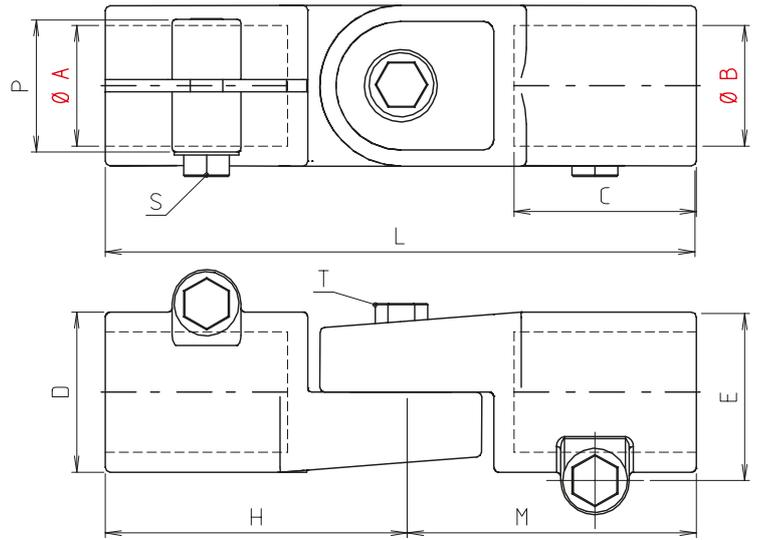

non denté – 180° progressivement réglable



Type GP 12-18



Type GP 20-60

GP - Série industrie

[mm]

Code No.	Type	A	B	C	D	E	H	L	M	P	m [g]	Levier de serrage S Code No.
181200000200	GP 12	12,1	12,1	25	26	29,4	44	88	44	21	135	90210
181400000200	GP 14	14,1	14,1								129	
181600000200	GP 16	16,1	16,1								123	
181800000200	GP 18	18,1	18,1								115	
182000000200	GP 20	20	20	45	40	40	73	146	73	33	419	9022401
182500000200	GP 25	25,1	25,1								374	
183000000200	GP 30	30,1	30,1								328	
183200000200	GP 32	32,15	32,15	60	56	56	100	200	100	48	1028	9024301
183500000200	GP 35	35,15	35,15								972	
184000000200	GP 40	40,15	40,15								871	
184200000200	GP 42	42,2	42,2								1440	
184500000200	GP 45	45,2	45,2	70	66	66	115	230	115	58	1355	9024401
184800000200	GP 48	48,2	48,2								1279	
185000000200	GP 50	50,2	50,2								1213	
186000000200	GP 60	60,25	60,25								220	

Solid Clamps – Raccords orientables

Principe de commande:

- Vis galvanisées en équipement standard
- Levier de serrage à commander séparément. Livré non monté. Voir dernière colonne du tableau et page 222

Sur demande:

- Vis en acier inoxydable
- En couleur
- Polissage à billes

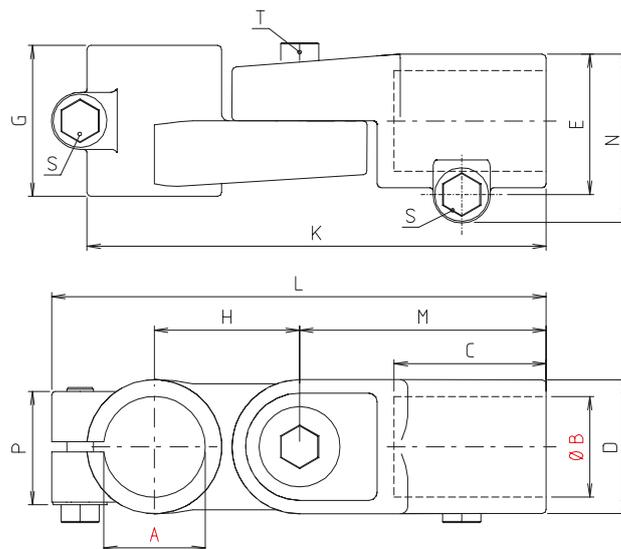

non denté – 180° progressivement réglable



GQ - Série industrie

Code No.	Type	A	B	C	D	E	G	H	K	L	M	N	P	m [g]	[mm]		
															S	T	
182000030200	GQ 20	20	20	45	40	40	45	43	136	146	73	50	33	409	9022401	9022401	
182500030200	GQ 25	25,1	25,1													9022401	
183000030200	GQ 30	30,1	30,1													-	
183200030200	GQ 32	32,2	32,2	60	56	56	60	60	188	200	100	68	48	1005	9024301	9024301	
183500030200	GQ 35	35,2	35,2														922
184000030200	GQ 40	40,2	40,2														822
184200030200	GQ 42	42,2	42,2	70	66	66	70	70	218	230	115	78	58	1405	9024401	9024401	
184500030200	GQ 45	45,2	45,2														1302
184800030200	GQ 48	48,2	48,2														1221
185000030200	GQ 50	50,2	50,2														1164

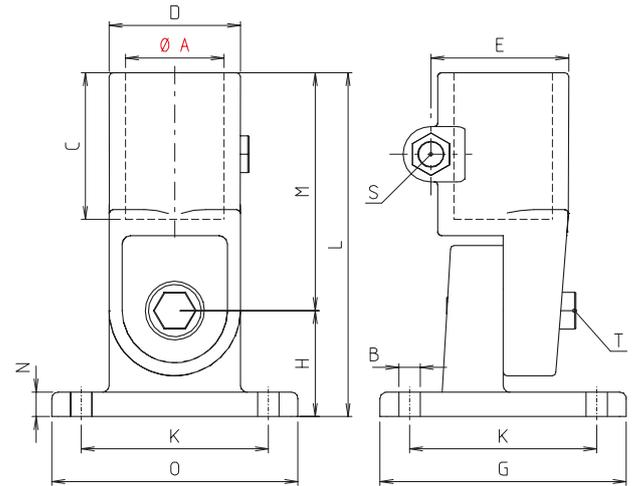

non denté – 180° progressivement réglable



Type GF 12–18



Type GF 20–50

GF - Série industrie

[mm]

Code No.	Type	A	B	C	D	E	G	H	K	L	M	N	O	m [g]	Levier de serrage S Code No.
18120002020	GF 12	12,1	5,3	25	26	29,4	50	20	38-40	64	44	5	35	106	90210
18140002020	GF 14	14,1												103	
18160002020	GF 16	16,1												100	
18180002020	GF 18	18,1												96	
18200002020	GF 20	20	7	45	40	40	75	33	57	106	73	7	75	371	9022401
18250002020	GF 25	25,1												374	
18300002020	GF 30	30,1												325	
18320002020	GF 32	32,2	9	60	56	56	100	44	76	144	100	10	100	963	9024301
18350002020	GF 35	35,2												880	
18400002020	GF 40	40,2												827	
18420002020	GF 42	42,2												1378	
18450002020	GF 45	45,2	9	70	66	66	125	52	98	167	115	12	125	1287	9022401
18480002020	GF 48	48,2												1233	
18500002020	GF 50	50,2												1213	

Solid Clamps – Raccords orientables

Principe de commande:

- Vis galvanisées en équipement standard
- Levier de serrage à commander séparément. Livré non monté. Voir dernière colonne du tableau et page 222

Sur demande:

- Vis en acier inoxydable
- En couleur
- Polissage à billes

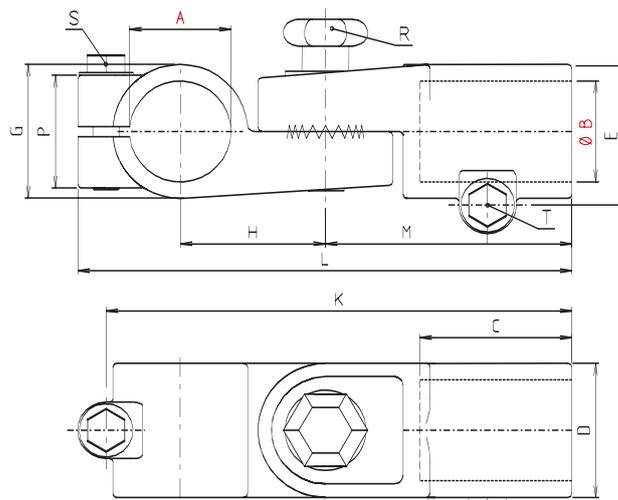

denté – angle de rotation 180°, encliquetage tous les 15°



Type GWZ 12–18



Type GWZ 20–60

GWZ - Série industrie

Code No.	Type	A	B	C	D	E	G	H	K	L	M	P	R	T	m [g]	Levier de serrage S Code No.
181200040200	GWZ 12	12,1	12,1	25	26	29,4	26	27	84	95,5	44	21	M6x26	M6x16	135	90210
181400040200	GWZ 14	14,1	14,1												129	
181600040200	GWZ 16	16,1	16,1												123	
181800040200	GWZ 18	18,1	18,1												115	
182000040200	GWZ 20	20	20	45	40	40	40	43	136	146	73	33	M8x40	M8x35	428	9022401
182500040200	GWZ 25	25,1	25,1												391	
183000040200	GWZ 30	30,1	30,1												344	
183200040200	GWZ 32	32,2	32,2	60	56	56	56	60	188	200	100	48	M10x50	M10x50	999	9024301
183500040200	GWZ 35	35,2	35,2												943	
184000040200	GWZ 40	40,2	40,2												861	
184200040200	GWZ 42	42,2	42,2												1361	
184500040200	GWZ 45	45,2	45,2	70	66	66	66	70	218	230	115	58	M10x50	M10x60	1287	9024401
184800040200	GWZ 48	48,2	48,2												1211	
185000040200	GWZ 50	50,2	50,2												1166	
186000040200	GWZ 60	60,3	60,3												2050	
				80	80	80	85	85	260	273	135	68	M12x50	M10x60		9024401

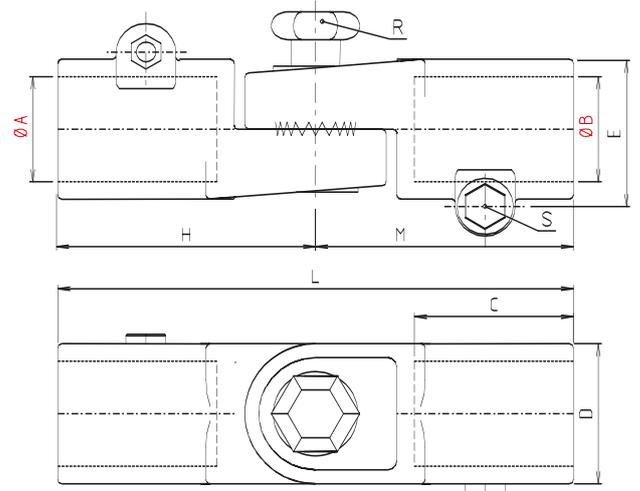

denté – angle de rotation 180°, encliquetage tous les 15°



Type GPZ 12–18



Type GPZ 20–60

GPZ - Série industrie

[mm]

Code No.	Type	A	B	C	D	E	H	L	M	R	m [g]	Levier de serrage S Code No.
181200050200	GPZ 12	12,1	12,1	25	26	29,4	44	95,5	44	M6x26	135	90210
181400050200	GPZ 14	14,1	14,1								129	
181600050200	GPZ 16	16,1	16,1								123	
181800050200	GPZ 18	18,1	18,1								115	
182000050200	GPZ 20	20	20	45	40	40	73	146	73	M8x40	460	9022401
182500050200	GPZ 25	25,1	25,1								414	
183000050200	GPZ 30	30,1	30,1								370	
183200050200	GPZ 32	32,2	32,2	60	56	56	100	200	100	M10x50	1069	9024301
183500050200	GPZ 35	35,2	35,2								1012	
184000050200	GPZ 40	40,2	40,2	70	66	66	115	230	115	M10x60	916	9024401
184200050200	GPZ 42	42,2	42,2								1482	
184500050200	GPZ 45	45,2	45,2								1393	
184800050200	GPZ 48	48,2	48,2								1316	
185000050200	GPZ 50	50,2	50,2	80	80	80	135	270	135	M12x50	1261	9024401
186000050200	GPZ 60	60,3	60,3								2200	

Solid Clamps – Raccords orientables

Principe de commande:

- Vis galvanisées en équipement standard
- Levier de serrage à commander séparément. Livré non monté. Voir dernière colonne du tableau et page 222

Sur demande:

- Vis en acier inoxydable
- En couleur
- Polissage à billes

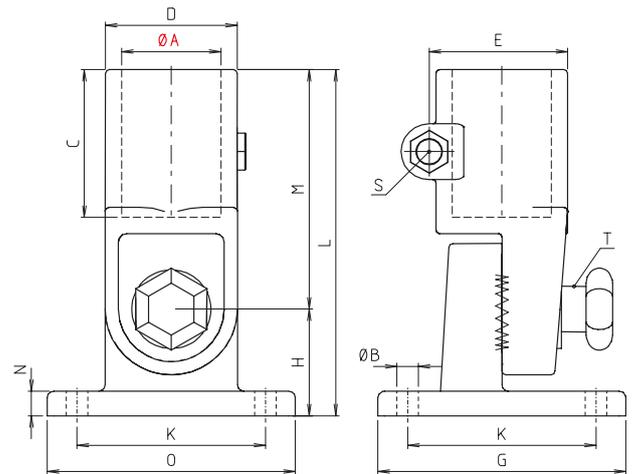

denté – angle de rotation 180°, encliquetage tous les 15°



TYPE GFZ 12–18



TYPE GFZ 20–50

GFZ - Série industrie

[mm]

Code No.	Type	A	B	C	D	E	G	H	K	L	M	N	O	T	m [g]	Levier de serrage S Code No.
18120007020	GFZ 12	12,1	5,3	25	26	29,4	50	27	40	64	44	5	35	M6x26	106	90210
18140007020	GFZ 14	14,1													103	
18160007020	GFZ 16	16,1													100	
18180007020	GFZ 18	18,1													96	
18200007020	GFZ 20	20	7	45	40	40	75	32,5	57	105,5	73	7	75	M8x50	409	9022401
18250007020	GFZ 25	25,1													398	
18300007020	GFZ 30	30,1													368	
18320007020	GFZ 32	32,2													949	
18350007020	GFZ 35	35,2	9	60	56	56	100	44	76	144	100	10	100	M10x52	923	9024301
18400007020	GFZ 40	40,2													866	
18420007020	GFZ 42	42,2													1365	
18450007020	GFZ 45	45,2													1318	
18480007020	GFZ 48	48,2	9	70	66	66	125	52	98	167	115	12	125	M10x60	1279	9024401
18500007020	GFZ 50	50,2													1287	

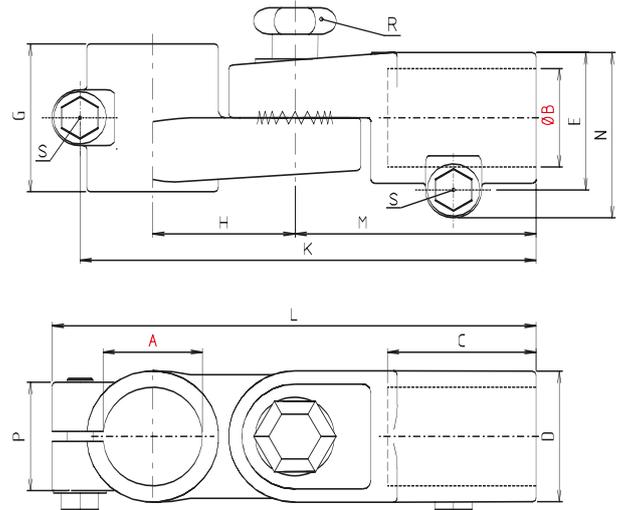

denté – angle de rotation 180°, encliquetage tous les 15°



GQZ - Série industrie

[mm]

Code No.	Type	A	B	C	D	E	G	H	K	L	M	N	P	R	m [g]	Levier de serrage S Code No.
182000060200	GQZ 20	20	20	45	40	40	45	43	136	146	73	50	33	M8x40	450	9022401
182500060200	GQZ 25	25,1	25,1												412	
183000060200	GQZ 30	30,1	30,1												358	
183200060200	GQZ 32	32,2	32,2	60	56	56	60	60	188	200	100	68	48	M10x52	1045	9024301
183500060200	GQZ 35	35,2	35,2												990	
184000060200	GQZ 40	40,2	40,2												870	
184200060200	GQZ 42	42,2	42,2	70	66	66	70	70	218	230	115	78	58	M10x60	1443	9024401
184500060200	GQZ 45	45,2	45,2												1362	
184800060200	GQZ 48	48,2	48,2												1259	
185000060200	GQZ 50	50,2	50,2												1218	

Solid Clamps – Raccords orientables

Principe de commande:

- Vis galvanisées en équipement standard
- Levier de serrage à commander séparément. Livré non monté. Voir dernière colonne du tableau et page 222

Sur demande:

- Vis en acier inoxydable
- En couleur
- Polissage à billes

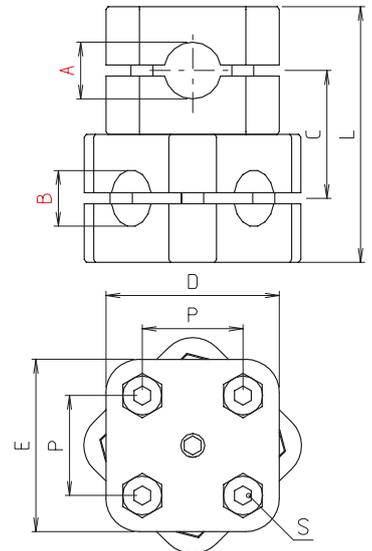

non denté – 360° en continu

GKPR - Série bloc

[mm]

Code No.	Type	A	B	C	D	E	L	P	S	m [g]
290800080266	GKPR 8	8	8	23	31	31	46	18	M4x18	96
291000080266	GKPR 10	10	10							92

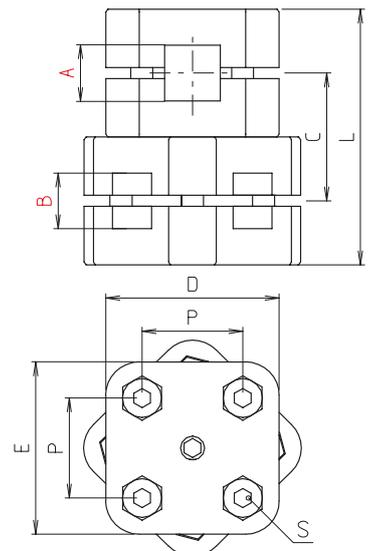

non denté – 360° en continu

GKPV - Série bloc

[mm]

Code No.	Type	A	B	C	D	E	L	P	S	m [g]
291000090266	GKPV 10	10	10	23	31	31	46	18	M4x18	88

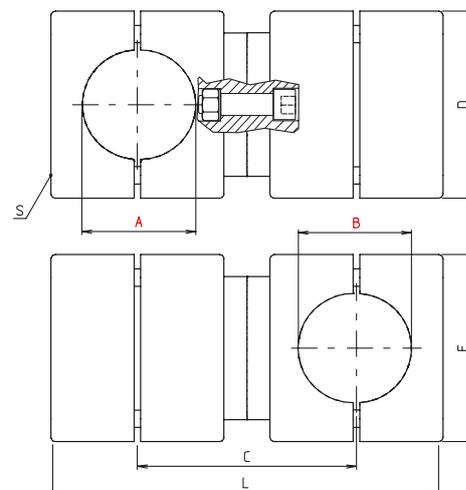

non denté – 360° en continu

GKR - Série bloc

[mm]

Code No.	Type	A	B	C	D	E	L	m [g]	Levier de serrage S Code No.
284000080266	GKR 40	40,2	40,2	75	70	70	137	899	9021601
284200080266	GKR 42	42,3	42,3	100	88	88	179	1997	9022901
284500080266	GKR 45	45,3	45,3					1941	
284800080266	GKR 48	48,3	48,3					1946	
285000080266	GKR 50	50,3	50,3					1903	

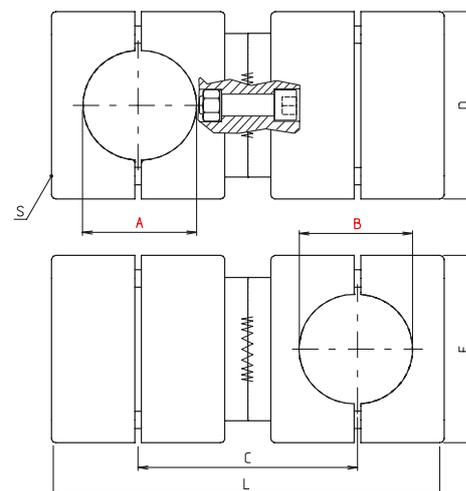

denté – angle de rotation 360°, encliquetage tous les 15°

GKRZ - Série bloc

[mm]

Code No.	Type	A	B	C	D	E	L	m [g]	Levier de serrage S Code No.
284000090266	GKRZ 40	40,2	40,2	75	70	70	137	910	9021601
284200090266	GKRZ 42	42,3	42,3	100	88	88	179	2003	9022901
284500090266	GKRZ 45	45,3	45,3					1956	
284800090266	GKRZ 48	48,3	48,3					1933	
285000090266	GKRZ 50	50,3	50,3					1914	

Solid Clamps – Raccords orientables

Principe de commande:

- Vis galvanisées en équipement standard
- Levier de serrage à commander séparément. Livré non monté. Voir dernière colonne du tableau et page 222

Sur demande:

- Vis en acier inoxydable
- En couleur
- Polissage à billes

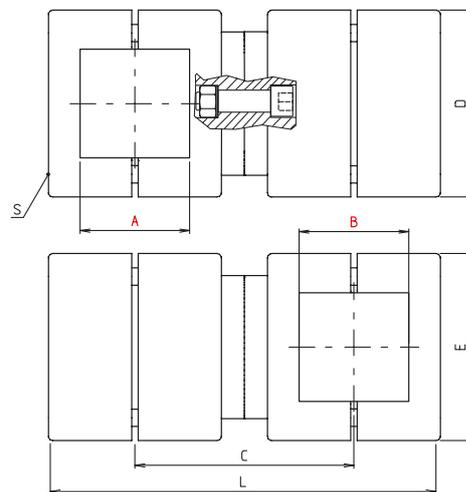

non denté – 360° en continu

GKV - Série bloc

[mm]

Code No.	Type	A	B	C	D	E	L	m [g]	Levier de serrage S Code No.
284000100266	GKV 40	40,4	40,4	75	70	70	137	827	9021601
285000100266	GKV 50	50,5	50,5	100	88	88	179	1816	9022901

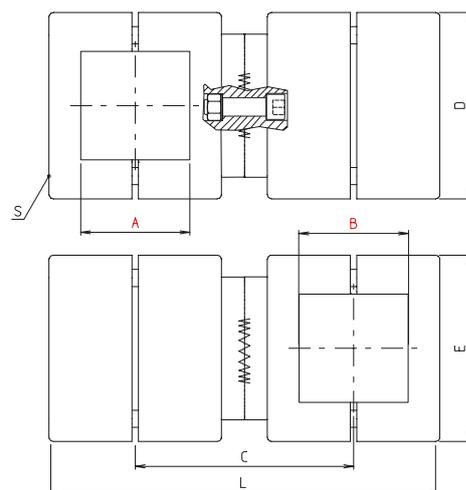

denté – angle de rotation 360°, encliquetage tous les 15°

GKVZ - Série bloc

[mm]

Code No.	Type	A	B	C	D	E	L	m [g]	Levier de serrage S Code No.
284000110266	GKVZ 40	40,4	40,4	75	70	70	137	834	9021601
285000110266	GKVZ 50	50,5	50,5	100	88	88	179	1826	9022901

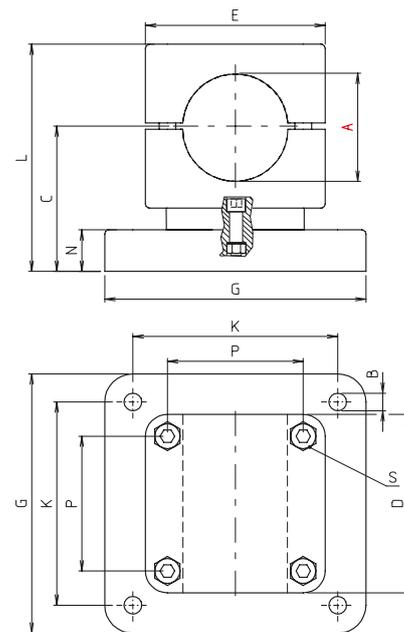

non denté – 360° en continu

GFKR - Série bloc

Code No.	Type	A	B	C	D	E	G	K	L	N	P	m [g]	Levier de serrage S Code No.
28400012026	GFKR 40	40,2	8,5	58	70	70	125	98	88,5	20	53	1064	9021601
28420012026	GFKR 42	42,3	8,5	70	88	88	125	98	109,5	20	65	1606	9022901
28450012026	GFKR 45	45,3										1576	
28480012026	GFKR 48	48,3										1570	
28500012026	GFKR 50	50,3										1566	

[mm]

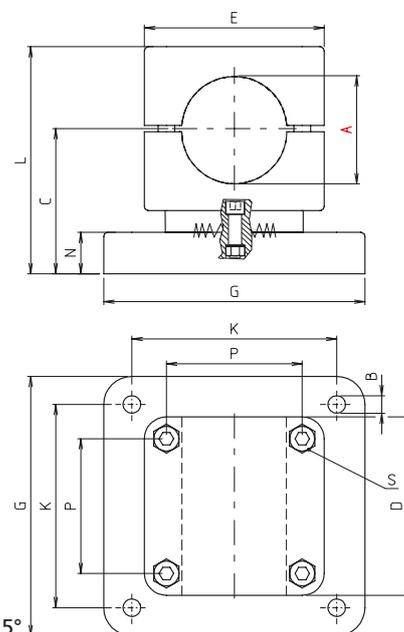

denté – angle de rotation 360°, encliquetage tous les 15°

GFKRZ - Série bloc

Code No.	Type	A	B	C	D	E	G	K	L	N	P	m [g]	Levier de serrage S Code No.
28400013026	GFKRZ 40	40,2	8,5	58	70	70	125	98	88,5	20	53	1066	9021601
28420013026	GFKRZ 42	42,3	8,5	70	88	88	125	98	109,5	20	65	1615	9022901
28450013026	GFKRZ 45	45,3										1590	
28480013026	GFKRZ 48	48,3										1576	
28500013026	GFKRZ 50	50,3										1565	

[mm]

Solid Clamps – Raccords orientables

Principe de commande:

- Vis galvanisées en équipement standard
- Levier de serrage à commander séparément. Livré non monté. Voir dernière colonne du tableau et page 222

Sur demande:

- Vis en acier inoxydable
- En couleur
- Polissage à billes

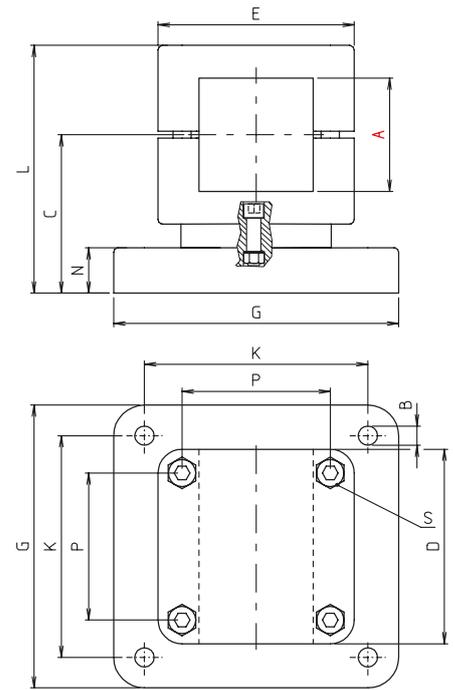

non denté – 360° en continu

GFKV - Série bloc

Code No.	Type	A	B	C	D	E	G	K	L	N	P	m [g]	Levier de serrage S Code No.
28400014026	GFKV 40	40,4	8,5	58	70	70	125	98	88,5	20	53	1025	9021601
28500014026	GFKV 50	50,5	8,5	70	88	88	125	98	110	20	65	1515	9022901

[mm]

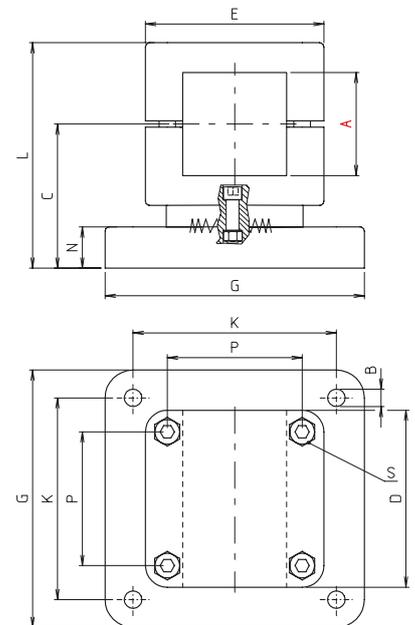

denté – angle de rotation 360°, encliquetage tous les 15°

GFKVZ - Série bloc

Code No.	Type	A	B	C	D	E	G	K	L	N	P	m [g]	Levier de serrage S Code No.
28400015026	GFKVZ 40	40,4	8,5	58	70	70	125	98	88,5	20	53	1031	9021601
28500015026	GFKVZ 50	50,5		70	88	88			109,5		65	1522	9022901

[mm]

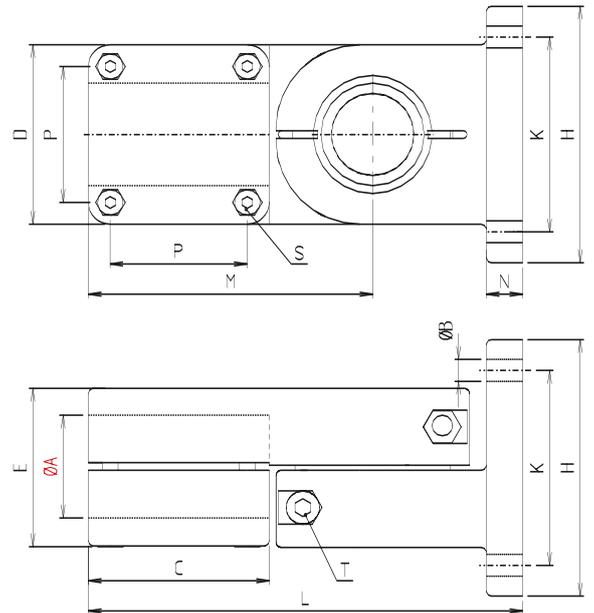

Plage de rotation 180°, réglable en continu

GFR - Série bloc

[mm]

Code No.	Type	A	B	C	D	E	H	K	L	M	N	P	m [g]	S	T
														Levier de serrage Code No.	
28400018026	GFR 40	40,2	8,5	70	70	62	100	76	168	110	14	53	143	9021601	9022301

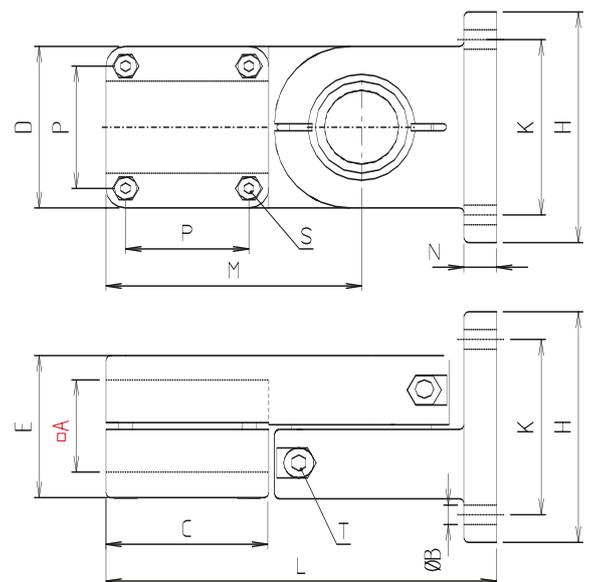

angle de rotation 180°, encliquetage tous les 15°

GFV - Série bloc

[mm]

Code No.	Type	A	B	C	D	E	H	K	L	M	N	P	m [g]	S	T
														Levier de serrage S Code No.	
28400022026	GFV 40	40,4	8,5	70	70	62	100	76	168	110	14	53	1413	9021601	9022301

Solid Clamps – Raccords orientables

Principe de commande:

- Vis galvanisées en équipement standard
- Levier de serrage à commander séparément. Livré non monté. Voir dernière colonne du tableau et page 222

Sur demande:

- Vis en acier inoxydable
- En couleur
- Polissage à billes

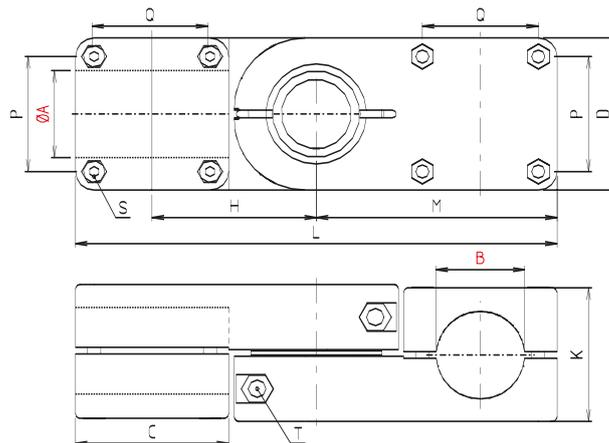

angle de rotation 180° en continu

GWR - Série bloc

Code No.	Type	A	B	C	D	H	K	L	M	P	Q	m [g]	[mm]	
													S	T
284000160266	GWR 40	40,2	40,2	70	70	75	62	220	110	53	53	154	9021601	9300201

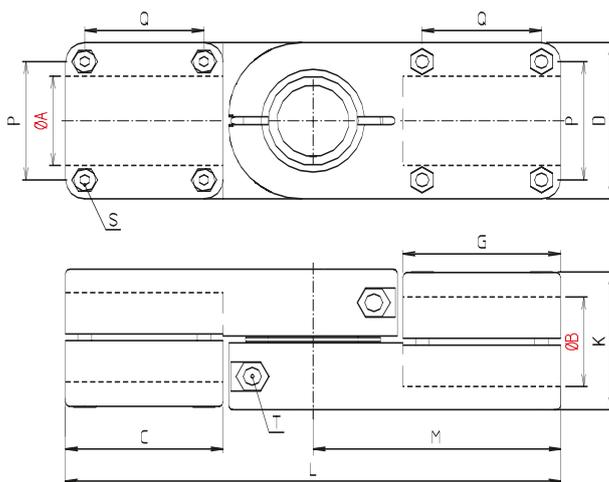

angle de rotation 180° en continu

GPR - Série bloc

Code No.	Type	A	B	C	D	E	G	K	L	M	P	Q	m [g]	[mm]	
														S	T
284000170266	GPR 40	40,2	40,2	70	70	62	70	62	220	110	53	53	1533	9021601	9300201

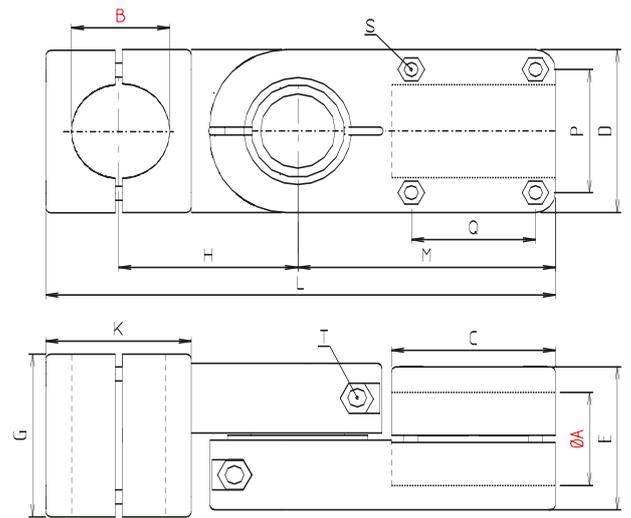

angle de rotation 180° en continu

GQR - Série bloc

Code No.	Type	A	B	C	D	E	G	H	K	L	M	P	Q	m [g]	S	T
															Levier de serrage Code No.	
284000190266	GQR 40	40,2	40,2	70	70	62	70	75	76	216	110	53	53	1583	9021601	9300201

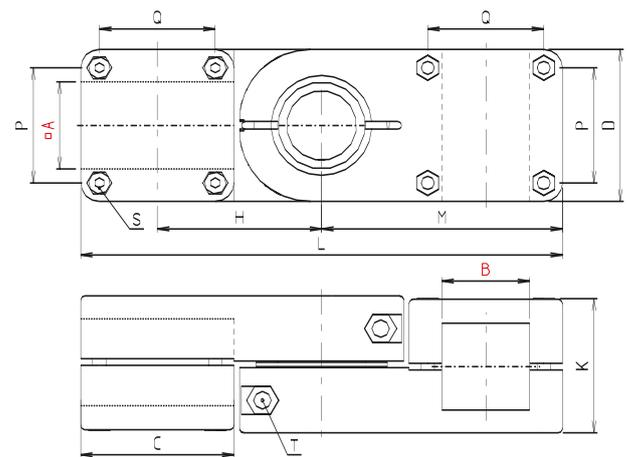

angle de rotation 180° en continu

GWV - Série bloc

Code No.	Type	A	B	C	D	H	K	L	M	P	Q	m [g]	S	T
													Levier de serrage Code No.	
284000200266	GWV 40	40,4	40,4	70	70	75	62	220	110	53	53	1473	9021601	9300201

Solid Clamps – Raccords orientables

Principe de commande:

- Vis galvanisées en équipement standard
- Levier de serrage à commander séparément. Livré non monté. Voir dernière colonne du tableau et page 222

Sur demande:

- Vis en acier inoxydable
- En couleur
- Polissage à billes

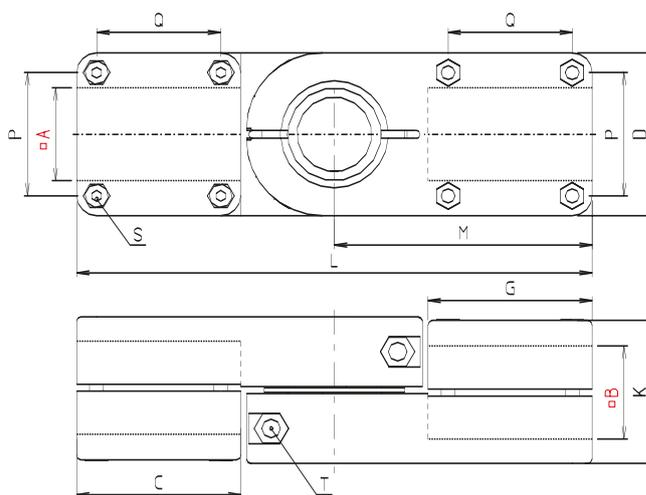

angle de rotation 180° en continu

GPV - Série bloc

[mm]

Code No.	Type	A	B	C	D	G	K	L	M	P	Q	R	m [g]	Levier de serrage S Code No.
284000210266	GPV 40	40,4	40,4	70	70	70	62	220	110	53	53	M6x55	1486	9021601

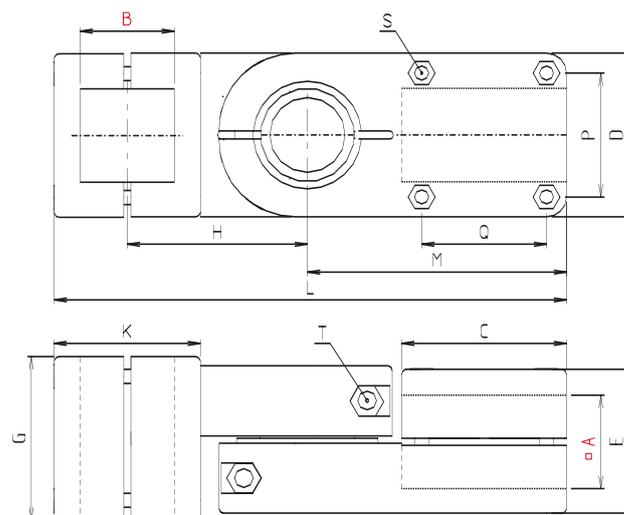

angle de rotation 180° en continu

GQV - Série bloc

[mm]

Code No.	Type	A	B	C	D	G	H	K	L	M	P	Q	m [g]	Levier de serrage S Code No.
284000230266	GQV 40	40,4	40,4	70	70	70	75	62	216	110	53	53	1523	9021601

Coupe

Série industrie sans denture

Axe de rotation réalisé par vis

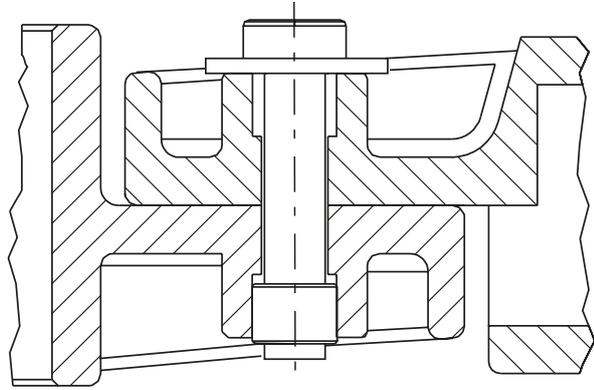

Série industrie avec denture

Axe de rotation réalisé par vis moletée

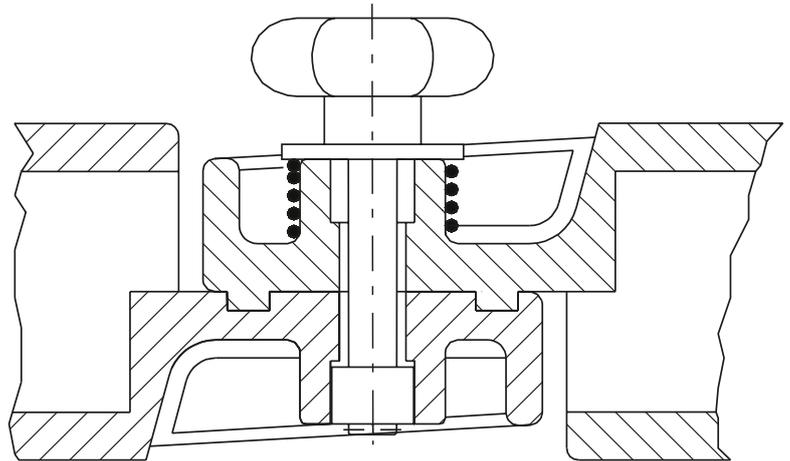

Raccord tubulaire Série bloc

Axe de rotation réalisé par tube et rondelle

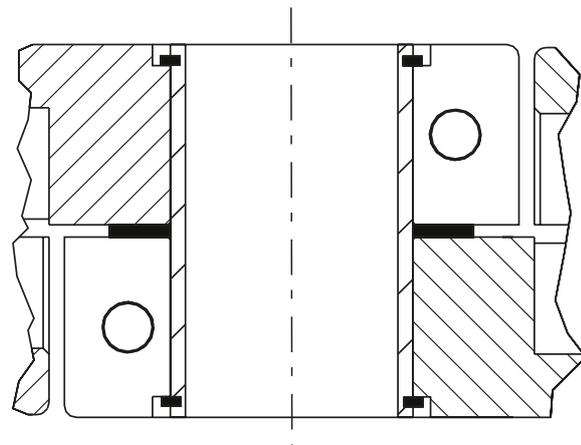

Toutes les combinaisons des diamètres nominaux A et B sont disponibles sur demande.



Versions:

■ Articulation sphérique

Livrable
sur stock



Éléments monoblocs

✓ Pour un montage plus rapide et économique

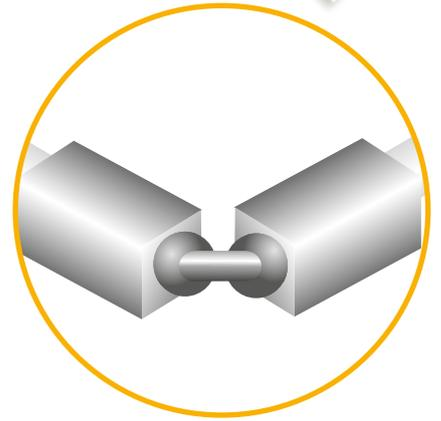

Série industrie

- Fonte d'aluminium
- Grande diversité
- Éléments monoblocs

Caractéristiques:

- ✓ Les applications raccordées peuvent librement pivoter sur 60° et effectuer des rotations de 360°
- ✓ Combinable avec la accord de tube taille 30
- ✓ Les éléments de serrage sont équipés d'une plaque de connexion universelle pour un raccordement flexible
- ✓ Un revêtement adapté de la surface de l'articulation sphérique assure un serrage extrêmement résistant
- ✓ Les articulations sphériques sont conçues pour résister à des charges (statiques) pouvant atteindre 40 Nm



Charges admissibles

ATTENTION !

Les valeurs données dans les tableaux ne constituent pas un engagement sur les valeurs ni une garantie de résultat à propos de nos produits.

Il ne s'agit que de valeurs indicatives non contractuelles, qui peuvent dans certains cas ne pas être atteintes, dépendant notamment de divers facteurs liés aux applications, comme la température ou la nature de la surface des tubes.

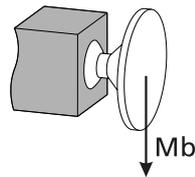

Moment de flexion Mb [Nm]

Taille	10	18	30	Couple de serrage des vis:
Type	Mb	Mb	Mb	
Série industrie				
KGFS	-	-	40	M6: 10 Nm
KGM	-	-	40	M8: 25 Nm
KGGPZ	-	-	40	M10: 50 Nm
KGMM	-	-	40	

Aperçu

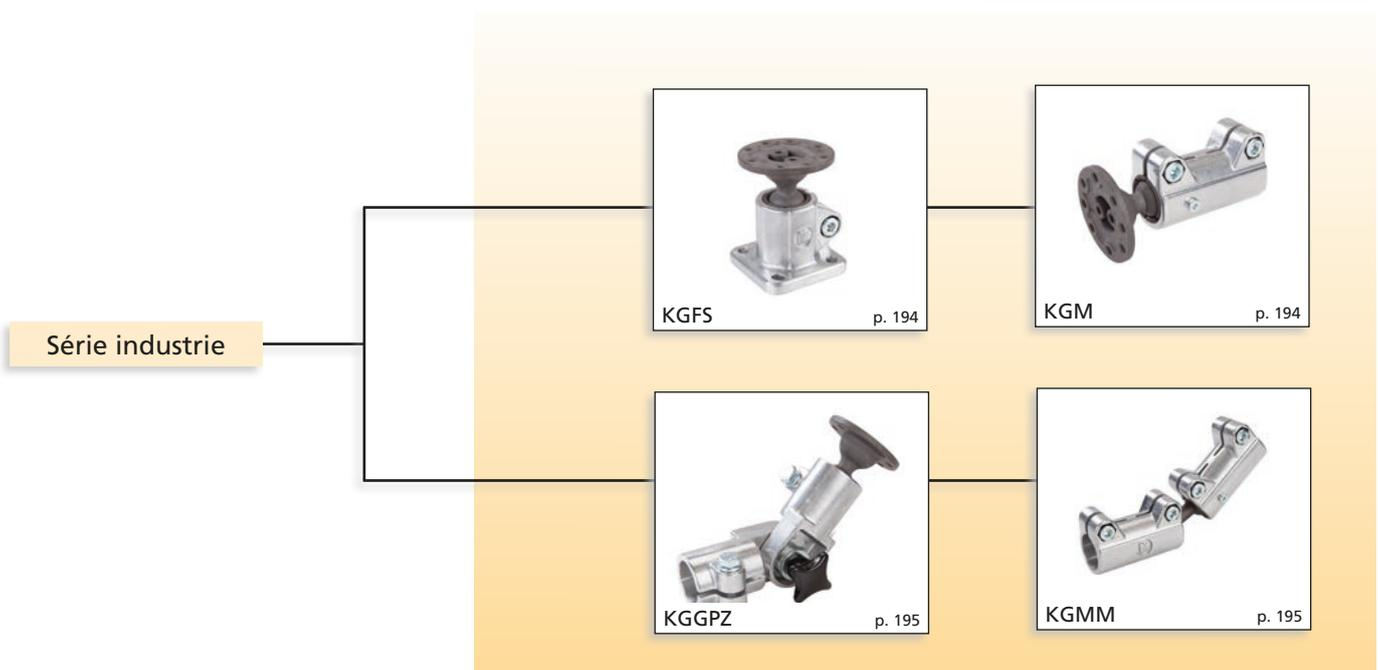

Solid Clamps – Articulations sphériques

Principe de commande:

- Vis galvanisées en équipement standard

Sur demande:

- Vis en acier inoxydable
- En couleur
- Polissage à billes



Type KGFS 30

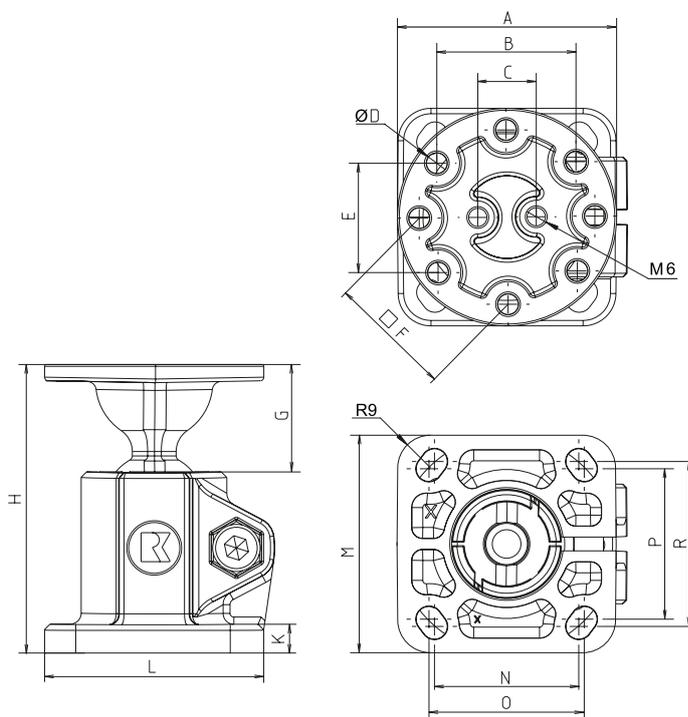

KGFS - Série industrie

[mm]

Code No.	Type	A	B	C	D	E	F	G	H	K	L	M	N	O	P	R	m [g]
133000350260	KGFS 30	60	38,1	16	5,8	30,2	34	30	80	8	60	60	39,5	42,5	41,5	45,5	



Type KGM 30

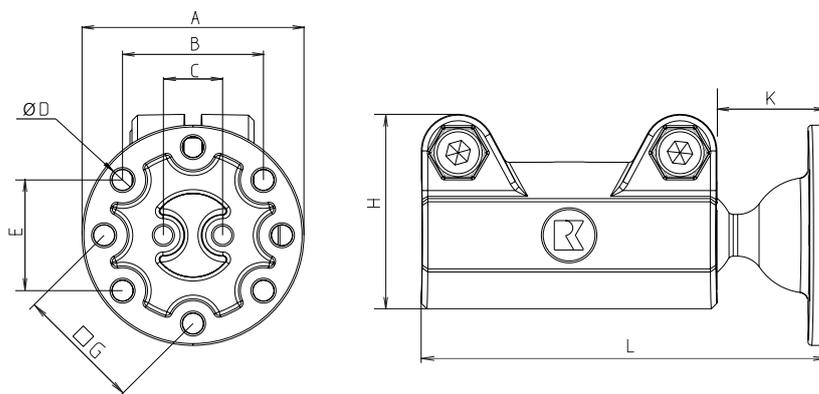

KGM - Série industrie

[mm]

Code No.	Type	A	B	C	D	E	G	H	K	L	m [g]
143000350260	KGM 30	60	38,1	16	5,8	30,2	34	53	30	110	



Type KGGPZ 30

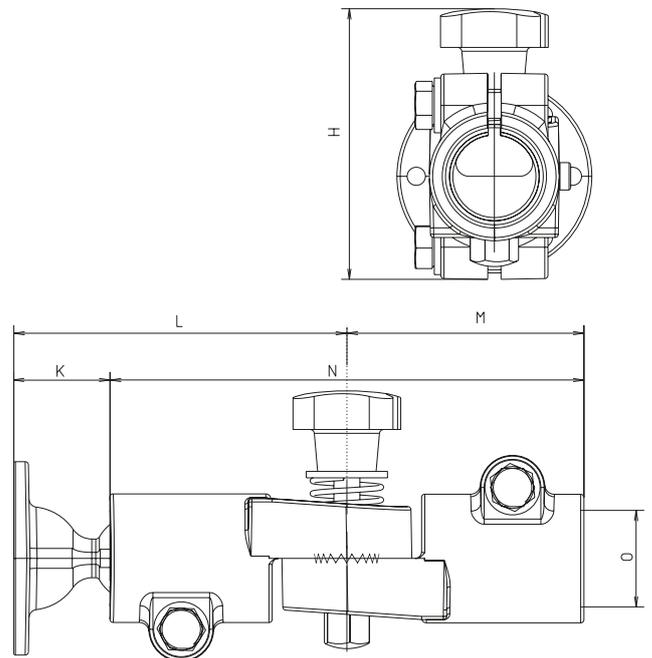
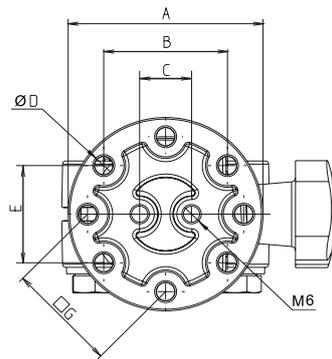

KGGPZ - Série industrie

[mm]

Code No.	Type	A	B	C	D	E	G	H	K	L	M	N	O	m [g]
183000350260	KGGPZ 30	60	38,1	16	5,8	30,2	34	84	30	176	73	146	29,94	

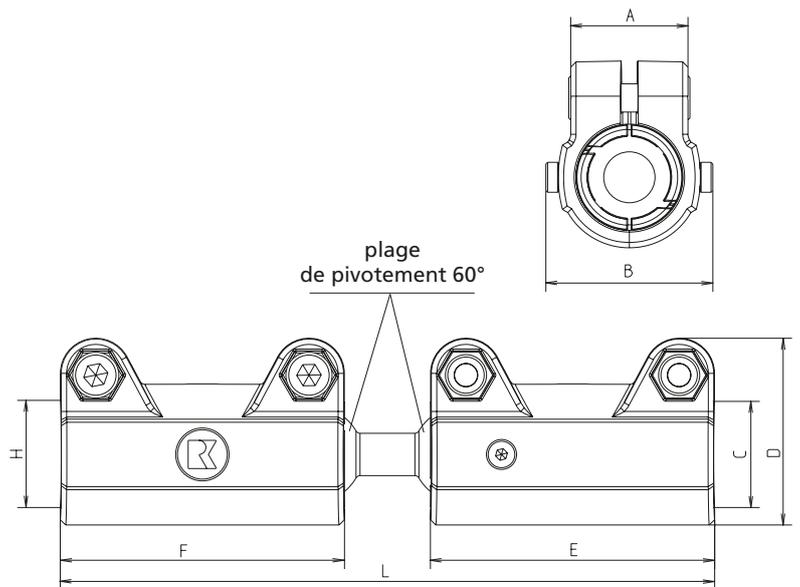

Type KGMM 30

KGMM - Série industrie

[mm]

Code No.	Type	A	B	C	D	E	F	H	L	m [g]
143000360260	KGMM 30	33	47	30,1	53	80	80	30,39	184	



RK ROSE+KRIEGER



Light-, Solid- & Robust Clamps

Accessoiresà partir de la p. 211

Accessoires

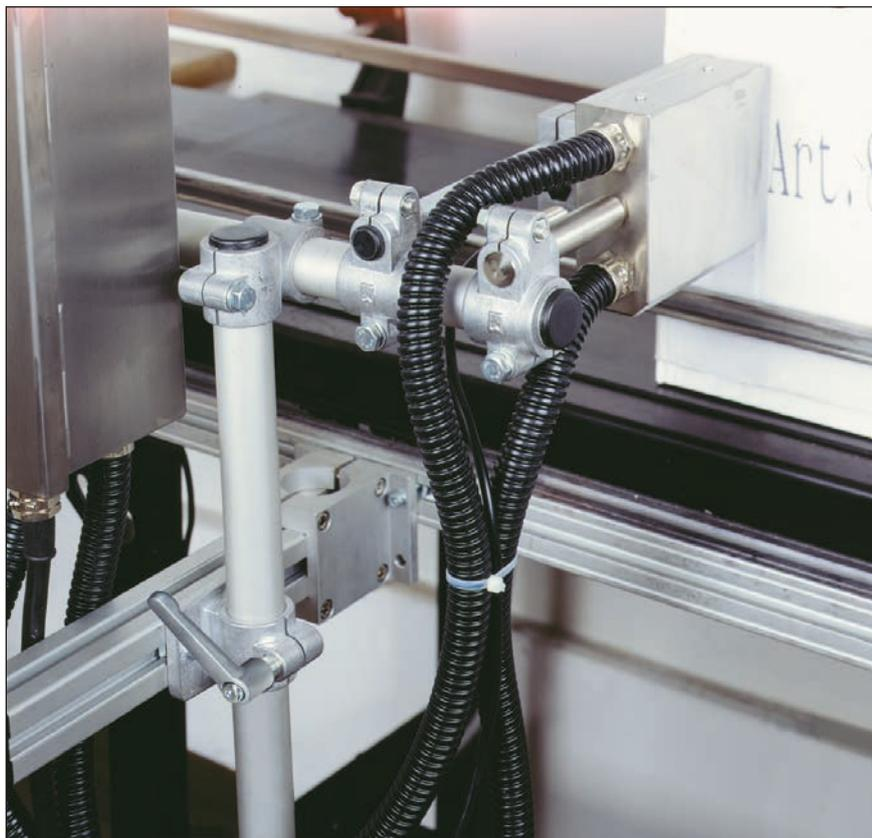
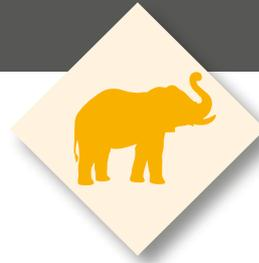

Support de tête d'impression sur une machine à emballer – déplacement universel possible.

Table de matières Accessoires
Accessoires

- Tubes – acier, acier inoxydable, aluminium p. 212



- Barres/Profilés aluminiump. 215



- Bouchons taraudésp. 217



- Bouchonsp. 218



- Fixations de tubep. 219



- Pieds-supportsp. 220



- Roulettesp. 221



- Leviers de serrage / Écrous noyés.....à partir de la p. 222



- Manchon adaptateur R28p. 223

Accessoires

Principe de commande:

- Découpes ou longueurs standard

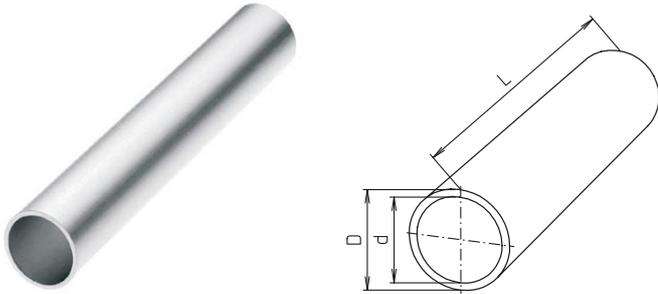

Tubes acier, acier inoxydable / Rond

[mm]

Code No.	Type	D tol. galvanisé	L max. galvanisé	D tol. acier inoxydable	L max. acier inoxydable	d	
801215_ _ _ _ _	12x1,5	12 ± 0,1	6000	12 ± 0,12	3000	9	
801415_ _ _ _ _	14x1,5	14 ± 0,1		14 ± 0,14		11	
801515_ _ _ _ _	15x1,5	15 ± 0,1		15 ± 0,15		12	
801615_ _ _ _ _	16 x1,5	16 ± 0,1		16 ± 0,16		13	
801815_ _ _ _ _	18x1,5	18 ± 0,1		18 ± 0,12		15	
802020_ _ _ _ _	20x2	20 ± 0,1		20 ± 0,12		3000	16
802520_ _ _ _ _	25x2	25 ± 0,1		25 ± 0,25	21		
803020_ _ _ _ _	30x2	30 ± 0,1		30 ± 0,10	26		
803230_ _ _ _ _	32x3	32 ± 0,15		32 ± 0,15	26		
803530* _ _ _ _ _	35x3	35 ± 0,15		–	–		29
804040_ _ _ _ _	40x4	40 + 0,15		40 + 0,12	3000		32
804240* _ _ _ _ _	42x4	42 ± 0,2		–	–	34	
804540* _ _ _ _ _	45x4	45 ± 0,2				37	
804835* _ _ _ _ _	48x3,5	48 ± 0,2				41	
804840* _ _ _ _ _	48x4	48 ± 0,2				40	
805040_ _ _ _ _	50x4	50 + 0,2		50 + 0,15	3000	42	
805540* _ _ _ _ _	55x4	55 ± 0,25	–	–	47		
806050_ _ _ _ _	60x5	60 + 0,25	60 + 0,20	3000	50		
806250* _ _ _ _ _	62x5	62 ± 0,3	–	–	52		
808050* _ _ _ _ _	80x5	80 ± 0,35	5840	–	–	70	

Longueur:
Coupe sur mesure réalisable.
Longueurs standard::**
0500, 1000, 2000, 3000 und 4000 mm

Version:
0 = brut St 37-2
1 = galvanisé St 37-2
2 = Acier inoxydable 1.4301 (comparable AISI 304)

* Indisponible en acier inoxydable
** Longueurs standard pour version galvanisée uniquement

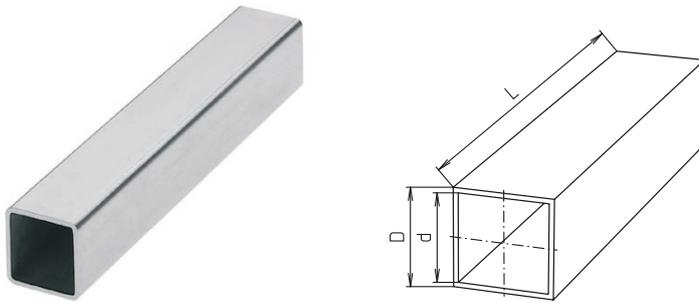

Tubes acier / Carré

[mm]

Code No.	Type	D tol.	L max. acier inoxydable
812010_ _ _ _ _	20x1,5	20 ± 0,2	4000
812515_ _ _ _ _	25x1,5	25 ± 0,25	6000
813020_ _ _ _ _	30x2	30 ± 0,25	4000
814030_ _ _ _ _	40x3	40 ± 0,3	6000
815030_ _ _ _ _	50x3	50 ± 0,3	
816040_ _ _ _ _	60x4	60 ± 0,35	
818050_ _ _ _ _	80x5	80 ± 0,5	

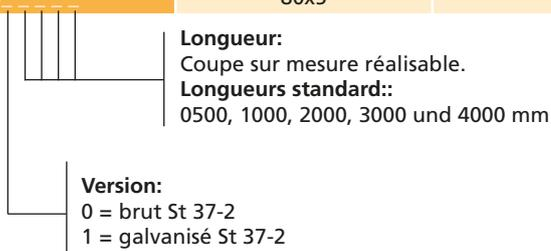

Acier inoxydable / Carré

Tubes du commerce sans tolérance particulière

[mm]

Code No.	Type	D tol.	L max.
8120102_ _ _ _ _	20x1,5	-	6000
8125152_ _ _ _ _	25x1,5	-	
8130202_ _ _ _ _	30x2	-	
8140302_ _ _ _ _	40x3	-	
8150302_ _ _ _ _	50x3	-	
8160402_ _ _ _ _	60x4	-	
8180502_ _ _ _ _	80x5	-	

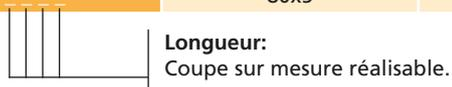

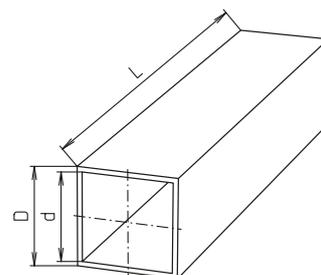
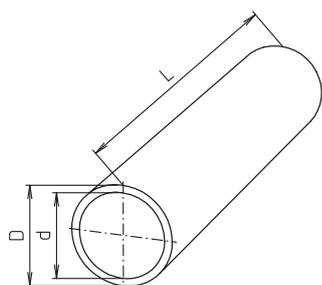

Tubes aluminium

[mm]

Code No.	Type	D tol.	d	L max.
Rond				
822030_ _ _ _ _	20x3	20 ± 0,1	14	6000
823020_ _ _ _ _	30x2	30 ± 0,1	26	
824030_ _ _ _ _	40x3	40 ± 0,15	34	
825030_ _ _ _ _	50x3	50 ± 0,2	44	
826030_ _ _ _ _	60x3	60	54	
Carré				
832015_ _ _ _ _	20x1,5	20 ± 0,2	17	6000
833020_ _ _ _ _	30x2	30 ± 0,2	26	
834040_ _ _ _ _	40x4	40 ± 0,3	32	
835040_ _ _ _ _	50x4	50 ± 0,4	42	
836040_ _ _ _ _	60x4	60 ± 0,4	52	

Longueur:
 Coupe sur mesure réalisable.

Version:
 1 = brut AlMgSi0,5
 2 = anodisé couleur naturelle AlMgSi0,5
 3 = anodisé couleur noir AlMgSi0,5
 (sur demande)

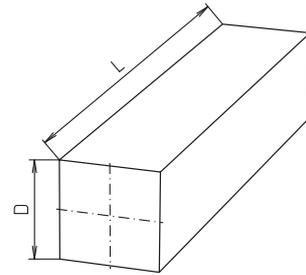
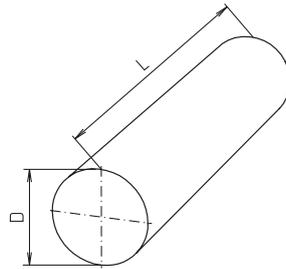

Barres aluminium

[mm]

Code No.	Type	D tol.	L max.
Rond			
820800_ _ _ _ _	8	8	3000
821000_ _ _ _ _	10	10	3000
Carré			
831000	10	10	3000



Longueur:
Coupe sur mesure réalisable.

Version:
1 = brut AlMgSi0,5
2 = anodisé couleur naturelle AlMgSi0,5
3 = anodisé couleur noir AlMgSi0,5
(sur demande)

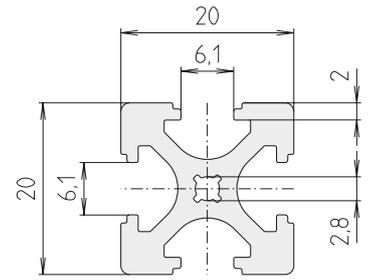

Profilé aluminium F-20 x 20

[mm]

Code No.	Version		Anodisation
E01000BBC	Barre	max. 3000 mm	clair
E01000BBA_ _ _ _	Découpe		clair
E01000BCC	Barre		noir
E01000BCA_ _ _ _	Découpe		noir



Longueur :
 Longueurs standard (anodisé noir ou clair)
 500, 1 000 et 2 000 mm
 Toute découpe possible sur demande

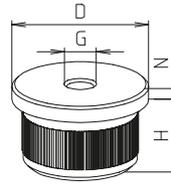

Bouchons taraudés pour tubes ronds

[mm]

Code No.	Type	D	G	H	N
Aluminium					
90321	50x4	50	M10	25	6
90322			M16		
90323	60x5	60	M10	30	6
90324			M16		

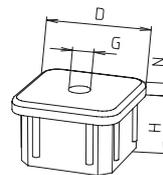

Bouchons taraudés pour tubes carrés

[mm]

Code No.	Type	D	G	H	N
Aluminium					
90421	50x3	50x50	M10	25	6
90422			M16		
90427	60x4	60x60	M10	25	8
90425			M16		
90426			M20		

Principe de commande:

- Unités de vente seulement selon tableau, voir catalogue

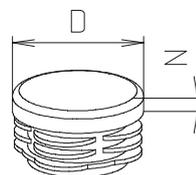

Bouchons ronds

[mm]

Code No.	Type	Tableau des unités de vente	Ø D	N
Polyéthylène, noir				
903011	18x1,5	10, 20, 30... pcs.	18	5
903021	20x2	10, 20, 30... pcs.	20	5
903031	25x2	10, 20, 30... pcs.	25	5
903041	30x2	10, 20, 30... pcs.	30	5
90305	32x3	10, 20, 30... pcs.	32	5
90312	35x3	10, 20, 30... pcs.	35	5
90306	40x3	10, 20, 30... pcs.	40	5
90307	40x4	10, 20, 30... pcs.	40	5
90308	45x4	10, 20, 30... pcs.	45	5
90309	48x4	10, 20, 30... pcs.	48	5
90310	50x3 / 50x4	10, 20, 30... pcs.	50	5
90311	60x5	10, 20, 30... pcs.	60	5
Aluminium				
90331	50x4	-	50	6
90332	60x5	-	60	6

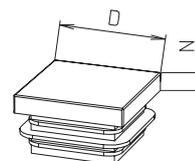

Bouchons filetés carrés

[mm]

Code No.	Type	Tableau des unités de vente	□ D	N
Polyéthylène, noir				
90400	20x1	10, 20, 30... pcs.	20x20	5
90401	25x1,5	10, 20, 30... pcs.	25x25	5
90402	30x2	10, 20, 30... pcs.	30x30	
90403	35x2,5	10, 20, 30... pcs.	35x35	
90404	40x3	10, 20, 30... pcs.	40x40	5
90408	40x4	10, 20, 30... pcs.	40x40	5
90405	50x3	10, 20, 30... pcs.	50x50	
90406	60x4	10, 20, 30... pcs.	60x60	
90407	80x5	10, 20, 30... pcs.	80x80	
Aluminium				
90411	50x3	-	50x50	6

■ **Principe de commande:**
Pièces en acier galvanisées

- Élément de serrage pour tubes Ø et □
- Plage d'écartement pour Ø 21 – 40,5 mm
- Plage d'écartement pour □16,5 – 32 mm

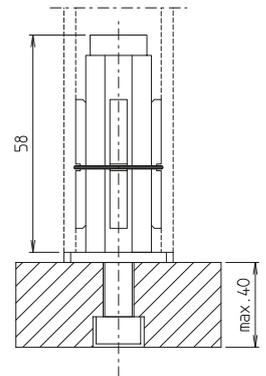

Fixation du tube

[mm]

Code No. DIN 912	Code No. DIN 7991	Ø Type	□ Type
90701	90711	25x2	–
90702	90712	30x2	25x1,5
90702	90712	32x3	–
90702	90712	35x3	–
90705	90715	40x4	30x2
90705	90715	42x4	–
90707	90717	48x4	35x2,5
90708	90718	–	40x3

Principe de commande:

- Pièces articulées en PA noir
- Pièces en acier galvanisées

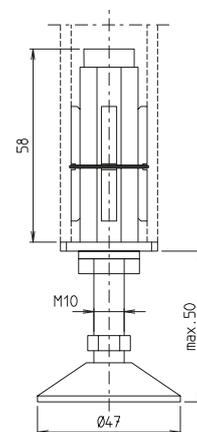

Pied support avec fixation pour tube

[mm]

Code No.	Ø Type	□ Type
90601	25x2	–
90602	30x2	25x1,5
90602	32x3	–
90602	35x3	–
90605	40x4	30x2
90605	42x4	–
90607	48x4	35x2,5
90608	–	40x3

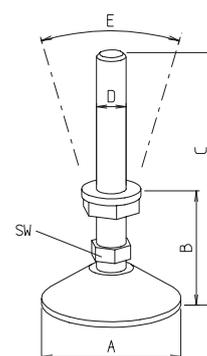

Pied réglable à visser

[mm]

Code No.	A	B	C	D	E	L	SW
90611	47	22	117	M10	30°	117	12
4606301	70	30	130	M16		130	22
4046301	60	39	185	M20	30°	185	16
4046311*	60	42	188			188	16
4046312*	123	70	216			216	16

* Avec amortisseur de vibrations



- Roulette en caoutchouc, largeur 25 mm
- Roulement à billes à portée conique
- Jante en polyamide
- Bandage en caoutchouc bleu-gris
- Pare-fils
- Capacité de charge 600 N

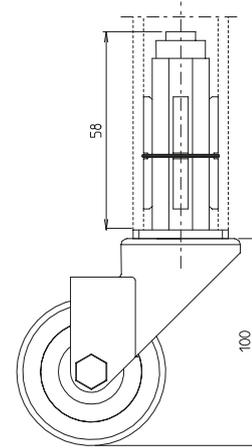

Roues pivotantes pour fixation sur tube et frein à disque

[mm]

Code No.	Ø Type	□ Type
90501	25x2	-
90502	30x2	25x1,5
90502	32x3	-
90502	35x3	-
90505	40x4	30x2
90505	42x4	-
90507	48x4	35x2,5
90508	-	40x3

Remarque : autres modèles disponibles sur demande



- Roulette en caoutchouc, largeur 25 mm
- Roulement à billes à portée conique
- Jante en polyamide
- Bandage en caoutchouc bleu-gris
- Pare-fils
- Capacité de charge 600 N

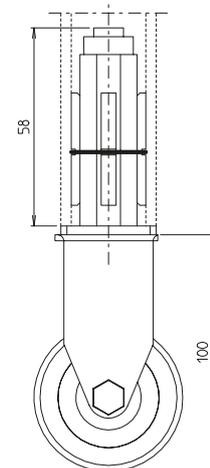

Roues fixes pour fixation sur tube

[mm]

Code No.	Ø Type	□ Type
90802	30x2	25x1,5
90802	32x3	-
90802	35x3	-
90805	40x4	30x2
90805	42x4	-
90807	48x4	35x2,5
90808	-	40x



■ **Principe de fonctionnement :**
Les dimensions et le réglage du levier sont adaptés aux éléments de serrage RK. Pour l'actionner, lever la poignée jusqu'à ce que le mécanisme soit déverrouillé. On obtient ainsi un réglage simple pour serrer et desserrer selon le meilleur angle de serrage. Sous la pression du ressort, le mécanisme se verrouille à nouveau.

■ **Matériaux :**
Poignée en zinc moulé sous pression selon DIN 1743, pièces en acier galvanisées, qualité 5.8.

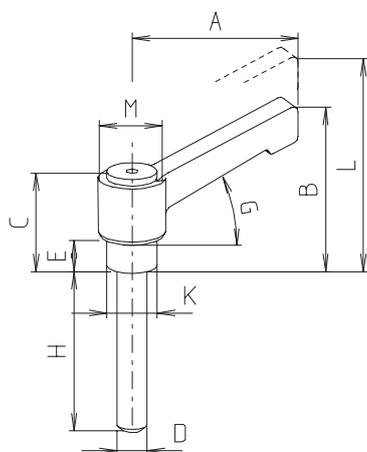

Levier de serrage

[mm]

Code No.	Type	A	B	C	D	E	G	H	K	L	M	m [g]
9020101	HV 5x20	40	33,5	25,5	M5	5,5	20°	20	7,5	37,5	13,5	32
90211	HV 6x10	40	33,5	26,5	M6	6,5	20°	10	10	37,5	13,5	30
90249	HV 6x20							20				-
90210	HV 6x16	40	33,5	26,5	M6	6,5	20°	16	10	37,5	13,5	-
90209	HV 6x18							18				
9021201	HV 6x25	40	33,5	26,5	M6	6,5	20°	25	10	37,5	13,5	34
90247	HV 6x30							30				-
9021301	HV 6x35	40	33,5	26,5	M6	6,5	20°	35	10	37,5	13,5	38
9021401	HV 6x40							40				40
9021501	HV 6x45	65	43,2	29,2	M6	6,5	20°	45	10	47	18	65
9021601	HV 6x55							55				75
9021701	HV 6x60							60				80
90221	HV 8x15	65	45	31	M8	8,5	20°	15	13	49	18	68
9022201	HV 8x25							25				72
9300201	HV 8x30	65	45	31	M8	8,5	20°	30	13	49	18	75
9022401	HV 8x35							35				80
9022501	HV 8x45	65	45	31	M8	8,5	20°	45	13	49	18	86
9022601	HV 8x50							50				91
9022701	HV 8x55	80	53,5	36	M8	8,5	20°	55	13	57,5	22	100
9022801	HV 8x60	65	45	31				60		49	18	
9022901	HV 8x70							70				120
9023001	HV 8x80	80	53,5	36	M8	8,5	20°	80	13	57,5	22	130
9023101	HV 8x90							90				140
9024101	HV 10x20	80	55	37,5	M10	10	20°	20	16	59	26	125
90250	HV 10x30				M11			30				-
90251	HV 10x35	80	55	37,5	M11	10	20°	35	16	59	26	-
90242	HV 10x45				M10			45				140
9024301	HV 10x50	80	55	37,5	M10	10	20°	50	16	59	26	145
9024401	HV 10x60							60				200
9024501	HV 10x70	95	64	42,5	M10	10	20°		16	68	26	
9024601	HV 10x110							110				250
9025501	HV 12x40							40				
9025301	HV 12x45	95	64	42,5	M12	13,5	20°	45	18	68	26	-
9025601	HV 12x80							80				
9027001	HV 16x72	100	72	65	M16	19	20°	72	23	72	33	-

Sure demand:

- Levier avec poignée en plastique
- Levier avec douille fileté en acier inoxydable



- Insert taraudé en acier comme pièce d' de rechange

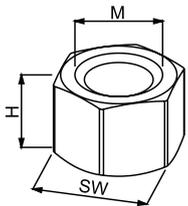

Écrou noyé

[mm]

Code No.	Versions	Type	Tableau des unités de vente	H	M	SW
90732	acier	M6SW8	10, 20, 30... pcs.	5	6	8
90733	acier inoxydable	M6SW8	10, 20, 30... pcs.			
90734	acier	M6SW10	10, 20, 30... pcs.	9	6	10
90736	acier	M8SW11H12	10, 20, 30... pcs.	12	8	11
90738	acier	M8SW11H7	10, 20, 30... pcs.	7	8	11
90739	acier inoxydable	M8SW11H7	10, 20, 30... pcs.			
90740	acier	M10SW14	10, 20, 30... pcs.	10	10	14
90741	acier inoxydable	M10SW14	10, 20, 30... pcs.			



- Montage simple
- Blocage axial et en rotation
- Système et structure existants adaptables
- Contenu de la livraison : Conditionnement (5 pièces)

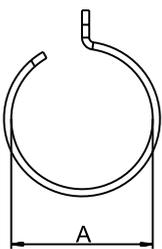

Manchon adaptateur R28

[mm]

Code No.	Version	Tableau des unités de vente	pour Ø A
913131	Typ 1	5, 10, 15... pcs.	28,4 - 28,8
913141	Typ 2	5, 10, 15... pcs.	28,0 - 28,3
913151	Typ 3	5, 10, 15... pcs.	27,5 - 27,9

Les raccords suivants peuvent intégrer le manchon

Solid Clamps	Version
Raccords orthogonaux	K 30, 30x25, 30x20, KD 30x18, 30x16, 30x15, 30x14, 30x12, KR 30, KVR 30
Raccords d'angle	W30, WE 30
Pieds	FS 30
Brides de fixation	FK 30, 30-4
Raccords droits	M 30, MD 30x25
Colliers emboîtables	S 30



- Insert taraudé en acier comme pièce d' de rechange

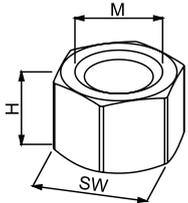

Écrou noyé

[mm]

Code No.	Versions	Type	Tableau des unités de vente	H	M	SW
90732	acier	M6SW8	10, 20, 30... pcs.	5	6	8
90733	acier inoxydable	M6SW8	10, 20, 30... pcs.			
90734	acier	M6SW10	10, 20, 30... pcs.	9	6	10
90736	acier	M8SW11H12	10, 20, 30... pcs.	12	8	11
90738	acier	M8SW11H7	10, 20, 30... pcs.	7	8	11
90739	acier inoxydable	M8SW11H7	10, 20, 30... pcs.			
90740	acier	M10SW14	10, 20, 30... pcs.	10	10	14
90741	acier inoxydable	M10SW14	10, 20, 30... pcs.			



- Montage simple
- Blocage axial et en rotation
- Système et structure existants adaptables
- Contenu de la livraison : Conditionnement (5 pièces)

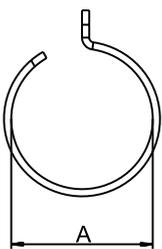

Manchon adaptateur R28

[mm]

Code No.	Version	Tableau des unités de vente	pour Ø A
913131	Typ 1	5, 10, 15... pcs.	28,4 - 28,8
913141	Typ 2	5, 10, 15... pcs.	28,0 - 28,3
913151	Typ 3	5, 10, 15... pcs.	27,5 - 27,9

Les raccords suivants peuvent intégrer le manchon

Solid Clamps	Version
Raccords orthogonaux	K 30, 30x25, 30x20, KD 30x18, 30x16, 30x15, 30x14, 30x12, KR 30, KVR 30
Raccords d'angle	W30, WE 30
Pieds	FS 30
Brides de fixation	FK 30, 30-4
Raccords droits	M 30, MD 30x25
Colliers emboîtables	S 30