

▶▶▶ Secure Industrial Router

Red Lion's RAM 6021 industrial routers provide secure network communication between local and wide area networks.

With a rugged design and flexible platform, the routers provide the ability to remotely connect, monitor and control assets across a variety of industrial applications. Add in robust security features, which include a stateful firewall, NAT translations and VPN connections, and the RAM 6021 delivers a compact all-in-one solution that seamlessly connects to existing Ethernet infrastructures, including networks with Modbus and DNP3 enabled devices.



APPLICATIONS

- > Factory Automation
- > Oil & Gas
- > Water/Wastewater

PRODUCT HIGHLIGHTS

- > Secure network routing and communication
- > LAN-to-LAN or LAN-to-WAN connectivity
- > Intrusion protection through stateful firewall
- > NAT support for 1-to-1 and 1-to-many translations
- > 25 VPN connections for secure remote access
- > Built-in Modbus and DNP3 gateways
- > Rugged industrial design in a compact package

FEATURES & BENEFITS

- > Built-in security and routing protects against unwanted intrusion
 - Intrusion protection and secure data access
 - IPsec and SSL VPN tunnels
 - Port forwarding
 - Stateful firewall
 - Packet filtering
 - Access Control List (ACL)
- > Flexible all-in-one platform reduces complexity
 - Remote TCP/IP based capabilities
 - Integrated switching and routing
 - Serial-to-IP conversion
 - Access IP and serial devices simultaneously
- > Rugged, compact design deploys easily in space-constrained locations
 - -40 to +85°C operating temperature
 - DIN-rail mounting
- > Remote monitoring and control eliminates site visits
 - Instant access to SCADA data
 - Modbus and DNP3 (serial and IP) protocol support
 - Simple integration for complex configurations
 - ID routing to existing Modbus hardware
- > Web-based management simplifies deployment and configuration
 - Remote diagnostics and troubleshooting
 - Key metric reporting

RAM 6021 Specifications

TUNNELING

IPsec and SSL

IP

NAT, port forwarding, dynamic DNS, DHCP
 Stateful inspection firewall, IP transparency
 Routing Protocols
 OSPF, BGP, RIP, VRRP
 Encapsulation Protocols
 GRE

PROTOCOL GATEWAY

Modbus RTU/TCP/ASCII/RTU
 DNP3 - slave

ETHERNET INTERFACE (10/100 AUTO-SENSING)

5x RJ45 (port 5 - WAN/LAN capability)

DATA THROUGHPUT

LAN ports: 100Mbps
 WAN port: 45Mbps

SERIAL INTERFACE

1x RS-232 Serial DB9 115200bps

USB INTERFACE

1x USB 2.0 mini configuration port

MECHANICAL

Dimensions: steel 120 x 96 x 51 mm (4.7" x 3.77" x 2.0")
 Weight: 544g (1.2 lbs)

REDUNDANT POWER INPUT

4-pin screw terminal
 Side mounted 2.5mm barrel connector
 8-30 Vdc (12 Vdc nominal)
 Input current (max): 150mA

ENVIRONMENTAL

Operating temperature: -40° to +85°C
 Shock: IEC60068-2-27
 Vibration: IEC60068-2-6
 Humidity: 5 to 95% non-condensing

CERTIFICATION

CE, EMC: FCC, part 15 and Industry Canada, ICES-003
 Hazardous locations: Class I, Div. 2, Groups A, B, C, D, ISA 12.12.01
 Electrical safety: UL508/CSA22.2/14 (CUL)

INPUTS & OUTPUTS

1x digital output
 1x digital/analog input (one active)

WARRANTY

3 years on design and manufacturing defects

All specifications are subject to change. Consult the company website for more information.

ORDERING GUIDE

PART NUMBER	DESCRIPTION
RAM-6021	Secure router with 5 Ethernet ports, 1 serial port, Modbus/DNP3 gateway
ET-PS-024-02	DIN rail 2 amp power supply
FPSALACADAPTER2	2.5mm barrel power supply

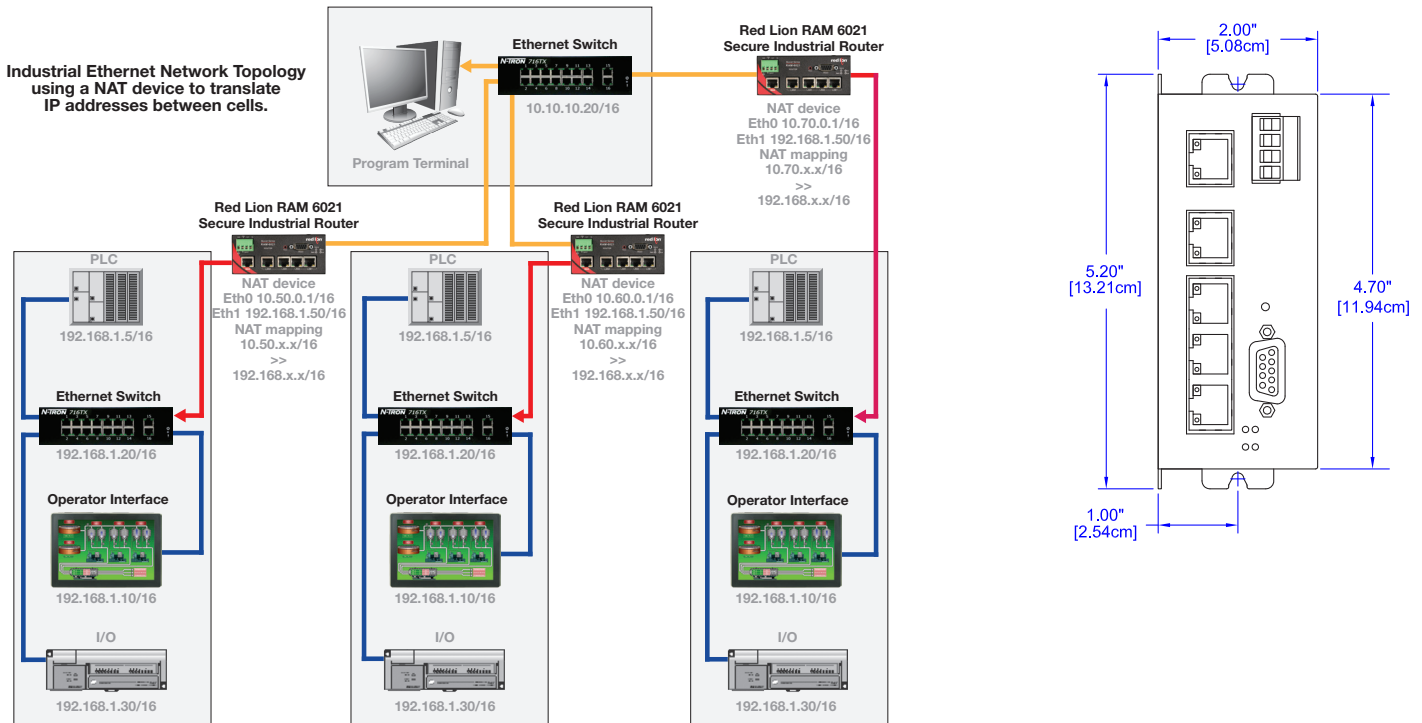

www.redlion.net

Connect. Monitor. Control.

Americas
 sales@redlion.net

Asia-Pacific
 asia@redlion.net

Europe
Middle East
Africa
 europe@redlion.net

+1 (717) 767-6511

As the global experts in communication, monitoring and control for industrial automation and networking, Red Lion has been delivering innovative solutions for over forty years. Our award-winning technology enables companies worldwide to gain real-time data visibility that drives productivity. Product brands include Red Lion, N-Tron and Sixnet. With headquarters in York, Pennsylvania, the company has offices across the Americas, Asia-Pacific and Europe. For more information, please visit www.redlion.net. Red Lion is a Spectris company.