

CY SERIES

Amplifier Built-in Cylindrical Photoelectric Sensor

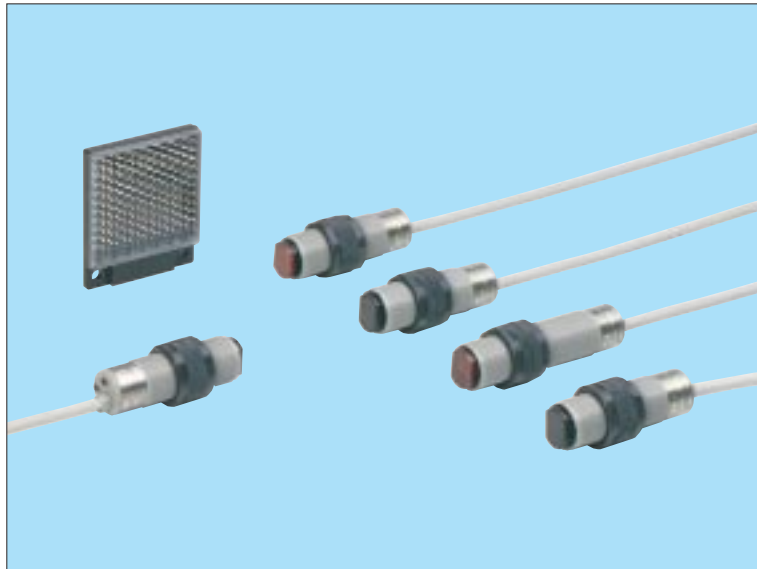

Cylindrical Type Easily Mountable with M18 Thread

CE Marked

Conforming to EMC Directive
(AC supply type conforms to)
Low Voltage Directive, too.)

EQ-20

EQ-30

EX-40

RX

RX-LS200

CY

EX

PX-2

RT-610

Amplifier Built-in Type

M18 Thread

This sensor has an M18 thread size for convenient mounting.

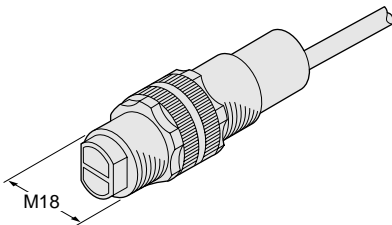

Easy to Replace

A pigtailed type sensor with connector (CY-□-J), which is easy to replace, is also available.

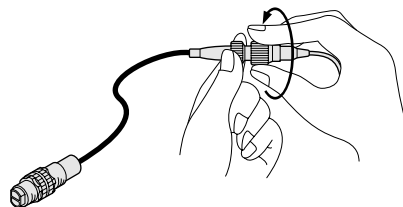

Long Sensing Range

Thru-beam type

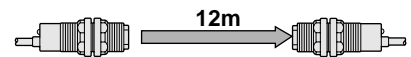

Retroreflective type

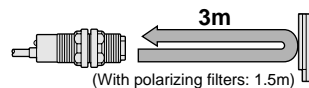

Diffuse reflective type

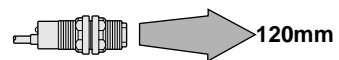

Wide Product Range

Supply voltage

- ① AC supply type (24 to 240V AC)
- ② DC supply type (10 to 30V DC)

Output

- ① NPN open-collector transistor
- ② PNP open-collector transistor
- ③ AC non-contact (thyristor) output

Connection

- ① Cable type
- ② Pigtailed type

A total of 32 models are available.

Environment Resistant

Its IP67 construction can be hosed down with water. In addition, it has strong resistance against vibration since it is filled up with resin.

The connector also has IP67 protection.



Note: However, take care that if it is exposed to water splashes during operation, it may detect a water drop itself.

Convenient Options

Side-view attachment (For thru-beam type sensors only)

The beam is bent at a right angle with the side-view attachment.



Slit mask (For thru-beam type sensors only)

It is convenient for detecting small objects or enhancing the sensing accuracy.



APPLICATIONS

Sensing cardboard boxes

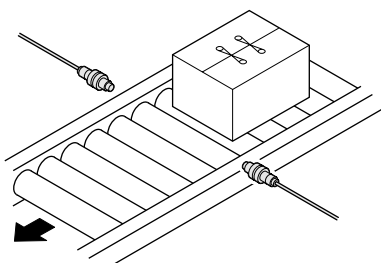

Sensing specular objects

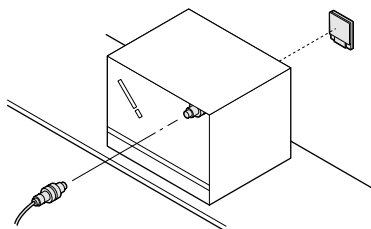

Sensing milk packs

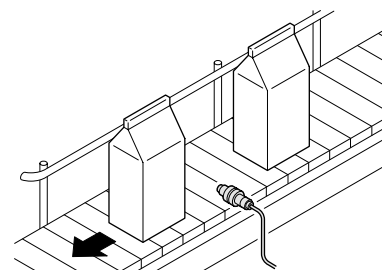

ORDER GUIDE

Type	Appearance	Sensing range	Model No.	Supply voltage	Output	Output operation
DC supply type	Thru-beam	12m	CY-21	10 to 30V DC	NPN open-collector transistor	Selectable either Light-ON or Dark-ON by the control input
			CY-21-PN		PNP open-collector transistor	
	Retroreflective	3m (Note 1)	CY-27		NPN open-collector transistor	
			CY-27-PN		PNP open-collector transistor	
	With polarizing filters	1.5m (Note 1)	CY-29		NPN open-collector transistor	
			CY-29-PN		PNP open-collector transistor	
Diffuse reflective	120mm	CY-22	NPN open-collector transistor			
		CY-22-PN	PNP open-collector transistor			
AC supply type	Thru-beam	12m	CY-11A	24 to 240V AC ± 10%	AC non-contact (thyristor) output	Light-ON
			CY-11B			Dark-ON
	Retroreflective	3m (Note 1)	CY-17A			Light-ON
			CY-17B			Dark-ON
	With polarizing filters	1.5m (Note 1)	CY-19A			Light-ON
			CY-19B			Dark-ON
	Diffuse reflective	120mm	CY-12A			Light-ON
			CY-12B			Dark-ON

NOTE: Reflector is not supplied with the retroreflective type sensor. Please select the suitable reflector or reflective tape from the options.

Note 1: The sensing range of the retroreflective type sensor is specified for the RF-230 reflector (optional).

Amplifier Built-in Type

EQ-20

EQ-30

EX-40

RX

RX-LS200

CY

EX

PX-2

RT-610

ORDER GUIDE

Pigtailed type

Pigtailed sensors are available. When ordering this type, add suffix '-J' to the model No. Please order the suitable mating cable separately.
(e.g.) The pigtailed type of **CY-22-PN** is '**CY-22-PN-J**'.

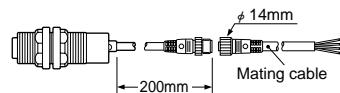

• Mating cable

Type	Model No.	Description	
For DC supply type (Note 1)	CN-22-C2	Length: 2m	• For the emitter of the thru-beam type sensor (2-core) (Note 2)
	CN-22-C5	Length: 5m	
	CN-24-C2	Length: 2m	• For the receiver of the thru-beam type sensor, retroreflective type and diffuse reflective type sensors (4-core) (Note 2)
	CN-24-C5	Length: 5m	
For AC supply type (Note 1)	CN-32-C2	Length: 2m	• For the emitter of the thru-beam type sensor (2-core)
	CN-32-C5	Length: 5m	
	CN-33-C2	Length: 2m	• For the receiver of the thru-beam type sensor, retroreflective type and diffuse reflective type sensors (3-core)
	CN-33-C5	Length: 5m	

Notes: 1) The DC supply type mating cable and the AC supply type mating cable have different connector structure and so are not interchangeable.

2) To use the test input, use the 4-core **CN-24-C**.

OPTIONS

Designation	Model No.	Description		
Slit mask (For thru-beam type sensor only)	OS-CYS	Slit size 11.6 × 0.5mm	Slit on emitter • Sensing range: 3m • Min. sensing object: ϕ 8mm	
			Slit on receiver • Sensing range: 2.5m • Min. sensing object: ϕ 8mm	
			Slit on both sides • Sensing range: 0.8m • Min. sensing object: 10 × 0.7mm	
		Slit size 11.6 × 1.5mm	Slit on emitter • Sensing range: 5m • Min. sensing object: ϕ 8mm	
			Slit on receiver • Sensing range: 4.5m • Min. sensing object: ϕ 8mm	
			Slit on both sides • Sensing range: 2m • Min. sensing object: 10 × 2mm	
	Slit size 11.6 × 3mm	Slit on emitter • Sensing range: 7.5m • Min. sensing object: ϕ 8mm		
		Slit on receiver • Sensing range: 7m • Min. sensing object: ϕ 8mm		
		Slit on both sides • Sensing range: 4.5m • Min. sensing object: 10 × 3mm		
	Side-view attachment (For thru-beam type sensor only)	CY-SV1	• The beam is bent at a right angle by the attachments. • Sensing range (with slit on both sides): 8m	
	Reflector (For retroreflective type sensor only)	RF-230	• Sensing range: 3m [CY-27□ & CY-17□], 1.5m [CY-29□ & CY-19□]	
		RF-220	• Sensing range: 2m [CY-27□ & CY-17□], 1.2m [CY-29□ & CY-19□]	
RF-210		• Sensing range: 1m [CY-27□ & CY-17□], 0.7m [CY-29□ & CY-19□]		
Reflector mounting bracket	MS-RF21-1	Protective mounting bracket for RF-210 It protects the reflector from damage and maintains alignment.		
	MS-RF22	For RF-220		
	MS-RF23	For RF-230		
Reflective tape (For retroreflective type sensor only)	RF-12	• Sensing range: 0.7m [CY-27□ & CY-17□], 0.4m [CY-29□ & CY-19□]		
	RF-11	• Sensing range: 0.5m [CY-27□ & CY-17□]		
Sensor checker (Note)	CHX-SC2	It is useful for beam alignment of thru-beam type sensors. The optimum receiver position is given by indicators, as well as, an audio signal.		

Note: Refer to P.378~ for details on the sensor checker **CHX-SC2**.

Slit mask



Side-view attachment

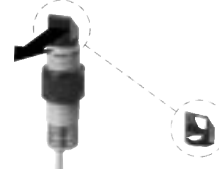

Reflector

• RF-230

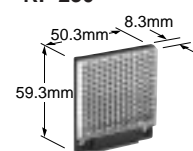

• RF-220

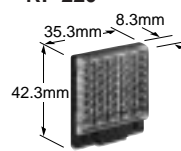

• RF-210

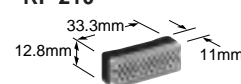

Reflective tape

• RF-12

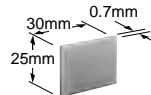

• RF-11

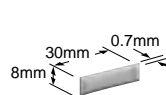

Reflector mounting bracket

• MS-RF23

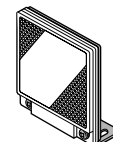

Two M4 (length 10mm) screws with washers are attached.

• MS-RF22

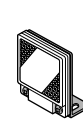

Two M3 (length 8mm) screws with washers are attached.

• MS-RF21-1



Two M3 (length 12mm) screws with washers are attached.

Sensor checker

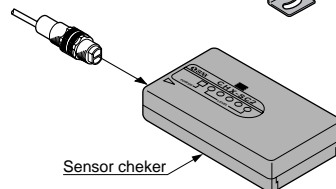

Sensor checker

SPECIFICATIONS

DC supply type

Item	Model No.	Type	Thru-beam		Retroreflective		Diffuse reflective
					With polarizing filters		
			NPN output type	CY-21	CY-27	CY-29	CY-22
PNP output type	CY-21-PN	CY-27-PN	CY-29-PN	CY-22-PN			
Sensing range			12m	3m (Note 1)	1.5m (Note 1)	120mm (Note 2)	
Sensing object			φ8mm or more opaque object	φ50mm or more opaque or translucent object (Note 1)	φ50mm or more opaque, translucent or specular object (Note 1)	Opaque, translucent or transparent object	
Hysteresis			—————			15% or less of operation distance	
Repeatability (perpendicular to sensing axis)			0.1mm or less			0.3mm or less	
Supply voltage			10 to 30V DC Ripple P-P 10% or less				
Current consumption			Emitter: 20mA or less Receiver: 25mA or less	25mA or less			
Output			<NPN output type> NPN open-collector transistor • Maximum sink current: 100mA • Applied voltage: 30V DC or less (between output and 0V) • Residual voltage: 1.5V or less (at 100mA sink current)		<PNP output type> PNP open-collector transistor • Maximum source current: 100mA • Applied voltage: 30V DC or less (between output and +V) • Residual voltage: 1.5V or less (at 100mA source current)		
Utilization category			DC-12 or DC-13				
Output operation			Selectable either Light-ON or Dark-ON by the control input				
Short-circuit protection			Incorporated				
Response time			2ms or less				
Test input function			Incorporated	—————			
Operation indicator			Red LED (lights up when the output is ON)				
Emission indicator			Red LED (lights up during beam emission)	—————			
Environmental resistance	Pollution degree		3 (Industrial environment)				
	Protection		IP67 (IEC)				
	Ambient temperature		- 25 to + 55°C (No dew condensation or icing allowed), Storage: - 30 to + 70°C				
	Ambient humidity		35 to 85% RH, Storage: 35 to 85% RH				
	Ambient illuminance		Sunlight: 10,000ℓx at the light-receiving face, Incandescent light: 3,000ℓx at the light-receiving face				
	EMC		Emission: EN50081-2, Immunity: EN50082-2				
	Voltage withstandability		1,000V AC for one min. between all supply terminals connected together and enclosure				
	Insulation resistance		20MΩ, or more, with 250V DC megger between all supply terminals connected together and enclosure				
	Vibration resistance		10 to 500Hz frequency, 1.5mm amplitude (10G max.) in X, Y and Z directions for two hours each				
Shock resistance		500m/s ² acceleration (50G approx.) in X, Y and Z directions for three times each					
Emitting element			Infrared LED (modulated)	Red LED (modulated)	Infrared LED (modulated)		
Material			Enclosure: PBT, Lens: Polycarbonate	Enclosure: PBT, Front cover: Acrylic			
Cable			0.34mm ² 4-core (thru-beam type emitter: 3-core) cabtyre cable, 2m long				
Cable extension			Extension up to total 100m is possible with 0.34mm ² , or more, cable (thru-beam type: both emitter and receiver).				
Weight			Emitter: 90g approx. Receiver: 100g approx.	100g approx.			
Accessories			Nut: 4 Nos.	Nut: 2 Nos.			

NOTE: Reflector is not supplied with the retroreflective type sensor. Please select the suitable reflector or reflective tape from the options.

Notes: 1) The sensing range and the sensing object of the retroreflective type sensor are specified for the **RF-230** reflector (optional).
2) The sensing range of the diffuse reflective type sensor is specified for white non-glossy paper (200 × 200mm) as the object.

EQ-20

EQ-30

EX-40

RX

Amplifier Built-in Type

RX-LS200

CY

EX

PX-2

RT-610

SPECIFICATIONS

AC supply type

Item	Model No.	Type	Retroreflective			Diffuse reflective
			Thru-beam	With polarizing filters		
				CY-11A	CY-17A	
			CY-11B	CY-17B	CY-19B	CY-12A
						CY-12B
Sensing range		12m	3m (Note 1)	1.5m (Note 1)	120mm (Note 2)	
Sensing object		φ 8mm or more opaque object	φ 50mm or more opaque or translucent object (Note 1)	φ 50mm or more opaque, translucent or specular object (Note 1)	Opaque, translucent or transparent object	
Hysteresis		—————				15% or less of operation distance
Repeatability (perpendicular to sensing axis)		0.1mm or less				0.3mm or less
Supply voltage		24 to 240V AC ± 10%				
Power consumption		Emitter: 1.5VA or less Receiver: 2.5VA or less	2.7VA or less			
Output		AC non-contact (thyristor) output • Load current: 5 to 200mA • Applied voltage: 24 to 240V AC ± 10% • Residual voltage: 4V AC or less (at 200mA load current)				
Response time		20ms or less				
Operation indicator		Red LED (lights up when the output is ON), incorporated on the receiver for the thru-beam type sensor				
Power indicator		Red LED (lights up when the power is ON), incorporated on the emitter	—————			
Environmental resistance	Protection	IP67 (IEC)				
	Ambient temperature	- 25 to + 55°C (No dew condensation or icing allowed), Storage: - 30 to + 70°C				
	Ambient humidity	35 to 85% RH, Storage: 35 to 85% RH				
	Ambient illuminance	Sunlight: 10,000 lx at the light-receiving face, Incandescent light: 3,000 lx at the light-receiving face				
	EMC	Emission: EN50081-2, Immunity: EN50082-2				
	Voltage withstandability	1,500V AC for one min. between all supply terminals connected together and enclosure				
	Insulation resistance	20MΩ, or more, with 500V DC megger between all supply terminals connected together and enclosure				
	Vibration resistance	10 to 500Hz frequency, 1.5mm amplitude (10G max.) in X, Y and Z directions for two hours each				
Shock resistance	500m/s ² acceleration (50G approx.) in X, Y and Z directions for three times each					
Emitting element		Infrared LED (modulated)	Red LED (modulated)	Infrared LED (modulated)		
Material		Enclosure: PBT, Lens: Polycarbonate	Enclosure: PBT, Front cover: Acrylic			
Cable		0.34mm ² 3-core (thru-beam type emitter: 2-core) cabtyre cable, 2m long				
Cable extension		Extension up to total 100m is possible with 0.34mm ² , or more, cable (thru-beam type: both emitter and receiver).				
Weight		Emitter: 90g approx. Receiver: 100g approx.	100g approx.			
Accessories		Nut: 4 Nos.	Nut: 2 Nos.			

NOTE: Reflector is not supplied with the retroreflective type sensor. Please select the suitable reflector or reflective tape from the options.

Notes: 1) The sensing range and the sensing object of the retroreflective type sensor are specified for the **RF-230** reflector (optional).
2) The sensing range of the diffuse reflective type sensor is specified for white non-glossy paper (200 × 200mm) as the object.

I/O CIRCUIT AND WIRING DIAGRAMS

NPN output type

I/O circuit diagram

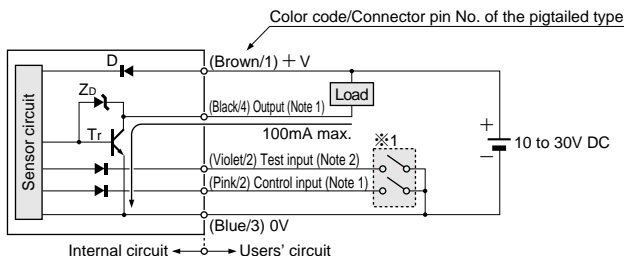

- Notes: 1) The emitter of the thru-beam type sensor does not incorporate the output and the control input. When the mating cable is connected to the pigtailed type, the color of the control input wire is white.
- 2) Incorporated only on the emitter of the thru-beam type sensor. When the mating cable is connected to the pigtailed type, its color is white.

Symbols ... D: Reverse supply polarity protection diode
Z_D: Surge absorption zener diode
Tr: NPN output transistor

Wiring diagram

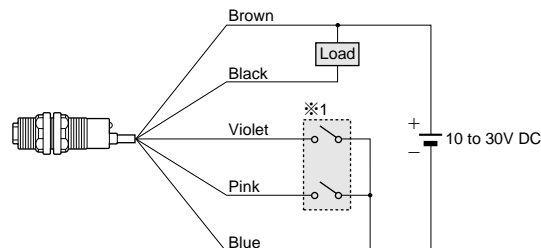

Connector pin position (Pigtailed type)

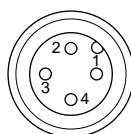

- 1: +V
2: Test input or control input
3: 0V
4: Output or not connected

※1

Non-voltage contact or NPN open-collector transistor

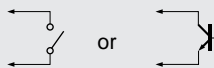

- **Test input**
Low (0 to 2.5V): emission stopped
High (6 to 30V or open): emission
- **Control input**
Low (0 to 1.5V): Dark-ON
High (6 to 30V, or open): Light-ON

PNP output type

I/O circuit diagram

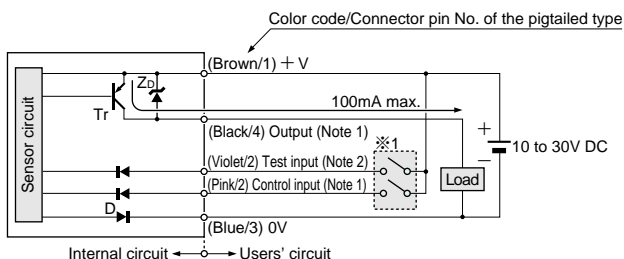

- Notes: 1) The emitter of the thru-beam type sensor does not incorporate the output and the control input. When the mating cable is connected to the pigtailed type, the color of the control input wire is white.
- 2) Incorporated only on the emitter of the thru-beam type sensor. When the mating cable is connected to the pigtailed type, its color is white.

Symbols ... D: Reverse supply polarity protection diode
Z_D: Surge absorption zener diode
Tr: PNP output transistor

Wiring diagram

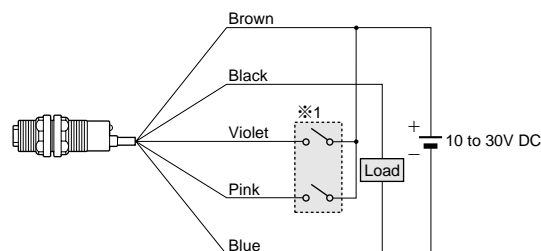

Connector pin position (Pigtailed type)

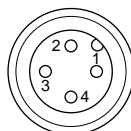

- 1: +V
2: Test input or control input
3: 0V
4: Output or not connected

※1

Non-voltage contact or PNP open-collector transistor

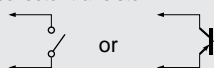

- **Test input**
Low (0 to 1.5V, or open): emission
High (3 to 30V): emission stopped
- **Control input**
Low [(supply voltage - 6V) or less, or open]: Light-ON
High [(supply voltage - 1.5V) or more]: Dark-ON

I/O CIRCUIT AND WIRING DIAGRAMS

AC non-contact output type

I/O circuit diagrams

Emitter of thru-beam type sensor

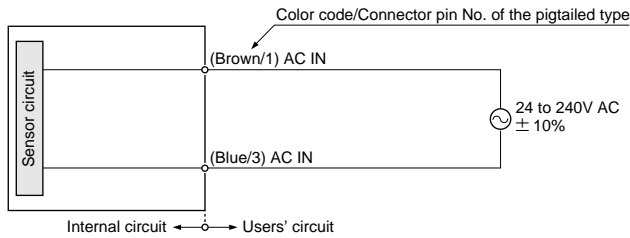

Receiver of thru-beam type sensor, retroreflective & diffuse reflective type sensors

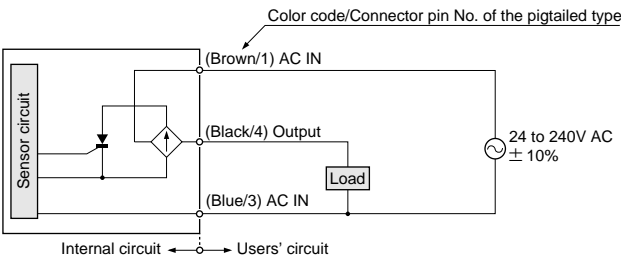

Wiring diagrams

Emitter of thru-beam type sensor

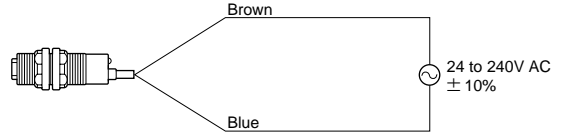

Receiver of thru-beam type sensor, retroreflective & diffuse reflective type sensors

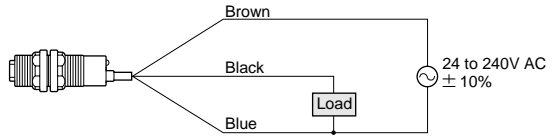

Connector pin position (Pigtailed type)

Emitter of thru-beam type sensor

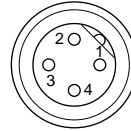

- 1: AC IN
- 2: Not connected
- 3: AC IN
- 4: Not connected

Receiver of thru-beam type sensor, retroreflective & diffuse reflective type sensors

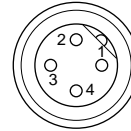

- 1: AC IN
- 2: Not connected
- 3: AC IN
- 4: Output

SENSING CHARACTERISTICS (TYPICAL)

All models

Correlation between setting distance and excess gain

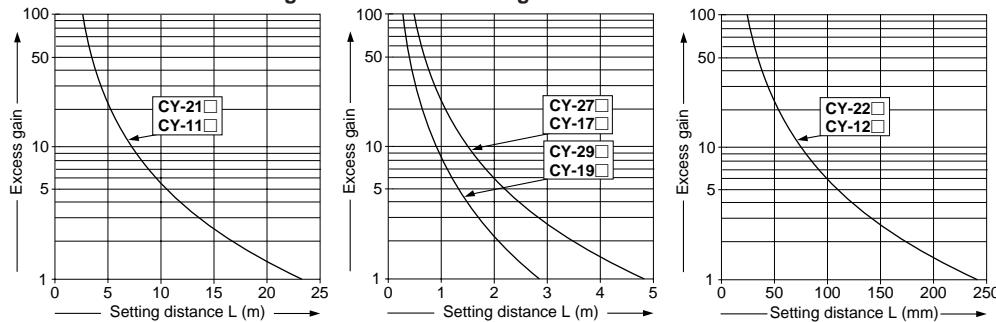

CY-21
CY-11

Thru-beam type

CY-27
CY-17

Retroreflective type

Parallel deviation

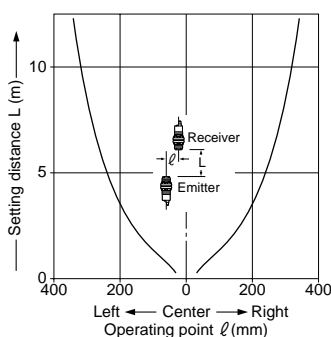

Angular deviation

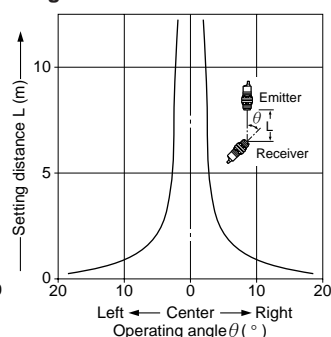

Parallel deviation

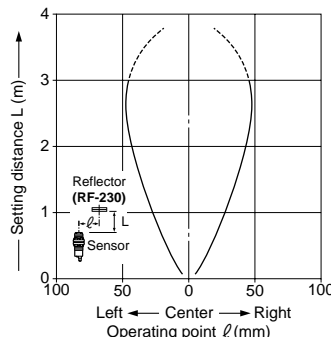

Angular deviation

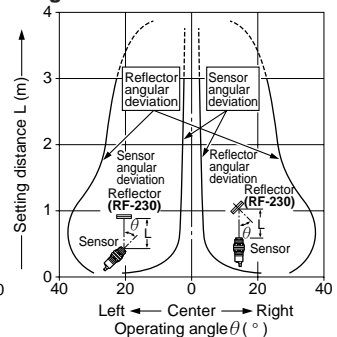

SENSING CHARACTERISTICS (TYPICAL)

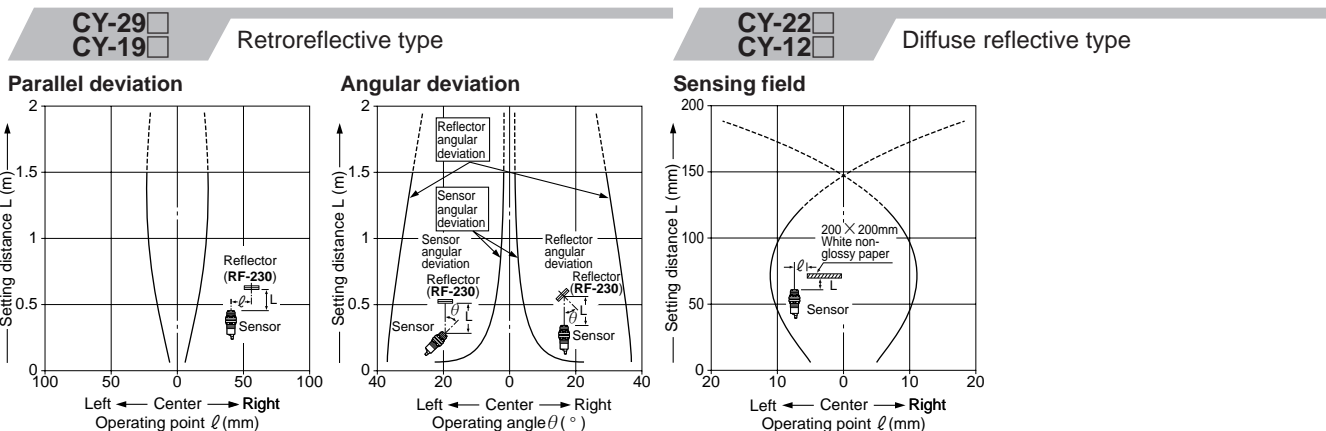

PRECAUTIONS FOR PROPER USE

Refer to P.820~ for general precautions.

This product is not a safety sensor. Its use is not intended or designed to protect life and prevent body injury or property damage from dangerous parts of machinery. It is a normal object detection sensor.

Mounting

- The tightening torque should be 2N·m or less.

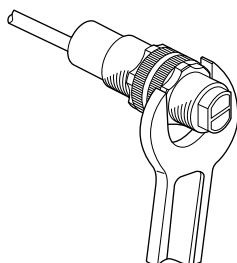

Retroreflective type sensor with polarizing filters (CY-29□ and CY-19□)

- If a shiny object is covered or wrapped with a transparent film, such as those described below, the retroreflective type sensor with polarizing filters may not be able to detect it.

In that case, follow the steps given below.

Example of sensing objects

- Can wrapped by clear film
- Aluminum sheet covered by plastic film
- Gold or silver color (glossy) label or wrapping paper

Steps

- Tilt the sensor with respect to the sensing object while fitting.
- Increase the distance between the sensor and the sensing object.

Retroreflective type sensor (CY-27□ and CY-17□)

- Please take care of the following points when detecting materials having a gloss.

- Make L, shown in the diagram, sufficiently long.
- Install at an angle of 10 to 30 degrees to the sensing object.

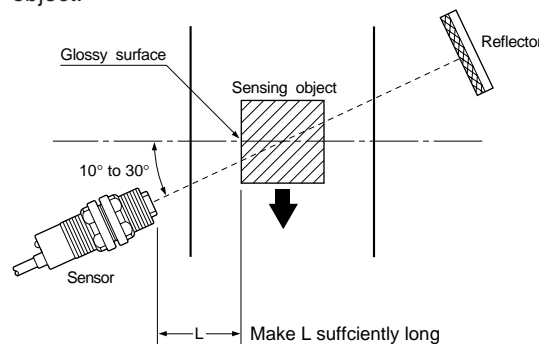

※CY-29□ and CY-19□ do not need the above adjustment.

Others

- Do not use during the initial transient time (50ms) after the power supply is switched on.

EQ-20

EQ-30

EX-40

RX

Amplifier Built-in Type
RX-LS200

CY

EX

PX-2

RT-610

DIMENSIONS (Unit: mm)

CY-21 **CY-27**
CY-22 Sensor

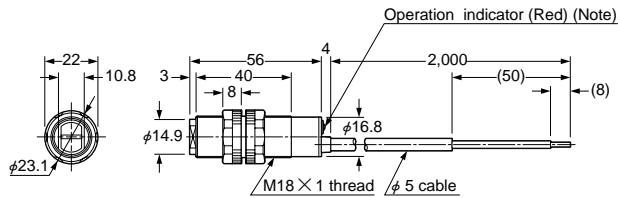

Note: It is the emitting indicator (red) on the emitter of the thru-beam type sensor.

CY-21-J **CY-27-J**
CY-22-J Sensor

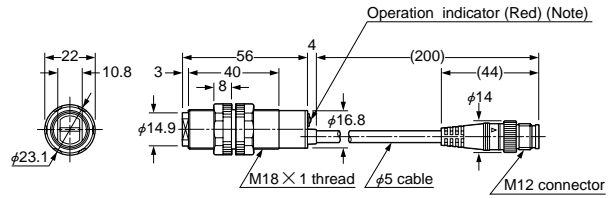

Note: It is the emitting indicator (red) on the emitter of the thru-beam type sensor.

CY-29 Sensor

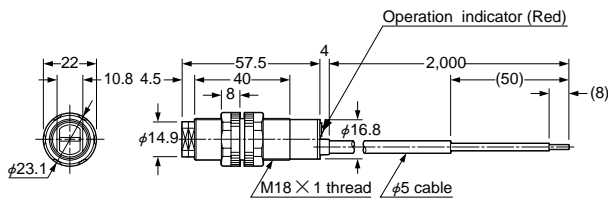

CY-29-J Sensor

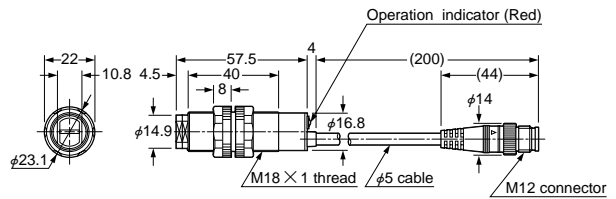

CY-11 **CY-17**
CY-12 Sensor

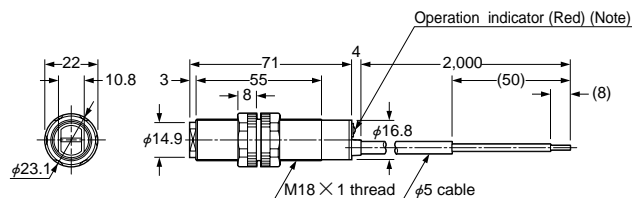

Note: It is the power indicator (red) on the emitter of the thru-beam type sensor.

CY-11-J **CY-17-J**
CY-12-J Sensor

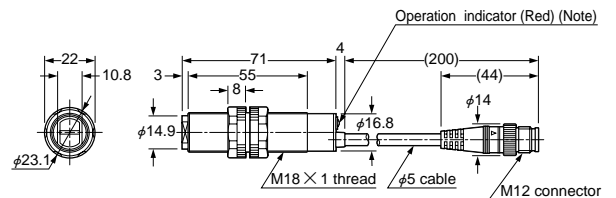

Note: It is the power indicator (red) on the emitter of the thru-beam type sensor.

CY-19 Sensor

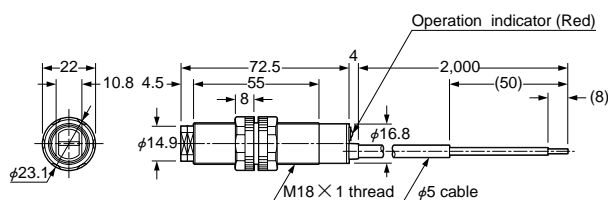

CY-19-J Sensor

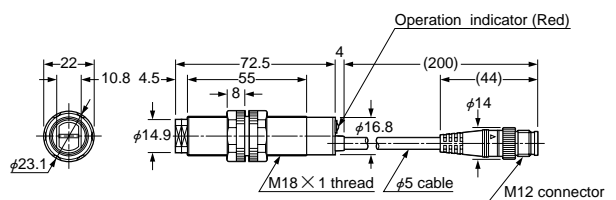

RF-210 Reflector (Optional)

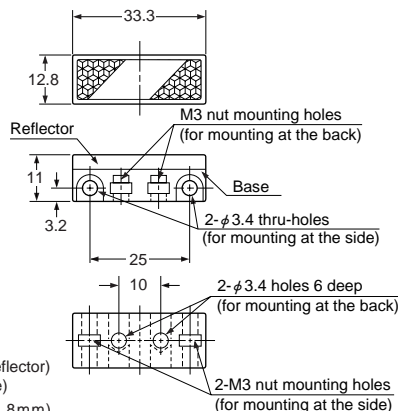

Material: Acrylic (Reflector)
ABS (Base)
Two M3 (length 8mm)
screws with washers and
two nuts are attached.

RF-220 Reflector (Optional)

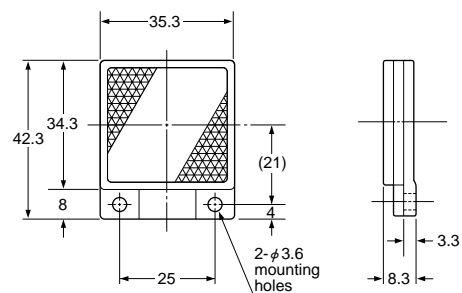

Material: Acrylic (Reflector)
ABS (Base)

DIMENSIONS (Unit: mm)

RF-230 Reflector (Optional)

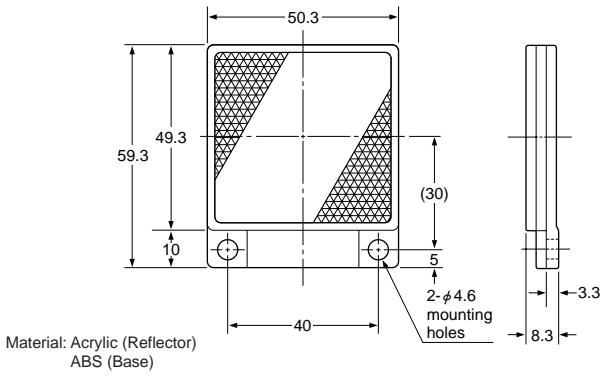

RF-11 Reflective tape (Optional)

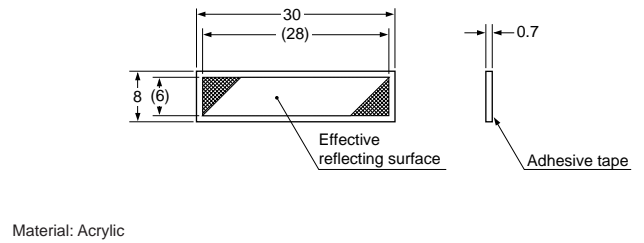

RF-12 Reflective tape (Optional)

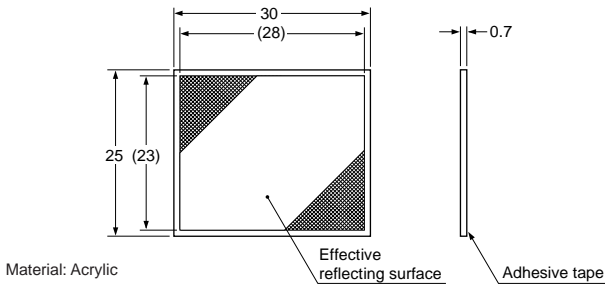

MS-RF21-1 Reflector mounting bracket for RF-210 (Optional)

Assembly dimensions

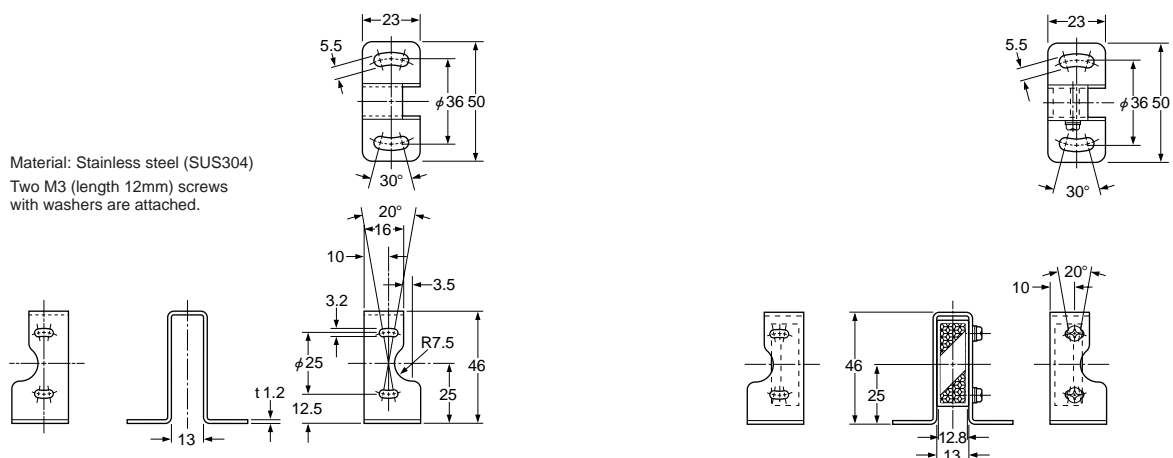

EQ-20

EQ-30

EX-40

RX

Amplifier Built-in Type

RX-LS200

CY

EX

PX-2

RT-610

DIMENSIONS (Unit: mm)

MS-RF22 Reflector mounting bracket for RF-220 (Optional)

Assembly dimensions

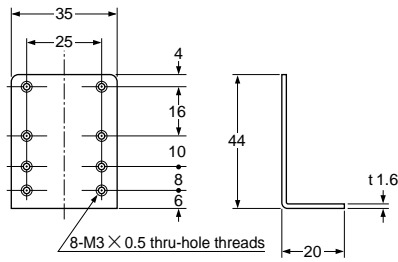
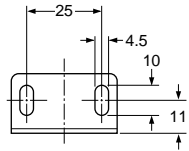

Material: Cold rolled carbon steel (SPCC)
(Uni-chrome plated)
Two M3 (length 8mm) screws with washers are attached.

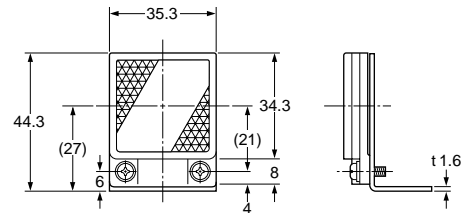
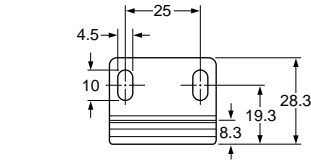

MS-RF23 Reflector mounting bracket for RF-230 (Optional)

Assembly dimensions

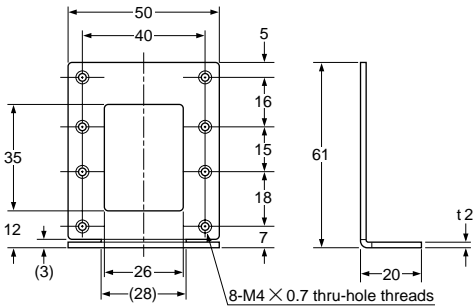
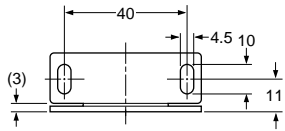

Material: Cold rolled carbon steel (SPCC)
(Uni-chrome plated)
Two M4 (length 10mm) screws with washers are attached.

