

CMOS type

Micro Laser Distance Sensor

HG-C SERIES

HG-C1000L SERIES IO-Link Compatible, Self-monitoring Type



Reliable detection
in repeatability $10\ \mu\text{m}$ **0.394 mil***

*HG-C1030□

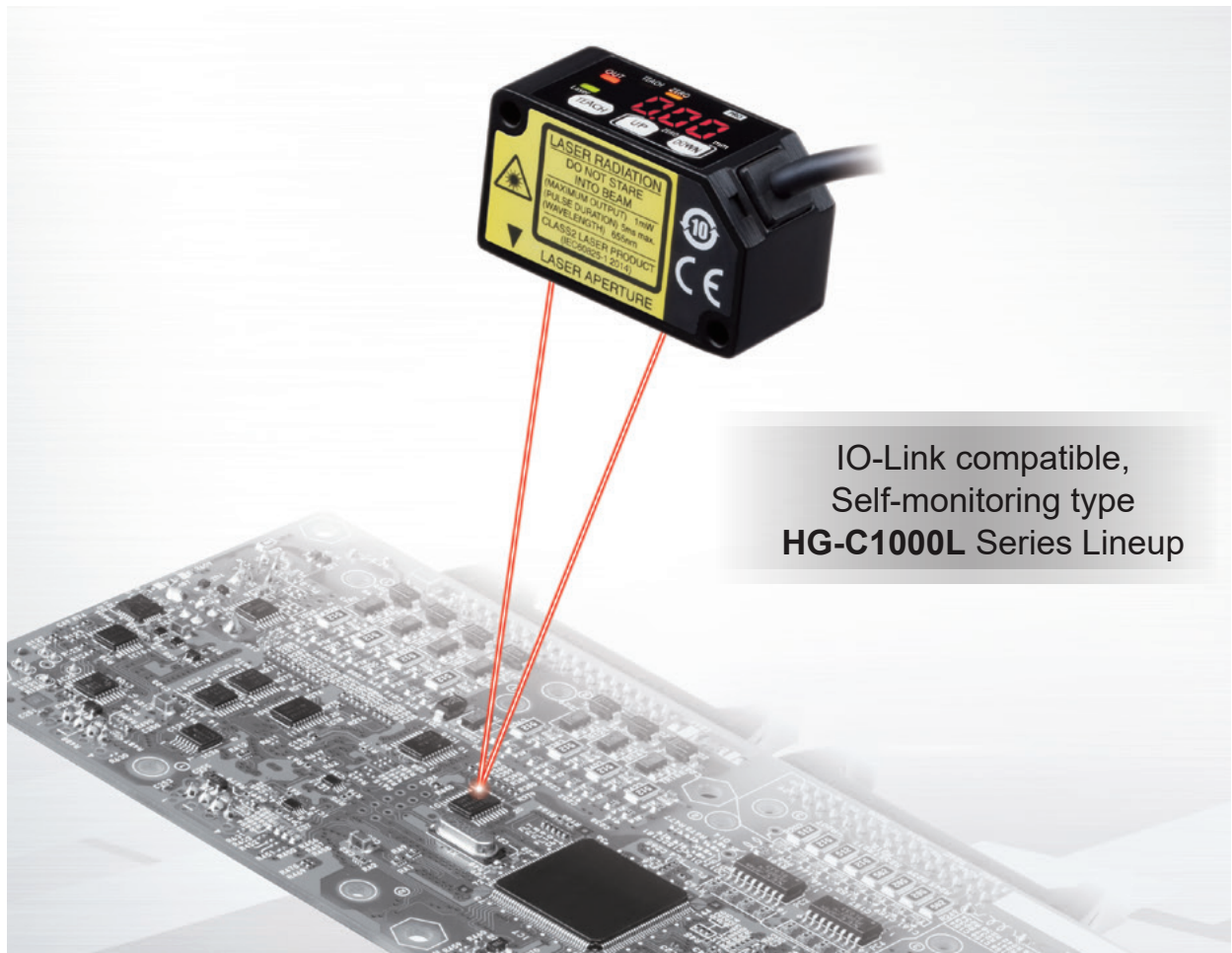

IO-Link compatible,
Self-monitoring type
HG-C1000L Series Lineup

HG-C SERIES

Repeatability
10 μm 0.394 mil
 *HG-C1030□

Dimensions
W20 × H44 × D25 mm
W0.787 × H1.732 × D0.984 in

Inflection resistant cable
HG-C1□0(-P)
are adopted.

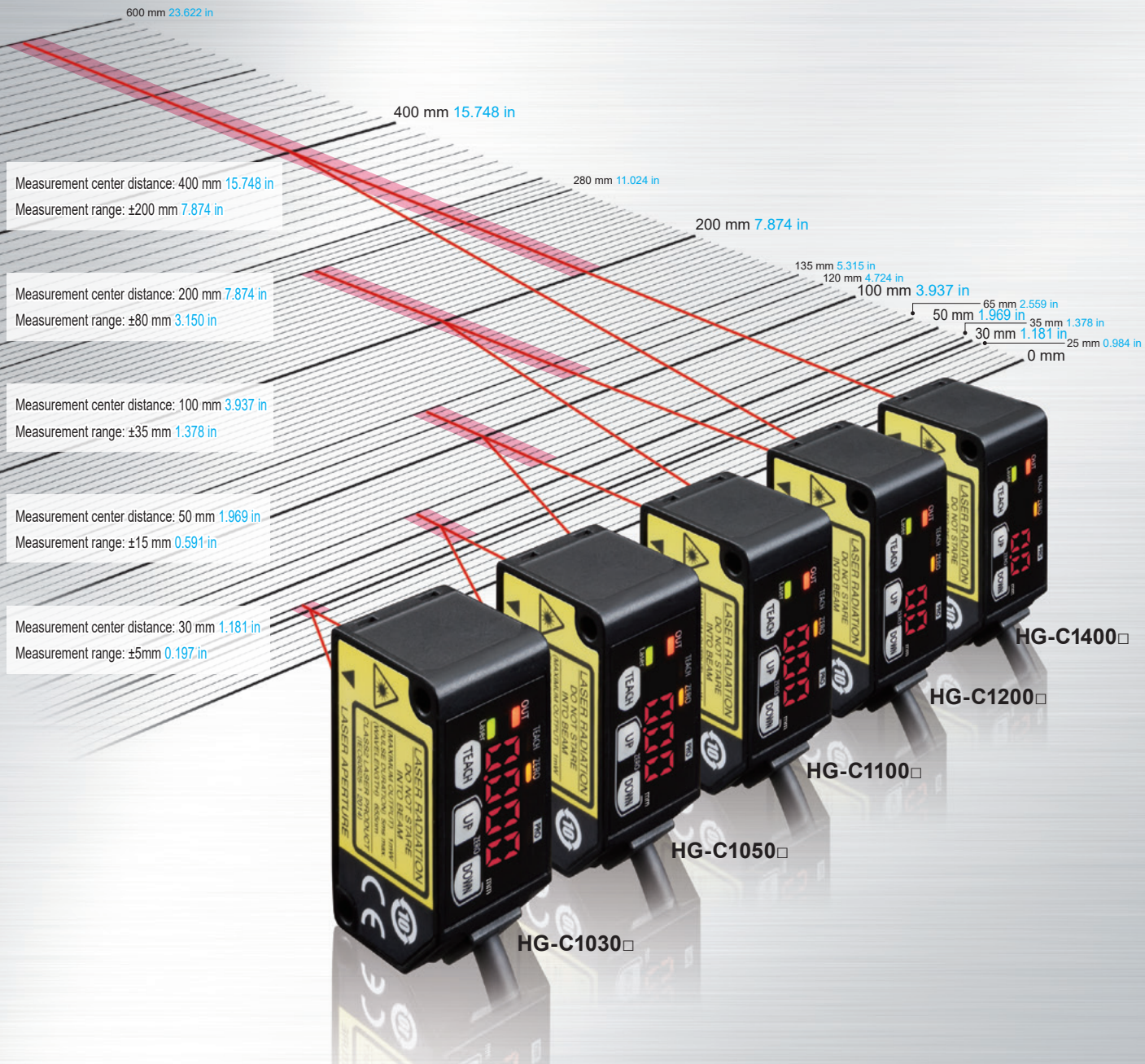

Item	Model No.	HG-C1030□	HG-C1050□	HG-C1100□	HG-C1200□	HG-C1400□
Measurement center distance		30 mm 1.181 in	50 mm 1.969 in	100 mm 3.937 in	200 mm 7.874 in	400 mm 15.748 in
Measurement range		±5 mm 0.197 in	±15 mm 0.591 in	±35 mm 1.378 in	±80 mm 3.150 in	±200 mm 7.874 in
Beam diameter		ø50 μm 1.969 mil approx.	ø70 μm 2.756 mil approx.	ø120 μm 4.724 mil approx.	ø300 μm 11.811 mil approx.	ø500 μm 19.685 mil approx.
Repeatability		10 μm 0.394 mil	30 μm 1.181 mil	70 μm 2.756 mil	200 μm 7.874 mil	300 μm 11.811 mil (Measuring distance 200 to 400 mm 7.874 to 15.748 in) 800 μm 31.496 mil (Measuring distance 400 to 600 mm 15.748 to 23.622 in)

Overwhelmingly stable

Precise measurements on the order of 1/100 mm **0.0003 inch***

*HG-C1030□

Excellent level detection performance

Repeatability: 10 μm **0.394 mil** *HG-C1030□

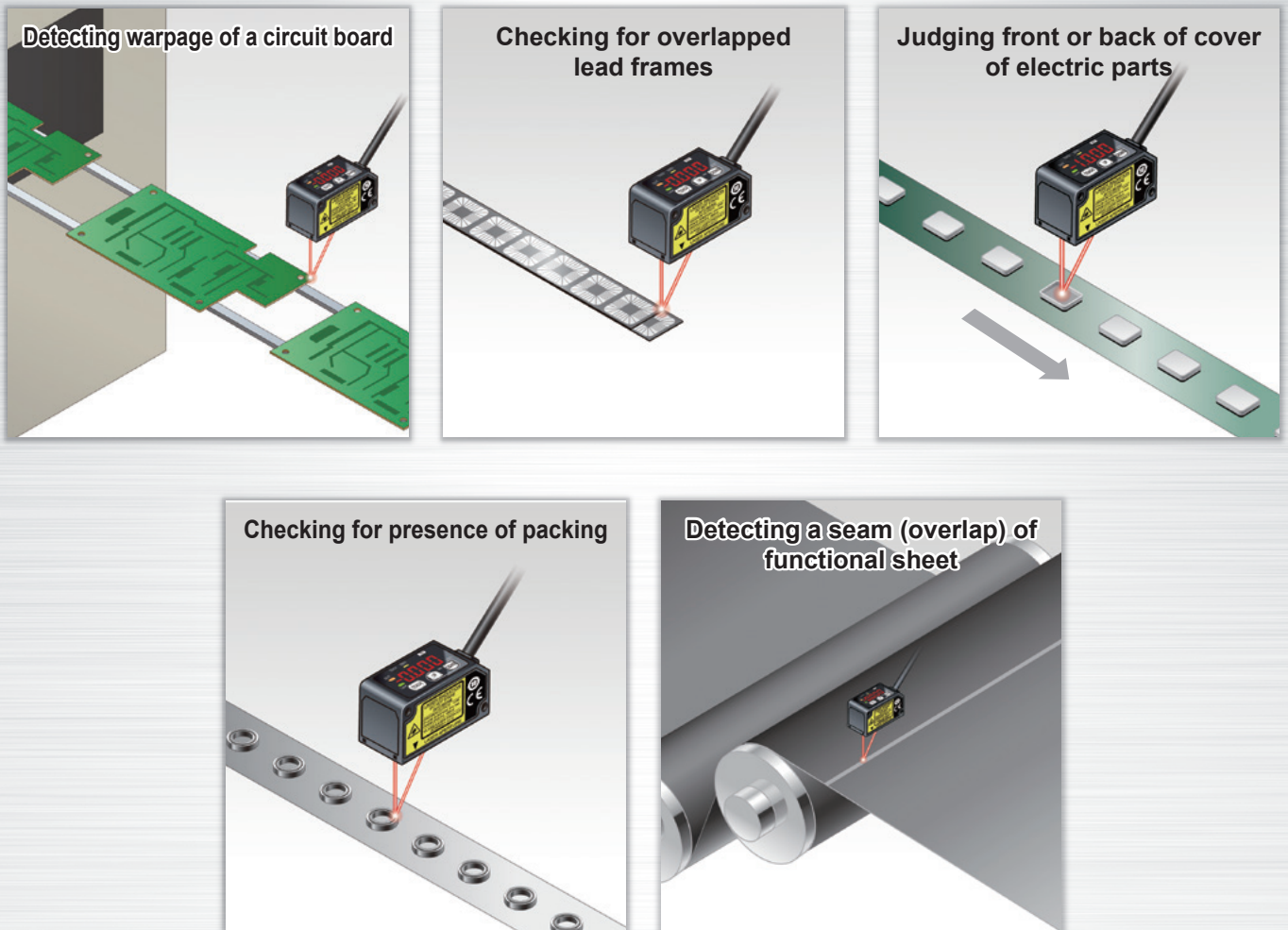

Fitted with a precise CMOS image sensor and an original algorithm

Thanks to a precise CMOS image sensor, it is now possible to perform highly precise measurements in the order of 1/100 mm **0.0003 in**. The existing adjustable range reflective sensors cannot achieve such accuracy.

Example: HG-C1030(-P)

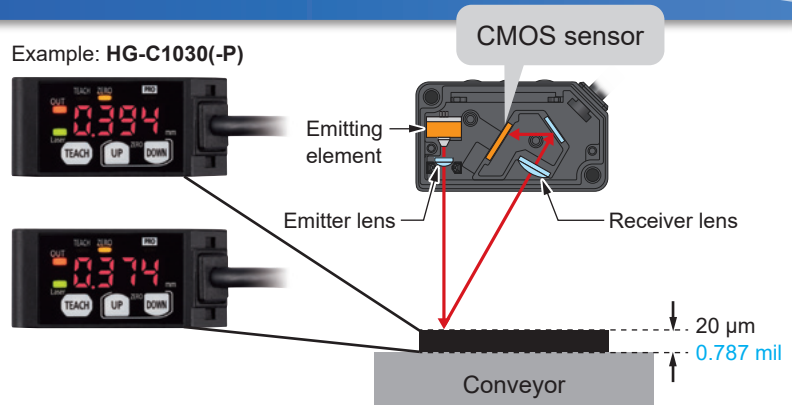

HG-C SERIES

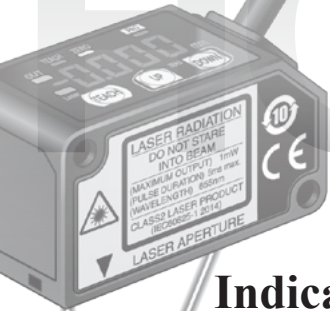

Indicates real measurements

Linearity: $\pm 0.1\%$ F.S.
 *HG-C1030(-P) / HG-C1050(-P) / HG-C1100(-P)

Compact and

W20 × H44 × D25 mm W0
 35 g approx. (excluding

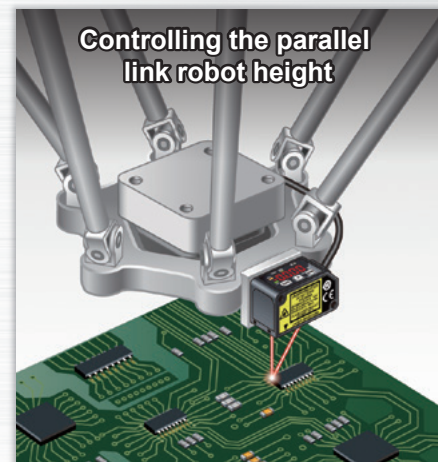
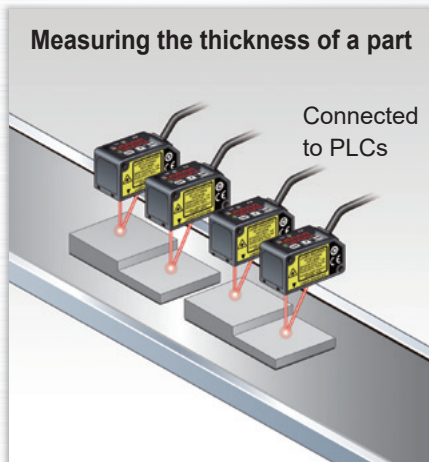
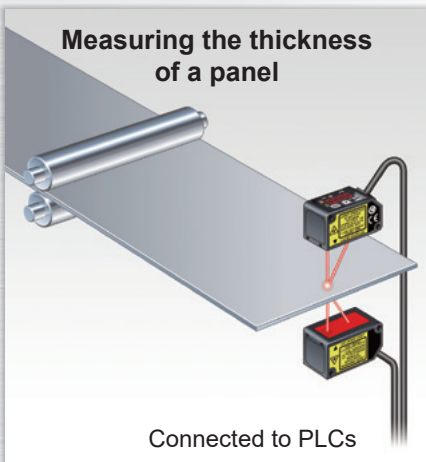
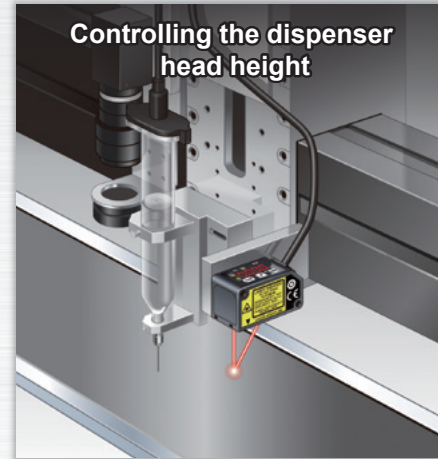
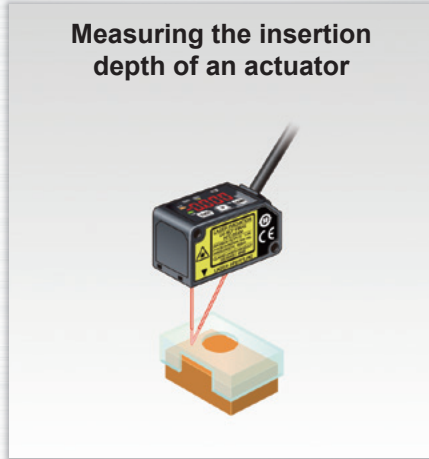
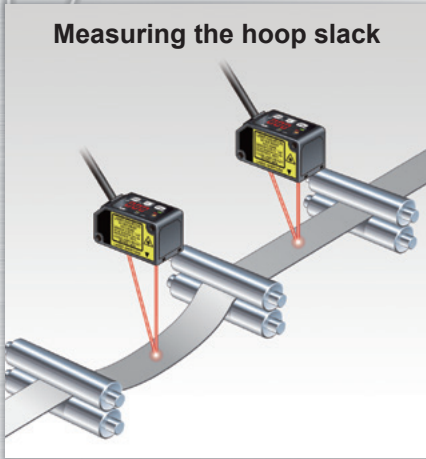

* If there is no workpiece between the sensors, avoid interference light by stopping the light emitting.

Equipped with 0 to 5 V analog output and 4 to 20 mA analog current output
 Excluding HG-C1000L series

The value can be measured with a distance measurement sensor.

- Linearity: $\pm 0.1\%$ F.S.*
- Temperature characteristics: 0.03%F.S./°C

The sensor not only indicates measured values in mm but also produces analog outputs. Various calculations and storage (logging) can be performed when output is taken into a PLC + analog unit.

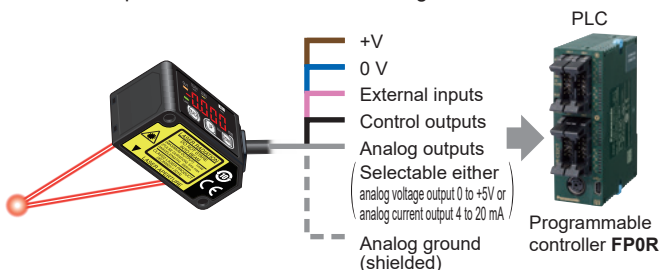

*HG-C1030(-P)/ HG-C1050(-P)/ HG-C1100(-P)

Linearity characteristics [Typical example: HG-C1030(-P)]

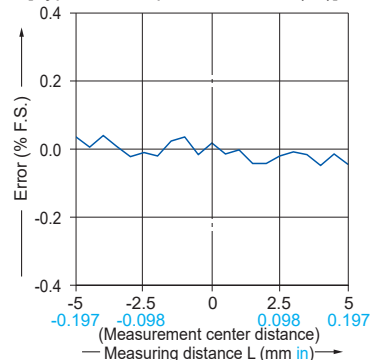

Compact

The smallest CMOS laser sensor in the industry*

*Based on research conducted by our company as of July 2022

light-weight

11.787 × 11.732 × D0.984 in,
the cable) *HG-C1□0(-P)

Long distance measurement

Measurement center distance: 400 mm 15.748 in *HG-C1400□,
200 mm 7.874 in *HG-C1200□

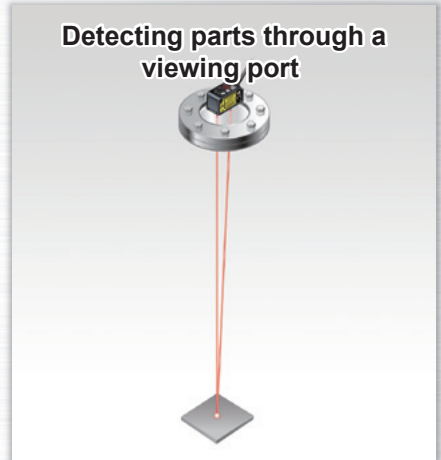
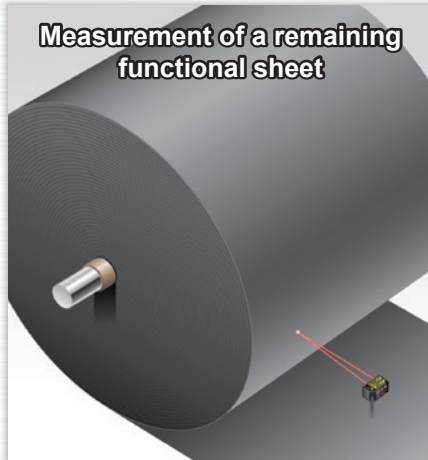
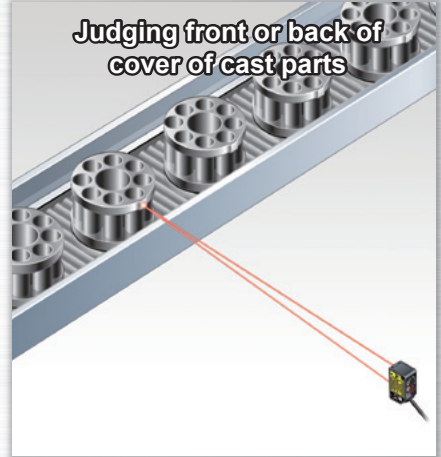

* Remove water droplets on detection surface to achieve correct measurement.

A new optical system with a built-in mirror

In general, more accurate and stable measurements can be obtained by increasing the optical path length between the light-receiving part and the light receiving element (CMOS), but this also increases the sensor depth and the sensor body gets bigger.

The **HG-C** series sensors incorporating a new optical system with a built-in mirror provides smaller sensor depth as well as higher measurement accuracy equivalent to displacement sensors.

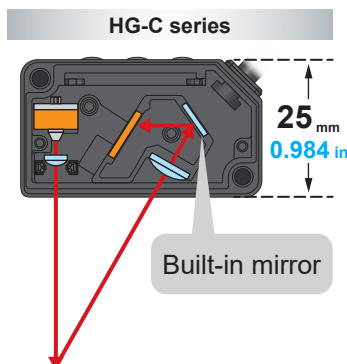

An aluminum die-cast casing protects from strain and heat

A light-weight but strong die-cast aluminum casing has been adopted. A compact, solid body casing reduces the impact of strain and heat on the measurement accuracy.

Aluminum die-cast casing



Useful functions

Teaching & window comparator mode

Normal sensing mode

2-Point teaching Basic teaching method

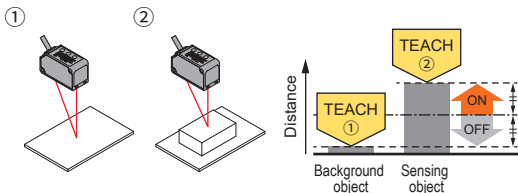

The threshold value is set automatically at the midpoint between the two points specified by teaching.

Limit teaching

Useful teaching method for when there is a very small object or background object.

< When using background object as reference >

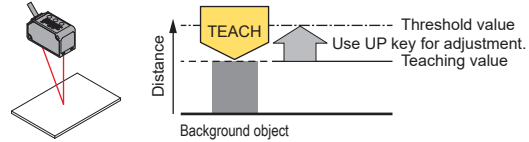

When the sensing object is located closer to the sensor than the background object, the threshold value for detection is set. This function is useful when there is a change in the size of sensing object.

< When using sensing object as reference >

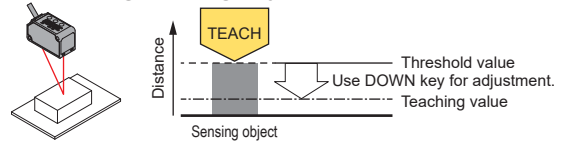

The threshold value is set on the background object side with reference to the sensing object. Use this method when there is a long distance to the background object.

Window comparator mode

With an object below the sensor, press the TEACH key to set the valid range for distances via threshold values. There are 3 methods for setting the valid range: 1-point, 2-point, and 3-point teaching.

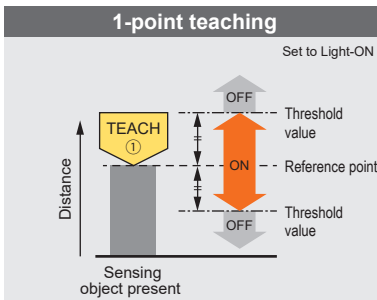

Perform 1-point teaching and the threshold range is set for the distance from the reference surface of the sensing object. This is used for sensing within the threshold range.

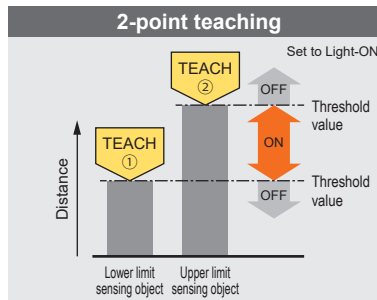

Press TEACH once for the lower (first point) and once for the upper limit (second point).

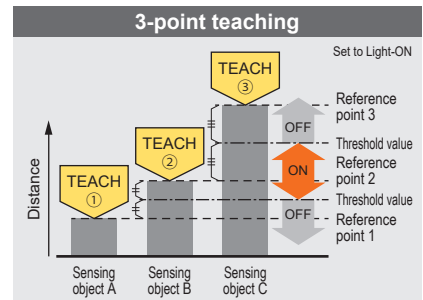

This is the method to set the threshold range by conducting the teaching at 3 points (sensing object A, B and C). After teaching, the reference points are automatically sorted in ascending order (reference point 1, 2 and 3). The thresholds are set at the midpoints between reference point 1 and 2, and 2 and 3, respectively.

Rising differential mode / Trailing differential mode

Use this mode to cancel gradual changes in the measured value and to detect only sudden changes. For the setting of threshold value, use the threshold value fine adjustment function.

Timer setting function

The time mode options are "off-delay timer," "on-delay timer," "one-shot timer" and "no timer." The counting time is fixed to 5 ms.*

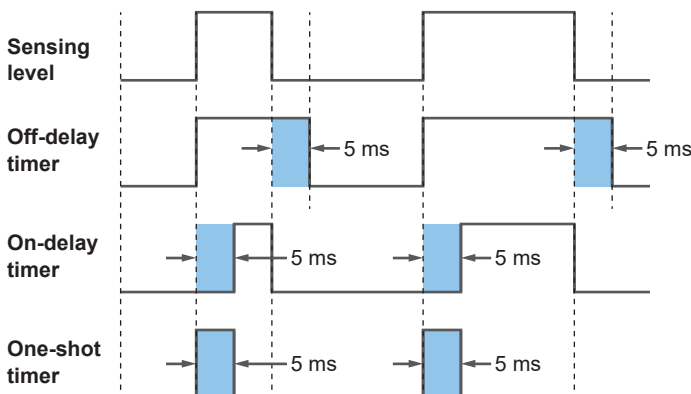

Timer period: 5 ms (fixed)*

* In the case of HG-C100L series, the timer time can be changed. (See page 16)

Off-delay timer

Function: Extends output signals by 5 ms.
Usage: Appropriate in case a connected device is slow to respond and ON time is required to extend.

On-delay timer

Function: Overrides output signals for 5 ms after detection.
Usage: Convenient way to override temporary signals and control with a time lag.

One-shot timer

Function: Sends output signals for only 5 ms after detection.
Usage: Useful when the signal duration needs to be constant to meet inputs from a connected device. This mode is also used to extend temporary signals by a desired length of time.

Zero set function

This function compulsorily sets the measured value to "zero." The zero point can be set at a desired value. It is useful when measuring steps or tolerance with reference to the height of a sensing object.

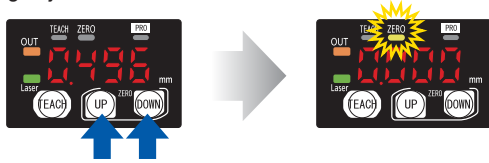

Keep pressing both keys for 3 seconds.

- * The zero set indicator (yellow) will turn ON while the zero set is valid.
- * When the zero set function is executed while the peak hold function or the bottom hold function is valid, the held measurement value is reset.
- * When the display setting is set to offset, the zero set function cannot be set.

External input setting function

Excluding HG-C1000L series

One of four functions, "zero setting function," "teaching function," "emission stopping function" and "trigger function" can be assigned to an external input line.

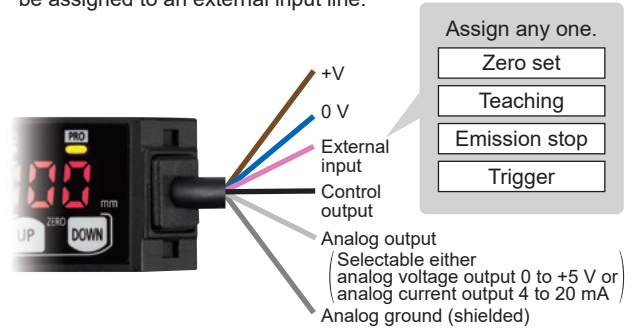

Display setting function

How to indicate measured values of the moving sensed object can be chosen from three options, "Normal," "Invert" and "Offset."

Example: HG-C1050(-P)

		Outside the measuring range	Measuring near point	Measurement center	Measuring far point	Outside the measuring range
Display setting	Normal	---	1500 mm	000 mm	-1500 mm	---
	Invert	---	-1500 mm	000 mm	1500 mm	---
	Offset	---	3000 mm	1500 mm	000 mm	---

■ Relation between the setting display and the analog output (in case of analog voltage) output

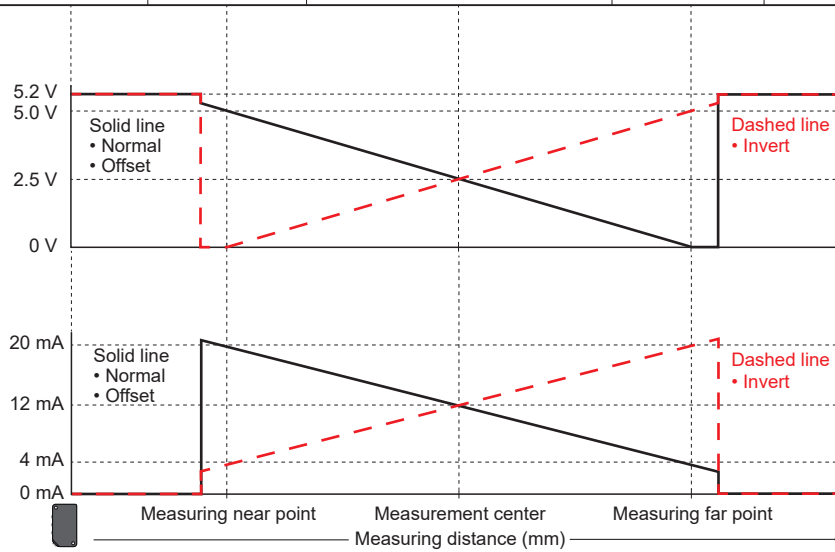

(in case of analog current) output

Peak and bottom hold functions

The peak hold function holds the maximum measured value which is output and displayed.

The bottom hold function holds the minimum measured value which is output and displayed.

- * The peak hold function and the bottom hold function cannot be set at the same time.
- * When the zero set function is executed while the peak hold function or the bottom hold function is valid, the held measurement value is reset.

Threshold value fine adjustment function

Fine adjustment of threshold values can be performed while measurement is proceeding on the display, and even after teaching.

- * For other functions and procedures for setting the functions, see the instruction manual of the product.

Key lock function

This function protects setting conditions from unintentional changes.

Reduction of the data analysis burden - one small step towards IoT.

IO-Link Compatible, Self-monitoring type **HG-C1000L SERIES** **Self-Monitoring Sensor**

IO-Link compatible

Collecting sensor level data

Field data collected and accumulated for “preventive maintenance” and “operation monitoring”.

An analysis of such field data requires high-level know-how and time, causing a burden to people responsible for the production site management.

The **Self-Monitoring Sensor** manufactured by Panasonic Industry is capable of reporting sensor data and its own state to the host device through the I/O Link master.

With the Self-Monitoring Sensor, you can immediately judge the state of the sensor and easily identify the cause of failure. Thus, this sensor contributes to the **reduction of the burden experienced by the client in collecting and analyzing data.**

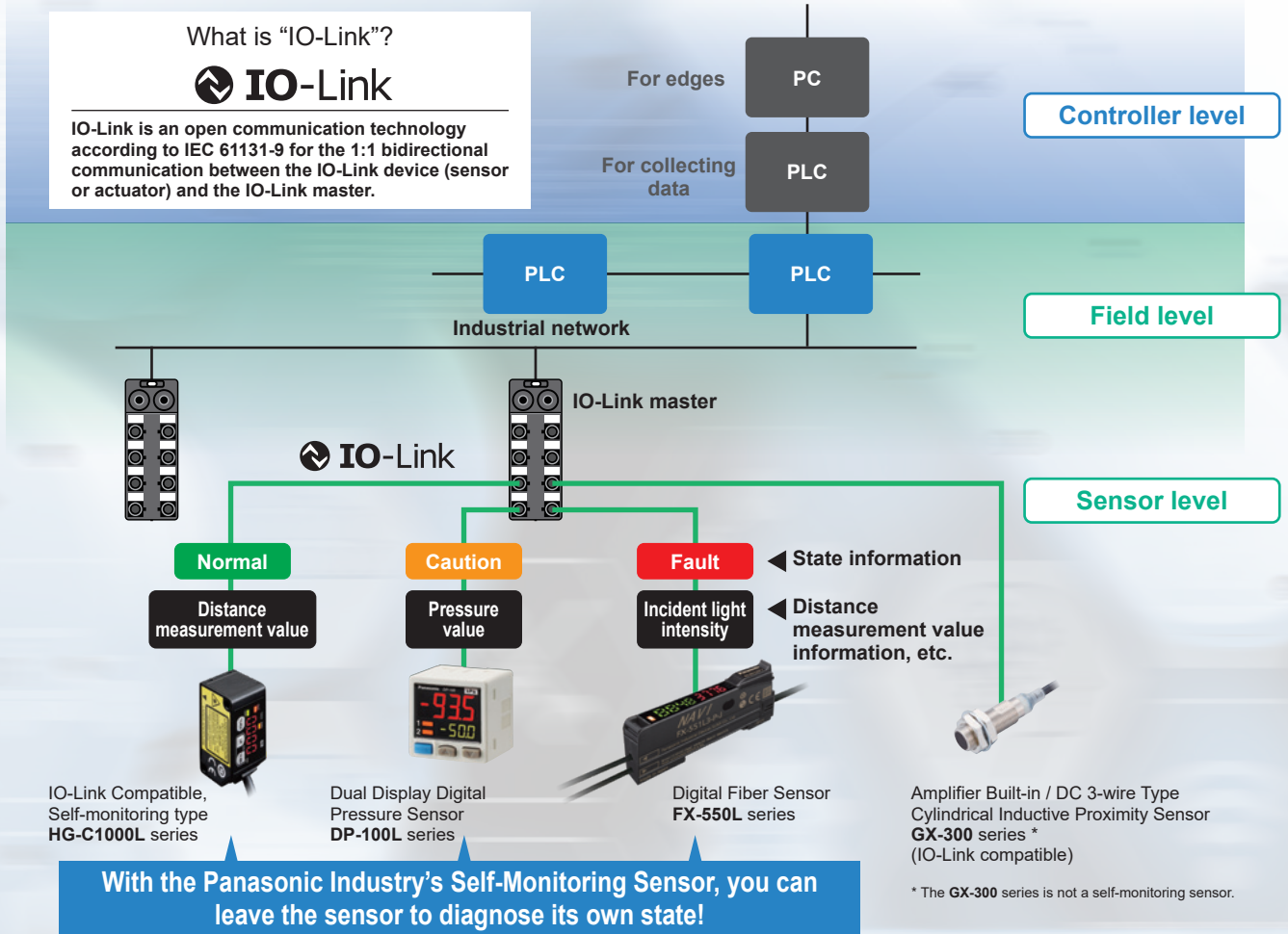

Before the introduction of Self-Monitoring Sensors

- We want to avoid production line stoppage that might occur due to unexpected sensor failure.
- Line stoppage hours × (manufacturing unit cost / hour) = Loss**
- We want to minimize the production line down time to almost zero.

Issues unveiled by predictive maintenance

- The amount of data to be collected is large and this may lower the PLC processing capacity.
- The burden of data analysis is large.
- Resetting the replaced sensors is troublesome.

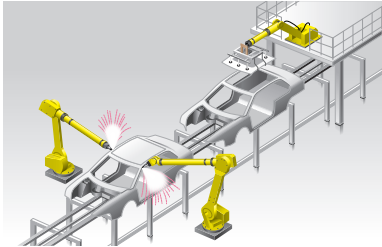

After the introduction of Self-Monitoring Sensors

- The Self-Monitoring Sensor helps solve existing issues and enables easier improvement of equipment operating rates.

Predictive maintenance creates efficient, worker-friendly environments.

Leave the sensor diagnosis to the sensor itself.

- All you need to do is to monitor the sensor state.
- PLC can be used exclusively for controlling devices.
- Possible to check detail information at a desired timing.

Leave the resetting for replaced sensors to the higher-level master

- Automatically written from the connected master.
- Possible not only to save time but also to prevent human errors.

Incorporated self-monitoring function

With the Panasonic Industry's Self-Monitoring Sensor, you can get high-level solutions!

The introduction of IoT requires collection of the distance measurement value data and presents the following problems.

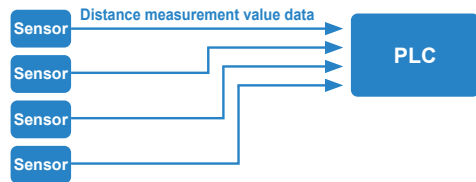

Previously only ON/OFF data was required. But, due to an addition of the distance measurement value data, the PLC processing burden has increased.

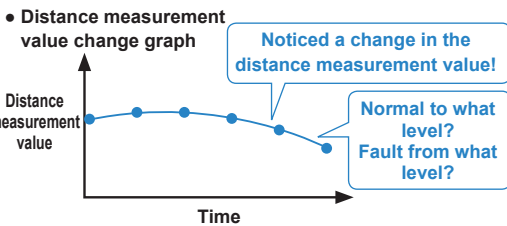

We noticed a change in the distance measurement value. However, because there is no judgment criteria, we cannot tell whether the incident light status is normal or not.

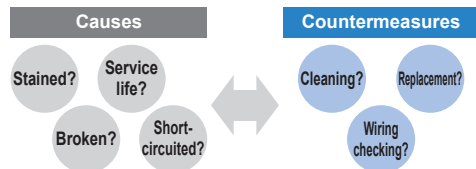

Unless we identify the cause of changes in the distance measurement value, we cannot optimize countermeasures targeting the sensors.

Problems are solved by the Self-monitoring function.

Self-monitoring function

A sensor with a self-monitoring function diagnoses its own state and notifies when readjustment of settings / setup is required or when maintenance is needed. The sensor determines its status and indicates "Normal," "Notification," "Caution" or "Fault." When not in normal status, the sensor checks the cause of problem and corrective measure, thus reducing equipment downtime and maintenance workload.

Self-monitoring function: Four types of status indication and judgment of state

Status	Judgement of the state	
Normal	Operation is normal.	
Notification	Check the settings. Detected state is faulty.	* Recover to the normal state through checking installation and settings. Reduction in the incident light intensity.
Caution	Getting close to the end of service life. Reached the state where the device should be replaced.	* Limitation in the writing frequency into the memory or in the operation hours, etc.
Fault	Short-circuited or broken. Reached the state where it is impossible to control as a device.	* Short-circuited output, damaged EEPROM, etc.

* By creating a program with a PLC, etc., the "State" of the self-monitoring sensor can be grasped.

Easy use of IoT

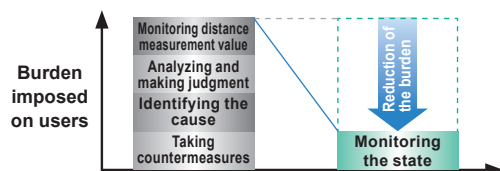

"Predictive maintenance" can be easily achieved through monitoring the state of the Self-Monitoring Sensor.

ORDER GUIDE

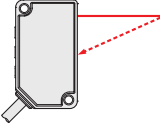
Type	Appearance	Measurement center distance and measurement range	Repeatability	Beam diameter (Note)	Model No.	
					NPN output	PNP output
Measurement center 30 mm 1.181 in type		30 ± 5 mm 1.181 ± 0.197 in	10 µm 0.394 mil	ø50 µm 1.969 mil approx.	HG-C1030	HG-C1030-P
Measurement center 50 mm 1.969 in type		50 ± 15 mm 1.969 ± 0.591 in	30 µm 1.181 mil	ø70 µm 2.756 mil approx.	HG-C1050	HG-C1050-P
Measurement center 100 mm 3.937 in type		100 ± 35 mm 3.937 ± 1.328 in	70 µm 2.756 mil	ø120 µm 4.724 mil approx.	HG-C1100	HG-C1100-P
Measurement center 200 mm 7.874 in type		200 ± 80 mm 7.874 ± 3.150 in	200 µm 7.874 mil	ø300 µm 11.811 mil approx.	HG-C1200	HG-C1200-P
Measurement center 400 mm 15.748 in type		400 ± 200 mm 15.748 ± 7.874 in	300 µm 11.811 mil (Measuring distance 200 to 400 mm 7.874 to 15.748 in) 800 µm 31.496 mil (Measuring distance 400 to 600 mm 15.748 to 23.622 in)	ø500 µm 19.685 mil approx.	HG-C1400	HG-C1400-P

Note: This is the size in the measurement center distance. These values were defined by using $1/e^2$ (13.5 % approx.) of the center light intensity. Due to leak light outside the specified area, the reflectance around the detecting point may be higher than at the point and this may affect the measurement value.

IO-Link compatible, Self-monitoring type HG-C1000L series

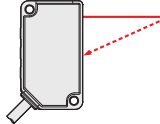
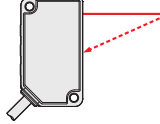
Type	Appearance	Measurement center distance and measurement range	Repeatability	Beam diameter (Note)	Model No.	Control output
Discrete wire type		Measurement center 30 mm 1.181 in type 30 ± 5 mm 1.181 ± 0.197 in	10 µm 0.394 mil	ø50 µm 1.969 mil approx.	HG-C1030L3-P	PNP open-collector transistor
		Measurement center 50 mm 1.969 in type 50 ± 15 mm 1.969 ± 0.591 in	30 µm 1.181 mil	ø70 µm 2.756 mil approx.	HG-C1050L3-P	
		Measurement center 100 mm 3.937 in type 100 ± 35 mm 3.937 ± 1.328 in	70 µm 2.756 mil	ø120 µm 4.724 mil approx.	HG-C1100L3-P	
		Measurement center 200 mm 7.874 in type 200 ± 80 mm 7.874 ± 3.150 in	200 µm 7.874 mil	ø300 µm 11.811 mil approx.	HG-C1200L3-P	
		Measurement center 400 mm 15.748 in type 400 ± 200 mm 15.748 ± 7.874 in	300 µm 11.811 mil (Measuring distance 200 to 400 mm 7.874 to 15.748 in) 800 µm 31.496 mil (Measuring distance 400 to 600 mm 15.748 to 23.622 in)	ø500 µm 19.685 mil approx.	HG-C1400L3-P	
M12 connector type		Measurement center 30 mm 1.181 in type 30 ± 5 mm 1.181 ± 0.197 in	10 µm 0.394 mil	ø50 µm 1.969 mil approx.	HG-C1030L3-P-J	
		Measurement center 50 mm 1.969 in type 50 ± 15 mm 1.969 ± 0.591 in	30 µm 1.181 mil	ø70 µm 2.756 mil approx.	HG-C1050L3-P-J	
		Measurement center 100 mm 3.937 in type 100 ± 35 mm 3.937 ± 1.328 in	70 µm 2.756 mil	ø120 µm 4.724 mil approx.	HG-C1100L3-P-J	
		Measurement center 200 mm 7.874 in type 200 ± 80 mm 7.874 ± 3.150 in	200 µm 7.874 mil	ø300 µm 11.811 mil approx.	HG-C1200L3-P-J	
		Measurement center 400 mm 15.748 in type 400 ± 200 mm 15.748 ± 7.874 in	300 µm 11.811 mil (Measuring distance 200 to 400 mm 7.874 to 15.748 in) 800 µm 31.496 mil (Measuring distance 400 to 600 mm 15.748 to 23.622 in)	ø500 µm 19.685 mil approx.	HG-C1400L3-P-J	

Notes: This is the size in the measurement center distance. These values were defined by using $1/e^2$ (13.5 % approx.) of the center light intensity. Due to leak light outside the specified area, the reflectance around the detecting point may be higher than at the point and this may affect the measurement value.

OPTIONS

Designation	Model No.	Description
Simple mounting bracket (Note)	MS-HG-01	Foot angled mounting bracket

Note: Due to the simple mounting bracket, the sensing characteristics may not be hold depending on the installation condition, in case of the purposes for acquiring the displacement data and a fine detecting.

Recommended extension cables for M12 connector type

Manufactured by OMRON Corporation
Extension cable with connectors on both ends XS5W series

* Please contact the manufacturer for details of the recommended products.

Simple mounting bracket

•MS-HG-01

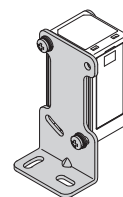

Material: Stainless steel (SUS304)

Two M3 (length 25 mm 0.984 in) screws with washers (SPCC) are attached.

SPECIFICATIONS

Item	Model No.	Type	Measurement center 30 mm 1.181 in type	Measurement center 50 mm 1.969 in type	Measurement center 100 mm 3.937 in type	Measurement center 200 mm 7.874 in type	Measurement center 400 mm 15.748 in type	
		NPN output	HG-C1030	HG-C1050	HG-C1100	HG-C1200	HG-C1400	
		PNP output	HG-C1030-P	HG-C1050-P	HG-C1100-P	HG-C1200-P	HG-C1400-P	
Applicable regulations and certifications			CE Marking (EMC Directive, RoHS Directive), UKCA Marking (EMC Regulations, RoHS Regulations), FDA Regulations, UL/c-UL Recognition					
Measurement center distance			30 mm 1.181 in	50 mm 1.969 in	100 mm 3.937 in	200 mm 7.874 in	400 mm 15.748 in	
Measurement range			±5 mm 0.197 in	±15 mm 0.591 in	±35 mm 1.328 in	±80 mm 3.150 in	±200 mm 7.874 in	
Repeatability			10 μm 0.394 mil	30 μm 1.181 mil	70 μm 2.756 mil	200 μm 7.874 mil	300 μm 11.811 mil (Measuring distance 200 to 400 mm 7.874 to 15.748 in) 800 μm 31.496 mil (Measuring distance 400 to 600 mm 15.748 to 23.622 in)	
Linearity			±0.1 % F.S.			±0.2 % F.S.		±0.2 % F.S. (Measuring distance 200 to 400 mm 7.874 to 15.748 in) ±0.3 % F.S. (Measuring distance 400 to 600 mm 15.748 to 23.622 in)
Temperature characteristic			0.03 % F.S./°C					
Light source			Red semiconductor laser Class 2 [IEC/EN/JIS/GB/KS/FDA (Note 2)] Max. output: 1 mW, emission peak wavelength: 655 nm 0.026 mil					
Beam diameter (Note 3)			ø50 μm 1.969 mil approx.	ø70 μm 2.756 mil approx.	ø120 μm 4.724 mil approx.	ø300 μm 11.811 mil approx.	ø500 μm 19.685 mil approx.	
Supply voltage			12 to 24 V DC ±10 %, Ripple P-P 10 % or less					
Power consumption			40 mA or less (at 24 V DC supply voltage), 65 mA or less (at 12 V DC supply voltage)					
Control output			<NPN output type> NPN open-collector transistor • Maximum sink current: 50 mA • Applied voltage: 30 V DC or less (Between control output to 0V) • Residual voltage: 1.5 V or less (At 50 mA sink current) • Leakage current: 0.1 mA or less			<PNP output type> PNP open-collector transistor • Maximum source current: 50 mA • Applied voltage: 30 V DC or less (Between control output to +V) • Residual voltage: 1.5 V or less (At 50 mA source current) • Leakage current: 0.1 mA or less		
Output operation			Switchable between either Light-ON or Dark-ON					
Short-circuit protection			Incorporated (Auto reset type)					
Analog output			Analog voltage output • Output range: 0 to +5 V (at alarm: +5.2 V) • Output impedance: 100 Ω			Analog current output • Output range: 4 to 20 mA (at alarm: 0 mA) • Load impedance: 300 Ω or less		
Response time			Switchable between 1.5 ms / 5 ms / 10 ms					
External input			<NPN output type> NPN non-contact input • Input conditions Invalid: +8 to +V DC or Open Valid: 0 to +1.2 V DC • Input impedance: 10 kΩ approx.			<PNP output type> PNP non-contact input • Input conditions Invalid: 0 to +0.6 V DC or Open Valid: +4 to +V DC • Input impedance: 10 kΩ approx.		
Pollution degree			2					
Operating altitude			2,000 m 6561.680 ft or less					
Environmental resistance	Protection		IP67 (IEC)					
	Ambient temperature		-10 to +45 °C -14 to 113 °F (No dew condensation or icing allowed), Storage: -20 to +60 °C -4 to 140 °F					
	Ambient humidity		35 to 85 % RH, Storage: 35 to 85 % RH					
	Ambient illuminance		Incandescent light: 3,000 lx or less at the light-receiving face					
	Vibration resistance		10 to 55 Hz (period: 1 min.) frequency, 1.5 mm 0.059 in double amplitude in X, Y and Z directions for two hours each					
	Shock resistance		500 m/s ² acceleration (50 G approx.) in X, Y and Z directions three times each					
Cable			5-core composite cable, 2 m 6.5617 ft long					
Cable extension			Extension up to total 10 m 32.808 ft is possible with 0.3 mm ² , or more, cable.					
Material			Enclosure: Aluminum die-cast, Front cover: Acrylic					
Weight			Net weight: 35 g approx. (without cable), 85 g approx. (including cable)					

- Notes: 1) Supply voltage: 24 V DC, ambient temperature: +20 °C **+68 °F**, response time: 10 ms, and analog output value of measurement center distance are used for unspecified measurement conditions. The subject is white ceramics.
2) This product complies with the FDA regulations (FDA 21 CFR 1040.10 and 1040.11) in accordance with FDA Laser Notice No. 56, except for complying with IEC 60825-1 Ed. 3.
3) This is the size in the measurement center distance. These values were defined by using 1/e² (13.5 % approx.) of the center light intensity. Due to leak light outside the specified area, the reflectance around the detecting point may be higher than at the point and this may affect the measurement value.

SPECIFICATIONS

IO-Link compatible, Self-monitoring type HG-C1000L series

Item	Model No.	Type	Measurement center 30 mm 1.181 in type	Measurement center 50 mm 1.969 in type	Measurement center 100 mm 3.937 in type	Measurement center 200 mm 7.874 in type	Measurement center 400 mm 15.748 in type
		Discrete wire	HG-C1030L3-P	HG-C1050L3-P	HG-C1100L3-P	HG-C1200L3-P	HG-C1400L3-P
		M12 connector	HG-C1030L3-P-J	HG-C1050L3-P-J	HG-C1100L3-P-J	HG-C1200L3-P-J	HG-C1400L3-P-J
Applicable regulations and certifications		CE Marking (EMC Directive, RoHS Directive), UKCA Marking (EMC Regulations, RoHS Regulations), FDA Regulations, UL/c-UL Recognition					
Measurement center distance		30 mm 1.181 in	50 mm 1.969 in	100 mm 3.937 in	200 mm 7.874 in	400 mm 15.748 in	
Measurement range		±5 mm 0.197 in	±15 mm 0.591 in	±35 mm 1.328 in	±80 mm 3.150 in	±200 mm 7.874 in	
Repeatability		10 μm 0.394 mil	30 μm 1.181 mil	70 μm 2.756 mil	200 μm 7.874 mil	300 μm 11.811 mil (Measuring distance 200 to 400 mm 7.874 to 15.748 in) 800 μm 31.496 mil (Measuring distance 400 to 600 mm 15.748 to 23.622 in)	
Linearity		±0.1 % F.S.			±0.2 % F.S.		±0.2 % F.S. (Measuring distance 200 to 400 mm 7.874 to 15.748 in) ±0.3 % F.S. (Measuring distance 400 to 600 mm 15.748 to 23.622 in)
Temperature characteristic		0.03 % F.S./°C					
Light source		Red semiconductor laser Class 2 [IEC/EN/JIS/GB/KS/FDA (Note 2)] Max. output: 1 mW, emission peak wavelength: 655 nm 0.026 mil					
Beam diameter (Note 3)		ø50 μm 1.969 mil approx	ø70 μm 2.756 mil approx.	ø120 μm 4.724 mil approx.	ø300 μm 11.811 mil approx.	ø500 μm 19.685 mil approx.	
Supply voltage		24 V DC ±10 % Ripple P-P 10 %					
Power consumption		40 mA or less (at 24 V DC supply voltage)					
Communication output (C/Q) (Note 4)		IO-Link communication	IO-Link Specification V1.1				
		Baud rate	COM3 (230.4 kbps)				
		Process data	4 byte				
		Minimum cycle time	1.0 ms				
Control output (DO)		PNP open-collector transistor • Maximum source current: 50 mA • Applied voltage: 30 V DC or less (Between control output to +V) • Residual voltage: 1.5 V or less (at 50 mA source current) • Leakage current: 0.1 mA or less					
		Output operation	Switchable between either Light-ON or Dark-ON				
		Short-circuit protection	Incorporated (auto reset type)				
Response time		Switchable between 1.5 ms / 5 ms / 10 ms					
Pollution degree		2					
Ambient altitude		2,000 m 6561.680 ft or less					
Environmental resistance		Protection	IP67 (IEC)				
		Ambient temperature	-10 to +45 °C -14 to 113 °F (No dew condensation or icing allowed), Storage: -20 to +60 °C -4 to 140 °F				
		Ambient humidity	35 to 85 % RH, Storage: 35 to 85 % RH				
		Ambient illuminance	Incandescent light: 3,000 lx or less at the light-receiving face				
		Vibration resistance	10 to 55 Hz (period: 1 min.) frequency, 1.5 mm 0.059 in double amplitude in X, Y and Z directions for two hours each				
		Shock resistance	500 m/s ² acceleration (50 G approx.) in X, Y and Z directions three times each				
Cable		Discrete wire type: 0.2 mm ² 4-core PVC cable, 2 m 6.562 ft long M12 connector type: 0.2 mm ² 4-core PVC cable with connector, 0.3 m 0.984 ft long					
Cable extension		Extension up to total 20 m 65.617 ft is possible with 0.3 mm ² , or more, cable.					
Material		Enclosure: Aluminum die-cast, Front cover: Acrylic					
Weight		Discrete wire type: 30 g approx. (without cable), 80 g approx. (including cable) M12 connector type: 30 g approx. (without cable), 50 g approx. (including cable)					

- Notes: 1) Supply voltage: 24 V DC, ambient temperature: +20 °C **+68 °F**, response time: 10 ms, and analog output value of measurement center distance are used for unspecified measurement conditions. The subject is white ceramics.
2) This product complies with the FDA regulations (FDA 21 CFR 1040.10 and 1040.11) in accordance with FDA Laser Notice No. 56, except for complying with IEC 60825-1 Ed. 3.
3) This is the size in the measurement center distance. These values were defined by using 1/e² (13.5 % approx.) of the center light intensity. Due to leak light outside the specified area, the reflectance around the detecting point may be higher than at the point and this may affect the measurement value.
4) When the sensor is used as an ordinary sensor, the communication output (C/Q) provides the same output operation as the control output (DO).

I/O CIRCUIT AND WIRING DIAGRAMS

HG-C1□0

NPN output type

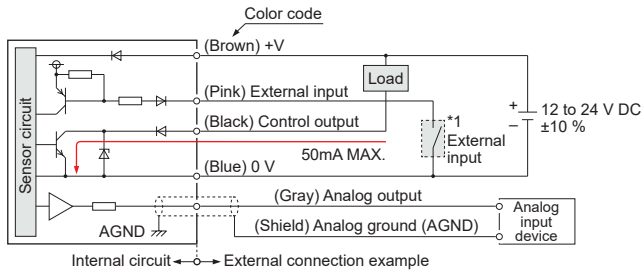

*1

Non-voltage contact or NPN open-collector transistor

- External input
- Invalid: +8 V to +V DC or open
- Valid: 0 to +1.2 V DC

HG-C1□0-P

PNP output type

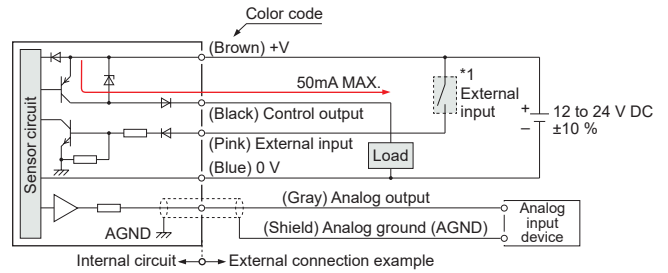

*1

Non-voltage contact or PNP open-collector transistor

- External input
- Invalid: 0 to +0.6 V DC or open
- Valid: +4 V to +V DC

HG-C□L3-P

IO-Link compatible, Self-monitoring, Discrete wire type

<When using as an ordinary sensor>

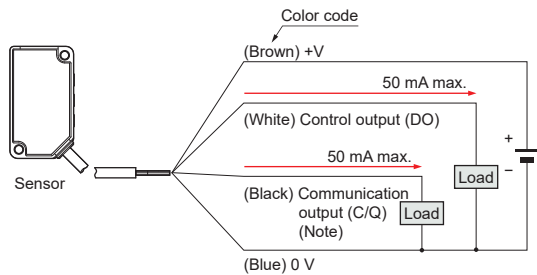

<When connecting to the IO-Link master>

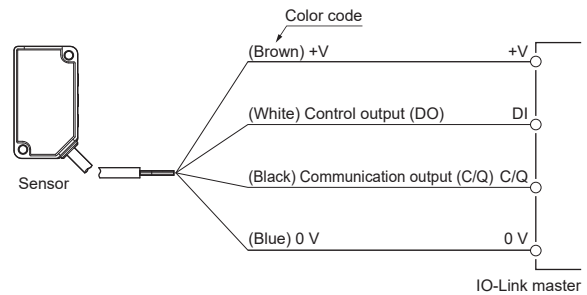

Note: When the sensor is used as an ordinary sensor, the communication output (C/Q) provides the same output operation as the control output (DO).

HG-C□L3-P-J

IO-Link compatible, Self-monitoring, M12 connector type

<When using as an ordinary sensor>

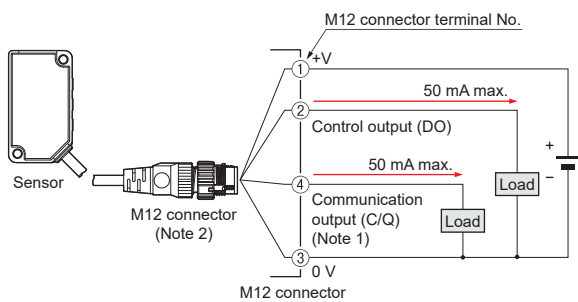

<When connecting to the IO-Link master>

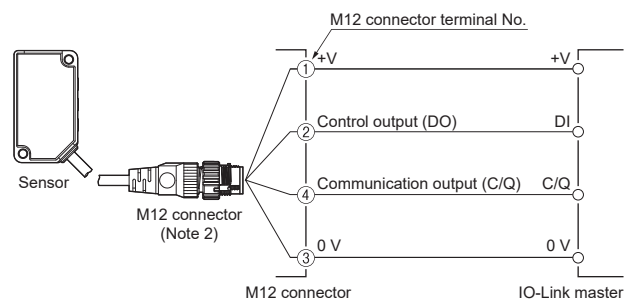

Notes: 1) When the sensor is used as an ordinary sensor, the communication output (C/Q) provides the same output operation as the control output (DO).
2) When wiring with the discrete wire or extending the cable from the M12 connector, separately prepare commercially available M12 connector cable.

M12 connector terminal arrangement diagram

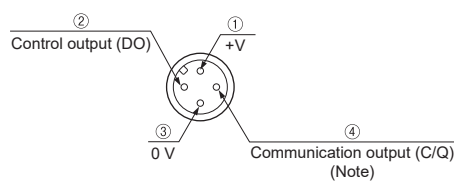

Terminal No.	Designation
①	+V
②	Control output (DO)
③	0 V
④	Communication output (C/Q) (Note)

Note: When the sensor is used as an ordinary sensor, the communication output (C/Q) provides the same output operation as the control output (DO).

SENSING CHARACTERISTICS (TYPICAL)

Linearity

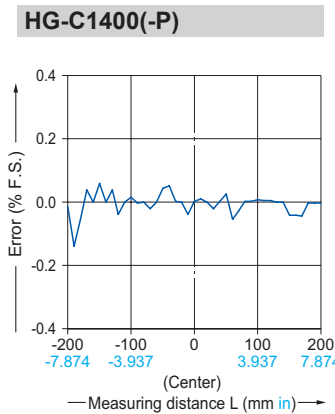
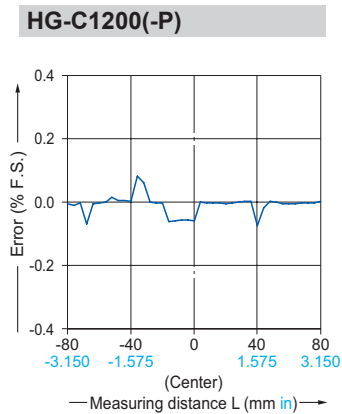
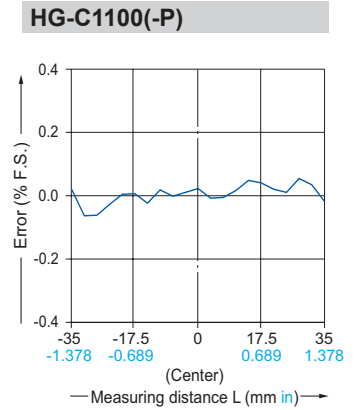
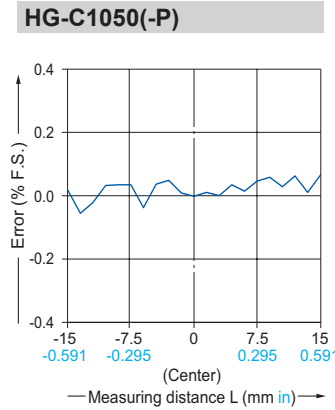
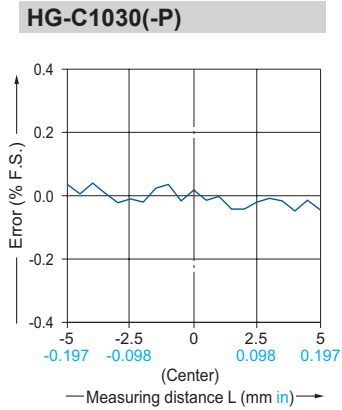
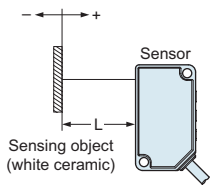

PRECAUTIONS FOR PROPER USE

Refer to the instruction manual for details. The instruction manual data can be downloaded from our website.

- This catalog is a guide to select a suitable product. Be sure to read instruction manual of the product prior to its use.



- Never use this product as a sensing device for personnel protection.
- In case of using sensing devices for personnel protection, use products which meet laws and standards, such as OSHA, ANSI or IEC etc., for personnel protection applicable in each region or country.



- Do not operate products using methods other than the ones described in the instruction manual of each product. Control or adjustment through procedures other than the ones specified may cause hazardous laser radiation exposure.



- This product is classified as a Class 2 Laser Product under IEC / EN / JIS / GB / KS standards and FDA * regulations. Do not look at the laser beam directly or through an optical system such as a lens.
- The warning label (English) is attached to the product. Handle the product according to the instruction given on the warning label. (The warning labels in Japanese, Korean and Chinese are packed with the sensor.)



*This product complies with the FDA regulations (FDA 21 CFR 1040.10 and 1040.11) in accordance with FDA Laser Notice No. 56, except for complying with IEC 60825-1 Ed. 3.

Part description

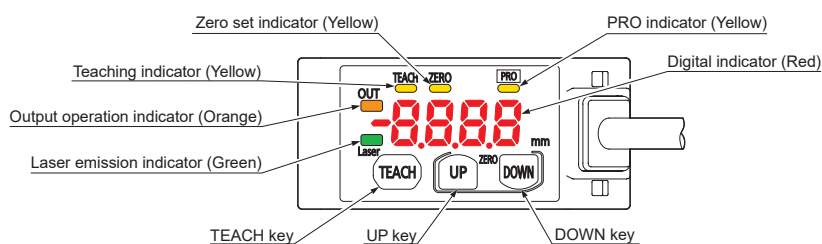

Mounting

- When mounting this product, use M3 screws. The tightening torque should be 0.5 N·m. Please prepare M3 screws separately.

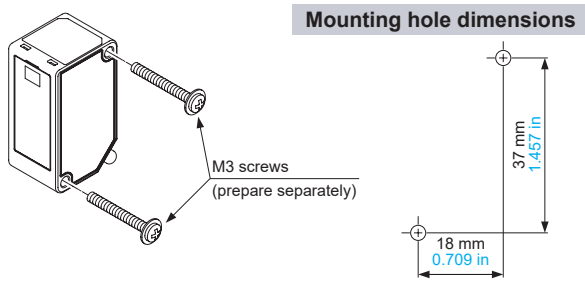

- When mounting the simple mounting bracket (optional) on this product, the tightening torque should be 0.5 N·m or less.

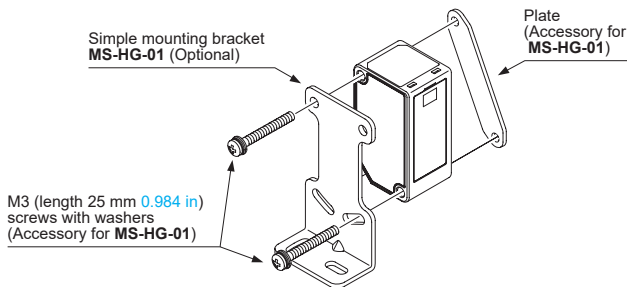

Note: Due to the simple mounting bracket, the sensing characteristics may not be hold depending on the installation condition, in case of the purposes for acquiring the displacement data and a fine detecting.

Mounting direction

Direction to a movable body

<When there are differences in material and color>

- When performing measurements of moving objects with excessively different materials and colors, mount the product per the following directions to minimize measurement errors.

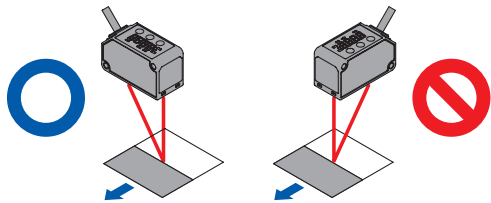

<Measurement of rotating objects>

- When measuring rotating objects, mount the product as follows. Measurement can be performed with minimized effect on the object caused by up / down deflection, position deviation and etc.

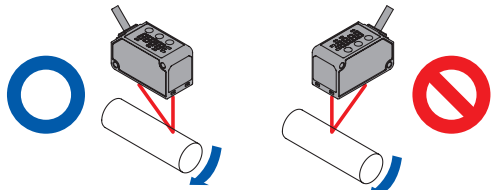

<When there is a step>

- When there is a step in the moving object, mount the product as follows. Measurement can be performed with minimized effect from the edges of the steps.

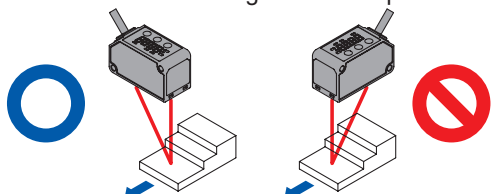

Measuring of narrow locations and recesses

- When measuring in narrow locations or inside holes, mount the product so that optical path from the light-emitting part to light-receiving part is not interrupted.

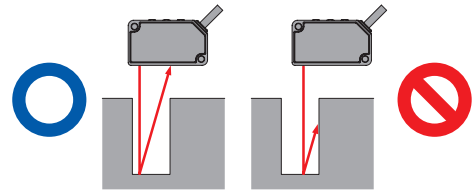

When mounting the product on a wall

- Mount the product as follows, so that the multiple light reflections on the wall do not emit to the light-receiving part. When the reflection factor on a wall is high, it is effective to use a dull black color.

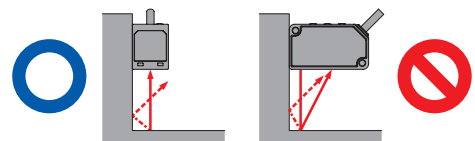

Others

- This product has been developed / produced for industrial use only.
- Make sure that the power supply is OFF before starting the wiring.
- If the wiring is performed incorrectly, it will cause a failure.
- Do not run the wires together with high-voltage lines or power lines, or put them in the same raceway. This can cause malfunction due to induction.
- Verify that the supply voltage variation is within the rating.
- If power is supplied from a commercial switching regulator, ensure that the frame ground (F.G.) terminal of the power supply is connected to an actual ground.
- If noise generating devices (switching regulators, inverter motors, etc.) are used around the sensor mounting area, make sure to connect the frame ground (FG) terminal of the device.
- Do not use this product during the transient state when the power supply is turned ON.
- The overall length of the cable can be extended to 10 m (32.808 ft maximum (HG-C1000L series: 20 m 65.617 ft maximum) with a cable size of 0.3 mm² or more.
- Make sure that stress by forcible bend or pulling is not applied to the sensor cable joint.
- Although it depends on the type, light from rapid start type or high frequency lighting type fluorescent lights, sunlight and etc. may affect the sensing, therefore make sure to prevent direct incident light.
- This product is suitable for indoor use only.
- Keep water, oil, fingerprints and etc. which reflect light, or dust, particles or etc. which interrupts the light, away from the emitting / receiving surfaces of this product. If contaminants adhere to the surface, wipe off with a dust-free soft cloth, or lens cleaning paper.
- Do not use the sensor in locations where there is excessive vapor, dust or etc. or in an atmosphere where corrosive gases, etc. is generated.
- Take care that the product does not come in contact with oil, grease, organic solvents such as thinner, etc., strong acid or alkaline.
- Make sure to turn OFF the power supply, before cleaning the light emitting / receiving windows of the sensor head.
- There is a certain deviation in the directionality of this product. Install the product using a mounting bracket or similar fitting to allow the adjustment of optical axis.
- The internal memory (nonvolatile) of this product has a service life. Settings cannot be configured more than 100,000 times.

PRO mode setting

Part description

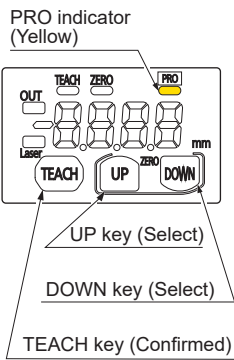

Item	Default setting	Description
Response time setting	Hr50	Set the response time. "Hr50": High precision 10 ms, "Std": Standard 5 ms, "FASh": High speed 1.5 ms
Output operation setting	L-on	Select the control output operation mode. "L-on": Light-ON, "d-on": Dark-ON
Sensing output setting	--S-	Set the sensing output. "NF": Normal sensing mode "A.1": 1-point teaching (Window comparator mode) "A.2": 2-point teaching (Window comparator mode) "A.3": 3-point teaching (Window comparator mode) "d.F": Rising differential mode "d.L": Trailing differential mode
Analog output setting [excluding HG-C1000L series]	volt	Set the output operation of analog output setting. "volt": Analog voltage output (0 to +5 V) "curr": Analog current output (4 to 20 mA)
Hysteresis setting	<HG-C1030□> 00 10 <HG-C1050□> 003 <HG-C1100□> 007 <HG-C1200□> 02 <HG-C1400□> 08	Set the hysteresis width. HG-C1030□: 0.001 to 5.00 mm 0.00004 to 0.197 in HG-C1050□: 0.01 to 15.00 mm 0.00039 to 0.591 in HG-C1100□: 0.02 to 35.00 mm 0.00079 to 1.378 in HG-C1200□: 0.1 to 80.0 mm 0.00394 to 3.150 in HG-C1400□: 0.2 to 200.0 mm 0.00787 to 7.874 in
External input setting [excluding HG-C1000L series]	0Set	Set the external input. "0Set": Zero set function, "tEcH": Teaching function "L-of": Light emitting stop function, "tr 19": Trigger function
Shift amount setting [for HG-C1000L series only]	<HG-C1030L3-P□> 0020 <HG-C1050L3-P□> 006 <HG-C1100L3-P□> 0.14 <HG-C1200L3-P□> 04 <HG-C1400L3-P□> 16	Set the shift amount for the threshold value when using limit teaching. Be sure to set the shift amount to a value twice the hysteresis setting value or higher. HG-C1030L3-P□: 0.002 to 10.00 mm 0.00008 in to 0.394 in HG-C1050L3-P□: 0.02 to 30.00 mm 0.00079 in to 1.181 in HG-C1100L3-P□: 0.04 to 70.00 mm 0.00157 in to 2.756 in HG-C1200L3-P□: 0.2 to 160.0 mm 0.00787 in to 6.299 in HG-C1400L3-P□: 0.4 to 400.0 mm 0.01575 in to 15.748 in
Timer setting	non	Set the timer operation. The timer time is fixed at 5ms. "non": No timer, "oFd": OFF-delay timer "onD": ON-delay timer, "oSD": One-shot timer
Timer period setting [for HG-C1000L series only]	5	Set the timer period when the timer setting is set to "off-delay timer," "on-delay timer" or "one-shot timer." "5": 5 ms, "10": 10 ms, "25": 25 ms, "50": 50 ms, "100": 100 ms, "250": 250 ms, "500": 500 ms, "1000": 1,000 ms, "5000": 5,000 ms
Display setting	Std	The display of the measured value can be changed. "Std": Normal, "InvL": Invert, "oFSt": Offset
Hold setting	oFF	Set the control output and the analogue output operation when a measurement error occurs (insufficient light intensity, saturation of light intensity, out of measurement range). "oFF": Hold OFF, "on": Hold ON
ECO setting	oFF	The digital display can be set to go OFF when key operation is not performed for 30 seconds. Current consumption can be reduced. "oFF": ECO OFF, "on": ECO ON
Reset setting	no	Return to the default setting (factory setting). "no": Reset NG, "yES": Reset OK

Error indication

- In case of errors, attempt the following measures.

Error indication	Description	Remedy
<Hold OFF> ----- <Hold ON> Measured value blinks	Insufficient amount of reflected light. The sensing object is out of the sensing range.	Confirm that the sensing distance is within the specification range. Adjust the installation angle of the sensor.
Er01	Nonvolatile memory is damaged or is past its life expectancy.	Please contact our office.
Er11	Load of the sensing output is short-circuited causing an over-current to flow.	Turn OFF the power and check the load.
Er21	The semiconductor laser is damaged or is past its life expectancy.	Please contact our office.
Er31	<ul style="list-style-type: none"> • When zero set is set, the measurement is not performed normally. • Since the display setting is set to "Offset", the zero set function can not be used. 	<ul style="list-style-type: none"> • Confirm that the sensing distance is within the specification range. • Set the display to any setting except "Offset."
Er41	During teaching, the measurement is not performed normally.	Confirm that the sensing distance is within the specification range.
Er90 Er91 Er92 Er93	System error	Please contact our office.

Event function (HG-C1000L series)

Error indication	Event code	Error level	State
Er11	0x7710	Fault	DO output short-circuit
Er90 Er91 Er92 Er93	0x1815	Fault	System error
Er01	0x1802	Fault	Nonvolatile memory write error
Er01	0x1803	Fault	Nonvolatile memory CRC error
Er21	0x1810	Fault	Light emission circuit damage
Er31	0x8CB0	Notification	Zero set not possible
Er41	0x8CB2	Notification	Teaching not possible
-----	0x8CA0	Notification	Measurement error (center of gravity computation failure) * Measured value: Transmission of 32764
-----	0x8CA1	Notification	Measurement error (out of specification range, near point side) * Measured value: Transmission of 32000
-----	0x8CA2	Notification	Measurement error (out of specification range, far point side) * Measured value: Transmission of -32000
Display of measured value	0x8CA3	Notification	Low incident light intensity
Display of measured value	0x8D00	Caution	Operating time exceeded
Display of measured value	0x8D01	Caution	Max. number of the nonvolatile memory save operations exceeded

DIMENSIONS (Unit: mm in)

CAD data can be downloaded from our website.

HG-C1□0 HG-C1□0-P

Sensor

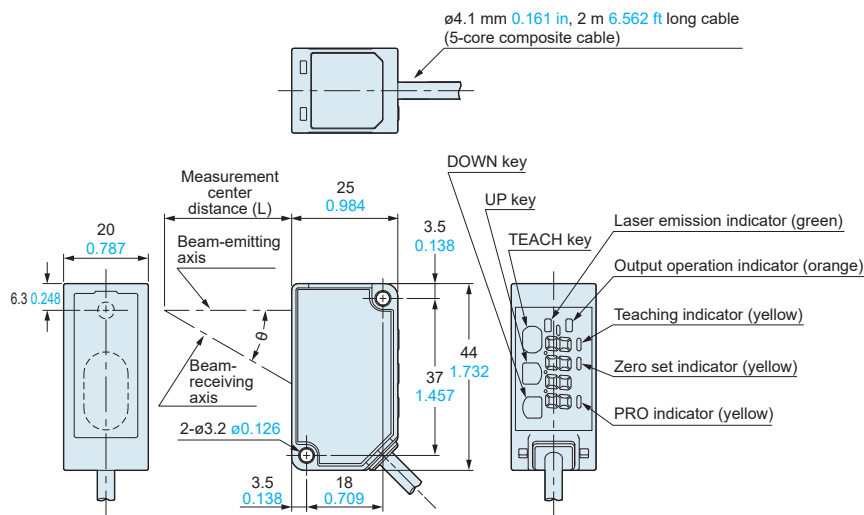

Model No.	Measurement center distance (L)	θ
HG-C1030(-P)	30 1.181	30°
HG-C1050(-P)	50 1.969	22.5°
HG-C1100(-P)	100 3.937	12.5°
HG-C1200(-P)	200 7.874	6.3°
HG-C1400(-P)	400 15.748	3.2°

HG-C□L3-P HG-C□L3-P-J

Sensor

<Discrete wire type HG-C□L3-P>

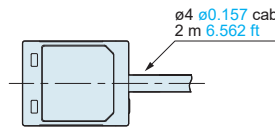

<M12 connector type HG-C□L3-P-J>

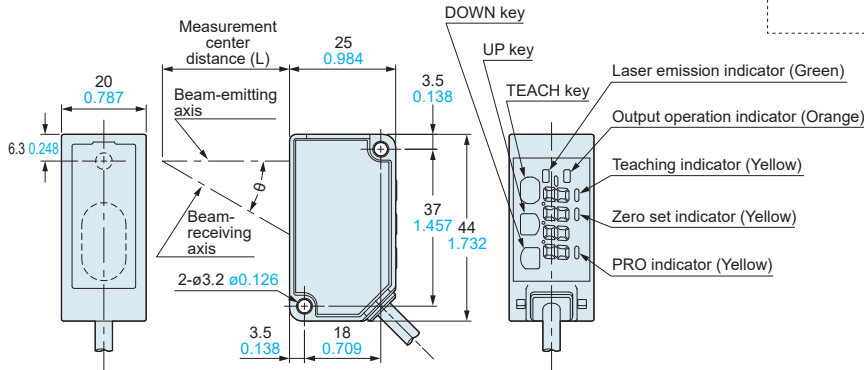
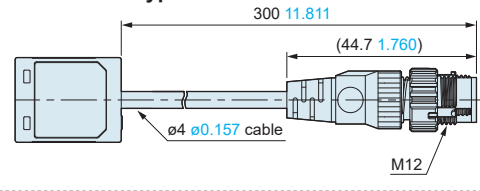

Model No.	Measurement center distance (L)	θ
HG-C1030L3-P(-J)	30 1.181	30°
HG-C1050L3-P(-J)	50 1.969	22.5°
HG-C1100L3-P(-J)	100 3.937	12.5°
HG-C1200L3-P(-J)	200 7.874	6.3°
HG-C1400L3-P(-J)	400 15.748	3.2°

MS-HG-01

Simple mounting bracket (Optional)

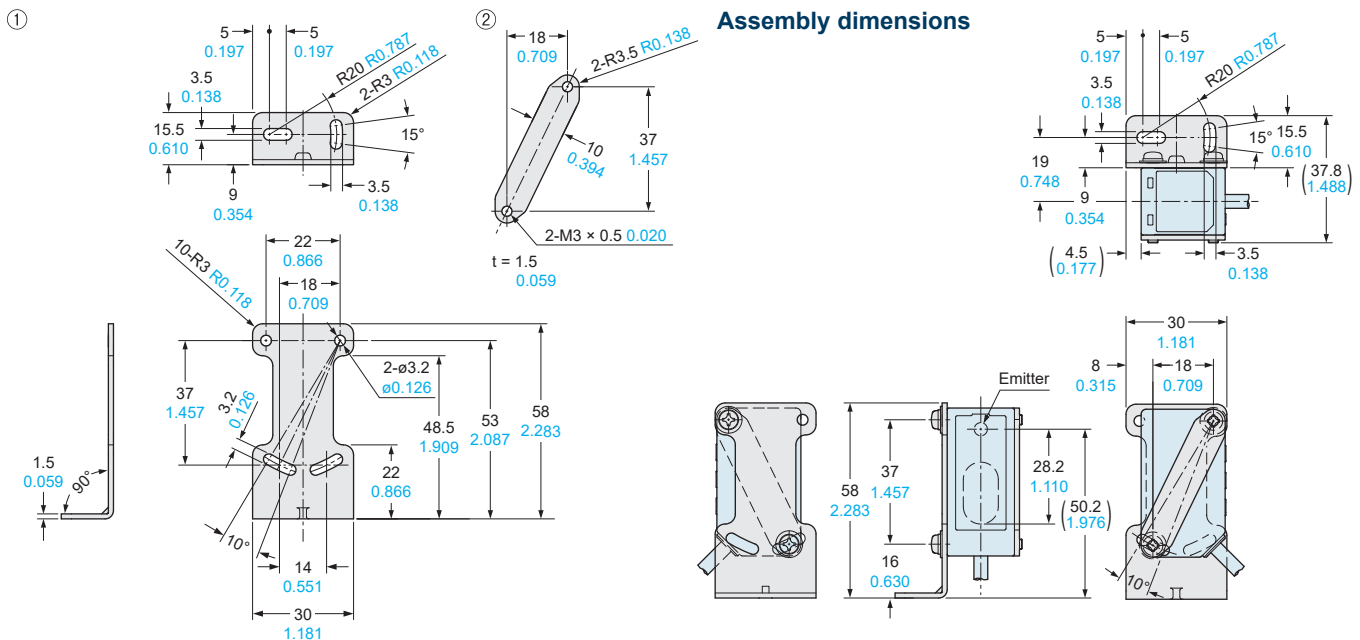

Material: Stainless steel (SUS304)
Two M3 (length 25 mm 0.984 in) screws with washers (SPCC) are attached.

Disclaimer

The applications described in the catalog are all intended for examples only. The purchase of our products described in the catalog shall not be regarded as granting of a license to use our products in the described applications. We do NOT warrant that we have obtained some intellectual properties, such as patent rights, with respect to such applications, or that the described applications may not infringe any intellectual property rights, such as patent rights, of a third party.