

Panasonic

NEW

CMOS type

Micro Laser Distance Sensor

HG-C_{SERIES}

CE
Conforming to
EMC Directive

FDA
Conforming to
FDA regulations

Reliable detection
in **10** μm precision



Compact in size

W20 × H44 × D**25** mm

W0.787 × H1.732 × D**0.984** in

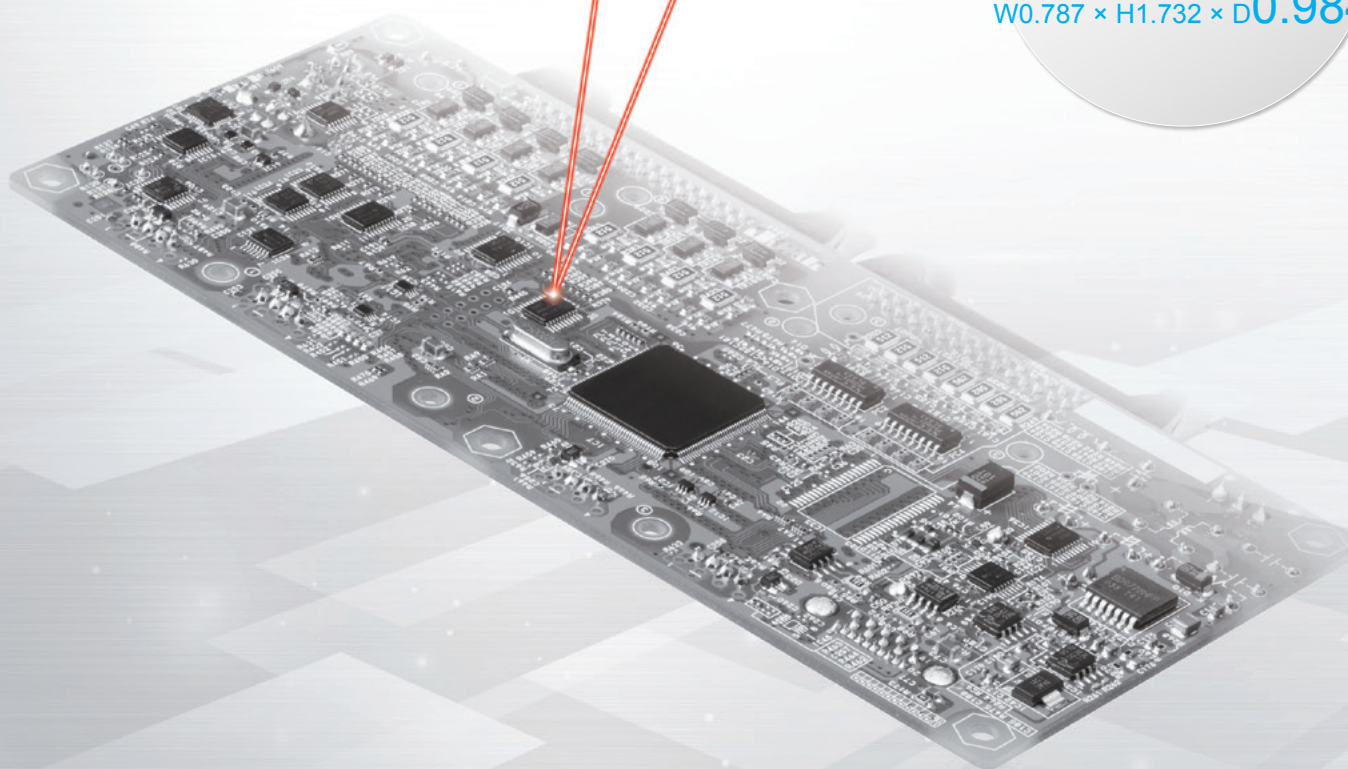

Sensor shown is
the cross-sectional image.

HG-C SERIES

Measurement center distance: 100 mm 3.937 in
 Measurement range: ±35 mm 1.378 in
 Beam diameter: Approx. \varnothing 120 μ m 4.724 mil
 Repeatability: 70 μ m 2.756 mil

Measurement center distance: 50 mm 1.969 in
 Measurement range: ±15 mm 0.591 in
 Beam diameter: Approx. \varnothing 70 μ m 2.756 mil
 Repeatability: 30 μ m 1.181 mil

Measurement center distance: 30 mm 1.181 in
 Measurement range: ±5 mm 0.197 in
 Beam diameter: Approx. \varnothing 50 μ m 1.969 mil
 Repeatability: 10 μ m 0.394 mil

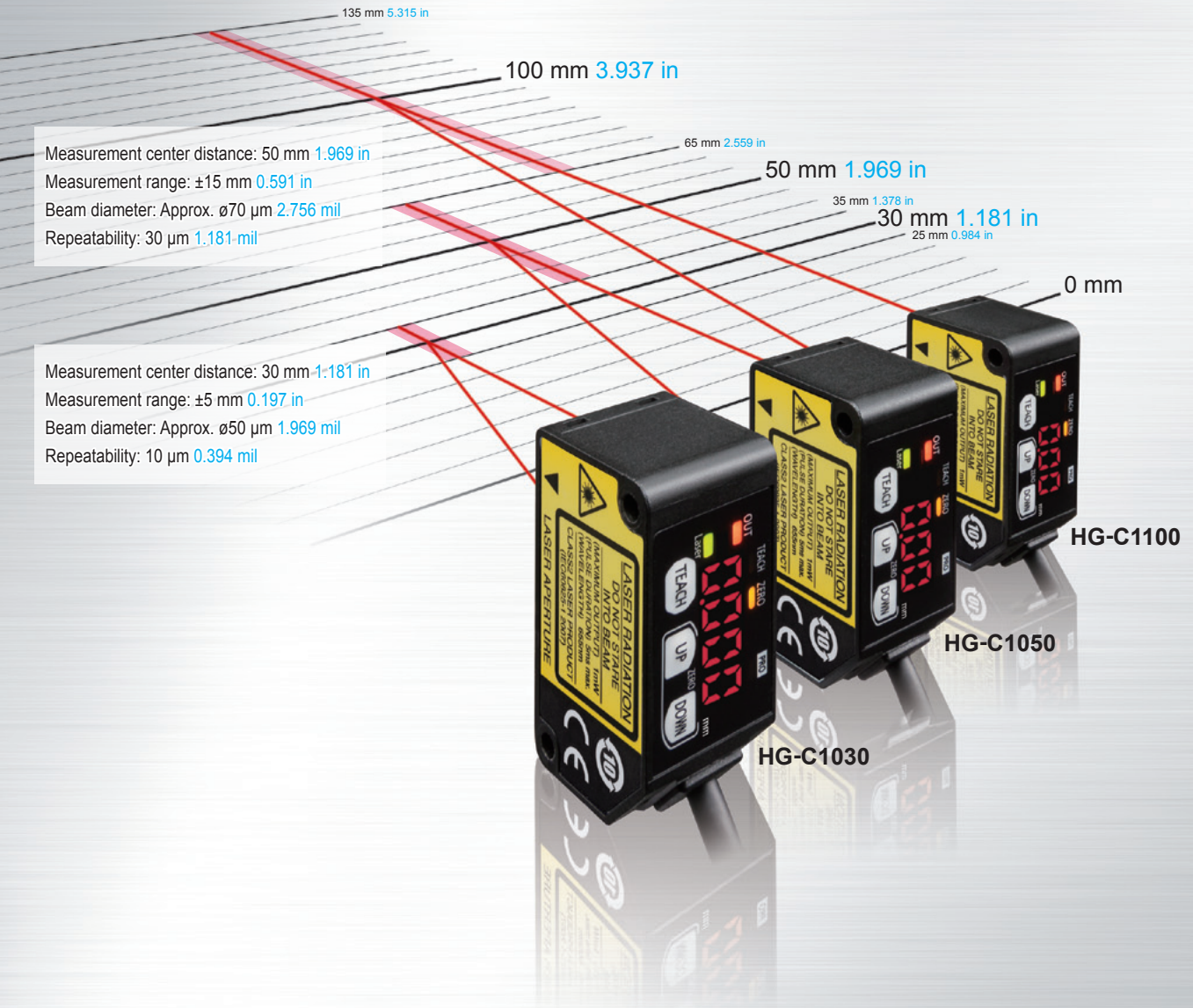

Repeatability: 10 μ m 0.394 mil (for HG-C1030)

Dimensions: W20 × H44 × D25 mm W0.787 × H1.732 × D0.984 in

HG-C SERIES

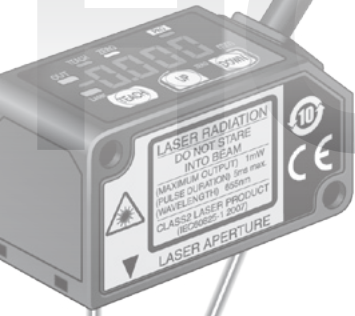

Indicates real measurements

Linearity: $\pm 0.1\%$ F. S.

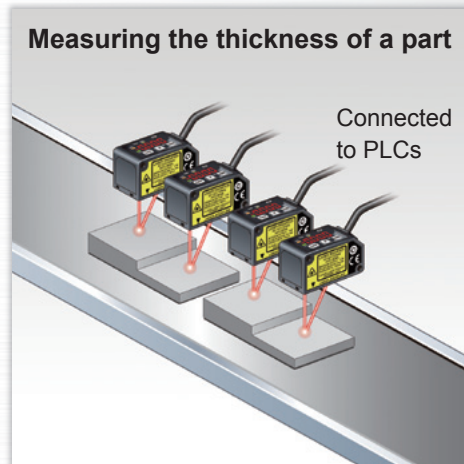
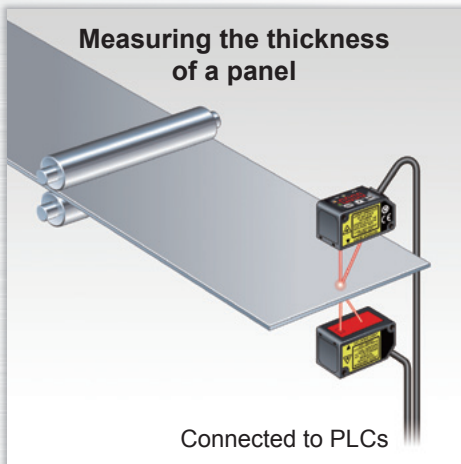
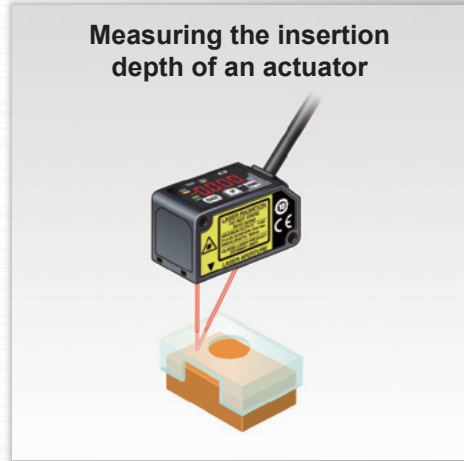
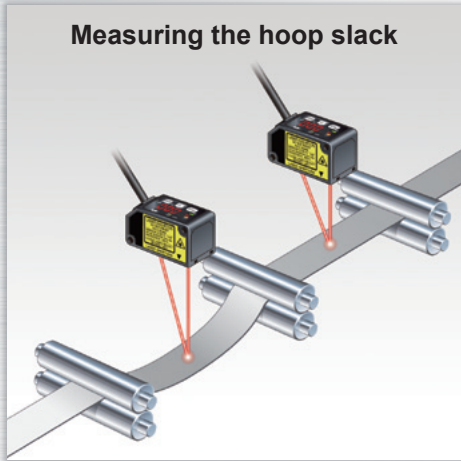

Equipped with 0-5 V analog output • Linearity: $\pm 0.1\%$ F. S. Same as for a high-precision sensor.
 • Temperature characteristics: 0.03%F.S./C

The sensor not only indicates measured values in mm but also produces analog voltage outputs. Various calculations and storage (logging) can be performed when output is taken into a PLC + analog unit.

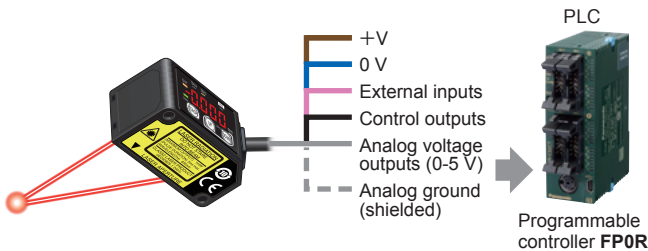

- FP0R-C10 control unit (w/RS232C port) AFP0RC10CRS
- A/D converter unit w/8 input channels (terminal block type) AFP0401

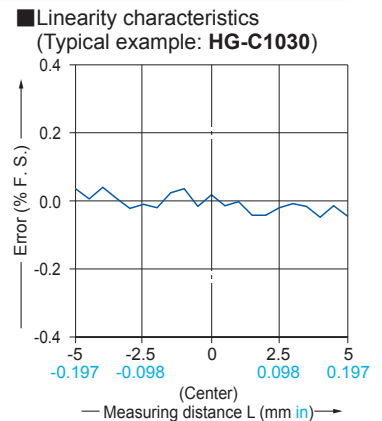

Compact and light-weight

W20 × H44 × D25 mm **W0.787 × H1.732 × D0.984 in**, approx. 35 g (excluding the cable)

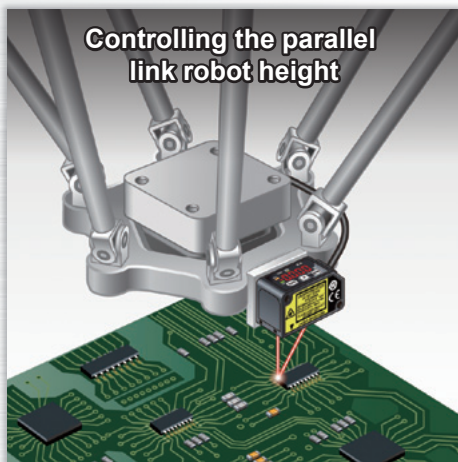
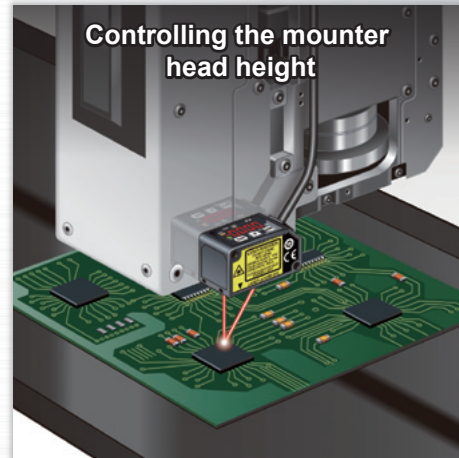
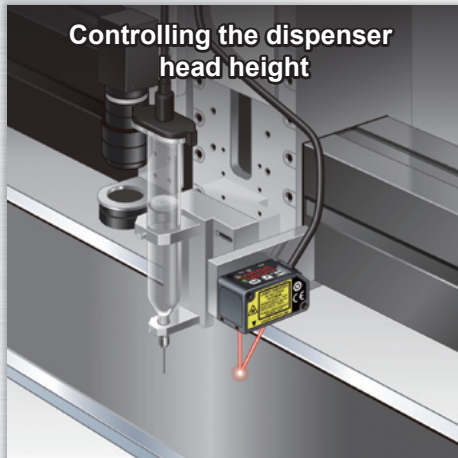

Remove water droplets on detection surface to achieve correct measurement.

A new optical system with a built-in mirror

In general, more accurate and stable measurements can be obtained by increasing the optical path length between the receptor and the light receiving element (CMOS), but this also increases the sensor depth and the sensor body gets bigger. The **HG-C** series sensors incorporating a new optical system with a built-in mirror provides smaller sensor depth as well as higher measurement accuracy equivalent to displacement sensors.

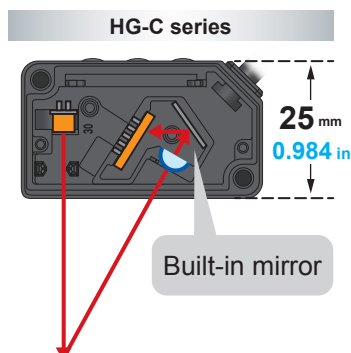

An aluminum die-cast casing protects from strain and heat

A light-weight but strong die-cast aluminum casing has been adopted. A compact, solid body casing reduces the impact of strain and heat on the measurement accuracy.



Overwhelmingly stable

Precise measurements on the order of 1/100 mm **0.0003 inch**

Excellent level detection performance

Repeatability: 10 μm **0.394 mil** (for HG-C1030)

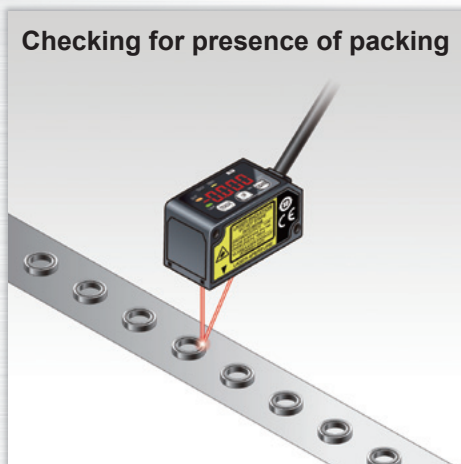
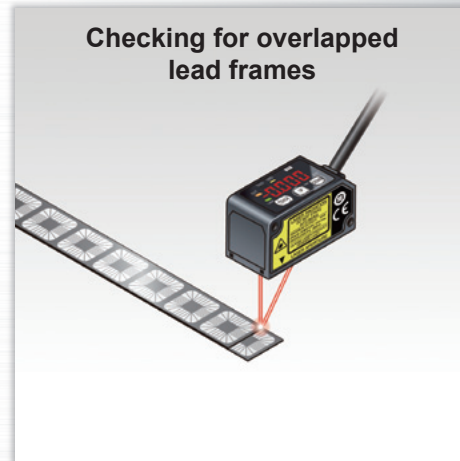
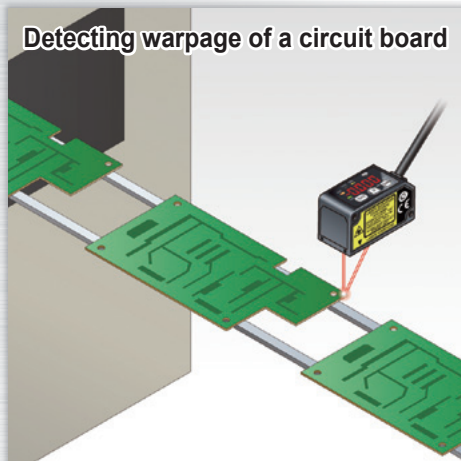

Fitted with a precise CMOS image sensor and an original algorithm

Thanks to a precise CMOS image sensor, it is now possible to perform highly precise measurements in the order of 1/100 mm **0.0003 in**. The existing adjustable range reflective sensors cannot achieve such accuracy.

Example: HG-C1030

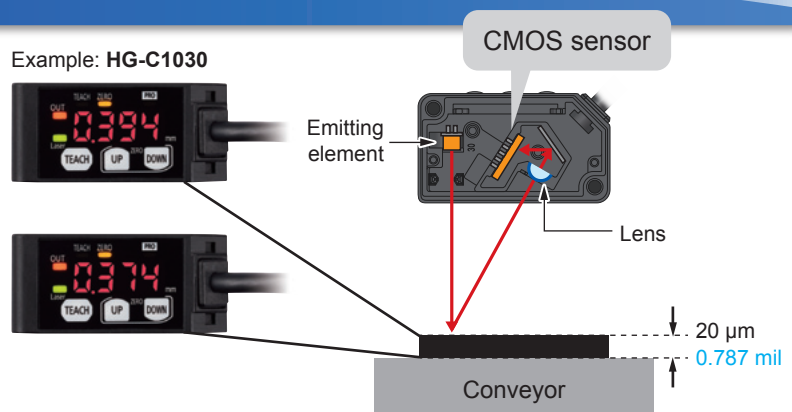

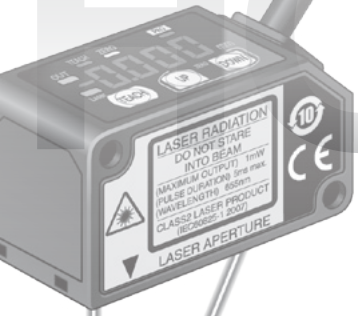

Useful functions

Teaching & window comparator mode

With an object below the sensor, press the TEACH key to set the valid range for distances via threshold values. There are 3 methods for setting the valid range: 1-point, 2-point, and 3-point teaching.

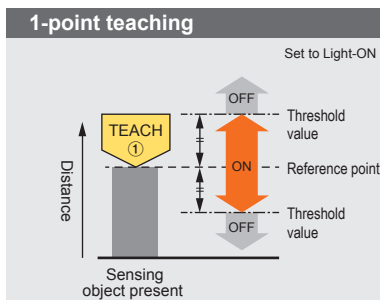

Perform 1-point teaching and the threshold range is set for the distance from the reference surface of the sensing object.

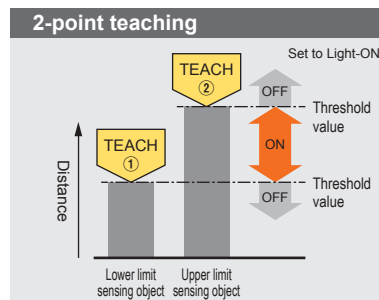

Press TEACH once for the lower (first point) and once for the upper limit (second point). Useful for sensing objects at different distances.

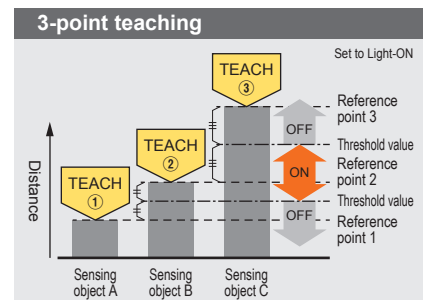

This is the method to set the threshold range by conducting the teaching at 3 points (sensing object A, B and C). After teaching, the reference points are automatically sorted in ascending order (reference point 1, 2 and 3). The thresholds are set at the midpoints between reference point 1 and 2, and 2 and 3, respectively. Useful for sensing objects at different distances.

In addition to the teaching & window comparator mode, the “**rising differential mode**”, “**trailing differential mode**” and “**normal sensing mode**” are available. In normal sensing mode, “**2-point teaching**” as basic teaching and “**limit teaching**,” which is useful for very small objects and backgrounds, are possible.



Timer setting function

The time mode options are “off-delay timer,” “on-delay timer,” “one-shot timer” and “no timer.” The counting time is fixed to 5 ms.

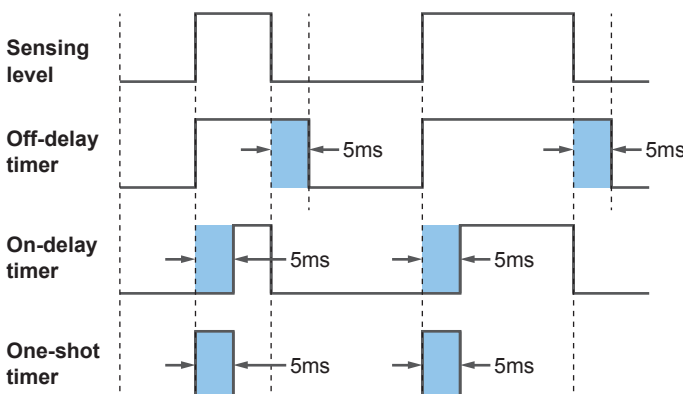

Off-delay timer

Function: Extends output signals by 5 ms.
Usage: Appropriate in case a connected device is slow to respond and ON time is required to extend.

On-delay timer

Function: Overrides output signals for 5 ms after detection.
Usage: Convenient way to override temporary signals and control with a time lag.

One-shot timer

Function: Sends output signals for only 5 ms after detection.
Usage: Useful when the signal duration needs to be constant to meet inputs from a connected device. This mode is also used to extend temporary signals by a desired length of time.

Zero set function

This function compulsorily sets the measured value to "zero." The zero point can be set at a desired value. It is useful when measuring steps or tolerance with reference to the height of a sensing object.

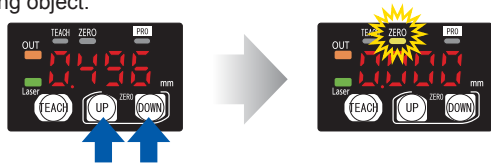

Keep pressing both keys for 3 seconds.

- * The zero set indicator (yellow) will turn ON while the zero set is valid.
- * When the zero set function is executed while the peak hold function or the bottom hold function is valid, the held measurement value is reset.
- * When the display setting is set to offset, the zero set function cannot be set.

External input setting function

One of four functions, "zero setting function," "teaching function," "emission stopping function" and "trigger function" can be assigned to an external input line.

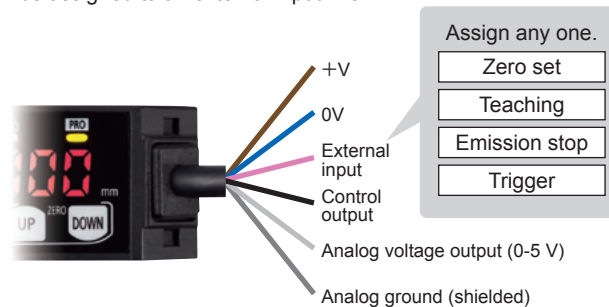

Display setting function

How to indicate measured values of the moving sensed object can be chosen from three options, "Normal," "Invert" and "Offset."

	Normal	Invert	Offset
Near measuring point	15.00 mm	-15.00 mm	30.00 mm
Center measuring point	0.00 mm	0.00 mm	15.00 mm
Far measuring point	-15.00 mm	15.00 mm	0.00 mm

* The above display is for HG-C1050

Peak and bottom hold functions

The peak hold function holds the maximum measured value which is output and displayed.

The bottom hold function holds the minimum measured value which is output and displayed.

- * The peak hold function and the bottom hold function cannot be set at the same time.
- * When the zero set function is executed while the peak hold function or the bottom hold function is valid, the held measurement value is reset.

Threshold value fine adjustment function

Fine adjustment of threshold values can be performed while measurement is proceeding on the display, and even after teaching.

Key lock function

This function protects setting conditions from unintentional changes.

* For other functions and procedures for setting the functions, see "PRO Mode Setting" from page 10.

ORDER GUIDE

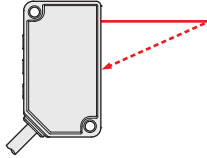
Type	Appearance	Measurement center distance and measurement range	Repeatability	Beam diameter (Note 1)	Model No.	
					NPN output	PNP output
Measurement center 30mm 1.181 in type		30 ± 5 mm 1.181 ± 0.197 in	10 µm 0.394 mil	Approx. ø50 µm 1.969 mil	HG-C1030	HG-C1030-P
Measurement center 50mm 1.969 in type		50 ± 15 mm 1.969 ± 0.591 in	30 µm 1.181 mil	Approx. ø70 µm 1.181 mil	HG-C1050	HG-C1050-P
Measurement center 100mm 3.937 in type		100 ± 35 mm 3.937 ± 1.328 in	70 µm 2.756 mil	Approx. ø120 µm 4.724 mil	HG-C1100	HG-C1100-P

Note 1: This is the size in the measurement center distance. These values were defined by using 1/e² (approx. 13.5%) of the center light intensity. Due to leak light outside the specified area, the reflectance around the detecting point may be higher than at the point and this may affect the measurement value.

SPECIFICATIONS

Item	Type	Measurement center 30mm type	Measurement center 50mm type	Measurement center 100mm type
	Model No.			
	NPN output	HG-C1030	HG-C1050	HG-C1100
	PNP output	HG-C1030-P	HG-C1050-P	HG-C1100-P
Applicable standard				
EMC Directive Compliance, FDA Standard				
Measurement center distance		30 mm 1.181 in	50 mm 1.969 in	100 mm 3.937 in
Measurement range		±5 mm 0.197 in	±15 mm 0.591 in	±35 mm 1.328 in
Repeatability		10 µm 0.394 mil	30 µm 1.181 mil	70 µm 2.756 mil
Linearity		±0.1% F.S.		
Temperature characteristic		0.03% F.S./°C		
Light source		Red semiconductor laser Class 2 (JIS/IEC/GB)/Class II (FDA) (Note 2) Max. output: 1mW, emission peak wavelength: 655nm 0.026 mil		
Beam diameter (Note 3)		Approx. ø50 µm 1.969 mil	Approx. ø70 µm 1.181 mil	Approx. ø120 µm 4.724 mil
Supply voltage		12 to 24V DC ±10%, Ripple P-P 10% or less		
Power consumption		40 mA or less (at 24V DC supply voltage), 60 mA or less (at 12V DC supply voltage)		
Control output		<NPN output type> NPN open-collector transistor • Maximum sink current: 50mA • Applied voltage: 30V DC or less (Between control output to 0V) • Residual voltage: 1.5V or less (At 50mA sink current) • Leakage current: 0.1 mA or less	<PNP output type> PNP open-collector transistor • Maximum source current: 50mA • Applied voltage: 30V DC or less (Between control output to +V) • Residual voltage: 1.5V or less (At 50mA source current) • Leakage current: 0.1 mA or less	
Output operation		Either Light-ON or Dark-ON		
Short-circuit protection		Incorporated (Auto reset type)		
Analogue output		• Output range: 0 to 5V (at alarm: +5.2V) • Output impedance: 100Ω		
Response time		Switchable between 1.5 ms / 5 ms / 10 ms		
External input		<NPN output type> NPN non-contact input • Input conditions Invalid: +8 to +V DC or Open Valid: 0 to +1.2V DC • Input impedance: Approx. 10kΩ	<PNP output type> PNP non-contact input • Input conditions Invalid: 0 to +0.6V DC or Open Valid: +4 to +V DC • Input impedance: Approx. 10kΩ	
Degree of pollution		2		
Operating altitude		2,000 m 6561.680 ft or less		
Environmental durability	Protection	IP67 (IEC)		
	Ambient temperature	-10 to +45°C -14 to 113°F (No dew condensation or icing allowed), Storage: -20 to +60°C -4 to 140°F		
	Ambient humidity	35 to 85% RH, Storage: 35 to 85% RH		
	Ambient illuminance	Incandescent lamp: Acceptance surface illuminance 3,000lx or less		
Cable		5-core composite cable, 2 m 6.5617 ft long		
Material		Enclosure: Aluminum die-cast, Front cover: Acrylic		
Weight		Net weight: approx. 35 g (without cable), approx. 85 g (including cable)		

Notes: 1) Supply voltage: 24V DC, ambient temperature: +20°C +68°F, response time: 10ms, and analog output value of measurement center distance are used for unspecified measurement conditions. The subject is white ceramics.
 2) This is based on the FDA Standard, according to Laser Notice No. 50 of the FDA Standard.
 3) This is the size in the measurement center distance. These values were defined by using 1/e² (approx. 13.5%) of the center light intensity. Due to leak light outside the specified area, the reflectance around the detecting point may be higher than at the point and this may affect the measurement value.

I/O CIRCUIT AND WIRING DIAGRAMS

NPN output Type

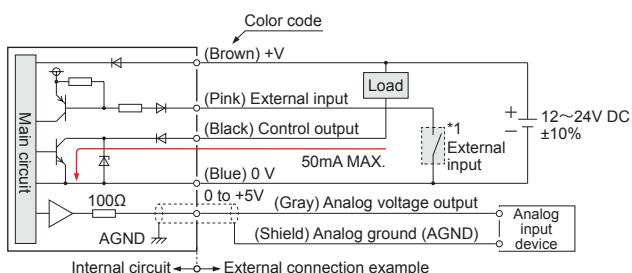

*1

Non-voltage contact or NPN transistor / open-collector

- External input
- Invalid: +8 to +V DC or open
- Valid: 0 to +1.2V DC

PNP output Type

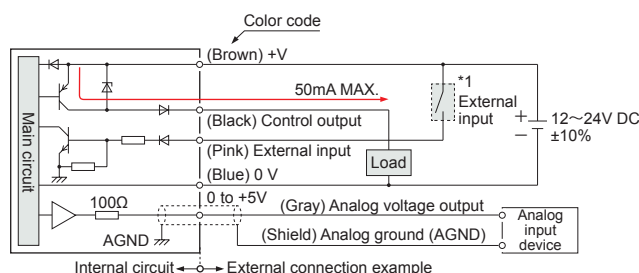

*1

Non-voltage contact or PNP transistor / open-collector

- External input
- Invalid: 0 to +0.6V DC or open
- Valid: +4 to +V DC

SENSING CHARACTERISTICS (TYPICAL)

Linearity

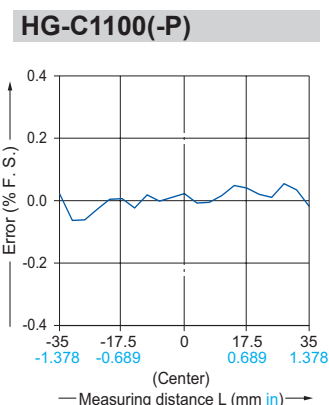
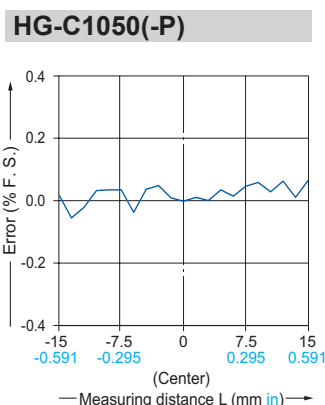
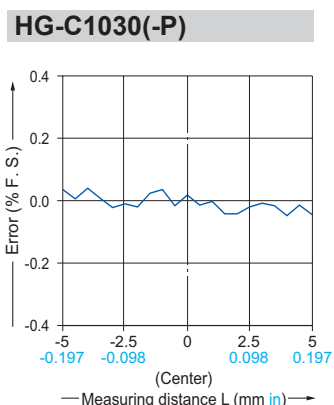
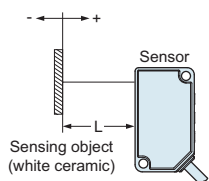

PRECAUTIONS FOR PROPER USE

• This catalog is only provided to help choose a product and the user's guide attached to the product must be read before use.

⚠

- Never use this product as a sensing device for personnel protection.
- In case of using sensing devices for personnel protection, use products which meet laws and standards, such as OSHA, ANSI or IEC etc., for personnel protection applicable in each region or country.

⚠

- Do not operate products using methods other than the ones described in the instruction manual included with each product. Control or adjustment through procedures other than the ones specified may cause hazardous laser radiation exposure.

- This product is classified as a Class 2 Laser Product under JIS / IEC / GB standards and as a Class II * Laser Product under FDA regulations. Do not look at the laser beam directly or through an optical system such as a lens.
- The warning label (English) is attached to the product. Handle the product according to the instruction given on the warning label. (The warning labels in Japanese and Chinese are packed with the sensor.)

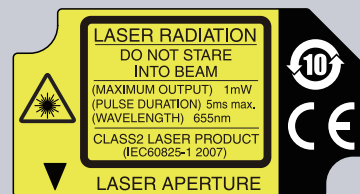

* The product complies with the FDA regulations and satisfies requirements of the FDA's Laser Notice No. 50.

PRECAUTIONS FOR PROPER USE

Part description

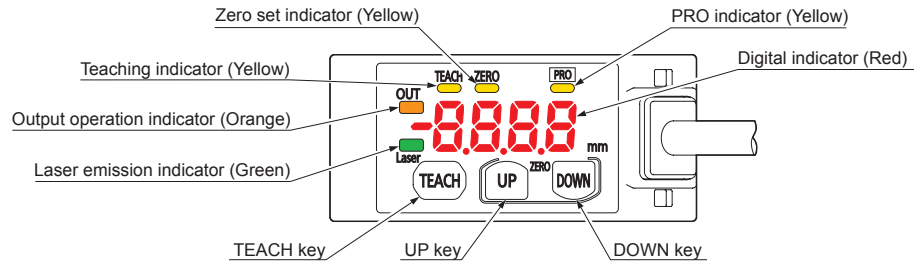

PRO mode setting

Part description

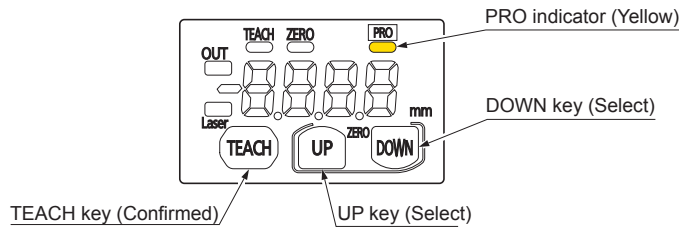

- The PRO indicator (yellow) will turn ON when the PRO mode is set.
- When the DOWN key is pressed for 3 seconds or more in the middle of the PRO MODE setting, the display returns to the measurement display.

Item	Default setting	Description
Response speed setting	Hr50	Set the response time. "Hr50": High precision 10ms, "Std": Standard 5ms, "Fast": High speed 1.5ms
Output operation setting	L-on	Select the control output operation mode. "L-on": Light-ON, "d-on": Dark-ON
Sensing output setting	--F--	Set the sensing output. "--F--": Normal sensing mode "A.1": 1-point teaching (Window comparator mode) "A.2": 2-point teaching (Window comparator mode) "A.3": 3-point teaching (Window comparator mode) "d.F": Rising differential mode "d.L": Trailing differential mode
Hysteresis setting	<HG-C1030> 0010 <HG-C1050> 003 <HG-C1100> 007	Set the hysteresis width. HG-C1030: 0.001 to 5.00 mm 0.00004 to 0.197 in HG-C1050: 0.01 to 15.00 mm 0.00040 to 0.591 in HG-C1100: 0.02 to 35.00 mm 0.00079 to 1.378 in
External input setting	0Set	Set the external input. "0Set": Zero set function, "tEch": Teaching function "L-of": Light emitting stop function, "tr 19": Trigger function
Timer setting	non	Set the timer operation. The timer time is fixed at 5ms. "non": No timer, "ofd": OFF-delay timer "ond": ON-delay timer, "osd": One-shot timer
Display setting	Std	The display of the measured value can be changed. "Std": Normal, "Invt": Invert, "oFSt": Offset
Hold setting	oFF	Set the control output and the analogue output operation when a measurement error occurs (insufficient light intensity, saturation of light intensity, out of measurement range). "oFF": Hold OFF, "on": Hold ON
ECO Setting	oFF	The digital display can be set to go OFF when key operation is not performed for 30 seconds. Current consumption can be reduced. "oFF": ECO OFF, "on": ECO ON
Reset setting	no	Return to the default setting (factory setting). "no": Reset NG, "yES": Reset OK

PRECAUTIONS FOR PROPER USE

Procedure

Measurement display



↓ DOWN: Press for 3 seconds

Response time setting



↑ UP / DOWN

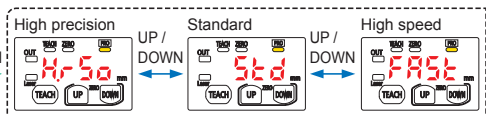

Output operation setting

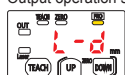

↑ UP / DOWN

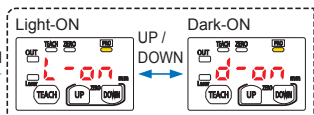

Sensing output setting



↑ UP / DOWN

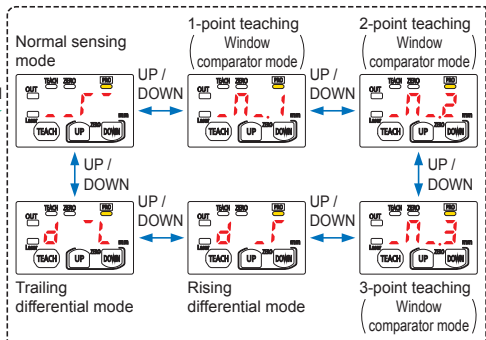

Hysteresis setting



↑ UP / DOWN

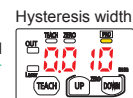

UP key : Increases hysteresis width
DOWN key : Decreases hysteresis width

External input setting



↑ UP / DOWN

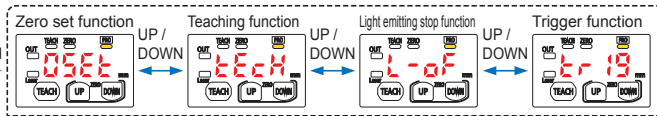

Timer setting



↑ UP / DOWN

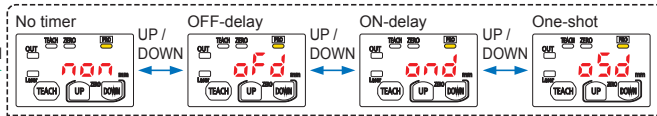

Display setting



↑ UP / DOWN

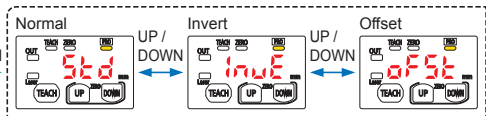

Hold setting



↑ UP / DOWN

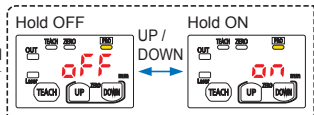

ECO Setting



↑ UP / DOWN

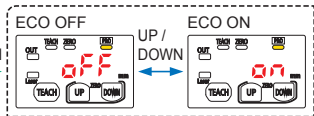

Reset setting



↑ UP / DOWN

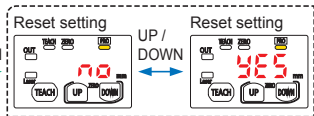

Response time setting



<Arrow description in figures>

- ↔ : Press the TEACH key
- ↕ : Press UP key or DOWN key
- ⬇ : Press DOWN key

PRECAUTIONS FOR PROPER USE

Mounting

- When mounting this product, use M3 screws (prepare separately). Use a tightening torque of 0.5 N·m for mounting.

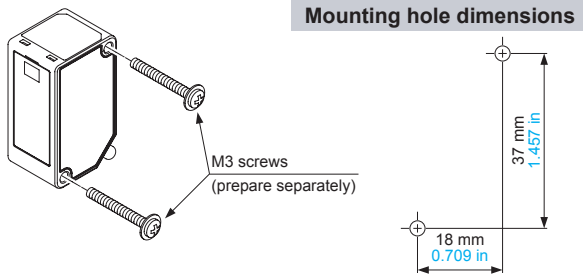

Mounting Direction

• Direction to a movable body

<When there are differences in material and color>

- When performing measurements of moving objects with excessively different materials and colors, mount the product per the following directions to minimize measurement errors.

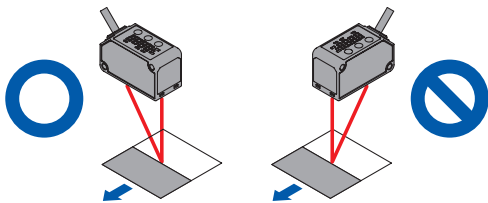

<Measurement of rotating objects>

- When measuring rotating objects, mount the product as follows. Measurement can be performed with minimized effect on the object caused by up / down deflection, position deviation and etc.

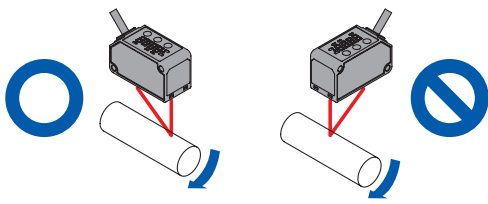

<When there is a step>

- When there is a step in the moving object, mount the product as follows. Measurement can be performed with minimized effect from the edges of the steps.

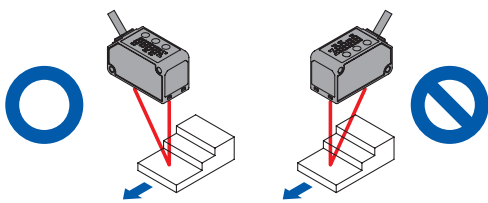

• Measuring of narrow locations and recesses

- When measuring in narrow locations or inside holes, mount the product so that optical path from the light-emitting part to light-receiving part is not interrupted.

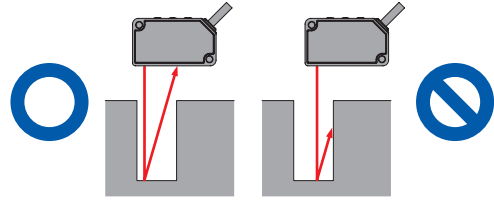

• When mounting the product on a wall

- Mount the product as follows, so that the multiple light reflections on the wall do not emit to the light-receiving part. When the reflection factor on a wall is high, it is effective to use a dull black color.

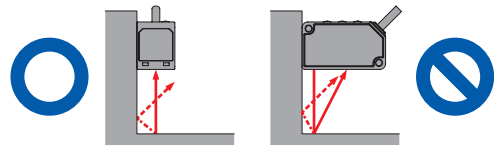

Others

- This product has been developed / produced for industrial use only.
- Make sure that the power supply is OFF before starting the wiring.
- If the wiring is performed incorrectly, it will cause a failure.
- Do not run the wires together with high-voltage lines or power lines, or put them in the same raceway. This can cause malfunction due to induction.
- Verify that the supply voltage variation is within the rating.
- If power is supplied from a commercial switching regulator, ensure that the frame ground (F.G.) terminal of the power supply is connected to an actual ground.
- If noise generating devices (switching regulators, inverter motors, etc.) are used around the sensor mounting area, make sure to connect the frame ground (FG) terminal of the device.
- Do not use this product during the transient state when the power supply is turned ON.
- The overall length of the cable can be extended to 10m maximum with a cable size of 0.3mm² or more.
- Make sure that stress by forcible bend or pulling is not applied to the sensor cable joint.
- Although it depends on the type, light from rapid start type or high frequency lighting type fluorescent lights, sunlight and etc. may affect the sensing, therefore make sure to prevent direct incident light.
- This product is suitable for indoor use only.
- Keep water, oil, fingerprints and etc. which reflect light, or dust, particles or etc. which interrupts the light, away from the emitting / receiving surfaces of this product. If contaminants adhere to the surface, wipe off with a dust-free soft cloth, or lens cleaning paper.
- Do not use the sensor in locations where there is excessive vapor, dust or etc. or in an atmosphere where corrosive gases, etc. is generated.
- Take care that the product does not come in contact with oil, grease, organic solvents such as thinner, etc., strong acid or alkaline.
- Make sure to turn OFF the power supply, before cleaning the light emitting / receiving windows of the sensor head.

PRECAUTIONS FOR PROPER USE

Error indication

• In case of errors, attempt the following measures.

Error indication	Description	Remedy
<Hold OFF> ----- <Hold ON> Measured value blinks	Insufficient amount of reflected light. The sensing object is out of the sensing range.	Confirm that the sensing distance is within the specification range. Adjust the installation angle of the sensor.
E-01	Flash memory is damaged or is past its life expectancy.	Please contact our office.
E-11	Load of the sensing output is short-circuited causing an over-current to flow.	Turn OFF the power and check the load.
E-21	The semiconductor laser is damaged or is past its life expectancy.	Please contact our office.
E-31	<ul style="list-style-type: none"> When zero set is set, the measurement is not performed normally. Since the display setting is set to "Offset", the zero set function can not be used. 	<ul style="list-style-type: none"> Confirm that the sensing distance is within the specification range. Set the display to any setting except "Offset."
E-41	During teaching, the measurement is not performed normally.	Confirm that the sensing distance is within the specification range.
E-90 E-91 E-92 E-93	System error	Please contact our office.

DIMENSIONS (Unit: mm in)

CAD data can be downloaded from our website.

HG-C **Sensor**

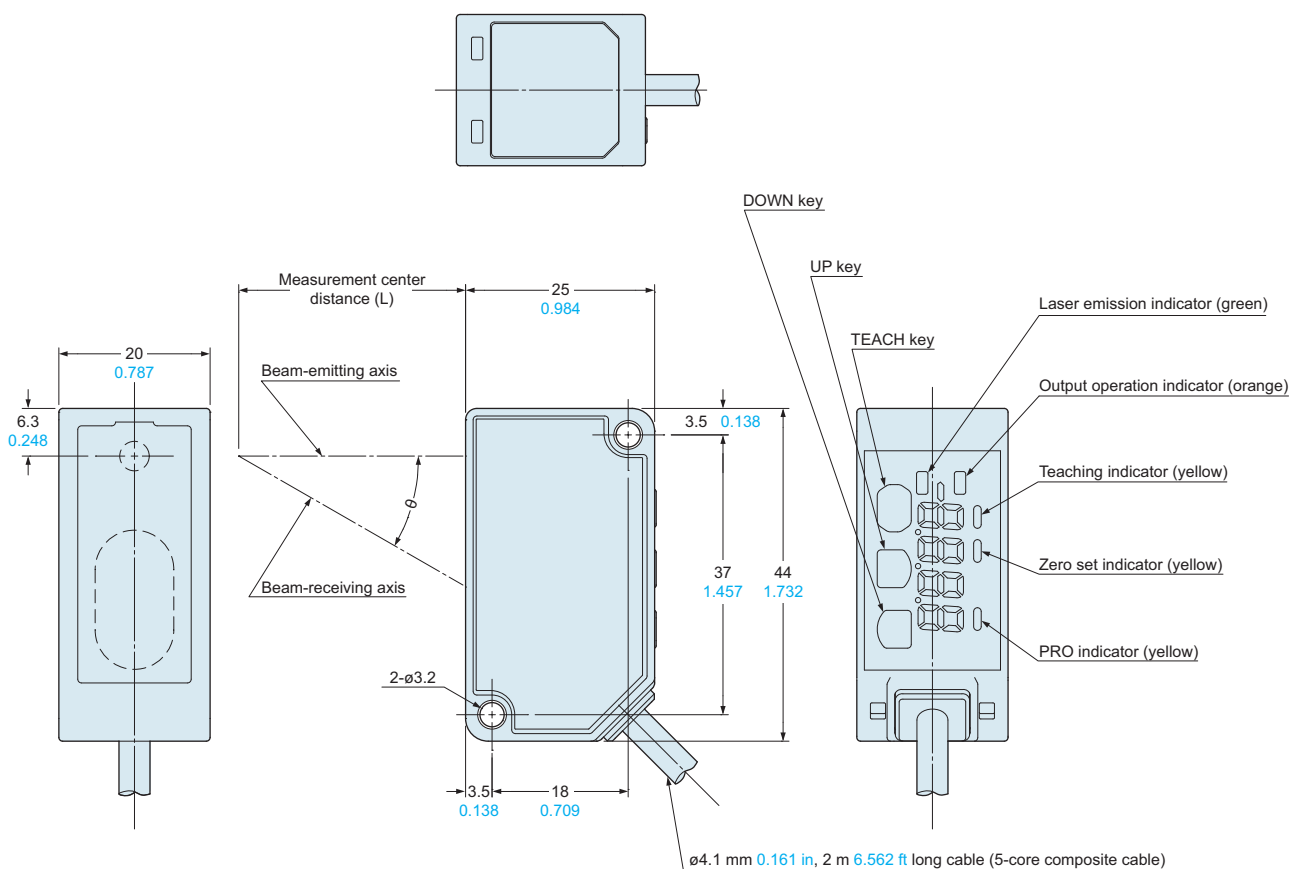

Model No.	Measurement center distance (L)	θ
HG-C1030(-P)	30 1.181	30°
HG-C1050(-P)	50 1.969	22.5°
HG-C1100(-P)	100 3.937	12.5°

Introducing our laser sensors

Laser Displacement Sensor **Compact** **HL-G1**SERIES

High-precision measurement is achieved at a resolution of $0.5\ \mu\text{m}$ **0.02 mil** (HL-G103□). Easy to embed in machines and production lines thanks to a built-in controller.



Full lineup! 10 models of diffuse reflection type (class 2) and 6 models of specular reflection type (class 1) are available. They accommodate a variety of applications.

Digital Laser Sensor **Amplifier-separated** **LS-500**SERIES

Industry's smallest* laser sensor head, fastest response time* 60 μs .

* As of September 2013, as amplifier-separated type laser sensor amplifier, based on research conducted by us.

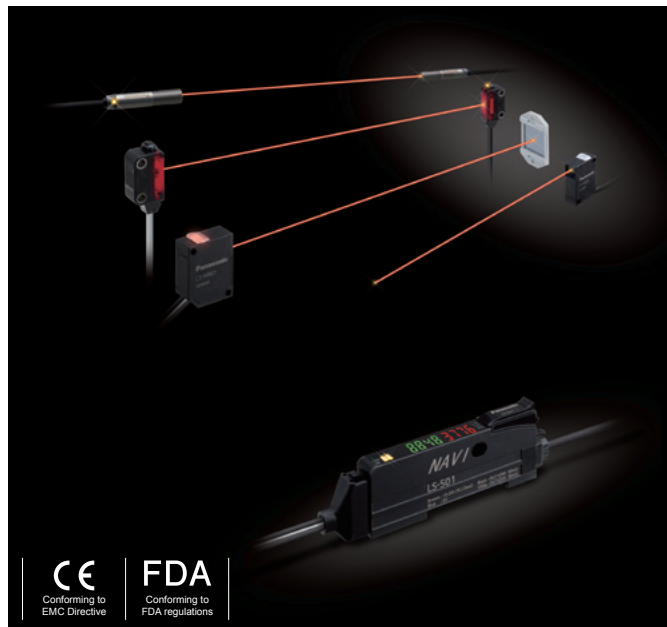

Engineered for maximum compatibility with fiber sensors in every aspect of its design, form and operability. The LS-500 delivers an environment that makes it easy to choose a class 1 laser sensor.

Please contact

Panasonic Industrial Devices SUNX Co., Ltd.

2431-1 Ushiyama-cho, Kasugai-shi, Aichi, 486-0901, Japan
Global Sales Department
■ Telephone: +81-568-33-7861 ■ Facsimile: +81-568-33-8591
panasonic.net/id/pidsx/global

Panasonic®

All Rights Reserved ©Panasonic Industrial Devices SUNX Co., Ltd. 2014