



AUDIN
8 avenue de la malle
51370 St Brice Courcelles - France
Tel. +33(0)326042021 • Fax +33(0)326042820
<http://www.audin.fr> • e-mail info@audin.fr

PICKING SENSOR **Anti-absentmindedness**

New

Compact-size

NA1-PK3 SERIES

Standard

NA1-PK5 SERIES



Preventing the Picking of Incorrect Parts

Contributing to productivity improvement with a large, high-visibility job indicator and an enhanced variety of products.

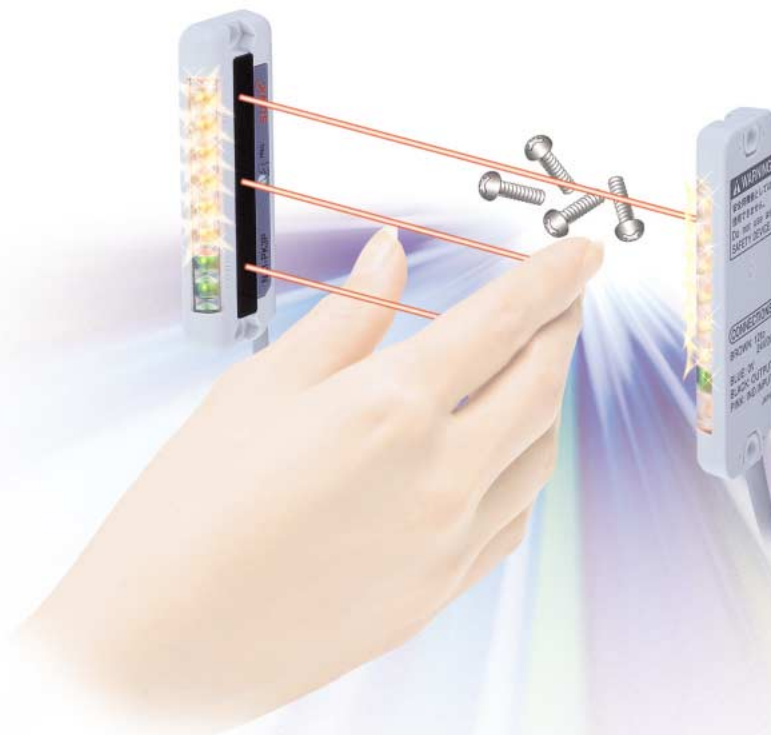

The use of picking sensors prevents the picking of incorrect parts during assembly and packaging operations.

As the conventional picking process relies solely upon human skills, parts picking errors are inevitable, resulting in reduced production efficiency. In contrast, picking systems incorporating picking sensors allow the operators to simply select the proper parts in accordance with guidance provided by the job indicator light, thus greatly reducing the occurrence of human error. The end result is a significant improvement in production efficiency.



① The job indicator light at the parts box from which the next part is to be picked then becomes illuminated.

② The part is then picked from the parts box with the illuminated job indicator light.

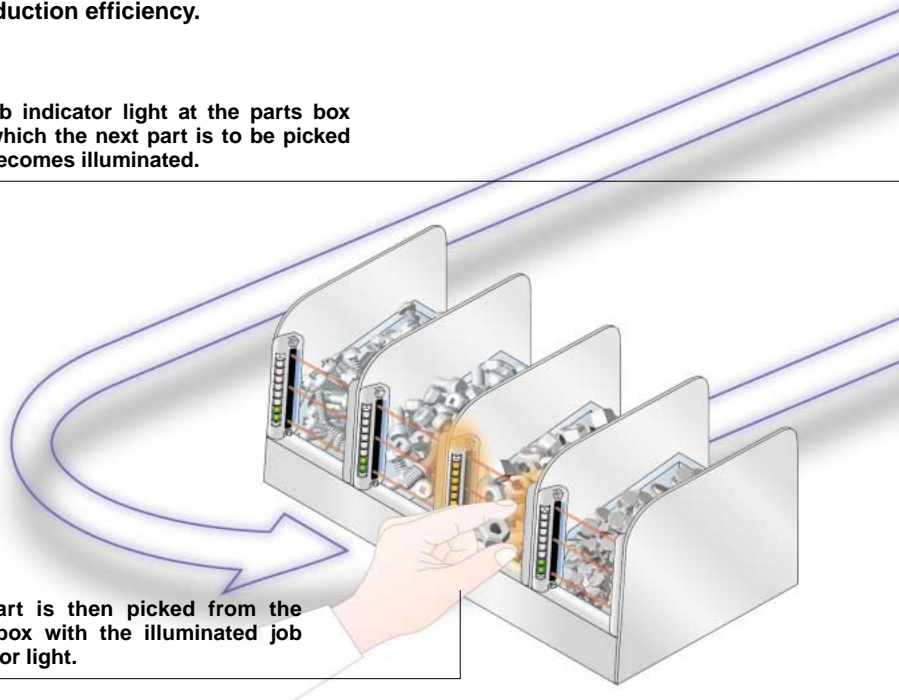

Compact-size Picking Sensor NA1-PK3 series

Space-saving, pocket lighter-sized unit

Ultra compact size: W242 × H702 × D8mm
W0.945 × H2.756 × D0.315in
Can even be mounted within the small space constraints of parts containers.



Utilizes a large, bright, easy-to-see job indicator

The ultra compact body incorporates a job indicator approximately 50mm 1.969in tall. Due to its brightness and high visibility, it is now possible to check sensor operation from a distance.

No synchronization wires required

Synchronization wires are not required, due to the utilization of a synchronized scanning system that results in a reduction of wiring man-hours. In addition, the sensors can be switched among three different emission frequencies, allowing up to three sets of sensors to be installed closely together in the same vertical plane, without causing mutual interference. Even when installed in multistage shelving, malfunctions due to mutual interference will not occur. (When mounted horizontally, a maximum of two sensor sets may be used side-by-side, without interference.)



Switchable output operation

Output operation can be switched to suit the desired application.

Easy alignment

The sensor's beam axis is directly in line with the mounting holes, making sensor alignment very easy. Mounting can be performed simply by using M4 nuts.



Flexible cable orientation

The cabling can be oriented in either of two different directions: down or to the side, thus permitting a flexible layout, in accordance with the sensor's mounting position.



Sensor protection brackets are available

Sensor protection brackets are now available (optional), to protect sensors from damage due to tools and other objects. The protection brackets have a black coating, which enhances the visual effectiveness of the job indicator.



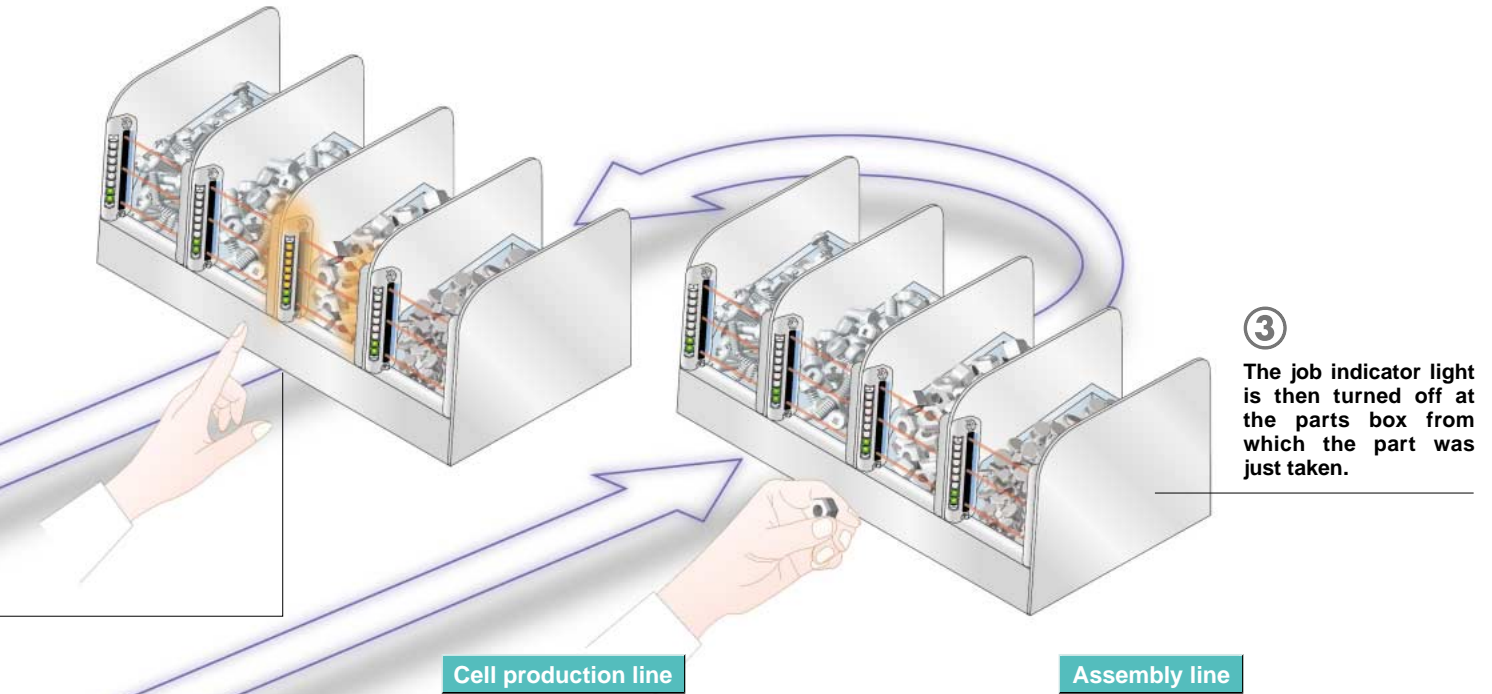

Cell production line

Assembly line

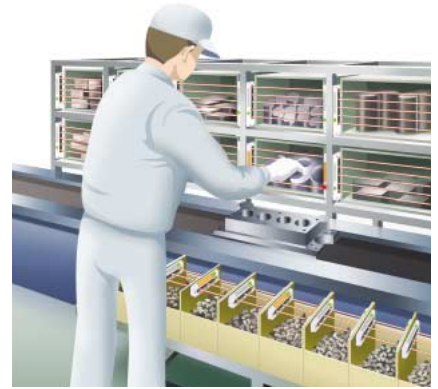

Standard Picking Sensor **NA1-PK5** series

Only 10mm thick, half the thickness of conventional models

Space savings now possible; ultra-thin design does not obstruct picking operations.



Cable can be freely arranged in any position

Incorporates a high-visibility job indicator

Bright, easy-to-see job indicators, 55mm 2.165in in length, have been incorporated into both the emitter and the receiver. Outstanding visibility has been made possible through the use of 8 orange LEDs.



Long sensing range 1.2m (3.937ft)

This is the 1.2m 3.937ft detection range model, suitable for large parts boxes.

Selectable illumination

The job indicator action can be selected for either 'constant illumination' or 'blinking'.

Two unit installations are possible

Sensor units can now be set to different light emission frequencies, in order to prevent mutual interference.

Two units can now be operated in a side-by-side configuration without interference, for problem-free detection over wider areas.

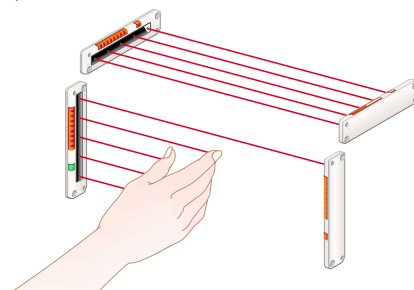

Selectable detection operation

Either of two different detection operations may be selected, in order to best suit the particular application. Sensor units can be set to detect the interruption of 1 or more beam channels, or can be set to detect only the interruption of 2 or more beam channels.

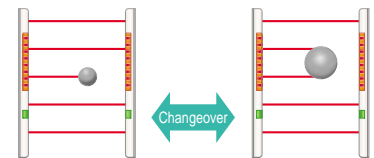

All opaque bodies with $\phi 35\text{mm}$ 1.378in or greater will be detected.

The accidental passage of small objects through the beam axis will not trigger detection, yet the operator's hands will always be accurately detected. This function is also useful when small objects regularly interrupt the beam axis.

Sensor protection brackets are available





Sensor protection brackets are now available (optional), to protect sensors from damage due to tools and other objects. The protection brackets have a black coating, which enhances the visual effectiveness of the job indicator.

Brackets are also available with a silver-colored coating.

NA1-PK3/NA1-PK5

ORDER GUIDE

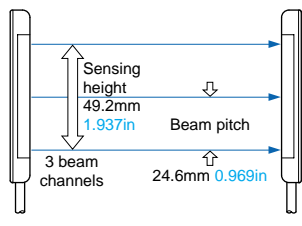
Sensors

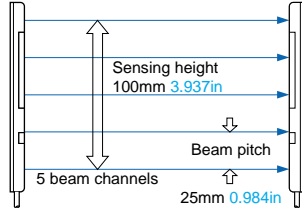
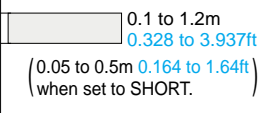
Type	Appearance	Sensing range (Note)	Model No.	Output
Compact-size			NA1-PK3	NPN open-collector transistor
			NA1-PK3-PN	PNP open-collector transistor
Standard			NA1-PK5	NPN open-collector transistor
			NA1-PK5-PN	PNP open-collector transistor

Note: The sensing range is the possible setting distance between the emitter and the receiver. **NA1-PK3(-PN)** can detect an object less than 30mm 1.181in away. **NA1-PK5(-PN)** can detect an object less than 100mm 3.937in (50mm 1.969in when set to SHORT) away.

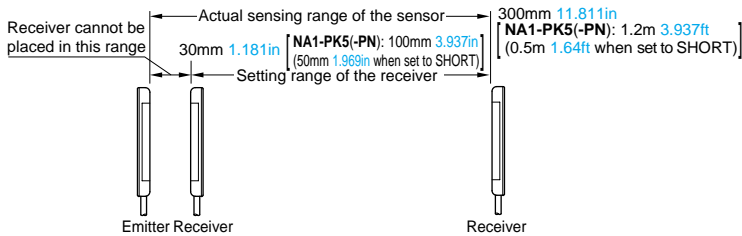

5m 16.404ft cable length type

For compact-size type, 5m 16.404ft cable length models are available. (Standard: 2m 6.562ft)
 Model No.: **NA1-PK3-C5** (NPN output), **NA1-PK3-PN-C5** (PNP output)

Pigtailed connector type

For compact-size type, pigtailed connector type is available. (Cable type is standard. Not available for 5m 16.404ft cable length type.)
 Model No.: **NA1-PK3-J** (NPN output), **NA1-PK3-PN-J** (PNP output)

Moreover, please order the mating cable separately.

• Mating cable (2 Nos. are required.)

Model No.	Description
CN-24-C2	4-core, cable length 2m 6.562ft
CN-24-C5	4-core, cable length 5m 16.404ft

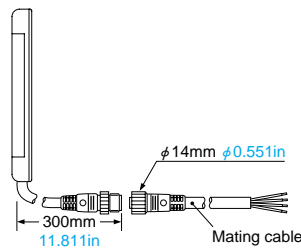

OPTIONS

Designation	Model No.	Description
Sensor protection bracket (For NA1-PK3 series)	MS-NA3-3	It protects the sensor body. Two black bracket set (Four M4 (length 15mm 0.591in) screws with washers, and four nuts are attached.)
Sensor mounting bracket (For NA1-PK5 series)	MS-NA1-1	Four bracket set (Four M4 (length 15mm 0.591in) screws with washers, eight nuts, four hooks, four spacers and eight M4 (length 18mm 0.709in) screws with washers are attached. (Spacers are not attached with MS-NA1-1.)
	MS-NA2-1	
Sensor protection bracket (For NA1-PK5 series)	MS-NA3	It protects the sensor body. Two silver bracket set (Four M4 (length 15mm 0.591in) screws with washers, and four nuts are attached.)
	MS-NA3-BK	It protects the sensor body. Two black bracket set (Four M4 (length 15mm 0.591in) screws with washers, and four nuts are attached.)
Slit mask (For NA1-PK5 series)	OS-NA1-5	The slit mask restrains the amount of beam emitted or received. (Seal type, 10 Nos. set)

Sensor protection brackets

- MS-NA3-3

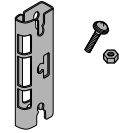

M4 screws with washers, and nuts are attached.

- MS-NA3
- MS-NA3-BK

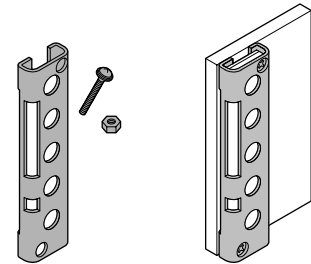

M4 screws with washers, and nuts are attached.

Sensor mounting brackets

- MS-NA1-1

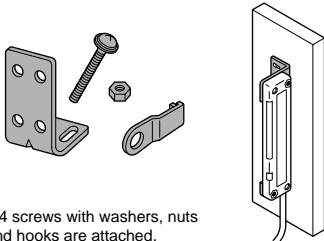

M4 screws with washers, nuts and hooks are attached.

- MS-NA2-1

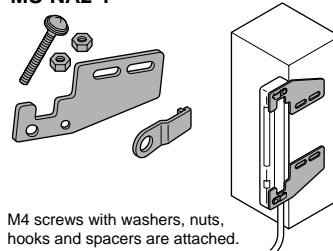

M4 screws with washers, nuts, hooks and spacers are attached.

Slit mask

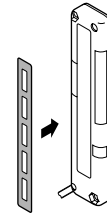

Since the slit mask is seal type, it can be used by sticking it to the detection surface.

Take care that the sensing range will be reduced when the slit mask is used.

Contact our office for details.

NA1-PK3/NA1-PK5

SPECIFICATIONS

Item	Type Model No.	Compact-size		Standard	
		NPN output NA1-PK3	PNP output NA1-PK3-PN	NPN output NA1-PK5	PNP output NA1-PK5-PN
Sensing height		49.2mm 1.937in		100mm 3.937in	
Sensing range (Note 1)		30 to 300mm 1.181 to 11.811in		0.1 to 1.2m 0.328 to 3.937ft (0.05 to 0.5m 0.164 to 1.64ft when set to SHORT)	
Beam pitch		24.6mm 0.969in		25mm 0.984in	
Number of beam channels		3 beam channels		5 beam channels	
Sensing object		φ29mm φ 1.142in or more opaque object		φ35mm φ 1.378in or more opaque object	
Supply voltage		12 to 24V DC ± 10%		Ripple P-P 10% or less	
Current consumption/Power consumption (Note 2)		Emitter: 30mA or less, Receiver: 50mA or less		Emitter: 0.5W or less, Receiver: 0.8W or less	Emitter: 0.6W or less, Receiver: 0.9W or less
Output		<NPN output type> NPN open-collector transistor • Maximum sink current: 100mA • Applied voltage: 30V DC or less (between output and 0V) • Residual voltage: 1V or less (at 100mA sink current) 0.4V or less (at 16mA sink current)		<PNP output type> PNP open-collector transistor • Maximum source current: 100mA • Applied voltage: 30V DC or less (between output and + V) • Residual voltage: 1V or less (at 100mA source current) 0.4V or less (at 16mA source current)	
	Output operation	ON or OFF when one or more beam channels are interrupted, selectable by operation mode switch		ON or OFF when one or more beam channels are interrupted/ON or OFF when two or more beam channels are interrupted, selectable by operation mode switch	
	Short-circuit protection	Incorporated			
Response time		10ms or less (when interference prevention is used: 30ms or less)		10ms or less (when the interference prevention is used, in Light state: 30ms or less, in Dark state: 13ms or less)	
Indicators	Emitter	Power indicator: Green LED (lights up when the power is ON) Job indicator: Orange LED (lights up when the job indicator input is Low)	Power indicator: Green LED (lights up when the power is ON) Job indicator: Orange LED (lights up when the job indicator input is High)	Power indicator: Green LED (lights up when the power is ON) Job indicator: Orange LED (lights up or blinks when the job indicator input is Low (PNP output type: High), lighting pattern is selected by operation mode switch)	
	Receiver	Operation indicator: Red LED (lights up when the output is ON) Stable incident beam indicator: Green LED (lights up when the all beams are stably received) Job indicator: Orange LED (lights up when the job indicator input is Low)	Operation indicator: Red LED (lights up when the output is ON) Stable incident beam indicator: Green LED (lights up when the all beams are stably received) Job indicator: Orange LED (lights up when the job indicator input is High)	Operation indicator: Red LED (lights up when one or more beams are interrupted, but lights up when two beams or more are interrupted in the double-beam-interruption mode) Stable incident beam indicator: Green LED (lights up when all beams are stably received) Job indicator: Orange LED (lights up or blinks when the job indicator input is Low (PNP output type: High), lighting pattern is selected by operation mode switch)	
Interference prevention function		Incorporated (Up to 3 units can be closely mounted.) (Note 3)		Incorporated (Up to 2 units can be closely mounted.)	
Environmental resistance	Pollution degree	3 (Industrial environment)			
	Protection	IP62 (IEC)			
	Ambient temperature	- 10 to +55°C +14 to +131°F (No dew condensation or icing allowed), Storage: - 20 to +70°C -4 to +158°F			
	Ambient humidity	35 to 85% RH, Storage: 35 to 85% RH			
	Ambient illuminance	Sunlight: 10,000ℓx at the light-receiving face, Incandescent light: 3,000ℓx at the light-receiving face			
	EMC	Emission: EN50081-2, Immunity: EN50082-2			
	Voltage withstandability	1,000V AC for one min. between all supply terminals connected together and enclosure			
	Insulation resistance	20MΩ, or more, with 250V DC megger between all supply terminals connected together and enclosure			
	Vibration resistance	10 to 150Hz frequency, 0.75mm 0.03in (5G max.) amplitude in X, Y and Z directions for two hours each			
Shock resistance	500m/s ² acceleration (50G approx.) in X, Y and Z directions for three times each				
Emitting element	Infrared LED (synchronized scanning system)				
Material	Enclosure: Heat-resistant ABS, Lens cover: Acrylic, Indicator cover: Acrylic				
Cable	0.2mm ² 4-core (emitter: 3-core) oil resistant cabtyre cable, 2m 6.562ft long		0.3mm ² 4-core (emitter: 3-core) oil resistant cabtyre cable, 2m 6.562ft long		
Cable extension	Extension up to total 100m 328.084ft is possible for both emitter and receiver with 0.3mm ² , or more, cable.				
Weight	Emitter: 50g 1.764oz approx., Receiver: 50g 1.764oz approx.		Emitter: 80g 2.822oz approx., Receiver: 85g 2.998oz approx.		

Notes: 1) The sensing range is the possible setting distance between the emitter and the receiver. **NA1-PK3(-PN)** can detect an object less than 30mm **1.181in** away. **NA1-PK5(-PN)** can detect an object less than 100mm **3.937in** (50mm **1.969in** when set to SHORT) away.

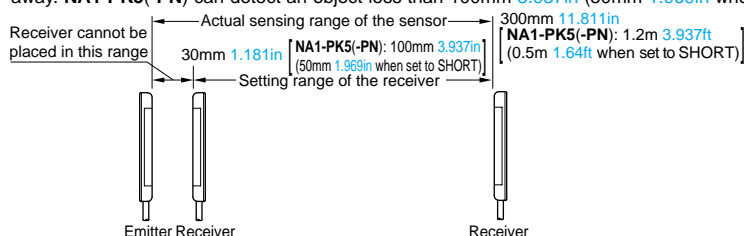

2) Obtain the current consumption of **NA1-PK5(-PN)** by the following equation.

Current consumption=Power consumption ÷ Supply voltage
(e.g.) When the supply voltage is 12V, the current consumption of the emitter is:
 $0.5W \div 12V = 0.042A = 42mA$

3) Only when the units are mounted closely together in the vertical position. If units are mounted horizontally, then this function will be effective for only 2 units.

I/O CIRCUIT AND WIRING DIAGRAMS

NA1-PK3(-J) NA1-PK5

NPN output type

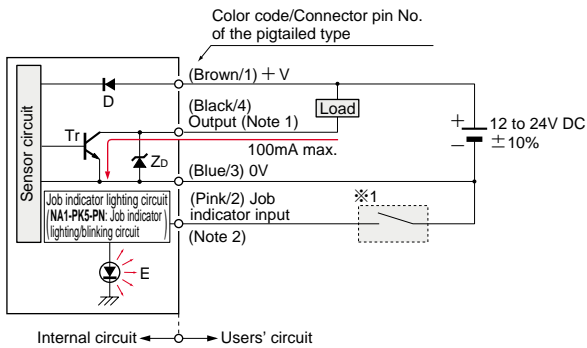

- Notes: 1) The output is not incorporated in the emitter.
 2) When the job indicator is used as a large size operation indicator, connect the job indicator input wire (pink) of the emitter and the receiver to the output wire (black) of the receiver.

Symbols... D : Reserve supply polarity protection diode
 Zb : Surge absorption zener diode
 Tr : NPN output transistor
 E : Job indicator (IND.)

※1

Non-contact voltage or NPN open-collector transistor

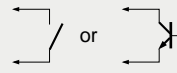

Low (0 to 2V): Lights up
 (NA1-PK5: Lights up or Blinks)
 High (5 to 30V, or open): Lights off

Connector pin position (Pigttailed connector type)

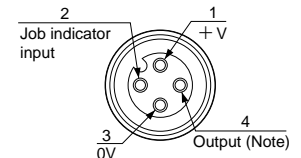

Note: No connection is required for the emitter.

NA1-PK3-PN(-J) NA1-PK5-PN

PNP output type

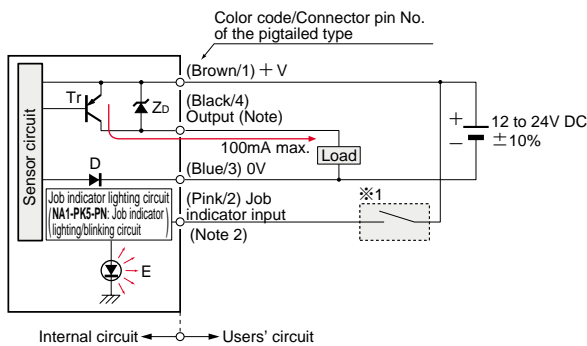

- Notes: 1) The output is not incorporated in the emitter.
 2) When the job indicator is used as a large size operation indicator, connect the job indicator input wire (pink) of the emitter and the receiver to the output wire (black) of the receiver.

Symbols... D : Reserve supply polarity protection diode
 Zb : Surge absorption zener diode
 Tr : PNP output transistor
 E : Job indicator (IND.)

※1

Non-contact voltage or PNP open-collector transistor

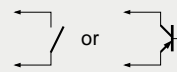

High (4 to 30V): Lights up
 (NA1-PK5-PN: Lights up or Blinks)
 Low (0 to 0.6V, or open): Lights off

Connector pin position (Pigttailed connector type)

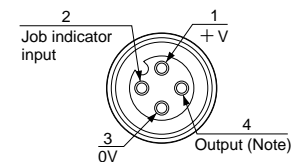

Note: No connection is required for the emitter.

NA1-PK3/NA1-PK5

SENSING CHARACTERISTICS (TYPICAL)

NA1-PK3 NA1-PK3-PN

Parallel deviation Vertical direction

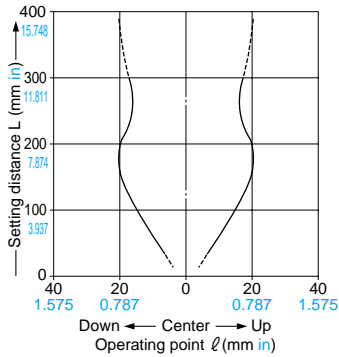
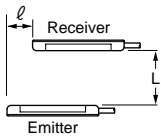

Horizontal direction

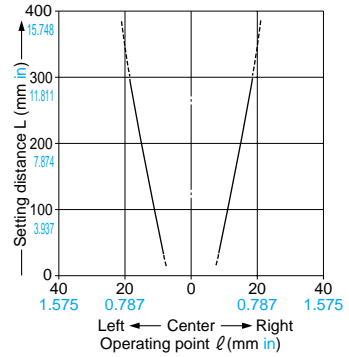
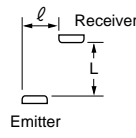

Angular deviation

Vertical direction emitter angular deviation

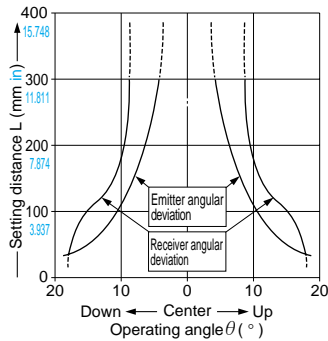
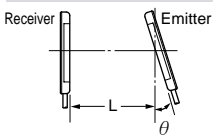

Vertical direction receiver angular deviation

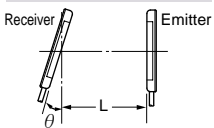

Horizontal direction emitter angular deviation

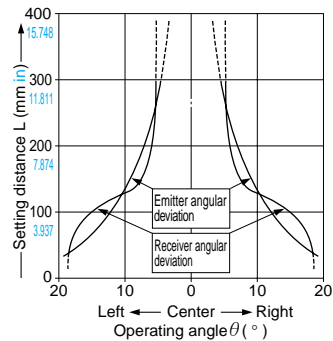
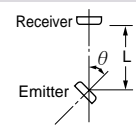

Horizontal direction receiver angular deviation

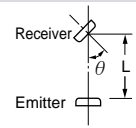

NA1-PK5 NA1-PK5-PN

Parallel deviation Vertical direction

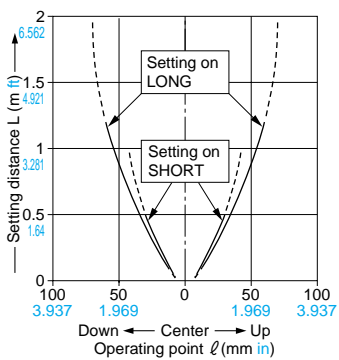
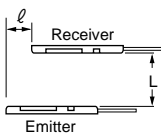

Horizontal direction

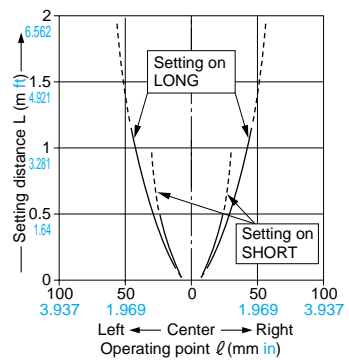
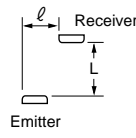

Angular deviation

Emitter angular deviation

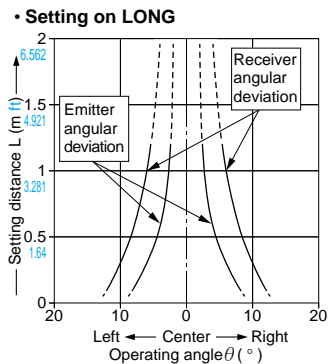
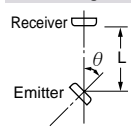

Receiver angular deviation

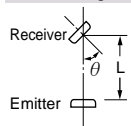

Setting on SHORT

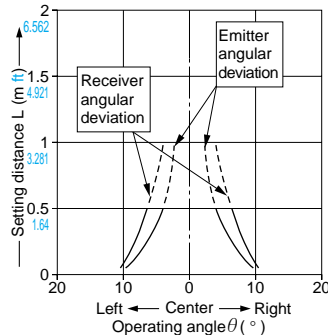

PRECAUTIONS FOR PROPER USE



- If this product is used as a sensing device for personnel protection, serious body injury or death could result.
- Never use this product as a sensing device with any press machine, shearing machine, roll grinding machine, forming machine, vulcanizer, or robot etc. for protection of a hand or a part of the body.
- This product does not include a self-checking circuit for safety functions necessary to allow its use as a safety device. Thus, a system failure or malfunction can result in either an energized or a de-energized output condition.
- When this product is used as a sensing device in the following applications and if a problem relating to 'law' or 'product liability' occurs, SUNX shall not be liable for the failure and for the damage or less.
 - 1) Use of this product installed to a machinery or a device as a sensing device to detect a hand or a part of the operator's body entering a dangerous area and stop the machinery or the device.
 - 2) Installation of this product to a protection device for preventing to enter a dangerous area and use of this as a sensing device which detects a hand or a part of the operator's body and open/close the door or window.
 - 3) Use of this product as a sensing device for personnel protection (including interlock).
- For sensing devices to be used as safety devices for press machines or for personnel protection, use products which meet standards, such as OSHA, ANSI or IEC etc., for personnel protection applicable in each region or country.
- In case of using as a safety device for press machine, use a product approved by the Ministry of Labor in Japan.

Mounting

- Use M4 screws with washers and M4 nuts. The tightening torque should be 0.5N·m or less.
(Please arrange the screws and nuts separately.)

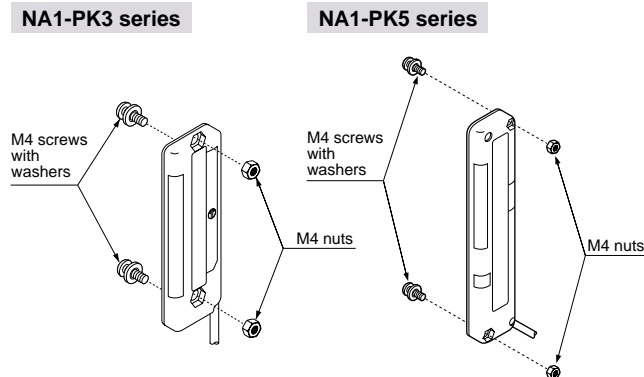

Orientation

- The emitter and the receiver must face each other correctly. If they are set upside down, the sensor does not work.

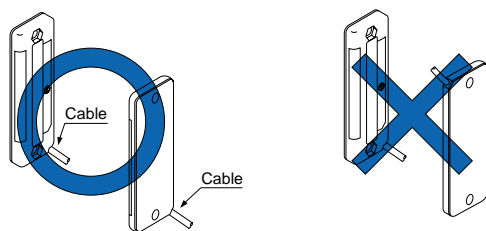

LONG/SHORT selection switch (Incorporated on the emitter, NA1-PK5 series only)

- Select the switch setting according to the setting distance between the emitter and the receiver as given below.
(The switches must be set with the power supply off.
(The operation mode does not change if the switch setting is changed with the power supplied.)

Setting distance	Operation mode switch
0.05 to 0.5m 0.164 to 1.64ft	LONG SHORT
0.5 to 1.2m 1.64 to 3.937ft	LONG SHORT

Wiring

- Make sure to carry out the wiring and operation of the selection switch in the power supply off condition.
- Take care that wrong wiring may damage the sensor.
- Verify that the supply voltage variation is within the rating.
- If power is supplied from a commercial switching regulator, ensure that the frame ground (F.G.) terminal of the power supply is connected to an actual ground.
- In case noise generating equipment (switching regulator, inverter motor, etc.) is used in the vicinity of the sensor, connect the frame ground (F.G.) terminal of the equipment to an actual ground.
- Extension up to total 100m 328.084ft is possible with 0.3mm², or more, cable for both emitter and receiver. However, in order to reduce noise, make the wiring as short as possible.
- Do not run the wires together with high-voltage lines or power lines or put them in the same raceway. This can cause malfunction due to induction.
- Make sure to use an isolation transformer for the DC power supply. If an auto-transformer (single winding transformer) is used, this product or the power supply may get damaged.
- In case a surge is generated in the used power supply, connect a surge absorber to the supply and absorb the surge.

Others

- Do not use during the initial transient time (0.5 sec.) after the power supply is switched on.
- Take care that the sensor is not directly exposed to fluorescent light from a rapid-starter lamp or a high frequency lighting device, as it may affect the sensing performance.
- Avoid dust, dirt, and steam.
- Take care that the product does not come in direct contact with water, oil, grease or organic solvents, such as, thinner, etc.
- This sensor is suitable for indoor use only.

Job indicator operation selection (NA1-PK5 series only)

- Lighting/Blinking is selected by the operation mode switch on the emitter and the receiver.
(The switches must be set with the power supply off.
(The operation mode does not change if the switch setting is changed with the power supplied.)

	Operation mode switch	
	Emitter	Receiver
Lighting	LIGHT FLASH	LIGHT FLASH
Blinking	LIGHT FLASH	LIGHT FLASH

NA1-PK3/NA1-PK5

DIMENSIONS (Unit: mm in)

**NA1-PK3(-PN)
NA1-PK3(-PN)-C5** Sensor

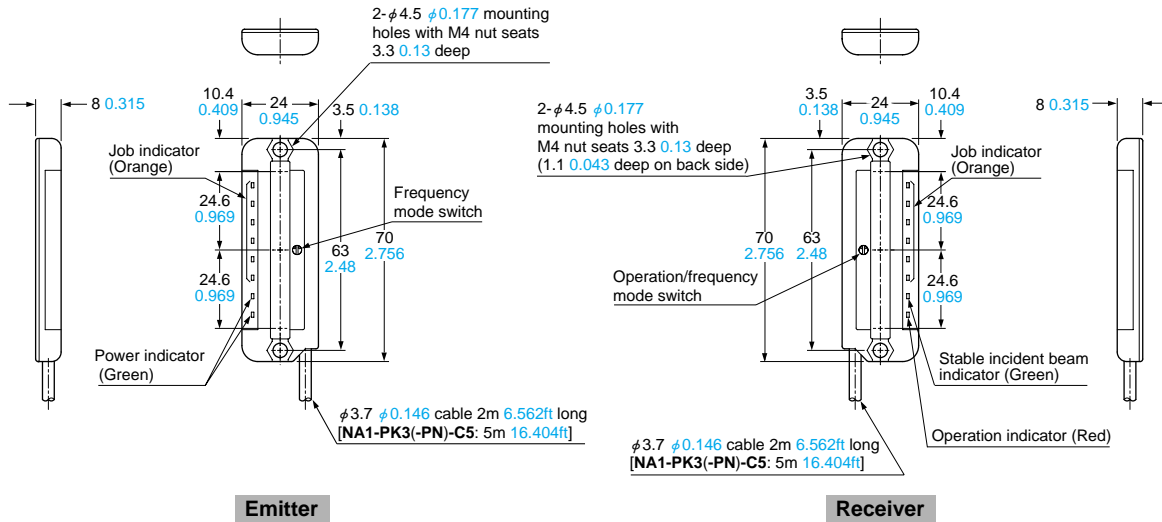

MS-NA3-3 Sensor protection bracket for NA1-PK3 series (Optional)

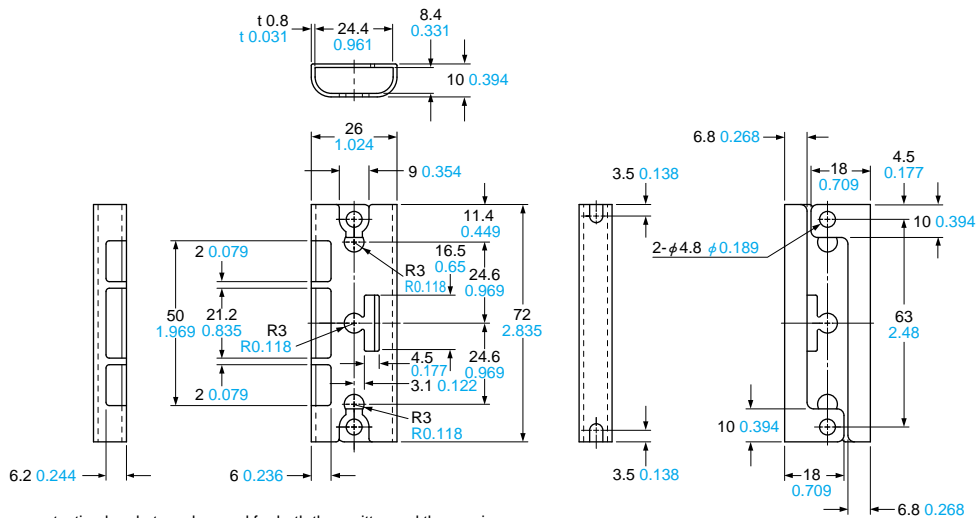

Note: The sensor protection bracket can be used for both the emitter and the receiver.

Material: Cold rolled carbon steel (SPCC) (Black chromate)

Two bracket set

[Four M4 (length 15mm 0.591in) screws with washers and four nuts are attached.]

DIMENSIONS (Unit: mm in)

NA1-PK5(-PN) Sensor

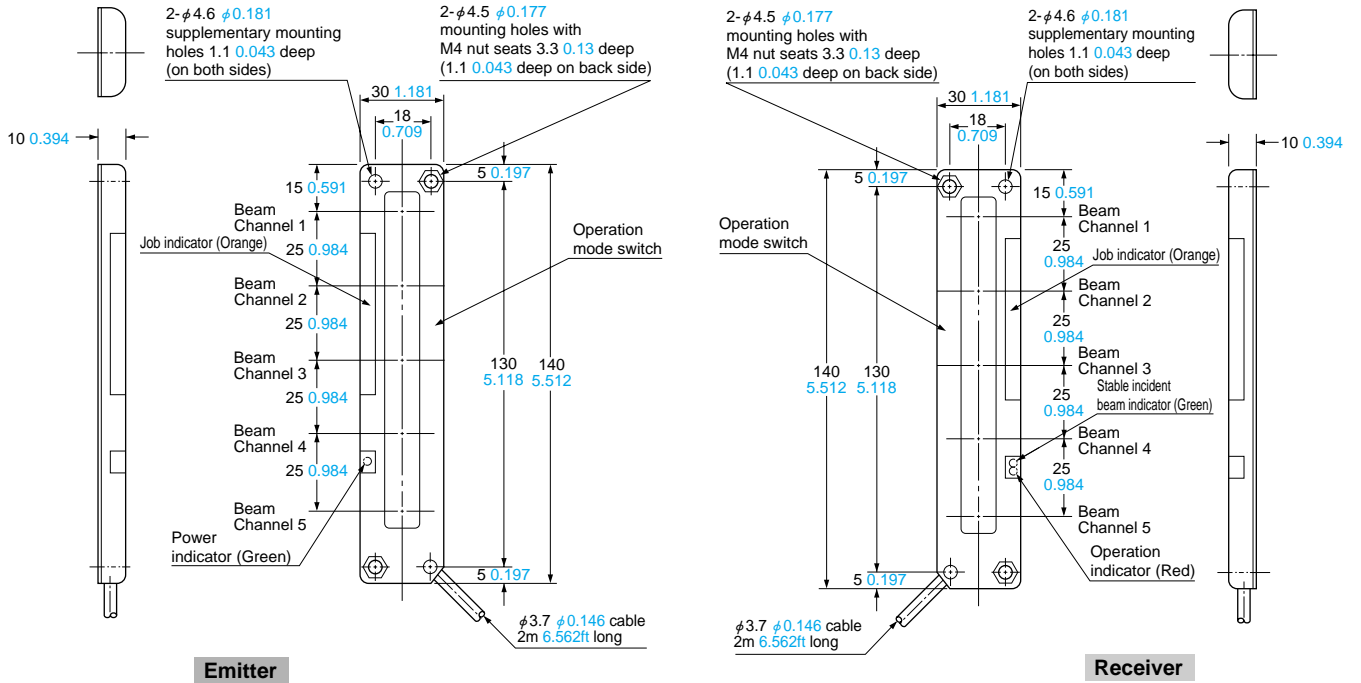

MS-NA1-1 Sensor mounting bracket for NA1-PK5 series (Optional)

Assembly dimensions Mounting drawing with the receiver

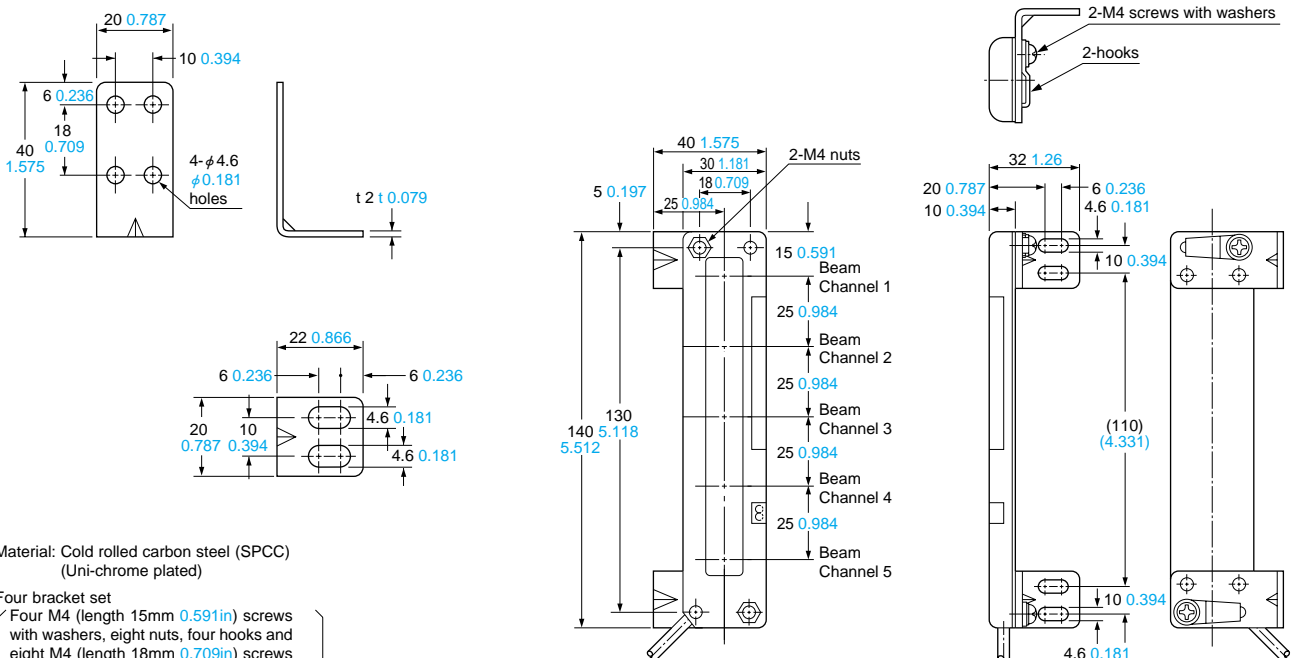

DIMENSIONS (Unit: mm in)

MS-NA2-1 Sensor mounting bracket for NA1-PK5 series (Optional)

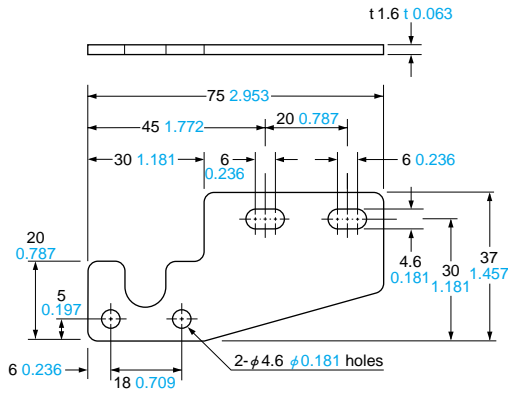

Material: Cold rolled carbon steel (SPCC)
(Uni-chrome plated)

Four bracket set
(Four M4 (length 15mm 0.591in) screws with washers, eight nuts, four hooks, four spacers and eight M4 (length 18mm 0.709in) screws with washers are attached.)

Assembly dimensions Mounting drawing with the receiver

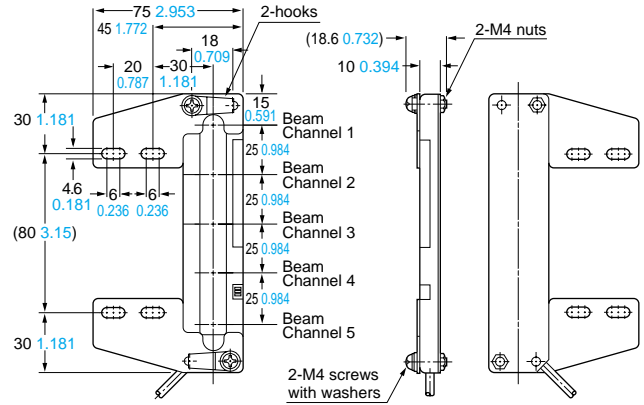

MS-NA3 MS-NA3-BK Sensor protection bracket for NA1-PK5 series (Optional)

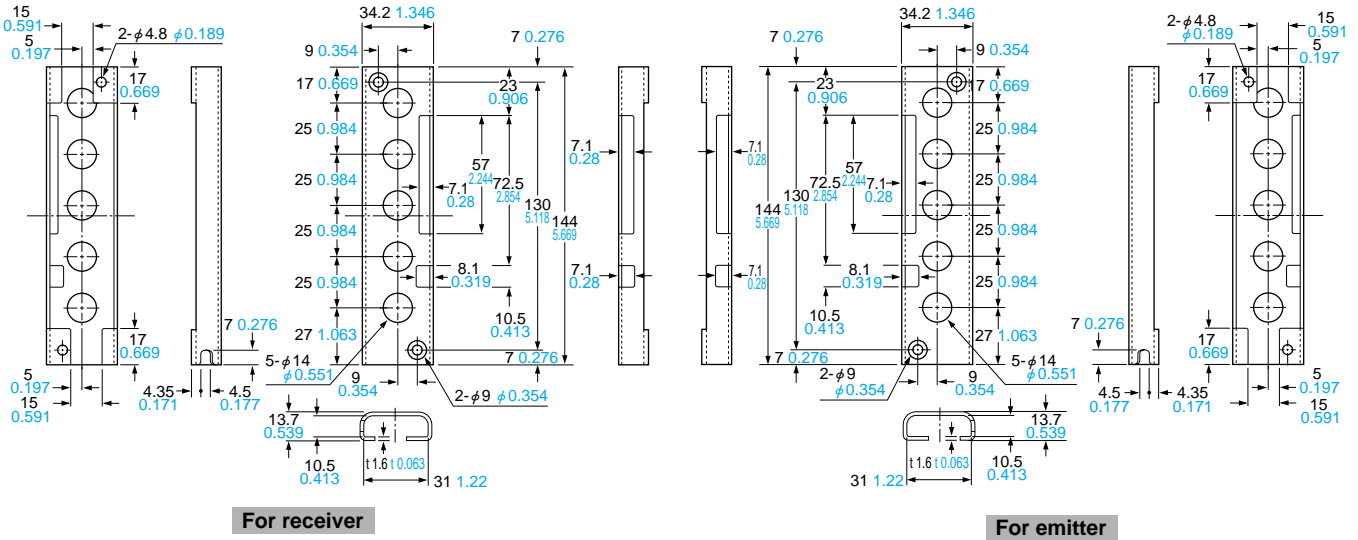

Material: Cold rolled carbon steel (SPCC)
(MS-NA3: Chrome plated, MS-NA3-BK: Black chromate)

Two bracket set
(Four M4 (length 15mm 0.591in) screws with washers, and four nuts are attached.)

All information is subject to change without prior notice.



<http://www.sunx.co.jp/>

SUNX Limited

2431-1 Ushiyama-cho, Kasugai-shi, Aichi,
486-0901, Japan
Phone: +81-(0)568-33-7211
FAX: +81-(0)568-33-2631

Overseas Sales Dept.

Phone: +81-(0)568-33-7861
FAX: +81-(0)568-33-8591

AUDIN

Composants & systèmes d'automatisme
8 avenue de la malle - 51370 St Brice Courcelles - France
Tel. +33(0)326042021 • Fax +33(0)326042820
<http://www.audin.fr> • e-mail info@audin.fr