

SUNX

NEW DIGITAL FIBER SENSOR

FX-500SERIES

CE
Conforming to EMC Directive

**At the industry's
leading edge**

FX-SERIES HIGH END MODEL



40th
Anniversary
MODEL

Stability

Industry leading stability

Decrease the variation among fiber sensors

High stability!

“Why are the values different even for the same detection?” “If we try to forcibly unify all the display values of incident light intensity, we will not be able to read the actual changes.”

SUNX focuses on the variation among fiber sensors and aims for absolute digitalization.

When the **FX-500** series is used together with our super quality fiber, the incident light intensity variation among units is decreased to only 1/4 of that of conventional models.

By being close to absolute values instead of modified digital values, changes in detection that could not be found in the past can now be monitored.

Super quality fiber

FX-500 series

Threshold value Incident light intensity

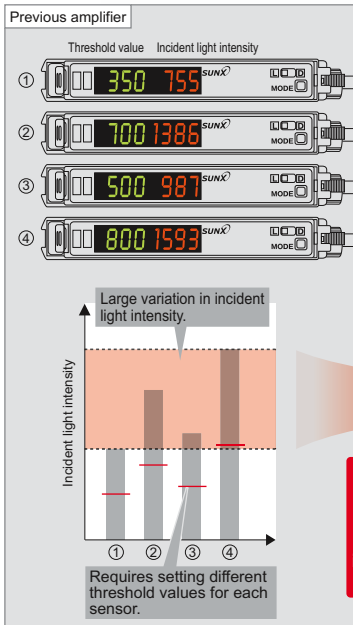

Digital control is essentially achieved

Stability of the incident light intensity is improved by 4 times*. Values of incident light intensity stay close together even after replacing an amplifier.

* Using a small diameter fiber (fiber core ø0.5 mm ø0.020 in). If using a standard fiber (fiber core ø1.0 mm ø0.039 in), the variation will be double of that of conventional models.

1/4 incident light intensity variation [from previous]

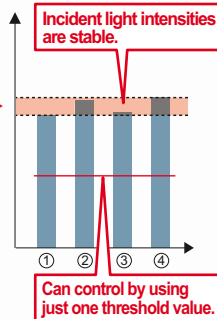

Specifying just one value in an operation manual is possible

In the case where multiple fiber sensors are installed under the same operating conditions, the incident light intensities are nearly identical to each other, allowing for the specification of one threshold across all sensors.

Maintenance is easy on stabilized fiber sensors

Because the incident light intensity is stable, the same threshold value can be used even when an amplifier is replaced. Also, copying of settings is easy when used together with optical communication.

Stability in incident light intensity and confidence in beam adjustment

When setting up fiber sensors in a row in the same layout, all incident light intensities will display nearly identical values once beams are aligned. This helps to raise installation precision and prevent trouble from occurring before equipment is turned on.

Improved fiber coupling efficiency and suppressed variation among units

In each unit we have accurately aligned the central axis of the fiber with the central axis of the emitted light, which creates a high coupling efficiency that helps to reduce variation among units.

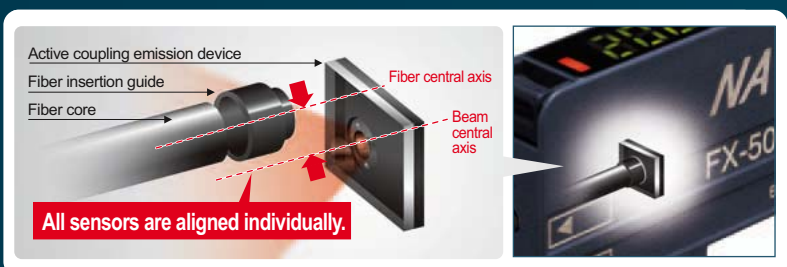

* Illustration is an approximation

"Super quality fiber" with stable emission amount

"Stabilized incident light intensities" even in multiple units

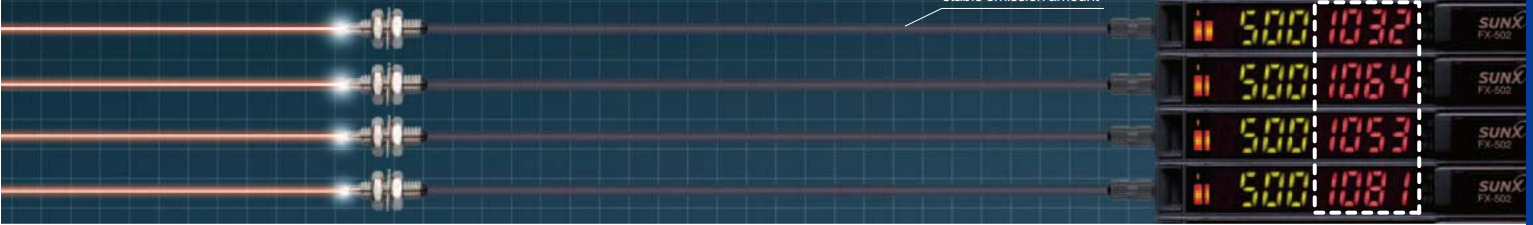

A quality that surpassed standard fiber

Introducing super quality fiber



New fibers developed using a new manufacturing method adopted by our own factory along with a persistent quality control system

The basic performance of a standard fiber is greatly enhanced!

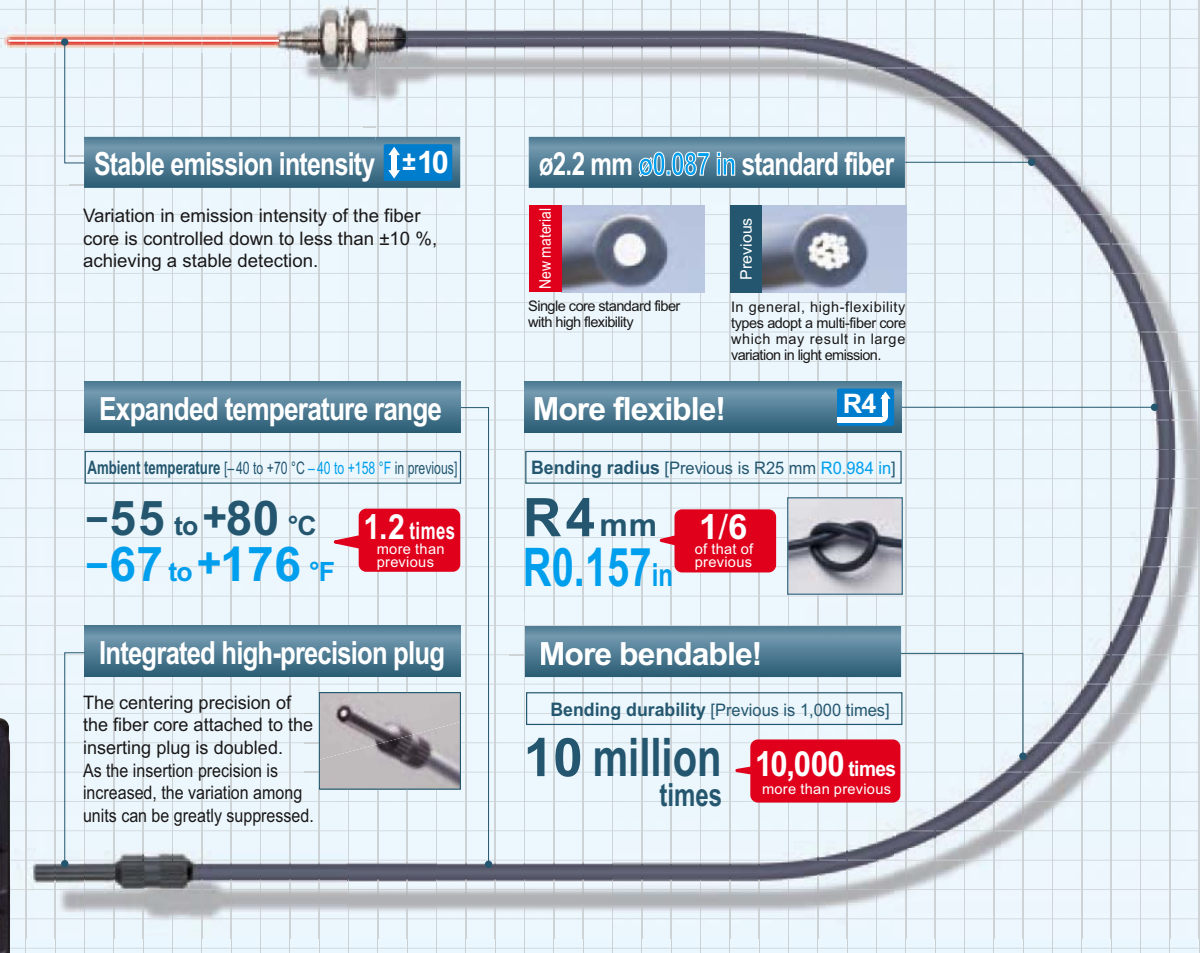

$\updownarrow \pm 10$

Variation in emission intensity is down to less than $\pm 10\%$

Under our new manufacturing method and quality control system, we have developed fiber heads that have a stabilized light emission. When used with the FX-500 amplifier, a complete digital control is essentially achieved.

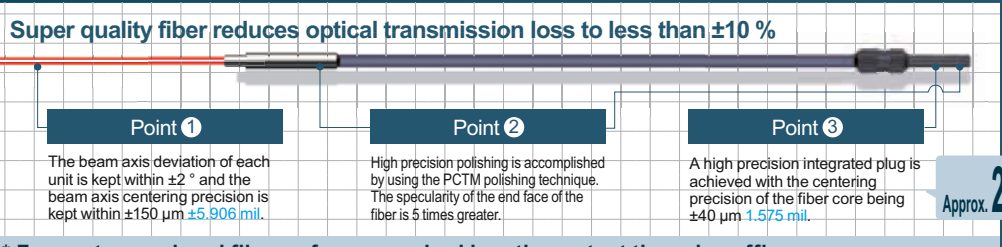

* For custom-ordered fibers of your required length, contact the sales office near you.

07/2010

Speed & Distance

Industry leading sensing performance

Ultra high-speed & Ultra long range detection

The exclusive detection IC combined with the high intensity beam emitted from the active coupling emission device provides the capability of offering high-speed response time over a longer sensing range, opening up new possibilities for fiber sensor detection.

Max. 25 μ s response time

FX-500 with its ultra high response time improves productivity.



Performing minute object detection when using a small diameter fiber is now possible with a high response time and longer sensing range.

Hyper HYPR mode incorporated

FX-500 in combination with small diameter fibers which can handle challenging detections, allows super long sensing range.

Max. 5.6 times! (Note)
longer than the previous model

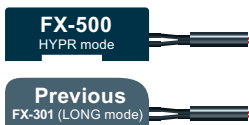

Note: When using FD-NFM2.

Long sensing range with small diameter fibers

Small diameter fibers with a compact head can perform long range and stable detection for minute objects.

Long sensing range even in high speed mode

A high speed response time of 25 μ s, which is 2.6 times more than previous, and a long sensing range are now possible in high speed mode.

Satisfying both high speed and long range

The active coupling emission device efficiently focuses the beam through small diameter fibers

A super fine optical lens and emitting element are combined into one device enabling the beam emitted from the emitting element to be focused directly into the fiber. Coupling efficiency is therefore increased by 50 % of that of standard fiber (core \varnothing 1 mm \varnothing 0.039 in). In particular, the small diameter fibers (core \varnothing 0.5 mm \varnothing 0.020 in) see a dramatic increase in light intensity, making challenging detections possible.

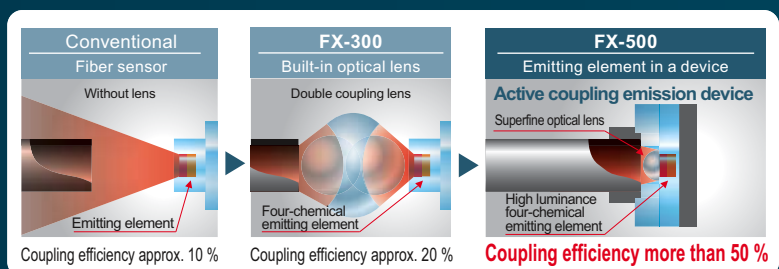

Coupling efficiency \approx (light intensity directed into the fiber / emission intensity of active coupling emission device) \times 100 * Illustration is an image.



Sharp detection with suppressed hysteresis

A different accuracy!

FX-500 with its accurate detection catches fractional difference in light intensity, fulfilling high precision and low-hysteresis applications.

H-02 mode

Long range detection of small objects with small difference in light intensity

FX-500 series achieves a long sensing range by its suppressed hysteresis and high intensity beam. Detection of minute objects over a long range is now more accurate compared to the past.

Comparison image of optimal sensing region

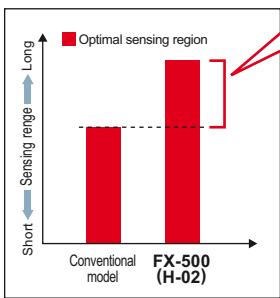

Long range detection of a glass target is now possible due to the ability of the sensor to detect small changes in light intensity.

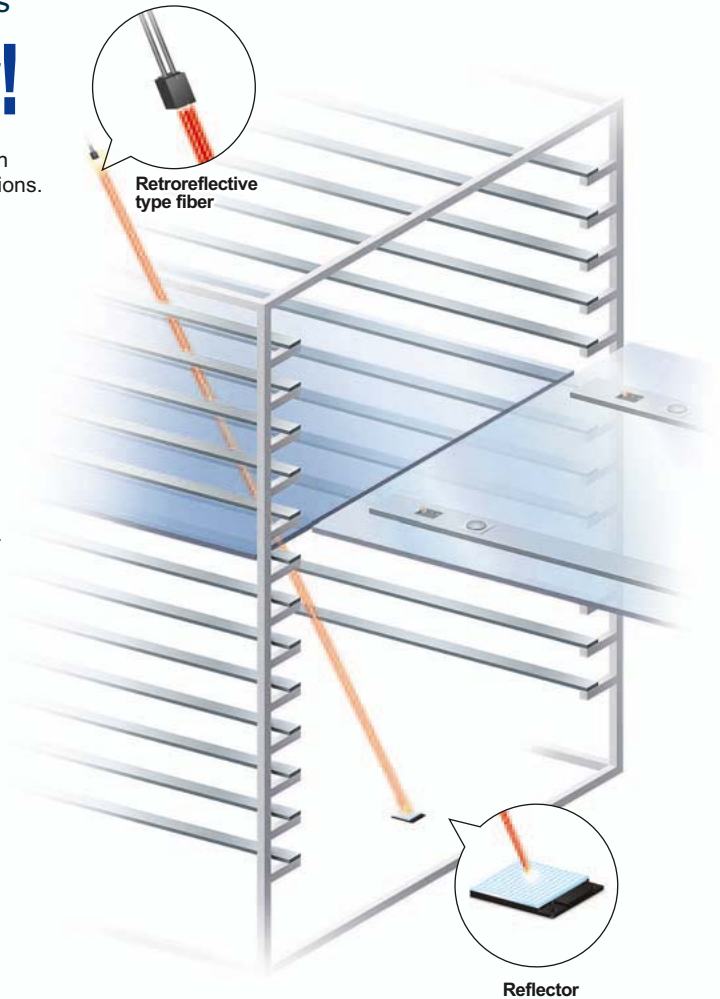

H-01 mode

Highly accurate detection while avoiding saturation

Even when the received light becomes saturated, the FX-500 series cuts down hysteresis to the utmost limit in order to produce the optimal margin for detection.

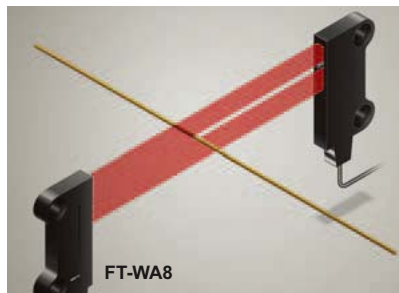

Comparison image of optimal sensing region

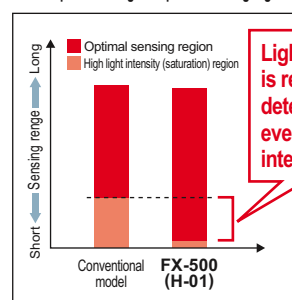

Light saturated region is reduced, and detection is possible even under high light intensity.

Three hysteresis modes

Hysteresis is the difference in incident light intensity at the points when the output turns ON and when the output turns OFF. Hysteresis was originally intended to be used as a measure against vibrations, but SUNX provides three hysteresis modes to suit the need of fiber sensors.

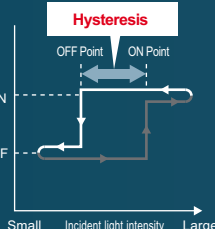

Mode table			
Mode	Hysteresis amount	Light intensity	Description
H-01	Minimal	Small	Sharp detection with high accuracy is possible in this mode. Optimal for minute object detection where light saturates easily.
H-02	Small	Large	Initial setting mode. Accurate detection such as long range detection of a large glass substrate is possible.
H-03	Large	Large	A mode used for chattering prevention. Works in adverse environments such as vibration or dirt.

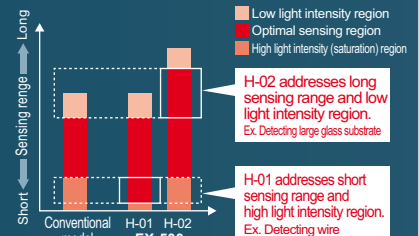

H-02 addresses long sensing range and low light intensity region. Ex. Detecting large glass substrate

H-01 addresses short sensing range and high light intensity region. Ex. Detecting wire

Class leading form and operability

New form!

Flat display with wide viewing angle

The large and high-contrast 7-segment display of high luminance provides clear visibility from a wide angle of view.

Clearly visible even from sideways

Compact cover does not get in the way
Reduced to **1/3** of that of previous

R23 mm
R0.906 in



Streamlined fiber clutch

While the conventional fiber installation is done after opening up the cover, the **FX-500** series adopts a guard structure, eliminating the cover so that the fiber installation can be done in one step.

MODE NAVI + Direct setting

MODE NAVI uses three indicators and a dual display to show the amplifier's basic operations. The current operation mode can be confirmed at a glance, so even a first time user can easily operate the amplifier.

Streamlined fiber clutch

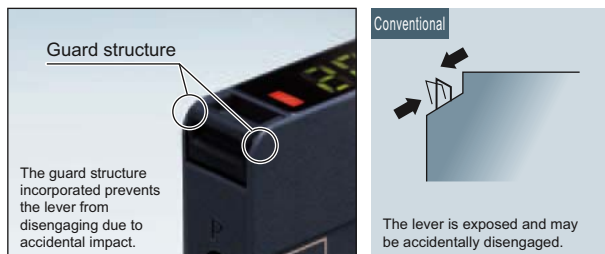
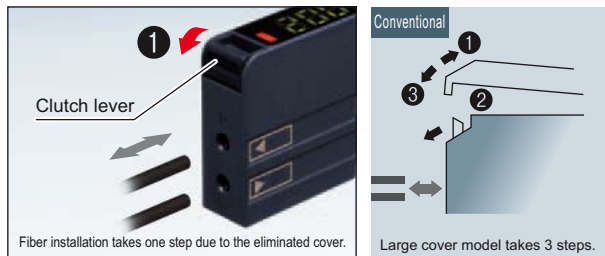

NAVI display (lights out during RUN mode)

L/D

Switches output operation.
L: Light-ON D: Dark-ON

CUST

Allows direct change by selecting one of the setting of response time / hysteresis / emitting power. (Initial setting: response time)

PRO

Allows the selection of advanced functions such as timer, copy, and memory functions.



Direct setting



A variety of functions at the industry's leading edge

Resolves variation in incident light intensity display

Display adjustment setting

Even if there is no problem in detection, the variation in display may make it difficult for an operator to verify proper operation. By using the display adjustment setting, random values can be adjusted, and the visual variation can be resolved to help define proper operation in an operation manual.

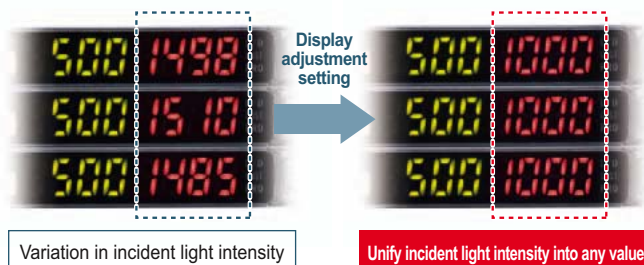

Stable detection over long and short periods

Stabilized emission intensity

The "four-chemical emitting element" was first incorporated in the conventional model **FX-300** to maintain a stable level of light emission and has now become an industry standard. **FX-500** series continues to adopt the same emitting element as well as the "APC (Auto Power Control) circuit" which improves stability in short periods such as when the power is turned on.

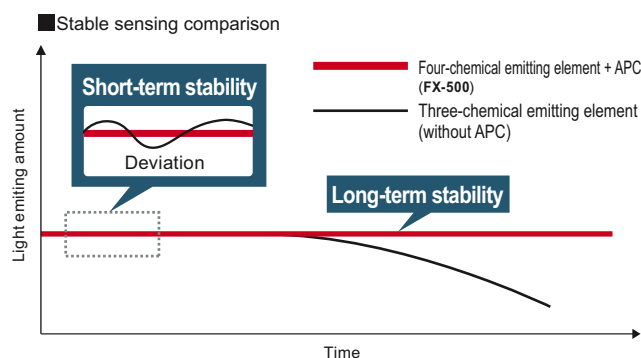

Saves maintenance time

Threshold tracking function

This function seeks changes in the light emitting amount resulting from changes in the environment over long periods (such as dust levels), so that the incident light intensity can be checked at desired intervals and the threshold values can be reset automatically.

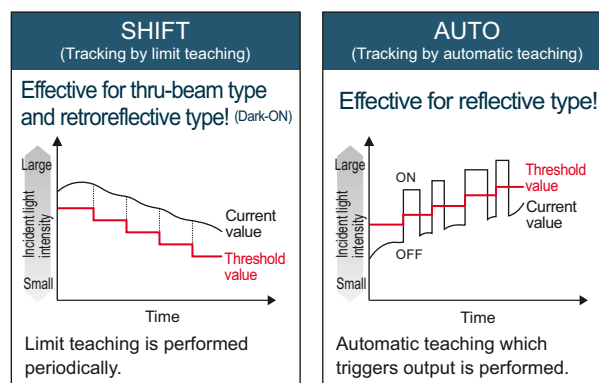

Suitable for preventative maintenance

Self-diagnosis output

FX-502(P) / 505(P)-C2 can set Output 2 as self-diagnosis output. When Output 1's threshold value teaching is carried out, Output 2 is set concurrently with the setting randomly shifted by the amount of surplus of threshold value.

■ Detect drops in light intensity (e.g. used in dusty environment)



Self-diagnosis can be used with the threshold tracking function for added effectiveness.

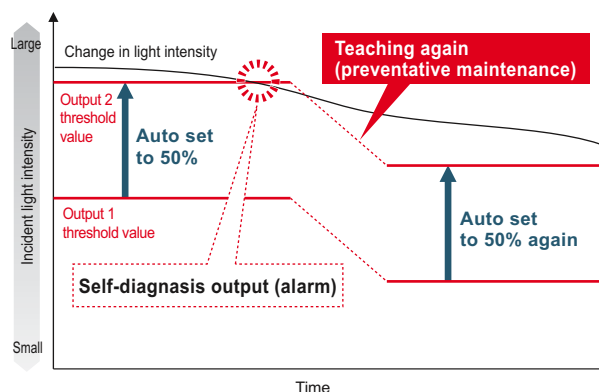

A variety of functions at the industry's leading edge

Stable detection while being eco-friendly

Emission power & gain setting



For cases when the incident light intensity saturates the receiver, the light intensity can be attenuated to the optimal level by AUTO without changing the response time. This allows for stable detection while maintaining an optimal S/N ratio and saves energy by controlling the emitting electric current.

■ Detecting a transparent sheet

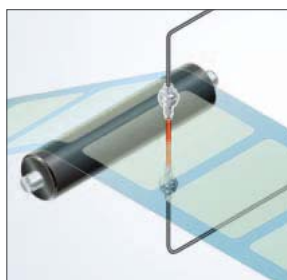

Object present

Object absent

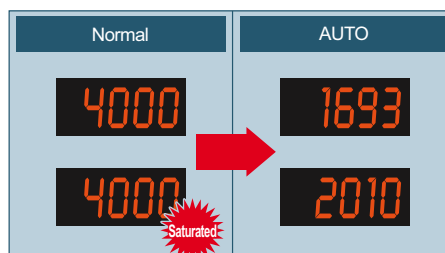

Auto mode (AUTO) and 3-level manual mode (3 levels: H / M / L [adjustable]) are incorporated.

Built-in logic functions

No PLC necessary saving material and programming costs

■ Logical calculation functions

Three logical calculations (AND, OR, XOR), are selectable using Output 1 of multiple FX-500 series amplifiers.

A PLC is not required which helps to reduce material and programming and costs.

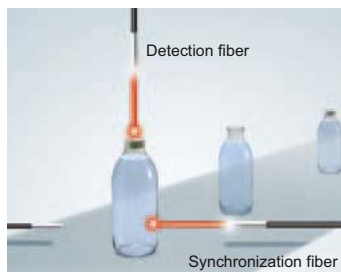

■ Calculation of two neighboring amplifiers

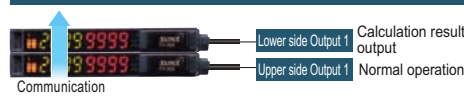

■ Calculation of two outputs in one amplifier FX-502(P) / 505(P)-C2

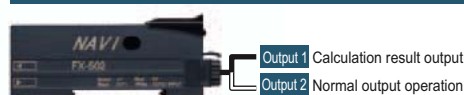

■ Calculation of one amplifier and external input FX-502(P) / 505(P)-C2

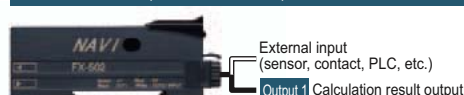

■ Equipped with 5 types timers

A wide variety of timer control operations can be carried out by these fiber sensors alone.

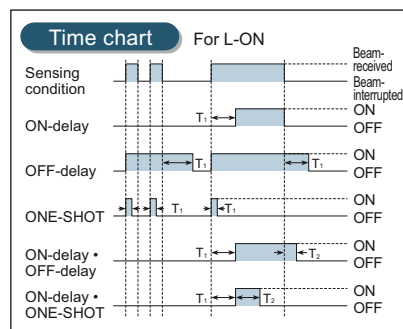

Timer period: 0.05 ms to 32 s
Output 1 has ON-delay + OFF-delay and ON-delay + ONE-SHOT timers.

Analog control is possible

Analog output cable type FX-505(P)-C2

A 4 to 20 mA analog output represents the digital value of incident light intensity

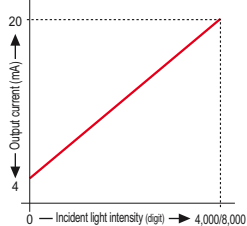

■ Edge tracking of film or sheet

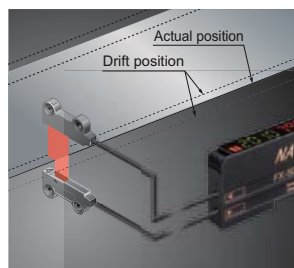

Drifting path can be tracked as the light intensity changes.

8 data banks

Smooth setup changes

The number of data banks used for saving the setup conditions of the amplifier is increased to eight. Setup conditions can be saved and loaded to make setup changes easy at worksite that manufactures multiple models.

External input

Remote control improves work efficiency FX-502(P) / 505(P)-C2

Work efficiency can be improved by operating via a PLC output or other external signal.

■ Functions operable by external input

Full-auto / Limit / 2-point teaching	Display adjustment setting
Data bank load / save	Logical calculation (self-unit only)
Emission halt	Copying function lock (self-unit only)



Selectable interference prevention

In addition to the automatic interference prevention function which is enabled through the optical communication of cascade connected amplifiers, an alternate frequency interference prevention function is also incorporated. So even for layouts where optical communication cannot be carried out, switching of emission frequencies allows interference prevention.

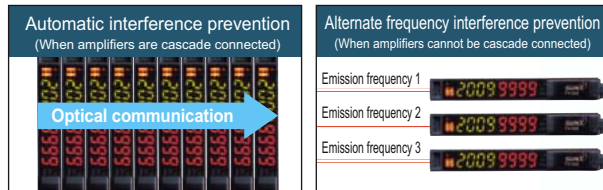

* Refer to specifications for details of number of sensors allowed in interference prevention.

An optical communication function allows sensors to be adjusted simultaneously

The optical communication function allows the data that is currently set to be copied and saved all at once for all amplifiers connected together from the right side. This greatly reduces troublesome setup tasks and makes setup much smoother.



No need to specify a main unit or sub unit

All FX-500 amplifiers can be used as either a main unit or a sub unit. Just use a main cable or a sub cable to distinguish the two. This reduces the costs of inventory management.

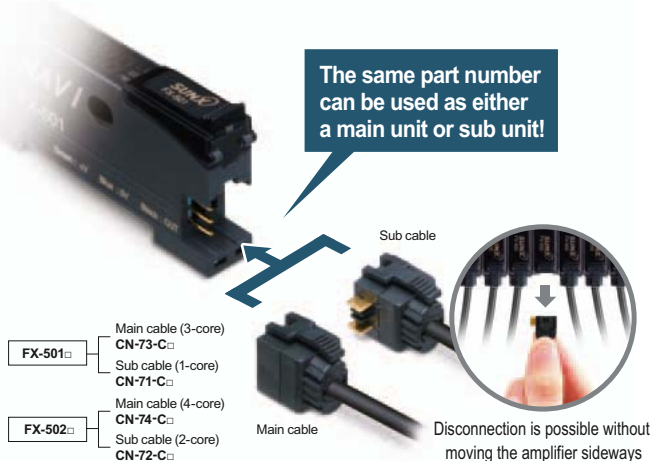

Wire-saving, space-saving

The quick-connection cables enable reduction in wiring. The connections and man-hours required for the relay terminal block setup can be reduced and valuable space is saved.

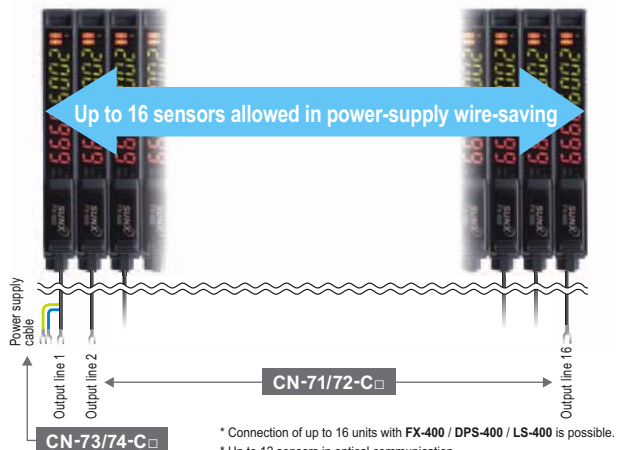

PRO mode functions



PRO1	Response time setting
	Timer setting
	Hysteresis setting
	Shift amount setting
	Emission power setting
PRO2	Timer range setting
	Teaching lock setting
	Digital display item setting
	Digital display turning on setting
	ECO setting
PRO3	Period hold setting
	Data bank loading setting
	Data bank saving setting
	Back up setting
PRO4	Input / output setting ^{*1}
	Copy setting
	Copy action setting
	Copy lock setting
	Communication protocol setting
	External input setting ^{*2}

PRO5	Code setting	
	Display adjustment setting	
	Reset setting	
	CUSTOM setting	
	Interference prevention setting	
PRO6	Sensing output mode	Normal mode
		Window comparator mode ^{*3}
		Rising differential mode
		Trailing differential mode
		Hysteresis mode
		Forced ON output mode
		Forced OFF output mode
		Self-diagnosis output mode ^{*4}
Answer back output mode ^{*5}		
PRO7	Setting of threshold value tracking	Logical operation setting ^{*6}
		Setting of threshold tracking
		Sensing output setting
		Storage cycle setting
		Algorithm setting

*1: FX-502(P) only *2: FX-502(P) and FX-505(P)-C2 only *3: Output 1 only
 *4: Output 2 only of FX-502(P) and FX-505(P)-C2 *5: Output 2 only of FX-505(P)-C2
 *6: FX-501(P) can do a part of operations.

ORDER GUIDE

Amplifiers Quick-connection cable is not supplied with **FX-501(P)** and **FX-502(P)**. Please order it separately.

Type	Appearance	Model No.	Emitting element	Output	External input
Standard type		FX-501	Red LED	NPN open-collector transistor	_____
		FX-501P		PNP open-collector transistor	
2-output type		FX-502		NPN open-collector transistor 2 outputs	Incorporated Switchable with Output 2
		FX-502P		PNP open-collector transistor 2 outputs	
Cable type		FX-505-C2		NPN open-collector transistor 2 outputs analog output	Incorporated
		FX-505P-C2		PNP open-collector transistor 2 outputs analog output	

Quick-connection cables

For FX-501(P) Quick-connection cable is not supplied with the amplifier. Please order it separately.

Type	Model No.	Description	
Main cable (3-core)	CN-73-C1	Length: 1 m 3.281 ft	0.15 mm ² 3-core cabtyre cable, with connector on one end Cable outer diameter: ø3.0 mm ø0.118 in
	CN-73-C2	Length: 2 m 6.562 ft	
	CN-73-C5	Length: 5 m 16.404 ft	
Sub cable (1-core)	CN-71-C1	Length: 1 m 3.281 ft	0.15 mm ² 1-core cabtyre cable, with connector on one end Cable outer diameter: ø3.0 mm ø0.118 in
	CN-71-C2	Length: 2 m 6.562 ft	
	CN-71-C5	Length: 5 m 16.404 ft	

Main cable

- **CN-73-C**□

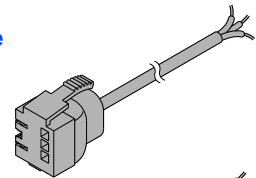

Sub cable

- **CN-71-C**□

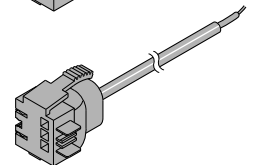

For FX-502(P) Quick-connection cable is not supplied with the amplifier. Please order it separately.

Type	Model No.	Description	
Main cable (4-core)	CN-74-C1	Length: 1 m 3.281 ft	0.15 mm ² 4-core cabtyre cable, with connector on one end Cable outer diameter: ø3.0 mm ø0.118 in
	CN-74-C2	Length: 2 m 6.562 ft	
	CN-74-C5	Length: 5 m 16.404 ft	
Sub cable (2-core)	CN-72-C1	Length: 1 m 3.281 ft	0.15 mm ² 2-core cabtyre cable, with connector on one end Cable outer diameter: ø3.0 mm ø0.118 in
	CN-72-C2	Length: 2 m 6.562 ft	
	CN-72-C5	Length: 5 m 16.404 ft	

Main cable

- **CN-74-C**□

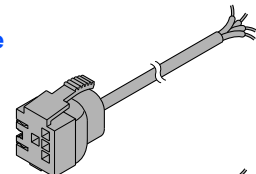

Sub cable

- **CN-72-C**□

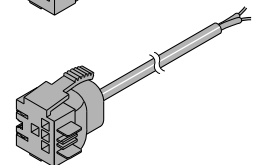

End plates End plates are not supplied with the amplifier. Please order them separately when the amplifiers are mounted in cascade.

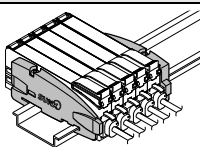
Appearance	Model No.	Description
	MS-DIN-E	When cascading multiple amplifiers, or when it moves depending on the way it is installed on a DIN rail, these end plates clamp amplifiers into place on both sides. Make sure to use end plates when cascading multiple amplifiers together. Two pcs. per set

OPTIONS

Amplifier mounting bracket

- **MS-DIN-2**

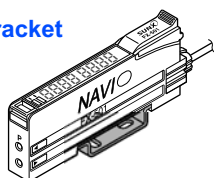

Amplifier protection seal

- **FX-MB1**
10 sets of 2 communication window seals and 1 connector seal 07/2010

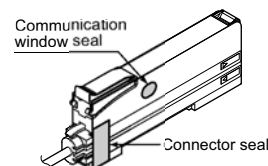

SPECIFICATIONS

Item	Model No.	Type	Standard type	2-output type	Cable type
		NPN output	FX-501	FX-502	FX-505-C2
		PNP output	FX-501P	FX-502P	FX-505P-C2
Supply voltage			12 to 24 V DC \pm 10 % Ripple P-P 10 % or less		
Power consumption			Normal operation: 960 mW or less (current consumption 40 mA or less at 24 V supply voltage, excluding analog output of cable type) ECO mode: 680 mW or less (current consumption 28 mA or less at 24 V supply voltage, excluding analog output of cable type)		
Output (2-output type and cable type: Output 1, Output 2)			<NPN output type> NPN open-collector transistor • Maximum sink current: 100 mA (2-output type and cable type are 50 mA) (Note 2) • Applied voltage: 30 V DC or less (between output and 0 V) • Residual voltage: 2 V or less (Note 3) (at maximum sink current)	<PNP output type> PNP open-collector transistor • Maximum source current: 100 mA (2-output type and cable type are 50 mA) (Note 2) • Applied voltage: 30 V DC or less (between output and +V) • Residual voltage: 2 V or less (Note 3) (at maximum source current)	
	Output points		1 point	2 points	
	Output operation		Switchable either Light-ON or Dark-ON by L/D mode		
	Short-circuit protection		Incorporated		
Response time			H-SP: 25 μ s or less, FAST: 60 μ s or less, STD: 250 μ s or less, LONG: 2 ms or less, U-LG: 4 ms or less, HYPR: 24 ms or less, selectable		
Analog output			Output current: 4 to 20 mA approx. [H-SP, FAST STD: At 0 to 4,000 digits, LONG: At 0 to 8,000 digits (Note 4)], Response time: 2 ms or less, Zero point: Within 4 mA \pm 1 % F.S., Span: Within 16 mA \pm 5 % F.S., Linearity: Within \pm 3 % F.S., Load resistance: 0 to 250 Ω		
External input (2-output type only, switchable with Output 2)		————	<NPN output type> NPN non-contact input • Signal condition High: +8 V to +V DC or Open Low: 0 to +1.2 V DC (at 0.5 mA source current) • Input impedance: 10 k Ω approx.	<PNP output type> PNP non-contact input • Signal condition High: +4 V to +V DC (at 3 mA sink current) Low: 0 to +0.6 V DC or Open • Input impedance: 10 k Ω approx.	
Possible external input function		————	Emission halt / Teaching (Full-auto, Limit, 2-point) / Logic operation setting / Copy lock / Display adjustment / Data bank load / Data bank save, selectable		
Sensitivity setting			2-point teaching / Limit teaching / Full-auto teaching / Manual adjustment		
Incident light intensity display range			H-SP / FAST / STD: 0 to 4,000, LONG: 0 to 8,000, U-LG / HYPR: 0 to 9,999		
Timer function		Incorporated with variable OFF-delay / ON-delay / ONE SHOT / ON-delay • OFF-delay / ON-delay • ONE SHOT timer, switchable either effective or ineffective	<Output 1> Incorporated with variable OFF-delay / ON-delay / ONE SHOT / ON-delay • OFF-delay / ON-delay • ONE SHOT timer, switchable either effective or ineffective		
	Timer period	Timer range "ms": 0.5 ms approx., 1 to 9,999 ms approx., 1 ms approx., Timer range "sec.": 0.5 s approx., 1 to 32 s approx., 1 s approx., Timer range "1/10 ms": 0.05 ms approx., 0.1 to 999.9 ms approx., 0.1 ms approx., each output is set individually	<Output 2> Incorporated with variable OFF-delay / ON-delay / ONE SHOT timer, switchable either effective or ineffective		
Light emitting amount selection function			Incorporated, 3 levels (each level 25 to 100 %) + Auto setting [1 level (25 to 100 %) when using H-SP mode]		
Interference prevention function			Incorporated (Note 5), selectable either automatic interference prevention or different frequency		
Various settings			Hysteresis setting / Shift amount setting / Emission power setting / Display turning setting / ECO setting / Data bank loading saving setting / Copying setting / Code setting / Reset setting / Logical calculation setting / Threshold tracking setting, etc.		
Protection			IP40 (IEC)		
Ambient temperature			-10 to +55 °C +14 to +131 °F [If 4 to 7 units are mounted in cascade: -10 to +50 °C +14 to +122 °F or if 8 to 16 units (cable type: 8 to 12 units) are mounted in cascade: -10 to +45 °C +14 to +113 °F] (No dew condensation or icing allowed), Storage: -20 to +70 °C -4 to +158 °F		
Emitting element (modulated)			Red LED (Peak emission wavelength: 650 nm 0.026 mil)		
Material			Enclosure: Heat-resistant ABS (Cable type: Polycarbonate), Case cover: Polycarbonate, Switch: TPEE		
Cable		————	0.2 mm ² 6-core cabtyre cable, 2 m 6.562 ft long		
Cable extension		————	Extension up to total 100 m 328.084 ft is possible with 0.3 mm ² , or more, cable. (however, supply voltage 12 V DC)		
Weight			Net weight: 15 g approx., Gross weight: 70 g approx.		Net weight: 60 g approx., Gross weight: 100 g approx.
Accessory			FX-MB1 (Amplifier protection seal): 1 set		

Notes: 1) Where measurement conditions have not been specified precisely, the conditions used were an ambient temperature of +23 °C **+73.4 °F**.

2) 50 mA max. if 5 or more standard types are connected together. (25 mA in case of 2-output type)

3) In case of using the quick-connection cable (cable length 5 m **16.404 ft**) (optional).

4) If display adjustment was conducted, it is not in this range.

5) Number of sensor heads which is possible to be mounted closely in auto interference prevention function depends on response time as shown in table below.
Number of sensor heads which is possible to be mounted closely in different frequency Interference prevention function is up to 3 units.

• Number of sensor heads mountable closely (Unit: set)

Response time	H-SP	FAST	STD	LONG	U-LG	HYPR
IP-1	0	2	4	8	8	12

07/2010

I/O CIRCUIT AND WIRING DIAGRAMS

FX-501

NPN output type

I/O circuit diagram

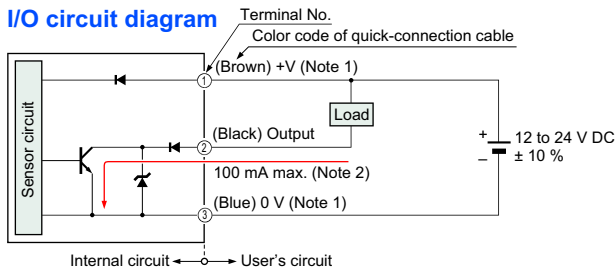

Notes: 1) The quick-connection sub cable does not have +V (brown) and 0 V (blue). The power is supplied from the connector of the main cable.
2) 50 mA max., if five amplifiers, or more, are connected together.

Wiring diagram

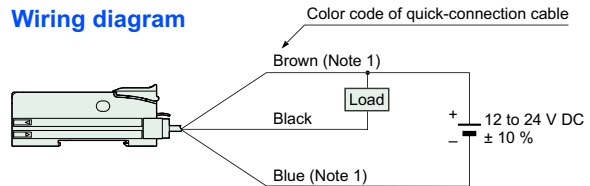

Note: The quick-connection sub cable does not have brown lead wire and blue lead wire.

Terminal arrangement diagram

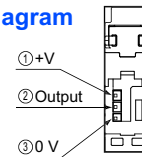

FX-501P

PNP output type

I/O circuit diagram

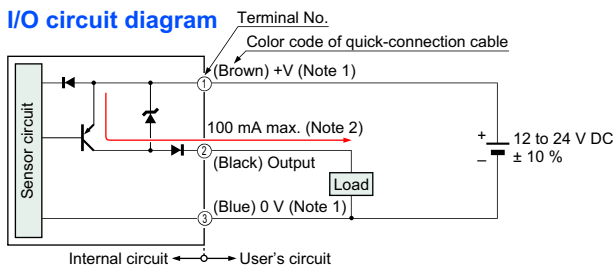

Notes: 1) The quick-connection sub cable does not have +V (brown) and 0 V (blue). The power is supplied from the connector of the main cable.
2) 50 mA max., if five amplifiers, or more, are connected together.

Wiring diagram

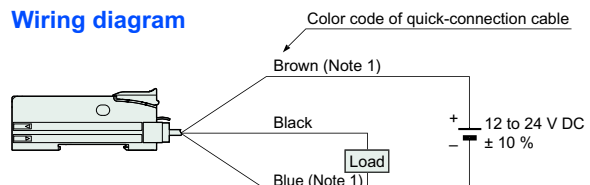

Note: The quick-connection sub cable does not have brown lead wire and blue lead wire.

Terminal arrangement diagram

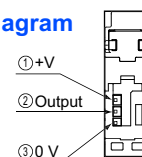

FX-502

NPN output type

I/O circuit diagram

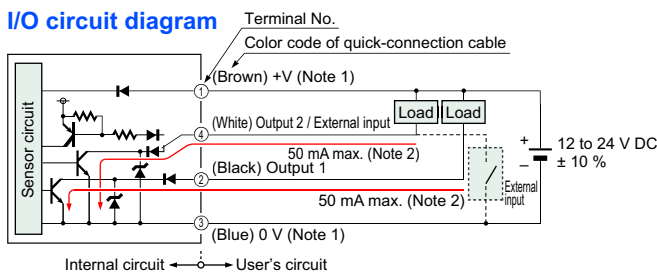

Notes: 1) The quick-connection sub cable does not have +V (brown) and 0 V (blue). The power is supplied from the connector of the main cable.
2) 25 mA max., if five amplifiers, or more, are connected together.

Wiring diagram

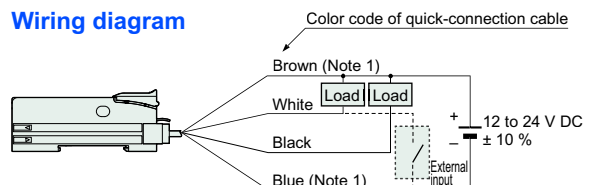

Note: The quick-connection sub cable does not have brown lead wire and blue lead wire.

Terminal arrangement diagram

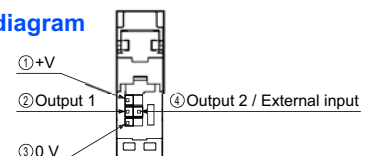

FX-502P

PNP output type

I/O circuit diagram

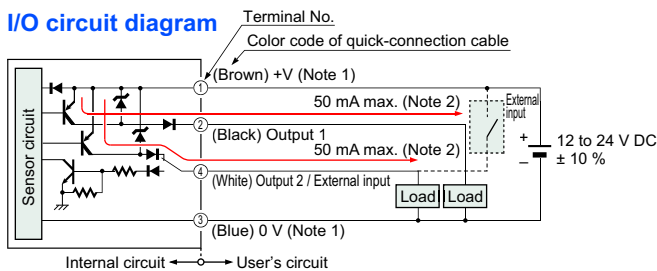

Notes: 1) The quick-connection sub cable does not have +V (brown) and 0 V (blue). The power is supplied from the connector of the main cable.
2) 25 mA max., if five amplifiers, or more, are connected together.

Wiring diagram

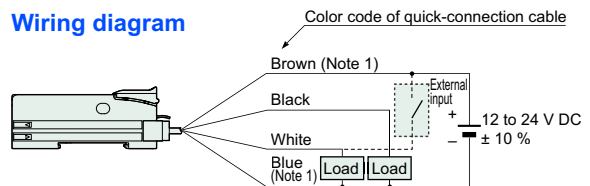

Note: The quick-connection sub cable does not have brown lead wire and blue lead wire.

Terminal arrangement diagram

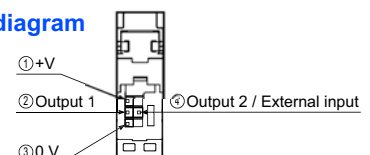

I/O CIRCUIT AND WIRING DIAGRAMS

FX-505-C2

NPN output type

I/O circuit diagram

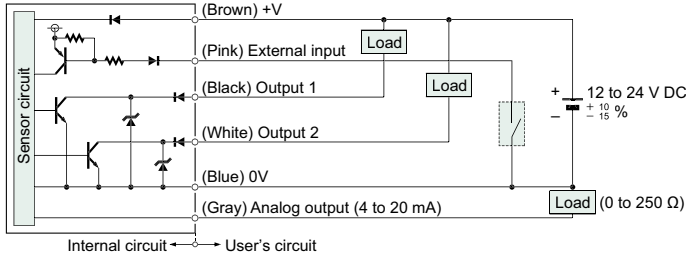

Wiring diagram

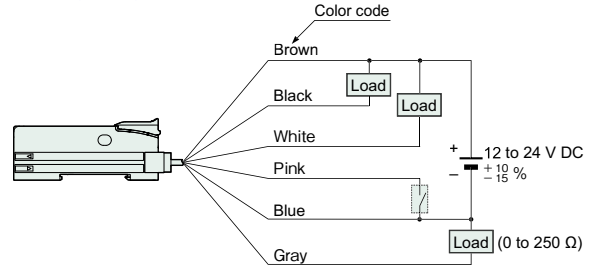

FX-505P-C2

PNP output type

I/O circuit diagram

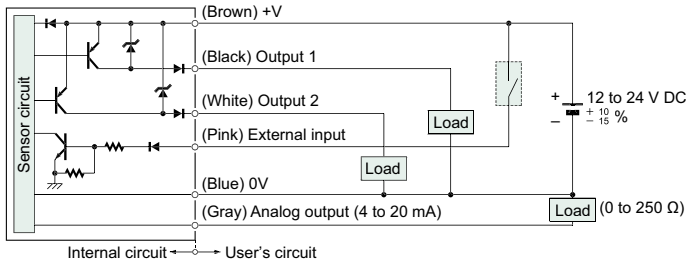

Wiring diagram

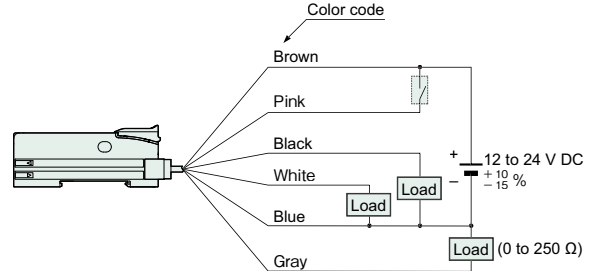

Super Quality Fibers

A quality that surpasses standard fiber

LIST OF SUPER QUALITY FIBERS

Thru-beam type (one pair set)



Type	Shape of fiber head (mm in)	Sensing range (mm in)			U-LG LONG FAST	Beam axis dia. (mm in)	Fiber cable length	Bending radius	Ambient temperature	Model No.
		■ : HYPR	■ : STD	■ : H-SP						
Threaded	M4	3,600 (Note) 141.732	1,200 47.244	190 7.480	U-LG: 2,200 86.614 LONG: 1,700 66.929 FAST: 530 20.866	ø1 ø0.039	2 m 6.562 ft	R4 mm R0.157 in Allowable bending radius	-55 to +80 °C -67 to +176 °F	FT-40
	M3	1,350 53.150	400 15.748	75 2.953	U-LG: 810 31.890 LONG: 650 25.591 FAST: 210 8.268	ø0.5 ø0.020				FT-30
Cylindrical	ø3 ø0.118	3,600 (Note) 141.732	1,200 47.244	190 7.480	U-LG: 2,200 86.614 LONG: 1,700 66.929 FAST: 530 20.866	ø1 ø0.039				FT-S30
	ø1.5 ø0.059	1,350 53.150	400 15.748	75 2.953	U-LG: 810 31.890 LONG: 650 25.591 FAST: 210 8.268	ø0.5 ø0.020				FT-S20

Note: The fiber cable length practically limits the sensing range to 3,600 mm 141.732 in long.

Reflective type

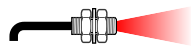

Type	Shape of fiber head (mm in)	Sensing range (mm in)			U-LG LONG FAST	Fiber cable length	Bending radius	Ambient temperature	Model No.
		■ : HYPR	■ : STD	■ : H-SP					
Threaded	M6	1,550 61.024	520 20.472	90 3.543	U-LG: 900 35.433 LONG: 740 29.134 FAST: 260 10.236	2 m 6.562 ft	R4 mm R0.157 in Allowable bending radius	-55 to +80 °C -67 to +176 °F	FD-60
	M4	600 23.622	160 6.299	25 0.984	U-LG: 330 12.992 LONG: 250 9.843 FAST: 80 3.150				FD-40
	M3	600 23.622	160 6.299	25 0.984	U-LG: 330 12.992 LONG: 250 9.843 FAST: 80 3.150				FD-30
Cylindrical	ø3 ø0.118	600 23.622	160 6.299	25 0.984	U-LG: 330 12.992 LONG: 250 9.843 FAST: 80 3.150				FD-S30

SUPER QUALITY FIBER SPECIFICATIONS

Item	Type	Thru-beam type	Reflective type
	Model No.	FT-40, FT-30, FT-S30, FT-S20	FD-60, FD-40, FD-30, FD-S30
Variation of fiber head		Within ±10 % (Note 2)	
Beam axis precision		Beam axis position: Within ±150 µm, Inclination of beam axis: Within ±2° (Note 3) Beam axis position: Within ±150 µm, Inclination of beam axis: Within ±3° (Note 3)	
Allowable bending radius		R4 mm R0.157 in or more	
Bending durability		10 million times or more (Note 4)	
Ambient temperature		-55 to +80 °C -67 to +176 °F (No dew condensation or icing allowed) (Note 5), Storage: -55 to +80 °C -67 to +176 °F	
Ambient humidity		35 to 85 % RH (Note 5), Storage: 35 to 85 % RH	
Material	Fiber core	Acrylic	
	Sheath	Polyethylene	
	Fiber head	Stainless steel (SUS303)	
	Plug	ABS	
Accessories		All fibers: FX-AT2 (fiber attachment) 1 pc. Threaded head fibers: Nuts 2 pcs. (Thru-beam type: 4 pcs.) and toothed lock washer 1 pc. (Thru-beam type: 2 pcs.)	

- Notes: 1) Where measurement conditions have not been specified precisely, the conditions used were an ambient temperature of +23 °C +73.4 °F.
- 2) The value is in standard condition [+23 °C +73.4 °F / 50 % RH, no bending fiber (R50 mm R1.969 in or more)].
- 3) The value is based on outer shape of fiber head.
- 4) It has a repeat flexibility as below.

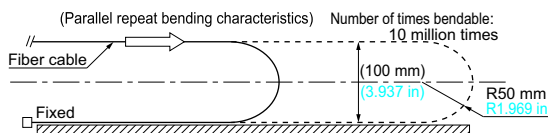

- 5) The ambient temperatures are the values for dry conditions. The ambient temperatures will vary for environments with high humidity. The ambient temperature for environments with high relative humidity of 85 % RH is -55 to +70 °C -67 to 07/2010 when the ambient humidity is +80 °C +176 °F, the ambient humidity is 35 to 50 % RH.

LIST OF FIBERS

Pliable fibers (flexible and sharp bending fibers) are marked in light blue in the table.

Thru-beam type (one pair set)



Type	Shape of fiber head (mm in)	Sensing range (mm in) (Note 1)		Beam axis dia. (mm in)	Fiber cable length Free-cut	Bending radius	Ambient temperature	Model No.										
		HYPR	STD						H-SP	U-LG LONG FAST								
Threaded type	Lens mountable (FX-LE1/LE2/SV1) M4 15 0.591	3,600 (Note 2)	141.732	1,250	49.213	180	7.087	U-LG : 2,400 LONG : 2,100 FAST : 570	2,400 94.488 82.677 22.441	∅1.5 ∅0.059	2 m 6.562 ft	R25 mm R0.984 in	-40 to +70 °C -40 to +158 °F	FT-B8				
		Metal-free													FT-41			
	Lens mountable (FX-LE1/LE2/SV1) M4 15 0.591	3,300	129.921	1,100	43.307				U-LG : 2,000 LONG : 1,550 FAST : 445	2,000 78.740 61.024 17.520				∅1 ∅0.039	Fiber R25 mm R0.984 in Sleeve R10 mm R0.394 in		FT-FM2	
	Sleeve 90 mm 3.543 in ∅1.48 ∅0.058 12 0.472			150	5.906												FT-FM2S	
	Sleeve 40 mm 1.575 in ∅1.48 ∅0.058 12 0.472																FT-FM2S4	
	Lens mountable (FX-LE1/LE2/SV1) M4 15 0.591	3,300	129.921	790	31.102	140	5.512		U-LG : 1,800 LONG : 1,400 FAST : 420	1,800 70.866 55.118 16.535						R1 mm R0.039 in	-40 to +60 °C -40 to +140 °F	FT-W8
	Lens mountable (FX-LE1/LE2/SV1) M4 15 0.591	3,300	129.921	810	31.890	160	6.299		U-LG : 2,000 LONG : 1,500 FAST : 470	2,000 78.740 59.055 18.504						R4 mm R0.157 in Flexible	-40 to +70 °C -40 to +158 °F	FT-P80
	Lens mountable (FX-LE1/LE2/SV1) Tough flexible M4 20 0.787	1,600 (Note 3)	62.992	880	34.646	160	6.299		U-LG : 1,600 LONG : 1,600 FAST : 530	1,600 62.992 20.866					1 m 3.281 ft	R10 mm R0.394 in		FT-P81X
	Lens mountable (FX-LE1/LE2/SV1) M4 15 0.591	1,200	47.244	350	13.780	60	2.362		U-LG : 640 LONG : 560 FAST : 210	640 25.197 22.047 8.268				∅0.7 ∅0.028	2 m 6.562 ft	R4 mm R0.157 in Flexible	-40 to +60 °C -40 to +140 °F	FT-P60
	Square head type	W7 × H9 × D13.9 W0.276 × H0.354 × D0.547	2,600	102.362	660	25.984	130	5.118	U-LG : 1,300 LONG : 1,100 FAST : 410	1,300 51.181 43.307 16.142				∅1 ∅0.039	2 m 6.562 ft	R1 mm R0.039 in		FT-WR80
With lens			3,600 (Note 2)	141.732	2,200	86.614	470	18.504	U-LG : 3,600 LONG : 3,300 FAST : 1,300	3,600 141.732 129.921 51.181	∅2 ∅0.079				FT-WR80L			
Elbow	Lens mountable (FX-LE1/LE2) M4 14 0.551	3,500	137.795	780	30.709	140	5.512	U-LG : 1,750 LONG : 1,100 FAST : 450	1,750 68.898 43.307 17.717	∅1 ∅0.039	2 m 6.562 ft	R25 mm R0.984 in	-40 to +70 °C -40 to +158 °F	FT-R80				
M3	Lens mountable (FX-LE1/SV1) M3 12.5 0.492	3,300	129.921	1,100	43.307	150	5.906	U-LG : 2,000 LONG : 1,550 FAST : 445	2,000 78.740 61.024 17.520	∅1 ∅0.039	2 m 6.562 ft	R25 mm R0.984 in	-40 to +70 °C -40 to +158 °F	FT-T80				
		1,220	48.031	310	12.205	63	2.480	U-LG : 740 LONG : 545 FAST : 192	740 29.134 21.457 7.559	∅0.5 ∅0.020				FT-NFM2				

Notes: 1) Note that the sensing range of the free-cut type fiber may be reduced by 20 % max. depending upon how the fiber is cut.
 2) The fiber cable length practically limits the sensing range to 3,600 mm 141.732 in long.
 3) The fiber cable length practically limits the sensing range to 1,600 mm 62.992 in long.

LIST OF FIBERS

Pliable fibers (flexible and sharp bending fibers) are marked in light blue in the table.

Thru-beam type (one pair set)

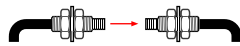

Type	Shape of fiber head (mm in)	Sensing range (mm in) (Note 1)		Beam axis dia. (mm in)	Fiber cable length (Free-cut)	Bending radius	Ambient temperature	Model No.	
		HYPR	STD						H-SP
Threaded type	Sleeve 90 mm 3.543 in M3 ø0.88 ø0.035 10 0.394	1,220	310		ø0.5 ø0.020	2 m 6.562 ft	-40 to +70 °C -40 to +158 °F	FT-NFM2S	
		48.031	12.205						U-LG : 740 LONG : 29.134 FAST : 545
	Sleeve 40 mm 1.575 in M3 ø0.88 ø0.035 10 0.394	63	250					U-LG : 590 LONG : 23.228 FAST : 150	FT-NFM2S4
		2.480	9.843					U-LG : 590 LONG : 23.228 FAST : 150	
	M3 ø0.88 ø0.035 10 0.394	960	250					U-LG : 590 LONG : 23.228 FAST : 150	FT-W4
37.795		9.843		U-LG : 590 LONG : 23.228 FAST : 150					
M3 ø0.88 ø0.035 10 0.394	650	160		U-LG : 360 LONG : 270 FAST : 95	ø0.6 ø0.024	R4 mm R0.157 in Flexible	-40 to +70 °C -40 to +140 °F	FT-P40	
	25.591	6.299		U-LG : 360 LONG : 270 FAST : 95					
Long sensing range	With lens M14 ø0.906	19,600 (Note 2)	19,600 (Note 2)		ø10 ø0.394	10 m 32.808 ft	-40 to +70 °C -40 to +158 °F	FT-FM10L	
		771.652	771.652						U-LG : 19,600 LONG : 19,600 FAST : 13,000
Cylindrical type	With lens • Long sensing range ø3 ø0.118 8 0.315	3,600 (Note 3)	3,300		ø2 ø0.079	2 m 6.562 ft	-40 to +60 °C -40 to +140 °F	FT-WS8L	
		141.732	129.921						U-LG : 3,600 LONG : 3,500 FAST : 1,700
	ø3 ø0.118 15 0.591	790	3,300		U-LG : 1,900 LONG : 1,400 FAST : 460	ø1 ø0.039	R1 mm R0.039 in	-40 to +60 °C -40 to +140 °F	FT-WS3
		31.102	129.921		U-LG : 1,900 LONG : 1,400 FAST : 460				
	With lens • Long sensing range ø2.5 ø0.098 8 0.315	3,600 (Note 3)	2,600		ø2 ø0.079	2 m 6.562 ft	-40 to +70 °C -40 to +158 °F	FT-SFM2L	
		141.732	102.362						U-LG : 3,600 LONG : 3,500 FAST : 1,400
	ø2.5 ø0.098 8 0.315	3,300	1,100		U-LG : 2,000 LONG : 1,550 FAST : 445	ø1 ø0.039	R25 mm R0.984 in	-40 to +60 °C -40 to +158 °F	FT-SFM2
		43.307	43.307		U-LG : 2,000 LONG : 1,550 FAST : 445				
	ø2.5 ø0.098 8 0.315	3,300	790		U-LG : 1,800 LONG : 1,400 FAST : 420	ø0.6 ø0.024	R1 mm R0.039 in	-40 to +60 °C -40 to +140 °F	FT-WS8
		129.921	31.102		U-LG : 1,800 LONG : 1,400 FAST : 420				
ø1.5 ø0.059 8 0.315	1,220	310		ø0.5 ø0.020	2 m 6.562 ft	-40 to +70 °C -40 to +158 °F	FT-SNFM2		
	48.031	12.205						U-LG : 740 LONG : 29.134 FAST : 545	
ø1.5 ø0.059 8 0.315	960	250		U-LG : 590 LONG : 23.228 FAST : 150	ø0.6 ø0.024	R25 mm R0.984 in	-40 to +60 °C -40 to +158 °F	FT-WS4	
	37.795	9.843		U-LG : 590 LONG : 23.228 FAST : 150					
ø1.5 ø0.059 10 0.394	1,200	330		U-LG : 770 LONG : 570 FAST : 200	ø0.6 ø0.024	R4 mm R0.157 in Flexible	-40 to +70 °C -40 to +158 °F	FT-P2	
	47.244	12.992		U-LG : 770 LONG : 570 FAST : 200					
ø1 ø0.039 6 0.236	350	90		ø0.25 ø0.010	500 mm 19.685 in	-40 to +60 °C -40 to +140 °F	FT-PS1		
	13.780	3.543						U-LG : 210 LONG : 160 FAST : 60	

Notes: 1) Note that the sensing range of the free-cut type fiber may be reduced by 20 % max. depending upon how the fiber is cut.
 2) The fiber cable length practically limits the sensing range to 19,600 mm 771.652 in long.
 3) The fiber cable length practically limits the sensing range to 3,600 mm 141.732 in long.

LIST OF FIBERS

Pliable fibers (flexible and sharp bending fibers) are marked in light blue in the table.

Thru-beam type (one pair set)



Type	Shape of fiber head (mm in)	Sensing range (mm in) (Note 1)		Beam axis dia. (mm in)	Fiber cable length ✂: Free-cut	Bending radius	Ambient temperature	Model No.				
		■ : HYPR ■ : STD ■ : H-SP	U-LG LONG FAST									
Cylindrical type Side-view		3,600 (Note 2) 141.732 3,500 137.795 850 33.465	U-LG : 3,600 LONG : 3,600 FAST : 2,400	141.732 141.732 141.732 94.488	ø2.5 ø0.098	✂ 2 m 6.562 ft	R25 mm R0.984 in	-40 to +60 °C -40 to +140 °F	FT-V10			
		2,200 86.614 570 22.441 100 3.937	U-LG : 1,300 LONG : 1,000 FAST : 360	51.181 39.370 14.173	ø1.1 ø0.043	✂ 2 m 6.562 ft	R25 mm R0.984 in	-20 to +70 °C -4 to +158 °F	FT-SFM2SV2			
		1,200 47.244 300 11.811 90 3.543	U-LG : 600 LONG : 490 FAST : 200	23.622 19.291 7.874	ø0.8 ø0.031	✂ 1 m 3.281 ft	R25 mm R0.984 in	-20 to +60 °C -4 to +140 °F	FT-V22			
		790 31.102 200 7.874 40 1.575	U-LG : 450 LONG : 360 FAST : 130	17.717 14.173 5.118	ø0.55 ø0.022	✂ 2 m 6.562 ft	R25 mm R0.984 in	-40 to +60 °C -40 to +140 °F	FT-V41			
		380 14.961 100 3.937 20 0.787	U-LG : 220 LONG : 170 FAST : 60	8.661 6.693 2.362	ø0.5 ø0.020	✂ 2 m 6.562 ft	R1 mm R0.039 in	-40 to +60 °C -40 to +140 °F	FT-WV42			
Rectangular type Compact	Easy mounting • Top sensing W3 × H8 × D12 W0.118 × H0.315 × D0.472	3,600 (Note 2) 141.732 3,300 129.921 630 24.803	U-LG : 3,600 LONG : 3,300 FAST : 1,800	141.732 141.732 129.921 70.866	2.2 × 3 0.087 × 0.118	✂ 2 m 6.562 ft	-40 to +60 °C -40 to +140 °F	R1 mm R0.039 in	FT-WZ8H			
	Easy mounting • Side sensing W3 × H12 × D8 W0.118 × H0.472 × D0.315	3,600 (Note 2) 141.732 3,400 133.858 590 23.228	U-LG : 3,600 LONG : 3,600 FAST : 1,850	141.732 141.732 141.732 72.835				R4 mm R0.157 in	Flexible	FT-Z8H		
		3,600 (Note 2) 141.732 2,000 78.740 490 19.291	U-LG : 3,600 LONG : 3,300 FAST : 1,300	141.732 129.921 51.181				R1 mm R0.039 in	Flexible	FT-WZ8E		
	Easy mounting • Front sensing W8.5 × H12 × D3 W0.335 × H0.472 × D0.118	3,600 (Note 2) 141.732 1,300 51.181 280 11.024	U-LG : 3,100 LONG : 2,300 FAST : 830	122.047 90.551 32.677				R1 mm R0.039 in	Flexible	FT-WZ8		
		3,600 (Note 2) 141.732 1,200 47.244 250 9.843	U-LG : 2,700 LONG : 2,100 FAST : 750	106.299 82.677 29.528				R4 mm R0.157 in	Flexible	FT-Z8		
	Front sensing W10 × H7 × D2 W0.394 × H0.278 × D0.079	1,600 (Note 3) 62.992 530 20.866 100 3.937	U-LG : 1,100 LONG : 900 FAST : 330	43.307 35.433 12.992				ø1.5 ø0.059	✂ 1 m 3.281 ft			FT-WZ4
	Fiber bending type W2 × H10 × D10 W0.079 × H0.394 × D0.394	800 31.496 210 8.268 40 1.575	U-LG : 460 LONG : 370 FAST : 130	18.110 14.567 5.118				ø0.5 ø0.020	✂ 1 m 3.281 ft	R1 mm R0.039 in		FT-WZ4HB
	Front sensing W14 × H7 × D3.5 W0.551 × H0.278 × D0.138	3,500 137.795 1,400 55.118 290 11.417	U-LG : 3,300 LONG : 2,300 FAST : 890	129.921 90.551 35.039				ø1.5 ø0.059	✂ 2 m 6.562 ft			FT-WZ7
	Fiber bending type W3.5 × H14 × D11 W0.138 × H0.551 × D0.433	3,500 137.795 790 31.102 160 6.299	U-LG : 1,700 LONG : 1,300 FAST : 490	66.929 51.181 19.291				ø1 ø0.039	✂ 2 m 6.562 ft			FT-WZ7HB

Notes: 1) Note that the sensing range of the free-cut type fiber may be reduced by 20 % max. depending upon how the fiber is cut.
 2) The fiber cable length practically limits the sensing range to 3,600 mm 141.732 in long.
 3) The fiber cable length practically limits the sensing range to 1,600 mm 62.992 in long.

LIST OF FIBERS

Pliable fibers (flexible and sharp bending fibers) are marked in light blue in the table.

Thru-beam type (one pair set)



Type	Shape of fiber head (mm in)	Sensing range (mm in) (Note 1)		Beam axis dia. (mm in)	Fiber cable length	Bending radius	Ambient temperature	Model No.	
		■ : HYPR ■ : STD ■ : H-SP	U-LG LONG FAST						
Special	Narrow beam 	■ : 3,600 (Note 2) 141.732	U-LG : 3,600 141.732	0.2.2 0.087	Free-cut	R25 mm R0.984 in		FT-K8	
		■ : 3,600 (Note 2) 141.732	LONG : 3,600 141.732						
		■ : 750 29.528	FAST : 2,700 106.299						
	Narrow beam 	■ : 3,600 (Note 2) 141.732	U-LG : 3,600 141.732	0.2.5 0.098	2 m 6.562 ft	R1 mm R0.039 in	-40 to +60 °C -40 to +140 °F	FT-WKV8	
		■ : 3,600 (Note 2) 141.732	LONG : 3,600 141.732						
		■ : 760 29.921	FAST : 2,400 94.488						
	Narrow beam 	■ : 2,400 94.488	U-LG : 1,100 43.307	0.1 0.039		R10 mm R0.394 in		FT-KV1	
		■ : 540 21.260	LONG : 850 33.465						
		■ : 160 6.299	FAST : 430 16.929						
	Wide beam	Wide area sensing 	■ : 3,600 (Note 2) 141.732	U-LG : 3,600 141.732	3.2 x 32 0.126		R1 mm R0.039 in	-40 to +55 °C -40 to +131 °F	FT-WA30
			■ : 3,600 (Note 2) 141.732	LONG : 3,600 141.732					
			■ : 3,300 129.921	FAST : 3,600 141.732					
Wide area sensing 		■ : 3,600 (Note 2) 141.732	U-LG : 3,600 141.732	2.2 x 11 0.087	2 m 6.562 ft	R1 mm R0.039 in	-40 to +55 °C -40 to +131 °F	FT-WA8	
		■ : 3,600 (Note 2) 141.732	LONG : 3,600 141.732						
		■ : 980 38.583	FAST : 3,300 129.921						
Wide area sensing 	■ : 3,600 (Note 2) 141.732	U-LG : 3,600 141.732	0.433		R10 mm R0.394 in	-40 to +70 °C -40 to +158 °F	FT-A8		
	■ : 3,500 137.795	LONG : 3,600 141.732							
	■ : 1,200 47.244	FAST : 3,300 129.921							
Array	Top sensing 	■ : 3,500 137.795	U-LG : 2,000 78.740	0.265 x 5.5 0.010 x 0.217	2 m 6.562 ft	R25 mm R0.984 in	-40 to +70 °C -40 to +158 °F	FT-AFM2	
	Side sensing 	■ : 860 33.858	LONG : 1,500 59.055					FAST : 490 19.291	FT-AFM2E
Heat-resistant	350 °C 662 °F Lens mountable (FX-LE1/LE2/SV1) 	■ : 1,200 47.244	U-LG : 880 34.646	0.1.2 0.047	2 m 6.562 ft	R25 mm R0.984 in	-60 to +350 °C -76 to +662 °F	FT-H35-M2	
	350 °C 662 °F Sleeve 60 mm 2.362 in 	■ : 430 16.929	LONG : 670 26.378					FAST : 250 9.843	Fiber R25 mm R0.984 in Sleeve R10 mm R0.394 in
	Allows flexible wiring 200 °C 392 °F Lens mountable (FX-LE1/LE2/SV1) 	■ : 1,600 (Note 3) 62.992	U-LG : 1,000 39.370	0.0.8 0.031	1 m 3.281 ft	R10 mm R0.394 in	-60 to +200 °C	FT-H20W-M1	
	200 °C 392 °F Lens mountable (FX-LE1/LE2/SV1) 	■ : 470 18.504	LONG : 840 33.071					FAST : 300 11.811	FT-H20-M1
	200 °C 392 °F Lens mountable (FX-LE1/LE2/SV1) 	■ : 1,600 (Note 3) 62.992	U-LG : 1,300 51.181	0.1.2 0.047		R25 mm R0.984 in	-76 to +392 °F	FT-H20-M1	
	130 °C 266 °F Lens mountable (FX-LE2 only) 	■ : 540 21.260	LONG : 960 37.795					FAST : 330 12.992	FT-H13-FM2
130 °C 266 °F Lens mountable (FX-LE2 only) 	■ : 3,300 129.921	U-LG : 1,900 74.803	0.1.5 0.059	2 m 6.562 ft		-60 to +130 °C -76 to +266 °F	FT-H13-FM2		
	■ : 700 27.559	LONG : 1,300 51.181					FAST : 410 16.142		

Notes: 1) Note that the sensing range of the free-cut type fiber may be reduced by 20 % max. depending upon how the fiber is cut.
 2) The fiber cable length practically limits the sensing range to 3,600 mm 141.732 in long.
 3) The fiber cable length practically limits the sensing range to 1,600 mm 62.992 in long.

LIST OF FIBERS

Pliable fibers (flexible and sharp bending fibers) are marked in light blue in the table.

Thru-beam type (one pair set)



Type	Shape of fiber head (mm in)	Sensing range (mm in) (Note 1)		Beam axis dia. (mm in)	Fiber cable length (Free-cut)	Bending radius	Ambient temperature	Model No.						
		■ : HYPR ■ : STD ■ : H-SP	U-LG LONG FAST											
Heat-resistant • Joint	Lens mountable (FX-LE1/LE2/SV1)				U-LG : 1,000 LONG : 790 FAST : 300	200 mm 7.874 in (Note 2) 300 mm 11.811 in (Note 2) 500 mm 19.685 in (Note 2)	Heat-resistant fiber R18 mm R0.709 in (Note 3)	-60 to +200 °C -76 to +392 °F	FT-H20-J20-S (Note 4)					
					U-LG : 1,300 LONG : 980 FAST : 390	500 mm 19.685 in (Note 2) 800 mm 31.496 in (Note 2)			FT-H20-J30-S (Note 4)					
	Side-view			U-LG : 3,600 LONG : 3,600 FAST : 1,900	2 m 6.562 ft	R25 mm R0.984 in			0 to +60 °C 32 to +140 °F	FT-H20-J50-S (Note 4)				
				U-LG : 1,300 LONG : 980 FAST : 390						FT-H20-VJ50-S (Note 4)				
				U-LG : 1,300 LONG : 980 FAST : 390						FT-H20-VJ80-S (Note 4)				
Special	Easy mounting • Rectangular head SEMI S2 compliant W7 × H15 × D13 W0.276 × H0.591 × D0.512			U-LG : 3,600 LONG : 3,600 FAST : 1,900	2 m 6.562 ft	R25 mm R0.984 in	0 to +60 °C 32 to +140 °F	FT-Z802Y						
		Chemical-resistant						U-LG : 3,600 LONG : 3,600 FAST : 2,300	2 m 6.562 ft (Note 6)	R30 mm R1.181 in	-40 to +115 °C -40 to +239 °F	FT-HL80Y		
			U-LG : 3,600 LONG : 3,600 FAST : 2,800	2 m 6.562 ft (Note 6)				R30 mm R1.181 in				-40 to +70 °C -40 to +158 °F	FT-L80Y	
			U-LG : 2,800 LONG : 2,200 FAST : 800										2 m 6.562 ft (Note 6)	R30 mm R1.181 in
	Vacuum-resistant	300 °C 572 °F Lens mountable (FV-LE1/SV2 only)						U-LG : 590 LONG : 470 FAST : 160	1 m 3.281 ft	R18 mm R0.709 in	-30 to +300 °C -22 to +572 °F	FT-H30-M1V-S (Note 7)		

- Notes: 1) Note that the sensing range of the free-cut type fiber may be reduced by 20 % max. depending upon how the fiber is cut.
 2) This is the fiber length (fixed length) for heat-resistant fibers. The ordinary-temperature fibers are free-cut to 2 m 6.562 ft.
 3) The bending radius for the ordinary-temperature fiber is R25 mm R0.984 in or more.
 4) Heat-resistant joint fibers and ordinary-temperature fibers (FT-FM2) are sold as a set.
 5) The fiber cable length practically limits the sensing range to 3,600 mm 141.732 in long.
 6) The allowable cutting range is 500 mm 19.685 in from the end that the amplifier inserted.
 7) Sold as a set comprising vacuum type fiber + photo-terminal (FV-BR1) + fiber at atmospheric side (FT-J8).

Heat-resistant joint fiber set contents

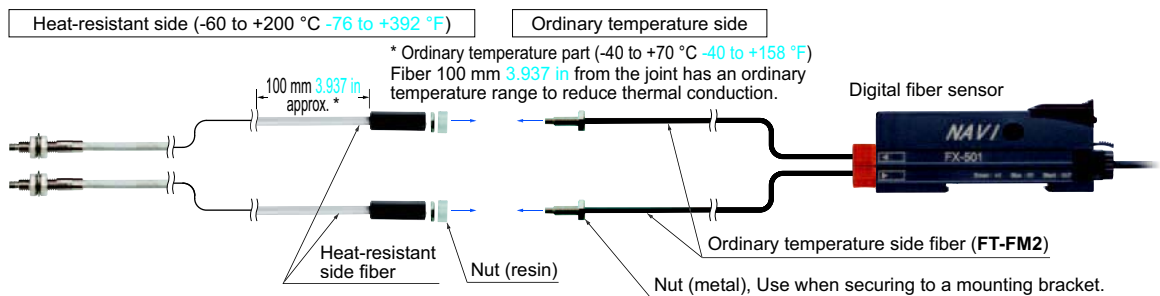

Model No. when ordering individual parts from spare parts

- Heat-resistant side fiber **one pair set**
 FT-H20-J20, FT-H20-J30, FT-H20-J50, FT-H20-VJ50, FT-H20-VJ80

LIST OF FIBERS

Pliable fibers (flexible and sharp bending fibers) are marked in light blue in the table.

Vacuum-resistant fiber set contents

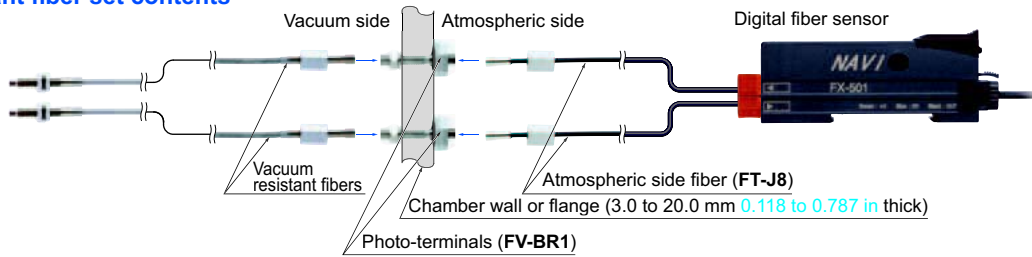

Model No. when ordering vacuum-resistant fibers individually as replacement parts

- Vacuum-resistant fiber **FT-H30-M1V** (one pair set)
- Photo-terminal **FV-BR1** (one pair set)
- Fiber at atmospheric side **FT-J8** (one pair set)

Retroreflective type

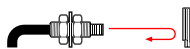

Type	Shape of fiber head (mm in)	Sensing range (mm in) (Note 1) (Note 2)		Fiber cable length 2 m 6.562 ft	Bending radius R1 mm R0.039 in	Ambient temperature -25 to +55 °C -13 to +131 °F	Model No.
		■ : HYPR ■ : STD ■ : H-SP	U-LG LONG FAST				
Sharp bending With polarizing filters	W9.5 × H5.2 × D15 W0.374 × H0.205 × D0.591 W30 × H30 × D0.5 W1.181 × H1.181 × D0.020	100 to 1,900 3.937 to 74.803 100 to 990 3.937 to 38.976 100 to 490 3.937 to 19.291	U-LG : 100 to 1,400 3.937 to 55.118 LONG : 100 to 1,200 3.937 to 47.244 FAST : 100 to 780 3.937 to 30.709	Free-cut	R1 mm R0.039 in	-25 to +55 °C -13 to +131 °F	FR-WKZ11
Narrow beam Top sensing Side sensing	W9.5 × H5.2 × D21 W0.374 × H0.205 × D0.827 W10.6 × H28 × D10.1 W0.417 × H1.102 × D0.398	200 7.874 200 7.874	U-LG : 200 7.874 LONG : 200 7.874 FAST : 200 7.874	Free-cut	R10 mm R0.394 in	-40 to +60 °C -40 to +140 °F	FR-KZ21 FR-KZ21E
	W9.5 × H25 × D5.2 W0.374 × H0.984 × D0.205 W10.6 × H28 × D10.1 W0.417 × H1.102 × D0.398	200 7.874	FAST : 200 7.874	Free-cut	R10 mm R0.394 in	-40 to +60 °C -40 to +140 °F	FR-KV1
Wafer mapping	W7.5 × H22 × D11.2 W0.295 × H0.867 × D0.441 W4 × H2 × D21.5 W0.157 × H0.079 × D0.846	20 to 530 0.787 to 20.866 20 to 310 0.787 to 12.205 20 to 100 0.787 to 3.937	U-LG : 20 to 460 0.787 to 18.110 LONG : 20 to 410 0.787 to 16.142 FAST : 20 to 220 0.787 to 8.661	Free-cut	R10 mm R0.394 in	-40 to +60 °C -40 to +140 °F	FR-KV1

Notes: 1) Note that the sensing range of the free-cut type fiber may be reduced by 20 % max. depending upon how the fiber is cut. The sensing range of **FR-WKZ11** is specified for the **RF-13**. The sensing range of **FR-KZ21**, **FR-KZ21E** is specified for the attached reflector **RF-003**. The sensing range of **FR-KV1** is specified for the attached reflector. Refer to the table below for sensing range when **FR-WKZ11** is used in combination with a reflector (optional).

Reflector Amplifier	RF-230	RF-220	RF-210
FX-501(P)	100 to 3,600 3.937 to 141.732 (HYPR)	100 to 3,600 3.937 to 141.732 (HYPR)	100 to 2,500 3.937 to 98.425 (HYPR)
FX-502(P)	100 to 3,600 3.937 to 141.732 (U-LG)	100 to 3,000 3.937 to 118.110 (U-LG)	100 to 1,800 3.937 to 70.866 (U-LG)
	100 to 3,600 3.937 to 141.732 (LONG)	100 to 2,700 3.937 to 106.299 (LONG)	100 to 1,600 3.937 to 62.992 (LONG)
	100 to 3,500 3.937 to 137.795 (STD)	100 to 1,900 3.937 to 74.803 (STD)	100 to 1,200 3.937 to 47.244 (STD)
	100 to 2,900 3.937 to 114.173 (FAST)	100 to 1,500 3.937 to 59.055 (FAST)	100 to 960 3.937 to 37.795 (FAST)
	100 to 1,100 3.937 to 43.307 (H-SP)	100 to 900 3.937 to 35.433 (H-SP)	100 to 460 3.937 to 18.110 (H-SP)

- 2) The sensing range of **FR-WKZ11** is the possible setting range for the reflective tape. The fiber can detect an object less than 100 mm 3.937 in away. However, note that if there are any white or highly-reflective surfaces near the fiber head, reflected incident light may affect the fiber head. If this occurs, adjust the threshold value of the amplifier unit before use. The sensing range of **FR-KZ21** and **FR-KZ21E** is the possible setting range for the reflector. However, if setting the fiber to detect objects passing within 0 to 20 mm 0 to 0.787 in from the fiber head, unstable detection may result. The sensing range of **FR-KV1** is the possible setting range for the reflector. The fiber can detect an object less than 20 mm 0.787 in away.

LIST OF FIBERS

Pliable fibers (flexible and sharp bending fibers) are marked in light blue in the table.

Reflective type

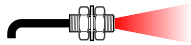

Type	Shape of fiber head (mm in)	Sensing range (mm in) (Note 1) (Note 2)		Fiber cable length ✂ : Free-cut	Bending radius	Ambient temperature	Model No.	
		■ : HYPR ■ : STD ■ : H-SP	U-LG LONG FAST					
Threaded type	M6 	1,450 57.087	490 19.291	100 3.937	U-LG : 960 37.795 LONG : 860 33.858 FAST : 330 12.992	R25 mm R0.984 in	FD-B8	
	Metal-free • Coaxial 	1,000 39.370	420 16.535	60 2.362	U-LG : 680 26.772 LONG : 600 23.622 FAST : 200 7.874		FD-G60	
	Coaxial 	1,400 55.118	420 16.535	60 2.362	U-LG : 800 31.496 LONG : 650 25.591 FAST : 200 7.874		FD-FM2	
	M6 	Sleeve 90 mm 3.543 in	1,100 43.307	380 14.961	70 2.756	U-LG : 700 27.559 LONG : 540 21.260 FAST : 220 8.661	Fiber R25 mm R0.984 in Sleeve R10 mm R0.394 in	FD-FM2S
	M6 	Sleeve 40 mm 1.575 in	870 34.252	250 9.843	45 1.772	U-LG : 560 22.047 LONG : 420 16.535 FAST : 140 5.512	R1 mm R0.039 in	FD-W8
	M6 		820 32.283	280 11.024	55 2.165	U-LG : 610 24.016 LONG : 480 18.898 FAST : 160 6.299	R4 mm R0.157 in Flexible	FD-P80
	M6 	Tough flexible	450 17.717	270 10.630	50 1.969	U-LG : 370 14.567 LONG : 330 12.992 FAST : 160 6.299	R10 mm R0.394 in	FD-P81X
	Elbow 		890 35.039	220 8.661	40 1.575	U-LG : 500 19.685 LONG : 370 14.567 FAST : 130 5.118	R25 mm R0.984 in	FD-R80
	M4	M4 	1,100 43.307	380 14.961	70 2.756	U-LG : 700 27.559 LONG : 540 21.260 FAST : 220 8.661	R25 mm R0.984 in	FD-T80
		M4 		510 20.079	120 4.724	22 0.866		U-LG : 280 11.024 LONG : 215 8.465 FAST : 70 2.756
M4 		Sleeve 90 mm 3.543 in	870 34.252	250 9.843	45 1.772	U-LG : 560 22.047 LONG : 420 16.535 FAST : 140 5.512	Fiber R25 mm R0.984 in Sleeve R10 mm R0.394 in	FD-NFM2S
M4 		Sleeve 40 mm 1.575 in	870 34.252	250 9.843	45 1.772	U-LG : 560 22.047 LONG : 420 16.535 FAST : 140 5.512	R1 mm R0.039 in	FD-NFM2S4
M4 		Sleeve 40 mm 1.575 in	330 12.992	80 3.150	12 0.472	U-LG : 180 7.087 LONG : 140 5.512 FAST : 45 1.772	Fiber R1 mm R0.039 in Sleeve R10 mm R0.394 in	FD-W44
M4 			870 34.252	250 9.843	45 1.772	U-LG : 560 22.047 LONG : 420 16.535 FAST : 140 5.512	R1 mm R0.039 in	FD-WT8









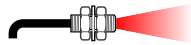

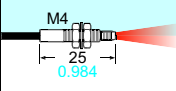

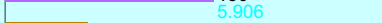



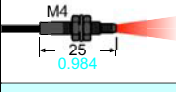
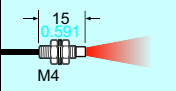

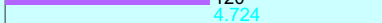
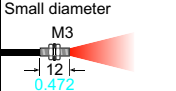





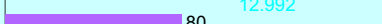

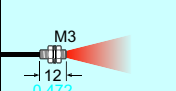



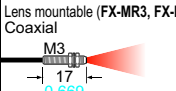



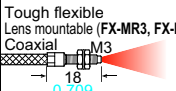



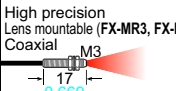



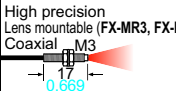



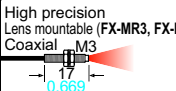



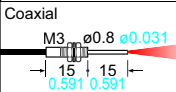

Notes: 1) The sensing range is specified for white non-glossy paper.
2) Note that the sensing range of the free-cut type fiber may be reduced by 20 % max. depending upon how the fiber is cut.

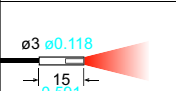
LIST OF FIBERS

Pliable fibers (flexible and sharp bending fibers) are marked in light blue in the table.

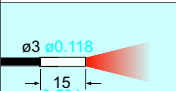
Reflective type



Type	Shape of fiber head (mm in)	Sensing range (mm in) (Note 1) (Note 2)		Fiber cable length ✂: Free-cut	Bending radius	Ambient temperature	Model No.
		■ : HYPR ■ : STD ■ : H-SP	U-LG LONG FAST				
Threaded type	Minute objects can be detected due to the small spot beam. Coaxial • Lens mountable (FX-MR1/MR2/MR3/MR5/MR6) 	 590  23.228  150 5.906  25 0.984	U-LG : 340 LONG : 13.386 FAST : 280 11.024 90 3.543		R2 mm R0.079 in	-40 to +60 °C -40 to +140 °F	FD-WG4
		 550  140 5.512  27 1.063	U-LG : 330 LONG : 12.992 FAST : 270 10.630 80 3.150	✂	R25 mm R0.984 in	-40 to +70 °C -40 to +158 °F	FD-G4
		Metal-free • Coaxial 			2 m 6.562 ft		
		 490  120 4.724  22 0.866	U-LG : 250 LONG : 9.843 FAST : 190 7.480 75 2.953		R4 mm R0.157 in Flexible	-40 to +60 °C -40 to +140 °F	FD-P60
	Small diameter 	 510  120 4.724  22 0.866	U-LG : 280 LONG : 11.024 FAST : 215 8.465 70 2.756		R25 mm R0.984 in	-40 to +70 °C -40 to +158 °F	FD-T40
		 330  80 3.150  12 0.472	U-LG : 180 LONG : 7.087 FAST : 140 5.512 45 1.772	✂	R1 mm R0.039 in	-40 to +60 °C -40 to +140 °F	FD-WT4
		 190  45 1.772  7 0.276	U-LG : 100 LONG : 3.937 FAST : 85 3.346 20 0.787	2 m 6.562 ft	R4 mm R0.157 in Flexible	-40 to +70 °C -40 to +158 °F	FD-P40
	Lens mountable (FX-MR3, FX-MR6) Coaxial 	 550  140 5.512  27 1.063	U-LG : 330 LONG : 12.992 FAST : 270 10.630 80 3.150		R25 mm R0.984 in	-40 to +60 °C	FD-G6
	Tough flexible Lens mountable (FX-MR3, FX-MR6) Coaxial 	 630  170 6.693  27 1.063	U-LG : 370 LONG : 14.567 FAST : 310 12.205 95 3.740	✂	R10 mm R0.394 in	-40 to +60 °C -40 to +140 °F	FD-G6X
	High precision Lens mountable (FX-MR3, FX-MR6) Coaxial 	 170  40 1.575  7.5 0.295	U-LG : 100 LONG : 3.937 FAST : 80 3.150 24 0.945		R25 mm R0.984 in		FD-EG1
High precision Lens mountable (FX-MR3, FX-MR6) Coaxial 	 130  24 0.945  3 0.118	U-LG : 100 LONG : 3.937 FAST : 80 3.150 19 0.748	500 mm 19.685 in	R10 mm R0.394 in	-20 to +60 °C -4 to +140 °F	FD-EG2	
High precision Lens mountable (FX-MR3, FX-MR6) Coaxial 	 85  20 0.787  3.5 0.138	U-LG : 45 LONG : 1.772 FAST : 35 1.378 12 0.472				FD-EG3	
Coaxial 	 190  50 1.969  9 0.354	U-LG : 110 LONG : 4.331 FAST : 90 3.543 28 1.102	1 m 3.281 ft	R25 mm R0.984 in		FD-ENM1S1	
Cylindrical type		 1,100  380 14.961  70 2.756	U-LG : 700 LONG : 27.559 FAST : 540 21.260 220 8.661	✂	R25 mm R0.984 in	-40 to +70 °C -40 to +158 °F	FD-S80
		 960  250 9.843  45 1.772	U-LG : 550 LONG : 21.654 FAST : 410 16.142 140 5.512	2 m 6.562 ft	R1 mm R0.039 in	-40 to +60 °C -40 to +140 °F	FD-WS8

Notes: 1) The sensing range is specified for white non-glossy paper.
 2) Note that the sensing range of the free-cut type fiber may be reduced by 20 % max. depending upon how the fiber is cut.
 3) The allowable cutting range is 700 mm 27.559 in from the end that the applicator is inserted.

LIST OF FIBERS

Pliable fibers (flexible and sharp bending fibers) are marked in light blue in the table.

Reflective type

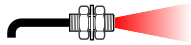

Type	Shape of fiber head (mm in)	Sensing range (mm in) (Note 1) (Note 2)		Fiber cable length ✂ : Free-cut	Bending radius	Ambient temperature	Model No.			
		■ : HYPR ■ : STD ■ : H-SP	U-LG LONG FAST							
Cylindrical type	Coaxial ø3 ø0.118 	■ : 590 ■ : 150 ■ : 25	U-LG : 340 LONG : 280 FAST : 90	 2 m 6.562 ft	R2 mm R0.079 in	-40 to +60 °C -40 to +140 °F	FD-WSG4			
		■ : 490 ■ : 120 ■ : 22	U-LG : 250 LONG : 190 FAST : 75					R4 mm R0.157 in Flexible	FD-P50	
	Coaxial ø2.5 ø0.098 	■ : 510 ■ : 120 ■ : 22	U-LG : 280 LONG : 215 FAST : 70	 2 m 6.562 ft	R25 mm R0.984 in	-40 to +70 °C -40 to +158 °F	FD-SNFM2			
	Coaxial ø1.5 ø0.059 	■ : 260 ■ : 80 ■ : 20	U-LG : 170 LONG : 140 FAST : 55					1 m 3.281 ft	R4 mm R0.157 in Flexible	FD-P2
	Ultra-small diameter ø1.5 ø0.5 ø0.059 ø0.020 Sleeve part cannot be bent.	■ : 45 ■ : 12 ■ : 2	U-LG : 25 LONG : 22 FAST : 7	1 m 3.281 ft	R10 mm R0.394 in	-40 to +60 °C -40 to +140 °F	FD-E12			
	Coaxial ø3 ø0.65 ø0.118 ø0.026 Sleeve part cannot be bent.	■ : 210 ■ : 55 ■ : 11	U-LG : 130 LONG : 110 FAST : 32					R25 mm R0.984 in	-40 to +70 °C -40 to +158 °F	FD-E22
	Small diameter ø3 ø1.5 ø0.118 ø0.059 Sleeve part cannot be bent.	■ : 260 ■ : 65 ■ : 14	U-LG : 140 LONG : 110 FAST : 35	R25 mm R0.984 in	-40 to +60 °C -40 to +140 °F	FD-V41				
	Side-view ø3 ø2 ø0.118 ø0.079 Sleeve part cannot be bent.	■ : 60 ■ : 16 ■ : 2	U-LG : 35 LONG : 25 FAST : 8				 2 m 6.562 ft	R1 mm R0.039 in	FD-WV42	
	Side-view ø5 ø2 ø0.197 ø0.079 Sleeve part cannot be bent.	■ : 370 ■ : 120 ■ : 25	U-LG : 250 LONG : 210 FAST : 75	R25 mm R0.984 in	-20 to +60 °C -4 to +140 °F	FD-SFM2SV2				
	Rectangular	Glass substrate detection • Mapping W25 × H7.3 × D30 W0.984 × H0.287 × D1.181	■ : 1 to 110 ■ : 1 to 56				U-LG : 1 to 87 LONG : 1 to 74 FAST : 1 to 38	 4 m 13.123 ft	R25 mm R0.984 in	-40 to +60 °C -40 to +140 °F
Cannot use ■ : 0.039 to 4.331 ■ : 0.039 to 2.205			U-LG : 3.425 LONG : 2.913 FAST : 1.496							
Convergent reflective type Glass substrate detection • Alignment W20 × H29 × D3.8 W0.787 × H1.142 × D0.150		■ : 43 ■ : 40 ■ : 24	U-LG : 43 LONG : 43 FAST : 40	 3 m 9.843 ft	R4 mm R0.157 in	-20 to +60 °C -4 to +158 °F	FD-L45			
		Glass substrate detection • Alignment W23.5 × H29 × D4.5 W0.925 × H1.142 × D0.177	■ : 3 to 51 ■ : 4 to 44 ■ : 5 to 38					U-LG : 4 to 47 LONG : 4 to 46 FAST : 4 to 42	R25 mm R0.984 in	FD-L45A
		Glass substrate detection • Alignment W17 × H29 × D3.8 W0.669 × H1.142 × D0.150	■ : 31 ■ : 24 ■ : 18					U-LG : 25 LONG : 24 FAST : 24		
		Glass substrate detection • Seating confirmation W18 × H29 × D3.8 W0.709 × H1.142 × D0.150	■ : 30 ■ : 29 ■ : 1.5 to 24					U-LG : 30 LONG : 30 FAST : 28	 3 m 9.843 ft	R4 mm R0.157 in

Notes: 1) The sensing range is specified for white non-glossy paper (FD-L46: 100 × 100 × t 0.7 mm 3.937 × 3.937 × t 0.028 in R edge of LCD glass substrates, FD-L45, FD-L45A, FD-L43 and FD-L47: 100 × 100 × t 0.7 mm 3.937 × 3.937 × t 0.028 in transparent glass) as the object.
 2) Note that the sensing range of the free-cut type fiber may be reduced by 20 % max. depending upon how the fiber is cut.

LIST OF FIBERS

Pliable fibers (flexible and sharp bending fibers) are marked in light blue in the table.

Reflective type



Type	Shape of fiber head (mm in)	Sensing range (mm in) (Note 1) (Note 2)		Fiber cable length ✂: Free-cut	Bending radius	Ambient temperature	Model No.
		■ : HYPR ■ : STD ■ : H-SP	U-LG LONG FAST				
Rectangular	Glass substrate detection • Seating confirmation W12 × H19 × D3 W0.472 × H0.748 × D0.118	■ 11.5 ■ 0.453 ■ 9.5 ■ 0.374 ■ 8 ■ 0.315	U-LG : 10.5 LONG : 10 FAST : 9	✂	R10 mm R0.394 in	-40 to +60 °C -40 to +140 °F	FD-L44
		■ 6 ■ 0.236 ■ 5 ■ 0.197 ■ 4 ■ 0.157	U-LG : 5.5 LONG : 5.5 FAST : 4.5				FD-L44S
	Glass substrate detection W24 × H21 × D4 W0.945 × H0.827 × D0.157	■ 1.5 to 15 ■ 0.059 to 0.591 ■ 2.5 to 14 ■ 0.098 to 0.551 ■ 6.5 to 10 ■ 0.256 to 0.394	U-LG : 2 to 14.5 LONG : 2 to 14.5 FAST : 5.5 to 13.5	✂	R1 mm R0.039 in		FD-WL41
		■ 1 to 19 ■ 0.039 to 0.748 ■ 1.5 to 16 ■ 0.059 to 0.630 ■ 8 to 11 ■ 0.315 to 0.433	U-LG : 1 to 18 LONG : 1.5 to 16 FAST : 3 to 15	✂	R10 mm R0.394 in		FD-L41
	W6 × H18 × D14 W0.236 × H0.709 × D0.551	■ 21.5 ■ 0.846 ■ 15.5 ■ 0.610 ■ 5 to 7.5 ■ 0.197 to 0.295	U-LG : 19.5 LONG : 18.5 FAST : 3 to 13			-40 to +70 °C -40 to +158 °F	FD-L4
W7.2 × H7.5 × D2 W0.283 × H0.295 × D0.079	■ 16 ■ 0.630 ■ 7.5 ■ 0.295 ■ 0.5 to 4 ■ 0.020 to 0.157	U-LG : 12.5 LONG : 11.5 FAST : 0.5 to 6	✂	R1 mm R0.039 in	-20 to +60 °C -4 to +140 °F	FD-WL48	
Small	Front sensing W10 × H7 × D2 W0.394 × H0.276 × D0.079	■ 1 to 230 ■ 0.039 to 9.055 ■ 2 to 65 ■ 0.079 to 2.559 ■ 5 to 13 ■ 0.197 to 0.512	U-LG : 1 to 110 LONG : 1 to 85 FAST : 3 to 35	✂			FD-WZ4
	Fiber bending type W2 × H10 × D10 W0.079 × H0.394 × D0.394	■ 1 to 190 ■ 0.039 to 7.480 ■ 2.5 to 65 ■ 0.098 to 2.559 ■ 3 to 11 ■ 0.118 to 0.433	U-LG : 1 to 130 LONG : 1 to 90 FAST : 2.5 to 40				FD-WZ4HB
	Front sensing W14 × H7 × D3.5 W0.551 × H0.276 × D0.138	■ 430 ■ 16.929 ■ 110 ■ 4.331 ■ 3 to 25 ■ 0.118 to 0.984	U-LG : 230 LONG : 180 FAST : 1.5 to 65	✂	R1 mm R0.039 in	-40 to +60 °C -40 to +140 °F	FD-WZ7
	Fiber bending type W3.5 × H14 × D11 W0.138 × H0.551 × D0.433	■ 0.5 to 560 ■ 0.020 to 22.047 ■ 1 to 150 ■ 0.039 to 5.906 ■ 2.5 to 30 ■ 0.098 to 1.181	U-LG : 0.5 to 320 LONG : 0.5 to 270 FAST : 1 to 90	✂			FD-WZ7HB
Special	Long sensing range • Rectangular head W52 × H9.5 × D15 W0.205 × H0.374 × D0.591	■ 20 to 1,700 ■ 0.787 to 66.929 ■ 20 to 490 ■ 0.787 to 19.291 ■ 20 to 100 ■ 0.787 to 3.937	U-LG : 20 to 1,000 LONG : 20 to 820 FAST : 20 to 310	✂	R1 mm R0.039 in	-40 to +60 °C -40 to +140 °F	FD-WKZ1
	Wide beam W7 × H15 × D30 W0.276 × H0.591 × D1.181	■ 200 ■ 7.874 ■ 200 ■ 7.874 ■ 75 ■ 2.953	U-LG : 200 LONG : 200 FAST : 140	✂	R25 mm R0.984 in		FD-A15
	Array Top sensing W5 × H20 × D20 W0.197 × H0.787 × D0.787	■ 660 ■ 25.984 ■ 280 ■ 11.024	U-LG : 510 LONG : 430 FAST : 160	✂	R25 mm R0.984 in	-40 to +70 °C -40 to +158 °F	FD-AFM2
Side sensing W5 × H20 × D20 W0.197 × H0.787 × D0.787	■ 50 ■ 1.969	FAST : 160 ■ 6.299				FD-AFM2E	

Notes: 1) The sensing range is specified for white non-glossy paper (FD-L44, FD-WL41 and FD-L41: 100 × 100 × t 0.7 mm 3.937 × 3.937 × t 0.028 in transparent glass, FD-L44S: silicon wafers polished surface) as the object.
 2) Note that the sensing range of the free-cut type fiber may be reduced by 20 % max. depending upon how the fiber is cut.

LIST OF FIBERS

Pliable fibers (flexible and sharp bending fibers) are marked in light blue in the table.

Reflective type

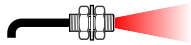

Type	Shape of fiber head (mm in)	Sensing range (mm in) (Note 1) (Note 2)		Fiber cable length ✂ : Free-cut	Bending radius	Ambient temperature	Model No.	
		■ : HYPR ■ : STD ■ : H-SP	U-LG LONG FAST					
Special	Liquid level sensing	Heat resistant 125 °C 257 °F Fluorine resin coating ø6 0.236	ø6 mm 0.236 in Protective tube: Fluorine resin, length 1,000 mm 39.370 in (not cuttable) Liquid surface contacted: Beam received, Liquid surface not contacted: Beam interrupted	2 m 6.562 ft (Note 3)	Protective tube R40 mm Fiber R15 mm	-40 to +125 °C -40 to +257 °F	FD-F8Y	
		Heat resistant 105 °C 221 °F Fluorine resin coating ø4 0.157	ø4 mm 0.157 in Protective tube: Fluorine resin, length 500 mm 19.685 in (cuttable) Liquid surface contacted: Beam received, Liquid surface not contacted: Beam interrupted	2 m 6.562 ft	Protective tube R20 mm Fiber R10 mm	-40 to +105 °C -40 to +221 °F	FD-HF40Y	
		Heat resistant 70 °C 158 °F Fluorine resin coating throughout the fiber ø4 0.157	ø4 mm 0.157 in Protective tube: Fluorine resin, length 500 mm 19.685 in (cuttable) Liquid surface contacted: Beam received, Liquid surface not contacted: Beam interrupted		Fiber R0.394 in	-40 to +70 °C -40 to +158 °F	FD-F41Y	
		Mountable on pipe • Standard W25 × H13 × D20 W0.984 × H0.512 × D0.787	Applicable pipe diameter: Outer dia. ø6 to ø26 mm 0.236 to 1.024 in transparent pipe [PVC (vinyl chloride), fluorine resin, polycarbonate, acrylic, glass, wall thickness 1 to 3 mm 0.039 to 0.118 in] Liquid absent: Beam received, Liquid present: Beam interrupted	2 m 6.562 ft	R10 mm R0.394 in	-40 to +100 °C -40 to +212 °F	FD-F41	
		Mountable on pipe • For PFA, wall thickness 1 mm 0.039 in pipe W25 × H13 × D20 W0.984 × H0.512 × D0.787	Applicable pipe diameter: Outer dia. ø6 to ø26 mm 0.236 to 1.024 in transparent pipe [PFA (fluorine resin) or equivalently transparent pipe, wall thickness 1 mm 0.039 in] Liquid absent: Beam received, Liquid present: Beam interrupted		R10 mm R0.394 in	-40 to +100 °C -40 to +212 °F	FD-F4	
	Liquid sensing	Mountable on pipe • Array fiber W6.5 × H28.3 × D17 W0.256 × H1.114 × D0.669	Applicable pipe diameter: Outer dia. ø8 mm 0.315 in or more transparent pipe (When used with the tying bands: ø8 to ø80 mm 0.315 to 3.150 in) [PFA (fluorine resin), including translucent] Liquid absent: Beam received, Liquid present: Beam interrupted	2 m 6.562 ft	R10 mm R0.394 in	-40 to +70 °C -40 to +158 °F	FD-FA90	
		Mountable on pipe SEMI S2 compliant W23 × H20 × D17 W0.906 × H0.787 × D0.669	Applicable pipe diameter: Outer dia. ø3 to ø10 mm 0.118 to 0.394 in transparent pipe [PFA (fluorine resin) or equivalently transparent pipe, wall thickness 0.3 to 1 mm 0.012 to 0.039 in] Liquid absent: Beam received, Liquid present: Beam interrupted	2 m 6.562 ft	Protective tube R20 mm Fiber R4 mm	-20 to +60 °C -4 to +140 °F	FT-F902	
		SEMI S2 compliant W20 × H30 × D10 W0.787 × H1.181 × D0.394	Liquid leak detection Leak absent: Beam received, Leak present: Beam interrupted		Protective tube R20 mm Fiber R4 mm	-20 to +50 °C -4 to +122 °F	FD-F705	
	Heat-resistant	350 °C 662 °F • Coaxial M6 25 0.984	720 28.346	U-LG : 540 LONG : 21.260 FAST : 150	2 m 6.562 ft	R25 mm R0.984 in	-60 to +350 °C -76 to +662 °F	FD-H35-M2
		350 °C 662 °F • Sleeve 60 mm 2.362 in M6 22 0.866	45 1.772	260 10.236		Fiber R25 mm Sleeve R10 mm	FD-H35-M2S6	
200 °C 392 °F • Coaxial M6 28 1.102		840 33.071	U-LG : 550 LONG : 500 FAST : 200	R25 mm R0.984 in	-60 to +200 °C -76 to +392 °F	FD-H20-M1		
350 °C 662 °F • Sleeve 90 mm 3.543 in M4 27 1.063		840 33.071	U-LG : 550 LONG : 440 FAST : 140	Fiber R25 mm Sleeve R10 mm	-60 to +350 °C -76 to +662 °F	FD-H35-20S		
200 °C 392 °F • Coaxial M4 27 1.063		770 30.315	U-LG : 500 LONG : 380 FAST : 130	R25 mm R0.984 in	-60 to +200 °C -76 to +392 °F	FD-H20-21		
300 °C 572 °F • Glass substrate detection Convergent reflective type W19 × H27 × D5 W0.748 × H1.063 × D0.197		40 1.575	U-LG : 30 LONG : 25 FAST : 12	2 m 6.562 ft	-60 to +300 °C -76 to +572 °F	FD-H30-L32		

Notes: 1) The sensing range is specified for white non-glossy paper (FD-H30-L32: 100 × 100 × t 0.7 mm 3.937 × 3.937 × t 0.028 in transparent glass) as the object.

2) Note that the sensing range of the free-cut type fiber may be reduced by 20 % max. depending upon how the fiber is cut.

3) The allowable cutting range is 1,000 mm 39.370 in from the end that the amplifier inserted.

LIST OF FIBERS

Pliable fibers (flexible and sharp bending fibers) are marked in light blue in the table.

Reflective type

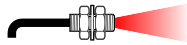

Type	Shape of fiber head (mm in)	Sensing range (mm in) (Note 1) (Note 2)		Fiber cable length ✂️: Free-cut	Bending radius	Ambient temperature	Model No.	
		■ : HYPR ■ : STD ■ : H-SP	U-LG LONG FAST					
Special	250 °C 482 °F • Glass substrate detection Convergent reflective type W21 × H33.2 × D5 W0.827 × H1.307 × D0.197	■ 1 to 31 ■ 0.039 to 1.220 ■ 1.5 to 26 ■ 0.059 to 1.024 ■ 2 to 18 ■ 0.079 to 0.709	U-LG : 1 to 30 0.039 to 1.181 LONG : 1 to 28 0.039 to 1.102 FAST : 1.5 to 24 0.059 to 0.945	3 m 9.843 ft	R25 mm R0.984 in	-20 to +250 °C -4 to +482 °F (Ordinary temperature side: -20 to +70 °C -4 to +158 °F)	FD-H25-L43	
		■ 4 to 43.5 ■ 0.157 to 1.713 ■ 5 to 42 ■ 0.197 to 1.654 ■ 6.5 to 34 ■ 0.256 to 1.339	U-LG : 4 to 43 0.157 to 1.693 LONG : 4.5 to 43 0.177 to 1.693 FAST : 5 to 40 0.197 to 1.575				FD-H25-L45	
	180 °C 356 °F • Glass substrate detection Convergent reflective type W19 × H27 × D5 W0.748 × H1.063 × D0.197	■ 60 ■ 2.362 ■ 16 ■ 0.630 ■ 2 to 6.5 ■ 0.079 to 0.256	U-LG : 32 1.260 LONG : 24 0.945 FAST : 13 0.512	2 m 6.562 ft	R18 mm R0.709 in	-60 to +180 °C -76 to +356 °F	FD-H18-L31	
		■ 880 ■ 34.646 ■ 350 ■ 13.780 ■ 65 ■ 2.559	U-LG : 640 25.197 LONG : 600 23.622 FAST : 200 7.874				FD-H13-FM2	
	Vacuum-resistant	300 °C 572 °F • Rectangular head W9.5 × H5.2 × D15 W0.374 × H0.205 × D0.591	■ 1 to 500 ■ 0.039 to 19.685 ■ 2 to 200 ■ 0.079 to 7.874 ■ 10 to 25 ■ 0.394 to 0.984	U-LG : 1 to 340 0.039 to 13.386 LONG : 1 to 270 0.039 to 10.630 FAST : 3 to 120 0.118 to 4.724	1 m 3.281 ft	R18 mm R0.709 in	-30 to +300 °C -22 to +572 °F	FD-H30-KZ1V-S (Note 3)
			300 °C 572 °F • Glass substrate detection Convergent reflective type W19 × H5 × D27 W0.748 × H0.197 × D1.063	■ 18 ■ 0.709 ■ 8 ■ 0.315 ■ 1.5 to 3 ■ 0.059 to 0.118				U-LG : 12 0.472 LONG : 10 0.394 FAST : 5.5 0.217

- Notes: 1) The sensing range is specified for white non-glossy paper (FD-H25-L43, FD-H25-L45, FD-H18-L31, FD-H30-KZ1V-S, FD-H30-L32V-S: 100 × 100 × t 0.7 mm 3.937 × 3.937 × t 0.028 in transparent glass) as the object.
 2) Note that the sensing range of the free-cut type fiber may be reduced by 20 % max. depending upon how the fiber is cut.
 3) Sold as a set comprising vacuum type fiber + photo-terminal (FV-BR1) + fiber at atmospheric side (FT-J8). Refer to P.6 for vacuum-resistant fiber set contents.

Model No. when ordering vacuum-resistant fibers individually as replacement parts

- Vacuum-resistant fiber
FD-H30-KZ1V
FD-H30-L32V
- Mounting bracket for FD-H30-KZ1V
MS-FD-2
- Photo-terminal
FV-BR1 (one pair set)
- Fiber at atmospheric side
FT-J8 (one pair set)

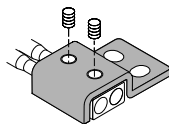

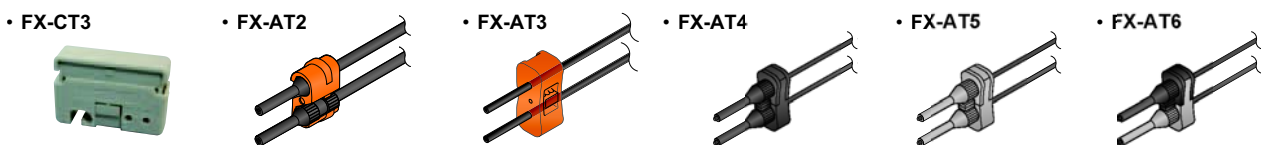
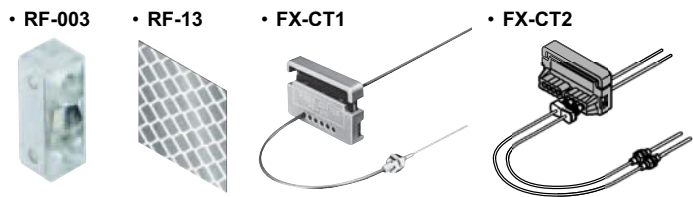

Accessories (attached with fibers)

- RF-003 (FR-KZ21/KZ21E exclusive reflector)
- RF-13 (Reflective tape)
- FX-CT1 (Fiber cutter)
- FX-CT2 (Fiber cutter)
- FX-CT3 (Fiber cutter)
- FX-AT2 (Attachment for fixed-length fiber, Orange)
- FX-AT3 (Attachment for ø2.2 mm ø0.087 in fiber, Clear orange)
- FX-AT4 (Attachment for ø1 mm ø0.039 in fiber, Black)
- FX-AT5 (Attachment for ø1.3 mm ø0.051 in fiber, Gray)
- FX-AT6 (Attachment for ø1 mm ø0.039 in / ø1.3 mm ø0.051 in mixed fiber, Black / Gray)

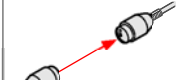

FIBER OPTIONS

Lens (For thru-beam type fiber)

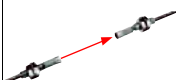
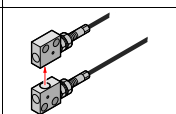
Designation	Model No.	Description																																																																																																										
For thru-beam type fiber	Expansion lens (Note 1)	<p>FX-LE1</p>  <p>Increases the sensing range by 5 times or more.</p> <ul style="list-style-type: none"> Ambient temperature: -60 to +350 °C -76 to +662 °F <p>Beam dia: ø3.6 mm ø0.142 in</p>	<p>Sensing range (mm) [Lens on both sides]</p> <table border="1"> <thead> <tr> <th>Fiber \ Mode</th> <th>HYPR</th> <th>U-LG</th> <th>LONG</th> <th>STD</th> <th>FAST</th> <th>H-SP</th> </tr> </thead> <tbody> <tr> <td>FT-B8</td> <td></td> <td></td> <td></td> <td></td> <td></td> <td></td> </tr> <tr> <td>FT-FM2</td> <td>3,600 (Note 2)</td> <td>3,600 (Note 2)</td> <td>3,600 (Note 2)</td> <td>3,600 (Note 2)</td> <td>3,600 (Note 2)</td> <td>2,000</td> </tr> <tr> <td>FT-T80</td> <td></td> <td></td> <td></td> <td></td> <td></td> <td></td> </tr> <tr> <td>FT-R80</td> <td>3,600 (Note 2)</td> <td>3,600 (Note 2)</td> <td>3,600 (Note 2)</td> <td>3,600 (Note 2)</td> <td>3,600 (Note 2)</td> <td>1,400</td> </tr> <tr> <td>FT-W8</td> <td>3,600 (Note 2)</td> <td>3,600 (Note 2)</td> <td>3,600 (Note 2)</td> <td>3,600 (Note 2)</td> <td>3,600 (Note 2)</td> <td>2,100</td> </tr> <tr> <td>FT-P80</td> <td>3,600 (Note 2)</td> <td>3,600 (Note 2)</td> <td>3,600 (Note 2)</td> <td>3,600 (Note 2)</td> <td>3,600 (Note 2)</td> <td>2,500</td> </tr> <tr> <td>FT-P60</td> <td>3,600 (Note 2)</td> <td>3,600 (Note 2)</td> <td>3,600 (Note 2)</td> <td>3,600 (Note 2)</td> <td>3,500</td> <td>1,200</td> </tr> <tr> <td>FT-P81X</td> <td>1,600 (Note 2)</td> <td>1,600 (Note 2)</td> <td>1,600 (Note 2)</td> <td>1,600 (Note 2)</td> <td>1,600 (Note 2)</td> <td>1,500</td> </tr> <tr> <td>FT-H35-M2</td> <td>3,600 (Note 2)</td> <td>3,600 (Note 2)</td> <td>3,600 (Note 2)</td> <td>3,600 (Note 2)</td> <td>3,300</td> <td>1,400</td> </tr> <tr> <td>FT-H20W-M1</td> <td>1,600 (Note 2)</td> <td>1,600 (Note 2)</td> <td>1,600 (Note 2)</td> <td>1,600 (Note 2)</td> <td>1,600 (Note 2)</td> <td>850</td> </tr> <tr> <td>FT-H20-M1</td> <td>1,600 (Note 2)</td> <td>1,600 (Note 2)</td> <td>1,600 (Note 2)</td> <td>1,600 (Note 2)</td> <td>1,600 (Note 2)</td> <td>1,200</td> </tr> <tr> <td>FT-H20-J50-S</td> <td></td> <td></td> <td></td> <td></td> <td></td> <td></td> </tr> <tr> <td>FT-H20-J30-S</td> <td>3,600 (Note 2)</td> <td>3,600 (Note 2)</td> <td>3,500</td> <td>2,000</td> <td>1,600</td> <td>500</td> </tr> <tr> <td>FT-H20-J20-S</td> <td></td> <td></td> <td></td> <td></td> <td></td> <td></td> </tr> </tbody> </table>	Fiber \ Mode	HYPR	U-LG	LONG	STD	FAST	H-SP	FT-B8							FT-FM2	3,600 (Note 2)	3,600 (Note 2)	3,600 (Note 2)	3,600 (Note 2)	3,600 (Note 2)	2,000	FT-T80							FT-R80	3,600 (Note 2)	3,600 (Note 2)	3,600 (Note 2)	3,600 (Note 2)	3,600 (Note 2)	1,400	FT-W8	3,600 (Note 2)	3,600 (Note 2)	3,600 (Note 2)	3,600 (Note 2)	3,600 (Note 2)	2,100	FT-P80	3,600 (Note 2)	3,600 (Note 2)	3,600 (Note 2)	3,600 (Note 2)	3,600 (Note 2)	2,500	FT-P60	3,600 (Note 2)	3,600 (Note 2)	3,600 (Note 2)	3,600 (Note 2)	3,500	1,200	FT-P81X	1,600 (Note 2)	1,600 (Note 2)	1,600 (Note 2)	1,600 (Note 2)	1,600 (Note 2)	1,500	FT-H35-M2	3,600 (Note 2)	3,600 (Note 2)	3,600 (Note 2)	3,600 (Note 2)	3,300	1,400	FT-H20W-M1	1,600 (Note 2)	1,600 (Note 2)	1,600 (Note 2)	1,600 (Note 2)	1,600 (Note 2)	850	FT-H20-M1	1,600 (Note 2)	1,600 (Note 2)	1,600 (Note 2)	1,600 (Note 2)	1,600 (Note 2)	1,200	FT-H20-J50-S							FT-H20-J30-S	3,600 (Note 2)	3,600 (Note 2)	3,500	2,000	1,600	500	FT-H20-J20-S						
	Fiber \ Mode	HYPR	U-LG	LONG	STD	FAST	H-SP																																																																																																					
	FT-B8																																																																																																											
	FT-FM2	3,600 (Note 2)	3,600 (Note 2)	3,600 (Note 2)	3,600 (Note 2)	3,600 (Note 2)	2,000																																																																																																					
	FT-T80																																																																																																											
FT-R80	3,600 (Note 2)	3,600 (Note 2)	3,600 (Note 2)	3,600 (Note 2)	3,600 (Note 2)	1,400																																																																																																						
FT-W8	3,600 (Note 2)	3,600 (Note 2)	3,600 (Note 2)	3,600 (Note 2)	3,600 (Note 2)	2,100																																																																																																						
FT-P80	3,600 (Note 2)	3,600 (Note 2)	3,600 (Note 2)	3,600 (Note 2)	3,600 (Note 2)	2,500																																																																																																						
FT-P60	3,600 (Note 2)	3,600 (Note 2)	3,600 (Note 2)	3,600 (Note 2)	3,500	1,200																																																																																																						
FT-P81X	1,600 (Note 2)	1,600 (Note 2)	1,600 (Note 2)	1,600 (Note 2)	1,600 (Note 2)	1,500																																																																																																						
FT-H35-M2	3,600 (Note 2)	3,600 (Note 2)	3,600 (Note 2)	3,600 (Note 2)	3,300	1,400																																																																																																						
FT-H20W-M1	1,600 (Note 2)	1,600 (Note 2)	1,600 (Note 2)	1,600 (Note 2)	1,600 (Note 2)	850																																																																																																						
FT-H20-M1	1,600 (Note 2)	1,600 (Note 2)	1,600 (Note 2)	1,600 (Note 2)	1,600 (Note 2)	1,200																																																																																																						
FT-H20-J50-S																																																																																																												
FT-H20-J30-S	3,600 (Note 2)	3,600 (Note 2)	3,500	2,000	1,600	500																																																																																																						
FT-H20-J20-S																																																																																																												
Super-expansion lens (Note 1)	<p>FX-LE2</p>  <p>Tremendously increases the sensing range with large diameter lenses.</p> <ul style="list-style-type: none"> Ambient temperature: -60 to +350 °C -76 to +662 °F <p>Beam dia: ø9.8 mm ø0.386 in</p>	<p>Sensing range (mm) [Lens on both sides]</p> <table border="1"> <thead> <tr> <th>Fiber \ Mode</th> <th>HYPR</th> <th>U-LG</th> <th>LONG</th> <th>STD</th> <th>FAST</th> <th>H-SP</th> </tr> </thead> <tbody> <tr> <td>FT-B8</td> <td></td> <td></td> <td></td> <td></td> <td></td> <td></td> </tr> <tr> <td>FT-FM2</td> <td>3,600 (Note 2)</td> <td>3,600 (Note 2)</td> <td>3,600 (Note 2)</td> <td>3,600 (Note 2)</td> <td>3,600 (Note 2)</td> <td>3,600 (Note 2)</td> </tr> <tr> <td>FT-R80</td> <td></td> <td></td> <td></td> <td></td> <td></td> <td></td> </tr> <tr> <td>FT-W8</td> <td></td> <td></td> <td></td> <td></td> <td></td> <td></td> </tr> <tr> <td>FT-P80</td> <td></td> <td></td> <td></td> <td></td> <td></td> <td></td> </tr> <tr> <td>FT-P60</td> <td></td> <td></td> <td></td> <td></td> <td></td> <td></td> </tr> <tr> <td>FT-P81X</td> <td>1,600 (Note 2)</td> <td>1,600 (Note 2)</td> <td>1,600 (Note 2)</td> <td>1,600 (Note 2)</td> <td>1,600 (Note 2)</td> <td>1,600 (Note 2)</td> </tr> <tr> <td>FT-H35-M2</td> <td>3,600 (Note 2)</td> <td>3,600 (Note 2)</td> <td>3,600 (Note 2)</td> <td>3,600 (Note 2)</td> <td>3,600 (Note 2)</td> <td>3,600 (Note 2)</td> </tr> <tr> <td>FT-H20W-M1</td> <td>1,600 (Note 2)</td> <td>1,600 (Note 2)</td> <td>1,600 (Note 2)</td> <td>1,600 (Note 2)</td> <td>1,600 (Note 2)</td> <td>1,600 (Note 2)</td> </tr> <tr> <td>FT-H20-M1</td> <td>1,600 (Note 2)</td> <td>1,600 (Note 2)</td> <td>1,600 (Note 2)</td> <td>1,600 (Note 2)</td> <td>1,600 (Note 2)</td> <td>1,600 (Note 2)</td> </tr> <tr> <td>FT-H13-FM2</td> <td>3,600 (Note 2)</td> <td>3,600 (Note 2)</td> <td>3,600 (Note 2)</td> <td>3,600 (Note 2)</td> <td>3,600 (Note 2)</td> <td>3,600 (Note 2)</td> </tr> <tr> <td>FT-H20-J50-S</td> <td></td> <td></td> <td></td> <td></td> <td></td> <td></td> </tr> <tr> <td>FT-H20-J30-S</td> <td>3,600 (Note 2)</td> <td>3,600 (Note 2)</td> <td>3,600 (Note 2)</td> <td>3,600 (Note 2)</td> <td>3,600 (Note 2)</td> <td>3,600 (Note 2)</td> </tr> <tr> <td>FT-H20-J20-S</td> <td></td> <td></td> <td></td> <td></td> <td></td> <td></td> </tr> </tbody> </table>	Fiber \ Mode	HYPR	U-LG	LONG	STD	FAST	H-SP	FT-B8							FT-FM2	3,600 (Note 2)	3,600 (Note 2)	3,600 (Note 2)	3,600 (Note 2)	3,600 (Note 2)	3,600 (Note 2)	FT-R80							FT-W8							FT-P80							FT-P60							FT-P81X	1,600 (Note 2)	1,600 (Note 2)	1,600 (Note 2)	1,600 (Note 2)	1,600 (Note 2)	1,600 (Note 2)	FT-H35-M2	3,600 (Note 2)	3,600 (Note 2)	3,600 (Note 2)	3,600 (Note 2)	3,600 (Note 2)	3,600 (Note 2)	FT-H20W-M1	1,600 (Note 2)	1,600 (Note 2)	1,600 (Note 2)	1,600 (Note 2)	1,600 (Note 2)	1,600 (Note 2)	FT-H20-M1	1,600 (Note 2)	1,600 (Note 2)	1,600 (Note 2)	1,600 (Note 2)	1,600 (Note 2)	1,600 (Note 2)	FT-H13-FM2	3,600 (Note 2)	3,600 (Note 2)	3,600 (Note 2)	3,600 (Note 2)	3,600 (Note 2)	3,600 (Note 2)	FT-H20-J50-S							FT-H20-J30-S	3,600 (Note 2)	3,600 (Note 2)	3,600 (Note 2)	3,600 (Note 2)	3,600 (Note 2)	3,600 (Note 2)	FT-H20-J20-S							
Fiber \ Mode	HYPR	U-LG	LONG	STD	FAST	H-SP																																																																																																						
FT-B8																																																																																																												
FT-FM2	3,600 (Note 2)	3,600 (Note 2)	3,600 (Note 2)	3,600 (Note 2)	3,600 (Note 2)	3,600 (Note 2)																																																																																																						
FT-R80																																																																																																												
FT-W8																																																																																																												
FT-P80																																																																																																												
FT-P60																																																																																																												
FT-P81X	1,600 (Note 2)	1,600 (Note 2)	1,600 (Note 2)	1,600 (Note 2)	1,600 (Note 2)	1,600 (Note 2)																																																																																																						
FT-H35-M2	3,600 (Note 2)	3,600 (Note 2)	3,600 (Note 2)	3,600 (Note 2)	3,600 (Note 2)	3,600 (Note 2)																																																																																																						
FT-H20W-M1	1,600 (Note 2)	1,600 (Note 2)	1,600 (Note 2)	1,600 (Note 2)	1,600 (Note 2)	1,600 (Note 2)																																																																																																						
FT-H20-M1	1,600 (Note 2)	1,600 (Note 2)	1,600 (Note 2)	1,600 (Note 2)	1,600 (Note 2)	1,600 (Note 2)																																																																																																						
FT-H13-FM2	3,600 (Note 2)	3,600 (Note 2)	3,600 (Note 2)	3,600 (Note 2)	3,600 (Note 2)	3,600 (Note 2)																																																																																																						
FT-H20-J50-S																																																																																																												
FT-H20-J30-S	3,600 (Note 2)	3,600 (Note 2)	3,600 (Note 2)	3,600 (Note 2)	3,600 (Note 2)	3,600 (Note 2)																																																																																																						
FT-H20-J20-S																																																																																																												
Side-view lens	<p>FX-SV1</p>  <p>Beam axis is bent by 90°.</p> <ul style="list-style-type: none"> Ambient temperature: -60 to +300 °C -76 to +572 °F <p>Beam dia: ø2.8 mm ø0.110 in</p>	<p>Sensing range (mm) [Lens on both sides]</p> <table border="1"> <thead> <tr> <th>Fiber \ Mode</th> <th>HYPR</th> <th>U-LG</th> <th>LONG</th> <th>STD</th> <th>FAST</th> <th>H-SP</th> </tr> </thead> <tbody> <tr> <td>FT-B8</td> <td>3,600 (Note 2)</td> <td>3,300</td> <td>2,800</td> <td>1,600</td> <td>970</td> <td>310</td> </tr> <tr> <td>FT-FM2</td> <td></td> <td></td> <td></td> <td></td> <td></td> <td></td> </tr> <tr> <td>FT-T80</td> <td>3,600 (Note 2)</td> <td>3,600 (Note 2)</td> <td>3,000</td> <td>1,700</td> <td>1,000</td> <td>330</td> </tr> <tr> <td>FT-W8</td> <td>3,600 (Note 2)</td> <td>3,500</td> <td>2,000</td> <td>1,000</td> <td>600</td> <td>250</td> </tr> <tr> <td>FT-P80</td> <td>3,600 (Note 2)</td> <td>3,500</td> <td>2,200</td> <td>1,300</td> <td>790</td> <td>290</td> </tr> <tr> <td>FT-P60</td> <td>3,500</td> <td>1,700</td> <td>1,400</td> <td>800</td> <td>500</td> <td>150</td> </tr> <tr> <td>FT-P81X</td> <td>1,600 (Note 2)</td> <td>1,600 (Note 2)</td> <td>1,600 (Note 2)</td> <td>1,400</td> <td>880</td> <td>280</td> </tr> <tr> <td>FT-H35-M2</td> <td>3,500</td> <td>1,600</td> <td>1,200</td> <td>780</td> <td>500</td> <td>150</td> </tr> <tr> <td>FT-H20W-M1</td> <td>1,600 (Note 2)</td> <td>1,600 (Note 2)</td> <td>1,500</td> <td>950</td> <td>560</td> <td>190</td> </tr> <tr> <td>FT-H20-M1</td> <td>1,600 (Note 2)</td> <td>1,600 (Note 2)</td> <td>1,300</td> <td>780</td> <td>500</td> <td>150</td> </tr> <tr> <td>FT-H20-J50-S</td> <td></td> <td></td> <td></td> <td></td> <td></td> <td></td> </tr> <tr> <td>FT-H20-J30-S</td> <td>1,600 (Note 2)</td> <td>960</td> <td>740</td> <td>450</td> <td>290</td> <td>80</td> </tr> <tr> <td>FT-H20-J20-S</td> <td></td> <td></td> <td></td> <td></td> <td></td> <td></td> </tr> </tbody> </table>	Fiber \ Mode	HYPR	U-LG	LONG	STD	FAST	H-SP	FT-B8	3,600 (Note 2)	3,300	2,800	1,600	970	310	FT-FM2							FT-T80	3,600 (Note 2)	3,600 (Note 2)	3,000	1,700	1,000	330	FT-W8	3,600 (Note 2)	3,500	2,000	1,000	600	250	FT-P80	3,600 (Note 2)	3,500	2,200	1,300	790	290	FT-P60	3,500	1,700	1,400	800	500	150	FT-P81X	1,600 (Note 2)	1,600 (Note 2)	1,600 (Note 2)	1,400	880	280	FT-H35-M2	3,500	1,600	1,200	780	500	150	FT-H20W-M1	1,600 (Note 2)	1,600 (Note 2)	1,500	950	560	190	FT-H20-M1	1,600 (Note 2)	1,600 (Note 2)	1,300	780	500	150	FT-H20-J50-S							FT-H20-J30-S	1,600 (Note 2)	960	740	450	290	80	FT-H20-J20-S														
Fiber \ Mode	HYPR	U-LG	LONG	STD	FAST	H-SP																																																																																																						
FT-B8	3,600 (Note 2)	3,300	2,800	1,600	970	310																																																																																																						
FT-FM2																																																																																																												
FT-T80	3,600 (Note 2)	3,600 (Note 2)	3,000	1,700	1,000	330																																																																																																						
FT-W8	3,600 (Note 2)	3,500	2,000	1,000	600	250																																																																																																						
FT-P80	3,600 (Note 2)	3,500	2,200	1,300	790	290																																																																																																						
FT-P60	3,500	1,700	1,400	800	500	150																																																																																																						
FT-P81X	1,600 (Note 2)	1,600 (Note 2)	1,600 (Note 2)	1,400	880	280																																																																																																						
FT-H35-M2	3,500	1,600	1,200	780	500	150																																																																																																						
FT-H20W-M1	1,600 (Note 2)	1,600 (Note 2)	1,500	950	560	190																																																																																																						
FT-H20-M1	1,600 (Note 2)	1,600 (Note 2)	1,300	780	500	150																																																																																																						
FT-H20-J50-S																																																																																																												
FT-H20-J30-S	1,600 (Note 2)	960	740	450	290	80																																																																																																						
FT-H20-J20-S																																																																																																												
Expansion lens for vacuum fiber (Note 1)	<p>FV-LE1</p>  <p>Sensing range increases by 4 times or more.</p> <ul style="list-style-type: none"> Ambient temperature: -60 to +350 °C -76 to +662 °F <p>Beam dia: ø3.6 mm ø0.142 in</p>	<p>Sensing range (mm) [Lens on both sides] (Note 3)</p> <table border="1"> <thead> <tr> <th>Fiber \ Mode</th> <th>HYPR</th> <th>U-LG</th> <th>LONG</th> <th>STD</th> <th>FAST</th> <th>H-SP</th> </tr> </thead> <tbody> <tr> <td>FT-H30-M1V</td> <td>3,600 (Note 2)</td> <td>3,600 (Note 2)</td> <td>3,400</td> <td>1,500</td> <td>900</td> <td>370</td> </tr> </tbody> </table>	Fiber \ Mode	HYPR	U-LG	LONG	STD	FAST	H-SP	FT-H30-M1V	3,600 (Note 2)	3,600 (Note 2)	3,400	1,500	900	370																																																																																												
Fiber \ Mode	HYPR	U-LG	LONG	STD	FAST	H-SP																																																																																																						
FT-H30-M1V	3,600 (Note 2)	3,600 (Note 2)	3,400	1,500	900	370																																																																																																						
Vacuum-resistant side-view lens (Note 1)	<p>FV-SV2</p>  <p>Beam axis is bent by 90°.</p> <ul style="list-style-type: none"> Ambient temperature: -60 to +300 °C -76 to +572 °F <p>Beam dia: ø3.7 mm ø0.146 in</p>	<p>Sensing range (mm) [Lens on both sides] (Note 3)</p> <table border="1"> <thead> <tr> <th>Fiber \ Mode</th> <th>HYPR</th> <th>U-LG</th> <th>LONG</th> <th>STD</th> <th>FAST</th> <th>H-SP</th> </tr> </thead> <tbody> <tr> <td>FT-H30-M1V</td> <td>3,600 (Note 2)</td> <td>3,600 (Note 2)</td> <td>3,400</td> <td>1,500</td> <td>900</td> <td>370</td> </tr> </tbody> </table>	Fiber \ Mode	HYPR	U-LG	LONG	STD	FAST	H-SP	FT-H30-M1V	3,600 (Note 2)	3,600 (Note 2)	3,400	1,500	900	370																																																																																												
Fiber \ Mode	HYPR	U-LG	LONG	STD	FAST	H-SP																																																																																																						
FT-H30-M1V	3,600 (Note 2)	3,600 (Note 2)	3,400	1,500	900	370																																																																																																						

- Notes: 1) Be careful when installing the thru-beam type fiber equipped with the expansion lens, as the beam envelope becomes narrow and alignment is difficult. Especially when installing a fiber with many cores (sharp bending fibers and heat-resistant glass fiber), please be sure to use it only after you have adjusted it sufficiently.
- 2) The fiber cable length practically limits the sensing range to 3,600 mm 141.732 in long (FT-P81X, FT-H20W-M1 and FT-H20-M1: 1,600 mm 62.992 in).
- 3) The fiber cable length for the FT-H30-M1V is 1 m 3.281 ft. The sensing ranges in HYPR, U-LG and LONG modes take into account the length of the FT-J8 atmospheric side fiber.

FIBER OPTIONS

Lens (For reflective type fiber)

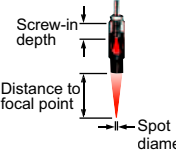
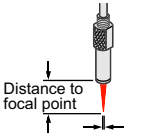
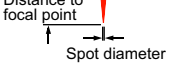
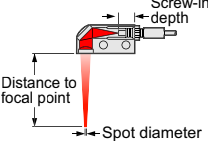
Designation	Model No.	Description															
For reflective type fiber	Pinpoint spot lens	FX-MR1	 <p>Pinpoint spot of $\varnothing 0.5$ mm $\varnothing 0.020$ in. Enables detection of minute objects or small marks.</p> <ul style="list-style-type: none"> Distance to focal point: 6 ± 1 mm 0.236 ± 0.039 in Applicable fibers: FD-WG4, FD-G4 Ambient temperature: -40 to $+70$ °C -40 to $+158$ °F 														
	Zoom lens	FX-MR2	 <p>The spot diameter is adjustable from $\varnothing 0.7$ to $\varnothing 2$ mm $\varnothing 0.028$ to $\varnothing 0.079$ in according to how much the fiber is screwed in.</p> <ul style="list-style-type: none"> Applicable fibers: FD-WG4, FD-G4 Ambient temperature: -40 to $+70$ °C -40 to $+158$ °F Accessory: MS-EX-3 (mounting bracket) <p>Sensing range</p> <table border="1"> <thead> <tr> <th>Screw-in depth</th> <th>Distance to focal point</th> <th>Spot diameter</th> </tr> </thead> <tbody> <tr> <td>7mm</td> <td>18.5 mm approx.</td> <td>$\varnothing 0.7$ mm</td> </tr> <tr> <td>12mm</td> <td>27 mm approx.</td> <td>$\varnothing 1.2$ mm</td> </tr> <tr> <td>14mm</td> <td>43 mm approx.</td> <td>$\varnothing 2.0$ mm</td> </tr> </tbody> </table>	Screw-in depth	Distance to focal point	Spot diameter	7mm	18.5 mm approx.	$\varnothing 0.7$ mm	12mm	27 mm approx.	$\varnothing 1.2$ mm	14mm	43 mm approx.	$\varnothing 2.0$ mm		
	Screw-in depth	Distance to focal point	Spot diameter														
	7mm	18.5 mm approx.	$\varnothing 0.7$ mm														
	12mm	27 mm approx.	$\varnothing 1.2$ mm														
14mm	43 mm approx.	$\varnothing 2.0$ mm															
Finest spot lens	FX-MR3	 <p>Extremely fine spot of $\varnothing 0.3$ mm $\varnothing 0.012$ in approx. achieved.</p> <ul style="list-style-type: none"> Applicable fibers: FD-WG4, FD-G4, FD-EG1, FD-EG2, FD-EG3, FD-G6X, FD-G6 Ambient temperature: -40 to $+70$ °C -40 to $+158$ °F <p>Sensing range</p> <table border="1"> <thead> <tr> <th>Fiber model No.</th> <th>Distance to focal point</th> <th>Spot diameter</th> </tr> </thead> <tbody> <tr> <td>FD-EG3</td> <td>7.5 ± 0.5 mm</td> <td>$\varnothing 0.15$ mm approx.</td> </tr> <tr> <td>FD-EG2</td> <td>7.5 ± 0.5 mm</td> <td>$\varnothing 0.2$ mm approx.</td> </tr> <tr> <td>FD-EG1</td> <td>7.5 ± 0.5 mm</td> <td>$\varnothing 0.3$ mm approx.</td> </tr> <tr> <td>FD-WG4/G4/G6X/G6</td> <td>7.5 ± 0.5 mm</td> <td>$\varnothing 0.5$ mm approx.</td> </tr> </tbody> </table>	Fiber model No.	Distance to focal point	Spot diameter	FD-EG3	7.5 ± 0.5 mm	$\varnothing 0.15$ mm approx.	FD-EG2	7.5 ± 0.5 mm	$\varnothing 0.2$ mm approx.	FD-EG1	7.5 ± 0.5 mm	$\varnothing 0.3$ mm approx.	FD-WG4/G4/G6X/G6	7.5 ± 0.5 mm	$\varnothing 0.5$ mm approx.
Fiber model No.	Distance to focal point	Spot diameter															
FD-EG3	7.5 ± 0.5 mm	$\varnothing 0.15$ mm approx.															
FD-EG2	7.5 ± 0.5 mm	$\varnothing 0.2$ mm approx.															
FD-EG1	7.5 ± 0.5 mm	$\varnothing 0.3$ mm approx.															
FD-WG4/G4/G6X/G6	7.5 ± 0.5 mm	$\varnothing 0.5$ mm approx.															
Finest spot lens	FX-MR6	 <p>Extremely fine spot of $\varnothing 0.1$ mm $\varnothing 0.004$ in approx. achieved.</p> <ul style="list-style-type: none"> Applicable fibers: FD-WG4, FD-G4, FD-EG1, FD-EG2, FD-EG3, FD-G6X, FD-G6 Ambient temperature: -20 to $+60$ °C -4 to $+140$ °F <p>Sensing range</p> <table border="1"> <thead> <tr> <th>Fiber model No.</th> <th>Distance to focal point</th> <th>Spot diameter</th> </tr> </thead> <tbody> <tr> <td>FD-EG3</td> <td>7 ± 0.5 mm</td> <td>$\varnothing 0.1$ mm approx.</td> </tr> <tr> <td>FD-EG2</td> <td>7 ± 0.5 mm</td> <td>$\varnothing 0.15$ mm approx.</td> </tr> <tr> <td>FD-EG1</td> <td>7 ± 0.5 mm</td> <td>$\varnothing 0.2$ mm approx.</td> </tr> <tr> <td>FD-WG4/G4/G6X/G6</td> <td>7 ± 0.5 mm</td> <td>$\varnothing 0.4$ mm approx.</td> </tr> </tbody> </table>	Fiber model No.	Distance to focal point	Spot diameter	FD-EG3	7 ± 0.5 mm	$\varnothing 0.1$ mm approx.	FD-EG2	7 ± 0.5 mm	$\varnothing 0.15$ mm approx.	FD-EG1	7 ± 0.5 mm	$\varnothing 0.2$ mm approx.	FD-WG4/G4/G6X/G6	7 ± 0.5 mm	$\varnothing 0.4$ mm approx.
Fiber model No.	Distance to focal point	Spot diameter															
FD-EG3	7 ± 0.5 mm	$\varnothing 0.1$ mm approx.															
FD-EG2	7 ± 0.5 mm	$\varnothing 0.15$ mm approx.															
FD-EG1	7 ± 0.5 mm	$\varnothing 0.2$ mm approx.															
FD-WG4/G4/G6X/G6	7 ± 0.5 mm	$\varnothing 0.4$ mm approx.															
Zoom lens (side-view type)	FX-MR5	 <p>FX-MR2 is converted into a side-view type and can be mounted in a very small space.</p> <ul style="list-style-type: none"> Applicable fibers: FD-WG4, FD-G4 Ambient temperature: -40 to $+70$ °C -40 to $+158$ °F <p>Sensing range</p> <table border="1"> <thead> <tr> <th>Screw-in depth</th> <th>Distance to focal point</th> <th>Spot diameter</th> </tr> </thead> <tbody> <tr> <td>8 mm</td> <td>13 mm approx.</td> <td>$\varnothing 0.5$ mm</td> </tr> <tr> <td>10 mm</td> <td>15 mm approx.</td> <td>$\varnothing 0.8$ mm</td> </tr> <tr> <td>14 mm</td> <td>30 mm approx.</td> <td>$\varnothing 3.0$ mm</td> </tr> </tbody> </table>	Screw-in depth	Distance to focal point	Spot diameter	8 mm	13 mm approx.	$\varnothing 0.5$ mm	10 mm	15 mm approx.	$\varnothing 0.8$ mm	14 mm	30 mm approx.	$\varnothing 3.0$ mm			
Screw-in depth	Distance to focal point	Spot diameter															
8 mm	13 mm approx.	$\varnothing 0.5$ mm															
10 mm	15 mm approx.	$\varnothing 0.8$ mm															
14 mm	30 mm approx.	$\varnothing 3.0$ mm															

FIBER OPTIONS

Designation	Model No.	Description		
Protective tube (For thru-beam type fiber)	FTP-500 (0.5 m 1.640 ft)	For M4 thread	FT-B8 FT-P80 FT-FM2 FT-P60 FT-FM2S FT-FM2S4	
	FTP-1000 (1 m 3.281 ft)			
	FTP-1500 (1.5 m 4.921 ft)			
	FTP-N500 (0.5 m 1.640 ft)	For M3 thread	FT-T80 FT-P40 FT-NFM2 FD-T40 FT-NFM2S FD-P40 FT-NFM2S4	
	FTP-N1000 (1 m 3.281 ft)			
	FTP-N1500 (1.5 m 4.921 ft)			
Protective tube (For reflective type fiber)	FDP-500 (0.5 m 1.640 ft)	For M6 thread	FD-B8 FD-P80 FD-FM2 FD-H13-FM2 FD-FM2S FD-FM2S4	
	FDP-1000 (1 m 3.281 ft)			
	FDP-1500 (1.5 m 4.921 ft)			
	FDP-N500 (0.5 m 1.640 ft)	For M4 thread	FD-T80 FD-NFM2 FD-NFM2S FD-NFM2S4	
	FDP-N1000 (1 m 3.281 ft)			
	FDP-N1500 (1.5 m 4.921 ft)			
Fiber bender	FB-1	The fiber bender bends the sleeve part of the fiber head at the proper radius. (Note 1)		
Universal sensor mounting stand (Note 2)	MS-AJ1-F	Horizontal mounting type	Mounting stand assembly for fiber (For M3, M4 or M6 threaded head fiber)	
	MS-AJ2-F	Vertical mounting type		
Resin nut set	FX-M6N	Applicable fibers	FD-G60	For 10 set of resin M6 nuts and flat washers
	FX-M4N		FT-F41 FD-G40	For 10 set of resin M4 nuts and flat washers
Liquid inflow prevention joint (Note 2)	MS-FX-01Y	Applicable fibers	FD-HF40Y FD-F41Y	This joint suppresses false operations due to liquid slip-in from the top of the protective tube.
Protective tube extension joint (Note 2)	MS-FX-02Y			The protective tube can be extended.
Fiber mounting joint (Note 2)	MS-FX-03Y			The joint is used for mounting fibers on a tank.
Single-core holder	FX-AT15A			The incident light intensity may vary when using a multi-core fiber or a thin type sharp bending fiber. This holder suppresses the variation in the incident light intensity.

Notes: 1) Do not bend the sleeve part of any side-view type fiber or ultra-small diameter head type fiber.
 2) The joint internal ferrule (MS-FX-YF) is available as a spare part. A distorted ferrule may result in leakage.

Protective tube

- FTP-□
- FDP-□



Fiber bender

- FB-1

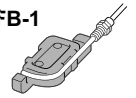

Universal sensor mounting stand

Using the arm which enables adjustment in the horizontal direction, detection can also be done from above an assembly line.

- MS-AJ1-F 360° rotation

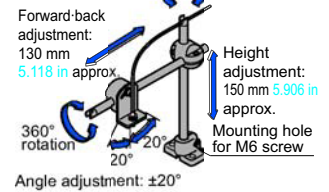

- MS-AJ2-F 360° rotation

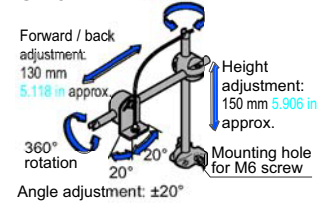

Liquid inflow prevention joint

- MS-FX-01Y

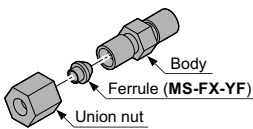

Protective tube extension joint

- MS-FX-02Y

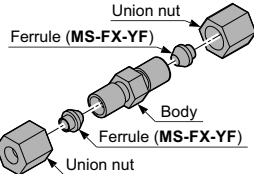

Fiber mounting joint

- MS-FX-03Y

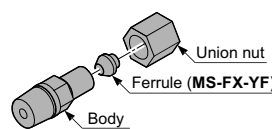

Single-core holder

- FX-AT15A



PRECAUTIONS FOR PROPER USE



- Never use this product as a sensing device for personnel protection.
- In case of using sensing devices for personnel protection, use products which meet laws and standards, such as OSHA, ANSI or IEC etc., for personnel protection applicable in each region or country.

Wiring

- Make sure that the power supply is OFF while adding or removing the amplifiers.
- Note that if a voltage exceeding the rated range is applied, or if an AC power supply is directly connected, the product may get burnt or damaged.
- Note that short-circuit of the load or wrong wiring may burn or damage the product.
- Do not run the wires together with high-voltage lines or power lines, or put them in the same raceway. This can cause malfunction due to induction.
- Verify that the supply voltage variation is within the rating.
- If power is supplied from a commercial switching regulator, ensure that the frame ground (F.G.) terminal of the power supply is connected to an actual ground.
- In case noise generating equipment (switching regulator, inverter motor, etc.) is used in the vicinity of this product, connect the frame ground (F.G.) terminal of the equipment to an actual ground.
- Make sure to use the quick-connection cable (optional) for the connection of the controller.
Extension up to total 100 m 328.084 ft is possible with 0.3 mm² or more, cable.
However, in order to reduce noise, make the wiring as short as possible.
- Make sure that stress by forcible bending or pulling is not applied to the sensor cable joint and fiber cable.

Others

- This product has been developed / produced for industrial use only.
- The specification may not be satisfied in a strong magnetic field.
- The ultra long distance (U-LG, HYPR) mode is more likely to be affected by extraneous noise since the sensitivity of that is higher than the other modes. Make sure to check the environment before use.
- Do not use during the initial transient time (H-SP, FAST, STD: 0.5 sec., LONG, U-LG, HYPR: 1 sec.) after the power supply is switched ON.
- This product is suitable for indoor use only.
- Avoid dust, dirt, and steam.
- Make sure that the product does not come in contact with oil, grease, organic solvents such as thinner, etc., strong acid or alkaline.
- This product cannot be used in an environment containing inflammable or explosive gases.
- Never disassemble or modify this product.
- This product adopts EEPROM. Settings cannot be done 100 thousand times or more because of the EEPROM's lifetime.

Disclaimer

The applications described in the catalog are all intended for examples only.
The purchase of our products described in the catalog shall not be regarded as granting of a license to use our products in the described applications.
We do NOT warrant that we have obtained some intellectual properties, such as patent rights, with respect to such applications, or that the described applications may not infringe any intellectual property rights, such as patent rights, of a third party.

DIMENSIONS (Unit: mm in)

Super quality fibers • Thru-beam type



FT-30

<with FX-AT2>

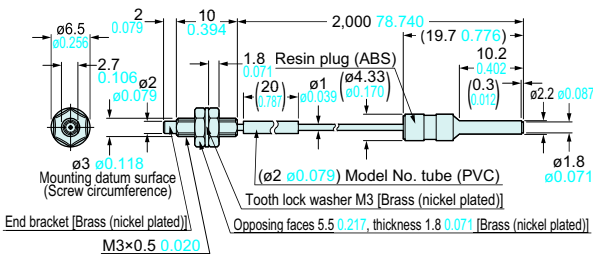

FT-40

<with FX-AT2>

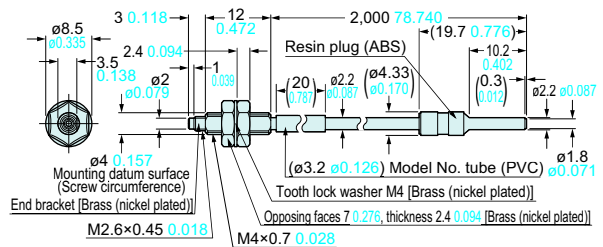

FT-S20

<with FX-AT2>

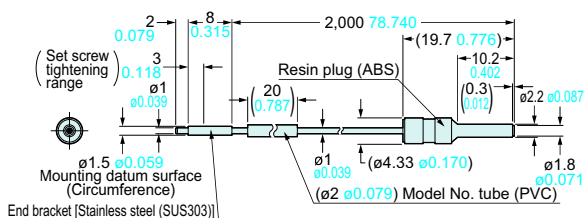

FT-S30

<with FX-AT2>

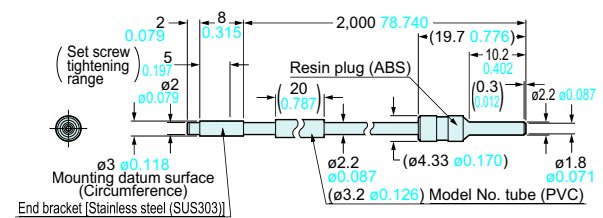

DIMENSIONS (Unit: mm in)

CN-73-C □ CN-74-C □ Main cable (Optional)

• Length L

Model No.	Length L
CN-73/74-C1	1,000 39.370
CN-73/74-C2	2,000 78.740
CN-73/74-C5	5,000 196.850

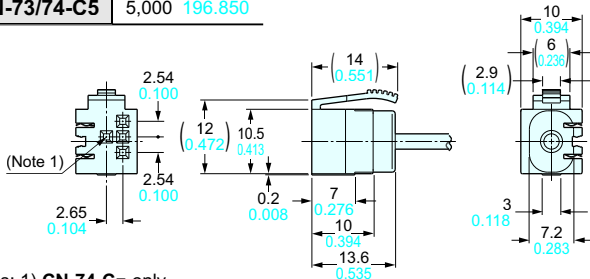
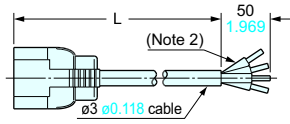

Notes: 1) CN-74-C □ only
2) CN-73-C □: 3-core

CN-71-C □ CN-72-C □ Sub cable (Optional)

• Length L

Model No.	Length L
CN-71/72-C1	1,000 39.370
CN-71/72-C2	2,000 78.740
CN-71/72-C5	5,000 196.850

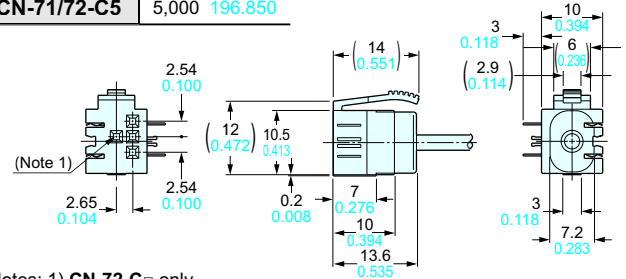
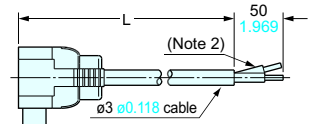

Notes: 1) CN-72-C □ only
2) CN-71-C □: 1-core

MS-DIN-2 Amplifier mounting bracket (Optional)

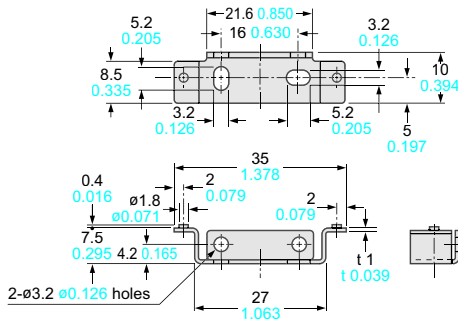

Material: Cold rolled carbon steel (SPCC)
(Uni-chrome plated)

MS-DIN-E End plate (Optional)

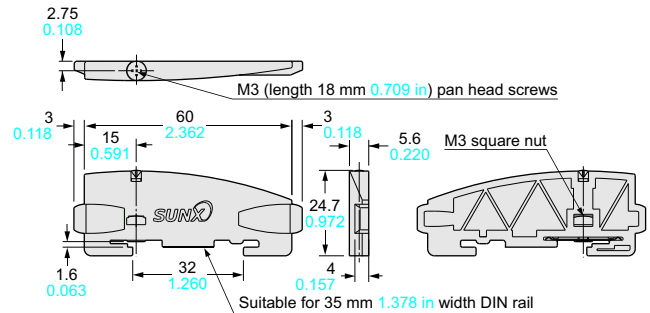

Material: Polycarbonate

<Fiber Sensor Lineup>

Digital fiber sensor FX-100 series

- The digital dual-display is greatly visible in the workplace!
- Commercially-available connectors are used so that lead time and spare part numbers can both be reduced.



Digital fiber sensor (Manually set) FX-410 series

- Simple operation that does not require users to read instruction manuals.
- The beam power has been greatly increased.



All information is subject to change without prior notice.



SUNX Limited

2431-1 Ushiyama-cho, Kasugai-shi, Aichi,
486-0901, Japan
Phone: +81-568-33-7211
FAX: +81-568-33-2631

Overseas Sales Division

Phone: +81-568-33-7861
FAX: +81-568-33-8591

<http://www.sunx.com>