

SGDV-□

Sigma-5 servo drive

The High performance servo family for motion control. Compact size, reduced space and integrated MECHATROLINK-II.

- Advance autotuning function
- Enhanced vibration suppression function
- Standard support for analog voltage/pulse train reference series or MECHATROLINK-II communications reference series.
- Support for direct drive servomotors, linear servomotors and linear sliders
- Integrated safety stop function
- Oscilloscope available via software tool
- Windows based configuration and commissioning software

Ratings

- 230 VAC Single-phase 50 W to 1.5 kW (4.77 Nm)
- 400 VAC Three-phase 500 W to 15 kW (95.4 Nm)



System configuration

(Refer to chapter Sigma-II rotary motors)

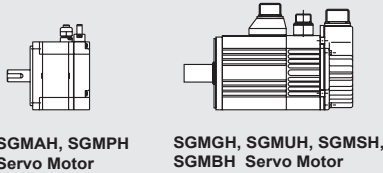

(Refer to chapter Sigma-5 rotary motors)

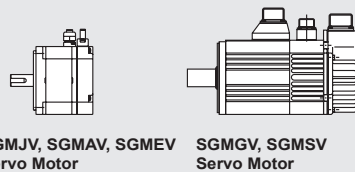

(Refer to chapter Sigma linear motors)

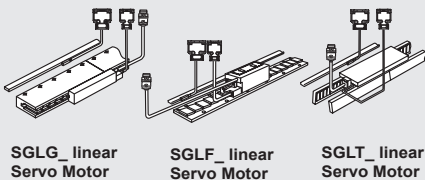

(Refer to chapter Sigma direct drive motors)

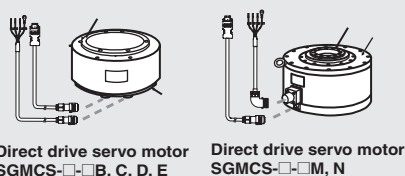



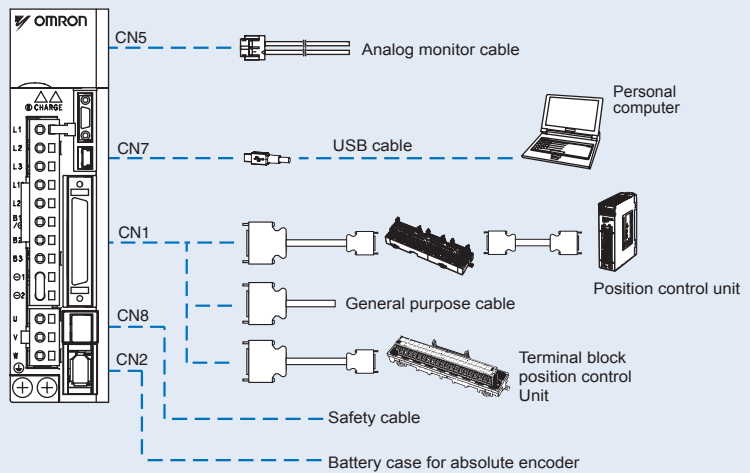



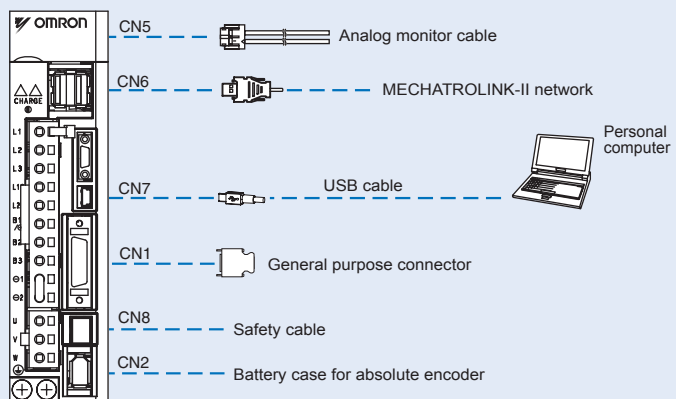

Sigma-5 Analog/Pulse Reference Servo Drive







Sigma-5 MECHATROLINK-II Servo Drive



Servo motor / servo drive combination

Servo motor				Sigma-5 Servo drive			
Family	Voltage	Rated torque	Capacity	230 V (1 phase) Analog/Pulse	230 V (1 phase) MECHATROLINK-II	400 V (3 phase) Analog/Pulse	400 V (3 phases) MECHATROLINK-II
Sigma-II series motors (refer to the Sigma-II rotary motors chapter for details)							
 SGMAH (3000 min ⁻¹)	230 V	0.0955 Nm	30 W	SGDV-A5A01A-OY	SGDV-A5A11A-OY	-	-
		0.159 Nm	50 W	SGDV-A5A01A-OY	SGDV-A5A11A-OY	-	-
		0.318 Nm	100 W	SGDV-01A01A-OY	SGDV-01A11A-OY	-	-
		0.637 Nm	200 W	SGDV-02A01A-OY	SGDV-02A11A-OY	-	-
		1.27 Nm	400 W	SGDV-04A01A-OY	SGDV-04A11A-OY	-	-
	2.39 Nm	750 W	SGDV-08A01A-OY	SGDV-08A11A-OY	-	-	
	400 V	0.955 Nm	300 W	-	-	SGDV-05D01A-OY	SGDV-05D11A-OY
2.07 Nm		650 W	-	-	SGDV-10D01A-OY	SGDV-10D11A-OY	
 SGMPH (3000 min ⁻¹)	230 V	0.318 Nm	100 W	SGDV-01A01A-OY	SGDV-01A11A-OY	-	-
		0.637 Nm	200 W	SGDV-02A01A-OY	SGDV-02A11A-OY	-	-
		1.27 Nm	400 W	SGDV-04A01A-OY	SGDV-04A11A-OY	-	-
		2.39 Nm	750 W	SGDV-08A01A-OY	SGDV-08A11A-OY	-	-
		4.77 Nm	1500 W	SGDV-15A01A-OY-008000	SGDV-15A11A-OY-008000	-	-
	400 V	0.637 Nm	200 W	-	-	SGDV-05D01A-OY	SGDV-05D11A-OY
		1.27 Nm	400 W	-	-	SGDV-05D01A-OY	SGDV-05D11A-OY
 SGMGH (1500 min ⁻¹)	400 V	2.84 Nm	0.45 kW	-	-	SGDV-05D01A-OY	SGDV-05D11A-OY
		5.39 Nm	0.85 kW	-	-	SGDV-10D01A-OY	SGDV-10D11A-OY
		8.34 Nm	1.3 kW	-	-	SGDV-15D01A-OY	SGDV-15D11A-OY
		11.5 Nm	1.8 kW	-	-	SGDV-20D01A-OY	SGDV-20D11A-OY
		18.6 Nm	2.9 kW	-	-	SGDV-30D01A-OY	SGDV-30D11A-OY
		28.4 Nm	4.4 kW	-	-	SGDV-50D01A-OY	SGDV-50D11A-OY
		35.0 Nm	5.5 kW	-	-	SGDV-210D01A	SGDV-210D11A
		48.0 Nm	7.5 kW	-	-	SGDV-260D01A	SGDV-260D11A
		70.0 Nm	11 kW	-	-	SGDV-280D01A	SGDV-280D11A
		95.4 Nm	15 kW	-	-	SGDV-370D01A	SGDV-370D11A
 SGMSH (3000 min ⁻¹)	400 V	3.18 Nm	1.0 kW	-	-	SGDV-10D01A-OY	SGDV-10D11A-OY
		4.90 Nm	1.5 kW	-	-	SGDV-15D01A-OY	SGDV-15D11A-OY
		6.36 Nm	2.0 kW	-	-	SGDV-20D01A-OY	SGDV-20D11A-OY
		9.80 Nm	3.0 kW	-	-	SGDV-30D01A-OY	SGDV-30D11A-OY
		12.6 Nm	4.0 kW	-	-	SGDV-50D01A-OY	SGDV-50D11A-OY
 SGMUH (6000 min ⁻¹)	400 V	1.59 Nm	1.0 kW	-	-	SGDV-10D01A-OY	SGDV-10D11A-OY
		2.45 Nm	1.5 kW	-	-	SGDV-15D01A-OY	SGDV-15D11A-OY
		4.9 Nm	3.0 kW	-	-	SGDV-30D01A-OY	SGDV-30D11A-OY
		6.3 Nm	4.0 kW	-	-	SGDV-50D01A-OY	SGDV-50D11A-OY
Sigma-5 series motors (refer to the Sigma-5 rotary motors chapter for details)							
 SGMJV (3000 min ⁻¹)	230 V	0.159 Nm	50 W	SGDV-A5A01A-OY	SGDV-A5A11A-OY	-	-
		0.318 Nm	100 W	SGDV-01A01A-OY	SGDV-01A11A-OY	-	-
		0.637 Nm	200 W	SGDV-02A01A-OY	SGDV-02A11A-OY	-	-
		1.27 Nm	400 W	SGDV-04A01A-OY	SGDV-04A11A-OY	-	-
		2.39 Nm	750 W	SGDV-08A01A-OY	SGDV-08A11A-OY	-	-
 SGMAV (3000 min ⁻¹)	230 V	0.159 Nm	50 W	SGDV-A5A01A-OY	SGDV-A5A11A-OY	-	-
		0.318 Nm	100 W	SGDV-01A01A-OY	SGDV-01A11A-OY	-	-
		0.477 Nm	150 W	SGDV-02A01A-OY	SGDV-02A11A-OY	-	-
		0.637 Nm	200 W	SGDV-02A01A-OY	SGDV-02A11A-OY	-	-
		1.27 Nm	400 W	SGDV-04A01A-OY	SGDV-04A11A-OY	-	-
		1.75 Nm	550 W	SGDV-08A01A-OY	SGDV-08A11A-OY	-	-
		2.39 Nm	750 W	SGDV-08A01A-OY	SGDV-08A11A-OY	-	-
 SGMEV (3000 min ⁻¹)	230 V	3.18 Nm	1.0 kW	SGDV-15A01A-OY-008000	SGDV-15A11A-OY-008000	-	-
		0.318 Nm	100 W	SGDV-01A01A-OY	SGDV-01A11A-OY	-	-
		0.637 Nm	200 W	SGDV-02A01A-OY	SGDV-02A11A-OY	-	-
		1.27 Nm	400 W	SGDV-04A01A-OY	SGDV-04A11A-OY	-	-
		2.39 Nm	750 W	SGDV-08A01A-OY	SGDV-08A11A-OY	-	-
	4.77 Nm	1.5 kW	SGDV-15A01A-OY-008000	SGDV-15A11A-OY-008000	-	-	
	400 V	0.637 Nm	200 W	-	-	SGDV-05D01A-OY	SGDV-05D11A-OY
		0.955 Nm	300 W	-	-	SGDV-05D01A-OY	SGDV-05D11A-OY
1.27 Nm		400 W	-	-	SGDV-05D01A-OY	SGDV-05D11A-OY	
 SGMEV (3000 min ⁻¹)	400 V	2.07 Nm	650 W	-	-	SGDV-10D01A-OY	SGDV-10D11A-OY
		2.39 Nm	750 W	-	-	SGDV-10D01A-OY	SGDV-10D11A-OY
		4.77 Nm	1.5 kW	-	-	SGDV-15D01A-OY	SGDV-15D11A-OY
		4.77 Nm	1.5 kW	-	-	SGDV-15D01A-OY	SGDV-15D11A-OY

Servo motor				Sigma-5 Servo drive			
Family	Voltage	Rated torque	Capacity	230 V (1 phase) Analog/Pulse	230 V (1 phase) MECHATROLINK-II	400 V (3 phase) Analog/Pulse	400 V (3 phases) MECHATROLINK-II
 SGMGV (1500 min ⁻¹)	400 V	1.96 Nm	300 W	-	-	SGDV-05D01A-OY	SGDV-05D11A-OY
		2.86 Nm	450 W	-	-	SGDV-05D01A-OY	SGDV-05D11A-OY
		5.39 Nm	850 W	-	-	SGDV-10D01A-OY	SGDV-10D11A-OY
		8.34 Nm	1.3 kW	-	-	SGDV-15D01A-OY	SGDV-15D11A-OY
		11.5 Nm	1.8 kW	-	-	SGDV-20D01A-OY	SGDV-20D11A-OY
		18.6 Nm	2.9 kW	-	-	SGDV-30D01A-OY	SGDV-30D11A-OY
		28.4 Nm	4.4 kW	-	-	SGDV-50D01A-OY	SGDV-50D11A-OY
		35.0 Nm	5.5 Kw	-	-	SGDV-210D01A	SGDV-210D11A
		48.0 Nm	7.5 Kw	-	-	SGDV-260D01A	SGDV-260D11A
		70.0 Nm	11 Kw	-	-	SGDV-280D01A	SGDV-280D11A
SGM5V (3000 min ⁻¹)	400 V	3.18 Nm	1 kW	-	-	SGDV-10D01A-OY	SGDV-10D11A-OY
		4.9 Nm	1.5 kW	-	-	SGDV-15D01A-OY	SGDV-15D11A-OY
		6.36 Nm	2 kW	-	-	SGDV-20D01A-OY	SGDV-20D11A-OY
		7.96 Nm	2.5 kW	-	-	SGDV-30D01A-OY	SGDV-30D11A-OY
		9.8 Nm	3 kW	-	-	SGDV-30D01A-OY	SGDV-30D11A-OY
		12.6 Nm	4 kW	-	-	SGDV-50D01A-OY	SGDV-50D11A-OY
		15.8 Nm	5 kW	-	-	SGDV-50D01A-OY	SGDV-50D11A-OY
Sigma direct drive motors (refer to the Sigma direct drive motors chapter for details)							
 SGMCS (200 min ⁻¹)	230 V	2.0 Nm	42 W	SGDV-04A01A-OY	SGDV-04A11A-OY	-	-
		5.0 Nm	105 W	SGDV-04A01A-OY	SGDV-04A11A-OY	-	-
		7.0 Nm	147 W	SGDV-02A01A-OY	SGDV-02A11A-OY	-	-
		4.0 Nm	84 W	SGDV-04A01A-OY	SGDV-04A11A-OY	-	-
		10.0 Nm	209 W	SGDV-04A01A-OY	SGDV-04A11A-OY	-	-
		14.0 Nm	293 W	SGDV-04A01A-OY	SGDV-04A11A-OY	-	-
		8.0 Nm	168 W	SGDV-04A01A-OY	SGDV-04A11A-OY	-	-
		17.0 Nm	356 W	SGDV-04A01A-OY	SGDV-04A11A-OY	-	-
		25.0 Nm	393 W	SGDV-04A01A-OY	SGDV-04A11A-OY	-	-
		16.0 Nm	335 W	SGDV-08A01A-OY	SGDV-08A11A-OY	-	-
		35.0 Nm	550 W	SGDV-08A01A-OY	SGDV-08A11A-OY	-	-
		45.0Nm	707 W	SGDV-15A01A-OY-008000	SGDV-15A11A-OY-008000	-	-
		80.0 Nm	1260 W	SGDV-15A01A-OY-008000	SGDV-15A11A-OY-008000	-	-
Sigma linear motors (refer to the Sigma linear motors chapter for details)							
 SGLGW coreless standard-force magnetic ways	230 V	12.5 N (40 N peak)	-	SGDV-A5A05A-OY	SGDV-A5A15A-OY	-	-
		25 N (80 N peak)	-	SGDV-01A05A-OY	SGDV-01A15A-OY	-	-
		47 N (140 N peak)	-	SGDV-01A05A-OY	SGDV-01A15A-OY	-	-
		70 N (220 N peak)	-	SGDV-02A05A-OY	SGDV-02A15A-OY	-	-
		93 N (280 N peak)	-	SGDV-02A05A-OY	SGDV-02A15A-OY	-	-
		140 N (420 N peak)	-	SGDV-04A05A-OY	SGDV-04A15A-OY	-	-
		140 N (440 N peak)	-	SGDV-04A05A-OY	SGDV-04A15A-OY	-	-
		210 N (660 N peak)	-	SGDV-08A05A-OY	SGDV-08A15A-OY	-	-
325 N (1300 N peak)	-	SGDV-15A05A-OY-008000	SGDV-15A15A-OY-008000	-	-		
 SGLGW coreless high-force magnetic ways	230 V	57 N (230 N peak)	-	SGDV-02A05A-OY	SGDV-02A15A-OY	-	-
		114 N (460 N peak)	-	SGDV-02A05A-OY	SGDV-02A15A-OY	-	-
		171 N (690 N peak)	-	SGDV-08A05A-OY	SGDV-08A15A-OY	-	-
		85 N (360 N peak)	-	SGDV-02A05A-OY	SGDV-02A15A-OY	-	-
		170 N (720 N peak)	-	SGDV-08A05A-OY	SGDV-08A15A-OY	-	-
255 N (1080 N peak)	-	SGDV-08A05A-OY	SGDV-08A15A-OY	-	-		
 SGLFW Linear motors	230 V	25 N (86 N peak)	-	SGDV-02A05A-OY	SGDV-02A15A-OY	-	-
		40 N (125 N peak)	-	SGDV-01A05A-OY	SGDV-01A15A-OY	-	-
		80 N (220 N peak)	-	SGDV-02A05A-OY	SGDV-02A15A-OY	-	-
		160 N (440 N peak)	-	SGDV-04A05A-OY	SGDV-04A15A-OY	-	-
		280 N (600 N peak)	-	SGDV-08A05A-OY	SGDV-08A15A-OY	-	-
	560 N (1200 N peak)	-	SGDV-15A05A-OY-008000	SGDV-15A15A-OY-008000	-	-	
	400 V	80 N (220 N peak)	-	-	-	SGDV-05D05A-OY	SGDV-05D15A-OY
		160 N (440 N peak)	-	-	-	SGDV-05D05A-OY	SGDV-05D15A-OY
		280 N (600 N peak)	-	-	-	SGDV-10D05A-OY	SGDV-10D15A-OY
		560 N (1200 N peak)	-	-	-	SGDV-15D05A-OY	SGDV-15D15A-OY
1120 N (2400 N peak)		-	-	-	SGDV-30D05A-OY	SGDV-30D15A-OY	
1500 N (3600 N peak)	-	-	-	SGDV-20D05A-OY	SGDV-20D15A-OY		
2250 N (5400 N peak)	-	-	-	SGDV-30D05A-OY	SGDV-30D15A-OY		
 SGLTW Linear motors	400 V	300 N (600 N peak)	-	-	-	SGDV-10D05A-OY	SGDV-10D15A-OY
		600 N (1200 N peak)	-	-	-	SGDV-20D05A-OY	SGDV-20D15A-OY
		450 N (900 N peak)	-	-	-	SGDV-10D05A-OY	SGDV-10D15A-OY
		900 N (1800 N peak)	-	-	-	SGDV-20D05A-OY	SGDV-20D15A-OY
		670 N (2600 N peak)	-	-	-	SGDV-30D05A-OY	SGDV-30D15A-OY
		1000 N (4000 N peak)	-	-	-	SGDV-50D05A-OY	SGDV-50D15A-OY
		1300 N (5000 N peak)	-	-	-	SGDV-50D05A-OY	SGDV-50D15A-OY

Type designation

Servo drive

SGDV - 04 A 01 A - OY - □

Sigma-5 servo drive

Capacity

Voltage	Code	Output
230 V	A5	50 W
	01	100 W
	02	200 W
	04	400 W
	08	750 W
	15	1.5 kW
400 V	05	500 W
	10	1.0 kW
	15	1.5 kW
	20	2.0 kW
	30	3.0 kW
	50	5.0 kW
	210	6.0 kW
	260	7.5 kW
	280	11 kW
	370	15 kW

Source voltage

- A: 230 V
- D: 400 V

Code	Specifications
Blank	Standard
008000	Servo drive 1.5 kW single-phase 230 V

Omron-Yaskawa Motion Control B.V.
(Note: all models except 6 to 15 kW)

Design Revision Order: A, B...

Interface

Code	Specifications
01	Analog voltage/pulse train reference type (for rotary servomotors)
05	Analog voltage/pulse train reference type (for linear servomotors)
11	MECHATROLINK-II comms reference type (for rotary servomotors)
15	MECHATROLINK-II comms reference type (for linear servomotors)

Servo drive specifications

Single-phase, 230 V

Servo drive type	SGDV-□	A5A□□A-OY	01A□□A-OY	02A□□A-OY	04A□□A-OY	08A□□A-OY	15A□□A-OY-008000
Applicable servo motor	SGMAH-□	A3A□/A5A□	01A□	02A□	04A□	08A□	-
	SGMPH-□	-	01A□	02A□	04A□	08A□	15A□
	SGMJV-□	A5A□	01A□	02A□	04A□	08A□	-
	SGMAV-□	A5A□	01A□	C2A□/02A□	04A□	06A□/08A□	10A□
	SGMEV-□	-	01A□	02A□	04A□	08A□	15A□
Max. applicable motor capacity	W	50	100	200	400	750	1500
Continuous output current	Arms	0.66	0.91	1.6	2.8	5.5	11.6
Max. output current	Arms	2.1	2.9	6.5	9.3	16.9	28
Basic specifications	Input power	Main circuit Single-phase, 200 to 230 VAC + 10 to -15% (50/60 Hz)					
	Supply	Control circuit Single-phase, 200 to 230 VAC + 10 to -15% (50/60 Hz)					
	Control method	Single phase full-wave rectification / IGBT / PWM / sine-wave current drive method					
	Feedback	Serial encoder (incremental/absolute)					
	Conditions	Usage/storage temperature 0 to +55 °C / -20 to 85 °C					
		Usage/storage humidity 90%RH or less (non-condensing)					
		Altitude 1000m or less above sea level					
		Vibration/shock resistance 4.9 m/s ² / 19.6 m/s ²					
	Configuration	Base mounted					
	Approx. weight	Kg		0.9		1.0	1.5

Three-phase, 400 V

Servo drive type	SGDV-□	05D□	10D□	15D□	20D□	30D□	50D□	210D□	260D□	280D□	370D□
Applicable servo motor	SGMAH-□	03D□	07D□	-	-	-	-	-	-	-	-
	SGMPH-□	02D□/04D□	08D□	15D□	-	-	-	-	-	-	-
	SGMGH-□	05D□	09D□	13D□	20D□	30D□	44D□	55D□	75D□	1AD□	1ED□
	SGMSH-□	-	10D□	15D□	20D□	30D□	40D□/50D□	-	-	-	-
	SGMUH-□	-	10D□	15D□	-	30D□	40D□	-	-	-	-
	SGMEV-□	02/03/04D□	07D□/08D□	15D□	-	-	-	-	-	-	-
	SGMGV-□	03D□/05D□	09D□	13D□	20D□	30D□	44D□	55D□	75D□	1AD□	1ED□
	SGMSV-□	-	10D□	15D□	20D□	25D□	40D□/50D□	-	-	-	-
Max. applicable motor capacity	kW	0.5	1.0	1.5	2.0	3.0	5.0	6.0	7.5	11	15
Continuous output current	Arms	1.9	3.5	5.4	8.4	11.9	16.5	20.8	25.4	28.1	37.2
Max. output current	Arms	5.5	8.5	14	20	28	42	55	65	70	85
Basic specifications	Input power	Main circuit Three-phase, 380 to 480 VAC + 10 to -15% (50/60Hz)									
	Supply	Control circuit 24 VDC +/-15%									
	Control method	Three phase full-wave rectification / IGBT / PWM / sine-wave current drive method									
	Feedback	Serial encoder (incremental/absolute)									
	Conditions	Usage/storage temperature 0 to +55 °C / -20 to +85 °C									
		Usage/storage humidity 90%RH or less (non-condensing)									
		Altitude 1000 m or less above sea level									
		Vibration/shock resistance 4.9 m/s ² / 19.6 m/s ²									
	Configuration	Base mounted									
	Approx. weight	Kg		2.7		3.7		5.6		11.3	

Sigma-5 Analog/Pulse Reference Servo Drive

General specifications

Speed/torque control mode	Speed control range		1:5000	
	Speed variance	Load variance	During 0 to 100% load $\pm 0.01\%$ max. (at rated speed)	
		Voltage variance	Rated voltage $\pm 10\%:0\%$ (at rated speed)	
		Temperature variance	$25 \pm 25^\circ\text{C}$: $\pm 0.1\%$ max. (at rated speed)	
	Frequency characteristics		1.6 kHz	
	Torque control accuracy (Repeatability)		$\pm 1\%$	
	Soft start time setting		0 to 10 s (acceleration, deceleration can each be set.)	
	Input signal	Speed reference input	Reference voltage	± 6 VDC (forward motor rotation if positive reference) at rated speed: Set at delivery Variable setting range: ± 2 to ± 10 VDC at rated speed/ max. input voltage: ± 12 V
			Input impedance	Approx. 14 k Ω
			Circuit time constant	Approx. 30 μs
Torque reference input		Reference voltage	± 3 VDC (forward rotation if positive reference) at rated torque: Set at delivery Variable setting range ± 1 to ± 10 VDC at rated torque reference, max. input voltage: ± 12 V	
		Input impedance	Approx. 14 k Ω	
		Circuit time constant	Approx. 30 μs	
Position control mode	Feedforward compensation		0 to 100% (setting resolution: 1%)	
	Position completed width setting		0 to 1073741824 command units (setting resolution: 1 command unit)	
	Input signal	Command pulse	Input pulse type Input pulse form Input pulse frequency	Sign + pulse train, 90° phase displacement 2-phase pulse (A-phase+ B-phase) or CCW/CW pulse train Non-insulated line driver (+5 V level) , open collector. 0 to 4 Mpps (200 Kpps max. at open collector)
		Control signal		Clears error pulse by external signal
		Position signal output		A-phase, B.phase, C-phase: line driver output.
I/O signal	Sequence input signal		Servo ON, P control (or control mode switching, forward/reverse motor rotation by internal speed setting, zero clamp, command pulse inhibit), forward/reverse run prohibit, forward/reverse current limit (or internal speed switching), alarm reset.	
	Sequence output signal		Servo alarm, alarm codes (3-bit output): CN1 output terminal is fixed It is possible to output three types of signal form incl.: positioning complete, speed coincidence detection, servo-motor rotation detection, servo ready, current limit detection, speed limit detection, brake release, warning, NEAR.	
	USB Communications	Interface		Personal computer
Communications standard			Compliant with USB1.1 standard (12 Mbps)	
Function			Status display, parameter settings, adjustment functions, utility functions, alarm traceback display, JOG run/autotuning operations and graphing functions for speed/torque command signal, etc	
Integrated functions	Automatic load inertia detection		Automatic motor parameter setting. One parameter rigidity setting.	
	Dynamic brake (DB)		Operates during main power OFF, servo alarm, servo OFF or overtravel	
	Regenerative processing		Internal resistor included in models from 500 W to 5 kW. Regenerative resistor externally mounted (option).	
	Overtravel (OT) prevention function		DB stop, deceleration stop or coast to stop during P-OT, N-OT operation	
	Encoder divider function		Optional division pulses possible	
	Electronic gearing		$0,01 < \text{Numerator/Denominator} < 100$	
	Internal speed setting function		3 speeds may be set internally	
	Protective functions		Overcurrent, overvoltage, low voltage, overload, regenerative error	
	Analog monitor functions for supervision		Integrates analog monitor connector for supervision of the speed and torque reference signals, etc. Number of channels: 2 (Output voltage: ± 10 V DC)	
	Panel operator	Display functions		CHARGE, 7-segments LEDx5
		Panel operator keys		Used to set parameters (4 keys)
	Safety functions			Hard wire base block signal and status monitor (fixed output) of safety circuit
	Others			Reverse connection, zero search, automatic motor discrimination function, and DC reactor connection terminal for high frequency power suppression function.

I/O specifications

I/O signals (CN1) - input signals

Pin No.	Signal name	Function					
40	Common	/S-ON Servo ON: Turns ON the servo motor.					
41	/P-CON	Function selected by parameter.					
		Proportional control reference Switches the speed control loop from PI (proportional/integral) to P (proportional) control when ON.					
		Direction reference With the internal set speed selected: switch the rotation direction.					
		Control mode switching <table border="0" style="margin-left: 20px;"> <tr> <td style="padding-right: 10px;">Position ↔ speed</td> <td rowspan="3" style="font-size: 2em; vertical-align: middle;">}</td> <td rowspan="3">Enables control mode switching</td> </tr> <tr> <td>Position ↔ torque</td> </tr> <tr> <td>Torque ↔ speed</td> </tr> </table>	Position ↔ speed	}	Enables control mode switching	Position ↔ torque	Torque ↔ speed
		Position ↔ speed	}			Enables control mode switching	
		Position ↔ torque					
Torque ↔ speed							
Zero-clamp reference Speed control with zero-clamp function: reference speed is zero when ON.							
Reference pulse block Position control with reference pulse stop: stops reference pulse input when ON.							
42	P-OT	Forward run prohibited					
43	N-OT	Reverse run prohibited					
		Overtravel prohibited: Stops servo motor when movable part travels beyond the allowable range of motion.					
45	/P-CL	Function selected by parameter.					
		Forward external torque limit ON					
		Reverse external torque limit ON					
46	/N-CL	Current limit function enabled when ON.					
		Internal speed switching With the internal set speed selected: switches the internal speed settings.					
44	/ALM-RST	Alarm reset: releases the servo alarm state.					
47	+24VIN	Control power supply input for sequence signals: users must provide the +24 V power supply. Allowable voltage fluctuation range: 11 to 25 V					
4 (2)	SEN	Initial data request signal when using an absolute encoder.					
21	BAT (+)	Connecting pin for the absolute encoder backup battery.					
		BAT (-) Do not connect when the encoder cable for the battery case is used.					
5 (6)	Speed	V-REF Speed reference input: ± 2 to ± 10 V/rated motor speed (Input gain can be modified using a parameter).					
9 (10)	Torque	T-REF Torque reference input: ± 1 to ± 10 V/rated motor torque (Input gain can be modified using a parameter).					
7	Position	PULS /PULS SIGN /SIGN	Reference pulse input for line driver only				
			Input mode is set from the following pulses: Sign + pulse string CCW/CW pulse Two-phase pulse (90° phase differential)				
15	CLR	Positional error pulse clear input: clears the positional error pulse during position control.					
14	/CLR						

Note: 1. Pin numbers in parentheses () indicate signal grounds.

2. The functions allocated to /S-ON, /P-CON, P-OT, N-OT, /ALM-RST, /P-CL, and /N-CL input signals can be changed by using the parameters.

3. The voltage input range for speed and torque references is a maximum of ± 12 V.

I/O signals (CN1) - output signals

Pin No.	Signal Name	Function		
31 32	Common	ALM+ ALM-	Servo alarm: Turns OFF when an error is detected.	
27 28		/TGON+ /TGON-	Detection during servo motor rotation: detects when the servo motor is rotating at a speed higher than the motor speed setting.	
29 30		/S-RDY+ /S-RDY-	Servo ready: ON if there is no servo alarm when the control/main circuit power supply is turned ON.	
33 34		PAO /PAO	Phase-A signal	Two-phase pulse encoder output pulse signal
35 36		PBO /PBO		
19 20		PCO /PCO	Phase-C signal	Zero-point pulse signal
37 (1) 38 (1) 39 (1)		ALO1 ALO2 ALO3	Alarm code output: Outputs 3-bit alarm codes.	
Shell		FG	Connected to frame ground if the shield wire of the I/O signal cable is connected to the connector shell.	
25 26		Speed	/V-CMP+ /V-CMP-	Turns ON when whether the motor speed is within the setting range is detected and if it matches the reference speed value.
25 26		Position	/COIN+ /COIN-	Turns ON when the number of position error pulse reaches the value set.
-	Reserved	/CLT /VLT /BK /WARN /NEAR	Reserved terminals The functions allocated to /TGON, /S-RDY, and /V-CMP (/COIN) can be changed by using the parameters. /CLT, /VLT, /BK, /WARN and /NEAR signals can also be changed.	
3 13 16 17 18 23 24 48 49 50		-	Terminals not used. Do not connect.	

Note: 1. Pin numbers in parentheses () indicate signal grounds.

2. The functions allocated to /TGON, /S-RDY, and /V-CMP (/COIN) output signals can be changed by using the parameters. /CLT, /VLT, /BK, /WARN and /NEAR signals can also be changed.

I/O signals (CN8) - safety signals

Pin No.	Signal Name	Function	
4 3	Common	/HWBB1+ /HWBB1-	Hard wire baseblock input 1
6 5		/HWBB2+ /HWBB2-	Hard wire baseblock input 2
8 7		EDMI+ EDMI-	Monitored circuit status output 1: ON when the hard wire baseblock function is normally activated.
1 2	Reserved	-	Terminals not used. Do not connect.

Terminal specifications

Symbol	Name	Function
L1, L2 or L1, L2, L3	Main circuit AC input terminal	AC power input terminals for the main circuit
U, V, W	Servo motor connection terminal	Terminals for outputs to the servo motor.
L1C, L2C	Control power input terminal	AC power input terminals for the control circuit.
24V, 0V		24V DC power input terminals for the control circuit.
⊕	Frame ground	Ground terminal. Ground to a maximum of 100 Ω. (class 3).
B1/⊕, B2, B3	Main circuit DC output terminal	Up to 400 W: If the regenerative capacity is insufficient, connect an external regenerative resistor (option) between B1/⊕ and B2.
		From 500 W to 5 kW: Normally short B2 and B3. If the internal regenerative resistor is insufficient, remove the wire between B2 and B3 and connect an external regenerative resistor between B1/⊕ and B2.
⊖1, ⊖2	DC reactor connection terminal for suppressing power supply harmonic waves	Normally, short ⊖1 and ⊖2. If a countermeasure against power supply harmonic waves is needed, connect a DC reactor between ⊖1 and ⊖2.

Encoder connector (CN2)

Pin No.	Signal Name	Function
1	E5V	Encoder power supply + 5 V
2	E0V	Encoder power supply ground
3	BAT+	Battery + (used only with absolute encoder)
4	BAT-	Battery - (used only with absolute encoder)
5	S+	Encoder serial signal input
6	S-	Encoder serial signal input

Sigma-5 MECHATROLINK-II Servo Drives

General specifications

Position/speed/torque control mode	Speed control range		1:5000	
	Speed variance	Load variance	During 0 to 100% load $\pm 0.01\%$ max. (at rated speed)	
		Voltage variance	Rated voltage $\pm 10\%:0\%$ (at rated speed)	
		Temperature variance	25 ± 25 °C: $\pm 0.1\%$ max. (at rated speed)	
Performance	Frequency characteristics		1.6 kHz	
	Torque control accuracy (Repeatability)		$\pm 1\%$	
	Soft start time setting		0 to 10 s (acceleration, deceleration can each be set.)	
Command input	MECHATROLINK Communication		MECHATROLINK-II commands (for sequence, motion, data setting/reference, monitor, adjustment and other commands)	
	I/O signal			
I/O signal	Position signal output		A-phase, B-phase, C-phase: line driver output.	
	Sequence input signal		Homing deceleration limit switch, forward/reverse run prohibited, external latch signals, forward/reverse current limit.	
	Sequence output signal		It is possible to output three types of signal form incl.: positioning complete, speed coincidence detection, servo-motor rotation detection, servo ready, current limit detection, speed limit detection, brake release, warning, NEAR.	
Communications	USB Communications	Interface	Personal computer	
		Communications standard	Compliant with USB1.1 standard (12 Mbps)	
		Function	Status display, parameter setting, adjusting functions, utility functions, alarm traceback display, JOG run/autotuning operations and graphing functions for speed/torque command signal, etc	
	Mechatrolink Communications	Communications protocol		MECHATROLINK-II
		Station Address		41H to 5FH (max. number of slaves: 30)
		Transmission Speed		10 Mbps
		Transmission Cycle		250 μ s, 0.5 to 4.0 ms (multiple of 0.5 ms)
Data length		17-bytes and 32-bytes		
Integrated functions	Automatic load inertia detection		Automatic motor parameter setting. One parameter rigidity setting.	
	Dynamic brake (DB)		Operates during main power OFF, servo alarm, servo OFF or overtravel	
	Regenerative processing		Internal resistor included in models from 500 W to 5 kW. Regenerative resistor externally mounted (option).	
	Overtravel (OT) prevention function		DB stop, deceleration stop or coast to stop during P-OT, N-OT operation	
	Encoder divider function		Optional division pulses possible	
	Electronic gearing		0,01< Numerator/Denominator<100	
	Internal speed setting function		3 speeds may be set internally	
	Protective functions		Overcurrent, overvoltage, low voltage, overload, regeneration error	
	Analog monitor functions for supervision		Integrates analog monitor connectors for supervision of the speed and torque reference signals, etc. Number of channels: 2 (Output voltage: ± 10 V DC).	
	Panel operator	Display functions		CHARGE, 7-segments LEDX1
		Switches		Rotary switch: MECHATROLINK-II station address setting (16 channels) DIP switch: MECHATROLINK-II communications setting (4 channels)
	Safety functions		Hard wire base block signal and status monitor (fixed output) of safety circuit	
Others		Reverse connection, zero search, automatic motor discrimination function, and DC reactor connection terminal for high frequency power suppression function.		

I/O specifications

I/O signals (CN1) - input signals

Pin No.	Signal name		Function	
9	Common	/DEC	Homing deceleration limit switch	Connects the deceleration limit switch for homing.
7		P-OT	Forward run prohibited	Overtravel prohibited: Stops servo motor when movable part travels beyond the allowable range of motion.
8		N-OT	Reverse run prohibited	
10		/EXT 1	External latch signal 1	Connects the external signals that latch the current feedback pulse counter.
11		/EXT 2	External latch signal 2	
12		/EXT 3	External latch signal 3	
6		+24VIN	Control power supply input for sequence signals: users must provide the +24 V power supply. Allowable voltage fluctuation range: 11 to 25 V.	
14		BAT (+)	Connecting pin for the absolute encoder backup battery.	
15		BAT (-)	Do not connect when a battery is connected to the host controller.	
13		/SIO	General-purpose input signal: Monitored in the I/O monitor field of MECHATROLINK-II.	

- Note:**
- The functions allocated to /DEC, P-OT, N-OT, /EXT1, -/EXT2 and /EXT3 input signals can be changed by using the parameters.
 - If the Forward/ Reverse run prohibited function is used, the software can be used to stop the Servo drive. If the application does not satisfy the requirements, add an external circuit for safety reasons as required.

I/O signals (CN1) - output signals

Pin No.	Signal Name	Function
3 4	Common	ALM+ ALM- Servo alarm: Turns OFF when an error is detected.
1 2	/BK+ (/SO1+) /BK- (/SO1-)	Brake interlock signal Controls the brake. The brake is released when the signal turns ON. Allocation can be changed to general-purpose output signals (/SO1+, /SO1-).
23 24 25 26	/SO2+ /SO2- /SO3+ /SO3-	General-purpose output signal. Note: Set the parameter to allocate a function.
16	FG	Signal ground: Connected to frame ground if the shield wire of the I/O signal cable is connected to the connector shell.
17 18	PAO /PAO	Phase-A signal Dividing ratio can be set by parameter (proper line receiver is SN75175 manufactured by Texas instruments or the equivalent corresponding to MC3486)
19 20	PBO /PBO	Phase-B signal
21 22	PCO /PCO	Phase-C signal
5	Reserved	- Terminal not used. Do not connect.

I/O signals (CN8) - safety signals

Pin No.	Signal Name	Function
4 3	Common	/HWBB1+ /HWBB1- Hard wire baseblock input 1
6 5		/HWBB2+ /HWBB2- Hard wire baseblock input 2
8 7	EDMI+ EDMI-	Monitored circuit status output 1: ON when the hard wire baseblock function is normally activated.
1 2	Reserved	- Terminals not used. Do not connect.

Terminal specifications

Symbol	Name	Function
L1, L2 or L1, L2, L3	Main circuit AC input terminal	AC power input terminals for the main circuit
U, V, W	Servo motor connection terminal	Terminals for outputs to the servo motor.
L1C, L2C	Control power input terminal	AC power input terminals for the control circuit.
24V, 0		24V DC power input terminals for the control circuit.
⊕	Frame ground	Ground terminal. Ground to a maximum of 100 Ω. (class 3).
B1/⊕, B2, B3 or B1, B2, B3	Main circuit DC output terminal	Up to 400 W: If the regenerative capacity is insufficient, connect an external regenerative resistor (option) between B1/⊕ and B2. From 500 W to 5 kW: Normally short B2 and B3. If the internal regenerative resistor is insufficient, remove the wire between B2 and B3 and connect an external regenerative resistor between B1/⊕ and B2.
⊖1, ⊖2	DC reactor connection terminal for suppressing power supply harmonic waves	Normally, short ⊖1 and ⊖2. If a countermeasure against power supply harmonic waves is needed, connect a DC reactor between ⊖1 and ⊖2.

Encoder connector (CN2)

Pin No.	Signal Name	Function
1	E5V	Encoder power supply + 5 V
2	E0V	Encoder power supply ground
3	BAT+	Battery + (used only with absolute encoder)
4	BAT-	Battery - (used only with absolute encoder)
5	S+	Encoder serial signal input
6	S-	Encoder serial signal input

Operation

Sigma-5 Analog/Pulse Reference Servo Drive

Panel operator

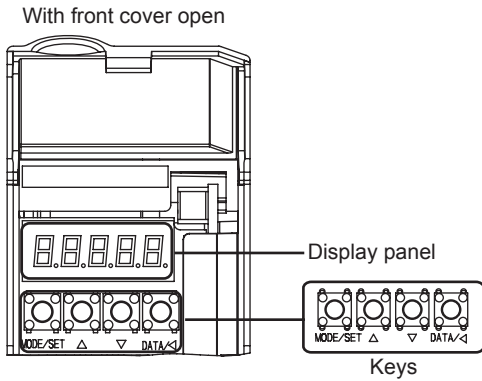

Changing modes

To change modes, press the MODE/SET key.

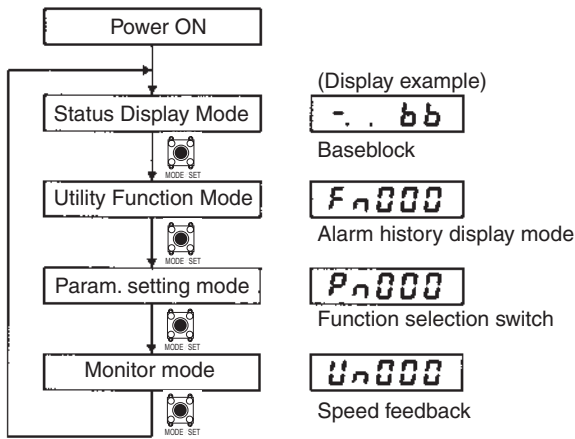

Status display mode

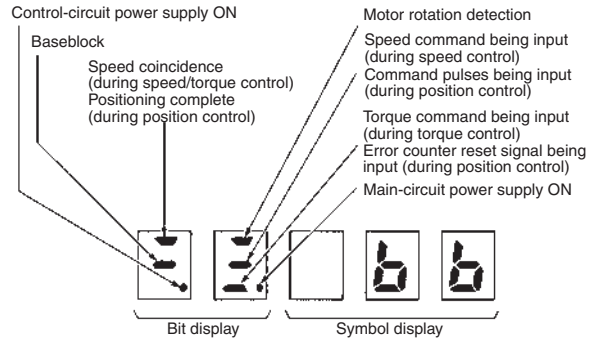

Symbol	Status
<i>bb</i>	Baseblock (servo OFF)
<i>run</i>	Operating (servo on)
<i>For</i>	Forward rotation prohibited (forward overtravel)
<i>Rev</i>	Reverse rotation prohibited (reverse overtravel)
<i>H.bb</i>	Hard Wire Base Block. Servo drive is baseblocked by the safety function
<i>tSt</i>	Mode test without motor
<i>020</i>	Alarm. Blinks the alarm number

Keys

Key name	SGDV-□□□□A-OY	Function
MODE/SET Key		Selects the display mode (status display mode, utility function mode, parameter setting mode and monitor mode). Used as a data setting key while in setting mode.
UP Key		Turns the servo ON or OFF while jog operations are being performed.
DOWN Key		Increases parameter settings. Used as a forward rotation start key during jog operation.
DATA/SHIFT Key		Decrements parameter settings. Used as a reverse rotation start key during jog operation.
UP Key + DOWN Key		To set and display the set value. Selects the digit whose setting is to be changed. When selected, the digit flashes.
		Pressing the UP Key and the Down Key simultaneously, resets an alarm.

Sigma-5 MECHATROLINK-II Servo Drives

Display panel

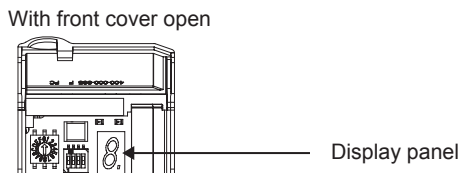

Status display mode

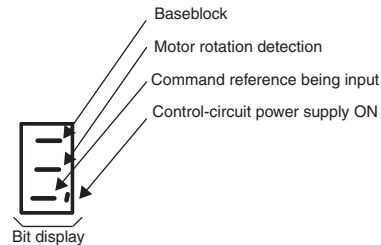

Symbol	Status
<i>R. E 6 0</i>	A.E60.Alarm number 60
<i>H. b b</i>	Hard Wire Base Block. Servo drive is baseblocked by the safety function
<i>t S t</i>	Mode test without motor

Dimensions

Sigma-5 Analog/Pulse Reference Servo Drive

SGDV-A5A0□A-OY to -02A0□A-OY (230 V, 50 to 200 W)

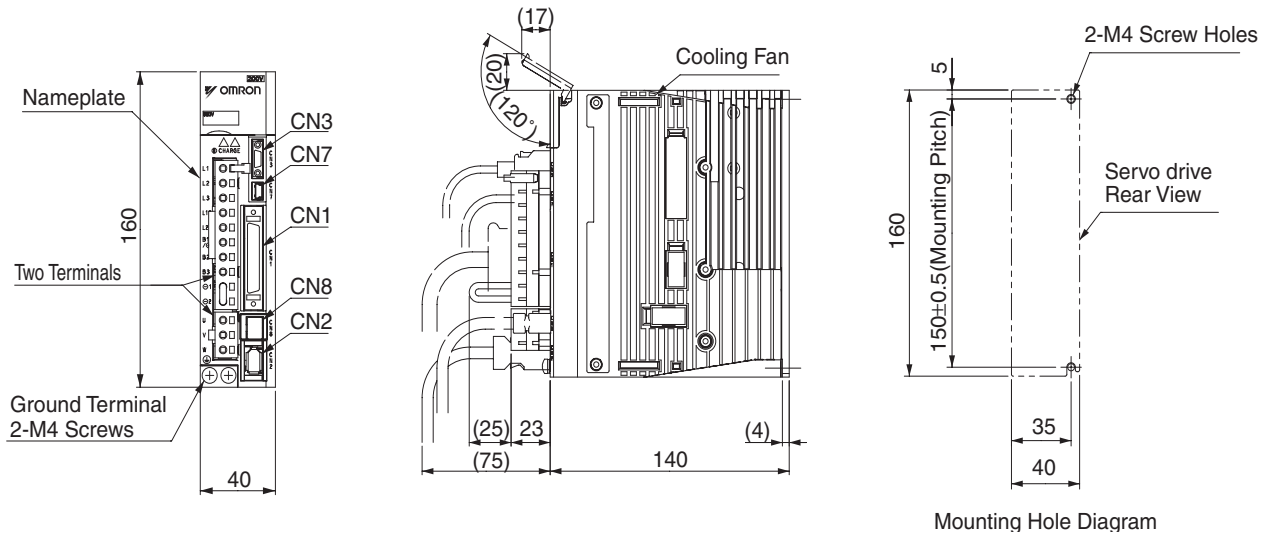

SGDV-04A0□A-OY (230 V, 400 W)

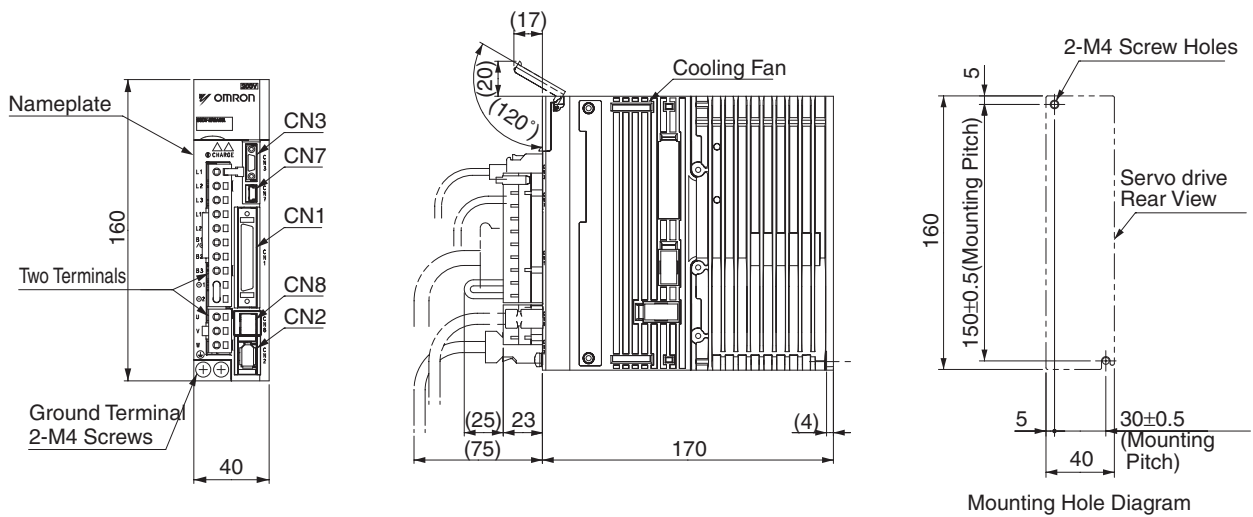

SGDV-08A0□A-OY (230 V, 750 W)

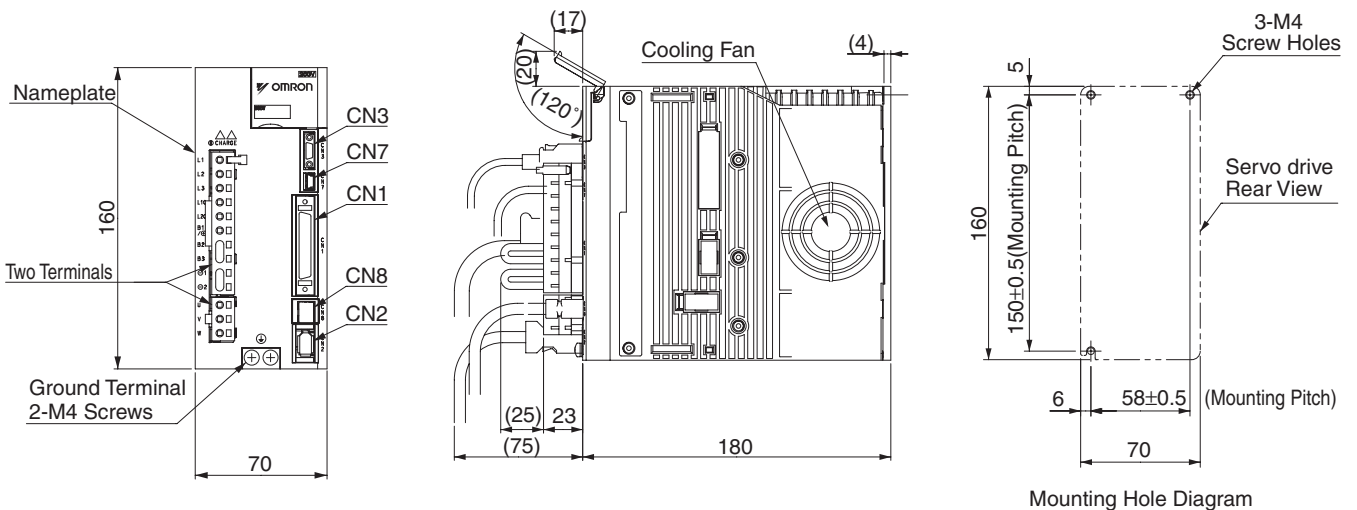

SGDV-15A0□A-OY (230 V, 1.5 kW)

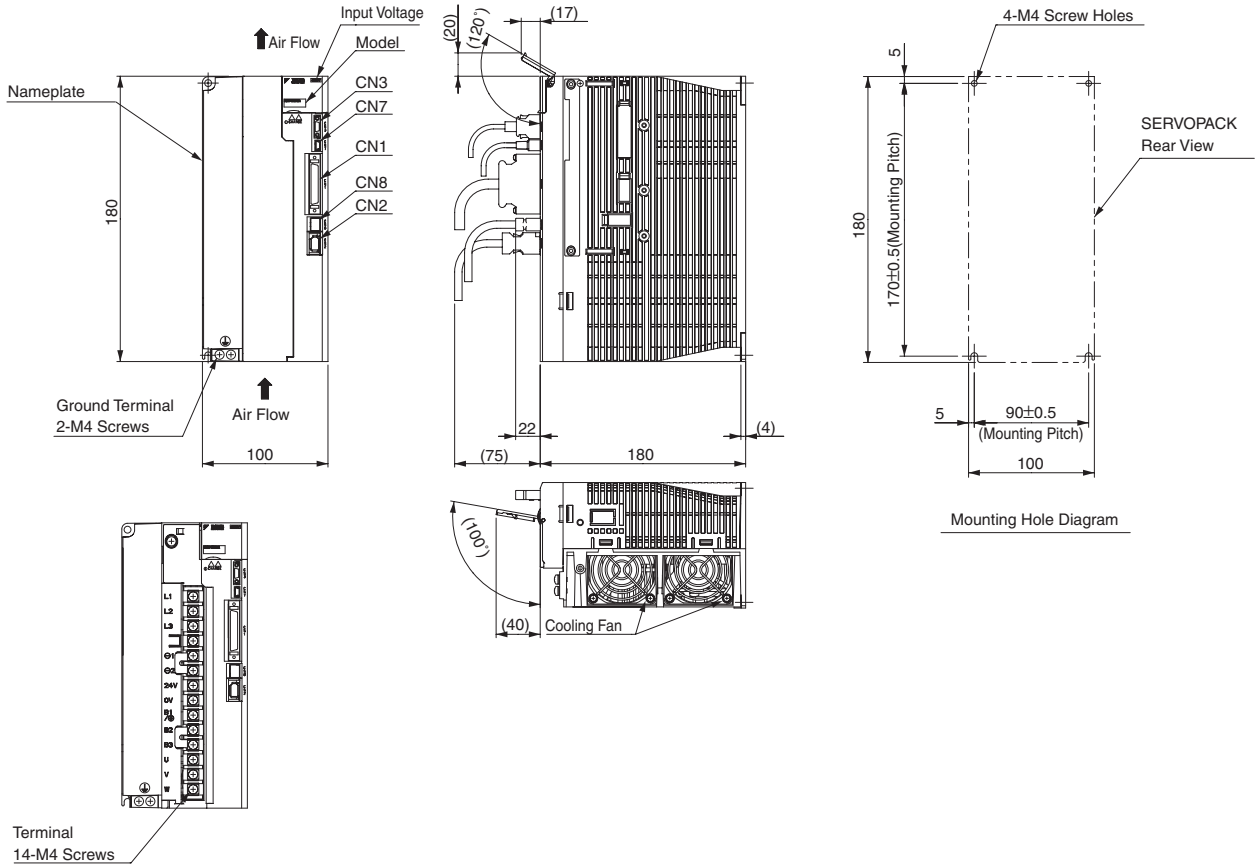

SGDV-05D0□A-OY to -15D0□A-OY (400 V, 0.5 to 1.5 kW)

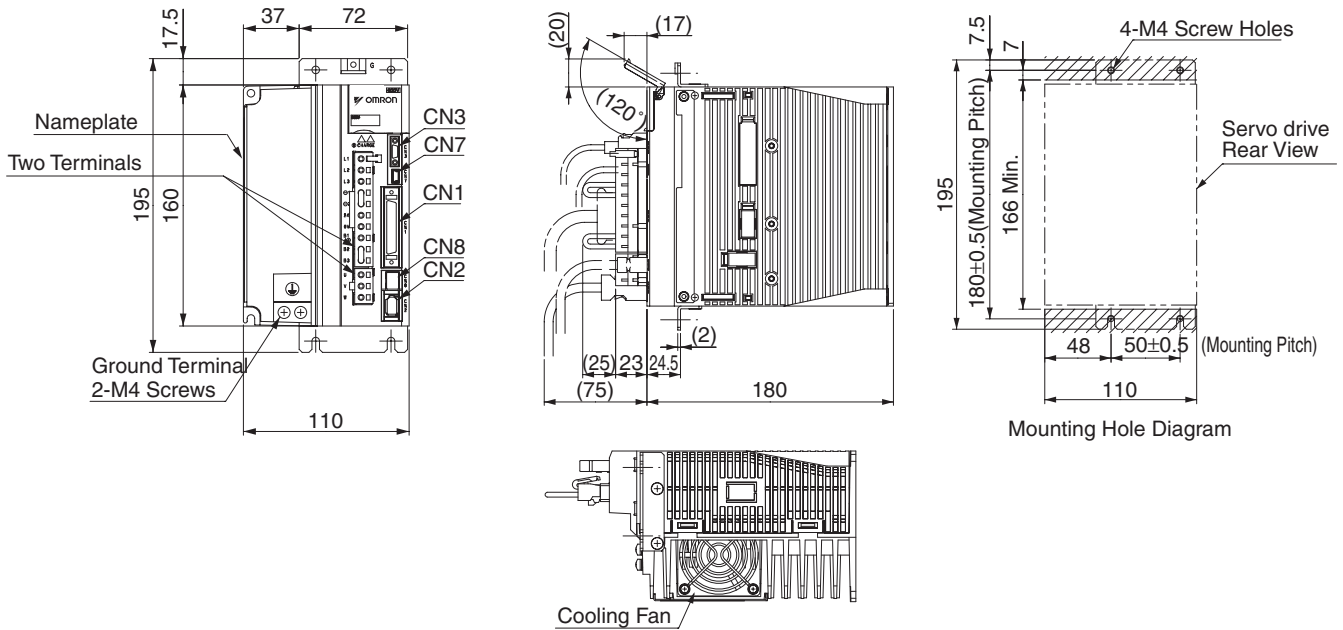

SGDV-20/30D0□A-OY (400 V, 2/3 kW)

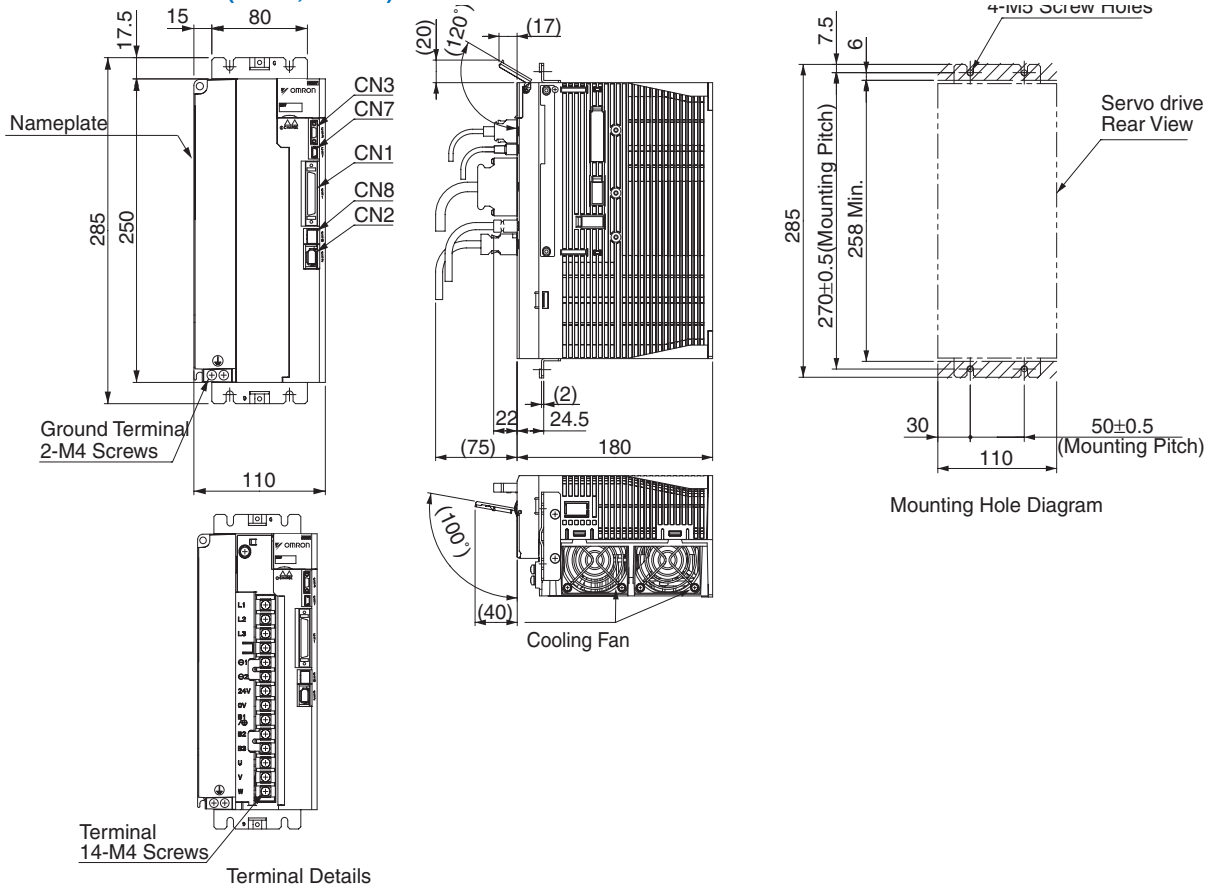

SGDV-50D0□A-OY (400 V, 5 kW)

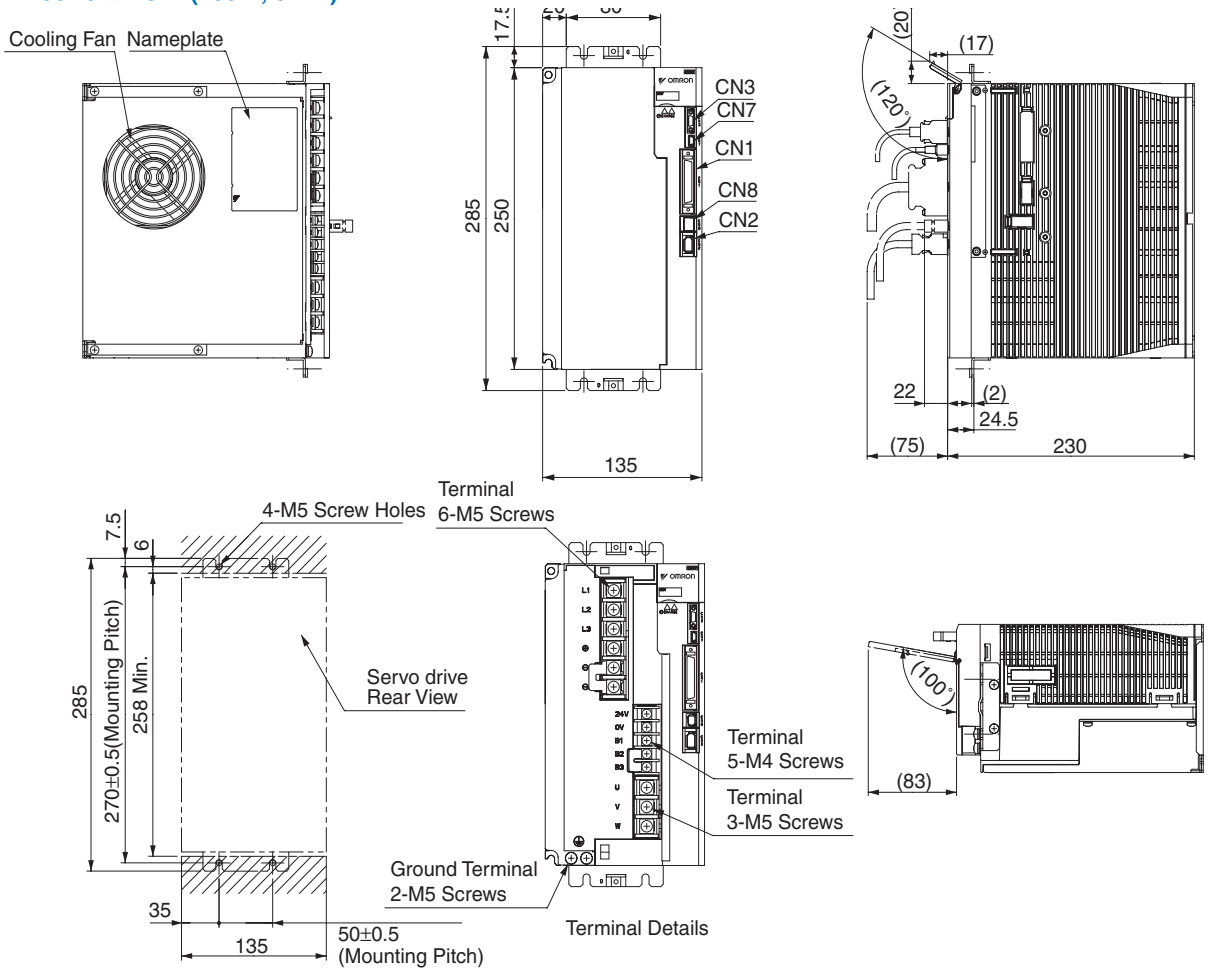

SGDV-210D0□A to 260D0□A (400 V, 6 to 7.5 kW)

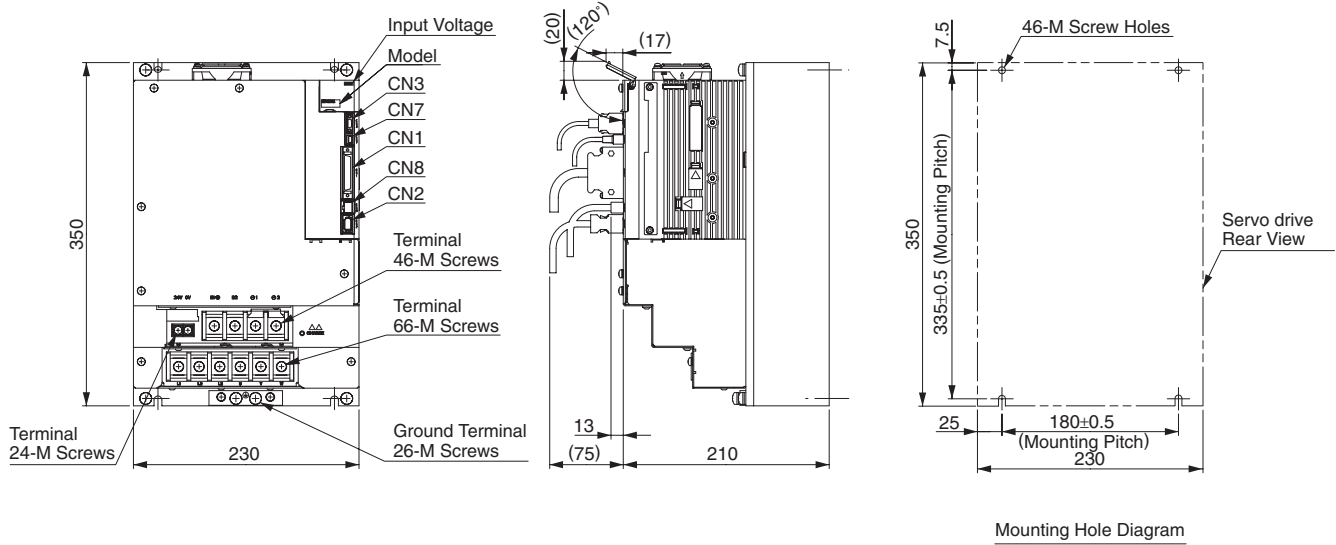

SGDV-280D0□A to 370D0□A (400 V, 11 to 15 kW)

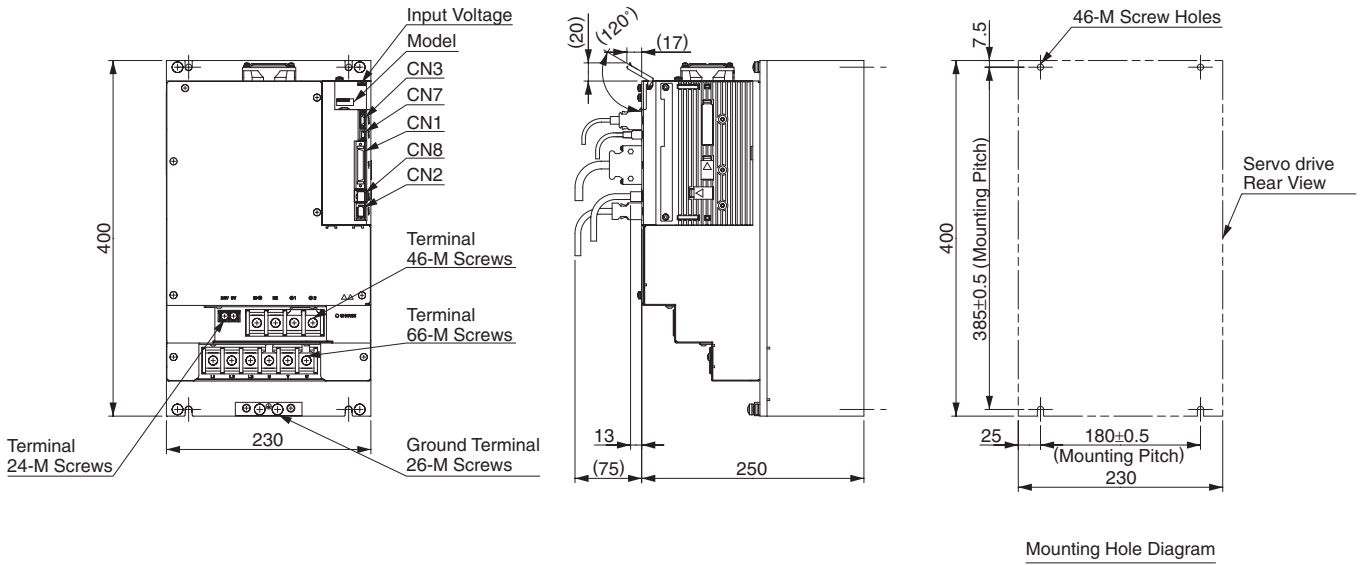

Sigma-5 MECHATROLINK-II Servo Drives

SGDV-A5A1□A-OY to -02A1□A-OY (230 V, 50 to 200 W)

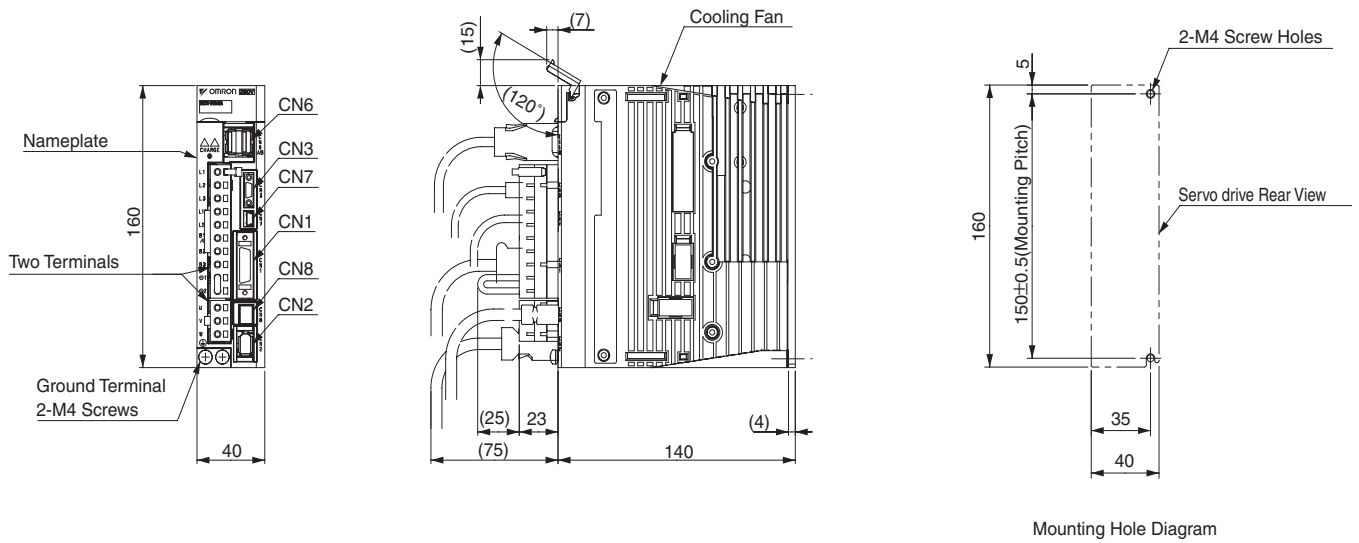

SGDV-04A1□A-OY (230 V, 400 W)

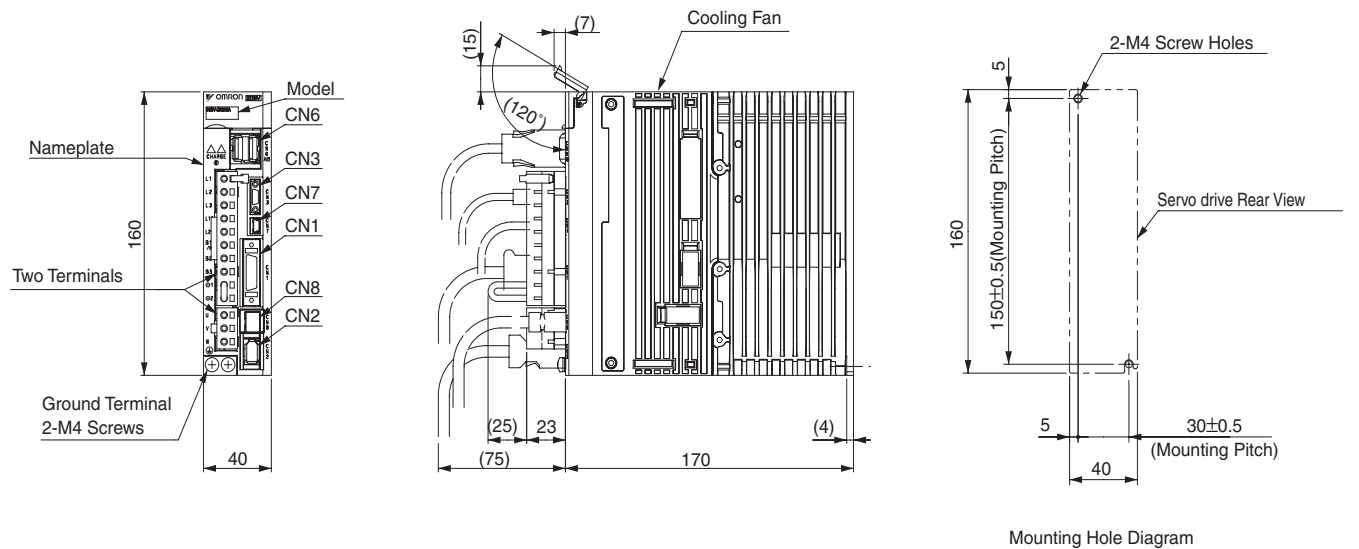

SGDV-08A1□A-OY (230 V, 750 W)

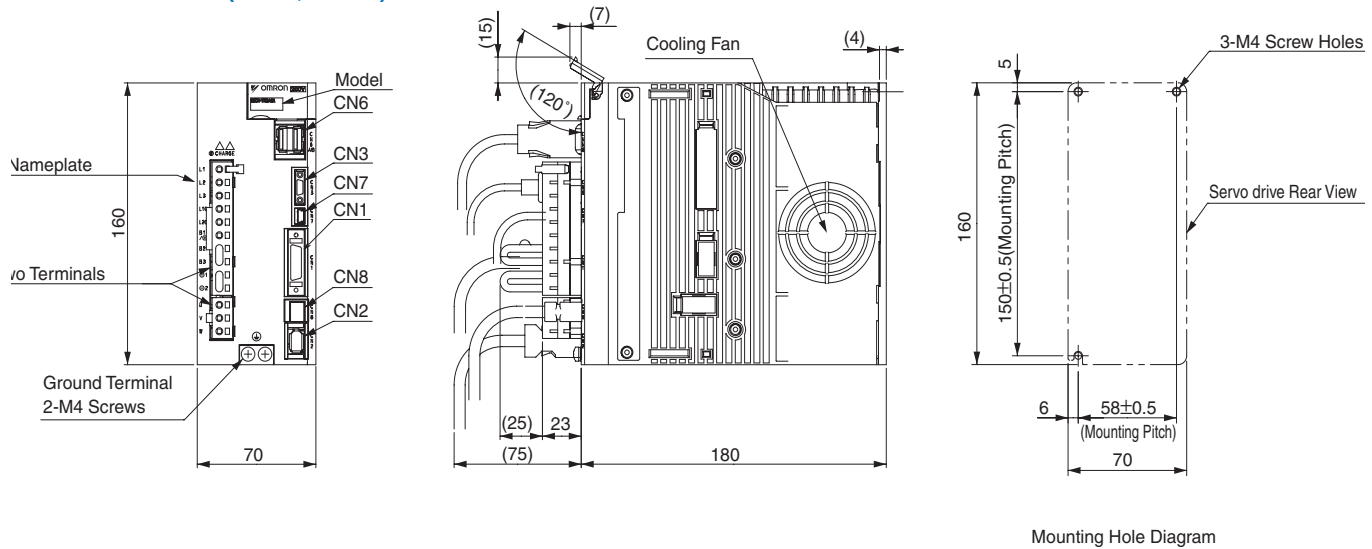

SGDV-15A1□A-OY (230 V, 1.5 kW)

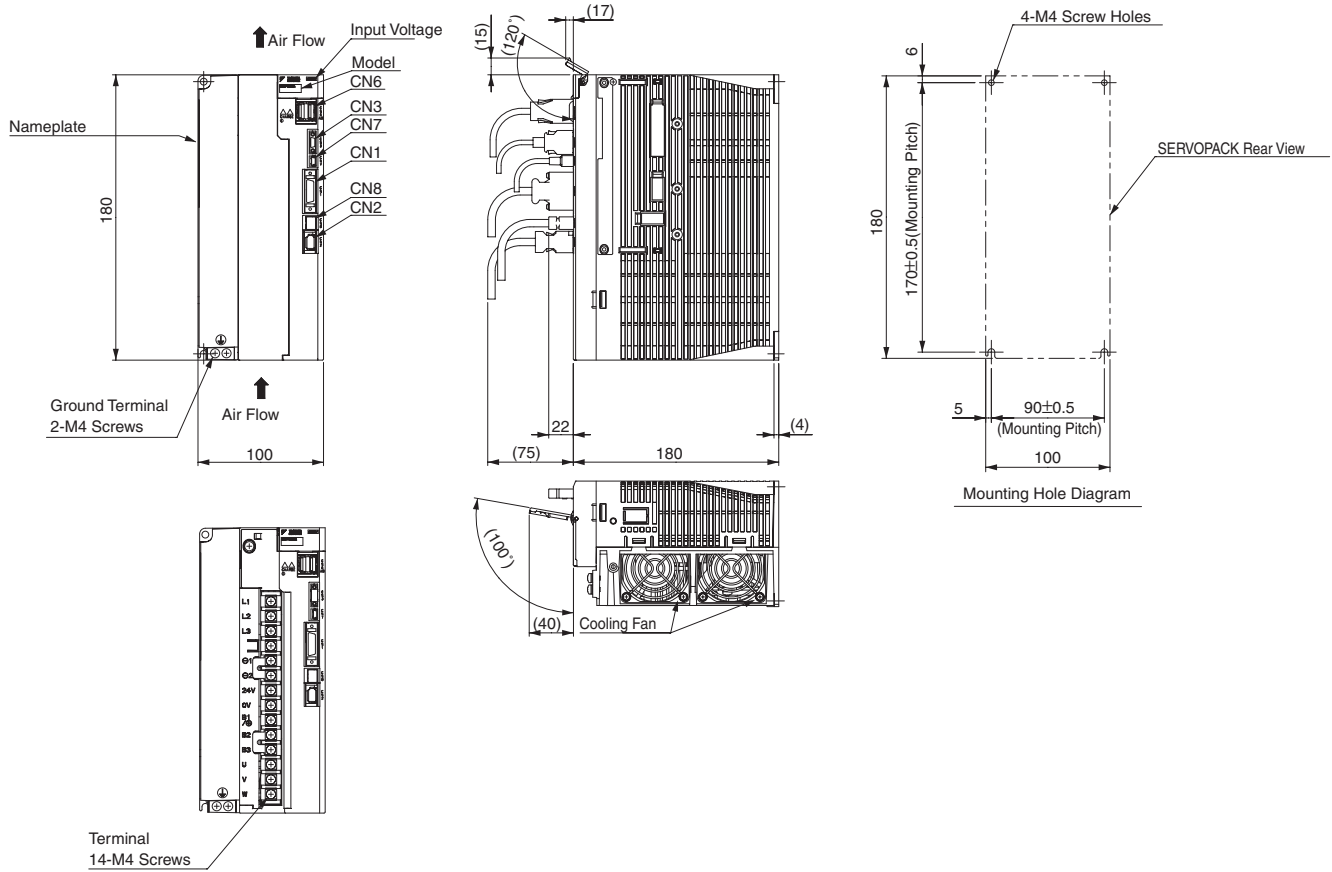

SGDV-05D1□A-OY to -15D1□A-OY (400 V, 0.5 to 1.5 kW)

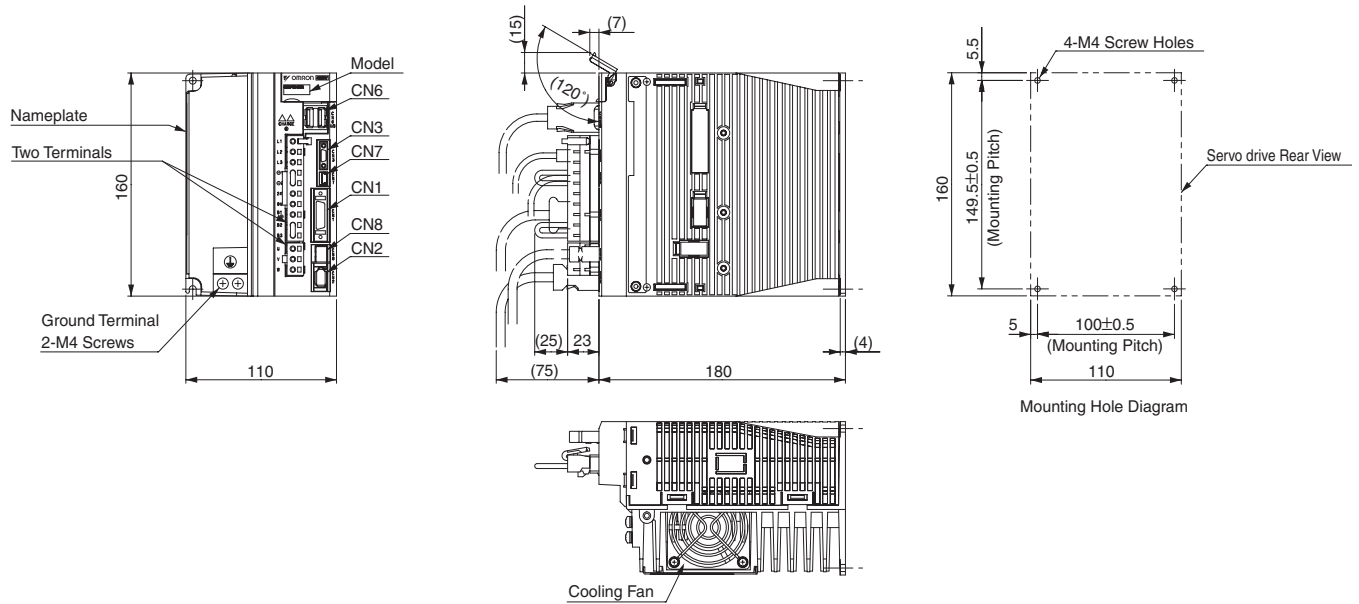

SGDV-20/30D1□A-OY (400 V, 2/3 kW)

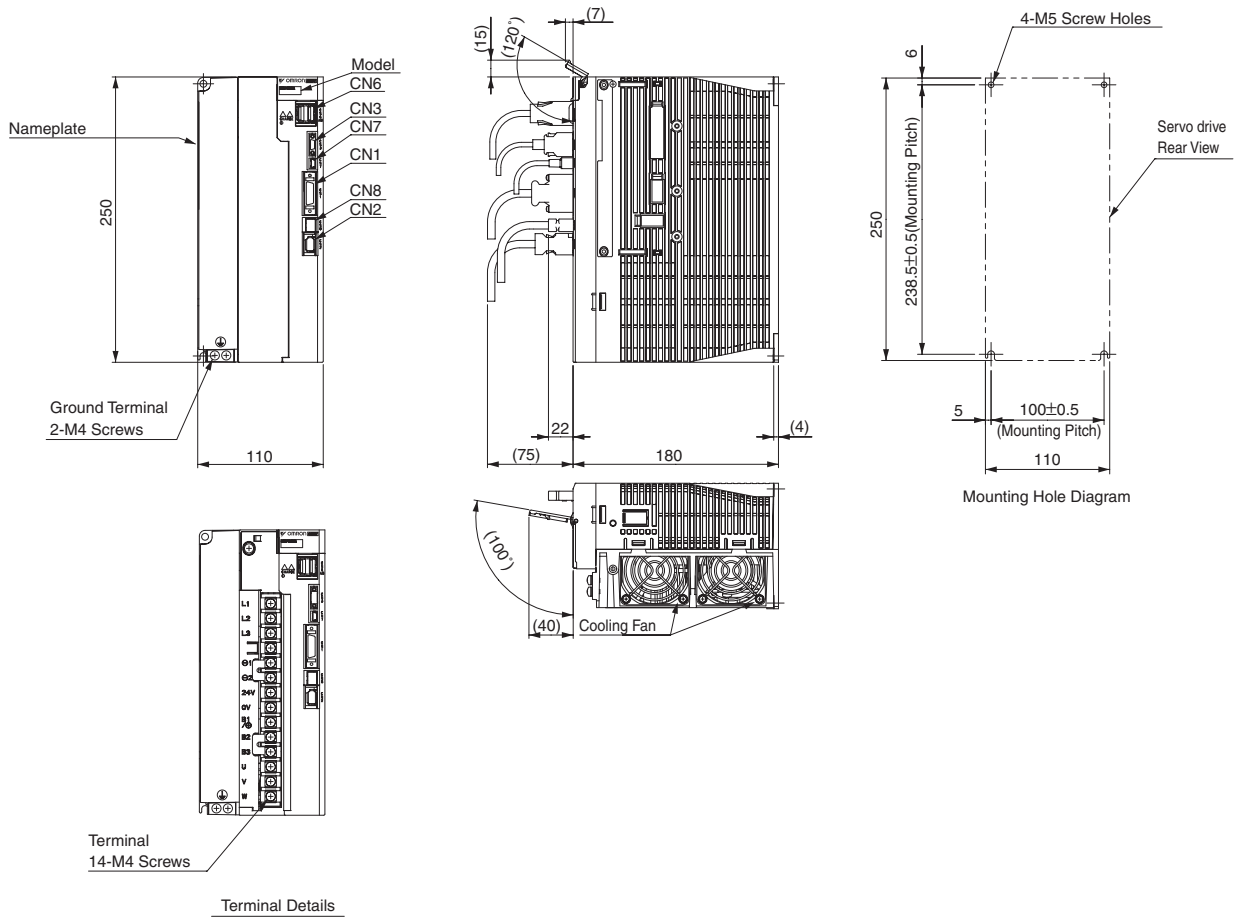

SGDV-50D1□A-OY (400 V, 5 kW)

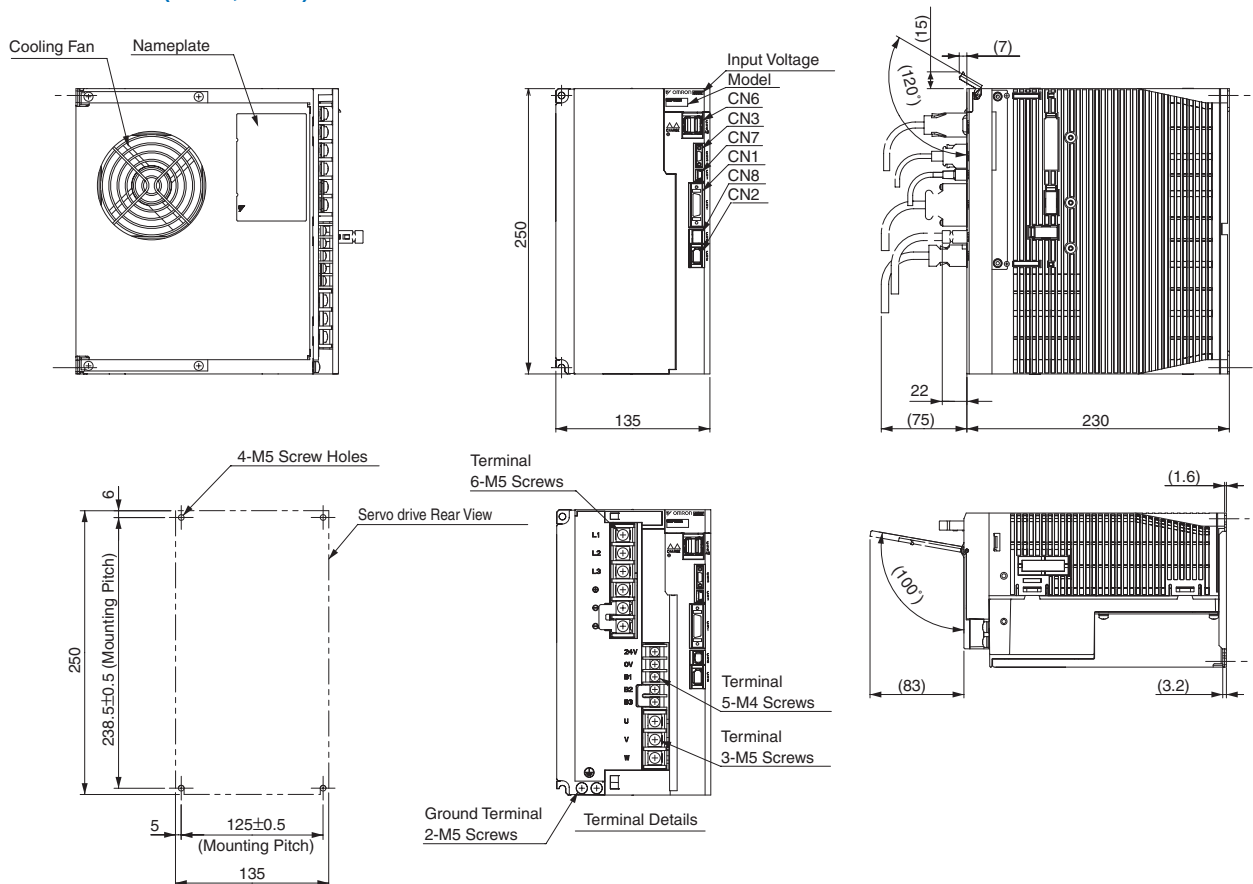

SGDV-210D1□A to 260D1□A (400 V, 6 to 7.5 kW)

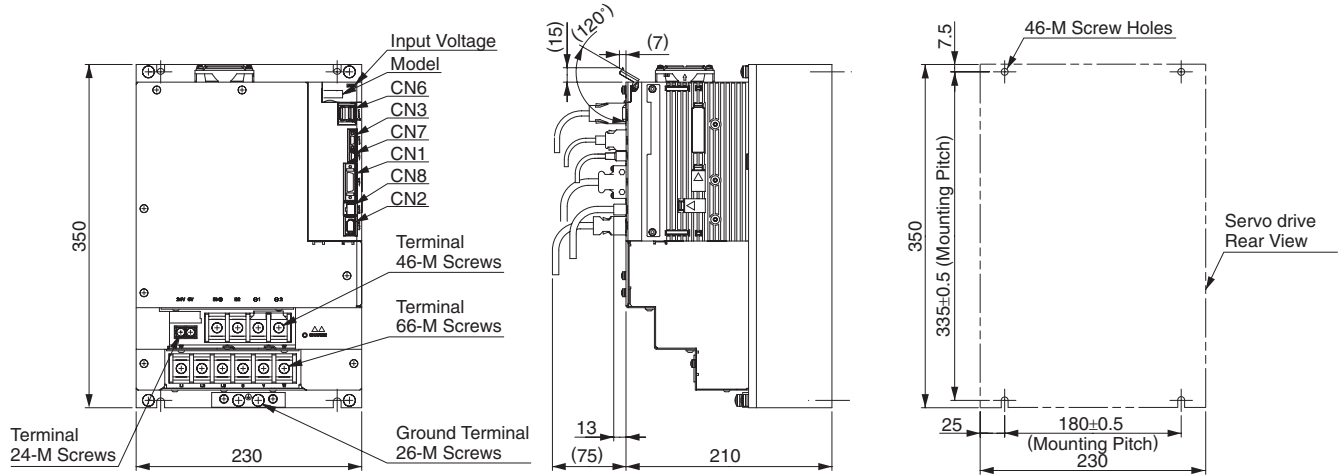

Mounting Hole Diagram

SGDV-280D1□A to 370D1□A (400 V, 11 to 15 kW)

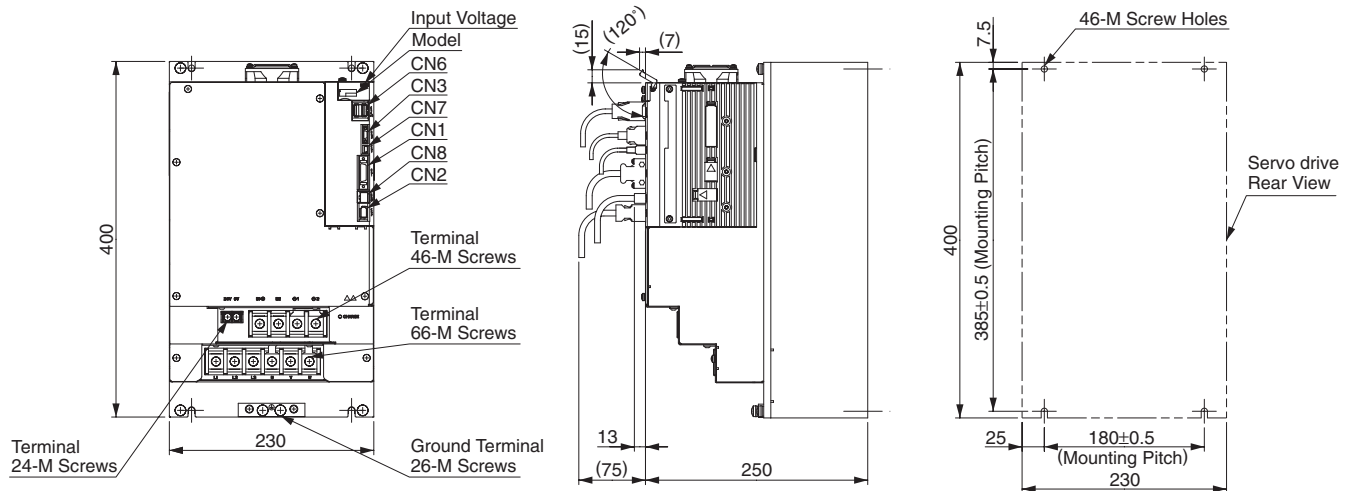

Mounting Hole Diagram

Filters

R88A-FI5-1005-RE

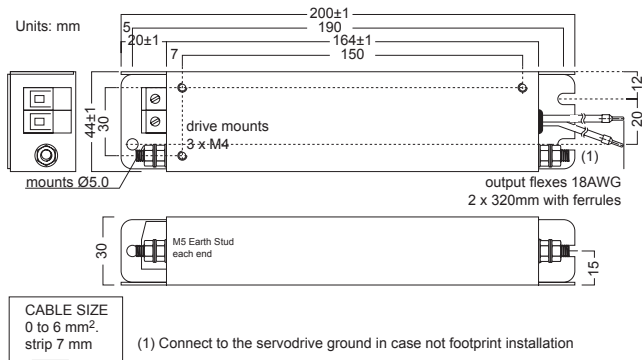

R88A-FI5-1009-RE

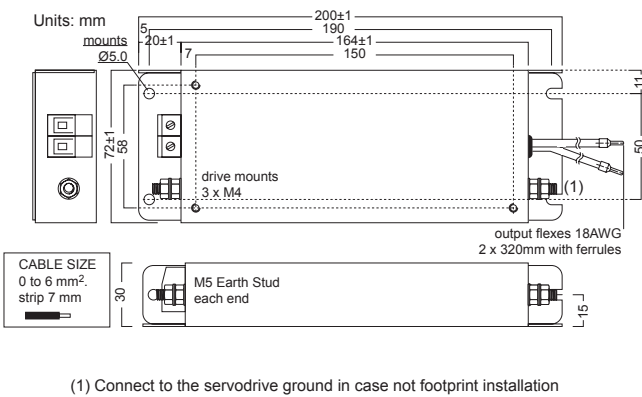

R88A-FI5-1016-RE

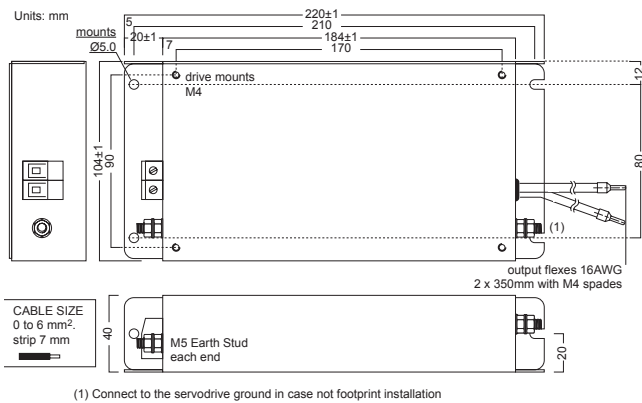

R88A-FI5-3004-RE

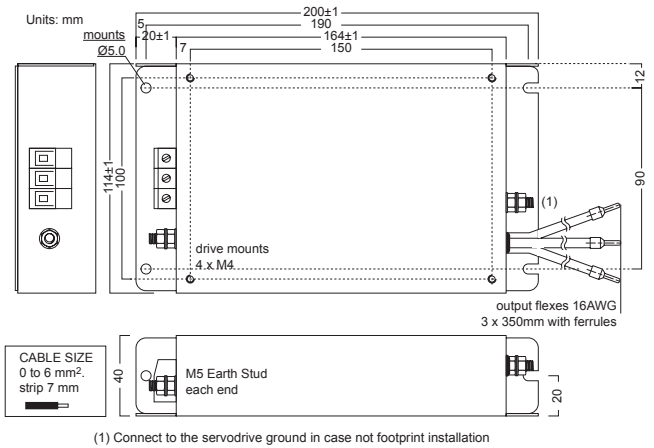

R88A-FI5-3008-RE

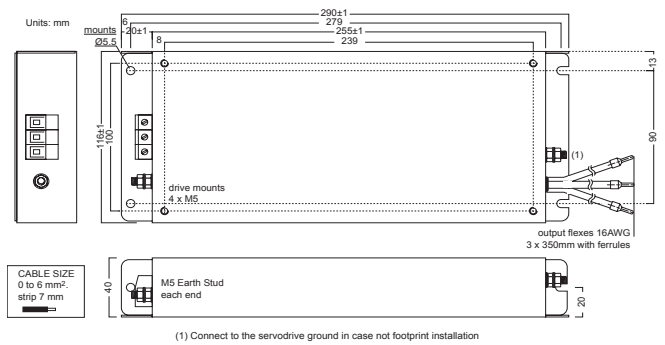

R88A-FI5-3012-RE

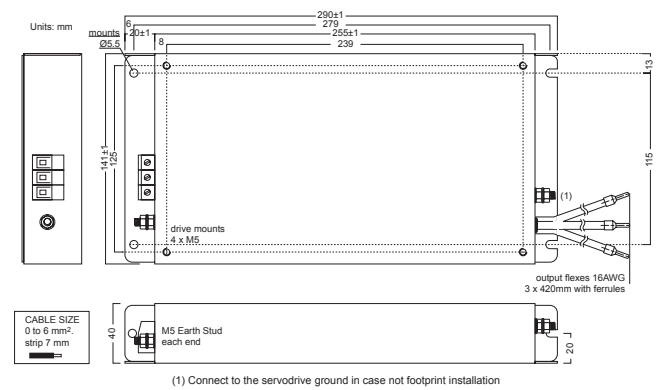

Single-phase, 230 VAC

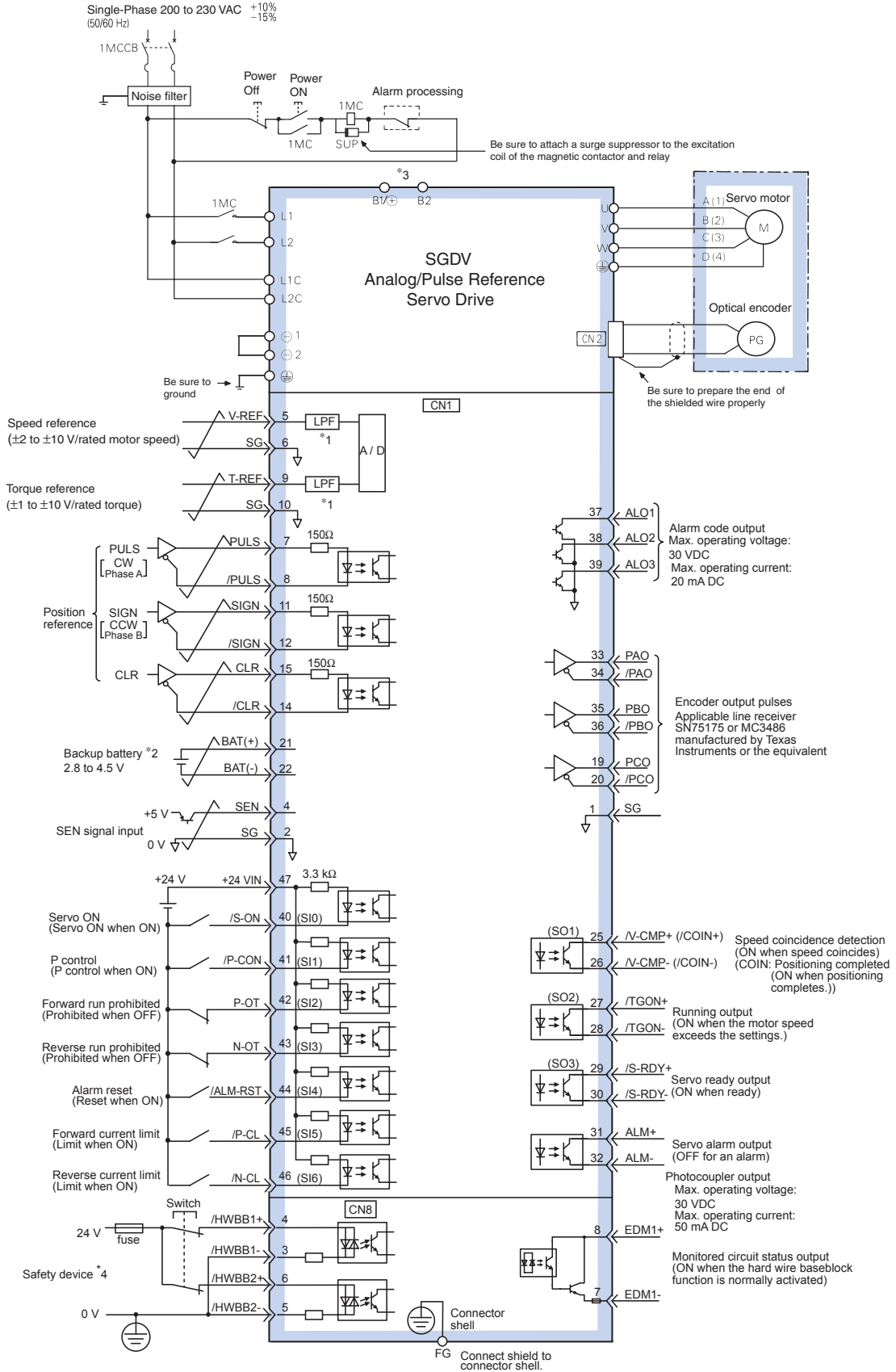

*1 The time constant for the primary filter is 30 μ s.

*2 Connect when using an absolute encoder. When the encoder cable for the battery case is connected, do not connect a backup battery.

*3 Regenerative resistor can be connected between B1 and B2. For 750 W servo drives types normally short B2 and B3.

*4 For servo ON, connect to safety device and set wiring to enable safety function. When not using the safety function, use the servo drive with the plug (JZSP-CVH05-E, provided as an accessory) inserted into the CN8.

Three-phase, 400 VAC

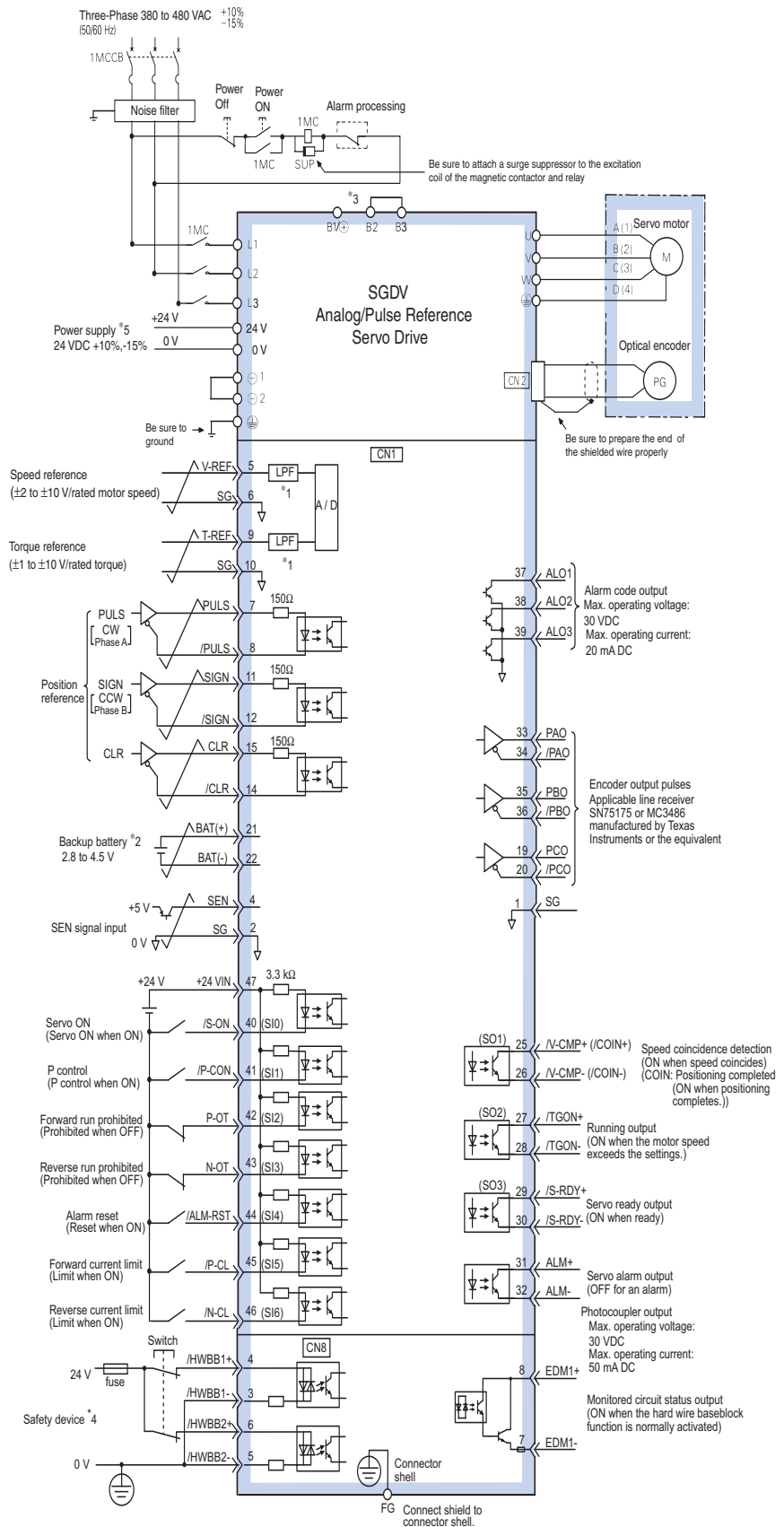

- *1 The time constant for the primary filter is 30 μ s.
- *2 Connect when using an absolute encoder. When the encoder cable for the battery case is connected, do not connect a backup battery.
- *3 Normally short B2 and B3. If the internal regenerative resistor is insufficient, remove the wire between B2 and B3 and connect an external regenerative resistor between B1 and B2.
- *4 For servo ON, connect to safety device and set wiring to enable safety function. When not using the safety function, use the servo drive with the plug (JZSP-CVH05-E, provided as an accessory) inserted into the CN8.
- *5 It is the user's responsibility to obtain 24 VDC power supply.

Single-phase, 230 VAC

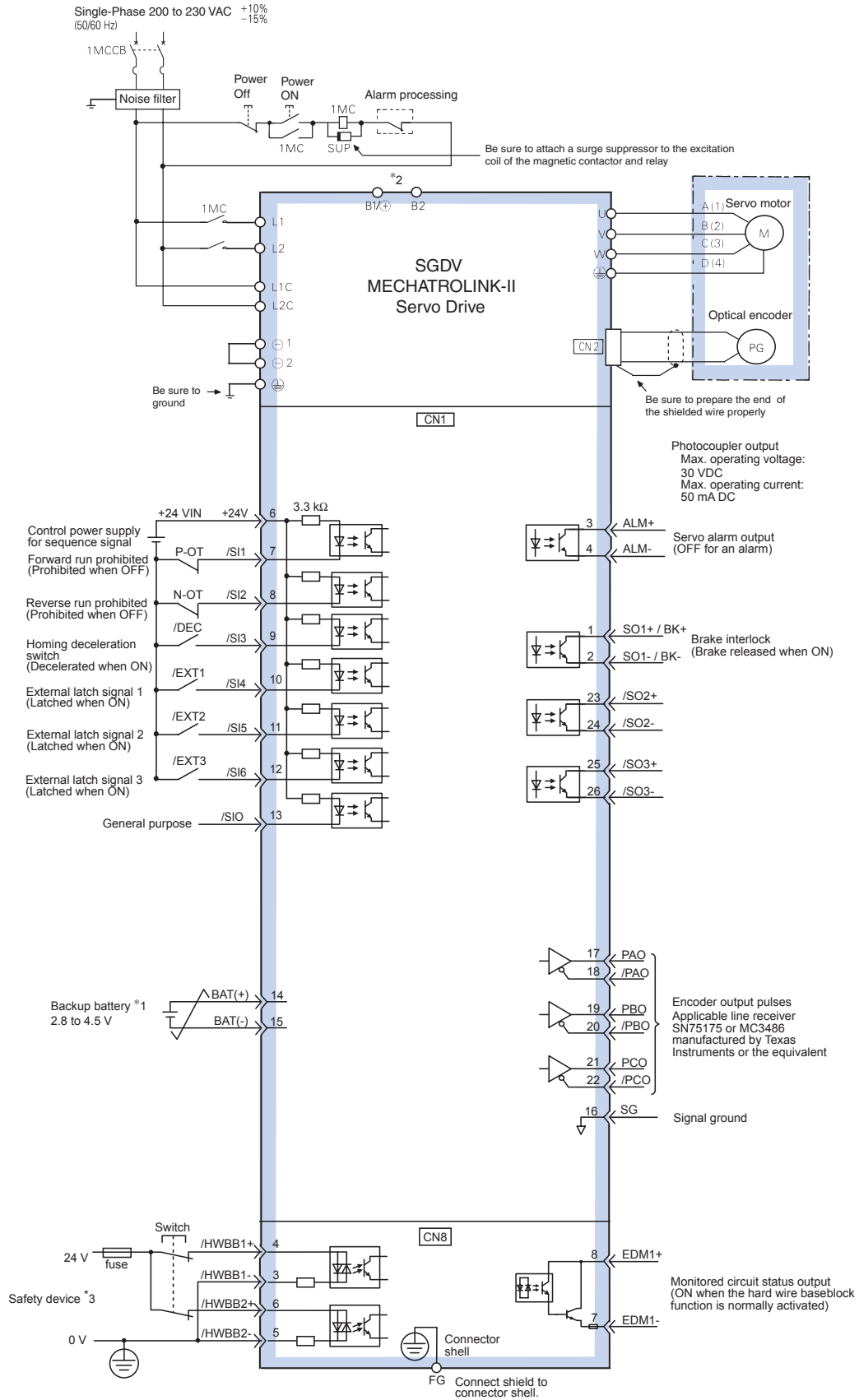

*1 Connect when using an absolute encoder. When the encoder cable for the battery case is connected, do not connect a backup battery.
 *2 Regenerative resistor can be connected between B1 and B2. For 750 W servo drives types normally short B2 and B3.
 *3 For servo ON, connect to safety device and set wiring to enable safety function. When not using the safety function, use the servo drive with the plug (JZSP-CVH05-E, provided as an accessory) inserted into the CN8.

Three-phase, 400 VAC

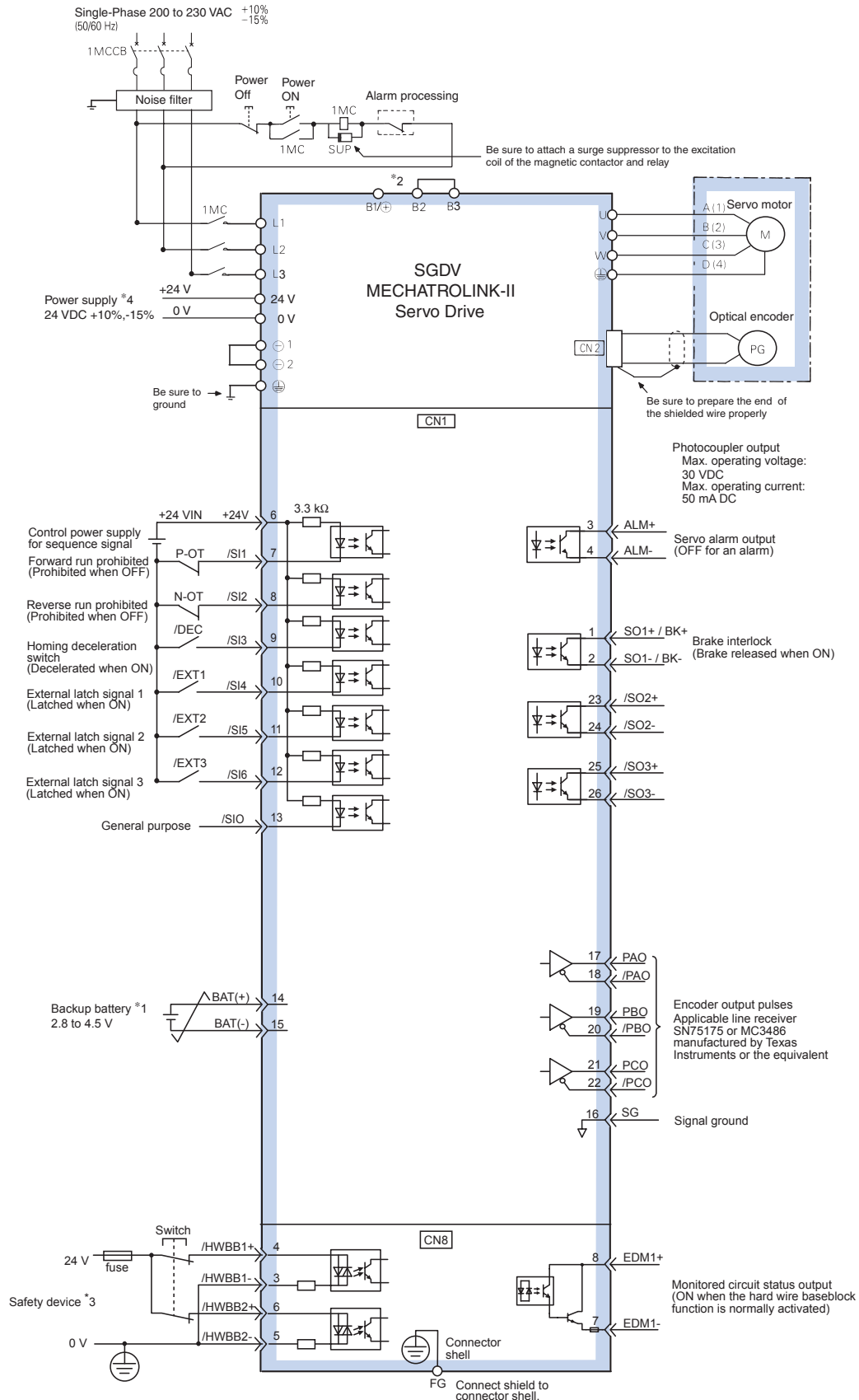

- *1 Connect when using an absolute encoder. When the encoder cable for the battery case is connected, do not connect a backup battery.
- *2 Normally short B2 and B3. If the internal regenerative resistor is insufficient, remove the wire between B2 and B3 and connect an external regenerative resistor between B1 and B2.
- *3 For servo ON, connect to safety device and set wiring to enable safety function. When not using the safety function, use the servo drive with the plug (JZSP-CVH05-E, provided as an accessory) inserted into the CN8.
- *4 It is the user's responsibility to obtain 24 VDC power supply.

Ordering information

Sigma-5 Analog/Pulse Reference Configuration

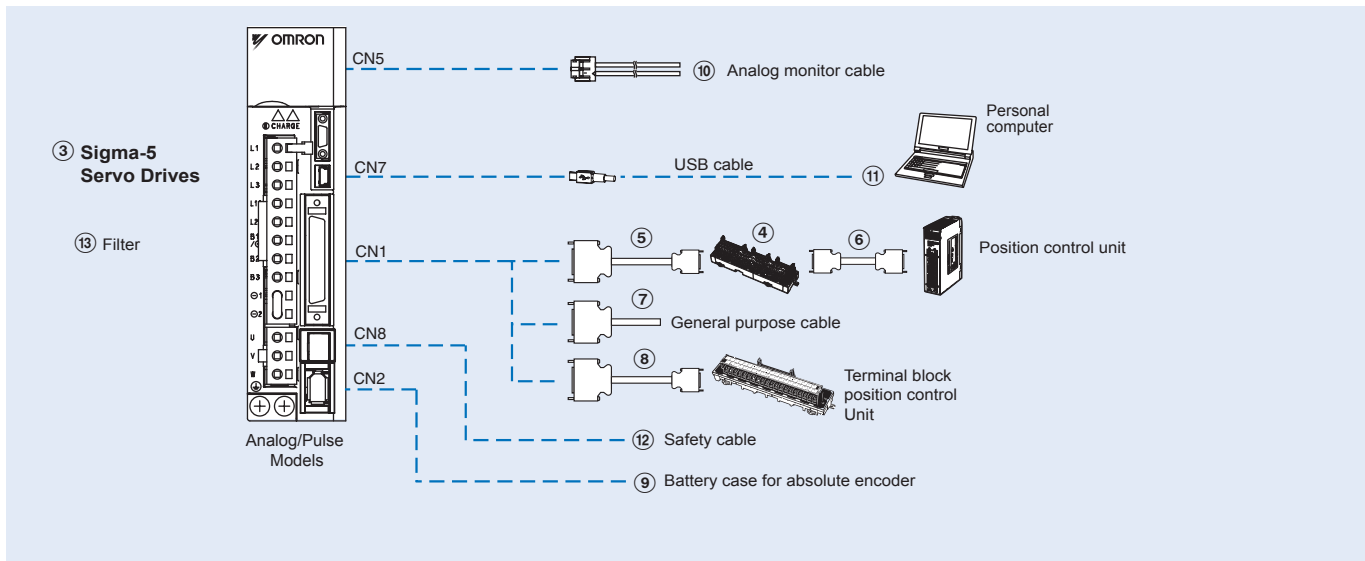

(Refer to chapter Sigma-II rotary motors)

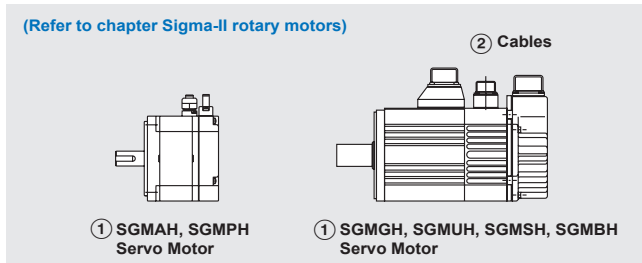

(Refer to chapter Sigma linear motors)

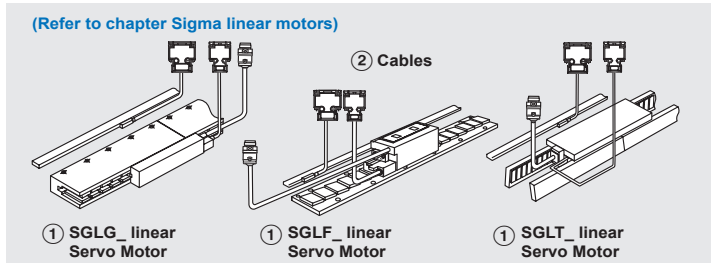

(Refer to chapter Sigma-5 rotary motors)

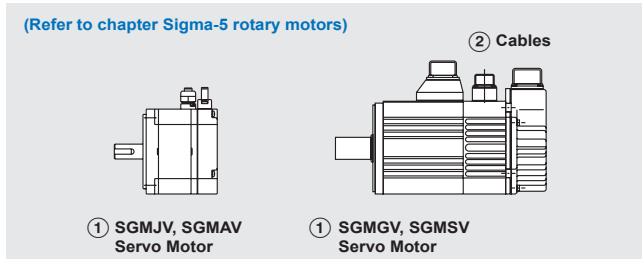

(Refer to chapter Sigma direct drive motors)

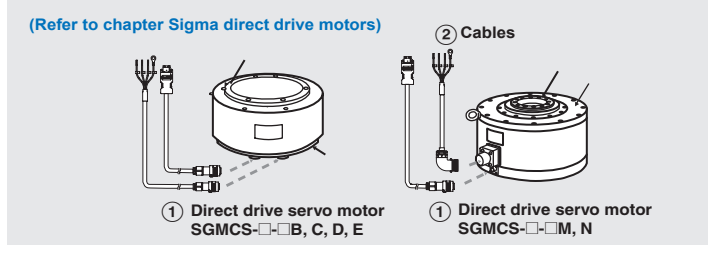

Note: The symbols ①②③④⑤... show the recommended sequence to select the components in a Sigma-5 servo system

Servo motors, power & encoder cables

Note: ①② Refer to the servo motors chapter for detailed motor specifications and selection

Servo drives

Symbol	Specifications	Model	Compatible rotary servo motors ①	Compatible direct drive motors ①	Compatible linear motors ①		
③	1 phase 230 VAC	50 W	SGDV-A5A01A-OY	SGMAH-A5D□, SGMJV-A5A□, SGMAV-A5A□	-	-	
			SGDV-A5A05A-OY	-	-	SGLGW-30A050□	
		100 W	SGDV-01A01A-OY	SGMAH-01A□, SGMPH-01A□, SGMJV-01A□, SGMAV-01A□, SGMEV-01A□	-	-	-
			SGDV-01A05A-OY	-	-	SGLGW-30A080□, SGLGW-40A140□	
		200 W	SGDV-02A01A-OY	SGMAH-02A□, SGMPH-02A□, SGMJV-02A□, SGMAV-02A□, SGMEV-02A□	SGMCS-07B□	-	-
			SGDV-02A05A-OY	-	-	SGLGW-60A140□, SGLGW-40A253□, SGLFW-20A□, SGLFW-35A120□	
		400 W	SGDV-04A01A-OY	SGMAH-04A□, SGMPH-04A□, SGMJV-04A□, SGMAV-04A□, SGMEV-04A□	SGMCS-02B□, SGMCS-05B□, SGMCS-04C□, SGMCS-10C□, SGMCS-14C□, SGMCS-08D□, SGMCS-17D□, SGMCS-25D□	-	-
			SGDV-04A05A-OY	-	-	SGLGW-40A365□, SGLGW-60A253A□	
		750 W	SGDV-08A01A-OY	SGMAH-08A□, SGMPH-08A□, SGMJV-08A□, SGMAV-08A□, SGMEV-08A□	SGMCS-16E□, SGMCS-35E□	-	-
			SGDV-08A05A-OY	-	-	SGLGW-60A365A□, SGLFW-35A230□, SGLFW-50A200□	
		1.5 kW	SGDV-15A01A-OY	SGMPH-15A□, SGMAV-10A□, SGMEV-15A□	SGMCS-45M□, SGMCS-80M□, SGMCS-80N□	-	-
			SGDV-15A05A-OY	-	-	SGLGW-90A200A□, SGLFW-50A380□, SGLFW-1ZA200□	
		3 phase 400 VAC	0.5 kW	SGDV-05D01A-OY	SGMAH-03D□, SGMPH-04D□, SGMGH-05D□, SGMEV-04D□, SGMGV-05D□	-	-
				SGDV-05D05A-OY	-	-	SGLFW-35D□
	1.0 kW		SGDV-10D01A-OY	SGMAH-07D□, SGMPH-08D□, SGMGH-09D□, SGMSH-10D□, SGMUH-10D□, SGMEV-08D□, SGMGV-09D□, SGMSV-10D□	-	-	-
			SGDV-10D05A-OY	-	-	SGLFW-50D200□, SGLTW-35D170□, SGLTW-50D170□	
	1.5 kW		SGDV-15D01A-OY	SGMPH-15D□, SGMGH-13D□, SGMSH-15D□, SGMUH-15D□, SGMEV-15D□, SGMGV-13D□, SGMSV-15D□	-	-	-
			SGDV-15D05A-OY	-	-	SGLFW-50D380□, SGLFW-1ZD200□	
	2 kW		SGDV-20D01A-OY	SGMGH-20D□, SGMSH-20D□, SGMGV-20D□, SGMSV-20D□	-	-	-
			SGDV-20D05A-OY	-	-	SGLFW-1ED380□, SGLTW-35D320□, SGLTW-50D320□	
	3 kW		SGDV-30D01A-OY	SGMGH-30D□, SGMSH-30D□, SGMUH-30D□, SGMGV-30D□, SGMGV-30D□	-	-	-
SGDV-30D05A-OY			-	-	SGLFW-1ZD380□, SGLFW-1ED560□, SGLTW-40D400□		
5 kW	SGDV-50D01A-OY		SGMGH-44D□, SGMSH-50D□, SGMUH-40D□, SGMGV-44D□, SGMSV-50D□	-	-	-	
	SGDV-50D05A-OY		-	-	SGLTW-40D60□, SGLTW-80D400□		
6 kW	SGDV-210D01A		SGMGH-55D□, SGMGV-55D□	-	-	-	
7.5 kW	SGDV-260D01A		SGMGH-75D□, SGMGV-75D□	-	-	-	
11 kW	SGDV-280D01A	SGMGH-1AD□, SGMGV-1AD□	-	-	-		
15 kW	SGDV-370D01A	SGMGH-1ED□, SGMGV-1ED□	-	-	-		

Control cables (for CN1)

Symbol	Description	Connect to		Model
④	Servo relay unit	CJ1W-NC1□3		XW2B-20J6-1B (1 axis)
		CJ1W-NC2□3/4□3		XW2B-40J6-2B (2 axis)
		CJ1M-CPU22/23		XW2B-20J6-8A (1 axis)
				XW2B-40J6-9A (2 axis)
⑤	Cable to servo drive	Servo relay units XW2B-□0J6-□B	1 m	XW2Z-100J-B4
			2 m	XW2Z-200J-B4
⑥	Position control unit connecting cable	CJ1W-NC113	0.5 m	XW2Z-050J-A14
			1 m	XW2Z-100J-A14
		CJ1W-NC213/413	0.5 m	XW2Z-050J-A15
			1 m	XW2Z-100J-A15
		CJ1W-NC133	0.5 m	XW2Z-050J-A18
			1 m	XW2Z-100J-A18
		CJ1W-NC233/433	0.5 m	XW2Z-050J-A19
			1 m	XW2Z-100J-A19
		CJ1M-CPU22/23	0.5 m	XW2Z-050J-A27
			1 m	XW2Z-100J-A27
⑦	Control cable	For general purpose controllers	1 m	R88A-CPW001S
			2 m	R88A-CPW002S
⑧	Relay terminal block cable	General purpose controller	1 m	R88A-CTW001N
			2 m	R88A-CTW002N
	Relay terminal block		-	XW2B-50G5

Battery backup for absolute encoder (for CN2 encoder cable)

Symbol	Name	Model
⑨	Battery	JZSP-BA01

Note: when the encoder cables with a battery case are used, no battery is required for CN1 (between pin 21 and 22). Battery for CN1 is ER6VCN3.

Cable (for CN5)

Symbol	Name	Model
⑩	Analog monitor cable	R88A-CMW001S
		DE9404559

USB personal computer cable (for CN7)

Symbol	Name	Note
⑪	USB Mini Connector cable	JZSP-CVS06-02-E

Note: double shield USB cable recommended

Cable for Safety Functions (for CN8)

Symbol	Name	Model
⑫	Safety connector with 3 m cable (with Loose Wires at one End)	JZSP-CVH03-03-E

Note: when using the safety function, connect this cable to the safety devices. Even when not using the safety function, use servo drive with the Safe Jumper Connector (JZSP-CVH05-E) connected.

Filters

Symbol	Applicable servo drive	Filter model	Rated current	Rated voltage
⑬	SGDV-A5A□□A-OY,SGDV-01A□□A-OY, SGDV-02A□□A-OY, SGDV-04A□□A-OY	R88A-FI5-1005-RE	5 A	250 VAC single-phase
	SGDV-08A□□A-OY	R88A-FI5-1009-RE	9 A	
	SGDV-15A□□A-OY	R88A-FI5-1016-RE	16 A	
	SGDV-05D□□A-OY, SGDV-10D□□A-OY, SGDV-15D□□A-OY	R88A-FI5-3004-RE	4.3 A	400 VAC three-phase
	SGDV-20D□□A-OY, SGDV-30D□□A-OY	R88A-FI5-3008-RE	8.6 A	
	SGDV-50D□□A-OY	R88A-FI5-3012-RE	14.5 A	

Connectors

Specifications	Model
I/O connector kit (for CN1)	R88A-CNU11C
Sigma-5 drive encoder connector (for CN2)	JZSP-CMP9-1
Safe Jumper Connector	JZSP-CVH05-E

Computer software

Specifications	Model
Configuration and monitoring software tool for servo drives and inverters. (CX-drive version 1.50 or higher)	CX-drive
Complete OMRON software package including CX-drive. (CX-One version 3.0.2 or higher)	CX-One

Ordering information

Sigma-5 MECHATROLINK Servo Drive Configuration

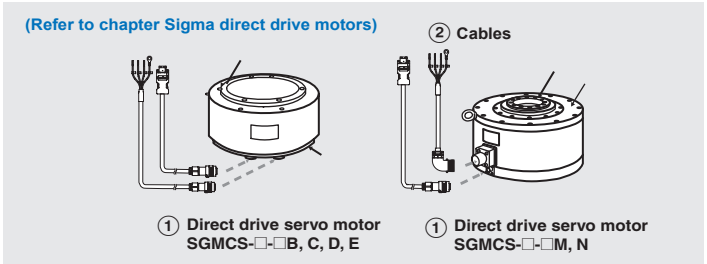
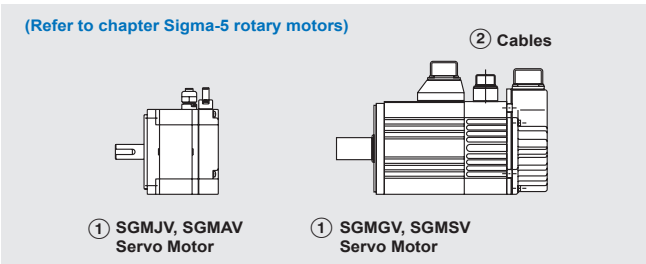
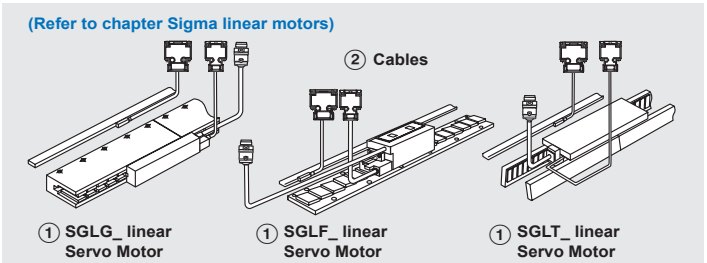
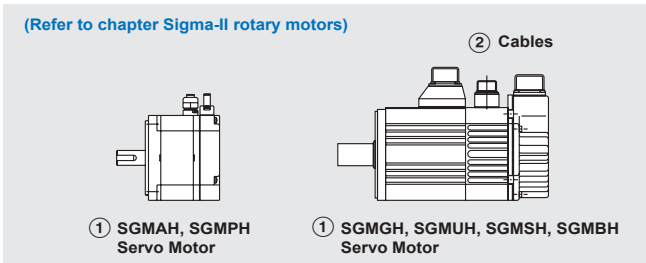
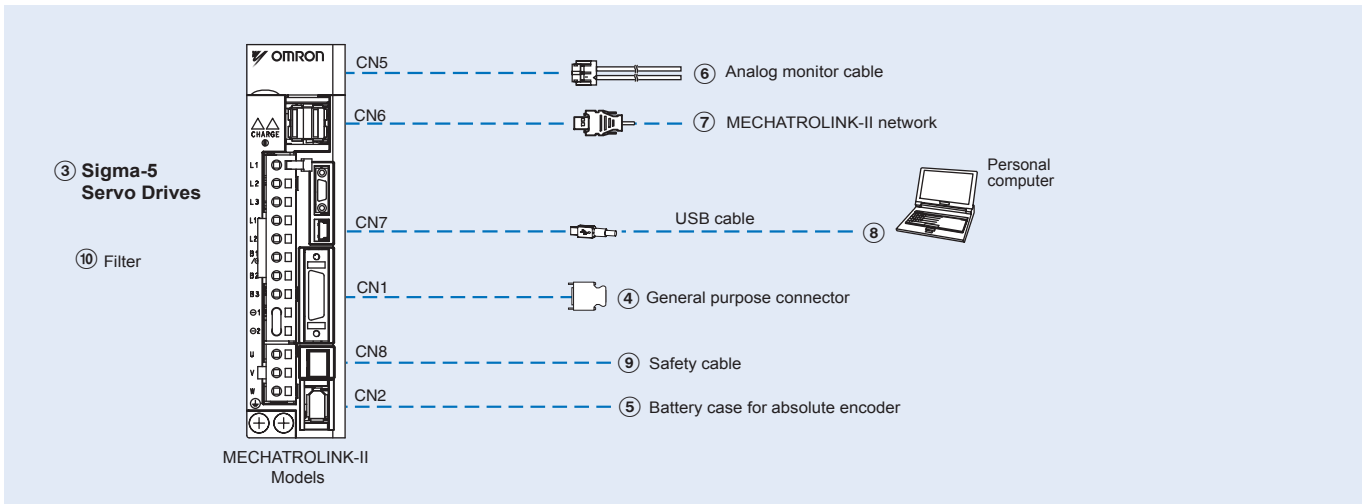

Note: The symbols ①②③④⑤... show the recommended sequence to select the components in a Sigma-5 servo system

Servo motors, power & encoder cables

Note: ①② Refer to the servo motors chapter for detailed motor specifications and selection

Servo drives

Symbol	Specifications	Model	Compatible rotary servo motors ①	Compatible direct drive motors ①	Compatible linear motors ①		
③	1 phase 230 VAC	50 W	SGDV-A5A11A-OY	SGMAH-A5D□, SGMJV-A5A□, SGMAV-A5A□	-	-	
			SGDV-A5A15A-OY	-	-	SGLGW-30A050□	
		100 W	SGDV-01A11A-OY	SGMAH-01A□, SGMPH-01A□, SGMJV-01A□, SGMAV-01A□, SGMEV-01A□	-	-	-
			SGDV-01A15A-OY	-	-	SGLGW-30A080□, SGLGW-40A140□	
		200 W	SGDV-02A11A-OY	SGMAH-02A□, SGMPH-02A□, SGMJV-02A□, SGMAV-02A□, SGMEV-02A□	SGMCS-07B□	-	-
			SGDV-02A15A-OY	-	-	SGLGW-60A140□, SGLGW-40A253□, SGLFW-20A□, SGLFW-35A120□	
		400 W	SGDV-04A11A-OY	SGMAH-04A□, SGMPH-04A□, SGMJV-04A□, SGMAV-04A□, SGMEV-04A□	SGMCS-02B□, SGMCS-05B□, SGMCS-04C□, SGMCS-10C□, SGMCS-14C□, SGMCS-08D□, SGMCS-17D□, SGMCS-25D□	-	-
			SGDV-04A15A-OY	-	-	SGLGW-40A365□, SGLGW-60A253A□	
		750 W	SGDV-08A11A-OY	SGMAH-08A□, SGMPH-08A□, SGMJV-08A□, SGMAV-08A□, SGMEV-08A□	SGMCS-16E□, SGMCS-35E□	-	-
			SGDV-08A15A-OY	-	-	SGLGW-60A365A□, SGLFW-35A230□, SGLFW-50A200□	
	1.5 kW	SGDV-15A11A-OY	SGMPH-15A□, SGMAV-10A□, SGMEV-15A□	SGMCS-45M□, SGMCS-80M□, SGMCS-80N□	-	-	
		SGDV-15A15A-OY	-	-	SGLGW-90A200A□, SGLFW-50A380□, SGLFW-1ZA200□		
	3 phase 400 VAC	0.5 kW	SGDV-05D11A-OY	SGMAH-03D□, SGMPH-04D□, SGMGH-05D□, SGMEV-04D□, SGMGV-05D□	-	-	
			SGDV-05D15A-OY	-	-	SGLFW-35D□	
		1.0 kW	SGDV-10D11A-OY	SGMAH-07D□, SGMPH-08D□, SGMGH-09D□, SGMSH-10D□, SGMUH-10D□, SGMEV-08D□, SGMGV-09D□, SGMSV-10D□,	-	-	-
			SGDV-10D15A-OY	-	-	SGLFW-50D200□, SGLTW-35D170□, SGLTW-50D170□	
		1.5 kW	SGDV-15D11A-OY	SGMPH-15D□, SGMGH-13D□, SGMSH-15D□, SGMUH-15D□, SGMEV-15D□, SGMGV-13D□, SGMSV-15D□	-	-	-
			SGDV-15D15A-OY	-	-	SGLFW-50D380□, SGLFW-1ZD200□	
		2 kW	SGDV-20D11A-OY	SGMGH-20D□, SGMSH-20D□, SGMGV-20D□, SGMSV-20D□	-	-	-
			SGDV-20D15A-OY	-	-	SGLFW-1ED380□, SGLTW-35D320□, SGLTW-50D320□	
3 kW		SGDV-30D11A-OY	SGMGH-30D□, SGMSH-30D□, SGMUH-30D□, SGMGV-30D□, SGMGV-30D□	-	-	-	
		SGDV-30D15A-OY	-	-	SGLFW-1ZD380□, SGLFW-1ED560□, SGLTW-40D400□		
5 kW		SGDV-50D11A-OY	SGMGH-44D□, SGMSH-50D□, SGMUH-40D□, SGMGV-44D□, SGMSV-50D□	-	-	-	
		SGDV-50D15A-OY	-	-	SGLTW-40D60□, SGLTW-80D400□		
6 kW		SGDV-210D11A	SGMGH-55D□, SGMGV-55D□	-	-	-	
7.5 kW		SGDV-260D11A	SGMGH-75D□, SGMGV-75D□	-	-	-	
11 kW	SGDV-280D11A	SGMGH-1AD□, SGMGV-1AD□	-	-	-		
15 kW	SGDV-370D11A	SGMGH-1ED□, SGMGV-1ED□	-	-	-		

Battery backup for absolute encoder (for CN2 encoder cable)

Symbol	Name	Model
⑤	Battery	JZSP-BA01

Note: when the encoder cables with a battery case JZSP-BA01 are used, no battery is required for CN1 (between pin 21 and 22). Battery for CN1 is ER6VCN3.

Cable (for CN5)

Symbol	Name	Model
⑥	Analog monitor cable	R88A-CMW001S
		DE9404559

Mechatrolink-II cables (for CN6)

Symbol	Specifications	Length	Model
⑦	Mechatrolink-II Terminator resistor		JEPMC-W6022
	Mechatrolink-II Cables	0.5 m	JEPMC-W6003-A5
		1 m	JEPMC-W6003-01
		3 m	JEPMC-W6003-03
		5 m	JEPMC-W6003-05
		10 m	JEPMC-W6003-10
		20 m	JEPMC-W6003-20
		30 m	JEPMC-W6003-30

Filters

Symbol	Applicable servo drive	Filter model	Rated current	Rated voltage
⑩	SGDV-A5A□□□A-OY,SGDV-01A□□□A-OY, SGDV-02A□□□A-OY, SGDV-04A□□□A-OY	R88A-FI5-1005-RE	5 A	250 VAC single-phase
	SGDV-08A□□□A-OY	R88A-FI5-1009-RE	9 A	
	SGDV-15A□□□A-OY	R88A-FI5-1016-RE	16 A	
	SGDV-05D□□□A-OY, SGDV-10D□□□A-OY, SGDV-15D□□□A-OY	R88A-FI5-3004-RE	4.3 A	400 VAC three-phase
	SGDV-20D□□□A-OY, SGDV-30D□□□A-OY	R88A-FI5-3008-RE	8.6 A	
	SGDV-50D□□□A-OY	R88A-FI5-3012-RE	14.5 A	

Connectors

Specification	Model
I/O connector kit (for CN1)	R88A-CNW01C
Sigma-5 drive encoder connector (for CN2)	JZSP-CMP9-1
Safe Jumper Connector	JZSP-CVH05-E

Computer software

Specifications	Model
Configuration and monitoring software tool for servo drives and inverters. (CX-drive version 1.50 or higher)	CX-drive
Complete OMRON software package including CX-drive. (CX-One version 3.0.2 or higher)	CX-One

USB personal computer cable (for CN7)

Symbol	Name	Note
⑧	USB Mini Connector cable	JZSP-CVS06-02-E

Note: double shield USB cable recommended

Cable for Safety Functions (for CN8)

Symbol	Name	Model
⑨	Safety connector with 3 m cable (with Loose Wires at one End)	JZSP-CVH03-03-E

Note: when using the safety function, connect this cable to the safety devices. Even when not using the safety function, use servo drive with the Safe Jumper Connector (JZSP-CVH05-E) connected.

ALL DIMENSIONS SHOWN ARE IN MILLIMETERS.
To convert millimeters into inches, multiply by 0.03937. To convert grams into ounces, multiply by 0.03527.