

New!

OMRON

DeviceNet Smart Slaves

Remote I/O Terminals with Transistors

DRT2-ID08(-1)/OD08(-1)/MD16(-1)

MIL Connector Terminals with Transistors

DRT2-ID16ML(-1)/OD16ML(-1)/ID16MLX(-1)/OD16MLX(-1)

Environment-resistive Terminals with Transistors (without detection functions)

DRT2-ID04CL(-1)/OD04CL(-1)/ID08CL(-1)/OD08CL(-1)/
MD16CL(-1)/HD16CL(-1)



Remote Maintenance

The lineup now includes a wide variety of Smart Slaves with different numbers of control points that contribute to production site servicing and repair.



realizing

AUDIN - 8, avenue de la malle - 51370 Saint Brice Courcelles
Tel : 03.26.04.20.21 - Fax : 03.26.04.28.20 - Web : <http://www.audin.fr> - Email : info@audin.fr



Use production site information in a variety of applications, such as maintenance and quality control.

OMRON's DRT2-series Smart Slaves do not just input and output ON/OFF signals. They collect a variety of value-added information to help increase the rate of operation without changing the wiring for existing DeviceNet networks. In particular, they allow the separation of control systems and maintenance systems so that maintenance systems can be created independently of control systems.

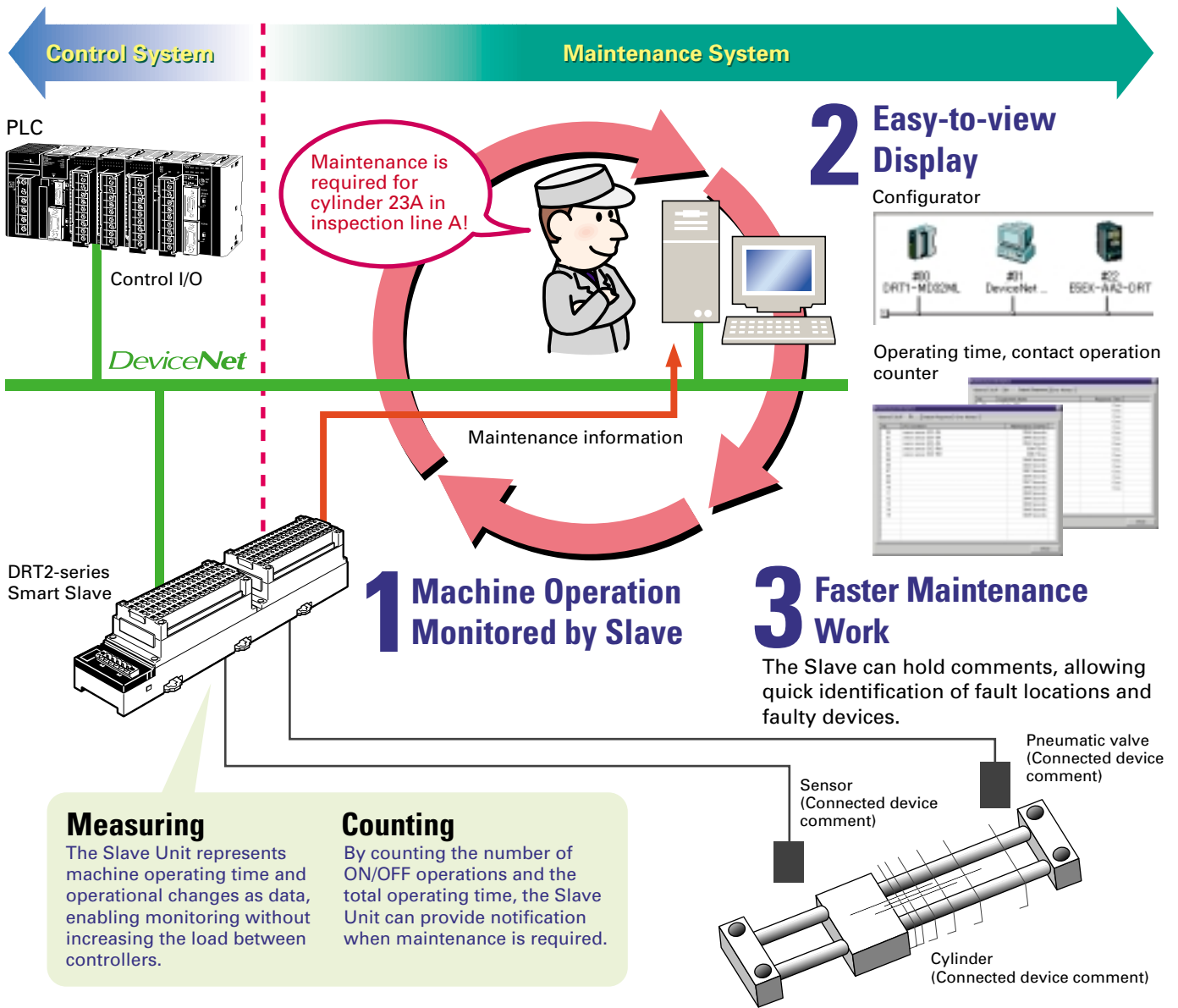

Collect a variety of data from maintenance systems without influencing control systems and productivity.

All data can be converted to electronic format and, by combining with an OMRON PLC (CS/CJ Series), checked directly from Ethernet or the Internet to allow remote maintenance.

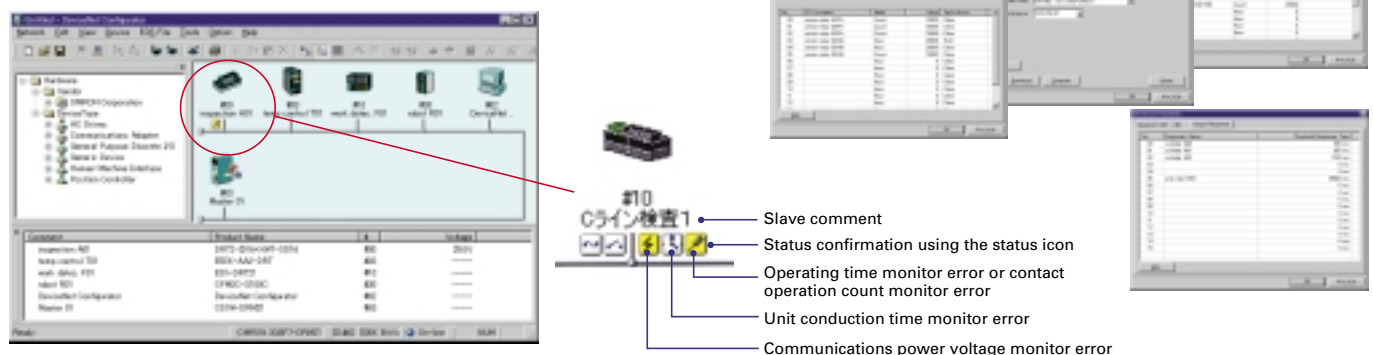

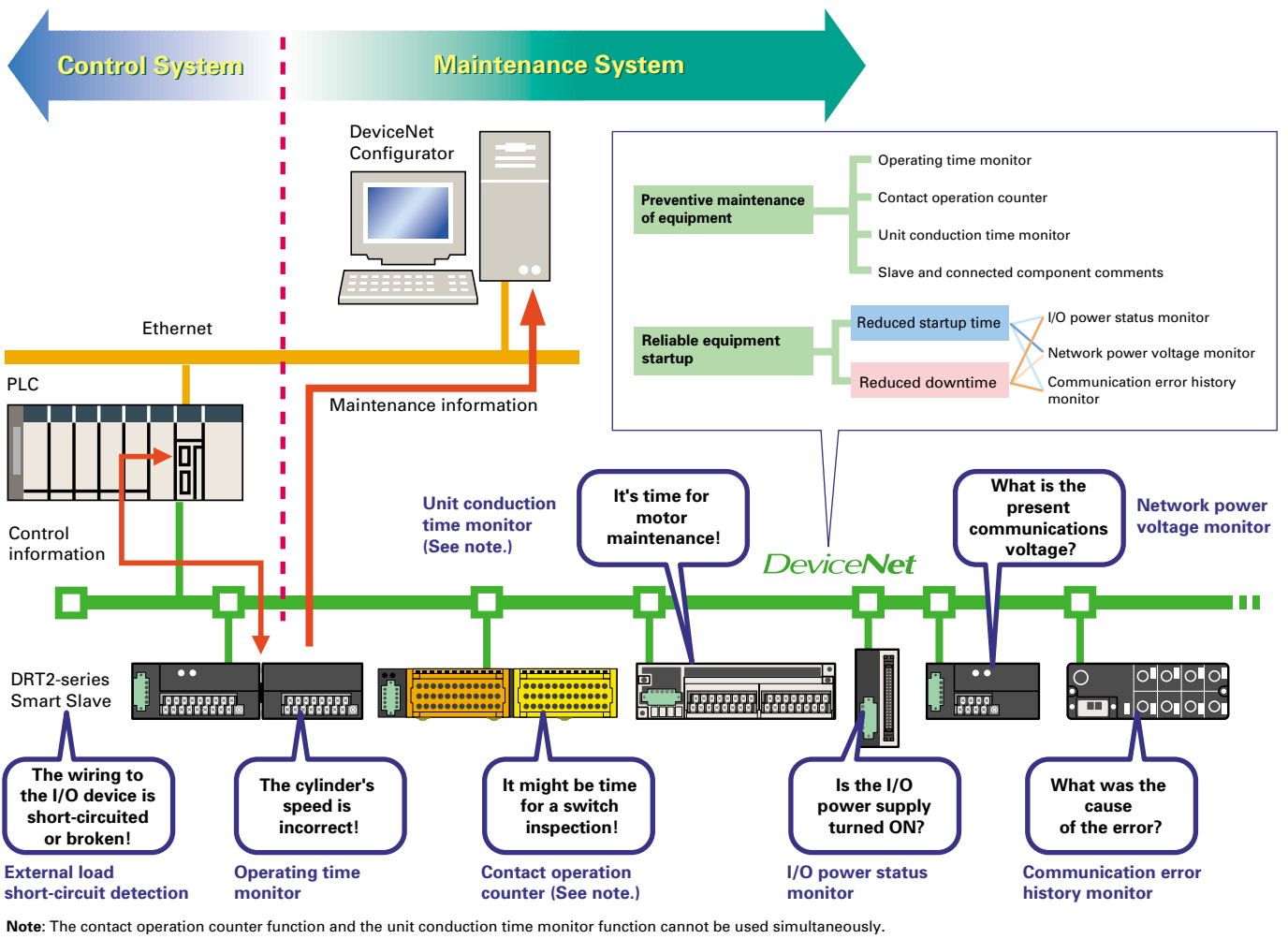

Using OMRON Temperature Input Terminals for Maintenance

Failure Prediction and Maintenance

If prolonging the time it takes to reach a certain temperature may degrade equipment:

The operating time of a preset temperature range is counted in 1-s units.

Slaves can notify the Master when a setting is exceeded.

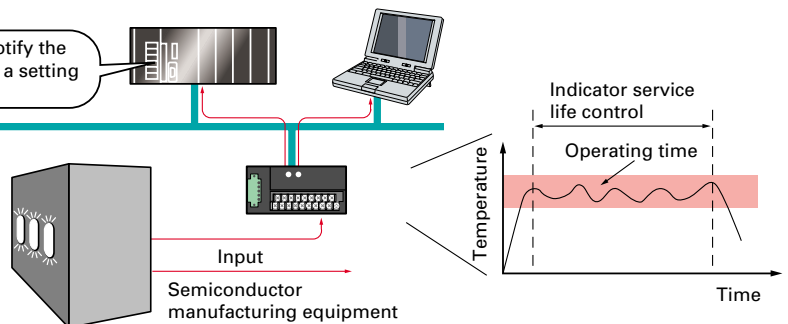

The peaks or valleys of temperature inputs that change in a regular pattern are counted to predict when devices operating with severe temperature swings are due for maintenance.

Short Startup

If it takes too long to modify the ladder program on the Master when a Temperature Sensor is replaced:

Slaves internally convert display values to temperature input values so the Controller program no longer has to be modified to perform this task.

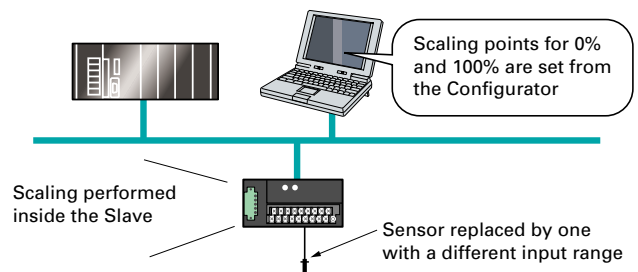

Wide variety of control and maintenance functions using DeviceNet.

Monitor network devices using a DeviceNet Configurator.

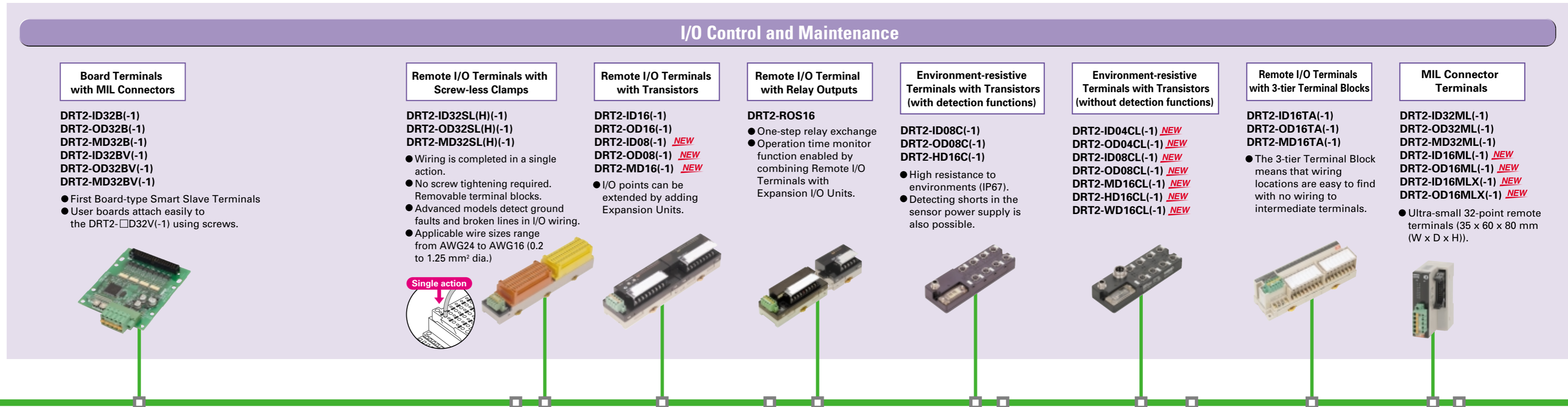
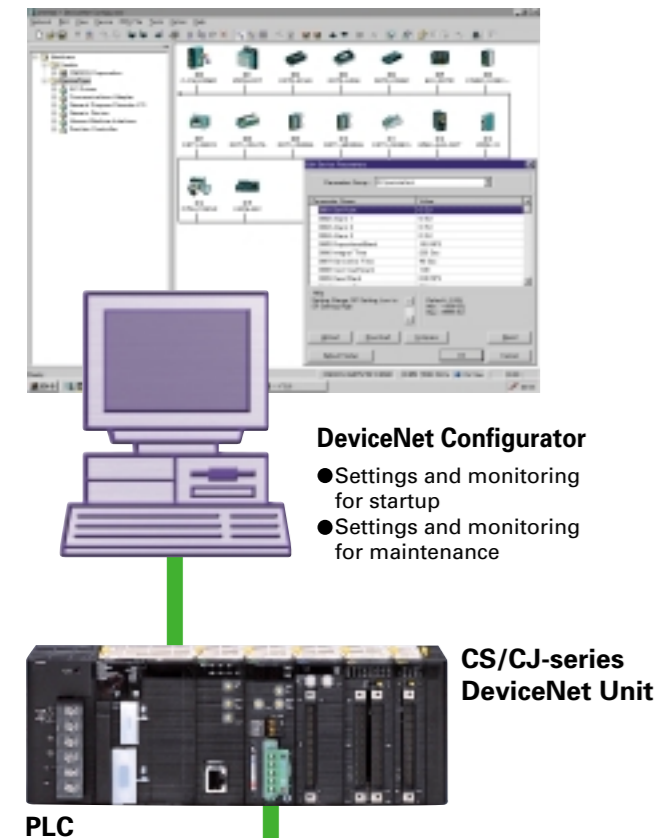

New Lineup

Models with 8 Input, 8 Output, or 16 I/O Points Added to the Lineup

Remote I/O Terminals with Transistors
DRT2-ID08(-1)/OD08(-1)/MD16(-1)

- Collect a variety of data from maintenance systems without influencing control systems and productivity.
- Communications power supply voltage monitor, deterioration due to aging, operating time data, and other information can be easily collected and managed via the network.
- Locations of problems can be easily identified.

Remote I/O Terminals with IP67 High Environmental Resistance

Environment-resistive Terminals with Transistors
DRT2-ID04CL(-1)/OD04CL(-1)/ID08CL(-1)/OD08CL(-1)/MD16CL(-1)/HD16CL(-1)/WD16CL(-1)

- Smart Slave functions provide robust support for effective maintenance and monitoring device operation status.
- The terminals conform to IP67 and use materials selected for resistance to oil and spattering.
- Models with two-output connector are also available to improve ease of connection with hydraulic valve devices.

Terminals with 16 Inputs or Outputs

MIL Connector Terminals with Transistors
DRT2-ID16ML(-1)/OD16ML(-1)/ID16MLX(-1)/OD16MLX(-1)

- Connection with an array of I/O interfaces is achieved by combining adaptor boards for D-Sub or other interfaces.

e-CON Connector Terminals

DRT2-ID16S(-1)
DRT2-MD16S(-1)

- Includes industry-standard e-CON connector that can be used to connect prewired sensors without using special tools. (The OMRON XN2 Connector can be used.)

Sensor Input and Maintenance

Analog I/O Terminals

DRT2-AD04/DRT2-AD04H
DRT2-DA02

- The DRT2-AD04H offers high resolution at 1/30,000 (full scale) and insulation between input channels.
- The DRT2-AD04 and DRT2-DA02 support a wide variety of data sampling function, including scaling, peak/bottom hold, top/valley hold, comparator, integral, and differential operation functions.

Analog Control and Maintenance

Temperature Input Terminals

DRT2-TS04T
DRT2-TS04P

- Offers basically the same functions as Analog Input Terminals, such as scaling and comparators.
- Also provides functions that are available only from Temperature Input Terminals, such as the time in a preset temperature range and temperature difference detection between input channels.

DeviceNet Communications Unit for E5ZN Digital Temperature Controllers

E5ZN-DRT

- Monitoring and setting of Temperature Controller from PLC.
- Batch download of all Temperature Controller parameters from Configurator.

DeviceNet Communications Units/Cards for Inverters

3G3MV-PDRT2 (for 3G3MV Series)
3G3RV-PDRT2 (for 3G3RV Series)

- Frequencies and other specifications can be designated from PLC.
- Monitor-related maintenance possible, including output current (torque) error detection/trace, operation monitor, and general-purpose I/O read.

Monitor Control and Maintenance

Functions Supported by Smart Slaves

Slave name	General-purpose Slaves															General-purpose Slaves						Environment-resistive Slaves						General-purpose Slaves		Analog Slaves			
	Remote I/O Terminals										MIL Connector Terminals			Board Terminals		Screw-less Clamp Terminals						Environment-resistive Terminals						e-con Connector Terminals		Analog I/O Terminals			Temperature Input Terminals
	Models with Transistors					Model with Relay Outputs	Models with 3-tier Terminal Blocks			Models with Transistors			Models with MIL Connectors		Models with Transistors With Detection Functions			Models with Transistors Without Detection Functions			Models with Transistors With Detection Functions			Models with Transistors Without Detection Functions			DRT2-□D16S(-1)		DRT2-AD04	DRT2-AD04H	DRT2-DA02	DRT2-TS04□	
	DRT2-□D16(-1)		DRT2-□D08(-1)		DRT2-MD16(-1)	DRT2-ROS16	DRT2-□D16TA(-1)			DRT2-□D32ML(-1) DRT2-□D16ML(-1) DRT2-□D16MLX(-1)			DRT2-□D32B(-1) DRT2-□D32BV(-1)		DRT2-□D32SLH(-1)			DRT2-□D32SL(-1)			DRT2-□D08C(-1) DRT2-□D16C(-1)			DRT2-□D04CL(-1) DRT2-□D08CL(-1) DRT2-□D16CL(-1)									
Input		Output		Input/output	Output	Input	Output	Input/output	Input	Output	Input/output	Input	Output	Input/output	Input	Output	Input/output	Input	Output	Input/output	Input	Output	Input/output	Input	Input/output	Input	Output	Input					
Operating time monitor	○ (Inputs and outputs only)		---		○	○	○	○	○	○	○	○	○	○	○	○	○	○	○	○	○	○	○	○	○	○	○	○	○				
Contact operation count monitor					○	○	○	○	○	○	○	○	○	○	○	○	○	○	○	○	○	○	○	○	○	○	○	○	○				
Unit conduction time monitor					○	○	○	○	○	○	○	○	○	○	○	○	○	○	○	○	○	○	○	○	○	○	○	○	○				
Total RUN (ON) time monitor					○	○	○	○	○	○	○	○	○	○	○	○	○	○	○	○	○	○	○	○	○	○	○	○	○				
Unit comment					○	○	○	○	○	○	○	○	○	○	○	○	○	○	○	○	○	○	○	○	○	○	○	○	○				
Connected device comment					○	○	○	○	○	○	○	○	○	○	○	○	○	○	○	○	○	○	○	○	○	○	○	○	○				
Network power voltage monitor					○	○	○	○	○	○	○	○	○	○	○	○	○	○	○	○	○	○	○	○	○	○	○	○	○				
I/O power status monitor			○		---	○	○	○	○	○	○	○	○	○	○	○	○	○	○	○	○	○	○	○	○	○	○	○	○				
Communications error history monitor					○	○	○	○	○	○	○	○	○	○	○	○	○	○	○	○	○	○	○	○	○	○	○	○	○				
Input filter	○	---	○	---	○	---	○	---	○	---	○	---	○	---	○	---	○	---	○	---	○	---	○	---	○	---	○	---	○				
Prevention of malfunctions due to sensor inrush current	○	---	○	---	○	---	○	---	○	---	○	---	○	---	○	---	○	---	○	---	○	---	○	---	○	---	○	---	○				
Sensor power short-circuit detection					---	---	---	---	---	---	---	---	---	---	○	---	○	---	---	---	○	---	---	---	---	---	---	---	---				
External load short-circuit detection					---	---	---	---	---	---	---	---	---	---	---	○ (See note.)	---	---	---	---	---	○	---	---	---	---	---	---	---				
Sensor disconnection detection					---	---	---	---	---	---	---	---	---	---	○	---	○	---	---	---	○	---	---	---	---	---	---	---	---				
External load disconnection detection					---	---	---	---	---	---	---	---	---	---	---	○	○	---	---	---	---	---	---	---	---	---	---	---	---				
Removable terminal blocks					○	---	---	---	---	---	---	---	---	---	---	---	○	---	---	---	---	---	---	---	---	○	---	---					
Automatic baud rate detection					○	---	---	---	---	---	---	---	---	---	---	---	---	---	---	---	---	---	---	---	---	○	---	---					
Unit power supply wiring not required					○	---	---	---	---	---	---	---	---	---	---	---	---	---	---	---	---	---	---	---	---	○	---	---					
Power supply wiring not required for input devices					---	---	---	---	---	---	---	---	---	---	---	---	---	---	---	---	---	---	---	---	---	---	○	---					
Expansion I/O Units mountable	○	---	○	---	○	---	○	---	○	---	○	---	○	---	○	---	○	---	○	---	○	---	○	---	○	---	○	---	○				
Scaling					---	---	---	---	---	---	---	---	---	---	---	---	---	---	---	---	---	---	---	---	---	---	---	---	---				
User calibration					---	---	---	---	---	---	---	---	---	---	---	---	---	---	---	---	---	---	---	---	---	---	---	---	---				
Last maintenance date					○	---	---	---	---	---	---	---	---	---	---	---	---	---	---	---	---	---	---	---	---	---	---	---	---				
Integral function					---	---	---	---	---	---	---	---	---	---	---	---	---	---	---	---	---	---	---	---	---	---	---	---	---				
Moving average processing					---	---	---	---	---	---	---	---	---	---	---	---	---	---	---	---	---	---	---	---	---	---	○	---	---				
Number of AD conversion points setting (conversion cycle)					---	---	---	---	---	---	---	---	---	---	---	---	---	---	---	---	---	---	---	---	---	---	---	---	---				
Peak/bottom hold					---	---	---	---	---	---	---	---	---	---	---	---	---	---	---	---	---	---	---	---	---	---	○	---	---				
Top/valley hold					---	---	---	---	---	---	---	---	---	---	---	---	---	---	---	---	---	---	---	---	---	---	○	---	---				
Change rate calculations					---	---	---	---	---	---	---	---	---	---	---	---	---	---	---	---	---	---	---	---	---	---	○	---	---				
Comparator function					---	---	---	---	---	---	---	---	---	---	---	---	---	---	---	---	---	---	---	---	---	---	○	---	---				
Setting output value for errors					---	---	---	---	---	---	---	---	---	---	---	---	---	---	---	---	---	---	---	---	---	---	---	○	---				
Top/valley count					---	---	---	---	---	---	---	---	---	---	---	---	---	---	---	---	---	---	---	---	---	---	---	---	○				
Operating time in a preset temperature range					---	---	---	---	---	---	---	---	---	---	---	---	---	---	---	---	---	---	---	---	---	---	---	---	○				
Temperature difference detection between input channels					---	---	---	---	---	---	---	---	---	---	---	---	---	---	---	---	---	---	---	---	---	---	---	---	○				

○: Yes, ---: No

Note: The contact operation count monitor and the total RUN (ON) time monitor cannot be used at the same time for one contact. External load detection is supported only by the DRT2-MD32SLH-1 and DRT2-OD32SLH-1.

Specifications

Communications power supply voltage	11 to 25 VDC (supplied from communications connector)	
I/O power supply voltage	20.4 to 26.4 VDC (24 VDC -15% to +10%)	
Noise immunity	Conforms to IEC61000-4-4, 2 kV (power lines)	
Vibration resistance	10 to 60 Hz, 0.7-mm double amplitude, 60 to 150 Hz, 50 ms ² for 80 min each in the X, Y, and Z directions	
Shock resistance	150m/s ² , 6 directions, 3 times each	
Dielectric strength	500 VAC (between isolated circuits)	
Insulation resistance	20 MΩ min. (between isolated circuits)	
Ambient operating temperature	-10 to 55°C	
Ambient operating humidity	25 to 85%	
Ambient operating atmosphere	No corrosive gases	
Ambient storage temperature	-20 to 65°C	
Degree of protection	IP67	
Mounting method	DRT2-□D08□-1/□D16(-1): DRT2-□D32ML(-1)/□D16ML(-1): DRT2-□D04CL(-1)/□D08CL(-1)/□D16CL(-1):	35-mm DIN Track 35-mm DIN Track M5 screws mounting (front or back)
Screw tightening torque	DRT2-□D08(-1)/□D16(-1): DRT2-□D32ML(-1)/□D16ML(-1): DRT2-□D04CL(-1)/□D08CL(-1)/□D16CL(-1):	M3 (power supply and I/O terminals): 0.3 to 0.5 N-m M2 (communications connector screws): 0.26 to 0.3 N-m, M3 (screw terminals): 0.3 to 0.5N-m Round connectors (communications connector, power supply, and I/O): 0.39 to 0.49 N-m M5 (Unit mounting from the front): 1.47 to 1.96 N-m

Input Specifications

Remote I/O Terminals with Transistors

Terminals with 8 Inputs

Item	Model	DRT2-ID08(-1)
Input current		6.0 mA max. per point at 24 VDC
ON delay time		1.5 ms max.
OFF delay time		1.5 ms max.
ON voltage	NPN	15 VDC min. (between each input terminal and V)
	PNP	15 VDC min. (between each input terminal and G)
OFF voltage	NPN	5 VDC max. (between each input terminal and V)
	PNP	5 VDC min. (between each input terminal and G)
OFF current		1.0 mA max.
Isolation method		Photocoupler isolation
Input indicator		Yellow LED indicator

Terminals with 8 Inputs/8 Outputs

Item	Model	DRT2-MD16	DRT2-MD16-1
Internal I/O common		NPN	PNP
Number of I/O points		8 inputs	
ON voltage		15 VDC min. (between each input terminal and V)	15 VDC min. (between each input terminal and G)
		5 VDC max. (between each input terminal and V)	5 VDC min. (between each input terminal and G)
OFF current		1 mA max.	
Input current		6.0 mA max. per point at 24 VDC	3.0 mA max. per point at 17 VDC
		1.5 ms max.	1.5 ms max.
ON delay time		1.5 ms max.	
OFF delay time		1.5 ms max.	
Number of points per common		8 points per common	

MIL Connector Terminals with Transistors

Terminals with 16 Inputs, with Connectors

Item	Model	DRT2-ID16ML DRT2-ID16MLX	DRT2-ID16ML-1 DRT2-ID16MLX-1
Internal I/O common		NPN	PNP
Number of I/O points		16 inputs	
ON voltage		17 VDC min. (between each input terminal and V)	17 VDC min. (between each input terminal and G)
		5 VDC max. (between each input terminal and V)	15 VDC min. (between each input terminal and G)
OFF current		1 mA max.	
Input current		6.0 mA max. per point at 24 VDC	3.0 mA max. per point at 17 VDC
		1.5 ms max.	1.5 ms max.
ON delay time		1.5 ms max.	
OFF delay time		1.5 ms max.	
Max. number of simultaneous ON input points		16	
Number of points per common		16 points per common	

Standard Environment-resistive Terminals and Environment-resistive Terminals with Transistors

Terminals with 4 Inputs

Item	Model	DRT2-ID04CL	DRT2-ID04CL-1
Internal I/O common		NPN	PNP
Number of I/O points		4 inputs	
ON voltage		15 VDC min. (between each input terminal and V)	15 VDC min. (between each input terminal and G)
		5 VDC max. (between each input terminal and V)	5 VDC min. (between each input terminal and G)
OFF current		1 mA max.	
Input current		6.0 mA max. per point at 24 VDC	3.0 mA max. per point at 17 VDC
		20.4 to 26.4 VDC (24 VDC, -15 to +10%)	1.5 ms max.
ON delay time		1.5 ms max.	
OFF delay time		1.5 ms max.	
Number of points per common		4 points per common	

Terminals with 8 Inputs

Item	Model	DRT2-ID08CL	DRT2-ID08CL-1
Internal I/O common		NPN	PNP
Number of I/O points		8 inputs	
ON voltage		15 VDC min. (between each input terminal and V)	15 VDC min. (between each input terminal and G)
		5 VDC max. (between each input terminal and V)	5 VDC min. (between each input terminal and G)
OFF current		1 mA max.	
Input current		6.0 mA/6.0 mA max. per point at 24 VDC	3.0 mA max. per point at 17 VDC
		20.4 to 26.4 VDC (24 VDC, -15 to +10%)	1.5 ms max.
ON delay time		1.5 ms max.	
OFF delay time		1.5 ms max.	
Number of points per common		8 points per common	

Terminals with 16 Inputs

Item	Model	DRT2-HD16CL	DRT2-HD16CL-1
Internal I/O common		NPN	PNP
Number of I/O points		16 inputs	
ON voltage		15 VDC min. (between each input terminal and V)	15 VDC min. (between each input terminal and G)
		5 VDC max. (between each input terminal and V)	15 VDC min. (between each input terminal and G)
OFF current		1 mA max.	
Input current		6.0 mA max. per point at 24 VDC	3.0 mA max. per point at 17 VDC
		20.4 to 26.4 VDC (24 VDC, -15 to +10%)	1.5 ms max.
ON delay time		1.5 ms max.	
OFF delay time		1.5 ms max.	
Number of points per common		16 points per common	

Terminals with 8 Inputs/8 Outputs

Item	Model	DRT2-MD16CL	DRT2-MD16CL-1
Internal I/O common		NPN	PNP
Number of I/O points		8 inputs	
ON voltage		15 VDC min. (between each input terminal and V)	15 VDC min. (between each input terminal and G)
		5 VDC max. (between each input terminal and V)	5 VDC min. (between each input terminal and G)
OFF current		1 mA max.	
Input current		6.0 mA max. per point at 24 VDC	3.0 max. per point at 17 VDC
		20.4 to 26.4 VDC (24 VDC, -15 to +10%)	1.5 ms max.
ON delay time		1.5 ms max.	
OFF delay time		1.5 ms max.	
Number of points per common		8 points per common	

Output Specifications

Remote I/O Terminals with Transistors

Terminals with 8 Outputs

Item	Model	DRT2-OD08(-1)	
Rated output current		0.5 A per point, 4.0 A per common	
ON delay time		0.5 ms max.	
OFF delay time		1.5 ms max.	
Residual voltage		1.2 V max.	
Leakage current		0.1 mA max.	
Isolation method		Photocoupler isolation	
Output indicator		Yellow LED indicator	

Terminals with 8 Inputs/8 Outputs

Item	Model	DRT2-MD16	DRT2-MD16-1
Internal I/O common		NPN	PNP
Number of I/O points		8 outputs	
Rated output current		0.5 A per point, 4 A per common	
Residual voltage		1.2 V max. (0.5 A DC between each output terminal and G)	1.2 V max. (0.5 A DC between each output terminal and V)
Leakage current		0.1 mA max.	
ON delay time		0.5 ms max.	
OFF delay time		1.5 ms max.	
Number of points per common		8 points per common	

MIL Connector Terminals with Transistors

Terminals with 16 Outputs, with Connectors

Item	Model	DRT2-OD16ML DRT2-OD16MLX	DRT2-OD16ML-1 DRT2-OD16MLX-1
Internal I/O common		NPN	PNP
Number of I/O points		16 outputs	
Rated output current		0.3 A per point, 2 A per common (See note.)	
Residual voltage		1.2 V max. (0.3 A DC between each output terminal and G)	1.2 V max. (0.3 A DC between each output terminal and V)
Leakage current		0.1 mA max.	
ON delay time		0.5 ms max.	
OFF delay time		1.5 ms max.	
Number of points per common		16 points per common	

Note: Make sure the total external load current does not exceed 2 A.
Make sure that the V and G terminals do not exceed 1 A per terminal.

Standard Environment-resistive Terminals and Environment-resistive Terminals with Transistors

Terminals with 4 Outputs

Item	Model	DRT2-OD04CL	DRT2-OD04CL-1
Internal I/O common		NPN	PNP
Number of I/O points		4 outputs	
Rated output current		0.5 A per point, 4 A per common	
Residual voltage		1.2 V max. (0.5 A DC between each output terminal and G)	1.2 V max. (0.5 A DC between each output terminal and V)
Leakage current		0.1 mA max.	
I/O power supply voltage		20.4 to 26.4 VDC (24 VDC, -15 to +10%)	
ON delay time		0.5 ms max.	
OFF delay time		1.5 ms max.	
Number of points per common		4 points per common	

Terminals with 8 Outputs

Item	Model	DRT2-OD08CL	DRT2-OD08CL-1
Internal I/O common		NPN	PNP
Number of I/O points		8 outputs	
Rated output current		0.5 A per point, 4 A per common	
Residual voltage		1.2 V max. (0.5 A DC between each output terminal and G)	1.2 V max. (0.5 A DC between each output terminal and V)
Leakage current		0.1 mA max.	
I/O power supply voltage		20.4 to 26.4 VDC (24 VDC, -15 to +10%)	
ON delay time		0.5 ms max.	
OFF delay time		1.5 ms max.	
Number of points per common		8 points per common	

Terminals with 16 Outputs

Item	Model	DRT2-WD16CL	DRT2-WD16CL-1
Internal I/O common		NPN	PNP
Number of I/O points		16 outputs	
Rated output current		0.5 A per point, 4 A per common	
Residual voltage		1.2 V max. (0.5 A DC between each output terminal and G)	1.2 V max. (0.5 A DC between each output terminal and V)
Leakage current		0.1 mA max.	
I/O power supply voltage		20.4 to 26.4 VDC (24 VDC, -15 to +10%)	
ON delay time		0.5 ms max.	
OFF delay time		1.5 ms max.	
Number of points per common		16 points per common	

Terminals with 8 Inputs/8 Outputs

Item	Model	DRT2-MD16CL	DRT2-MD16CL-1
Internal I/O common		NPN	PNP
Number of I/O points		8 outputs	
Rated output current		0.5 A per point, 4 A per common	
Residual voltage		1.2 V max. (0.5 A DC between each output terminal and G)	1.2 V max. (0.5 A DC between each output terminal and V)
Leakage current		0.1 mA max.	
I/O power supply voltage		20.4 to 26.4 VDC (24 VDC, -15 to +10%)	
ON delay time		0.5 ms max.	
OFF delay time		1.5 ms max.	
Number of points per common		8 points per common	

Internal Circuit Configuration

Remote I/O Terminals with Transistors

DRT2-ID08 (NPN)

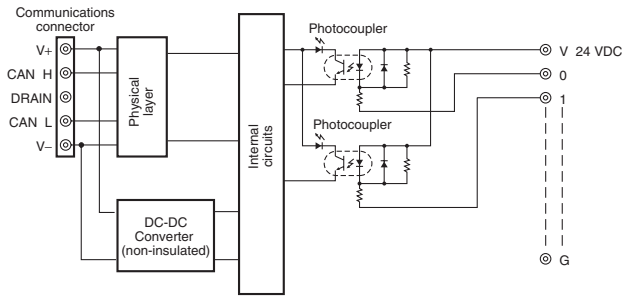

DRT2-ID08-1 (PNP)

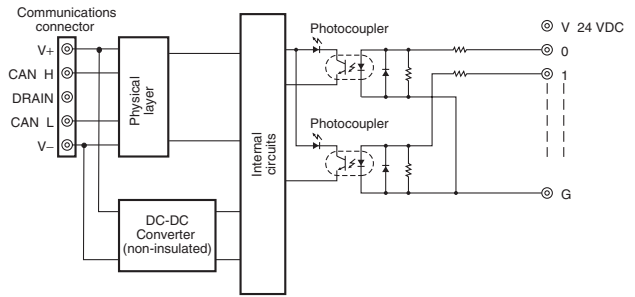

DRT2-OD08 (NPN)

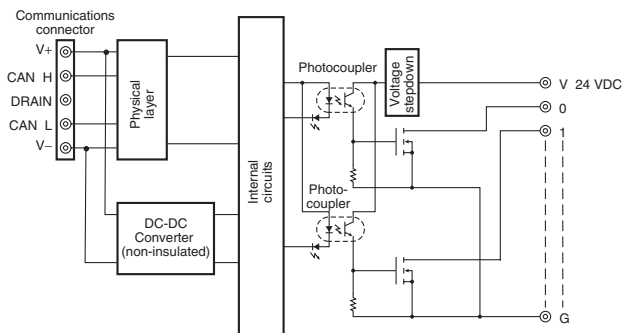

DRT2-OD08-1 (PNP)

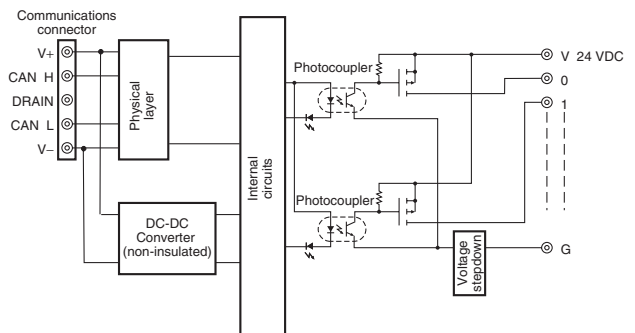

DRT2-MD16 (NPN)

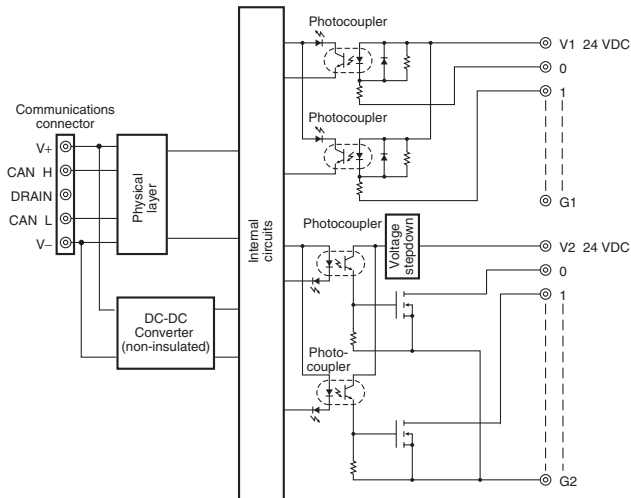

DRT2-MD16-1 (PNP)

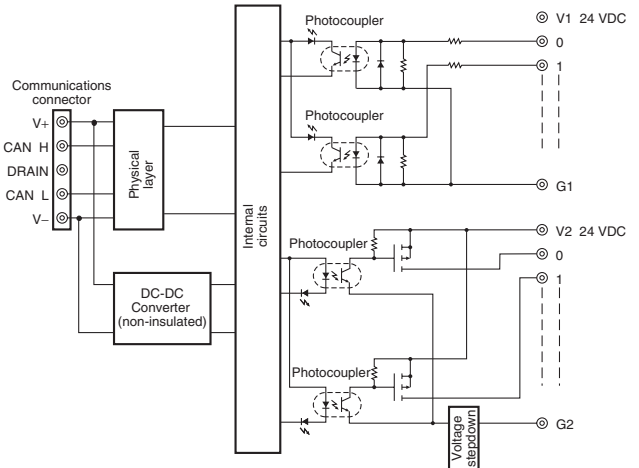

■ MIL Connector Terminals with Transistors

DRT2-ID16ML(X)

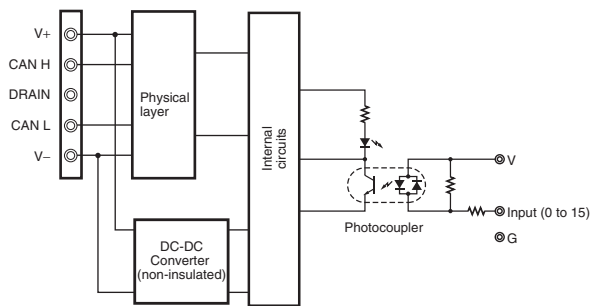

DRT2-ID16ML(X)-1

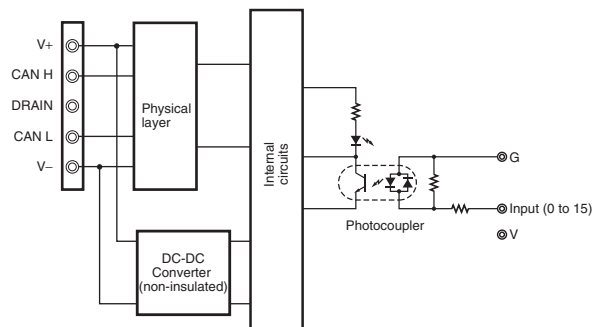

DRT2-OD16ML(X)

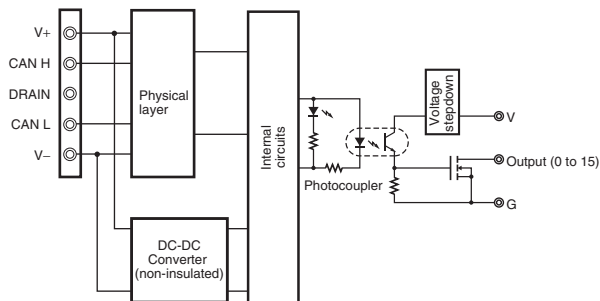

DRT2-OD16ML(X)-1

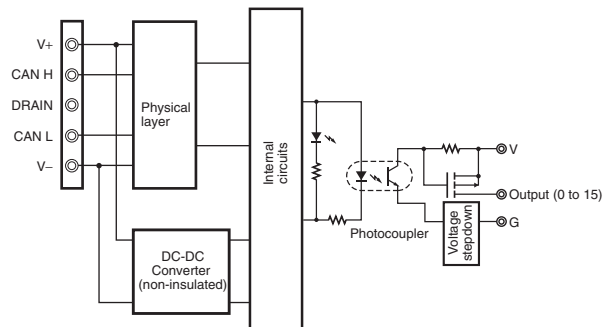

■ Standard Environment-resistive Terminals and Environment-resistive Terminals with Transistors

DRT2-ID04CL (NPN)

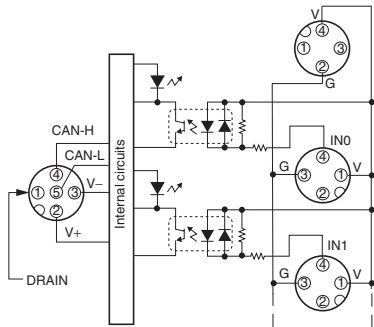

DRT2-ID04CL-1 (PNP)

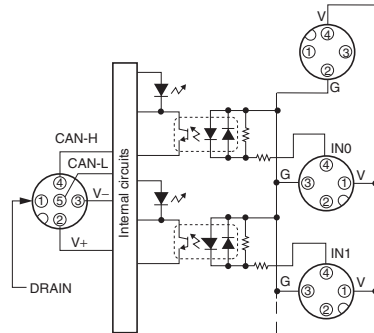

DRT2-OD04CL (NPN)

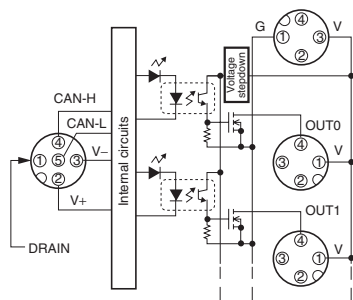

DRT2-OD04CL-1 (PNP)

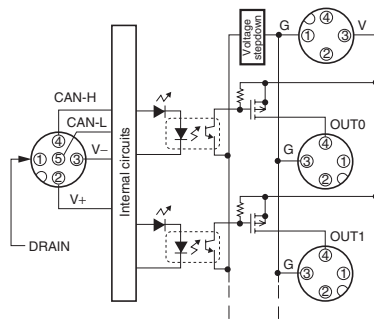

DRT2-ID08CL (NPN)

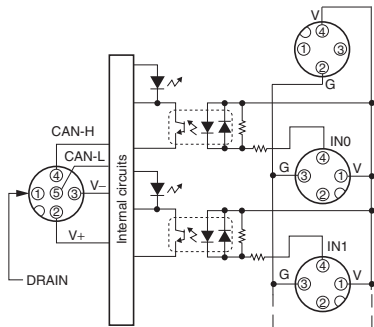

DRT2-ID08CL-1 (PNP)

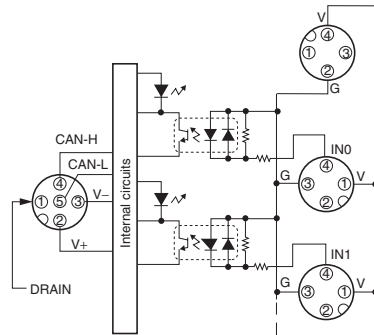

DRT2-OD08CL (NPN)

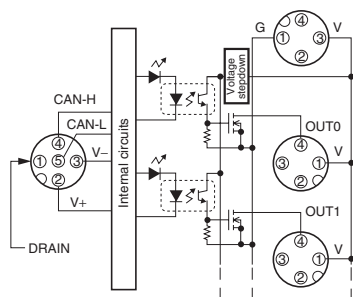

DRT2-OD08CL-1 (PNP)

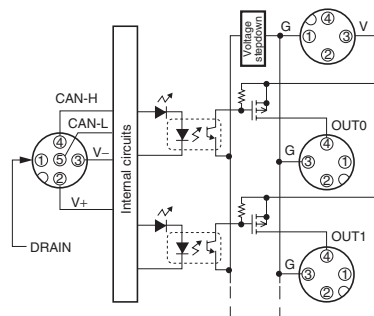

DRT2-HD16CL (NPN)

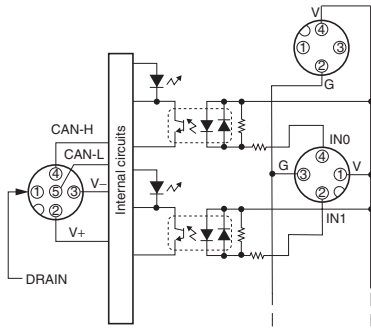

DRT2-HD16CL-1 (PNP)

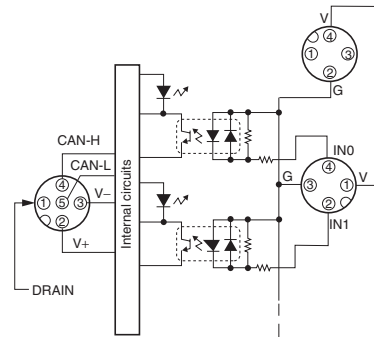

DRT2-WD16CL (NPN)

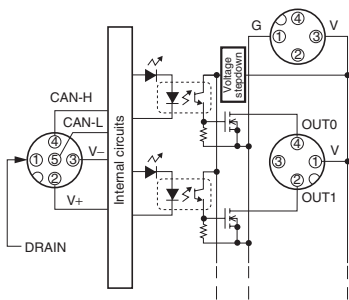

DRT2-WD16CL-1 (PNP)

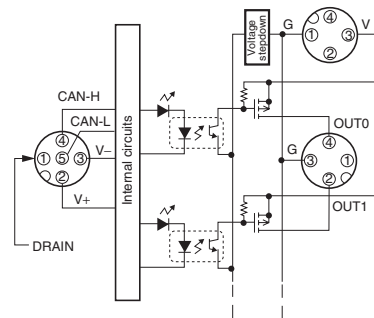

DRT2-MD16CL (NPN)

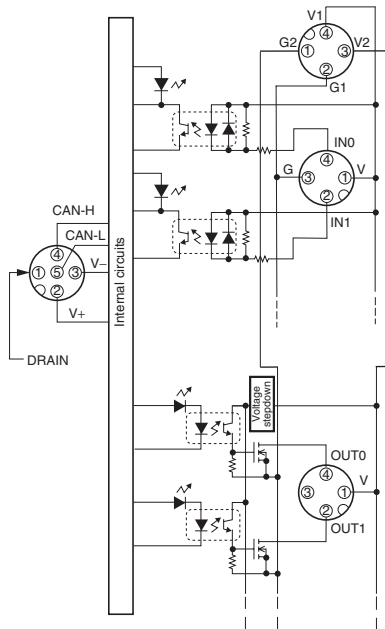

DRT2-MD16CL-1 (PNP)

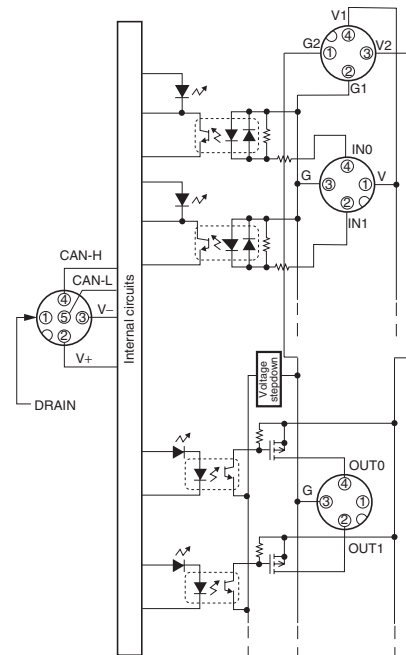

Dimensions

■ Remote I/O Terminals with Transistors

● Remote I/O Terminals

- DRT2-ID08(-1)
- DRT2-OD08(-1)
- DRT2-MD16(-1)

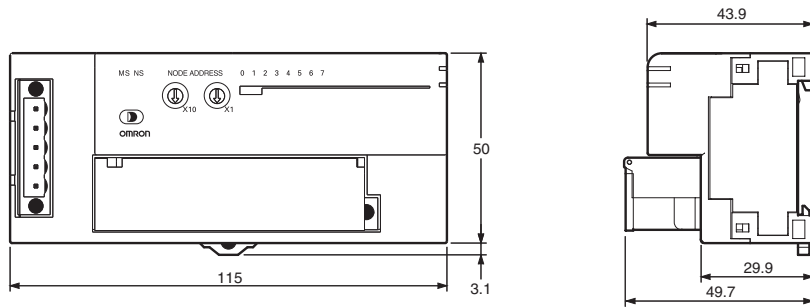

■ MIL Connector Terminals with Transistors

- DRT2-ID16ML(-1)
- DRT2-OD16ML(-1)
- DRT2-ID16MLX(-1)
- DRT2-OD16MLX(-1)

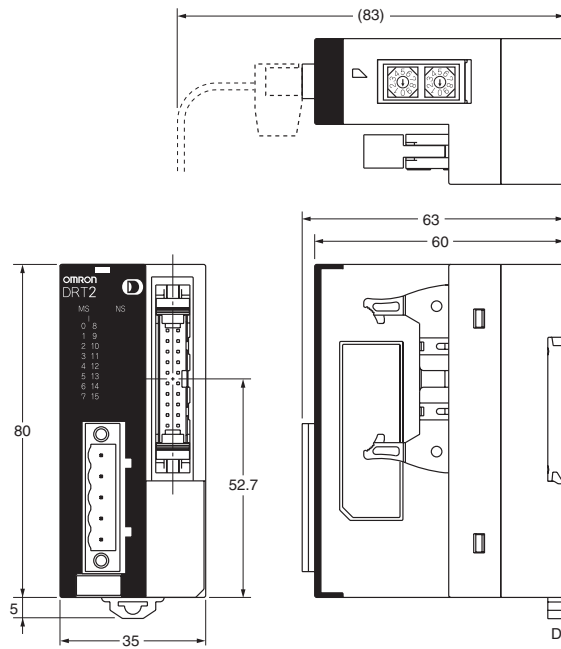

Dimensions inside parentheses are for reference only.

■ Standard Environment-resistive Terminals and Environment-resistive Terminals with Transistors

- DRT2-ID04CL(-1)
- DRT2-OD04CL(-1)

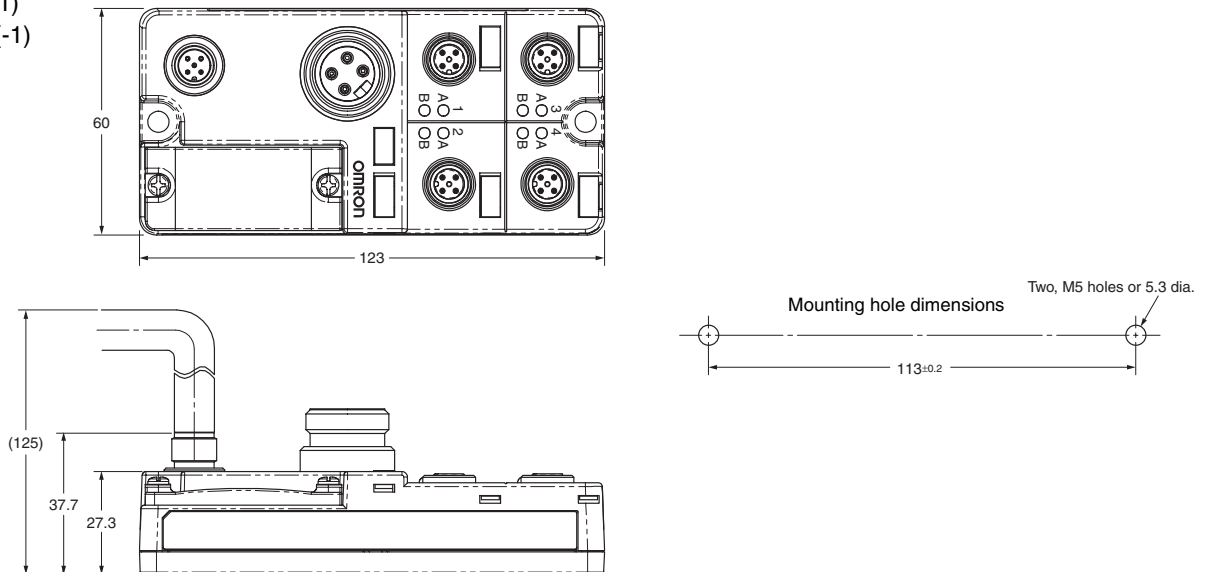

- DRT2-ID08CL(-1)
- DRT2-OD08CL(-1)
- DRT2-HD16CL(-1)
- DRT2-WD16CL(-1)
- DRT2-MD16CL(-1)

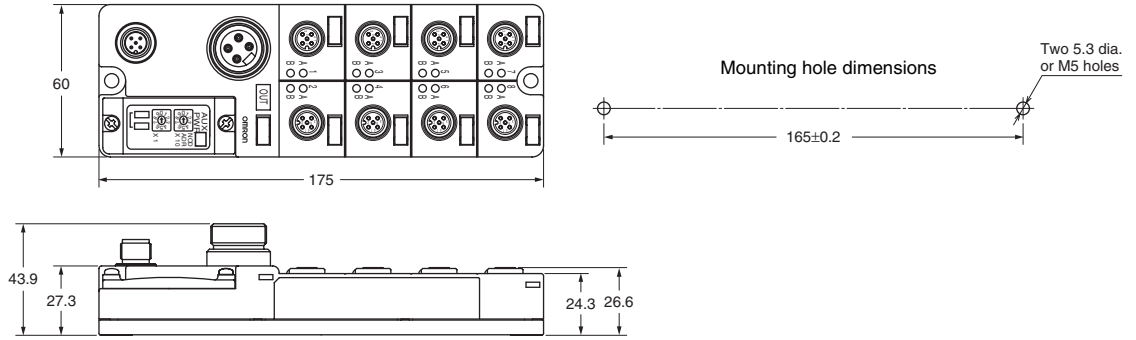

Wiring Diagrams

Remote I/O Terminals with Transistors

DRT2-MD16 (NPN)

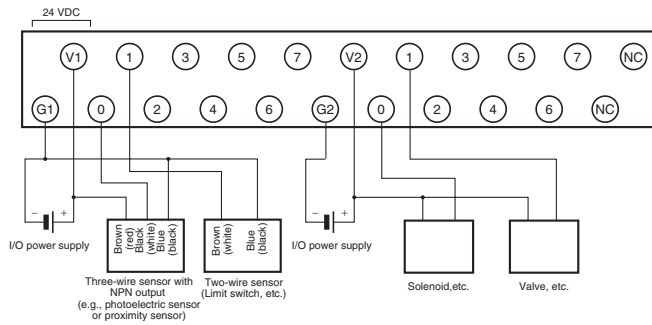

DRT2-MD16-1 (PNP)

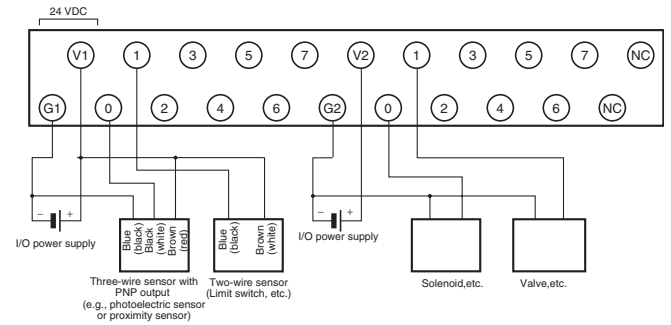

DRT2-ID08 (NPN)

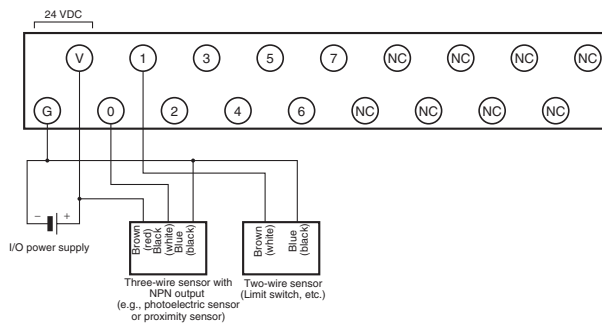

DRT2-ID08-1 (PNP)

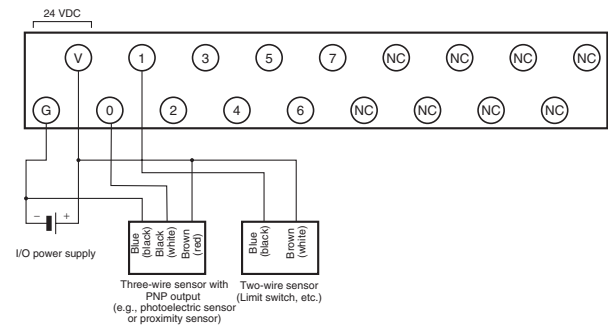

DRT2-OD08 (NPN)

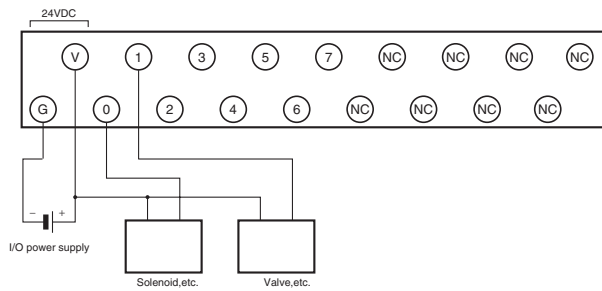

DRT2-OD08-1 (PNP)

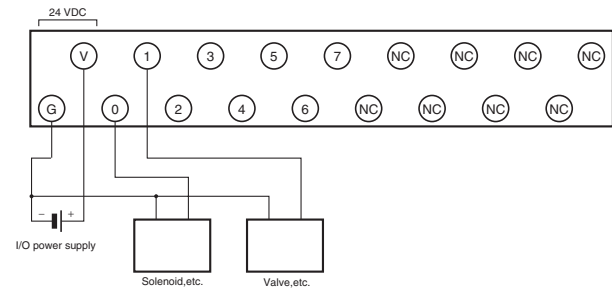

■ MIL Connector Terminals with Transistors

DRT2-ID16ML(X)

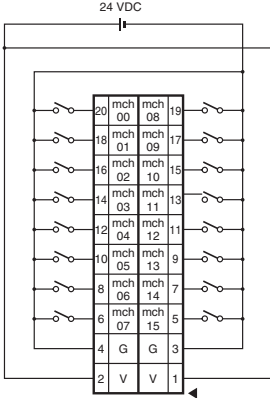

DRT2-ID16ML(X)-1

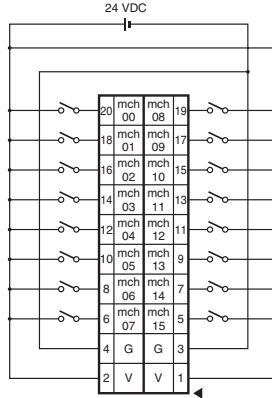

DRT2-ID16MLX(-1)/DRT2-OD16MLX(-1)
Wiring Diagram for Enclosed Cable (with Connectors)

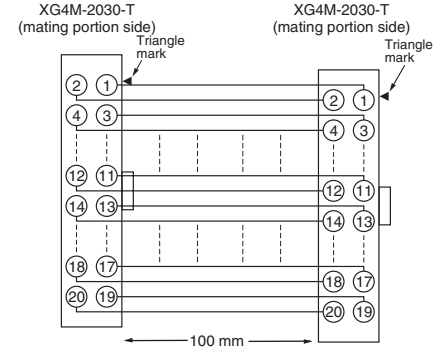

DRT2-OD16ML(X)

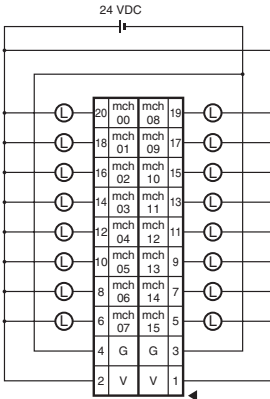

DRT2-OD16ML(X)-1

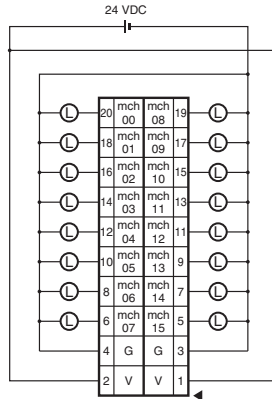

■ Standard Environment-resistive Terminals and Environment-resistive Terminals with Transistors
DRT2-ID04CL (NPN)

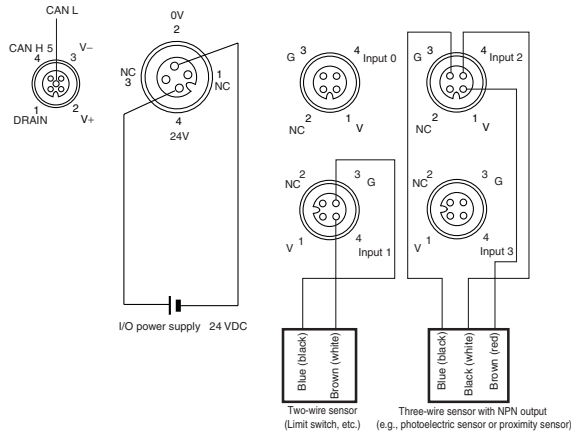

DRT2-ID04CL-1 (PNP)

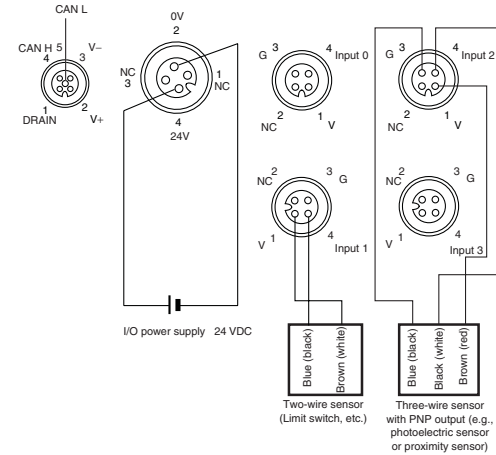

DRT2-OD04CL (NPN)

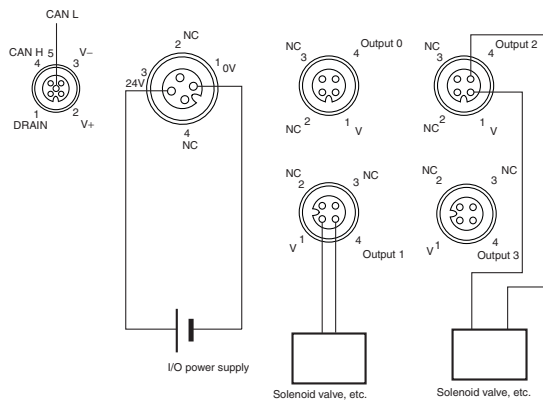

DRT2-OD04CL-1 (PNP)

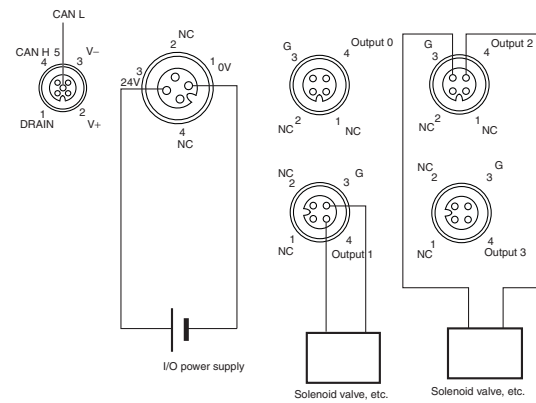

DRT2-ID08CL (NPN)

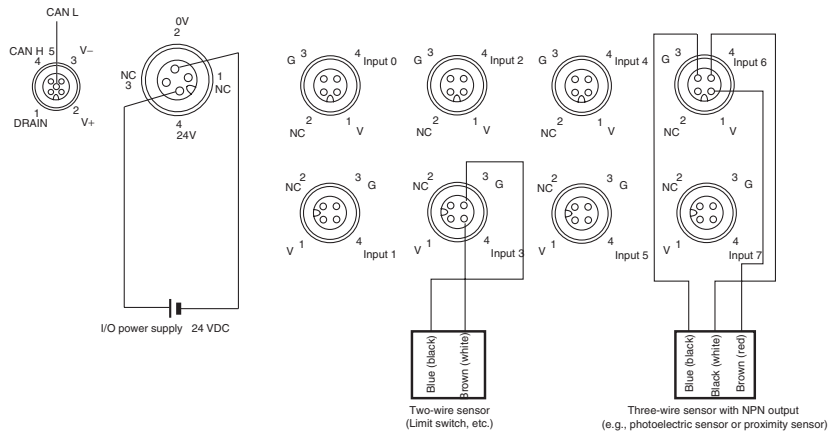

DRT2-ID08CL-1 (PNP)

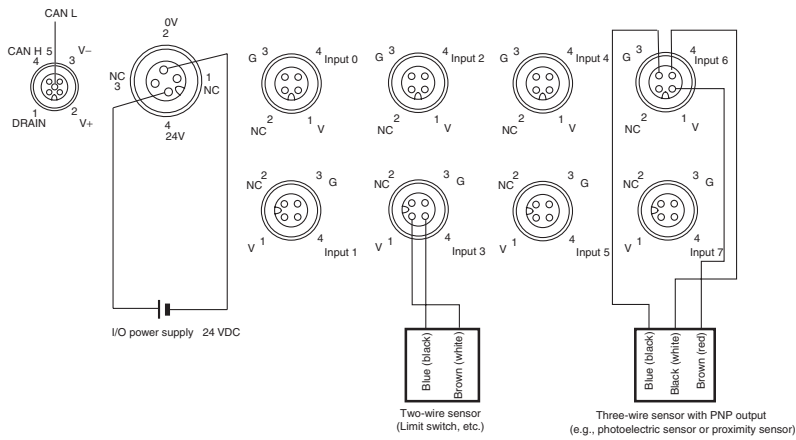

DRT2-OD08CL (NPN)

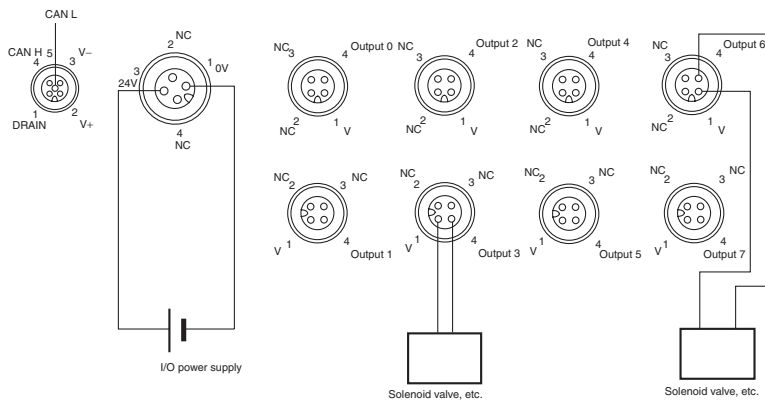

DRT2-OD08CL-1 (PNP)

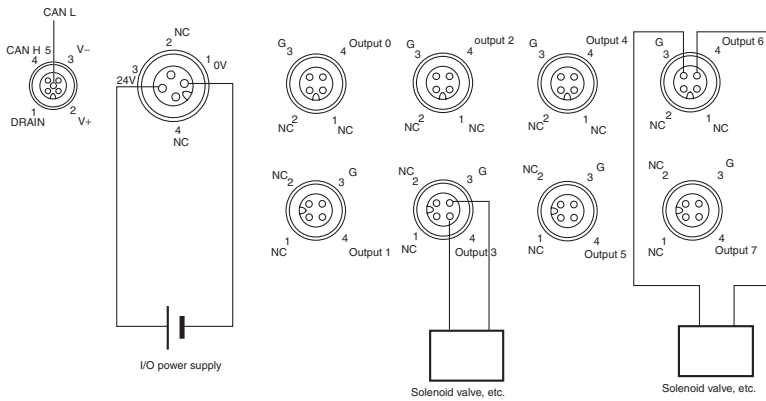

DRT2-HD16CL (NPN)

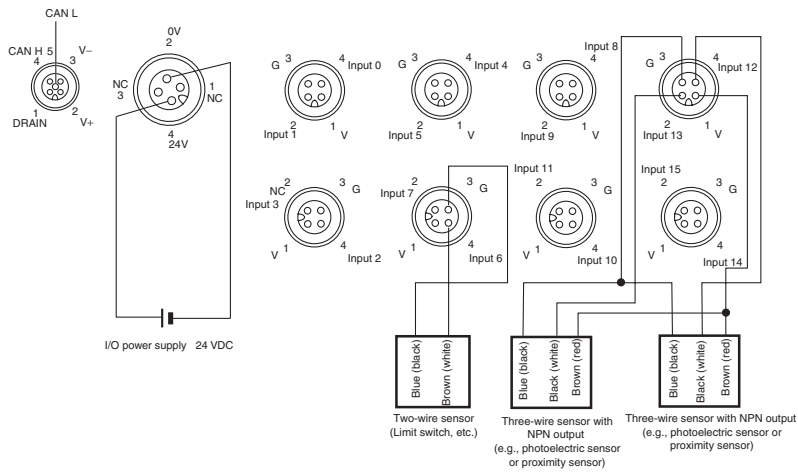

DRT2-HD16CL-1 (PNP)

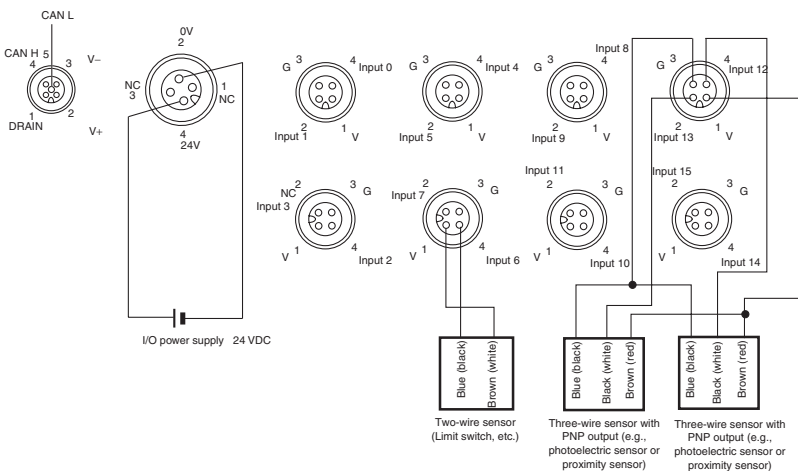

DRT2-WD16CL (NPN)

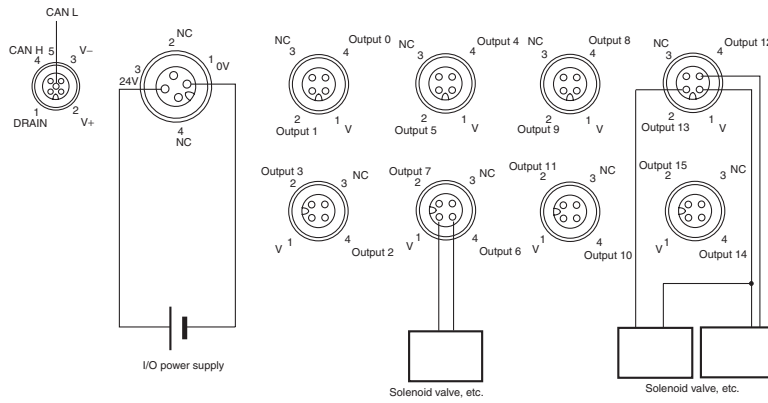

DRT2-WD16CL-1 (PNP)

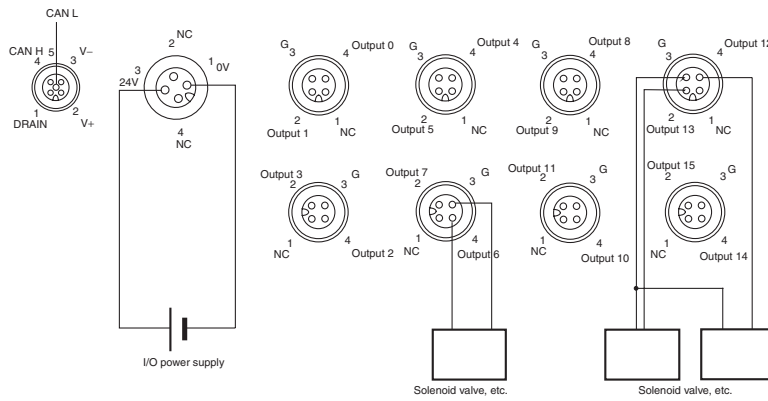

DRT2-MD16CL (NPN)

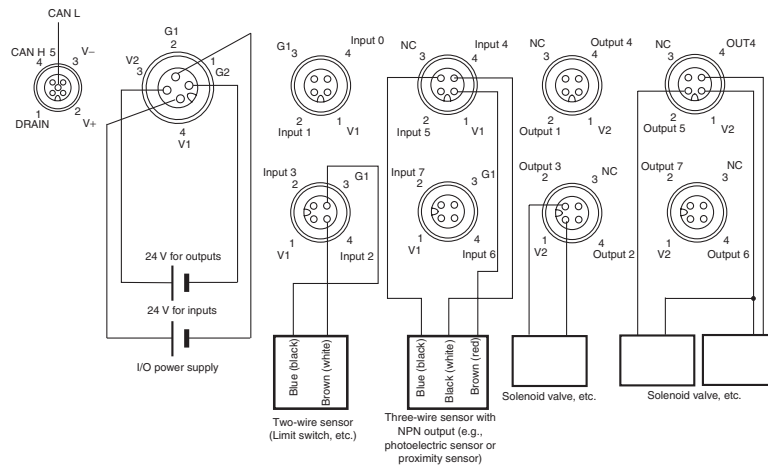

DRT2-MD16CL-1 (PNP)

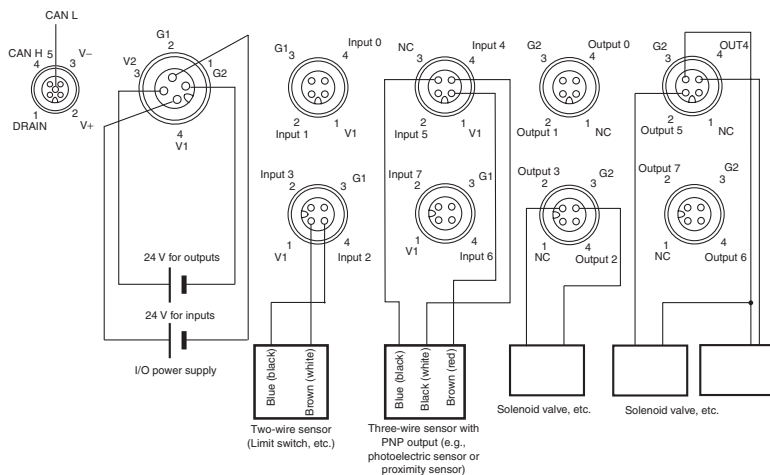

Applicable Cables

■ MIL Connectors with Transistors

● Connector-Terminal Block Conversion Unit and Connecting Cable (16 Points)

Cables with Connectors (1:1)

Model	Applicable cable	Connected Relay Terminal	Remarks
DRT2-ID16ML DRT2-ID16ML-1 DRT2-OD16ML DRT2-OD16ML-1	G79-O□C	XW2D-20G6 XW2B-20G5 XW2B-20G4 XW2C-20G6-IO16	Connector Terminal Block Conversion Unit

● I/O Relay Terminal Connector Cables (16 Points)

Cables with Connectors (1:1)

Model	Applicable cable	Connected Relay Terminal	Remarks
DRT2-ID16ML	G79-I□C	G7TC-ID16 G7TC-IA16	For I/O Relay Terminal inputs
DRT2-ID16ML-1	---	---	(No applicable models)
DRT2-OD16ML	G79-O□C	G7TC-OC16/OC08 G70D-SOC16/VSOC16 G70D-FOM16/VFOM16 G70A-ZOC16-3 G70D-SOC08 G70R-SOC08	For I/O Relay Terminal outputs
DRT2-OD16ML-1	G79-I□C	G7TC-OC16-1	For I/O Relay Terminal outputs
	G79-O□C	G70D-SOC16-1 G70D-FOM16-1 G70A-ZOC16-4	For I/O Relay Terminal outputs

● Cables with Loose Wires with Crimp Terminals



Model	Applicable cable	Remarks
DRT2-ID16ML DRT2-ID16ML-1 DRT2-OD16ML DRT2-OD16ML-1	G79A-Y□C-D1	20-pole connector/ bundled cable (with crimp-style terminals) conversion cable





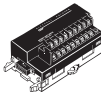

● Cables with Loose Wires

Model	Applicable cable	Remarks
DRT2-ID16ML DRT2-ID16ML-1 DRT2-OD16ML DRT2-OD16ML-1	G79A-A□C-D1	20-pole connector/ bundled cable conversion cable

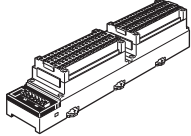
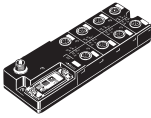
List of Models

●DRT2-series Smart Slaves

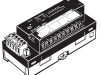
Product name	Shape	Model	Specifications	Approved standards
Remote I/O Basic Terminals with Transistors		DRT2-ID16	16 inputs, NPN (+ common)	UC, CE
		DRT2-ID16-1	16 inputs, PNP (- common)	
		DRT2-OD16	16 outputs, NPN (- common)	
		DRT2-OD16-1	16 outputs, PNP (+ common)	
		DRT2-MD16	8 inputs/8 outputs with NPN, + common for inputs, - common for outputs	
		DRT2-MD16-1	8 inputs/8 outputs with PNP, - common for inputs, + common for outputs	
		DRT2-ID08	8 inputs, NPN (+ common)	
		DRT2-ID08-1	8 inputs, PNP (- common)	
		DRT2-OD08	8 outputs, NPN (- common)	
		DRT2-OD08-1	8 outputs, PNP (+ common)	
Remote I/O Terminal Expansion Units with Transistors		XWT-ID08	8 inputs for terminals with NPN, + common	UC, CE
		XWT-ID08-1	8 inputs for terminals with PNP, - common	
		XWT-OD08	8 outputs for terminals with NPN, - common	
		XWT-OD08-1	8 outputs for terminals with PNP, + common	
		XWT-ID16	16 inputs for terminals with NPN, + common	
		XWT-ID16-1	16 inputs for terminals with PNP, - common	
		XWT-OD16	16 outputs for terminals with NPN, - common	
		XWT-OD16-1	16 outputs for terminals with PNP, + common	
Remote I/O Terminals with 3-tier Terminal Blocks with Transistors		DRT2-ID16TA	16 inputs with NPN, + common	UC, CE
		DRT2-ID16TA-1	16 inputs with PNP, - common	
		DRT2-OD16TA	16 outputs with NPN, - common	
		DRT2-OD16TA-1	16 outputs with PNP, + common	
		DRT2-MD16TA	8 inputs/8 outputs with NPN, + common for inputs, - common for outputs	
DRT2-MD16TA-1	8 inputs/8 outputs with PNP, - common for inputs, + common for outputs			
MIL Connector Terminals with Transistors		DRT2-ID32ML	32 inputs with NPN, + common	UC, CE
		DRT2-ID32ML-1	32 inputs with PNP, - common	
		DRT2-OD32ML	32 outputs with NPN, - common	
		DRT2-OD32ML-1	32 outputs with PNP, + common	
		DRT2-MD32ML	16 inputs/16 outputs with NPN, + common for inputs, - common for outputs	
		DRT2-MD32ML-1	16 inputs/16 outputs with PNP, - common for inputs, + common for outputs	
		DRT2-ID16ML	16 inputs with NPN, + common	
		DRT2-ID16ML-1	16 inputs with PNP, - common	
		DRT2-OD16ML	16 outputs with NPN, - common	
		DRT2-OD16ML-1	16 outputs with PNP, + common	
		DRT2-ID16MLX	16 inputs with NPN, + common, cable with connectors: 10 cm	
		DRT2-ID16MLX-1	16 inputs with PNP, - common, cable with connectors: 10 cm	
		DRT2-OD16MLX	16 outputs with NPN, - common, cable with connectors: 10 cm	
DRT2-OD16MLX-1	16 outputs with PNP, + common, cable with connectors: 10 cm			
Remote I/O Terminals with Relay Outputs		DRT2-ROS16	16 outputs	UR, CE
Board Terminals with MIL Connectors (horizontal mounting)		DRT2-ID32B	32 inputs, NPN (+ common)	U, CE
		DRT2-ID32B-1	32 inputs, PNP (- common)	
		DRT2-OD32B	32 outputs, NPN (- common)	
		DRT2-OD32B-1	32 outputs, PNP (+ common)	
		DRT2-MD32B	16 inputs/16 outputs, NPN (inputs: + common/outputs: - common)	
		DRT2-MD32B-1	16 inputs/16 outputs, PNP (inputs: - common/outputs: + common)	
Board Terminals with MIL Connectors (vertical mounting)		DRT2-ID32BV	32 inputs, NPN (+ common)	U, CE
		DRT2-ID32BV-1	32 inputs, PNP (- common)	
		DRT2-OD32BV	32 outputs, NPN (- common)	
		DRT2-OD32BV-1	32 outputs, PNP (+ common)	
		DRT2-MD32BV	16 inputs/16 outputs, NPN (inputs: + common/outputs: - common)	
		DRT2-MD32BV-1	16 inputs/16 outputs, PNP (inputs: - common/outputs: + common)	

Product name	Shape	Model	Specifications	Approved standards
Screw-less Clamp Terminals with Transistors		DRT2-ID32SLH	32 inputs, NPN (+ common) with detection functions	UC, CE
		DRT2-ID32SLH-1	32 inputs, PNP (- common) with detection functions	
		DRT2-OD32SLH	32 outputs, NPN (- common) with detection functions	
		DRT2-OD32SLH-1	32 outputs, PNP (+ common) with detection functions	
		DRT2-MD32SLH	16 inputs/16 outputs, NPN (inputs: + common/outputs: - common) with detection functions	
		DRT2-MD32SLH-1	16 inputs/16 outputs, PNP (inputs: - common/outputs: + common) with detection functions	
		DRT2-ID32SL	32 inputs, NPN (+ common) without detection functions	
		DRT2-ID32SL-1	32 inputs, PNP (- common) without detection functions	
		DRT2-OD32SL	32 outputs, NPN (- common) without detection function	
		DRT2-OD32SL-1	32 outputs, PNP (+ common) without detection function	
Environment-resistive Terminals with Transistors		DRT2-ID08C	8 inputs, NPN (+ common) with detection functions	UC, CE
		DRT2-ID08C-1	8 inputs, PNP (- common) with detection functions	
		DRT2-OD08C	8 outputs, NPN (- common) with detection functions	
		DRT2-OD08C-1	8 outputs, PNP (+ common) with detection functions	
		DRT2-HD16C	16 inputs, NPN (+ common) with detection functions	
		DRT2-HD16C-1	16 inputs, PNP (- common) with detection functions	
Environment-resistive Terminals with Transistors		DRT2-ID04CL	4 inputs, NPN (+ common) without detection functions	UC, CE
		DRT2-ID04CL-1	4 inputs, PNP (- common) without detection functions	
		DRT2-OD04CL	4 outputs, NPN (- common) without detection functions	
		DRT2-OD04CL-1	4 outputs, PNP (+ common) without detection functions	
		DRT2-ID08CL	8 inputs, NPN (+ common) without detection functions	UC, CE
		DRT2-ID08CL-1	8 inputs, PNP (- common) without detection functions	
		ADRT2-OD08CL	8 outputs, NPN (- common) without detection functions	
		DRT2-OD08CL-1	8 outputs, PNP (+ common) without detection functions	
		DRT2-HD16CL	16 inputs, NPN (+ common) without detection functions	
		DRT2-HD16CL-1	16 inputs, PNP (- common) without detection functions	
		DRT2-WD16CL	16 outputs, NPN (- common) without detection functions	
		DRT2-WD16CL-1	16 outputs, PNP (+ common) without detection functions	
		DRT2-MD16CL	8 inputs/8 outputs, NPN (inputs: + common/outputs: - common) without detection function	
		DRT2-MD16CL-1	8 inputs/8 outputs, PNP (inputs: - common/outputs: + common) without detection function	
e-con Connector Terminals		DRT2-ID16S	16 inputs, NPN (+ common)	UC, CE
		DRT2-ID16S-1	16 inputs, PNP (- common)	
		DRT2-MD16S	8 inputs/8 outputs, NPN (inputs: + common/outputs: - common)	
		DRT2-MD16S-1	8 inputs/8 outputs, PNP (inputs: - common/outputs: + common)	
Analog Input Terminals		DRT2-AD04	4 inputs (resolution: 6,000)	UC, CE
DRT2-AD04H		4 inputs (resolution: 30,000)		
Analog Output Terminals		DRT2-DA02	2 outputs	
Temperature Input Terminals with Thermocouple Inputs		DRT2-TS04T	4 inputs	U, CE
Temperature Input Terminals with Resistance-thermometer Inputs		DRT2-TS04P	4 inputs	

● Intelligent Slaves

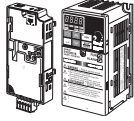
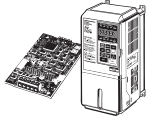
Product name	Shape	Model	Specifications	Approved standards
Modular Temperature Controllers		E5ZN-DRT	DeviceNet Communications Unit for E5ZN	---
		E5ZN-SCT24S	Terminal Unit	
	---	E5ZN-SDL	Setting Display Unit	
Multi-function Compact Inverter		3G3MV-PDRT2	Communications Unit for 3G3MV Inverters	U, CE
High-function General-purpose Inverters		3G3RV-PDRT2	3G3RV/3G3FV DeviceNet Communications Card	U, CE

MEMO

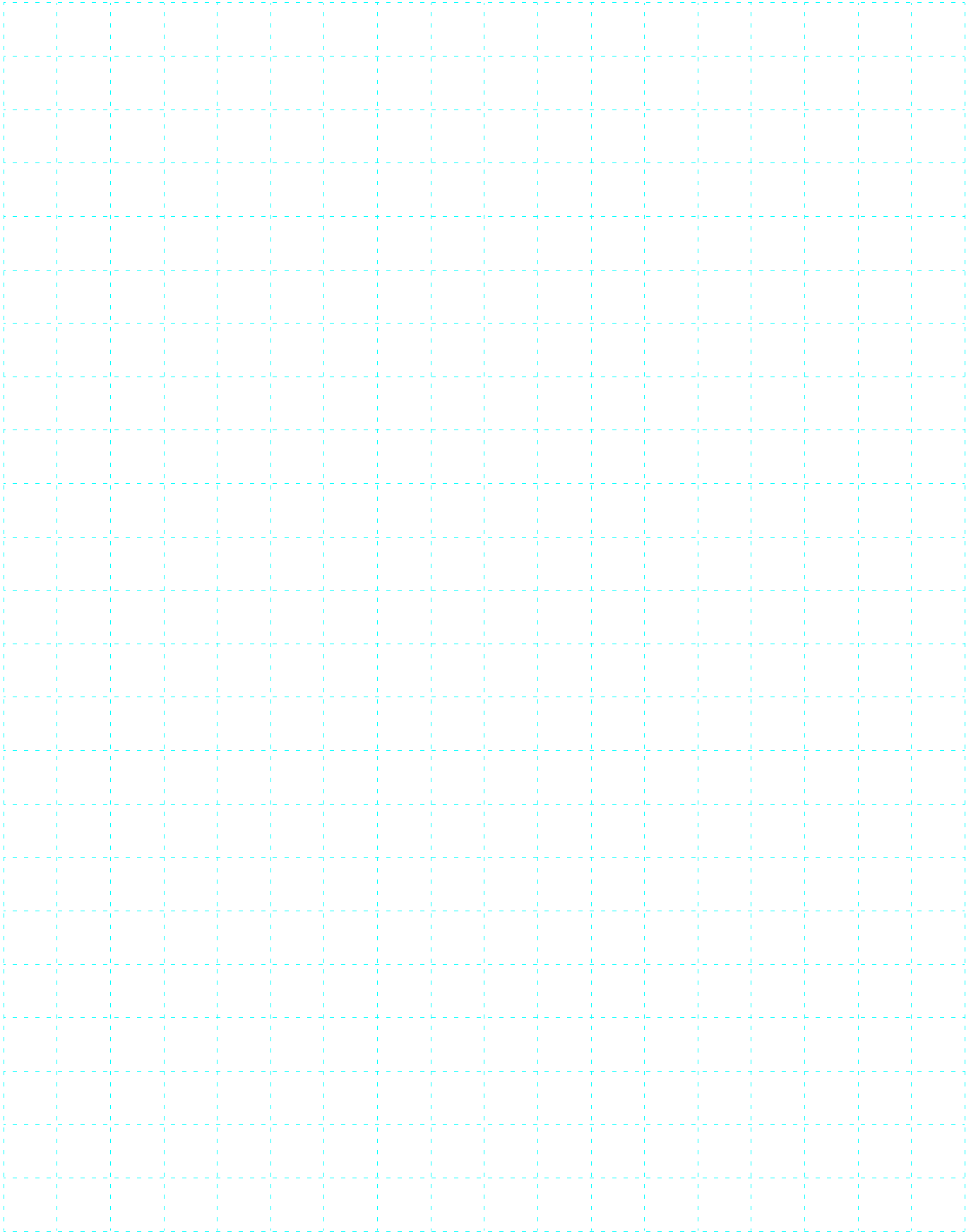

Read and Understand this Catalog

Please read and understand this catalog before purchasing the product. Please consult your OMRON representative if you have any questions or comments.

Warranty and Limitations of Liability

WARRANTY

OMRON's exclusive warranty is that the products are free from defects in materials and workmanship for a period of one year (or other period if specified) from date of sale by OMRON.

OMRON MAKES NO WARRANTY OR REPRESENTATION, EXPRESS OR IMPLIED, REGARDING NON-INFRINGEMENT, MERCHANTABILITY, OR FITNESS FOR PARTICULAR PURPOSE OF THE PRODUCTS. ANY BUYER OR USER ACKNOWLEDGES THAT THE BUYER OR USER ALONE HAS DETERMINED THAT THE PRODUCTS WILL SUITABLY MEET THE REQUIREMENTS OF THEIR INTENDED USE. OMRON DISCLAIMS ALL OTHER WARRANTIES, EXPRESS OR IMPLIED.

LIMITATIONS OF LIABILITY

OMRON SHALL NOT BE RESPONSIBLE FOR SPECIAL, INDIRECT, OR CONSEQUENTIAL DAMAGES, LOSS OF PROFITS OR COMMERCIAL LOSS IN ANY WAY CONNECTED WITH THE PRODUCTS, WHETHER SUCH CLAIM IS BASED ON CONTRACT, WARRANTY, NEGLIGENCE, OR STRICT LIABILITY.

In no event shall the responsibility of OMRON for any act exceed the individual price of the product on which liability is asserted.

IN NO EVENT SHALL OMRON BE RESPONSIBLE FOR WARRANTY, REPAIR, OR OTHER CLAIMS REGARDING THE PRODUCTS UNLESS OMRON'S ANALYSIS CONFIRMS THAT THE PRODUCTS WERE PROPERLY HANDLED, STORED, INSTALLED, AND MAINTAINED AND NOT SUBJECT TO CONTAMINATION, ABUSE, MISUSE, OR INAPPROPRIATE MODIFICATION OR REPAIR.

Application Considerations

SUITABILITY FOR USE

OMRON shall not be responsible for conformity with any standards, codes, or regulations that apply to the combination of the product in the customer's application or use of the product.

Take all necessary steps to determine the suitability of the product for the systems, machines, and equipment with which it will be used.

Know and observe all prohibitions of use applicable to this product.

NEVER USE THE PRODUCT FOR AN APPLICATION INVOLVING SERIOUS RISK TO LIFE OR PROPERTY WITHOUT ENSURING THAT THE SYSTEM AS A WHOLE HAS BEEN DESIGNED TO ADDRESS THE RISKS, AND THAT THE OMRON PRODUCT IS PROPERLY RATED AND INSTALLED FOR THE INTENDED USE WITHIN THE OVERALL EQUIPMENT OR SYSTEM.

PROGRAMMABLE PRODUCTS

OMRON shall not be responsible for the user's programming of a programmable product, or any consequence thereof.

Disclaimers

CHANGE IN SPECIFICATIONS

Product specifications and accessories may be changed at any time based on improvements and other reasons. Consult with your OMRON representative at any time to confirm actual specifications of purchased product.

DIMENSIONS AND WEIGHTS

Dimensions and weights are nominal and are not to be used for manufacturing purposes, even when tolerances are shown.

PERFORMANCE DATA

Performance data given in this catalog is provided as a guide for the user in determining suitability and does not constitute a warranty. It may represent the result of OMRON's test conditions, and the users must correlate it to actual application requirements. Actual performance is subject to the OMRON Warranty and Limitations of Liability.

Note: Do not use this document to operate the Unit.

Printed on 100%
Recycled Paper



OMRON Corporation
Industrial Automation Company
Control Devices Division H.Q.
Shiokoji Horikawa, Shimogyo-ku,
Kyoto, 600-8530 Japan
Tel:(81)75-344-7109
Fax:(81)75-344-7149

Regional Headquarters

OMRON EUROPE B.V.
Wegalaan 67-69, NL-2132 JD Hoofddorp
The Netherlands
Tel:(31)2356-81-300/
Fax:(31)2356-81-388

OMRON ELECTRONICS LLC
1 East Commerce Drive, Schaumburg,
IL 60173 U.S.A.
Tel:(1)847-843-7900/Fax:(1)847-843-8568

OMRON ASIA PACIFIC PTE. LTD.
83 Clemenceau Avenue,
#11-01, UE Square,
Singapore 239920
Tel:(65)6835-3011/Fax:(65)6835-2711

OMRON (CHINA) CO., LTD.
Room 2211, Bank of China Tower,
200 Yin Cheng Zhong Road,
PuDong New Area, Shanghai, 200120 China
Tel:(86)21-5037-2222/Fax:(86)21-5037-2200

Authorized Distributor:

Note: Specifications subject to change without notice.

Cat. No. R110-E1-05
Printed in Japan
1006-0.3M