



Use the Tough E6C2-A (Rated IP64 for Degree of Protection) Combined with a PLC or Cam Positioner for Optimum Control and Ease-of-Use

- Incorporates a sealed bearing, meeting IP64 for durability
- Compact: 50-mm diameter x 38-mm height
- 8 mm-dia. stainless steel shaft is twice as strong as conventional shafts
- Reliable bearing and metal slit plate ensure shock resistance of 1000 m/s²

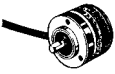

Ordering Information

■ ABSOLUTE ROTARY ENCODERS

Appearance	Connection method	Connecting device	Resolution (p/r)	Part number
	Cable	Programmable Controller	256, 360, 720, 1,024	E6C2-AG5C 256 E6C2-AG5C 360 E6C2-AG5C 720 E6C2-AG5C 1024
	Connector	H8PS Cam Positioner	256	E6C2-AG5C-C 256

Note: The H8PS can be connected to the E6C2-AG5C-C but not to the E6C2-AG5C.

■ ACCESSORIES (ORDER SEPARATELY)

Refer to *Dimensions* section for details

Item	Part number	
Coupling	E69-C08B	
Flange	E69-FCA-03	
	E69-FCA-04	
Extension cable	5 m	E69-DF5
	10 m	E69-DF10
	15 m	E69-DF15
	20 m	E69-DF20

Specifications

■ RATINGS/CHARACTERISTICS

Power supply voltage		12 VDC ^{-10%} to 24 VDC ^{+15%} , ripple (p-p) 5% max.
Current consumption		70 mA max.
Resolution (See Note 1)		256, 360, 720, 1,024 P/R
Output code (absolute)		Gray code
Output configuration		NPN open collector
Output capacity	Applied voltage	30 VDC max.
	I _{sink}	35 mA max.
	Residual voltage	0.4 V max.
Max. response frequency (See Note 2)		20 kHz
Logic		Negative logic output (H=0, L=1)
Rotational direction		Clockwise, as viewed from the face of the shaft
Rise and fall times of output		1 μs max. (cable length: 2m; I _{sink} : 35 mA max.)
Starting torque		100 gf • cm (0.087 in • lbf) max. at room temperature 150 gf • cm (0.13 in • lbf) max. at low temperature
Moment of inertia		15 g • cm ² (1.5 x 10 ⁻⁶ kg • m ²) or 0.005 lb • in ² max.
Shaft loading	Radial	8 kgf (78.4N) or 17.6 lbf
	Thrust	5 kgf (49N) or 11.0 lbf
Maximum permissible rotation		5,000 rpm
Ambient temperature	Operating	-10°C to 70°C (14°F to 158°F) with no icing
	Storage	-25°C to 85°C (-13°F to 185°F) with no icing
Ambient humidity	Operating	35% to 85% (with no condensation)
Insulation resistance		20 MΩ min. (at 100 VDC) between carry parts and case
Dielectric strength		500 VAC, 50/60 Hz for 1 min between carry parts and case
Vibration resistance		Destruction: 10 to 500 Hz, 1.0-mm single amplitude or 150 m/s ² (approx. 15G) for 11 min. 3 times each in X, Y, and Z axes
Shock resistance		Destruction: 1,000 m/s ² (approx. 100G) 3 times each in X, Y, and Z axes
Degree of protection		IEC IP64
Weight		300 g (0.66 lbs) with 2-m cable

Note: 1. A gray code signal with a remainder of 76 is used for a resolution of 360 per rotation and a gray code signal with a remainder of 152 is used for a resolution of 720 per rotation. Therefore, the code signal for a resolution of 360 per rotation uses addresses 76 through 435 and that for a resolution of 720 per rotation uses addresses 152 through 871.

2. The electrical maximum response rotation is determined by using the resolution and maximum response frequency in the following formula.

$$\text{Electrical maximum response rotation (rpm)} = \frac{\text{Maximum response frequency}}{\text{Resolution}} \times 60$$

Therefore, a signal cannot follow electrically if the actual rotation exceeds the maximum response rotation.

Connections

■ DURABLE DESIGN

The E6C2-A incorporates a high-performance LED, custom-made diode array, high-density printed circuit board, and a compact, watertight, seal bearing that withstands heavy loads, thus ensuring high mechanical durability, watertight performance, and compactness. The O-ring applied to the casing and a watertight packing applied to the cable connector enhance the watertight performance of the E6C2-A.

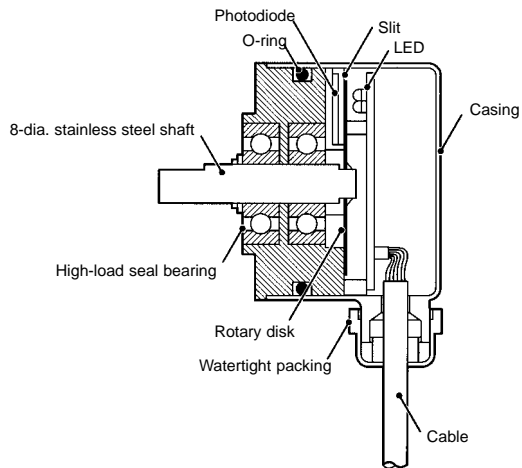

■ SHAFT STRENGTH

The E6C2-A has a stainless steel shaft that is 8 mm in diameter and approximately twice as strong as OMRON's conventional Rotary Encoder shaft. The E6C2-A also has a reliable bearing and metal slit plate, ensuring a shock resistance of 1,000 m/s².

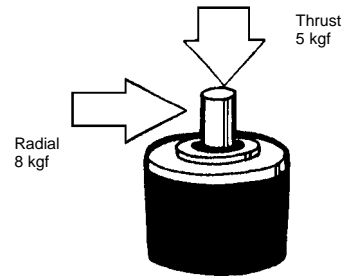

Operation

■ CONNECTIONS

Cable Specifications

Wire color	Output signal		
	E6C2-AG5C		
	8-bit (256)	9-bit (360)	10-bit (720, 1,024)
Light blue	NC	NC	2 ⁹
Pink	NC	2 ⁸	2 ⁸
Purple	2 ⁵	2 ⁵	2 ⁵
Orange	2 ¹	2 ¹	2 ¹
Brown	2 ⁰	2 ⁰	2 ⁰
White	2 ⁷	2 ⁷	2 ⁷
Blue	2 ⁴	2 ⁴	2 ⁴
Yellow	2 ²	2 ²	2 ²
Green	2 ³	2 ³	2 ³
Gray	2 ⁶	2 ⁶	2 ⁶
---	Shield (GND)		
Red	12 to 24 VDC		
Black	0 V (Common)		

■ CONNECTOR SPECIFICATIONS

Pin number	Output signal
	E6C2-AG5C-C
	8-bit (256)
1	NC
2	NC
3	2 ⁵
4	2 ¹
5	2 ⁰
6	2 ⁷
7	2 ⁴
8	2 ²
9	2 ³
10	2 ⁶
11	Shield (GND)
12	12 to 24 VDC
13	0 V (Common)

■ OUTPUT CIRCUIT DIAGRAM

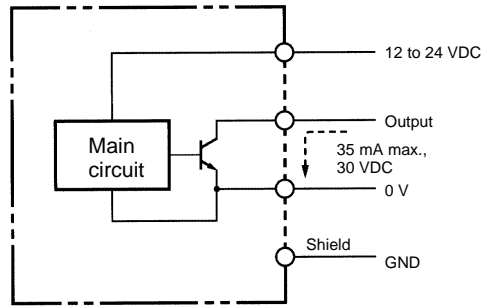

Note: Each output bit uses the same circuit.

■ OUTPUT MODE

Rotating direction: CW, as viewed from the face of the shaft.

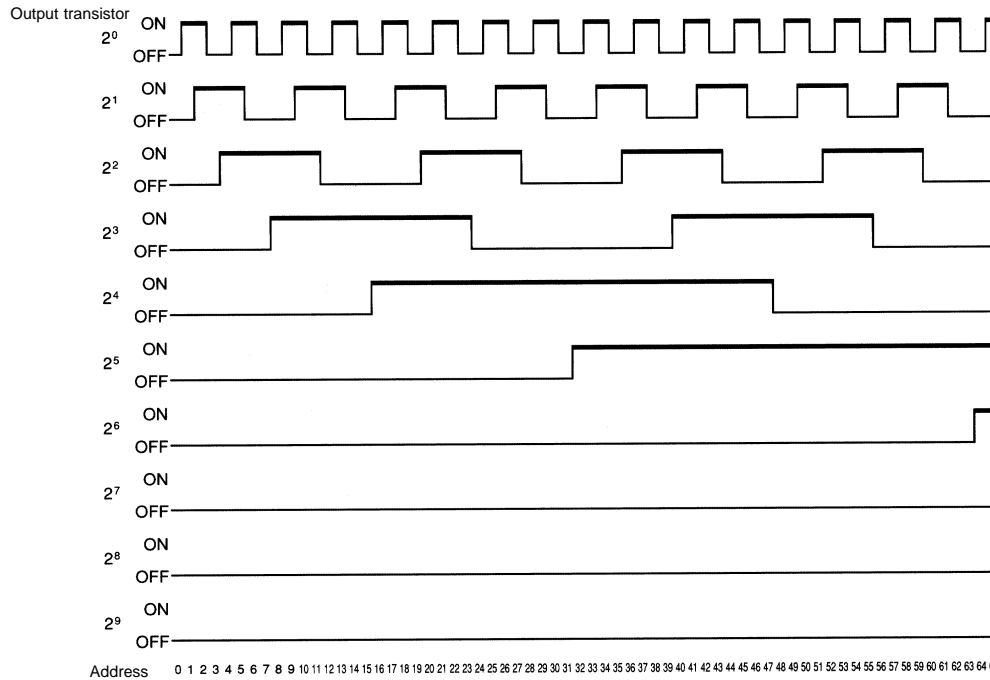

Dimensions

Unit: mm (inch)

■ E6C2-AG5C

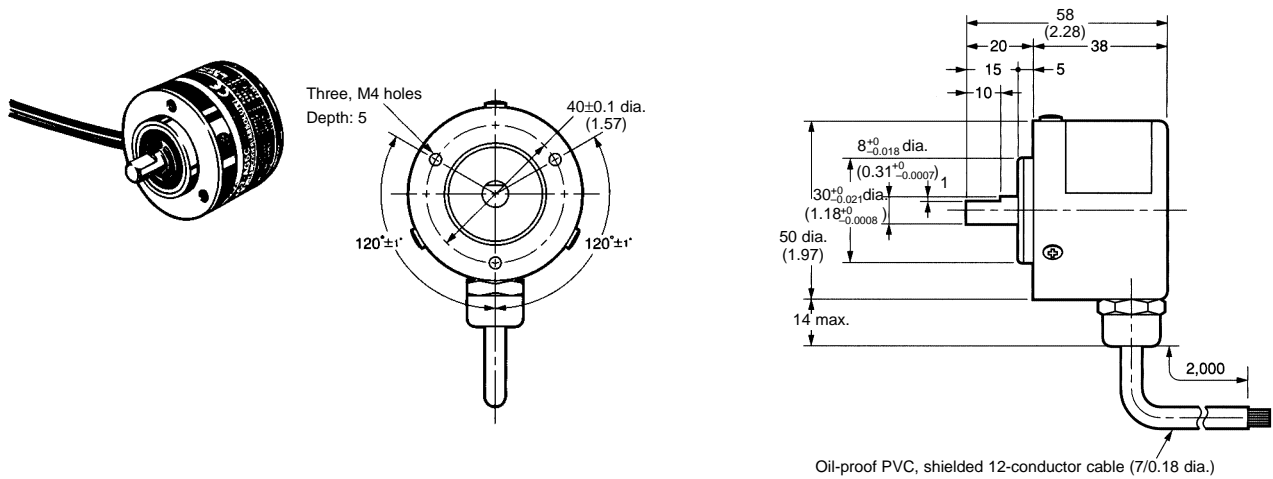

■ E6C2-AG5C-C

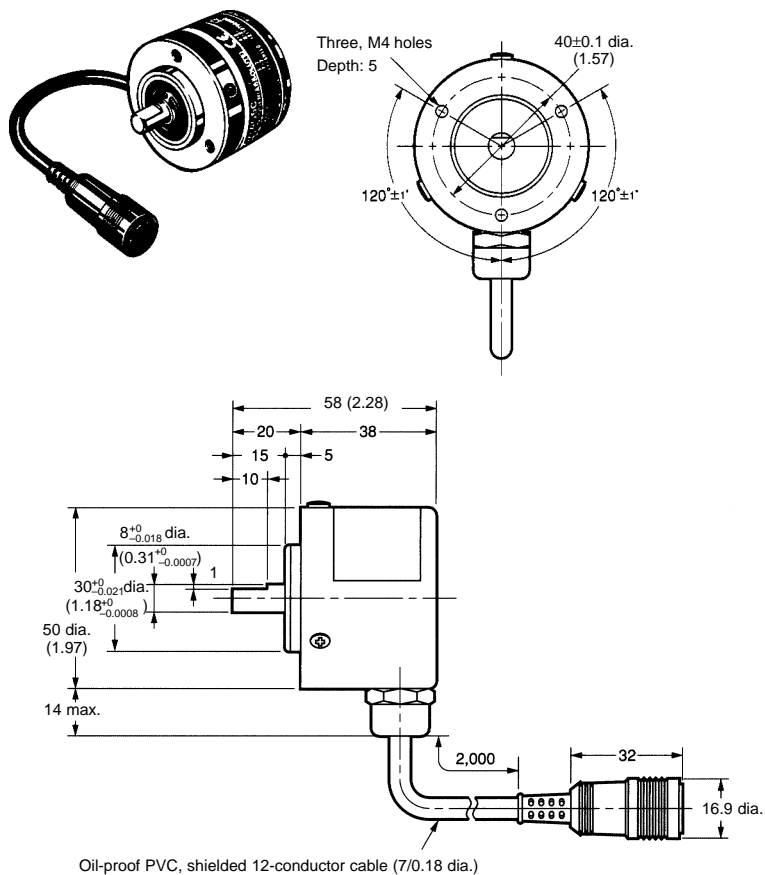

Installation

■ CONNECTING E6C2-AG5C-C TO H8PS CAM POSITIONER

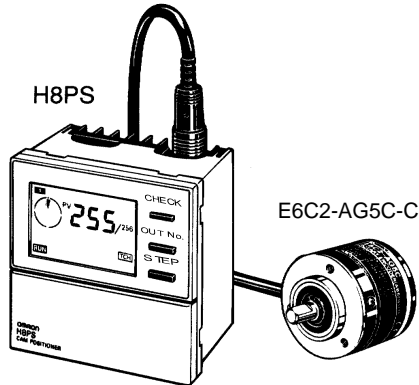

Model	Mounting method	Output configuration
H8PS-8B	Flush	NPN transistor output
H8PS-8BP		PNP transistor output
H8PS-8BF	Surface/Track	NPN transistor output
H8PS-8BFP		PNP transistor output

Specifications

Rated voltage	24 VDC
Cam resolution	1.4° (a resolution of 256 per rotation)
Outputs	<p>Open-collector transistor output NPN: H8PS-8B(F) PNP: H8PS-8B(F)P</p> <p>Cam outputs: 8 lines (Output No. 1 to 8) 30 VDC max., 100 mA max. (residual voltage: 2 V max.)</p> <p>RUN OUT: Turns ON in Run and Test modes, OFF in Program mode in case of error 30 VDC max., 100 mA max. (residual voltage: 2 V max.)</p> <p>TACHOMETER: 60-ppr signal output for rpm meter 30 VDC max., 30 mA max. (residual voltage: 0.5 V max. for NPN models, 2 V max. for PNP models)</p>
Encoder response	330 rpm
Functions	<p>Origin compensation (zero shift) Rotating direction selection Angle display selection Teaching</p>

■ CONNECTING E6C2-AG5C TO PROGRAMMABLE CONTROLLER

Example of Connection to CQM1-CPU44-E High-capacity CPU Unit with Absolute Interface and RS-232C Port

Position data can be directly input as 8, 10, or 12-bit gray code signals from Absolute Encoders to the CQM1-CPU44-E. The position data input is backed up during power failures. Therefore, the origin return operation is not required after the power supply resumes. Furthermore, the origin compensation function of the E6C2-AG5C makes it possible to use any position for the origin.

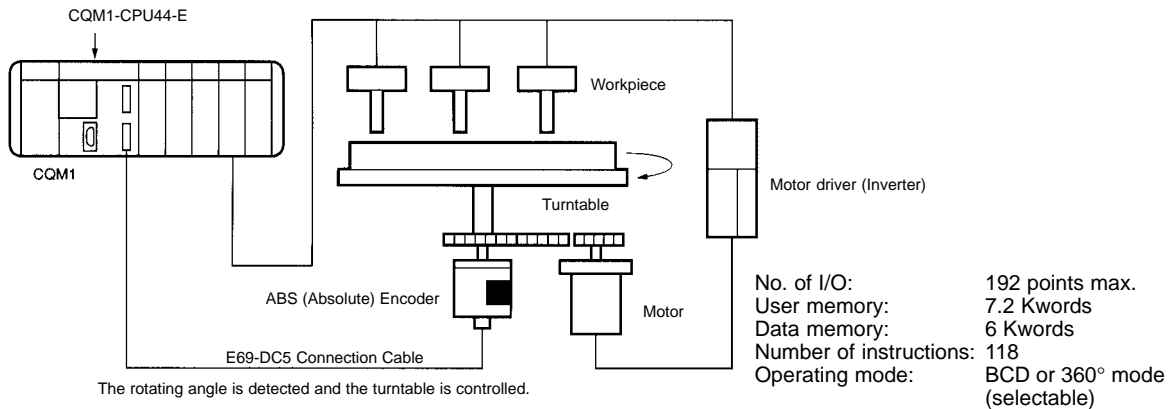

Input Specifications

Input voltage	24 VDC $+10\%$ / -15%
Input impedance	5.4 k Ω
Input current	4 mA (TYP.)
ON voltage	16.8 VDC min.
OFF voltage	3.0 VDC max.
Counting speed	4 kHz max.
Input code	Gray code (8, 10, or 12 bits)

E69-DC5 5M Connection Cable for CQM1-CPU44-E (Order Separately)

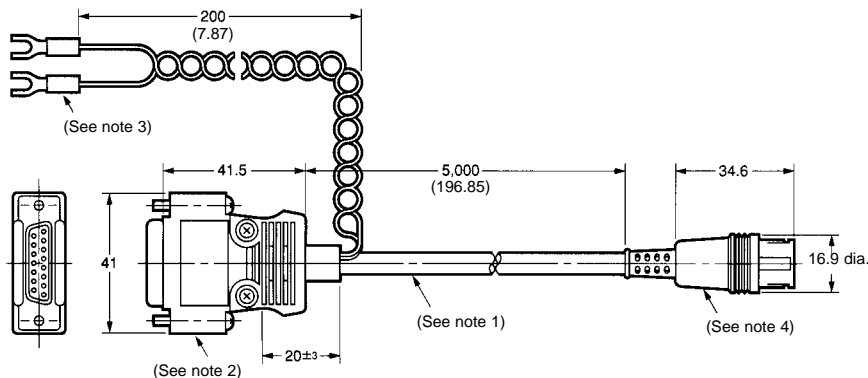

- Note: 1. 6-dia. oil-proof PVC, shielded 12-conductor cable (7/0.18 dia.); standard length: 5 m
2. Connected to CQM1-CPU44-E.
3. 12 to 24 VDC
4. Connected to Encoder.

System Configuration Using a Resolution of 1,024 per Rotation

A combination of the CQM1-CPU4-4E and E6C2-AG5C ensures easy output angle setting for cam control in 360° or BCD mode.

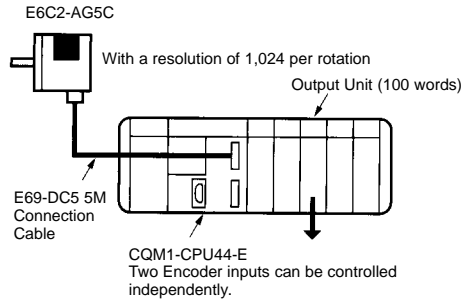

Mode Setting of CQM1-CPU44-E

Set port 1 to BCD mode and 10 bits

DM 6643 0001

Output Timing

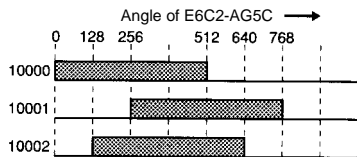

Ladder Program Example

Use the CTBL instruction of the CQM1-CPU44-E to register a maximum of eight comparison tables for output angle setting.

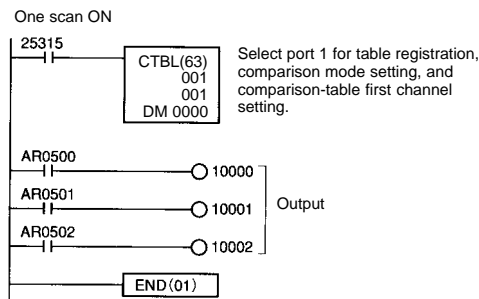

Example of DM Setting for Comparison Table

DM0000	0000	Lower limit 1	} Bit AR 0500
0001	0512	Upper limit 1	
0002	0000	Subroutine number 1	} Bit AR 0501
0003	0256	Lower limit 2	
0004	0768	Upper limit 2	} Bit AR 0502
0005	0000	Subroutine number 2	
0006	0128	Lower limit 3	} Bit AR 0502
0007	0640	Upper limit 3	
0008	0000	Subroutine number 3	} Not used.
0009	0000	Lower limit 4	
0022	0000	Upper limit 8	} Not used.
0023	0000	Subroutine number 8	

Note: An upper or lower limit can be set with integers in BCD mode and 5° increments in 360° mode. Subroutine numbers are set for interrupt processing.

Internal Bits of CQM1-CPU44-E

Range Comparison Result

Each bit of the CQM1-CPU44-E CPU Unit's words AR 05 and AR 06 turns ON only when the comparison range coincides with the angle of E6C2-AG5C.

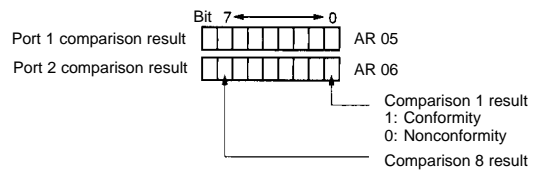

Present Value Read

The gray code signals of the E6C2-AG5C are automatically converted into BCD or 360° code signals and read through the CQM1-CPU44-E CPU Unit's words AR 232 and AR 234. The present value can be used for ladder programs.

Port 1 angle **** Word 232
 Port 2 angle **** Word 234

CONNECTING TO CPM1A USING A RESOLUTION OF 720 PER ROTATION

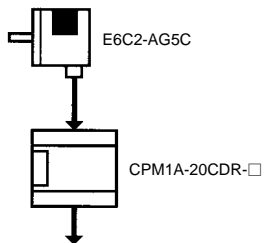

Wiring Between E6C2-AG5C and CPM1A

Output signal from E6C2-AG5C	Input signal to CPM1A
Brown (2 ⁰)	00000
Orange (2 ¹)	00001
Yellow (2 ²)	00002
Green (2 ³)	00003
Blue (2 ⁴)	00004
Purple (2 ⁵)	00005
Gray (2 ⁶)	00006
White (2 ⁷)	00007
Pink (2 ⁸)	00008
Light blue (2 ⁹)	00009

Output Timing



Ladder Program

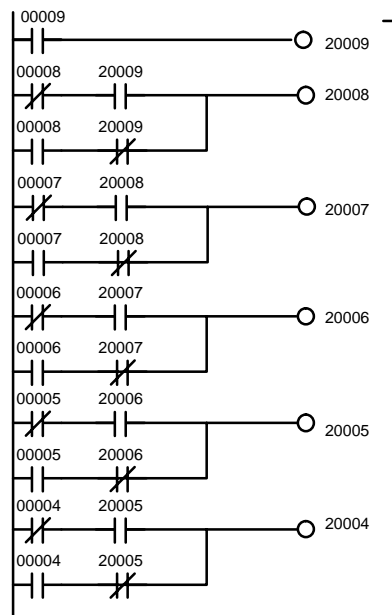

Converts a gray code signal into a BIN code signal (word 200).

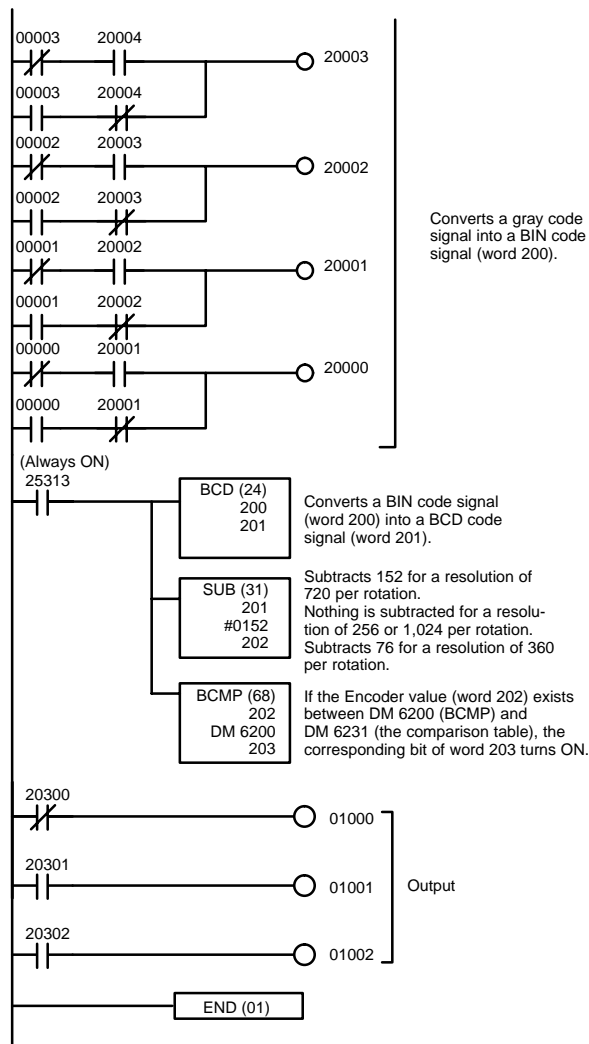

Converts a gray code signal into a BIN code signal (word 200).

Converts a BIN code signal (word 200) into a BCD code signal (word 201).

Subtracts 152 for a resolution of 720 per rotation. Nothing is subtracted for a resolution of 256 or 1,024 per rotation. Subtracts 76 for a resolution of 360 per rotation.

If the Encoder value (word 202) exists between DM 6200 (BCMP) and DM 6231 (the comparison table), the corresponding bit of word 203 turns ON.

Example of DM Setting for Comparison Table

DM6200	0000	Lower limit 1] Bit 20300
6201	0540	Upper limit 1	
6202	0090	Lower limit 2] Bit 20301
6203	0360	Upper limit 2	
6204	0180	Lower limit 3] Bit 20302
6205	0659	Upper limit 3	
6206	0000	Lower limit 4] Not used.
6231	0000	Upper limit 16	

GRAY-TO-BINARY CONVERSION CIRCUIT REFERENCE

Note: This circuit example is for 10-bit signals. For 9-bit signals, input Vin into the XOR of 2⁸, and for 8-bit signals, input Vin into the XOR of 2⁷.

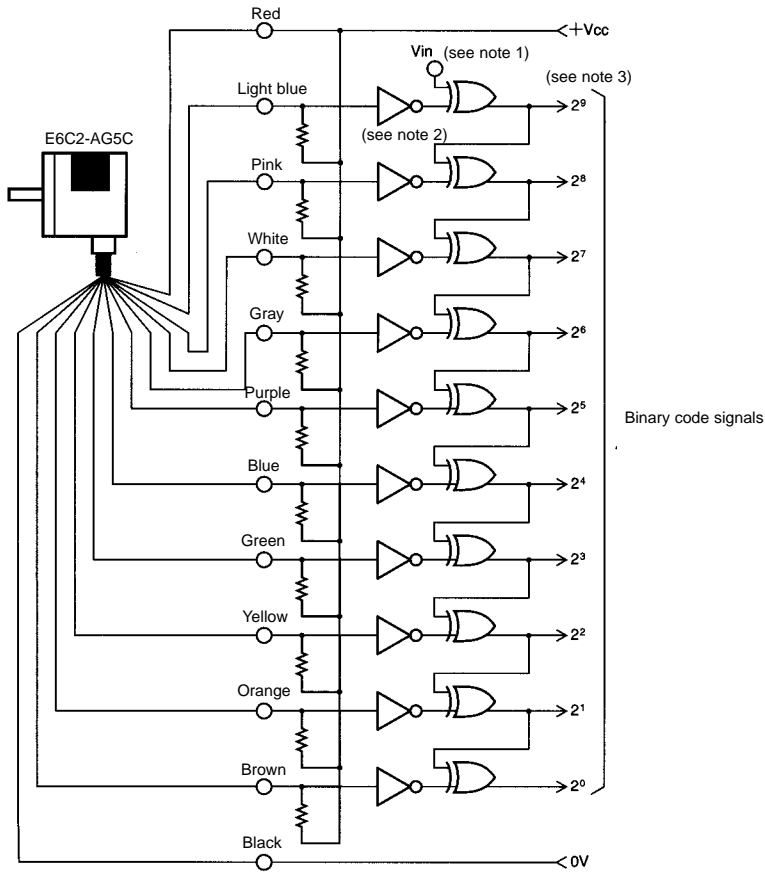

- Note: 1. Signal can be converted into positive-logic binary code signals if 0 V is connected to Vin.
 2. Inverter
 3. Exclusive OR (EOR)

NOTE: DIMENSIONS SHOWN ARE IN MILLIMETERS. To convert millimeters to inches divide by 25.4.

OMRON[®]
OMRON ELECTRONICS, INC.
 One East Commerce Drive
 Schaumburg, IL 60173
1-800-55-OMRON

OMRON CANADA, INC.
 885 Milner Avenue
 Scarborough, Ontario M1B 5V8
416-286-6465