

User Guide
6641-2211

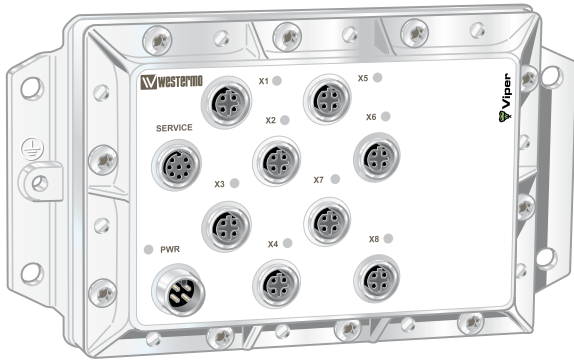

Viper

0 0 8



Unmanaged 8-port Ethernet Switch

www.westermo.com

Legal information

The contents of this document are provided "as is". Except as required by applicable law, no warranties of any kind, either express or implied, including, but not limited to, the implied warranties of merchantability and fitness for a particular purpose, are made in relation to the accuracy and reliability or contents of this document. Westermo reserves the right to revise this document or withdraw it at any time without prior notice.

Under no circumstances shall Westermo be responsible for any loss of data or income or any special, incidental, and consequential or indirect damages howsoever caused.

More information about Westermo can be found at the following Internet address:

<http://www.westermo.com>

Safety



Before installation:

Read this manual completely and gather all information on the unit. Make sure that you understand it fully. Check that your application does not exceed the safe operating specifications for this unit.

This unit should only be installed by qualified personnel.

This unit should be built-in to an apparatus cabinet, or similar, where access is restricted to service personnel only.

The power supply wiring must be sufficiently fused (e.g. Littlefuse 0461 1.25), and if necessary it must be possible to disconnect manually from the power supply. If fault contact is used, make sure that fault contact wiring is sufficiently fused.

This unit uses convection cooling. To avoid obstructing the airflow around the unit, follow the spacing recommendations (see Cooling section).



Before mounting, using or removing this unit:

Prevent access to hazardous voltage by disconnecting the unit from power supply. Warning! Do not open connected unit. Hazardous voltage may occur within this unit when connected to power supply.

Care recommendations

Follow the care recommendations below to maintain full operation of unit and to fulfil the warranty obligations.

This unit must not be operating with removed covers or lids.

Do not attempt to disassemble the unit. There are no user serviceable parts inside.

Do not drop, knock or shake the unit, rough handling above the specification may cause damage to internal circuit boards.

Do not use harsh chemicals, cleaning solvents or strong detergents to clean the unit.

Do not paint the unit. Paint can clog the unit and prevent proper operation.

Do not expose the unit to any kind of liquids (rain, beverages, etc). The unit is not waterproof. Keep the unit within the specified humidity levels.

Do not use or store the unit in dusty, dirty areas, connectors as well as other mechanical part may be damaged.

If the unit is not working properly, contact the place of purchase, nearest Westermo distributor office or Westermo Tech support.

Do not cover or bring mechanical force to the ventilation membrane on the back of the unit.

Maintenance

No maintenance is required, as long as the unit is used as intended within the specified conditions.

Agency approvals and standards compliance

Type	Approval / Compliance
EMC	EN 61000-6-1, Immunity residential environments
	EN 61000-6-2, Immunity industrial environments
	EN 55024, Immunity IT equipment
	EN55022, Emission IT equipment
	EN 61000-6-3, Emission residential environments
	EN 61000-6-4, Emission industrial environments
	EN 50155 Railway applications - Electronic equipment used on rolling stock
	EN 50121-3-2, Railway applications - EMC: Rolling stock – Apparatus
	FCC part 15 Class B
	EN 50121-4, Railway signalling and telecommunications apparatus
	IEC 62236-4, Railway signalling and telecommunications apparatus
Safety	EN 60950-1, IT equipment

FCC Part 15.105 Notice:

This equipment has been tested and found to comply with the limits for a Class B digital device, pursuant to Part 15 of the FCC Rules. These limits are designed to provide reasonable protection against harmful interference in a residential installation. This equipment generates, uses and can radiate radio frequency energy and, if not installed and used in accordance with the instructions, may cause harmful interference to radio communications. However, there is no guarantee that interference will not occur in a particular installation. If this equipment does cause harmful interference to radio or television reception, which can be determined by turning the equipment off and on, the user is encouraged to try to correct the interference by one or more of the following measures:

- ⌘ Reorient or relocate the receiving antenna
- ⌘ Increase the separation between the equipment and receiver
- ⌘ Connect the equipment into an outlet on a circuit different from that to which the receiver is connected
- ⌘ Consult the dealer or an experienced radio/TV technician for help.

Declaration of Conformity



Westermo Teleindustri AB

Declaration of conformity

The manufacturer Westermo Teleindustri AB
SE-640 40 Stora Sundby, Sweden

Type of product	Model	Art no
Ethernet switch	Viper switch	3641-0360, 3641-0350, 3641-0340

is in conformity with the following EC directive(s).

No	Short name
2004/108/EC	Electromagnetic Compatibility (EMC)
2006/95/EC	Low Voltage Directive - LVD

References of standards applied for this EC declaration of conformity.

No	Title	Issue
EN 55022	Information technology equipment – Radio disturbance characteristics - Limits and methods of measurement	2006 +A1:2007
EN 55024	Information technology equipment - Immunity characteristics - Limits and methods of measurement	1998 +A1:2001 +A2:2003
EN 61000-6-1	Immunity for residential, commercial and light-industrial environments	2007
EN 61000-6-2	Immunity for industrial environments	2005
EN 61000-6-3	Emission standard for residential, commercial and light-industrial environments	2007
EN 61000-6-4	Emission standard for industrial environments	2007
EN 50121-3-2	Railway applications - Electromagnetic compatibility	2006
EN 50121-4	Railway applications - Electromagnetic compatibility - Part 4: Emission and immunity of the signaling and telecommunications apparatus	2006
EN 60950-1*	Safety of information technology equipment	2006

The last two digits of the year in which the CE marking was affixed: 09

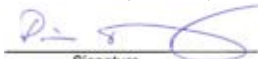
Signature

Pierre Öberg
Technical Manager
28th October 2009

* Note: Manual and safety instructions are only in English

Postaddress/Postal address	Tel.	Telefax	Postgiro	Bankgiro	Org.nr/ Corp. identity number	Registered office
S-640 40 Stora Sundby Sweden	016-428000 Int+46 16428000	016-428001 Int+46 16428001	52 72 79-4	5671-5550	556361-2604	Eskilstuna

Type tests and environmental conditions

Phenomena	Test	Description	Test levels
ESD	EN 61000-4-2	Enclosure contact	± 6 kV (crit A)
		Enclosure air	± 8 kV (crit A)
RF field AM modulated	IEC 61000-4-3	Enclosure	20 V/m 80% AM (1 kHz), 80 – 2500 MHz (crit A)
Fast transient	EN 61000-4-4	Ethernet ports	± 2 kV (crit A)
		Power port	± 2 kV (crit A)
		Earth port	± 2 kV (crit A)
Surge	EN 61000-4-5	Fault port	± 2 kV line to earth (crit A)
		Ethernet ports	± 2 kV line to earth (crit A)
		Power port	± 2 kV line to earth, ± 2 kV line to line (crit A)
RF conducted	EN 61000-4-6	Ethernet ports	10 V 80% AM (1 kHz), 0.15 – 80 MHz (crit A)
		Power port	10 V 80% AM (1 kHz), 0.15 – 80 MHz (crit A)
Power frequency magnetic field	EN 61000-4-8	Enclosure	1000 A/m 50 Hz 300 A/m 16.7 Hz, 60 Hz, DC (crit A)
Pulse magnetic field	EN 61000-4-9	Enclosure	300 A/m (crit A)
Voltage dips and interruption	EN 50155	DC power ports	10 ms, interruption (crit A) 100 ms +/- 40 % above/below rated voltage (crit A)
Radiated emission	EN 55022	Enclosure	Class B
	FCC part 15		Class B
Conducted emission	EN 55022	DC power port & Ethernet ports	Class B
	FCC part 15	DC power port	Class B
Dielectric strength	EN 50155	Ethernet ports to other isolated ports	707 VDC 1 min
		Power & Fault port to other isolated ports	2121 VDC 1 min
Temperature		Operating	-40 to +70°C
		Storage & Transport	-40 to +70°C
Humidity		Operating	5 to 95% relative humidity
		Storage & Transport	5 to 95% relative humidity
Altitude		Operating	2000 m / 70 kPa
Reliability prediction (MTBF)	MIL-C217F2	Operating	Ground Benign: 150 years @ 20 °C 147 years @ 40 °C 135 years @ 60 °C Ground Mobile: 9,87 years @ 20 °C 9,85 years @ 40 °C 9,79 years @ 60 °C Ground Fix: 28,54 years @ 20 °C 28,43 years @ 40 °C 27,95 years @ 60 °C
Service life		Operating	10 year
Vibration, random simulated long life	IEC 60068-2-64, Cat. 1 class B (EN 61373)	Not Operating	Vertical: 7.9 m/s ² Transverse: 7.9 m/s ² Longitudinal: 7.9 m/s ² 3 x 5 h
Vibration, random functional	IEC 60068-2-64, Cat. 1 class B (EN 61373)	Operating	Vertical: 1.0 m/s ² Transverse: 1.0 m/s ² Longitudinal: 1.0 m/s ² 3 x 10 min

Phenomena	Test	Description	Test levels
Shock, half sine pulses	IEC 60068-2-27, Cat. 1 class B (EN 61373)	Operating	Vertical: 50 m/s ² Transverse: 50 m/s ² Longitudinal: 50 m/s ² 30 ms, 3 x 6 shocks
Shock, sawtooth	IEC 60068-2-27, Cat. 1 class B (IEEE1478-2001)	Operating	Vertical: 100 m/s ² Transverse: 100 m/s ² Longitudinal: 100 m/s ² 11 ms, 3 x 6 shocks
Enclosure	UL 94	Nickel coated zinc	Flammability class V-1
Dimension W x H x D			175 x 100 x 53,4 mm
Weight			1 kg
Degree of protection	IEC 529	Enclosure	IP 65 when all ports are protected/ connected else IP 40
Cooling			Convection
Mounting			DIN Rail or wall mounted

Description

Functional description

Viper 008 is a unmanaged switch developed for rail and industrial applications. To meet the environmental requirements from rail and harsh industrial applications the switch has rugged M12 Ethernet connectors and full metal housing. The IP65 sealed metal case make it robust and allows for the surrounding air temperature to be between -40 to $+70^{\circ}\text{C}$. There are no sensitive or fragile components, hardening the product against shock and vibration making these units suitable for rolling stock usage. The power supply operates over a wide input range from 24 to 110 VDC.

Interface specifications

Power and fault relay port PWR	
Rated voltage	24 to 110 VDC
Operating voltage	24 to 110 VDC \pm 40%
Rated current	30 mA @ 110 VDC 90 mA @ 24 VDC
Rated frequency	DC
Inrush current, I ² t	Max 0.02 A ² s @ 24 – 110 VDC
Polarity	Reverse polarity protected
Redundant power input	No
Isolation to	Connections X1 – X8 and to ground, 1500 VAC. Fault relay belongs to the same isolation group as the power supply lines (fault relay signals are also contained within PWR).
Connection	4 pin male M12 connector with A-code
Connector size	M12, recommended cable area 0.5 mm ² recommended (minimum 0.25 mm ²), cable dimensions depend on choice of M12 connector
Shielded cable	Not required, twisted pair is recommended
Fault relay resistance	< 10 Ω
Operating voltage	Up to 110 VDC

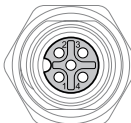
 M12 A-Coded Power Connector	Position	Direction	Description
	1	U+	Positive supply voltage
	2	Out	Alarm relay (status) +
	3	0V	Negative supply voltage
	4	Out	Alarm relay (status) –
	Housing	Shield	Chassis of product (ground)

Fault Contact

The Viper switch is equipped with a potential free normally closed fault contact. The fault contact is a solid state component (relay) that requires power to work and it is transient protected. Additionally, the fault contact is opened when any of the following conditions is met:

- No voltage on the power supply pin, a voltage level outside the legal voltage range or current limitation on the voltage source is applied on the power input.

Description of how connection to the fault contact could be done is shown below. The relay is closed when the unit is OK and open at failure. The relay is of semiconductor type (no moving parts). It is specified for max current 250 mA continuous, 500 mA peak (10 ms), operational voltage up to 110 V, protected by a 150 VDC-varistor, ON-resistance less than 10 Ohm, and leakage current max 1 μ A.

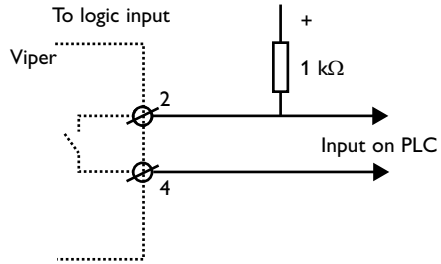
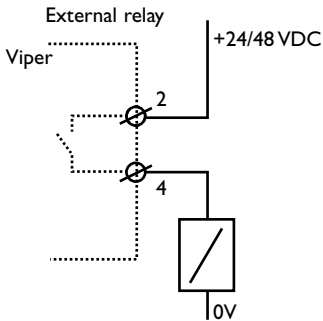

Service port

The Service Port should not be used by non other than the Westermo Technical Support team. Do not connect any device or cable to the Service Port.

Ethernet TX port X1 to X8	
Electrical specification	IEEE std 802.3. 2005 Edition
Data rate	10 Mbit/s or 100 Mbit/s
Duplex	Full or half
Circuit type	TNV-1
Transmission range	100 m
Isolation to	Other Ethernet ports, 500 VAC PWR, 1500 VAC
Galvanic connection to	None, except for shielded contact to housing
Connection	4-pole M12 female with D-code
Shielded cable	Not required, twisted pair is recommended
Conductive housing	Nickel plated zinc, metal housings of X1-X8 also connected to the housing
Number of ports	8 Ethernet (X1-X8)

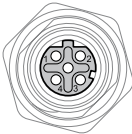
	Position	Direction	Description
	1	Out	Transmit Data +
	2	In	Receive Data +
	3	Out	Transmit Data –
	4	In	Receive Data –
Housing	Shield	Chassis of product (ground)	

Location of Interface ports, LED's

LED indicators

LED	Status	Description
PWR	GREEN	Unit indicates no fault
	RED	Unit indicated fault
X1 to X8	OFF	No Link
	GREEN	Link is up
	GREEN FLASH	Data is transmitted

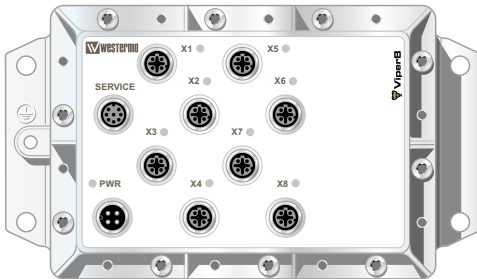

Mounting, DIN-rail

This unit can be mounted on 35 mm DIN-rail, which is horizontally mounted inside an apparatus cabinet or similar. Snap on mounting, see figure.

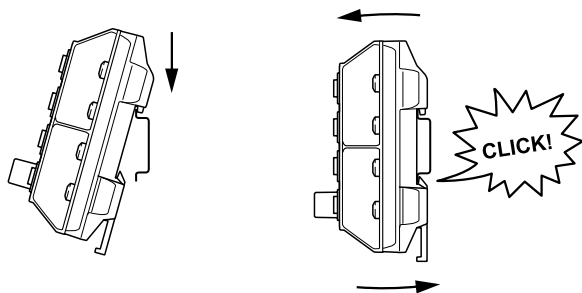

Removal

Press down the support at the back of the unit using a screwdriver. See figure.

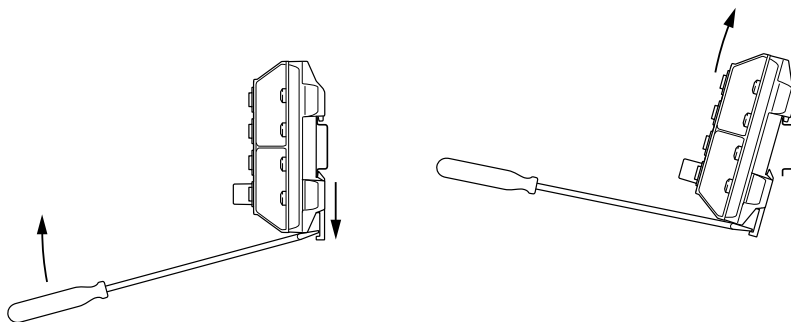

Wall mounting

There are four 6 mm bore holes intended for mounting the unit. The unit can be mounted vertical or horizontal. Use four M6 screws with 12 mm washer on a flat and stable surface.

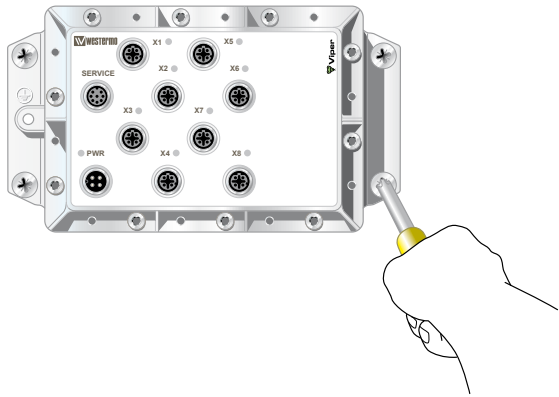

Removal

Disconnect all cables and unscrew the unit from the wall.

Cooling

This unit uses convection cooling. Avoid obstructing the airflow around the unit. Spacing is recommended for the use of unit in full operating temperature range and service life.

Dimensions

Measurements are stated in millimeters.

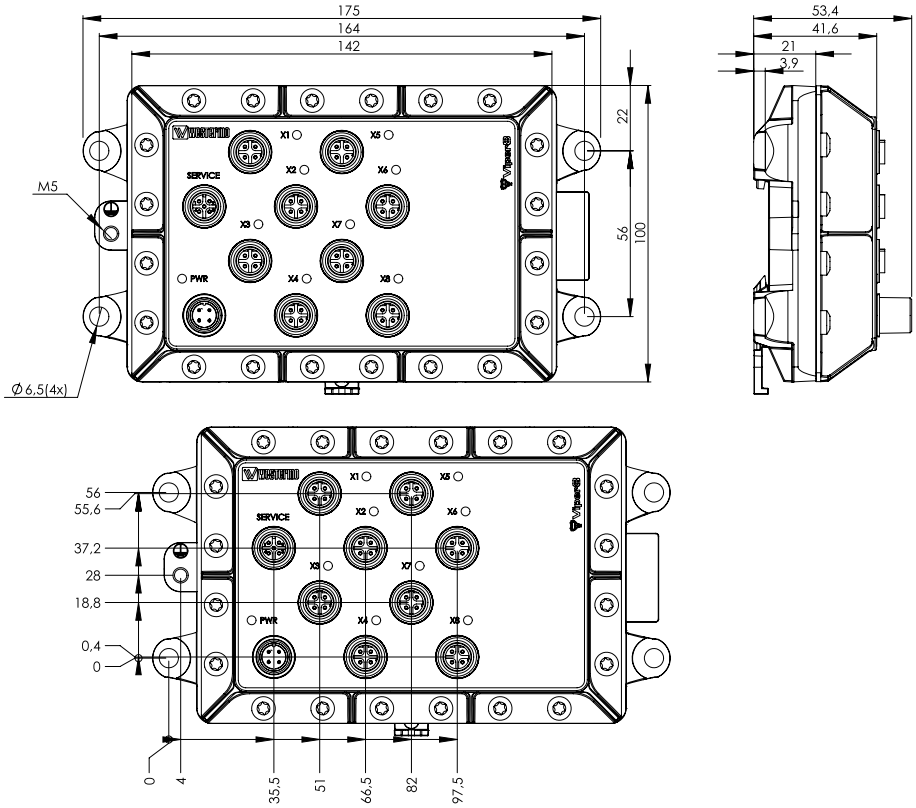



Westermo Teleindustri AB • SE-640 40 Stora Sundby, Sweden
Phone +46 16 42 80 00 Fax +46 16 42 80 01
E-mail: info@westermo.se
Westermo Web site: www.westermo.com

Subsidiaries

Westermo Data Communications AB
Svalgängen 1
SE-724 81 Västerås
Phone: +46 (0)21 548 08 00 • Fax: +46 (0)21 35 18 50
E-Mail: info.sverige@westermo.se

Westermo Data Communications Ltd
Talisman Business Centre • Duncan Road
Park Gate, Southampton • SO31 7GA
Phone: +44(0)1489 580-585 • Fax: +44(0)1489 580586
E-Mail: sales@westermo.co.uk

Westermo Data Communications GmbH
Goethestraße 67, 68753 Waghäusel
Tel.: +49(0)7254-95400-0 • Fax: +49(0)7254-95400-9
E-Mail: info@westermo.de

Westermo Data Communications S.A.R.L.
9 Chemin de Chilly 91160 CHAMPLAN
Tél : +33 1 69 10 21 00 • Fax : +33 1 69 10 21 01
E-mail : infos@westermo.fr

Westermo Data Communications Pte Ltd
2 Soon Wing Road #08-05
Soon Wing Industrial Building
Singapore 347893
Phone +65 6743 9801 • Fax +65 6745 0670
sales@westermo.com.sg

Westermo Teleindustri AB have distributors in several countries, contact us for further information.

AUDIN - 8, avenue de la malle - 51370 Saint Brice Courcelles
Tel : 03.26.04.20.21 - Fax : 03.26.04.28.20 - Web : <http://www.audin.fr> - Email : info@audin.fr