

USER'S MANUAL

DeviceNet Communications Unit

MODEL 3G3MV-PDRT1-SINV1
(For SYSDRIVE 3G3MV Multi-function Compact Inverters)

OMRON

OMRON Corporation
FA Systems Division H.Q.
66 Matsumoto
Mishima-city, Shizuoka 411-8511
Japan
Tel: (81)559-77-9181/Fax: (81)559-77-9045

Authorized Distributor:

Thank you for choosing a 3G3MV Multi-function Compact Inverter and DeviceNet Communications Unit. This manual describes the specifications and operating methods of the DeviceNet Communications Unit used for exchanging data between an Inverter and a Programmable Controller. Specifically, it describes the operation methods, communications methods, and data setting methods of the 3G3MV-PDRT1-SINV1 DeviceNet Communications Unit. Proper use and handling of the product will help ensure proper product performance, will lengthen product life, and may prevent possible accidents.

Please read this manual thoroughly and handle and operate the product with care. For details about the 3G3MV Inverter and DeviceNet communications system, refer to the following manuals.

SYSDRIVE 3G3MV User's Manual (I527)

CS/CJ-series DeviceNet Unit Operation Manual (W380)

DeviceNet Operation Manual (W267)

NOTICE

1. This manual describes the functions of the product and relations with other products. You should assume that anything not described in this manual is not possible.
2. The name "SYSMAC" in this manual refers to the SYSMAC CS/CJ-series, C200HX/HG/HE, and CV-series Programmable Controllers that can be connected to a DeviceNet System. (C200HS Programmable Controllers support only the remote I/O function.)
3. Although care has been given in documenting the product, please contact your OMRON representative if you have any suggestions on improving this manual.
4. The product contains potentially dangerous parts under the cover. Do not attempt to open the cover under any circumstances. Doing so may result in injury or death and may damage the product. Never attempt to repair or disassemble the product.
5. We recommend that you add the following precautions to any instruction manuals you prepare for the system into which the product is being installed.
 - Precautions on the dangers of high-voltage equipment.
 - Precautions on touching the terminals of the product even after power has been turned off. (These terminals are live even with the power turned off.)
6. Inverter and Option Unit wiring and Digital Operator operations must be performed by somebody with a specialist knowledge of electrical systems.
7. The individual life expectancies of the Inverter's internal components must be considered. Perform maintenance, such as Unit replacement, appropriate for the operating conditions.
8. Specifications and functions may be changed without notice in order to improve product performance.

Items to Check Before Unpacking

Check the following items before removing the product from the package:

- Has the correct product been delivered (i.e., the correct model number and specifications)?
- Has the product been damaged in shipping?
- Are any screws or bolts loose?
- Have all accessories been delivered together with or attached to the product?

Notice:

OMRON products are manufactured for use according to proper procedures by a qualified operator and only for the purposes described in this manual.

The following conventions are used to indicate and classify precautions in this manual. Always heed the information provided with them. Failure to heed precautions can result in injury to people or damage to property.

 **DANGER** Indicates an imminently hazardous situation which, if not avoided, will result in death or serious injury.

 **WARNING** Indicates a potentially hazardous situation which, if not avoided, could result in death or serious injury.

 **Caution** Indicates a potentially hazardous situation which, if not avoided, may result in minor or moderate injury, or property damage.

OMRON Product References

All OMRON products are capitalized in this manual. The word “Unit” is also capitalized when it refers to an OMRON product, regardless of whether or not it appears in the proper name of the product.

The abbreviation “Ch,” which appears in some displays and on some OMRON products, often means “word” and is abbreviated “Wd” in documentation in this sense.

The abbreviation “PC” means Programmable Controller and is not used as an abbreviation for anything else.

Visual Aids

The following headings appear in the left column of the manual to help you locate different types of information.

Note Indicates information of particular interest for efficient and convenient operation of the product.

© OMRON, 1999

All rights reserved. No part of this publication may be reproduced, stored in a retrieval system, or transmitted, in any form, or by any means, mechanical, electronic, photocopying, recording, or otherwise, without the prior written permission of OMRON.

No patent liability is assumed with respect to the use of the information contained herein. Moreover, because OMRON is constantly striving to improve its high-quality products, the information contained in this manual is subject to change without notice. Every precaution has been taken in the preparation of this manual. Nevertheless, OMRON assumes no responsibility for errors or omissions. Neither is any liability assumed for damages resulting from the use of the information contained in this publication.

OMRON

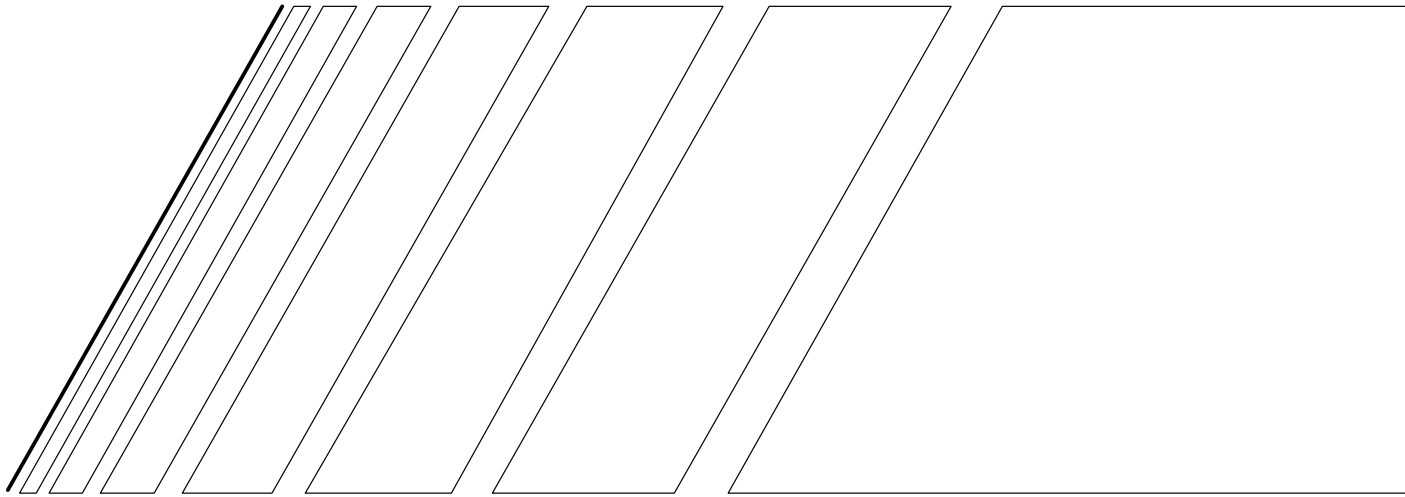

USER'S MANUAL

DeviceNet Communications Unit

MODEL 3G3MV-PDRT1-SINV1
(For SYSDRIVE 3G3MV Multi-function Compact Inverters)

■ General Precautions

The user must operate the product according to the performance specifications described in the operation manuals.

Before using the product under conditions which are not described in the manual or applying the product to nuclear control systems, railroad systems, aviation systems, vehicles, combustion systems, medical equipment, amusement machines, safety equipment, and other systems, machines, and equipment that may have a serious influence on lives and property if used improperly, consult your OMRON representative.

Make sure that the ratings and performance characteristics of the product are sufficient for the systems, machines, and equipment, and be sure to provide the systems, machines, and equipment with double safety mechanisms.

■ Transportation, Installation, Wiring, and Maintenance Precautions

 **WARNING** Do not touch the conductive parts such as internal PCBs or terminal blocks while power is being supplied. Doing so may result in electrical shock.

 **WARNING** Turn ON the input power supply only after mounting the front cover, terminal covers, bottom cover, Operator, and optional items. Leave them mounted in place while power is being supplied. Not doing so may result in electrical shock, malfunction, or damage to the product.

 **WARNING** Wiring, maintenance, or inspection must be performed by authorized personnel. Not doing so may result in electrical shock or fire.

 **WARNING** Wiring, maintenance, or inspection must be performed after turning OFF the power supply, confirming that the CHARGE indicator (or status indicators) is OFF, and after waiting for the time specified on the Inverter front cover. Not doing so may result in electrical shock.

 **WARNING** Do not damage, pull on, apply stress to, place heavy objects on, or pinch the cables. Doing so may result in electrical shock, operation stoppage, or burning.

 **WARNING** Do not attempt to disassemble or repair the Unit. Doing either of these may result in electrical shock, injury, or damage to the product.

 **Caution** Do not store, install, or operate the product in the following places. Doing so may result in electrical shock, fire or damage to the product.

- Locations subject to direct sunlight.
- Locations subject to temperatures or humidity outside the range specified in the specifications.
- Locations subject to condensation as the result of severe changes in temperature.
- Locations subject to corrosive or flammable gases.

- Locations subject to exposure to combustibles.
- Locations subject to dust (especially iron dust) or salts.
- Locations subject to exposure to water, oil, or chemicals.
- Locations subject to shock or vibration.

 **Caution** Do not allow foreign objects to enter inside the product. Doing so may result in fire or malfunction.

 **Caution** Do not apply any strong impact. Doing so may result in damage to the product or malfunction.

 **Caution** Be sure to wire correctly and securely. Not doing so may result in injury or damage to the product.

 **Caution** Be sure to firmly tighten the screws on the terminal block. Not doing so may result in fire, injury, or damage to the product.

 **Caution** Carefully handle the product because it uses semiconductor elements. Careless handling may result in malfunction.

 **Caution** Take appropriate and sufficient countermeasures when installing systems in the following locations. Not doing so may result in equipment damage.

- Locations subject to static electricity or other forms of noise.
- Locations subject to strong electromagnetic fields and magnetic fields.
- Locations subject to possible exposure to radioactivity.
- Locations close to power supplies.

■ Operation and Adjustment Precautions

 **Caution** Do not carelessly change Inverter's settings. Doing so may result in injury or damage to the product.

 **Caution** Be sure to perform the setting switch settings correctly and confirm the settings before starting operation. Not doing so may result in malfunction or damage to the product.

Table of Contents

Chapter 1. Functions and System Configuration 1-1

1-1	Functions	1-2
1-2	New Functions	1-5
1-3	DeviceNet Features	1-6
1-4	DeviceNet System Configuration	1-8
1-4-1	System Configuration	1-8
1-4-2	Configurator Overview	1-10
1-4-3	DeviceNet Communications Specifications	1-11
1-4-4	Inverters	1-12

Chapter 2. DeviceNet Communications Line Design 2-1

2-1	Network Configuration Overview	2-2
2-1-1	Network Components	2-2
2-1-2	Connections	2-3
2-2	Network Configuration Restrictions	2-4
2-2-1	Baud Rate and Communications Distance	2-4
2-2-2	Locating Terminating Resistors	2-5
2-3	Communications Power Supply	2-6
2-3-1	Locating the Communications Power Supply	2-6
2-3-2	Step 1: Determining the Best Location for the Power Supply from a Graph	2-9
2-3-3	Step 2: Calculating the Best Location of the Actual Nodes	2-11
2-3-4	Step 3: Splitting the System into Multiple Power Supplies	2-13
2-3-5	Dual Power Supplies	2-14
2-4	Communications Line Noise Prevention	2-15
2-4-1	Communications Line Noise	2-15
2-4-2	Grounding the Network	2-15
2-4-3	Communications Power Supply Noise Prevention	2-16
2-4-4	Noise Prevention Wiring	2-17
2-4-5	Noise Prevention for Peripheral Devices	2-18

Chapter 3. Setup and Wiring 3-1

3-1	Nomenclature and Settings	3-2
3-1-1	Names of Parts	3-2
3-1-2	Terminal Block	3-2
3-1-3	Operation Indicators	3-3
3-1-4	Baud Rate and Node Address Settings	3-3
3-2	Installation and Wiring	3-5
3-2-1	DeviceNet Communications Unit Installation	3-6
3-2-2	Communications Cable Wiring	3-8

Chapter 4. DeviceNet System Startup 4-1

4-1	SYSMAC Word Allocations and Scan List	4-2
4-1-1	Overview and Restrictions of Word Allocations	4-2
4-1-2	Scan List	4-5
4-1-3	Fixed Word Allocations	4-7
4-1-4	Free Allocations	4-13
4-2	SYSDRIVE 3G3MV Settings	4-19
4-2-1	Run Command Selection	4-19
4-2-2	Frequency Reference Selection	4-20
4-2-3	Frequency Reference Settings and Display Units	4-21
4-3	Startup Procedure	4-22

Table of Contents

Chapter 5. DeviceNet Communications Unit Operations 5-1

5-1	Remote I/O	5-2
5-1-1	Standard Remote I/O (Initial Setting)	5-3
5-1-2	Types of Remote I/O Operation	5-5
5-2	Switching Remote I/O Operation	5-9
5-3	Special Remote I/O Operation	5-12
5-3-1	Overview of Special Remote I/O	5-12
5-3-2	Special Remote I/O Communications Timing	5-14
5-3-3	Parameter Register Numbers for Each Function	5-15
5-4	Control Remote I/O Operation	5-16
5-5	Message Communications (DeviceNet Explicit Messages)	5-20
5-5-1	Overview of Message Communications (Explicit Message Operations)	5-20
5-5-2	Sending and Receiving Messages with CS1W-DRM21 or CJ1W-DRM21 DeviceNet Unit	5-21
5-5-3	Sending and Receiving Messages with a C200HW-DRM21-V1 DeviceNet Master Unit	5-24
5-5-4	CVM1-DRM21-V1 DeviceNet Master Unit Message Transmission	5-29
5-5-5	Overview of Messages and Responses	5-32
5-5-6	Motor Data Objects: Class 28 Hex	5-33
5-5-7	Control Supervisor Objects: Class 29 Hex	5-34
5-5-8	AC/DC Drive Objects: Class 2A Hex	5-37
5-5-9	Reading and Writing Parameters: Class 64 Hex	5-40
5-6	3G3MV Register Numbers, Classes, Instances, and Attributes	5-42
5-6-1	Inputting Control/Frequency	5-42
5-6-2	Inverter Monitoring Functions	5-44
5-6-3	Parameter Reading and Writing	5-48

Chapter 6. Communications Errors 6-1

6-1	Communications Line Errors	6-2
6-2	Message Communications Errors	6-5
6-3	Special Remote I/O Errors	6-6
6-4	Inverter Faults	6-7

Chapter 7. Communications Programs (SYSMAC CS-series PCs) .. 7-1

7-1	Standard Remote I/O Programming	7-2
7-2	Message Communications Programming	7-5
7-2-1	Inverter Fault Processing	7-5
7-2-2	Reading/Writing Data	7-9
7-3	Special Remote I/O Programs	7-13
7-3-1	Simple Operation Programs	7-13
7-3-2	Reading Parameter Data	7-19
7-3-3	Writing Parameter Data	7-22

Table of Contents

Chapter 8. Appendices	8-1
8-1 Specifications	8-2
8-2 Objects	8-4
8-2-1 Identify Objects (Identification Information): Class 01 Hex	8-4
8-2-2 Message Router Objects: Class 02 Hex	8-5
8-2-3 DeviceNet Objects: Class 03 Hex	8-6
8-2-4 Assembly Objects: Class 04 Hex	8-7
8-2-5 DeviceNet Connection Objects: Class 05 Hex	8-9
8-3 DeviceNet Communications Response Time	8-13
Index	I-1
Revision History	R-1

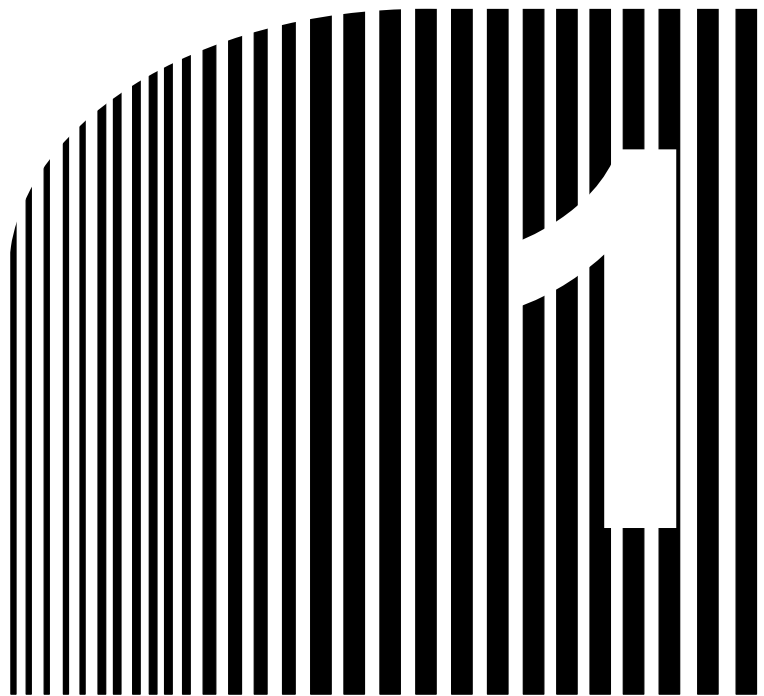

Chapter 1

• Functions and System Configuration •

- 1-1 Functions
- 1-2 New Functions
- 1-3 DeviceNet Features
- 1-4 DeviceNet System Configuration

1-1 Functions

The 3G3MV-PDRT1-SINV1 DeviceNet Communications Unit is a dedicated communications interface Unit that makes it possible for the SYSDRIVE 3G3MV Multi-function Compact Inverter to communicate with SYSMAC Programmable Controllers. Installing a DeviceNet Communications Unit in the SYSDRIVE 3G3MV Inverter permits a Programmable Controller to monitor RUN/STOP and operating conditions, and to make changes in set values.

Note When the DeviceNet Communications Unit is used, the RS-422/485 of the Inverter cannot be used for communications.

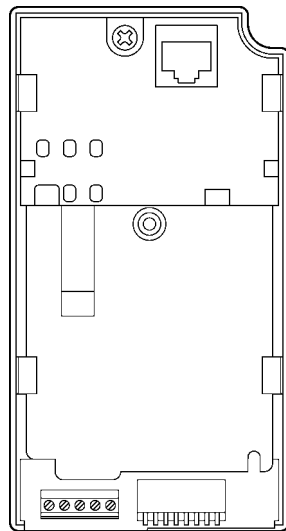

3G3MV-PDRT1-SINV1
DeviceNet Communications Unit

■ Easy Communications

The following two functions can be used simultaneously in DeviceNet communications between the CPU Unit of a SYSMAC PC and the SYSDRIVE 3G3MV Inverter.

- Remote I/O Communications

I/O is automatically transferred between Slaves and the CPU Unit without any special programming in the CPU Unit. (Automatically transmits Inverter control inputs such as RUN or STOP from a SYSMAC PC to the SYSDRIVE 3G3MV Inverter and returns operation status of the Inverter or output frequency monitor data.)

- Message Communications

Message communications are performed between a CPU Unit to which a Master Unit is mounted and Slaves (SYSDRIVE 3G3MV Inverters) by executing specific instructions (such as CMND and IOWR, depending on the model of SYSMAC PC used) from the program in the CPU Unit. (Allows some parameter setting and monitoring, Inverter output frequency, output voltage, or output current. If the remote I/O communications is not performed, Inverter control data such as RUN or STOP can be input through this message communications function.)

Remote I/O communications for the DeviceNet Communications Unit are performed using either 4 or 8 words allocated in the I/O Area of the SYSMAC PC. The Inverter can be controlled using remote I/O communications because the basic control I/O functions, frequency setting functions, and output frequency monitoring functions are assigned to remote I/O. This allows the Inverter to be controlled through simple I/O processing.

■ Communications with SYSMAC CS/CJ-series, SYSMAC C200HX/HG/HE, and CV-series PCs

The DeviceNet communications system is supported by SYSMAC CS/CJ-series, SYSMAC C200HX/HG/HE and CV-series Programmable Controllers. Up to twice as many Inverters can be connected in comparison to SYSMAC BUS Remote I/O Systems to support even larger control systems.

Note 1. The maximum number of nodes that can be connected to the system depends on the type of Master Unit used, whether the message function is used, and the number of words used by remote I/O communications. See *1-4 DeviceNet System Configuration* for further details.

Note 2. The SYSMAC CS Series includes the CS1G and CS1H Programmable Controllers. The SYSMAC CJ Series includes the CJ1G Programmable Controllers. The SYSMAC CV Series includes the CV1000, CV2000, and CVM1 Programmable Controllers. SYSMAC C200HS PCs support only remote I/O communications.

■ Multi-vendor Network

The DeviceNet conforms to the DeviceNet open field network specification, which means that devices (Masters and Slaves) produced by other manufacturers can also be connected to the Network. The DeviceNet Communications Unit supports the DeviceNet AC/DC drive object.

■ Choice of Communications Functions

The DeviceNet Communications Unit has various functions to choose from to suit the Inverter applications.

- Remote I/O Communications

Either basic remote I/O control or special remote I/O can be chosen for remote I/O allocation to suit the application. Special I/O control can be used to control and set all functions for 3G3MV Inverters.

- Message Communications

Basic Inverter control and monitoring is possible with DeviceNet explicit messages, which are defined for AC/DC driver objects. Remote I/O and message communications can be used simultaneously, i.e., remote I/O control can be performed at the same time as other control using message communications.

■ Applicable to Various System Configurations

Remote I/O communications and message communications are available as communications functions. Normal control inputs are controlled by the remote I/O communications function. When necessary, the message communications function is used to monitor each Inverter. It is possible to control the selection of either the communications control input or local control input.

Note For connecting the DeviceNet Communications Unit of the Inverter, use DCA1-5C10 Thin Cables and branch them from the T-branch Tap.

Thick Cables cannot be used for this kind of wiring because of the terminal block dimensions. As for multi-drop wiring, use Thin Cables for direct insertion. Thick Cables cannot be used for this kind of wiring.

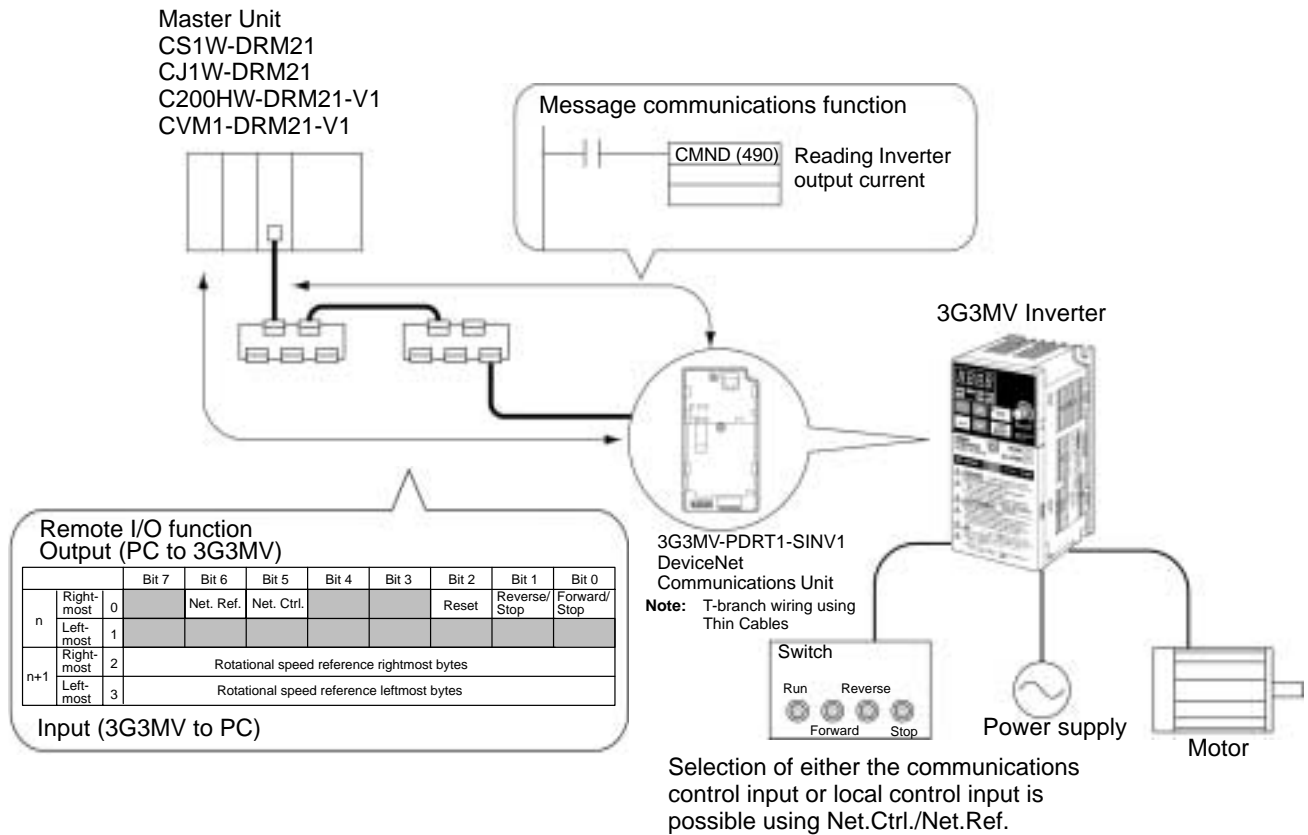

1-2 New Functions

The software of the previous DeviceNet Communications Unit (3G3MV-PDRT1-SINV) has been upgraded with this model (3G3MV-PDRT1-SINV1), and new functions have been added.

Note The upgraded software used with this model is Ver. 2.0. The software version can be confirmed using the Configurator.

■ New Remote I/O Function

A new remote I/O function has been added to the three existing functions (basic remote I/O, standard remote I/O, and special remote I/O). The new remote I/O, called control remote I/O, contains functionality and arrays matching the Inverter control terminal I/O signals, and it provides easy-to-use specifications for reduced wiring.

Note The control remote I/O function does not conform to the AC/DC drive profile, but is specially set for this product.

■ Changes to Remote I/O Switching Methods

The four types of remote I/O functions use explicit messages for switching. The following table shows the changed area settings for the remote I/O to be set.

Item	Original area (before changes)	New area (after changes)
Remote input switching (SYSMAC ← Inverter)	Class: 100 (64 Hex)	Class: 101 (65 Hex)
	Instance: 01 (01 Hex)	Instance: 01 (01 Hex)
	Attribute: 202 (CA Hex)	Attribute: 01 (01 Hex)
Remote output switching (SYSMAC → Inverter)	Class: 100 (64 Hex)	Class: 101 (65 Hex)
	Instance: 01 (01 Hex)	Instance: 01 (01 Hex)
	Attribute: 203 (CB Hex)	Attribute: 02 (02 Hex)

■ Parameter Reading and Writing Using Explicit Messages

An event parameter reading and writing function has been added that uses explicit messages. Although previously it was necessary to set special remote I/O to read and write parameters, explicit messages can now be used so that remote I/O can be selected more freely.

■ New Communications Power Supply Interrupt Detection Function

A function has been added that detects interruptions in the communications power supply and detects errors if the DeviceNet communications power supply falls below the specified voltage.

1-3 DeviceNet Features

■ System Configuration Example

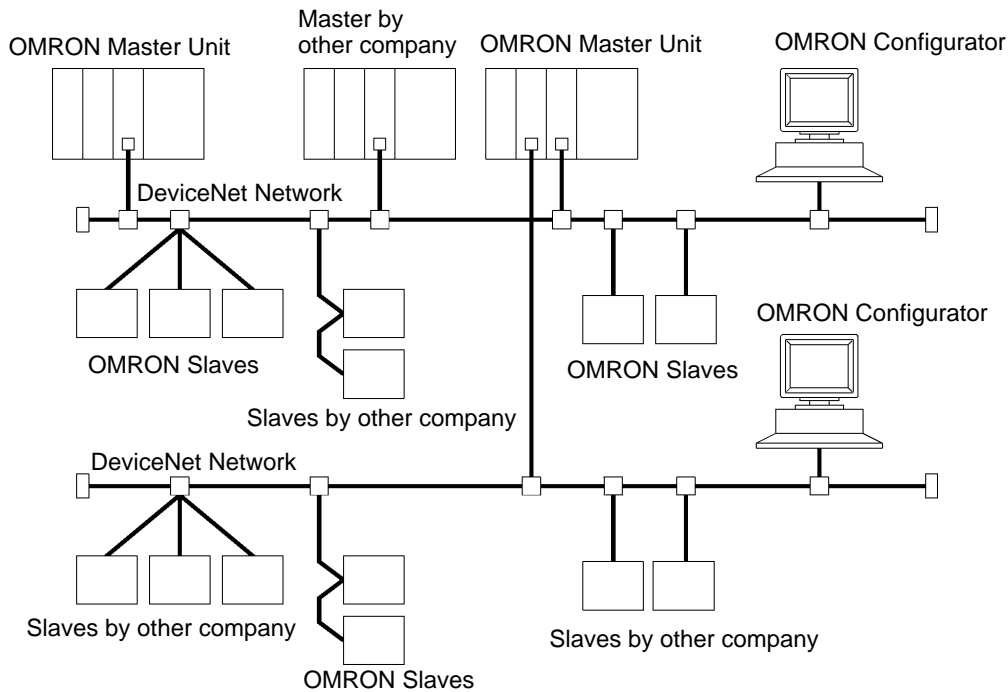

■ Multi-vendor Network

The DeviceNet conforms to the DeviceNet open field network specification, which means that devices (Masters and Slaves) produced by other manufacturers can also be connected to the Network. Therefore, a wide range of field-level applications can be supported by combining valve devices, sensors, and other devices.

■ Simultaneous Remote I/O and Message Services

Remote I/O communications to constantly exchange I/O data between the PC and Slaves can be executed simultaneously with message communications, to send/receive Master Unit data as required by the application. Therefore, a DeviceNet Network can be installed to flexibly handle applications that require both bit data and message data. Message communications can be achieved either by using OMRON's FINS commands or by using DeviceNet explicit messages.

■ Connect Multiple PCs to the Same Network

A Configurator (sold separately) can be used to enable connection of more than one Master to the Network, allowing message communications between PCs and between multiple groups of PCs and Slaves. This allows the DeviceNet Network to be used as a common bus to unify controls while reducing wiring.

■ Handle Multi-point Control and Line Expansions with Multi-layer Networks

A Configurator (sold separately) can be used to enable mounting more than one Master Unit to a single PC, allowing control of many more points. This feature can easily handle line expansions and other applications.

■ **Free Remote I/O Allocation**

A Configurator (sold separately) can be used to enable flexible allocation of I/O, i.e., in any area and in any order. This allows I/O allocations that suit the application to simplify programming and enable effective usage of PC memory areas.

■ **Handle Slaves with Different Response Speeds**

A Configurator (sold separately) can be used to set the communications cycle time, enabling usage of Slaves with slow response times.

■ **Easily Expand or Change Lines with Various Connection Methods**

Use a multi-drop trunk line, T-branch multi-drop lines, or daisy-chain drop lines. All three connection methods can be combined to flexibly construct a Network that meets the needs of the application.

Note For connecting the DeviceNet Communications Unit of the Inverter, use DCA1-5C10 Thin Cables and branch them from the T-branch Tap.

1-4 DeviceNet System Configuration

1-4-1 System Configuration

DeviceNet is a multi-bit, multi-vendor network that combines controls and data on a machine/line-control level and that conforms to DeviceNet open field network specifications.

Two types of communications are supported: 1) Remote I/O communications that automatically transfer I/O between Slaves and the CPU Unit of a SYSMAC PC without any special programming in the CPU Unit and 2) Message communications are performed between a CPU Unit to which a Master Unit is mounted and Slaves by executing specific instructions (such as CMND and IOWR, depending on the model of SYSMAC PC used) from the program in the CPU Unit.

A Configurator (sold separately) can be used to enable following. This allows the support of an even larger control system.

- I/O area words can be flexibly allocated for remote I/O communications.
- More than one Master Unit can be mounted to a single PC.
- More than one Master Unit can be connected in a single Network.

■ Fixed Allocation: Configuration without a Configurator

DeviceNet Master Unit
 CS1W-DRM21
 CJ1W-DRM21
 C200HW-DRM21-V1
 CVM1-DRM21-V1

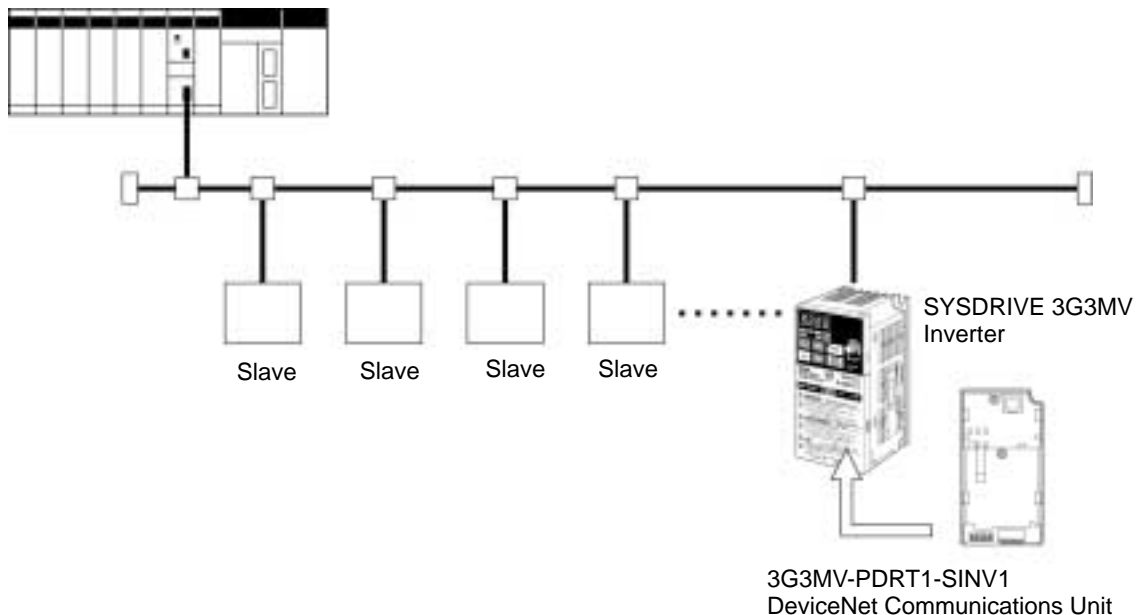

CS/CJ-series PCs:	64 nodes max. (including the Master Unit)
CV-series PCs:	64 nodes max. (including the Master Unit)
C200HX/HG/HE PCs:	64 nodes max. (including the Master Unit)
C200HS PCs:	33 nodes max. (including the Master Unit)

Note 1. The Master Unit occupies one node of the DeviceNet Network.

Note 2. If C200HS PCs are used, only remote I/O communications are possible.

Note 3. If one node uses more than one word, the maximum number of nodes will be reduced by one node for each extra word that is used.

■ **Free Allocation: Configuration with a Configurator**

DeviceNet Master Unit
 CS1W-DRM21
 CJ1W-DRM21
 C200HW-DRM21-V1
 CVM1-DRM21-V1

3G8F5-DRM21 (ISA Board)
 or
 SG8E2-DRM21 (PC Card)
 Configurator

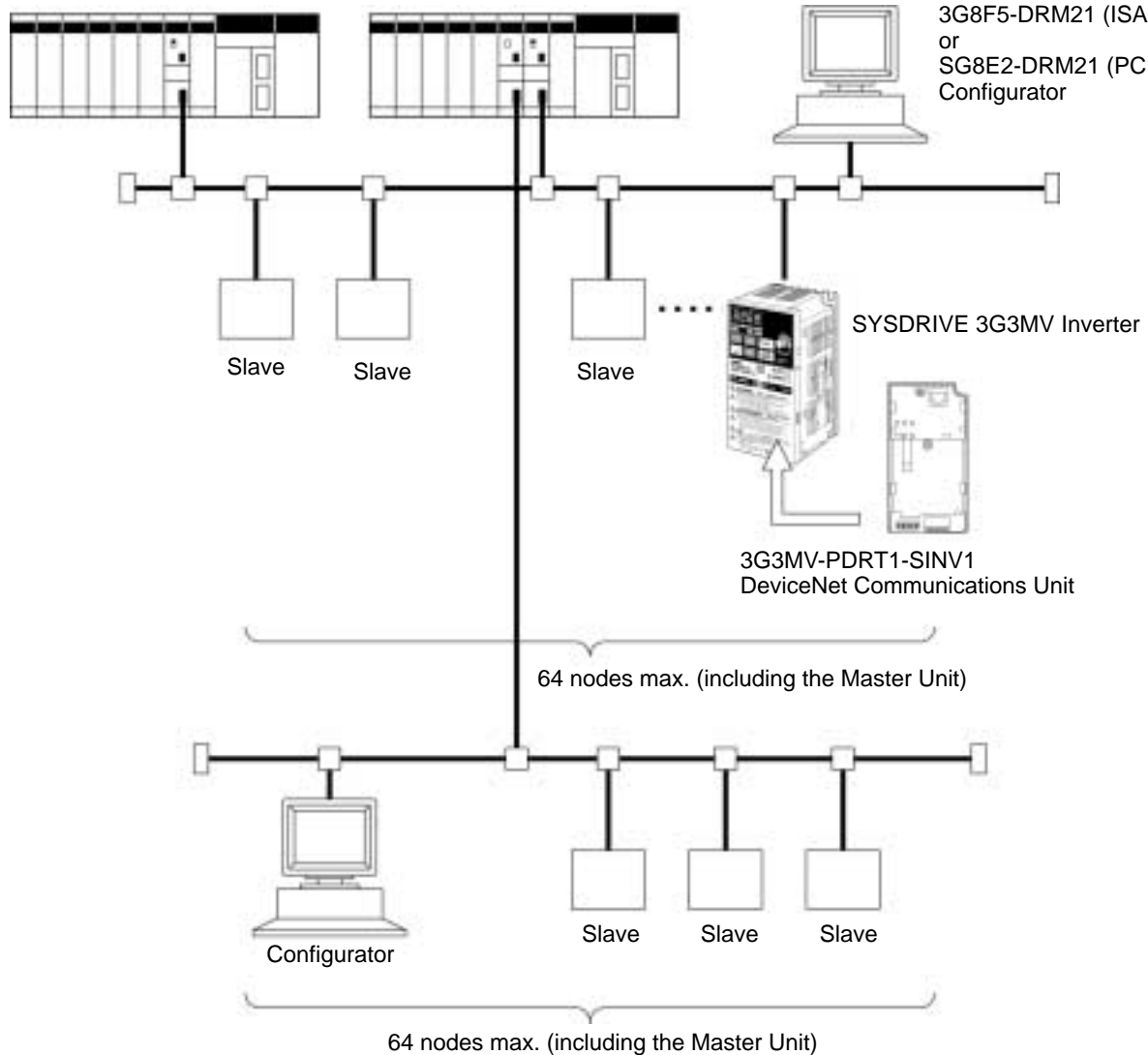

Note 1. The Master Unit and Configurator each occupy one node of the DeviceNet Network.

Note 2. If C200HS PCs are used, only remote I/O communications are possible.

Note 3. The maximum number of nodes that can be connected to the Network will be limited by the maximum number of control points of the PC used.

1-4-2 Configurator Overview

The Configurator is a software application run on an IBM PC/AT or compatible computer and is used to support a DeviceNet communications system. Connection to the Network is achieved either via a serial communications port (peripheral bus or Host Link) or by connecting the computer directly to the DeviceNet using a hardware interface. The Configurator occupies one node on the DeviceNet Network, but has no specific functions on the network itself. The Configurator provides the following functions.

- Free Allocation of Remote I/O
 - The remote I/O allocations in the PCs can be changed from the Configurator. I/O can be flexibly allocated for each node within the specified I/O areas.
- More than One Master Unit per Network
 - Slaves can be set for each Master Unit from the Configurator enabling communications between multiple groups of PCs and Slaves. The maximum number of nodes connected to one Network remains at 64. One Slave can be connected to no more than one Master Unit.
- More than one Master Unit per PC
 - Remote I/O can be allocated for each Slave of the Master Unit from the Configurator, so more than one Master Unit can be mounted to the same PC.

Note In allocating Remote I/O for each Master Unit, be careful not to allow any dual allocation.

■ Configurator Specifications

Item		WS02-CFDC1-E	3G8F5-DRM21	3G8E2-DRM21
Personal computer		---	Desktop model	Notebook model
Components		Installation disk (software)	Installation disk (software) Dedicated ISA Board	Installation disk (software) Dedicated PCMCIA Card DeviceNet Interface Unit
Operating environment	Hardware	Computer: IBM PC/AT or compatible CPU: Windows NT: 166 MHz Pentium min. Memory: 32 MB min. Hard disk: 15 MB min. free space		
	OS	Windows 95, 98, 2000, or NT 4.0		
	DeviceNet interface	No accessories	Dedicated ISA Board	Dedicated PCMCIA Card DeviceNet Interface Unit
Relation to Network		Operates as one node on the Network, requires one node address, and only one Configurator can be connected to the Network. (The Configurator can be disconnected from the Network after remote I/O has been allocated.)		

1-4-3 DeviceNet Communications Specifications

Item		Specifications
Communications protocol		DeviceNet
Supported connections (communications)		Master-Slave: Remote I/O and explicit messages Peer-to-peer: FINS messages Both conform to DeviceNet specifications.
Connection forms		Combination of multi-drop and T-branch connections (for trunk and drop lines)
Baud rate		500 Kbps, 250 Kbps, or 125 Kbps (switchable)
Communications media		Special 5-wire cables (2 signal lines, 2 power lines, and 1 shield line) Thick Cable: DCA2-5C10 (100 m) Thin Cable: DCA1-5C10 (100 m)
Communications distances	500 Kbps	Network length: 100 m max. Drop line length: 6 m max. Total drop line length: 39 m max.
	250 Kbps	Network length: 250 m max. Drop line length: 6 m max. Total drop line length: 78 m max.
	125 Kbps	Network length: 500 m max. Drop line length: 6 m max. Total drop line length: 156 m max.
Communications power supply		24 V DC \pm 1%, supplied externally (Slave power supply: 11 to 25 V DC) Recommended power supply: OMRON S82H Series or S82J Series
Maximum number of nodes		64 nodes
Maximum number of Masters		Without Configurator: 1 With Configurator: 63
Maximum number of Slaves		Without Configurator: 63 With Configurator: 63
Error control		CRC check

1-4-4 Inverters

The maximum number of Inverters that can be connected to one Network depends on the PC model that is used, the remote I/O functions of the Inverter, and whether message communications are used or not. (Use the message communications function for setting some parameters and for monitoring the output current.) The differences between models are provided in the following tables.

■ CS1W-DRM21 or CJ1W-DRM21 Master Units

● Communications without Configurator: Fixed Allocations

Applicable PC		CS Series	CJ Series
Master Unit		CS1W-DRM21	CS1J-DRM21
Supported communications		Remote I/O and messages	
Maximum number of Slaves per Master Unit		63	
Maximum number of controlled points per Master Unit		2,048	
Allocation areas		Select one of the following settings, using the software switch (Fixed Area Setting 1, 2, or 3 Switch) in the words allocated to the Master Unit in the CIO Area: 1. OUT: CIO 3200 to CIO 3263; IN: CIO 3300 to CIO 3363 (default) 2. OUT: CIO 3400 to CIO 3463; IN: CIO 3500 to CIO 3563 3. OUT: CIO 3600 to CIO 3663; IN: CIO 3700 to CIO 3763	
Allocation method		Words are allocated for each node to the above data areas in node address order only. 8-point Slaves: Allocated 1 word (1 node address) 16-point Slaves: Allocated 1 word (1 node address) Slaves with more than 16 points: Allocated multiple words (multiple node addresses)	
Maximum number of Inverters	Without explicit messages	4 words remote I/O: 32 6 words remote I/O: 21 8 words remote I/O: 16	
	With explicit messages	4 words remote I/O: 32 6 words remote I/O: 21 8 words remote I/O: 16	

● Communications with Configurator: Free Allocations

Applicable PC		CS Series	CJ Series
Master Unit		CS1W-DRM21	CS1J-DRM21
Supported communications		Remote I/O and messages	
Maximum number of Slaves per Master Unit		63	
Maximum number of controlled points per Master Unit		Using Settings in Words Allocated in DM Area: 16,000 points (IN: 500 words × 1 block; OUT: 500 words × 1 block) Using Configurator: 32,000 points (IN: 500 words × 2 blocks; OUT: 500 words × 2 blocks)	

Applicable PC	CS Series	CJ Series
Allocation areas	CIO 0000 to CIO 6143 WR: W000 to W511 HR: H000 to H511 DM: D00000 to D32767 EM: E00000 to E32767	
Allocation method	<p>Words are allocated to each node in the above data areas in any order.</p> <p>The following limitations apply:</p> <ul style="list-style-type: none"> • Using Settings in Words Allocated to Master Unit in DM Area: The following limitations apply when allocating words using settings in the DM Area. Words are allocated in 2 blocks (OUT 1, IN 1). Each block consists of sequential words. Words for each slave are allocated inside the allocated words in order of node number. (It is not necessary to allocate words to unused node numbers.) The leftmost byte of a word cannot be allocated to an 8-point Slave. • Using the Configurator: Using the Configurator allows much wider allocation than using settings in the DM Area. Words are allocated in 4 blocks (OUT 1, OUT 2, IN 1, IN 2). Each block consists of sequential words. Words for each slave can be allocated inside the allocated words in any order. • Limitations That Apply to Both Methods The following limitations apply when allocating words using either settings in the DM Area or using the Configurator. The maximum that can be allocated in one block is 500 words. For Slaves with more than 8 points, the first byte cannot be specified as the leftmost byte (7 to 15). The same Slave cannot be used for more than one Master Unit. Words are allocated to Slaves as follows: <ul style="list-style-type: none"> • 8-point Slaves: Allocated leftmost or rightmost byte of a word. • 16-point Slaves: Allocated 1 word. • Slaves with more than 16 points: Allocated multiple words (for Slaves with an odd number of bytes, the last byte will be the rightmost byte). 	
Maximum number of Inverters (using one Master Unit only)	63	
Maximum number of Inverters with more than one Master Unit	Calculate from the number of words allocated in the data areas and the number of words allocated to the Inverters (4 to 8 words). The DM Area cannot be manipulated by bit, so it cannot be allocated for remote I/O for Inverters.	

■ C200HW-DRM21-V1 or CVM1-DRM21-V1 Master Units

● Communications without Configurator: Fixed Allocation

Applicable PC		CV Series	CS Series and C200HX/HG/HE	C200HS
Master Unit		CVM1-DRM21-V1	C200HW-DRM21-V1	
Supported communications		Remote I/O and messages	Remote I/O and messages	Remote I/O
Maximum number of Slaves per Master Unit		63	50	32
Maximum number of controlled points per Master Unit		2,048	1,600	1,024
Allocation areas		OUT: CIO 1900 to CIO 1963 IN: CIO 2000 to CIO 2063	OUT: IR 050 to IR 099 IN: IR 350 to IR 399	OUT: IR 50 to IR 81 IN: IR 350 to IR 381
Allocation method		Words are allocated for each node to the above data areas in node address order only. 8-point Slaves: Allocated 1 word 16-point Slaves: Allocated 1 word Slaves with more than 16 points: Allocated multiple words		
Maximum number of Inverters	Without explicit messages	4 words remote I/O: 32 6 words remote I/O: 21 8 words remote I/O: 16	4 words remote I/O: 25 6 words remote I/O: 16 8 words remote I/O: 12	4 words remote I/O: 16 6 words remote I/O: 10 8 words remote I/O: 8
	With explicit messages	4 words remote I/O: 32 6 words remote I/O: 21 8 words remote I/O: 16	4 words remote I/O: 25 6 words remote I/O: 16 8 words remote I/O: 12	---

● Communications with Configurator: Free Allocation

Applicable PC		CV Series	CS Series and C200HX/HG/HE	C200HS
Master Unit		CVM1-DRM21-V1	C200HW-DRM21-V1	
Supported communications		Remote I/O and messages	Remote I/O and messages	Remote I/O
Maximum number of Slaves per Master Unit		63	63	63
Maximum number of controlled points per Master Unit		6,400 (100 words × 4 blocks)	Without messages: 4,800 With messages: 1,600	1,280 (total of 4 blocks)

Applicable PC		CV Series	CS Series and C200HX/HG/HE	C200HS
Allocation areas		Core I/O Area: CIO 0000 to CIO 2555 CIO 0000 to CIO 2427 for CV500/CVM1-CPU01(-V□)	IR Area 1: IR 000 to IR 235 IR Area 2: IR 300 to IR 511	
		CPU Bus Link Area: G008 to G255	<u>CS1</u> HR: H000 to H099 CIO: 1000 to 1063 <u>C200HX/HG/HE</u> HR Area: HR 00 to HR 99 LR Area: LR 00 to LR 63	HR Area: HR 00 to HR 99 LR Area: LR 00 to LR 63
		DM Area: D00000 to D24575 D00000 to D08191 for CV500/CVM1-CPU01 (-V□)	<u>CS1</u> DM: D00000 to D05999 <u>C200HX/HG/HE</u> DM: DM 0000 to DM 5999 (DM 0000 to DM 4095 for C200HE-CPU11-(Z)E)	DM Area: DM 0000 to DM 5999
Allocation method		<p>Words are allocated to each node in the above data areas in any order using the Configurator.</p> <p>The following limitations apply:</p> <p style="padding-left: 40px;">The allocation areas are in 4 blocks (OUT 1, OUT 2, IN 1, and IN 2). Each block consists of sequential words.</p> <p style="padding-left: 40px;">100 words max. per block.</p> <p style="padding-left: 40px;">For Slaves with more than 8 points, the first byte cannot be specified in leftmost bits (7 to 15).</p> <p>Words are allocated to Slaves as follows:</p> <p>8-point Slaves: Allocated leftmost or rightmost byte of 1 word</p> <p>16-point Slaves: Allocated 1 word</p> <p>Slaves with more than 16-points: Allocated multiple words (For Slaves with an odd number of bytes, the last byte will be the rightmost byte)</p>		
Maximum number of Inverters (using one Master Unit only)	Without explicit messages	63	4 remote I/O words: 63 6 remote I/O words: 50 8 remote I/O words: 37	4 words remote I/O: 20 6 words remote I/O: 13 8 remote I/O words: 10
	With explicit messages	63	4 remote I/O words: 25 6 remote I/O words: 16 8 remote I/O words: 12	---
Maximum number of Inverters with more than one Master Unit		<p>Calculate from the number of words allocated in the data areas and the number of words allocated to the Inverters (4 or 6 words).</p> <p>Note 1. The DM Area cannot be manipulated by bit, so it cannot be allocated for remote I/O for Inverters.</p> <p>Note 2. If the CPU Bus Link is used with a CV-series PC, the CPU Bus Link Area will be used for the CPU Bus Link Therefore, the CPU Bus Link Area cannot be allocated to Inverters if the CPU Bus Link is used.</p>		

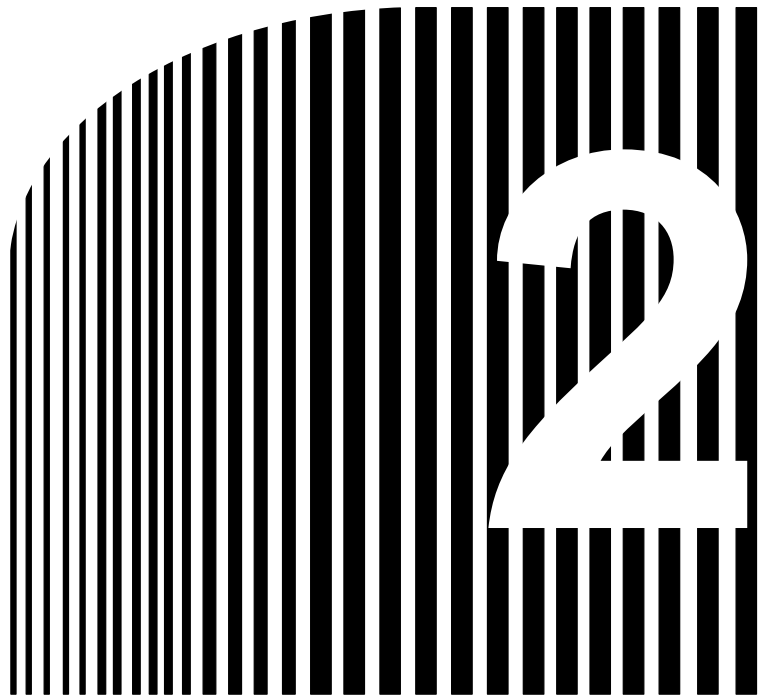

Chapter 2

- **DeviceNet
Communications Line
Design** •

- 2-1 Network Configuration Overview
- 2-2 Network Configuration Restrictions
- 2-3 Communications Power Supply
- 2-4 Communications Line Noise Prevention

2-1 Network Configuration Overview

The following diagram shows the configuration of a DeviceNet Network.

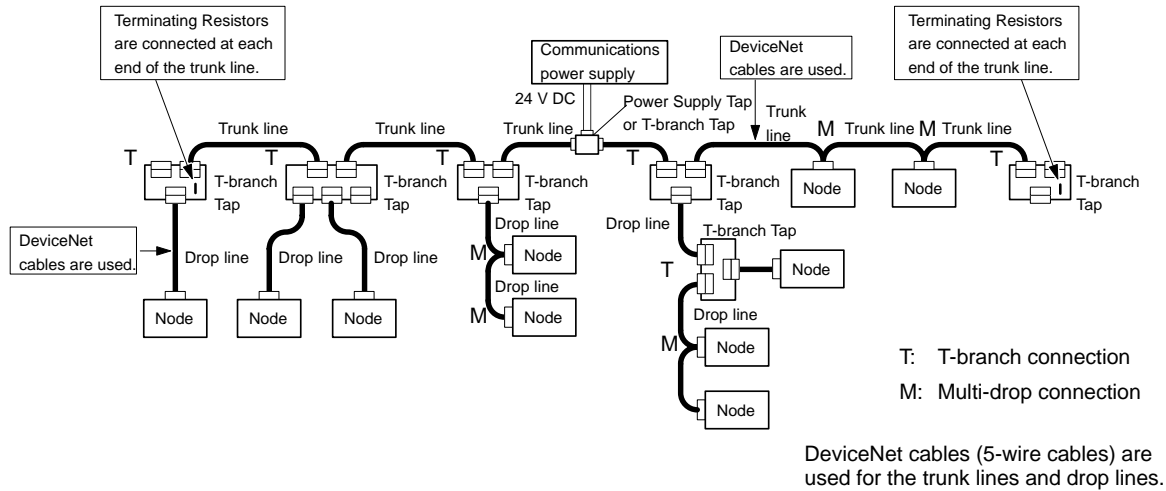

2-1-1 Network Components

■ Nodes

There are two kinds of nodes on a DeviceNet Network: The Master and Slaves. The Slaves connect to external I/O and the Master administers the Network and manages the external I/O of the Slaves. The Master and Slaves can be connected at any location in the Network, as shown in the preceding diagram.

■ Trunk/Drop Lines

The trunk line refers to the cable that has Terminating Resistors on both ends. Cables branching from the trunk line are known as drop lines. The trunk line length does not necessarily coincide with the maximum length of the Network. DeviceNet communications are transmitted through 5-wire cables. The cables come in thick and thin versions.

■ Connection Methods

Two methods can be used to connect DeviceNet nodes: The T-branch method and the multi-drop method. With the T-branch method, the node is connected to a drop line created with a T-branch Tap. With the multi-drop method, the node is directly connected to the trunk line or the drop line. Secondary branches can be made from a drop line. Both of these connection methods can be used in the same Network.

■ Terminating Resistors

Terminating Resistors are connected at each end of the trunk line to reduce signal reflection and stabilize communications. There are two kinds of Terminating Resistors available: One that is provided with a T-branch Tap and a Terminal-block Terminating Resistor. Use a DeviceNet Cable when connecting a Terminal-block Terminating Resistor.

■ Communications Power Supplies

To use DeviceNet, connect a communications power supply to the communications connector of each node with a 5-wire cable. Basically, a communications power supply, internal circuit power supply, and I/O power supply must be provided separately.

2-1-2 Connections

■ Trunk and Drop Lines

The trunk line is a cable to which Terminating Resistors are connected at the ends. Drop lines are cables that branch from the trunk lines. A special 5-wire cable is used for both the trunk lines and the drop lines.

■ Branching Patterns

Branching Patterns from Trunk Line

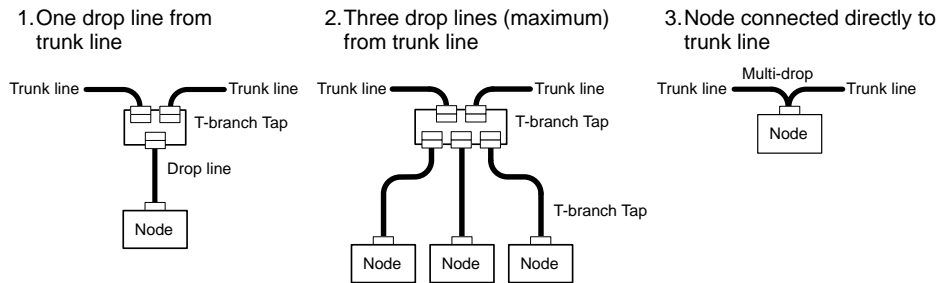

Branching Patterns from Drop Line

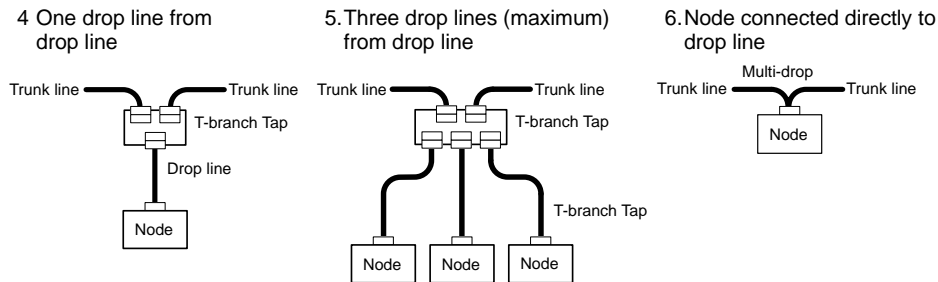

Various forms of connection can be used on the same Network, as shown in the following diagram. Any number of nodes up to 63 can be connected onto a single drop line.

Note Design the Inverter wiring for T-branch wiring purposes using Thin Cables.

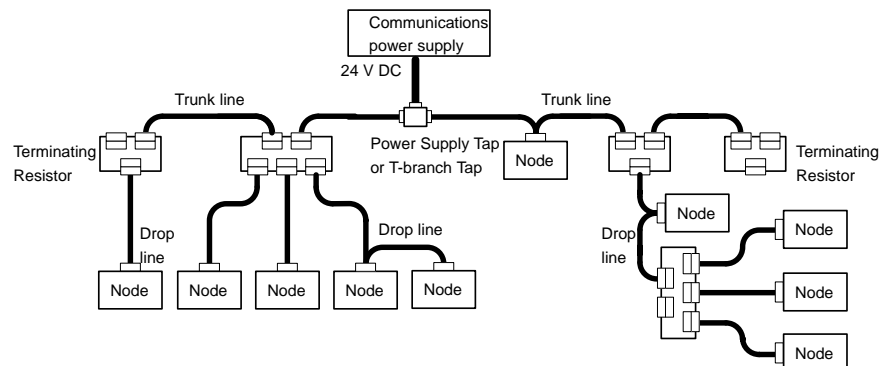

2-2 Network Configuration Restrictions

DeviceNet communications are designed to meet a wide range of applications by providing a choice of baud rates and allowing different combinations of T-branch and multi-drop connections. The restrictions of DeviceNet communications that are required to enable the various communications possibilities are described here.

2-2-1 Baud Rate and Communications Distance

The maximum length of the DeviceNet communications cables is restricted by the baud rate and the type of cable used. The three types of restrictions on DeviceNet communications cable length are as follows:

- Maximum network length
- Drop line length
- Total drop line length

Be sure to design and configure a Network that meets the conditions provided below to ensure reliable communications.

■ Maximum Communications Distance

Baud rate	Maximum network length		Drop line length	Total drop line length
	Thick Cable	Thin Cable		
500 kbps	100 m max.	100 m max.	6 m max.	39 m max.
250 kbps	250 m max.	100 m max.	6 m max.	78 m max.
125 kbps	500 m max.	100 m max.	6 m max.	156 m max.

Note Thick Cable (5-wire): DCA2-5C10 (100 m)
Thin Cable (5-wire): DCA1-5C10 (100 m)

■ Maximum Network Length

The length of the Network is longest at either the distance between the two most distant nodes or at the distance between the Terminating Resistors.

There are two types of cables: Thick Cables and Thin Cables. The cable thickness affects signal deterioration. The maximum length of the Network therefore depends on the type of cable used as shown in the previous table.

The following restrictions apply to Networks in which both Thick and Thin Cables are combined.

Baud rate	Maximum Network length
500 kbps	Thick Cable length + Thin Cable length \leq 100 m
250 kbps	Thick Cable length + 2.5 \times Thin Cable length \leq 250 m
125 kbps	Thick Cable length + 5.0 \times Thin Cable length \leq 500 m

■ Drop Line Length

The length of the drop line is measured from the point in the trunk line where the original branch was made to the end of the branch. The maximum length of a drop line is 6 m. It is possible to make a secondary branch from a drop line.

■ **Total Drop Line Length**

The total drop line length is the total sum length of all the drop lines (but not including the trunk line). Do not exceed the maximum total drop line length (even when the length of each individual drop line is 6 m or less). The standard for the total drop line length varies with the baud rate as shown in the previous table.

■ **Configuration Example**

The following configuration example shows the maximum length of the Network, the drop line lengths, and the total drop line length.

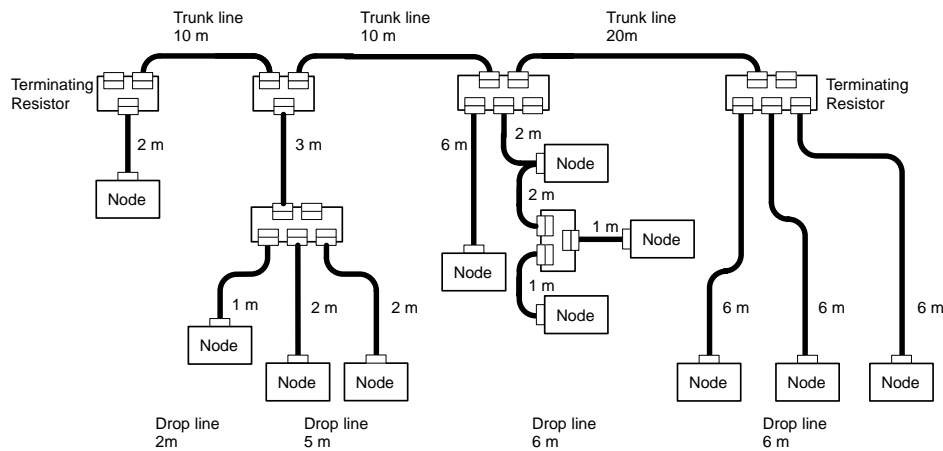

Maximum Network Length

The longest distance between nodes is 48 m, and the distance between the two Terminating Resistors is 40 m. The maximum Network length is therefore 48 m.

Drop Line Length

There are four branch points in the trunk line. The length of each drop line is shown in the diagram. The maximum drop line length is 6 m.

Total Drop Line Length

The sum of all the drop lines is 40 m.

2-2-2 Locating Terminating Resistors

Be sure to connect the Terminating Resistors at both ends of the trunk line to reduce signal reflection and stabilize communications.

When there is a T-branch Tap 6 m or less from the end of the trunk line (or the node):

A Terminating Resistor attached to a T-branch Tap can easily be mounted without taking up much space.

When there is not a T-branch Tap 6 meters or less from the end of the trunk line (or the node):

A Terminating Resistor must be connected before that point. Either a T-branch Tap mounted to a Terminating Resistor or a terminal block with Terminating Resistor can be used. In this case, be sure to make the cable length 1 m or less from the node to the Terminating Resistor.



2-3 Communications Power Supply

2-3-1 Locating the Communications Power Supply

■ Basic Concept

- The communications power supply must be 24 V DC.
- Make sure that the power is supplied from the trunk line.
- When providing power to several nodes from one power supply, if possible try to locate the nodes in both directions from the power supply.
- Provide power through Power Supply Taps. It is, however, possible to use T-branch Taps instead when there is one communications power supply in the system and the total current consumption is less than 5 A.
- The power supply capacity for cables is restricted to 8 A for Thick Cables and 3 A for Thin Cables.
- A single Network is usually supplied by one power supply. It is, however, possible to have more than one power supply when power supply specifications cannot be met with a single power supply. (See 2-3-4 Step 3: *Splitting the System into Multiple Power Supplies.*)
- Fully consider the power supply capacity allowance in the design.
- If the power supply is switched OFF during the operation of the Network, there may be a malfunction in the nodes.
- The current capacity of the drop line varies according to its length. The longer the drop line, the lower its maximum capacity becomes. This is the same whether the cable is thick or thin. Calculate the current capacity passing through the drop line I (the total current consumption at the drop line) using the following formula.

$$I = 4.57/L$$

I: Permissible current (A)
L: Length of the drop line (m)

Flowchart

Use the flowchart below to determine the communications power supply on the trunk line. Satisfy the conditions for each drop line on page 2-6.

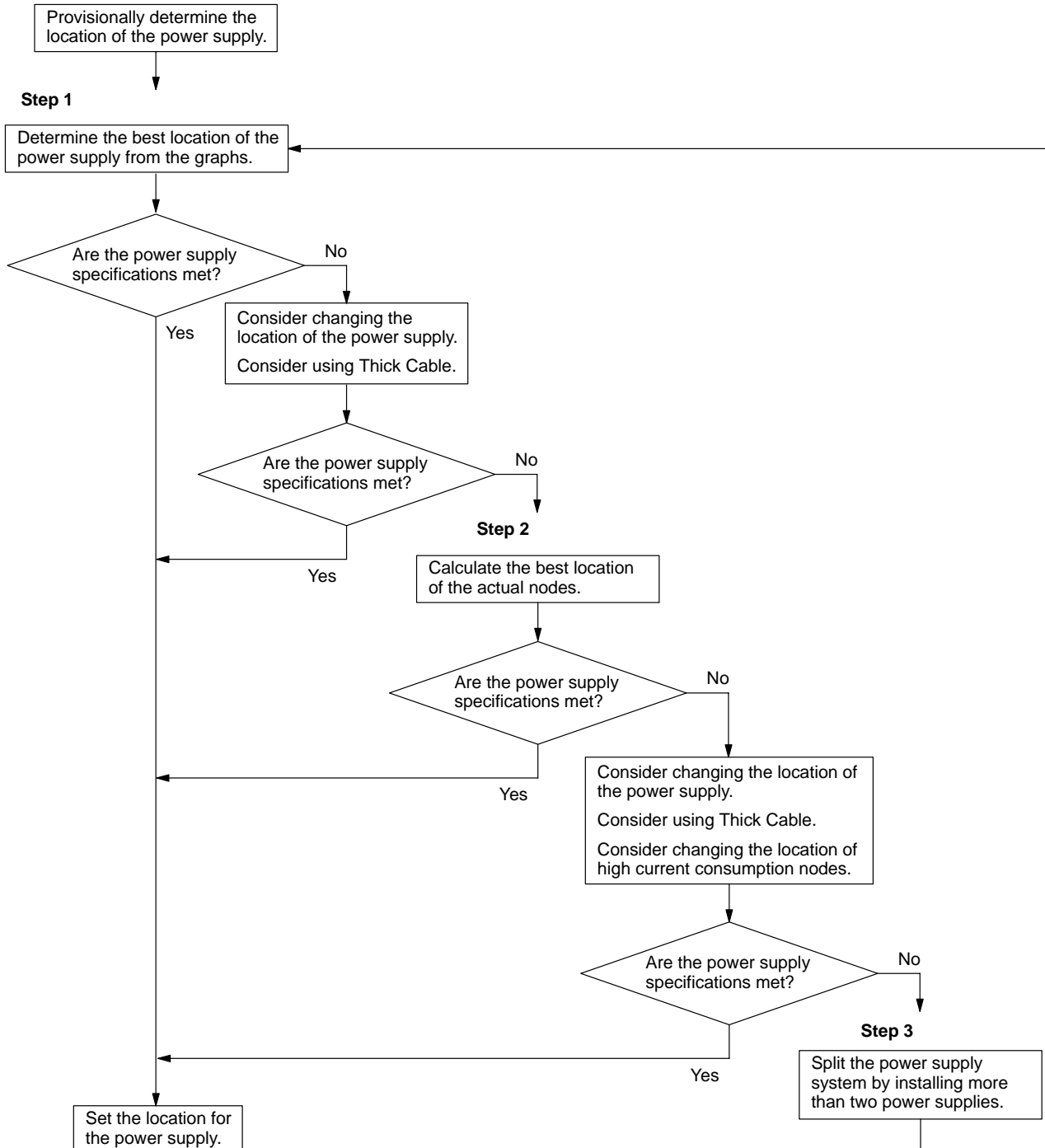

Power Supply Location Patterns

The power supply can be located in the configurations shown below. Basically, select from the configurations 1 and 2.

Consider using configuration 3 when power supply specifications cannot be met by configurations 1 and 2. It is possible to use configuration 4 for a duplex power supply.

1 Locating the Nodes on Both Sides of the Power Supply

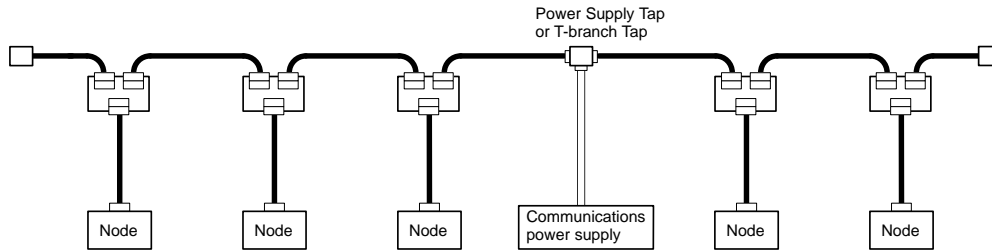

2 Locating the Nodes on One Side of the Power Supply

Note Configuration 1 is recommended for a single power supply to several nodes.

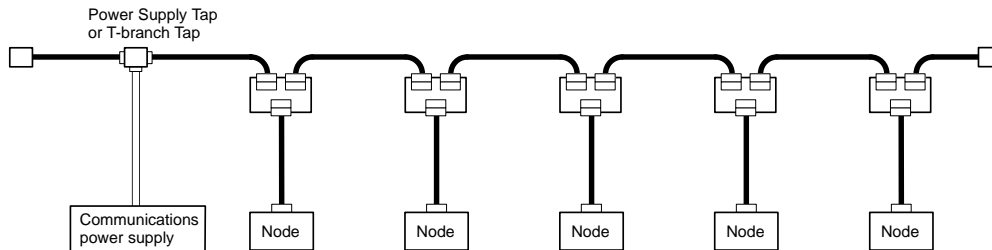

3 Splitting the Power Supply System with Multiple Power Supplies

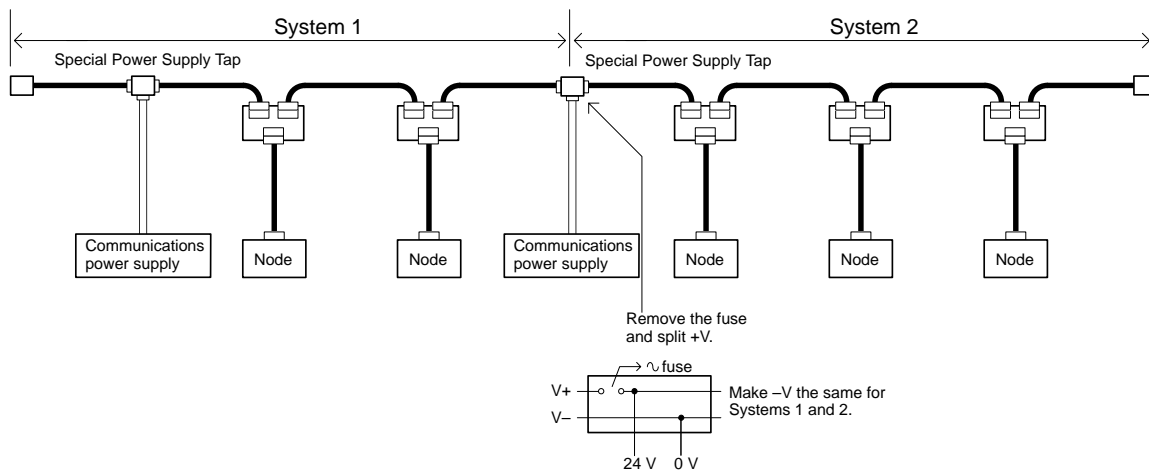

4 Duplex Power Supply with Multiple Power Supplies

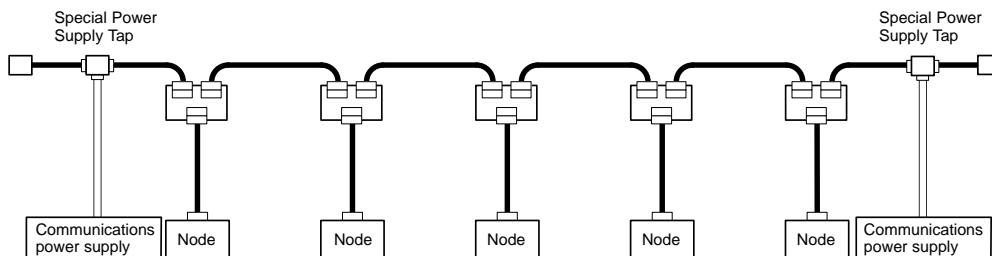

Note 1. If power supply specifications cannot be met with a single power supply when the current capacity of the Thick Cable exceeds 8 A even after the power supply location is modified, use more than one communications power supply.

Note 2. In configuration 1, the power can be supplied in two directions to the trunk line as long as the current capacity of each is 8 A or less when using Thick Cable, i.e., it is possible to have a configuration with a total maximum current capacity of up to 16 A.

Note 3. Consider changing to Thick Cable to meet specifications if the current capacity of the Thin Cable exceeds 3 A when using Thin Cable for the trunk line.

■ **Setting the Power Supply Location**

Determine whether or not the current can be supplied normally by finding the current capacity required by each node and the voltage drop in the cables to be used to provide power. Calculate the values below in advance.

- The current capacity required by each node
- The distance between the power supply and each node

The current capacity of the 3G3MV-PDRT1-SINV1 DeviceNet Communications Unit is approximately 20 mA.

■ **Calculating the Power Supply Location**

There are two methods to find the best location of the communications power supply on the trunk line.

- Simple calculation from a graph
- Calculation by formula (Calculating the voltage drop from resistance and current consumption of the communications cables).

Each drop line must satisfy the equation on page 2-6, which represents the relationship between the drop line length and the current capacity for the drop line.

Note 1. From the graph, a hypothetical power supply location can be determined if the conditions calculated in the graph are met by estimating the worst configuration (that has the maximum voltage drop as shown in the diagram below).

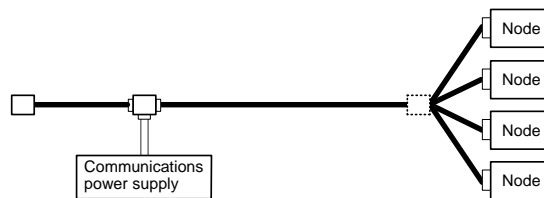

Note 2. Even if the power supply specifications cannot be met using the graph, the conditions can be met and a hypothetical power supply location determined by using the formula.

Note 3. When the communications power supply and the internal circuit supply are the same, use the formula to calculate a hypothetical power supply location because it cannot be determined by using the graph.

2-3-2 Step 1: Determining the Best Location for the Power Supply from a Graph

A voltage drop occurs when a current flows through a communications cable. The longer the communications cable and the larger the current, the greater the voltage drop. The communications power supply at each node must be 11 V DC or more. To ensure the correct power supply, the relationship is plotted as shown in the following graph to find the maximum current that satisfies the voltage of the communications power supply at different trunk line lengths even if there is a voltage drop due to cable resistance.

■ Thick Cable

Distance (m)	0	25	50	100	150	200	250	300	350	400	450	500
Max. current (A)	8.00	8.00	5.42	2.93	2.01	1.53	1.23	1.03	0.89	0.78	0.69	0.63

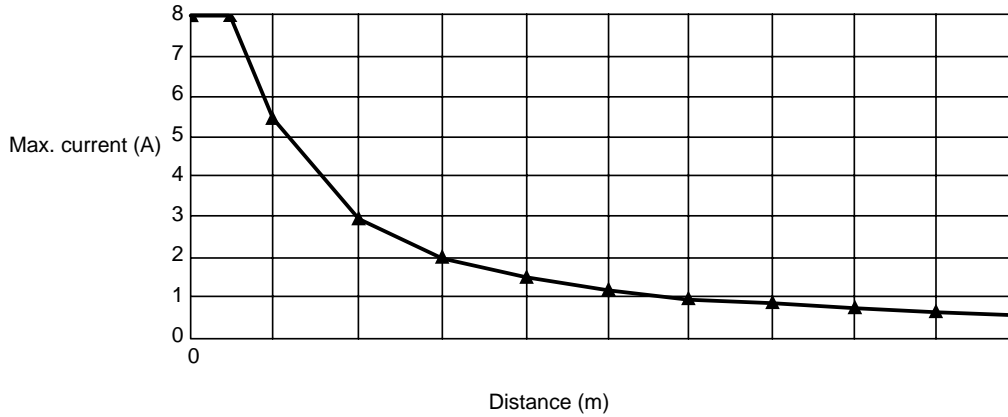

■ Thin Cable

Distance (m)	0	10	20	30	40	50	60	70	80	90	100
Max. current (A)	3.00	3.00	3.00	2.06	1.57	1.26	1.06	0.91	0.80	0.71	0.64

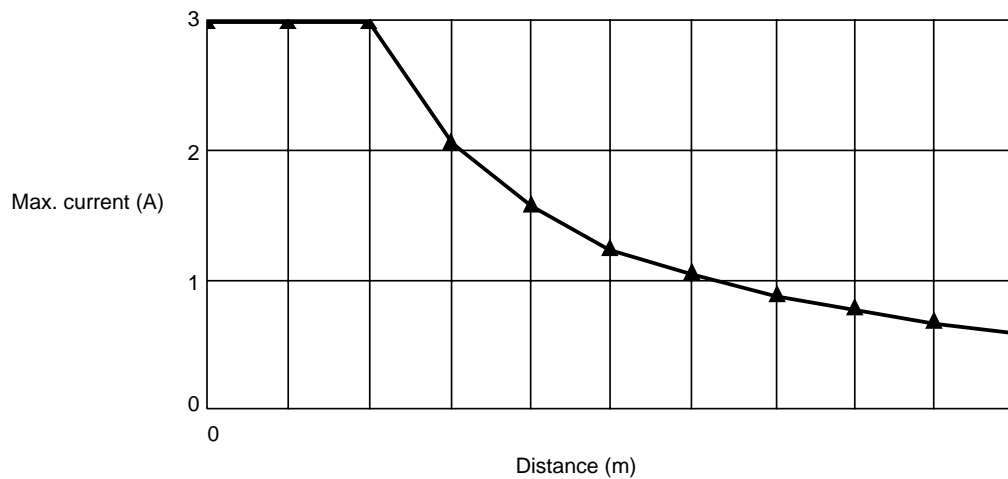

■ Determining the Best Location of the Power Supply from a Graph

Verify the Items 1 to 3 below for each node located in the same direction viewed from the power supply. Therefore, if nodes are located on both sides of the power supply, these items must be verified for all nodes located in each direction.

- 1 Find A, the total current consumption of all the nodes to which communications power is to be supplied.
- 2 Using the graph compute B, the maximum current flow in each cable from the power supply to the end of the trunk line according to the types of cables (Thick Cables or Thin Cables).

3 Compare the values found in steps 1 and 2, above. If the first value (A) is less than the second (B), this shows that power supply specifications are met and power can be supplied to all nodes at any point in the Network.

Note Be sure to refer to the correct graph as the maximum current flow is different for Thick and Thin Cables.

■ Countermeasures

If the second value (B) is less than the first (A), use the following procedure to locate the communications power supply.

- Locate the communications power supply in the center of the Network and the nodes to both sides of it.
- If the nodes are already located at both sides of the power supply, move the power supply in the direction that requires the larger current capacity.
- If Thin Cable is being used, replace it with Thick Cable.

Note If, after following the above procedure, B is still less than A, go to Step 2 and determine the actual position of the nodes by the formula calculation method.

● Calculation Example

The following example shows a Network that requires power to be supplied for 240 m on Thick Cable. The power supply is located in the center of the Network. Because the power supply is in the center, the maximum current will flow both to the left and to the right, enabling the supply of at least twice the maximum current as when the power supply is placed on the end of the Network. The current consumption for individual nodes is as follows:

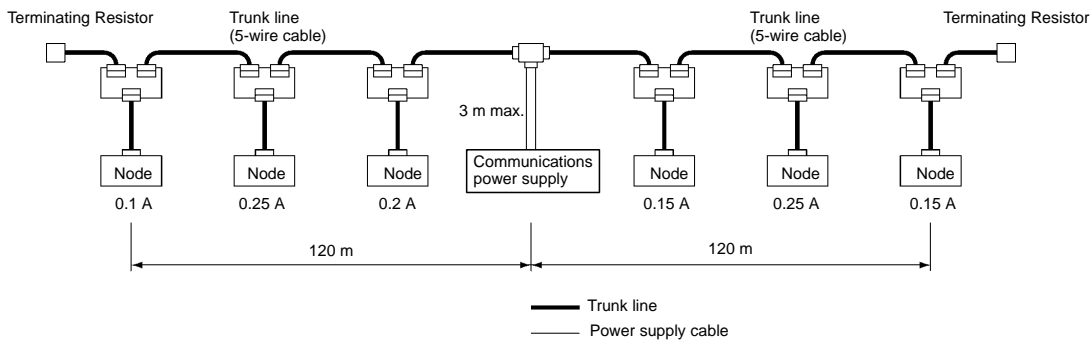

Total power supply length on left = Total power supply length on right = 120 m

Total current consumption on left: $0.1 + 0.25 + 0.2 = 0.55 \text{ A}$

Total current consumption on right: $0.15 + 0.25 + 0.15 = 0.55 \text{ A}$

Maximum current for the left side of the Thick Cable (see previous table) = approx. 2.5 A

Maximum current for the right side of the Thick Cable (see previous table) = approx. 2.5 A
(using straight line approximation between 100 to 150 m)

2-3-3 Step 2: Calculating the Best Location of the Actual Nodes

Go to Step 2 if the best location for the power supply according to the specifications cannot be determined from the graphs. The second method calculates the best location for each actual node and does not estimate the worst possible configuration for the power supply.

Basically, in the DeviceNet Network the permissible maximum voltage drop within the system can be specified at 5 V for a power supply line (+V or -V), by calculating the specifications for the voltage of the communications power supply (24 V DC) and the input voltage of the communications power supply of each device (11 to 25 V DC).

Of the permissible 5-V maximum voltage drop within the system, the permissible voltage drop is 4.65 V in the trunk lines and 0.35 V in the drop lines.

The following formulae are applicable when power is supplied independently for communications and the internal circuit. For details on voltage drop and formulae when the communications power supply and internal circuit power supply are shared, refer to the *DeviceNet Operation Manual*.

■ **Formulae**

Try to calculate the best location for each node using the formula below. If the best location for each node can be determined using the formula, the specifications for the power supply to each node can also be met. Do not exceed the maximum current capacity of the cable (Thick Cable: 8 A and Thin Cable: 3 A).

$$\{(L_1 \times R_C + N_1 \times 0.005) \times I_1\} + \{(L_2 \times R_C + N_2 \times 0.005) \times I_2\} + \dots + \{(L_n \times R_C + N_n \times 0.005) \times I_n\} \leq 4.65 \text{ V}$$

- Li: The distance (m) of the trunk line between the power supply and node i.
- Rc: Maximum cable resistance for approx. 1 m
(Thick Cable: 0.015 Ω/m, Thin Cable: 0.069 Ω/m)
- Ni: The number of T-branch Taps on the trunk line between the power supply and node i.
- Ii: The consumption current required for the communications power supply for node i.
- 0.005 Ω = The contact resistance of the T-branch Taps.

Note If there are nodes on both sides of the power supply, the formula is used to calculate the best location in each direction, and if the conditions are satisfied, then the locations are valid. The conditions are satisfied if the following equations are true. This formula, however, considers only the communications power supply. If using the same power supply for the DeviceNet Communications Unit, calculations must include the Unit power supply specifications.

- Voltage drop (V) on trunk line at left side $\leq 4.65 \text{ V}$
- Voltage drop (V) on trunk line at right side $\leq 4.65 \text{ V}$

● **Calculation Example**

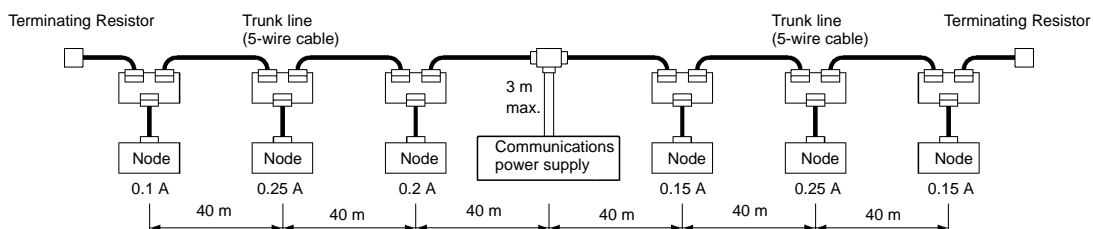

Left Side Equation

Node 1: $(120 \times 0.015 + 3 \times 0.005) \times 0.1 = 0.1815 \text{ (V)}$
 Node 2: $(80 \times 0.015 + 2 \times 0.005) \times 0.25 = 0.3025 \text{ (V)}$
 Node 3: $(40 \times 0.015 + 1 \times 0.005) \times 0.2 = 0.121 \text{ (V)}$
 If $0.1815 + 0.3025 + 0.121 = 0.605 \text{ V} \leq 4.65 \text{ V}$, the conditions are satisfied.

Right Side Calculation

Node 4: $(40 \times 0.015 + 1 \times 0.005) \times 0.15 = 0.09075 \text{ (V)}$

Node 5: $(80 \times 0.015 + 2 \times 0.005) \times 0.25 = 0.3025 \text{ (V)}$

Node 6: $(120 \times 0.015 + 3 \times 0.005) \times 0.15 = 0.27225 \text{ (V)}$

If $0.09075 + 0.3025 + 0.27225 = 0.6655 \text{ V} \leq 4.65 \text{ V}$, the conditions are satisfied.

2-3-4 Step 3: Splitting the System into Multiple Power Supplies

Go to Step 3 if the best location for the nodes cannot be calculated from the formulae. In the third step, there are multiple power supplies and the power supply system is split.

■ Splitting the Power Supply System

- Be sure to use a Power Supply Tap for each power supply when the Network is supplied by two or more power supplies.
- Remove the fuses in the Power Supply Tap to split the power supply system.

Once the power supply system is split, return to Step 1 or 2, and determine the best location of the nodes in each system.

■ Power Supply Tap Configuration

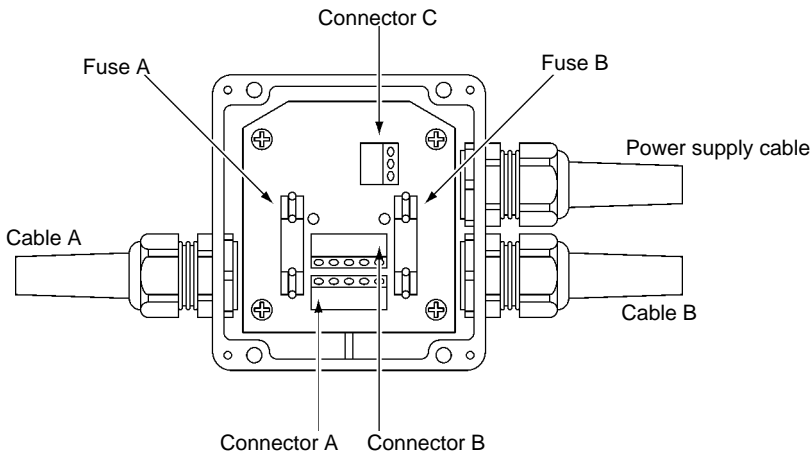

Model	1485T-R2T5-T5
Specification	Power supply tap (with a grounding terminal and reverse current prevention function)
Manufacturer	Allen-Bradley

■ Internal Circuitry of the Power Supply Tap

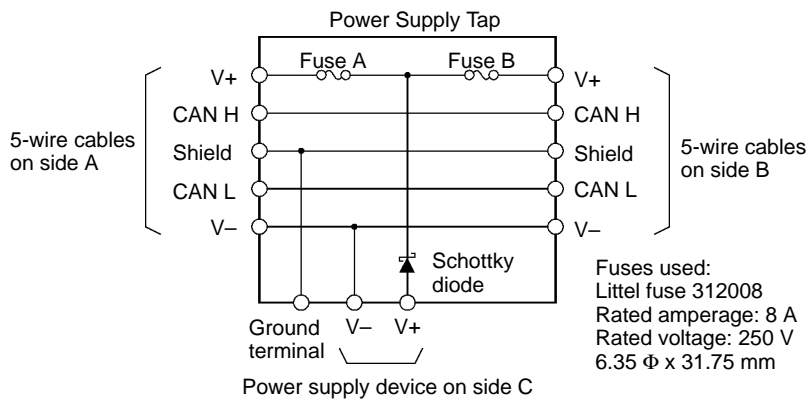

2-3-5 Dual Power Supplies

Because diodes are contained in Power Supply Taps, these taps can be used to construct a dual power supply system in the Network. Dual power supply differs from parallel operation of power supplies, so the following restrictions apply.

■ Restrictions

Dual power supply is basically used to ensure backup power supply, not parallel operation of power supplies. Therefore, each power supply to be used must meet the power allocation specifications (i.e., must satisfy steps 1 and 2).

2-4 Communications Line Noise Prevention

2-4-1 Communications Line Noise

The communications line sends and receives high-speed pulse signals, and checks whether the data is correct by checking the sequence of the signals. If the amount of noise on the communications line is too great, the interference will alter the communications signal data, and communications will be impossible. Communications lines are more sensitive and require higher speeds than normal I/O lines, so be sure that noise does not interfere with communications. Use the preventative noise countermeasures described here when configuring the system to ensure smooth system start up.

2-4-2 Grounding the Network

■ Grounding the Network

The DeviceNet Network must be grounded at only one location so that a ground loop is not created. The ground should also be connected as close as possible to the center of the Network. Connect the cable shield to the ground terminal on the communications power supply and then connect to a ground of 100 Ω max., as shown in the following diagram.

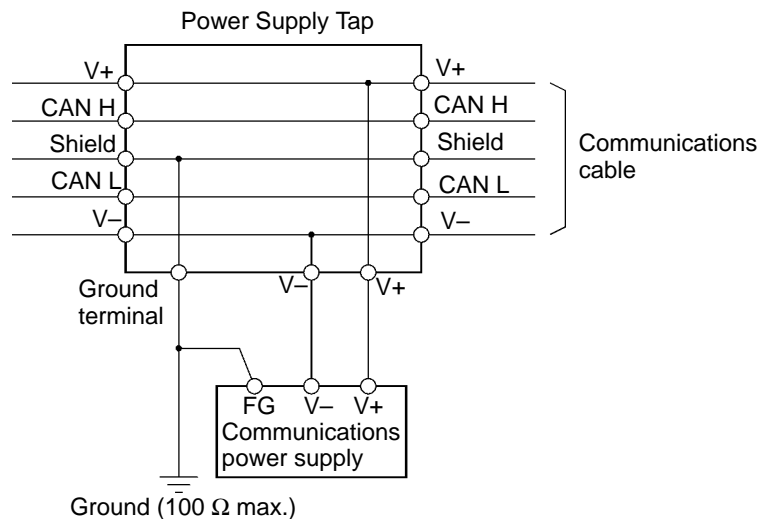

If more than one communications power supply is connected to the same Network, ground only the one nearest the center of the Network. Do not connect the shield wire at the other power supplies.

Note 1. Always ground the communications cable shield at one and only one location in the Network.

Note 2. Always ground to 100 Ω or less.

Note 3. Always use a separate ground. Never use the same ground as for Inverters or other drive system devices.

■ Grounding the DeviceNet Communications Unit

The DeviceNet Communications Unit should be grounded according to DeviceNet recommendations installing a noise filter as shown in the following diagram. The ground is normally wired to the ground terminal (⊖).

Note If the cable grounded to the Inverter is not sufficient and is receiving noise interference, disconnect the grounding cable.

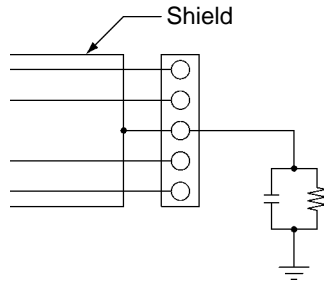

2-4-3 Communications Power Supply Noise Prevention

The communications power supply is the most important power supply in a DeviceNet Network. The following measures will prevent noise in the communications power supply.

- Use the recommended power supply (S82H/S82J) for communications.
- Use an independent power supply for communications.
- Make sure to install a noise filter on the primary AC input side of the communications power supply.
- Always use a control system power supply for the primary AC side of the communications power supply that is not shared with power devices, such as Inverters or motors.

If noise interference remains in cables for which noise countermeasures have been implemented, the following countermeasures may be effective.

• Communications Cable Shielding

Suspend the communications cable shielding wire without grounding it. This will filter the noise that flows from the ground to the communications cable and will filter the noise current that flows in the shielding wire.

• Communications Power Supply

Suspend the communications power supply without grounding it. This will also filter the noise that flows from the communications power supply ground to the communications cable or the noise current that flows in the shielding wire. The switching power supply is usually connected to the case and the capacitor as shown below. The ground (FG) terminal must be suspended and the control panel for the power supply itself must be insulated.

Switching Power Supply Configuration

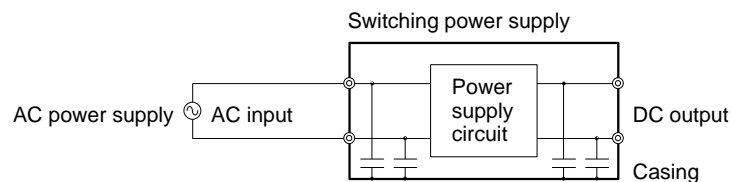

Suspending the Communications Power Supply

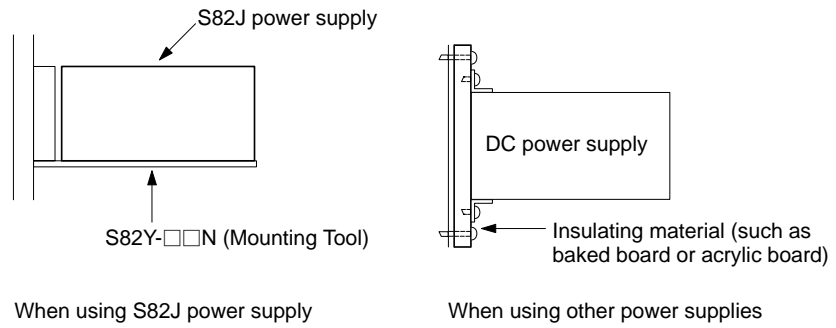

2-4-4 Noise Prevention Wiring

To prevent inductive noise, do not wire the communications line, SYSMAC power lines, and other power lines near to each other. Keep the power lines for Inverters, motors, regulators, and contactors, the communications lines, and the SYSMAC power lines separated from each other by at least 300 mm. Also, provide separate conduits or ducts for the communications lines and power lines.

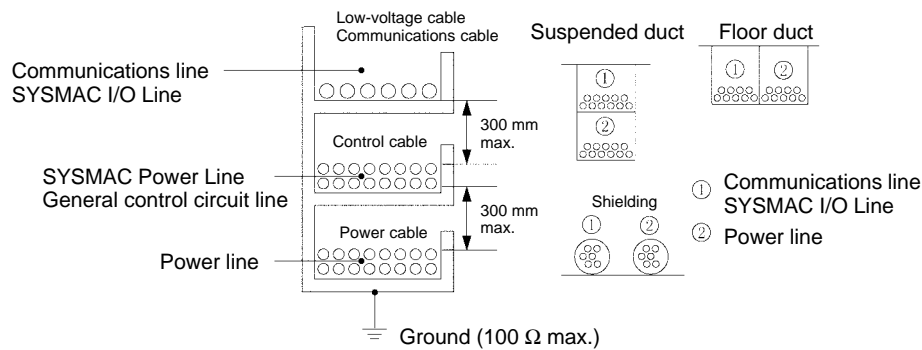

- Do not install communications lines and SYSMAC power lines onto the control panel on which high-voltage devices are mounted.
- Because noise currents flow through metallic equipment (such as casings), the communications cables should be placed as far away from metallic equipment as possible.
- Ground the shielding wire on the communications cable at one point.
- If the same ground is used for the communications cables and communications power supply, there is a possibility that noise may be transmitted through the ground line to the communications line. In order to avoid this, be sure that the power line ground and the grounds for the communications cables and the communications power supply are located as far from each other as possible.

! Caution Connect the communications signal lines (V+, CANH, shield, CANL, and V-) so that they do not come into contact with each other.

If noise is generated, check the wiring.

- Communications may be performed even if the V+ and CANH, or V- and CANL, are in contact with each other, but differential operation will not be performed, reducing resistance to noise.
- If the shield wire comes into contact with any of the signal lines, a high level of noise will be superimposed on the line, reducing resistance to noise.

2-4-5 Noise Prevention for Peripheral Devices

- Install surge suppressors on devices that generate noise, particularly devices that have an inductive component such as motors, transformers, solenoids, and magnetic coils.

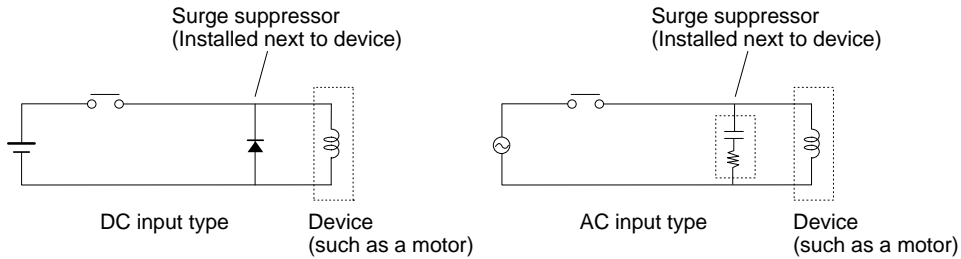

- If a surge suppressor does not fit on the device, installing a ferrite core directly next to the device's contactors, such as a contactor may be effective.

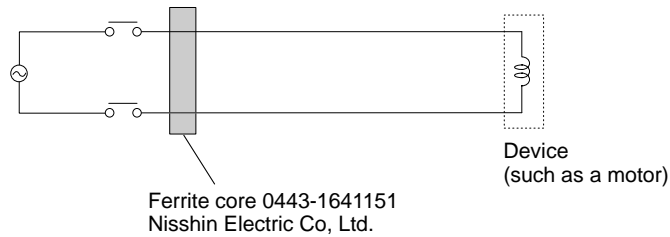

- Insert a line filter on the primary side of the communications power supply.
- When there are two or more communications power supplies, the communications power cables can be grounded by simply connecting a single Power Supply Tap near the center of the communications cable. Do not ground shielding wire at more than one place.

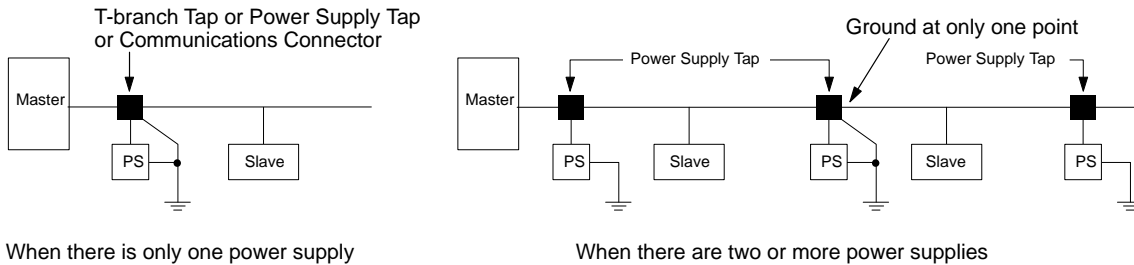

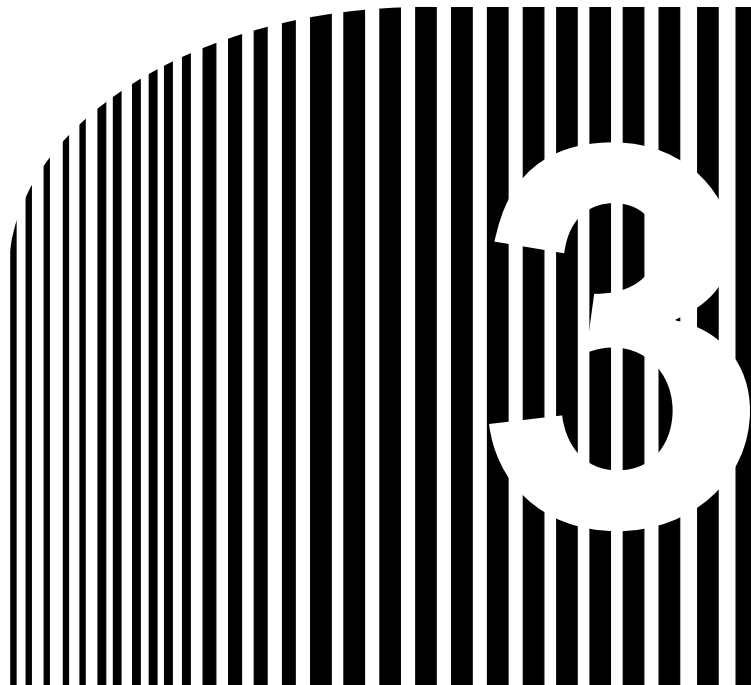

Chapter 3

• Setup and Wiring •

- 3-1 Nomenclature and Settings
- 3-2 Installation and Wiring

3-1 Nomenclature and Settings

3-1-1 Names of Parts

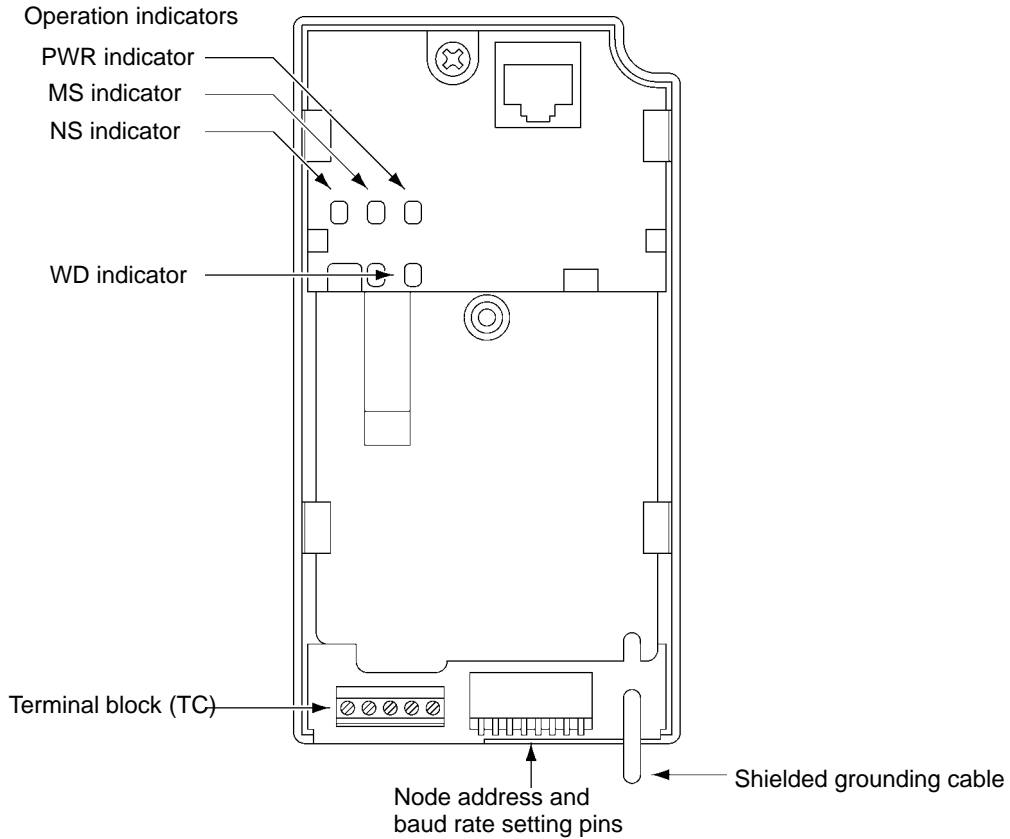

3-1-2 Terminal Block

The following table provides details of the terminal block connected to the communications line.

Display	Sticker color	Code	Cable color	Details
1	Black	V-	Black	Communications power supply ground.
2	Blue	CAN L	Blue	Communications data low side.
3	---	SG	(Shield)	Shield connection.
4	White	CAN H	White	Communications data high side.
5	Red	V+	Red	Communications power supply, 24 V DC.

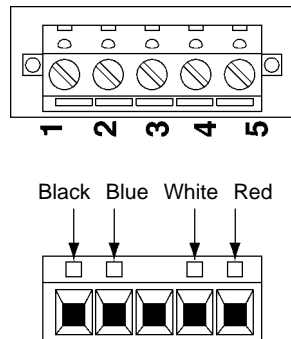

3-1-3 Operation Indicators

The DeviceNet Communications Unit has 4 operation indicators that show the status of the power and communications as described in the following table.

Indicator	Display		Meaning
	Color	Status	
PWR	Green	Lit	Power is being supplied from the Inverter to the Unit.
	---	Not lit	Power is not being supplied from the Inverter. The Unit is not connected properly and power is not being supplied to it.
MS	Green	Lit	The Unit is operating normally.
		Flashing	Initial settings or necessary preparations for communications are incomplete.
	Red	Lit	A fatal error (hardware error) has occurred in the Unit.
		Flashing	A non-fatal error, such as a switch setting error, has occurred.
	---	Not lit	Power is not being supplied from the Inverter. The Unit is not connected properly and power is not being supplied to it.
NS	Green	Lit	The DeviceNet Network is operating normally. (Communications connection established.)
		Flashing	The Network is normal, but the communications connection with the Master Unit is not established.
	Red	Lit	A fatal communications error has occurred. A DeviceNet communications error was detected caused by node address duplication or Bus OFF. (These errors make communications impossible.)
		Flashing	A non-fatal communications error has occurred due to communications timeout.
	---	Not lit	A DeviceNet Network error has occurred. For example, the Network does not exist, power is not supplied to the Unit, or the baud rates do not match.
WD	Green	Flashing	The CPU Unit of the Unit is operating normally.
	Red	Lit	The CPU Unit of the Unit is not ready or the CPU Unit has malfunctioned.
	---	Not lit	Power is not being supplied from the Inverter. The Unit is not connected properly and power is not being supplied to it.

Note When both of the baud rate setting pins DR0 and DR1 are set to ON, both the MS and NS will be lit in red.

3-1-4 Baud Rate and Node Address Settings

In a DeviceNet Network, the baud rate can be set to 500 Kbps, 250 Kbps, or 125 Kbps. To manage Master/Slave communications, numbers are assigned as node addresses.

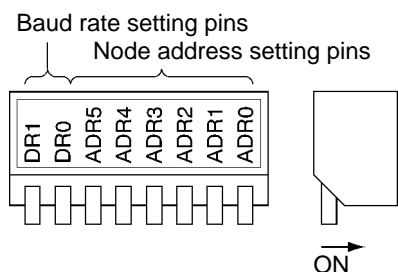

Note Default settings are all OFF.

■ Baud Rate Setting Pins









Pin	500 Kbps	250 Kbps	125 Kbps
DR1	ON	OFF	OFF
DR0	OFF	ON	OFF

■ Node Address Setting Pins

Pin	Node Address																		
	0	1	2	3	4	5	6	7	8	9	10	11	12	13	14	15	to	63	
ADR5	OFF	OFF	OFF	OFF	OFF	OFF	OFF	OFF	OFF	OFF	OFF	OFF	OFF	OFF	OFF	OFF	OFF	to	ON
ADR4	OFF	OFF	OFF	OFF	OFF	OFF	OFF	OFF	OFF	OFF	OFF	OFF	OFF	OFF	OFF	OFF	OFF	to	ON
ADR3	OFF	OFF	OFF	OFF	OFF	OFF	OFF	OFF	ON	ON	ON	ON	ON	ON	ON	ON	ON	to	ON
ADR2	OFF	OFF	OFF	OFF	ON	ON	ON	ON	OFF	OFF	OFF	OFF	ON	ON	ON	ON	ON	to	ON
ADR1	OFF	OFF	ON	ON	OFF	OFF	ON	ON	OFF	OFF	ON	ON	OFF	OFF	ON	ON	ON	to	ON
ADR0	OFF	ON	OFF	ON	OFF	ON	OFF	ON	OFF	ON	OFF	ON	OFF	ON	OFF	ON	ON	to	ON

- Note 1.** The same node address cannot be used for more than one Slave connected to the communications line.
- Note 2.** Remote I/O allocations in the CPU Unit are affected by the node addresses, so make sure that the remote I/O allocations do not overlap before setting a node address. Refer to *Chapter 4 DeviceNet System Startup*.

3-2 Installation and Wiring

-  **WARNING** Do not touch the conductive parts such as internal PCBs or terminal blocks while power is being supplied. Doing so may result in electrical shock.
-  **WARNING** Turn ON the input power supply only after mounting the front cover, terminal covers, bottom cover, Operator, and optional items. Leave them mounted in place while power is being supplied. Not doing so may result in electrical shock, malfunction, or damage to the product.
-  **WARNING** Wiring, maintenance, or inspection must be performed by authorized personnel. Not doing so may result in electrical shock or fire.
-  **WARNING** Wiring, maintenance, or inspection must be performed after turning OFF the power supply, confirming that the CHARGE indicator (or status indicators) is OFF, and after waiting for the time specified on the Inverter front cover. Not doing so may result in electrical shock.
-  **WARNING** Do not damage, pull on, apply stress to, place heavy objects on, or pinch the cables. Doing so may result in electrical shock, operation stoppage, or burning.
-  **WARNING** Do not attempt to disassemble or repair the Unit. Doing either of these may result in electrical shock, injury, or damage to the product.
-  **Caution** Do not store, install, or operate the product in the following places. Doing so may result in electrical shock, fire or damage to the product.
- Locations subject to direct sunlight.
 - Locations subject to temperatures or humidity outside the range specified in the specifications.
 - Locations subject to condensation as the result of severe changes in temperature.
 - Locations subject to corrosive or flammable gases.
 - Locations subject to exposure to combustibles.
 - Locations subject to dust (especially iron dust) or salts.
 - Locations subject to exposure to water, oil, or chemicals.
 - Locations subject to shock or vibration.
-  **Caution** Do not allow foreign objects to enter inside the product. Doing so may result in fire or malfunction.
-  **Caution** Do not apply any strong impact. Doing so may result in damage to the product or malfunction.

- ⚠ **Caution** Be sure to wire correctly and securely. Not doing so may result in injury or damage to the product.
- ⚠ **Caution** Be sure to firmly tighten the screws on the terminal block. Not doing so may result in fire, injury, or damage to the product.
- ⚠ **Caution** Carefully handle the product because it uses semiconductor elements. Careless handling may result in malfunction.
- ⚠ **Caution** Take appropriate and sufficient countermeasures when installing systems in the following locations. Not doing so may result in equipment damage.
 - Locations subject to static electricity or other forms of noise.
 - Locations subject to strong electromagnetic fields and magnetic fields.
 - Locations subject to possible exposure to radioactivity.
 - Locations close to power supplies.

3-2-1 DeviceNet Communications Unit Installation

- ⚠ **Caution** Before installing and wiring an Optional Unit, always turn OFF the power to the SYSDRIVE 3G3MV Inverter and wait for the CHARGE indicator to turn OFF.

■ Mounting Procedure

1. Turn OFF the main circuit power supply for the Inverter, wait for at least one minute from the time the LED indicator or the CHARGE indicator goes out, and remove the front cover of the Inverter along with the Operator.

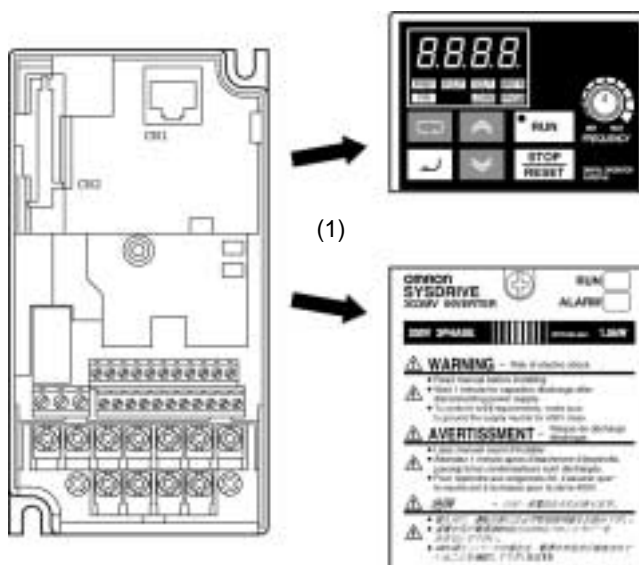

2. Wire the main circuit terminals and control circuit terminals of the Inverter. (When the Communications Unit is mounted, the terminal block of the Inverter will be covered. Therefore, be sure to complete wiring for the Inverter terminals first.)

- When the Operator of the Inverter is removed, it will be possible to see a block secured at three places underneath. Using pliers or another appropriate tool, loosen the fixings, and remove the block. The connector for Optional Unit connections will become visible. At this point, ensure that dirt or foreign objects do not enter the connector.

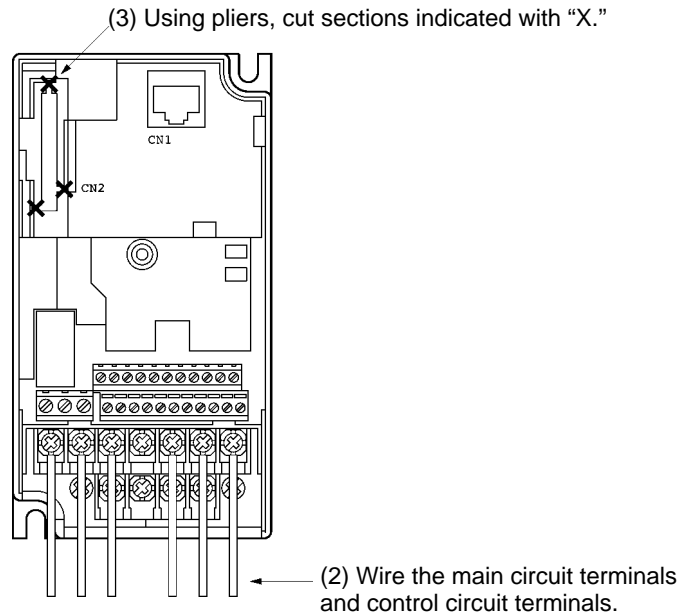

- Mount the mounting base (included as an accessory) onto the screw-holes originally used for holding the Operator and the terminal cover to the body of the Inverter, and using the screws provided as accessories, secure the mounting base.

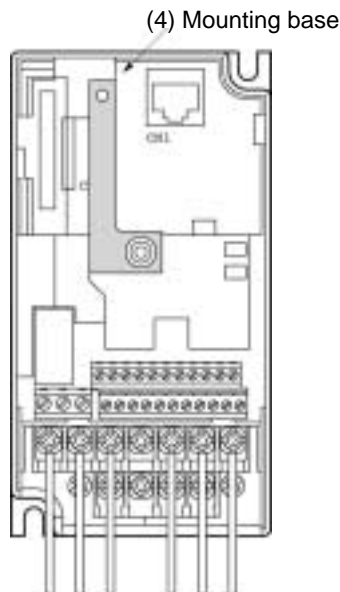

5. On the opposite side of the DeviceNet Communications Unit, there is a ground terminal that is connected to the shielded wire for the Communications Cable. Connect this ground terminal to the FG terminal of the Inverter.

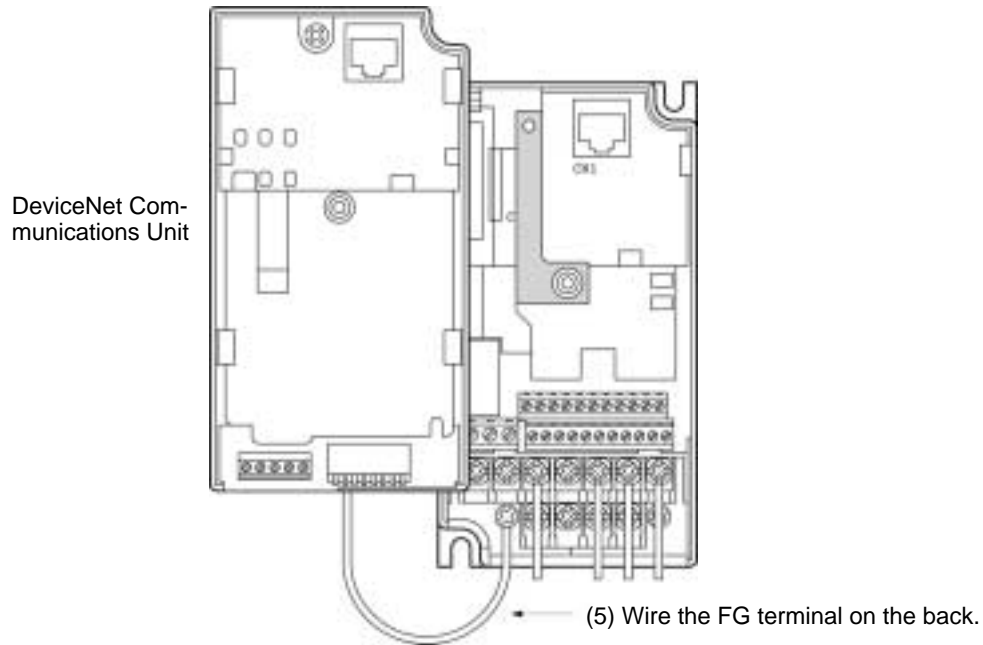

6. After aligning the positions of the DeviceNet Communications Unit connector and the Inverter connector, push the frames of the Inverter and the Unit together until they click.
7. Tighten the fixing screws on the upper part of the DeviceNet Communications Unit, to the mounting base attached in step 4.
8. Perform wiring for the communications cables, and perform the communications settings (baud rate and node address).
9. Attach the Operator and the terminal cover to the front side of the DeviceNet Communications Unit, and secure them by tightening the screw in the center.

3-2-2 Communications Cable Wiring

■ Connecting Communications Cables

This section explains how to prepare and connect the communications cables to connectors for the DeviceNet Network.

Use the following procedure to prepare and connect the communications cables to the connectors.

Note For connecting of the DeviceNet Communications Unit of the Inverter, use DCA1-5C10 Thin Cables.

Thick Cables cannot be used for this kind of wiring because of the terminal block dimensions.

1. Remove about 30 mm of the cable covering, being careful not to damage the shield weaving underneath. Do not remove more than about 30 mm; removing too much of the covering can result in short circuits.

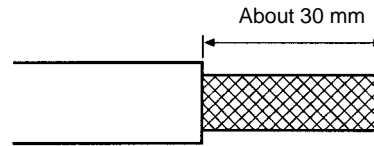

2. Carefully peel back the weaving to reveal the signal lines, power lines, and the shielding wire. The shielding wire will be loose on the outside of the other lines, but it is harder than the weaving.

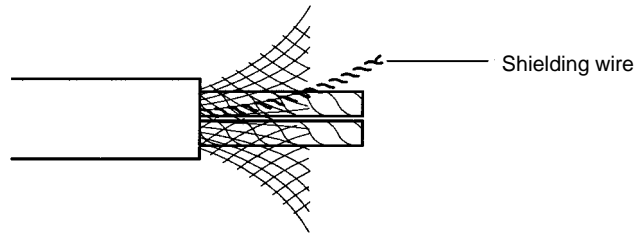

3. Remove the exposed weaving and the aluminum tape from the signal and power lines. Strip the covering from the signal and power lines to the proper length for the crimp terminals. Twist together the wires of each of the signal and power lines.

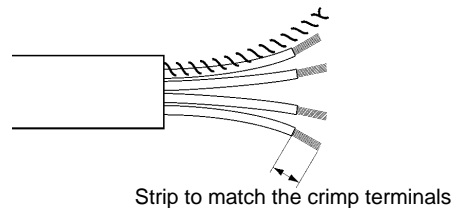

■ **DeviceNet Communications Unit Crimp Terminal**

To further improve the reliability and ease of wiring, use the following straight crimp terminal when wiring the communications cable to the terminal block of the DeviceNet Communications Unit.

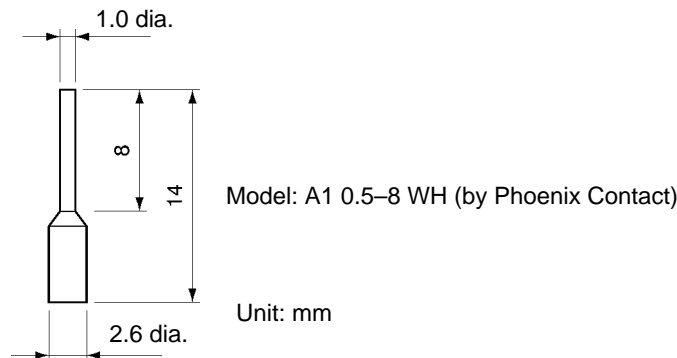

■ **DeviceNet Communications Unit Terminal Block Wiring Procedure**

1. Loosen the terminal screws using a thin flat-blade screwdriver.
2. Insert the wires from underneath the terminal block.

3. Tighten the terminal screws securely to a torque of 0.22 to 0.25 N · m.

Note 1. Separate the DeviceNet communications cables from the main circuit wiring and other power lines.

Note 2. Do not solder the ends of the electric wires. Doing so may cause contact failure.

Note 3. If straight crimp terminals are not used, strip the electrical wires to a length of 5.5 mm.

Note 4. Do not tighten the screws to a torque exceeding 0.22 to 0.25 N · m. Doing so may damage the terminal block. If the screws are too loose, however, malfunctions or short circuits may result.

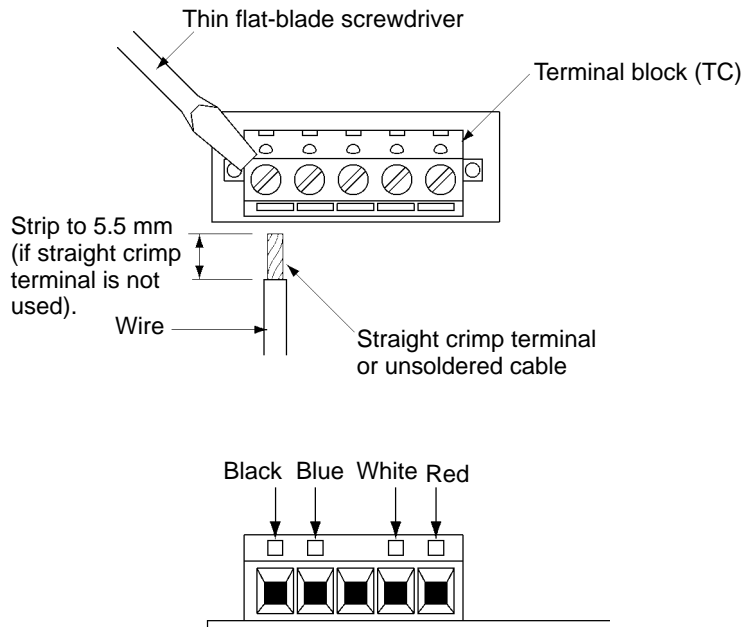

■ Connecting Communications Cables to T-branch Taps

For connecting the DeviceNet Communications Unit, use DCA1-5C10 Thin Cables and branch them from the T-branch Tap. This is done for reasons of terminal block dimensions and easy maintenance.

Note 1. Thick Cables cannot be used for this wiring.

Note 2. As for multi-drop wiring, use Thin Cables for direct insertion.

This section shows how to connect a communications cable with a connector attached to a T-branch Tap. There are two kinds of T-branch Taps, one makes a single branch and the other makes three branches, but the cable connections are the same for both.

The connectors indicated by asterisks in the following diagrams have the least resistance and these connectors should be used for the trunk line connections. When using a T-branch Tap on a drop line, connect the longest drop line to these connectors.

● DCN1-1C T-branch Tap

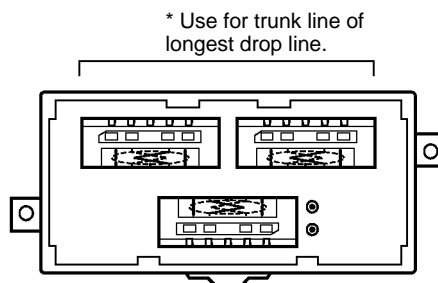

● DCN1-3C T-branch Tap

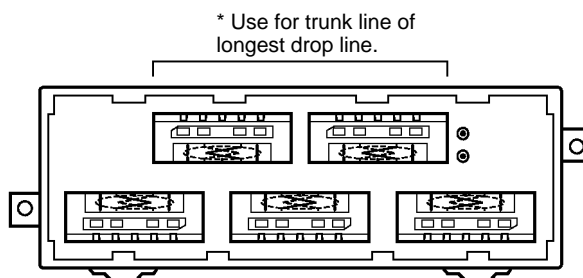

● T-branch Tap Connectors

The required number of connectors (on cable side) for T-branch Taps are supplied with the product.

Name	COMBICON Plug with Screw Flange
Model	MSTBP 2515-STF-5.08 AB AU SO
Manufacturer	Phoenix Contact

Align the cable connector with the socket on the T-branch Tap as shown in the following diagram and fully insert the connector into the socket. Tighten the set screws to secure the connection. Tighten the screws to a torque of 0.3 N·m.

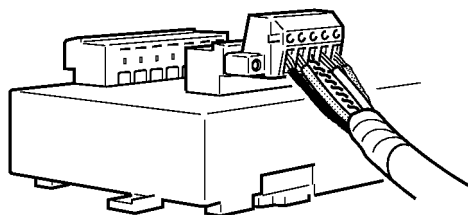

Note To avoid damaging the cable or breaking wires, do not pull on the cable or bend it too sharply when connecting it to the T-branch Tap. Also, never place heavy objects on top of the cable.

■ **Connecting Terminating Resistors**

Terminating resistors must be connected at each end of the trunk line. Use the methods described here to connect the Terminating Resistors.

● **T-branch Tap Terminating Resistor**

A Terminating Resistor is included with the T-branch Tap. Insert the Terminating Resistor into the T-branch Tap as shown in the following diagram. The Terminating Resistor can face in either direction.

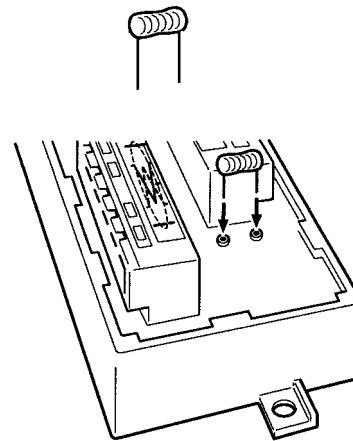

● **Terminal-block Terminating Resistor**

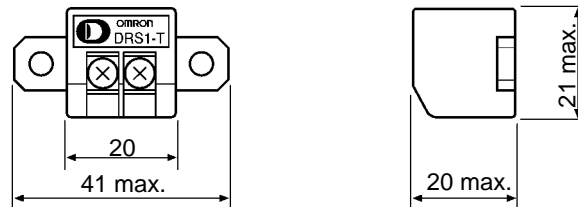

A Terminating Resistor is built into the Terminal-block Terminating Resistor. To connect the cable to the Terminating Resistor, attach standard M3 crimp terminals to the signal wires and securely screw the terminals to the Terminal-block Terminating Resistor. Tighten to a torque of 0.5 N · m.



Note To avoid damaging the cable or breaking wires, do not pull on the cable or bend it too sharply when connecting it to the terminal block. Also, never place heavy objects on top of the cable.

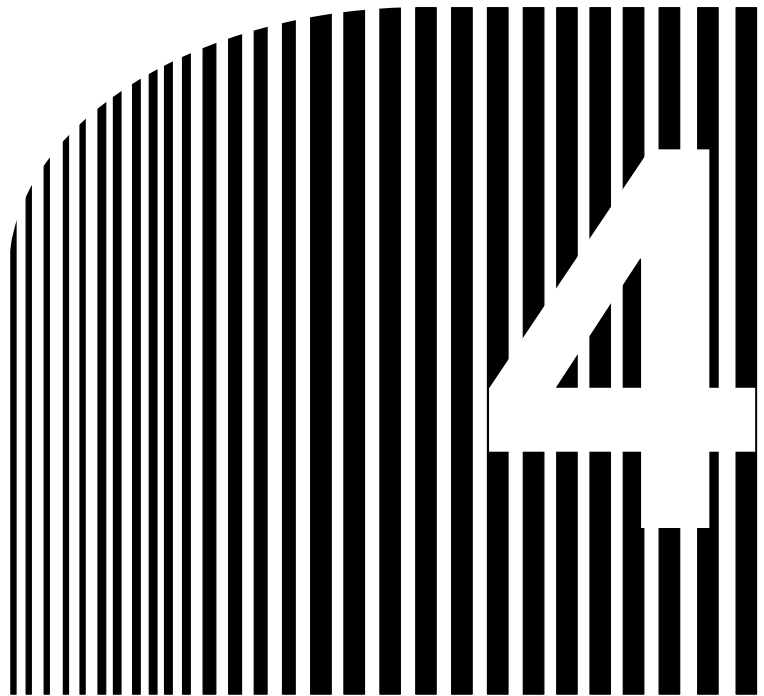

Chapter 4

• DeviceNet System Startup •

- 4-1 SYSMAC Word Allocations and Scan List
- 4-2 SYSDRIVE 3G3MV Settings
- 4-3 Startup Procedure

4-1 SYSMAC Word Allocations and Scan List

In a DeviceNet Network, remote I/O and message communications can be used simultaneously. This section describes remote I/O communications, particularly the memory words allocated in the SYSMAC PC that correspond to the remote I/O of the Slaves.

4-1-1 Overview and Restrictions of Word Allocations

■ Fixed Allocation

With fixed allocation, memory is allocated according to the default word allocations in the DeviceNet Master Unit. Basically, 1 input word and 1 output word is allocated to each node. The word allocation default settings of the Master Unit are based on the assumption that one node should occupy one input word and one output word. Output words will be allocated even to Units that are used only for input. For Units that require two input words or two output words, the node address to which the second word would normally be allocated cannot be set. If it is set, the word allocations will overlap.

● Allocation Areas for CS1W-DRM21 or CJ1W-DRM21 Master Units

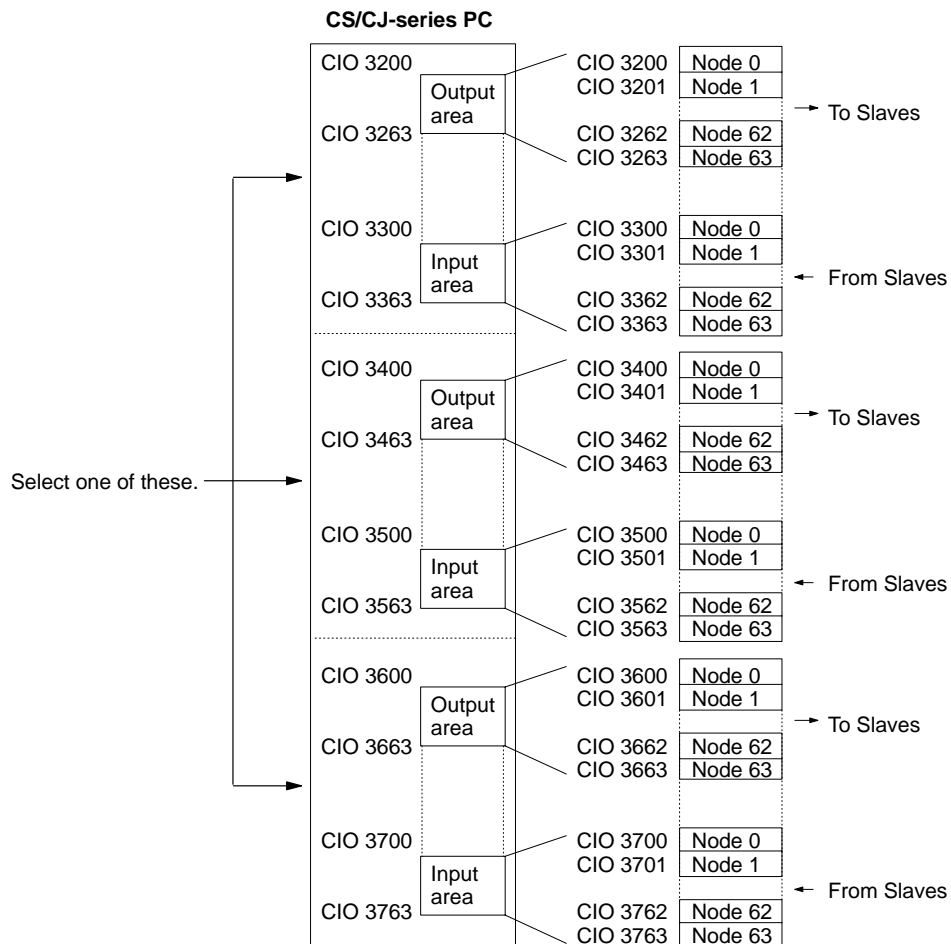

● Allocation Areas for CVM1-DRM21-V1 Master Unit

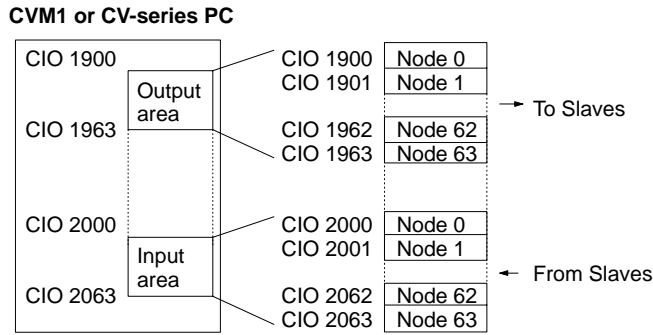

● Allocation Areas for C200HW-DRM21-V1 Master Unit

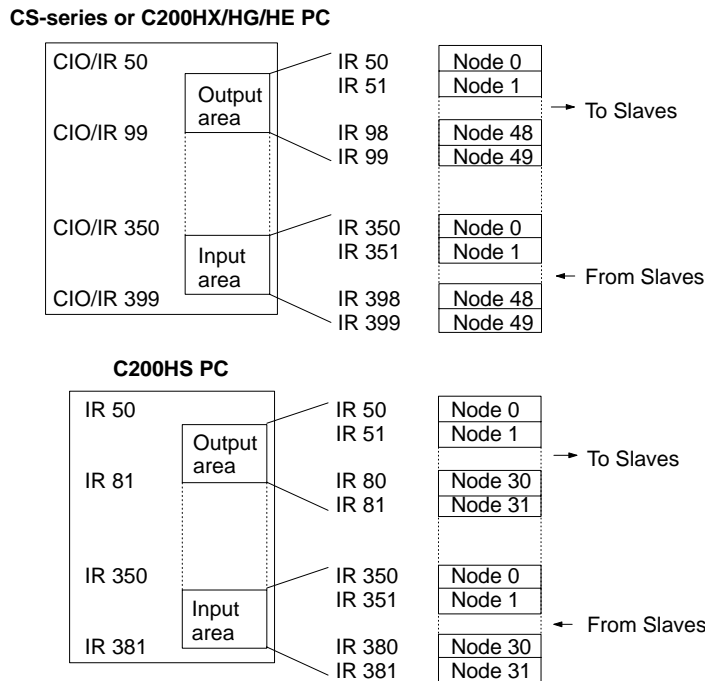

Slaves are allocated input and output words starting from node address 0. One input and output word is allocated for each node address. If a Slave requires more than one input or one output word, then it is assigned more than one node address. If a Slave requires less than one word, it simply uses the right-most bits in the word allocated to it.

■ Free Allocation: With Allocated DM Area Words

When using a CS/CJ-series Master Unit (CS1W-DRM21/CJ1W-DRM21), it is possible to allocate any area to slaves using the allocated DM Area words. Set the following data in the Master User Allocations Table, and then turn ON the Master User Allocations Switch to execute allocation.

1. The area (i.e., CIO, DM, etc.) and first word of the OUT 1 block allocated to DeviceNet remote I/O
2. The area and first word of the IN 1 block allocated to DeviceNet remote I/O
3. The area and the first word of the Allocation Size Setup Table, which indicates the words allocated to each DeviceNet slave.

Free allocation using the allocated DM Area words enables the following.

- Free allocation is possible without using a Configurator.
- Output words do not need to be allocated to Input Units, only input words.
- Slaves that require two words can be allocated two words using only one node address so that the next node addresses can be set for another Slave.

Free allocation using the allocated DM Area words differs from free allocation using the Configurator in the following ways.

- Words can be allocated in order of node address only. Allocation is not possible in any other order.
- Two blocks are used for setting, 1 OUT block and 1 IN block. Allocation is not possible using 4 blocks. (Size of 1 block = 500 words max.)
- The leftmost byte cannot be allocated to slaves with less than 16 points.

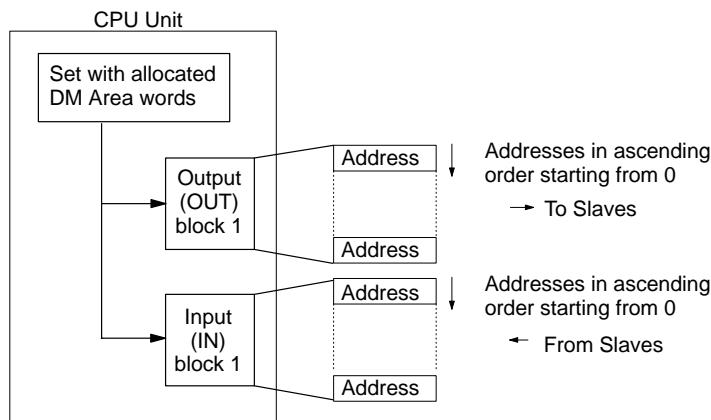

At least one byte (rightmost) is allocated to each address.

- For slaves with more than 16 inputs or outputs, more than one input or output word is allocated to that slave's node address.
- The rightmost byte is allocated to slaves with less than 16 inputs or outputs.

■ Free Allocation: With Configurator

A Configurator can be used to allocate words in the DeviceNet Master Unit in any order by calling parameters of the Master Unit and changing the word allocation of parameters. The following allocations are possible when using a Configurator.

- Output words do not need to be allocated to Input Units, only input words.
- Slaves that require two words can be allocated two words using only one node address so that the next node addresses can be set for another Slave.
- Remote I/O words can be allocated in sequence regardless of the order of the node addresses.

Note The Configurator uses one node address. Therefore, the number of Slaves that can be connected is reduced if the Network is to be operated with the Configurator still connected. The Configurator can be removed, however, after the words have been allocated, and then another Slave can be

connected to the Network in its place so that the number of Slaves that can be connected is not reduced.

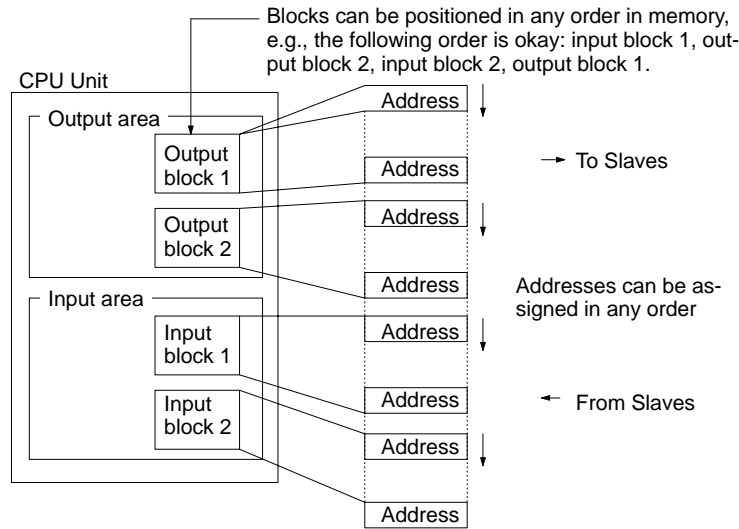

Words are freely allocated to the Slaves and I/O blocks can be set as desired. Each node must be allocated at least one byte (leftmost or rightmost). If a Slave requires more than one input or one output word, then it can be allocated more than one input or output word. If a Slave requires less than one word, it will use either the rightmost or leftmost bits in the word allocated to it.

Free Allocation Restrictions

The following restrictions apply when freely allocating remote I/O.

- The remote I/O allocated to one Slave cannot be separated, i.e., all input words must be consecutive, as must all output words. Inputs and outputs, however, can be separated.
- With a Slave requiring more than one word, a series of allocations cannot be started from the leftmost byte of the remote I/O. The leftmost byte, however, can be allocated to a Slave requiring only 8 bits.
- Multiple words cannot be allocated as the remote I/O for a single Slave.
- A Slave cannot be assigned to more than one Master Unit.

4-1-2 Scan List

A scan list is used to register the Slaves with which the Master Unit communicates in DeviceNet remote I/O communications. It is the basis on which the Master Unit communicates with Slaves.

The Master Unit does not contain a scan list by default. The CS/CJ-series DeviceNet Unit, however, has a default setting that allows it to communicate with all Slaves even with the scan list disabled (scan list disabled mode), but this operating mode should not be used for normal operation. Always create a scan list prior to operating the Unit.

Scan List Contents

The contents of the scan list are given in the following table. When a Master Unit goes online, it compares each of these items with the Slaves that are actually connected to the network. The items that are compared, however, will depend on the allocation method that is used.

Item	Description	Fixed allocations	Free allocations using allocated DM Area words	Free allocations using Configurator
Node address	Node address for every Slave	Compared		Compared
Allocated IN/OUT sizes and allocation area	Settings for the number of bytes allocated to the Master Unit and in which area	Compared		Compared
Vendor	Unique manufacturer ID	Not compared		Set using Configurator
Device type	Unit product type value	Not compared		Set using Configurator
Product code	Unique product model value	Not compared		Set using Configurator
Connection type	Applicable DeviceNet protocol	Automatically set		Automatically set or set using Configurator
Connection path	Type of Slave I/O data	Cannot be set		Set using Configurator

Note With CVM1-DRM21-V1/C200HW-DRM21-V1 Master Units, only node addresses, allocated IN/OUT sizes, and allocated areas are registered in the scan list.

● **Creating the Scan List**

The way that a scan list is prepared varies with the allocation method as shown below.

Fixed allocations	Free allocations using allocated DM Area words	Free allocations using Configurator
With the CPU Unit in PROGRAM mode: 1. Turn ON a Master Fixed Allocation Setting Switch (1 to 3). 2. Turn ON the Scan List Enable Switch.	With the CPU Unit in PROGRAM mode, turn ON the Master User Allocations Setup Switch.	Create a list from the Configurator. (Obtain a list of online devices, use it to create a scan list, and then register the scan list in the Master Unit.)

Note 1. Be sure to create a scan list before starting actual system operation.

Note 2. With fixed allocations, it is possible to communicate with Slaves without creating a scan list (scan list disabled mode). Operating without a scan list, however, may result in faulty operation because the Master Unit will communicate with Slaves even if they do not start up (due to equipment failure, for example).

■ **Scan List Enabled Mode and Scan List Disabled Mode**

A scan list must be created. The scan list modes are explained below.

● **Scan List Enabled Mode (Used for Actual Operation)**

Remote I/O communications are performed according to the registered scan list and only with slaves that are on the list. A verification error occurs if a slave registered on the scan list is not present on the network, if a slave did not start up when remote I/O communications started, or if the number of I/O points did not match the number registered.

● Scan List Disabled Mode (Used When Changing the System Configuration)

In this mode, remote I/O communications (fixed allocations) are performed without a scan list created (or with the scan list cleared). This mode is used when the scan list is temporarily cleared in order to change the system configuration. Do not perform actual system operation without a scan list. Use this mode only to replace a Master Unit or change the system configuration (change a connected Slave or node address).

- Note** 1. To enter Scan List Disabled Mode, turn ON the Scan List Clear Switch during remote I/O communications with the scan list enabled (with fixed allocations, free allocations using the allocated DM Area words, or free allocations using the Configurator). Remote I/O communications will be executed using fixed allocations.
- Note** 2. In Scan List Disabled Mode, all Slaves are targeted for remote I/O communications. Slaves that are connected to the network while communications are in progress are also targeted for communications. Errors cannot be confirmed, however, even if there are slaves present that did not start up (due to equipment failure, for example) because there is no scan list available to check communications against. The communications cycle time will also be significantly longer than the calculated value.
- Note** 3. The scan list is automatically enabled when free allocations are set using the allocated DM Area words or the Configurator. If the list is subsequently cleared using a software switch, the fixed allocations that were used when the list was disabled will be used for remote I/O communications. Make sure the system has stopped before disabling the scan list with a Master Unit that is set for free allocations. In particular, when multiple Master Units are connected to a single network, communications will not be performed normally if one Master Unit on the network is operating with the scan list disabled. Also, once the list is disabled, the free allocations data registered in the Master Unit is lost.

4-1-3 Fixed Word Allocations

■ Allocation Areas for Different PCs

If fixed allocations are used, the node addresses and the words allocated to them are determined according to the PC and Master Unit used. The remote I/O allocation area consists of the input area that receives input from the Slaves, and the output area that writes output data to the Slaves.

● Allocations for CS1W-DRM21 and CJ1W-DRM21 Master Units

Node address	SYSMAC CS/CJ-series Programmable Controllers					
	Fixed allocation area 1		Fixed allocation area 2		Fixed allocation area 3	
	Output area (CIO 3200 to CIO 3263)	Input area (CIO 3300 to CIO 3363)	Output area (CIO3400 to CIO 3463)	Input area (CIO 3500 to CIO 3563)	Output area (CIO 3600 to CIO 3663)	Input area (CIO 3700 to CIO 3763)
0	CIO 3200	CIO 3300	CIO 3400	CIO 3500	CIO 3600	CIO 3700
1	CIO 3201	CIO 3301	CIO 3401	CIO 3501	CIO 3601	CIO 3701
2	CIO 3202	CIO 3302	CIO 3402	CIO 3502	CIO 3602	CIO 3702
...
30	CIO 3230	CIO 3330	CIO 3430	CIO 3530	CIO 3630	CIO 3730
31	CIO 3231	CIO 3331	CIO 3431	CIO 3531	CIO 3631	CIO 3731
32	CIO 3232	CIO 3332	CIO 3432	CIO 3532	CIO 3632	CIO 3732
...	---	---
48	CIO 3248	CIO 3348	CIO 3448	CIO 3548	CIO 3648	CIO 3748
49	CIO 3249	CIO 3349	CIO 3449	CIO 3549	CIO 3649	CIO 3749
50	CIO 3250	CIO 3350	CIO 3450	CIO 3550	CIO 3650	CIO 3750
...	---	---	---	---
62	CIO 3262	CIO 3362	CIO 3462	CIO 3562	CIO 3662	CIO 3762
63	CIO 3263	CIO 3363	CIO 3463	CIO 3563	CIO 3663	CIO 3763

- Note 1.** The fixed allocation area (1, 2, or 3) is selected using a software switch in the area allocated to the Master Unit.
- Note 2.** The words corresponding to the node address of the Master Unit are not actually used by the Master Unit, so they can be used by other Slaves. The actual node address of the Master Unit, however, cannot be the same as the node address of another Slave.
- Note 3.** When Slaves made by other companies are used that are for either output only or input only, both the output area and the input area may be used depending on the status information. Therefore, be sure to check the specifications of the Slave before using any word allocated to a Slave.

● Allocations for CVM1-DRM21-V1 and C200HW-DRM21-V1 Master Units

Node address	SYSMAC Programmable Controllers					
	CV-series PCs		CS1-series and C200HX/HG/HE PCs		C200HS PCs	
	Output area (CIO 1900 to CIO 1963)	Input area (CIO 2000 to CIO 2063)	Output area (IR 50 to IR 99)	Input area (IR 350 to IR 399)	Output area (IR 50 to IR 81)	Input area (IR 350 to IR 381)
0	CIO 1900	CIO 2000	IR 50	IR 350	IR 50	IR 350
1	CIO 1901	CIO 2001	IR 51	IR 351	IR 51	IR 351
2	CIO 1902	CIO 2002	IR 52	IR 352	IR 52	IR 352
...
30	CIO 1930	CIO 2030	IR 80	IR 380	IR 80	IR 380
31	CIO 1931	CIO 2031	IR 81	IR 381	IR 81	IR 381
32	CIO 1932	CIO 2032	IR 82	IR 382	---	---
...	---	---
48	CIO 1948	CIO 2048	IR 98	IR 398	---	---
49	CIO 1949	CIO 2049	IR 99	IR 399	---	---
50	CIO 1950	CIO 2050	---	---	---	---
...	---	---	---	---
62	CIO 1962	CIO 2062	---	---	---	---
63	CIO 1963	CIO 2063	---	---	---	---

Note 1. The words corresponding to the node address of the Master Unit are not actually used by the Master Unit, so they can be used by other Slaves. The actual node address of the Master Unit, however, cannot be the same as the node address of another Slave.

Note 2. When Slaves made by other companies are used that are for either output only or input only, both the output area and the input area may be used depending on the status information. Therefore, be sure to check the specifications of the Slave before using any word allocated to a Slave.

■ Procedure

● CS1W-DRM21 or CJ1W-DRM21 Master Units

Fixed allocation is executed using the software switches in the area allocated to the Master Unit, according to the following procedure.

- Put the CPU Unit in PROGRAM mode.**
Allocation cannot be executed if the CPU Unit is not in PROGRAM mode. Be sure to put the CPU Unit in PROGRAM mode.
- Turn ON the Master Enable Switch.**
It is possible to set CS1W-DRM21 or CJ1W-DRM21 Master Units to function as Slave Units. Enable the Master Unit functionality by turning ON the Master Enable Switch.
- Turn ON the Scan List Clear Switch.**
Disable any scan list that has been created. When the scan list is cleared, all scan list data is lost and so make a backup copy if required.
- Select fixed allocation area.**
Select fixed allocation area 1, 2, or 3.

5. Turn ON the Scan List Enable Switch.

The Master Unit will create and store a scan list based on information from all the Slaves currently participating in the network and operate with this scan list enabled. Slaves that are not participating in the network when this Switch is turned ON are not registered and so check that all the necessary Slaves are participating.

Note If the Master Enable Switch is turned ON when the master function is enabled, or Scan List Clear Switch is turned ON when the scan list is disabled, a C2 error will be generated to indicate a software setting error.

● CVM1-DRM21-V1 or C200HW-DRM21-V1 Master Units

Fixed allocation is executed using the software switches in the area allocated to the Master Unit, according to the following procedure.

1. Put the CPU Unit in PROGRAM mode.

Allocation cannot be executed if the CPU Unit is not in PROGRAM mode. Be sure to put the CPU Unit in PROGRAM mode.

2. Turn ON the Scan List Clear Switch.

Disable any scan list that has been created. When the scan list is cleared, all scan list data is lost and so make a backup copy if required.

3. Turn ON the Scan List Enable Switch.

The Master Unit will create and store a scan list based on information from all the Slaves currently participating in the network and operate with this scan list enabled. Slaves that are not participating in the network when this Switch is turned ON are not registered and so check that all the necessary Slaves are participating.

■ I/O Allocations and Errors

A setup error may occur when the scan list is disabled or a verification error may occur when the scan list is enabled if I/O allocations are not correct.

● Setup Error: I/O Area Overlap

A setup error (I/O Area Overlap) will occur and it will not be possible to start DeviceNet communications if the same word is used by more than one Slave connected to a SYSMAC Master Unit. This error will occur only when the scan list is disabled.

To eliminate the I/O area overlap and clear this error, change the node address setting on one of the Slaves and restart the Master Unit by turning ON the power again or restarting.

● Setup Error: I/O Area Range Violation

A setup error (I/O Area Range Violation) will occur and it will not be possible to start DeviceNet communications if node addresses are set at values that exceed the specified range, or if Slaves that use multiple words are using more words than are specified in the I/O area. This error will occur only when the scan list is disabled.

To eliminate the above problems and clear this error, change the node address setting on the Slaves and restart the Master Unit by turning ON the power again or restarting.

● Verification Error

With the scan list enabled, if there are differences between the information in the scan list and the information from Slaves actually participating in the network, a verification error will occur and it will not

be possible to start DeviceNet communications. This error will occur only when the scan list is enabled. To eliminate and clear this error, either create the scan list again or restore the network configuration corresponding to the scan list.

■ Fixed Allocation Example

Node address	Output points	Input points	Output area	Input area
0	0	8	CIO 3200 Allocation not possible	CIO 3300 Allocation not possible Allocated
1	8	0	CIO 3201 Allocation not possible Allocated	CIO 3301 Allocation not possible
2	0	16	CIO 3202 Allocation not possible	CIO 3302 Allocated
3	16	0	CIO 3203 Allocated	CIO 3303 Allocation not possible
4	8	8	CIO 3204 Allocation not possible Allocated	CIO 3304 Allocation not possible Allocated
5	16	16	CIO 3205 Allocated	CIO 3305 Allocated
6	0 ...	48	CIO 3206 Allocation not possible	CIO 3306 Allocated
7	Master Unit (see note 2)		CIO 3207 Allocation possible	CIO 3307 Allocated
8	32 ...	0	CIO 3208 Allocated	CIO 3308 Allocated
9	(see note 3)		CIO 3209 Allocated	CIO 3309 Allocation possible
10			CIO 3210 Allocated	CIO 3310 Allocated
11	32 ...	32	CIO 3211 Allocated	CIO 3311 Allocated
12	None	None	CIO 3212 Not used	CIO 3312 Not used
63	None	None	CIO 3263 Not used	CIO 3363 Not used

- Note 1.** The above example is for allocations in a CS/CJ-series PC.
- Note 2.** The Master Unit is not allocated any words, so any available node address can be used as node address 7.
- Note 3.** Slaves can be allocated to the words labeled "Allocation possible" as long as the same words are not allocated to more than one Slave.

■ Basic Application Procedure

1. Set the initial settings for the Master Unit:

CS1W-DRM21 or CJ1W-DRM21

- Unit number ("UNIT No." switch on front panel)
- Node address (node address switches on front panel)
- Baud rate (front panel DIP switch pins 1 and 2)
- Communications continue/stop setting for communications error (front panel DIP switch pin 3)
- Hold/clear remote output setting for communications error (front panel DIP switch pin 4)

CVM1-DRM21-V1

- Unit number ("UNIT No." switch on front panel)
- Node address (back panel DIP switch pins 1 to 6)
- Baud rate (front panel DIP switch pins 1 and 2)
- Communications continue/stop setting for communications error (front panel switch pin 3)

C200HW-DRM21-V1

Unit number ("MACHINE No." switch on front panel)

Node address (back panel DIP switch pins 1 to 6)

Baud rate (front panel DIP switch pins 1 and 2)

Communications continue/stop setting for communications error (front panel switch pin 3)

2. Set the initial settings for the Slaves:

Node address (DIP switch)

Baud rate (DIP switch)

Etc.

3. Mount the Master Unit and wire the Network.

For CV-series PCs, Master Units are treated as CPU Bus Units and can be mounted to the CPU Rack or Expansion CPU Rack. Only one Master Unit can be mounted if a Configurator is not used, but up to 16 Master Units can be mounted if a Configurator is used.

For CS-series PCs or C200HX/HG/HE PCs, Masters are treated as Special I/O Units and can be mounted to the CPU Rack or Expansion I/O Rack. Only one Master Unit can be mounted if a Configurator is not used, but up to 10 or 16 Master Units can be mounted if a Configurator is used.

For C200HS PCs, Masters are treated as Special I/O Units and can be mounted to the CPU Rack or Expansion I/O Rack. Only one Master Unit can be mounted if a Configurator is not used, but up to 10 or 16 Master Units can be mounted if a Configurator is used.

4. Connect a Programming Device to the PC and turn ON the power supply to the PC.

5. Generate the I/O table.

6. Turn ON the power supply to the Slaves and turn ON the communications power supply.

7. Switch the PC to PROGRAM mode. (See note 1.)

8. Perform the following and go to step 11. if the scan list was disabled at startup. Otherwise, go to step 9.

a) Turn ON a Fixed Allocation Switch. (See note 2.)

b) Confirm that communications are possible with the registered slaves by monitoring the Registered Slave Data Area.

c) From a Programming Device connected to the PC, turn ON the Scan List Enable Bit in the software switches (bit 0).

Remote I/O communications will start with the scan list enabled. The software switches can be used to start and stop remote I/O communications.

9. Perform the following from the Programming Device connected to the PC and go to step 11. if the scan list was enabled at startup and you want to re-register the scan list. Otherwise, go to step 10.

a) Turn ON the Scan List Clear Bit in the software switches (bit 1).

b) Turn ON a Fixed Allocation Switch. (See note 2.)

c) Confirm that communications are possible with the registered slaves by monitoring the Registered Slave Data Area.

d) Turn ON the Scan List Enable Bit in the software switches (bit 0).

Remote I/O communications will start with the scan list enabled. The software switches can be used to start and stop remote I/O communications.

10. Do nothing if the scan list was enabled at startup and the scan list does not need to be changed.

Remote I/O communications will start with the scan list enabled. The software switches can be used to start and stop remote I/O communications. Go to step 11.

- 11. Confirm that the MS and NS indicators on all Master Units and Slaves are lit.
- 12. Switch the PC to RUN mode.

Note 1. With the CS1W-DRM21 or CJ1W-DRM21, if the slave function is being used, switch to the master function by turning ON the Master Enable Switch.

Note 2. This operation is not required with the CVM1-DRM21-V1 or C200HW-DRM21-V1 because there is only one fixed allocation area.

4-1-4 Free Allocations

■ Allocation Areas and Maximum Words for Different PCs and Master Units

When free allocations are used, the remote I/O areas consist of IN blocks, which input Slave data to the PC, and OUT blocks, which output data from the PC to the Slaves. These blocks can be allocated as desired using the following words. Each block, however, must consist of continuous words within one data area.

● CS1W-DRM21 and CJ1W-DRM21 Master Units

PC	CS/CJ Series (all models)	
	Set using allocated DM Area words (See note 1.)	Set using Configurator
Words that can be allocated	CIO: 0000 to 6143 WR: W000 to W511 HR: HR000 to HR511 DM: D00000 to D32767 EM: E00000 to E32767 (Banks 0 to C)	
Maximum number of words	1 block: 500 words max. OUT 1 and IN 1 can be created anywhere in the above areas. (Maximum: 1,000 words)	1 block: 500 words max. OUT 1, IN 1, OUT 2, and IN 2 can be created anywhere in the above areas. (Maximum: 2,000 words)

Note 1. Free allocation using allocated DM Area words is only possible with the CS1W-DRM21 or CJ1W-DRM21. To perform free allocation with other Master Units, use the Configurator.

Note 2. The Data Memory (DM) Area cannot be manipulated by bit, so it is not suitable as the remote I/O allocation area for the Inverter.

• CVM1-DRM21-V1 and C200HW-DRM21-V1 Master Units

PC	SYSMAC Programmable Controllers					
	CV-series PCs		CS1-series PCs (all models)	C200HX/HG/HE PCs		C200HS PCs (all models)
	CV500/ CVM1-CPU01-E	All other models		C200HE-CPU11-E	All other models	
Words that can be allocated	CIO 0000 to CIO 2427	CIO 0000 to CIO 2555	CIO 000 to CIO 235, CIO 300 to CIO 511	IR 000 to IR 235, IR 300 to IR 511		IR 000 to IR 235, IR 300 to IR 511
	G008 to G255		HR 000 to H099, CIO 1000 to CIO 1063	HR 00 to HR 99 LR 00 to LR 63		HR 00 to HR 99 LR 00 to LR 63
	D00000 to D08191	D00000 to D24575	D00000 to D05999	DM 0000 to DM 4095	DM 0000 to DM 5999	DM 0000 to DM 5999
Maximum number of words	Each block can be up to 100 words (including unused areas). The total number of words in all four blocks must be 400 words or less.		Each block can be up to 100 words (including unused areas). The total number of words in all four blocks must be 300 words or less (including unused areas). If message communications are used, the total number of words in all four blocks must be 100 words or less.		The total number of words in all four blocks must be 80 words or less (including unused areas).	

Note 1. The Data Memory (DM) Area cannot be manipulated by bit, so it is not suitable as the remote I/O allocation area for the Inverter.

Note 2. If a CPU Bus Link is used with a CV-series PC, the G Area is used for the CPU Bus Link, making it impossible to use this area for DeviceNet communications.

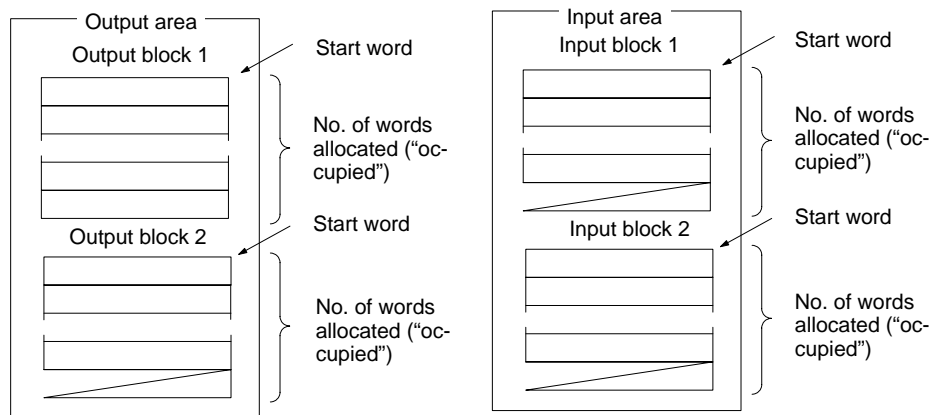

Note 1. OUT 1 and IN 1 can be set using the allocated DM Area words. For each block, set the area, the start word, and the number of words allocated to each Slave.

Note 2. OUT 1, IN 1, OUT 2, and IN 2 can be set using a Configurator. For each block, set the area, the start word, the number of words allocated to the block, and the number of words allocated to each Slave.

Free Allocation Restrictions

- Each node address can be set only once in the output blocks and once in the input blocks.

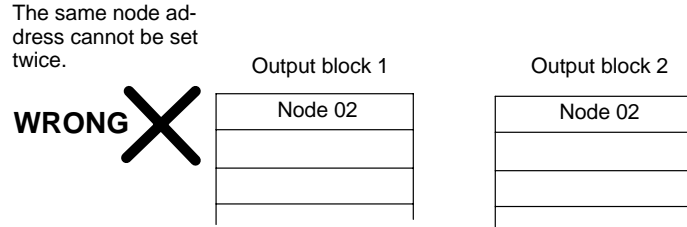

- If a Configurator is used to freely allocate words or bytes to each Slave, only a Slave using only one byte (8 bits) can be set in the leftmost byte of the allocated word. Slaves with more than 8 bits cannot be set for the leftmost bit of the allocated word.

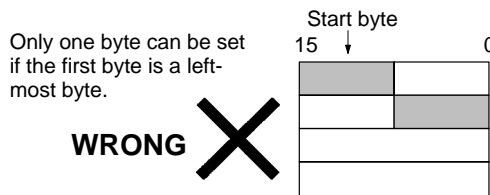

- The same Slave cannot be allocated words in more than one Master.

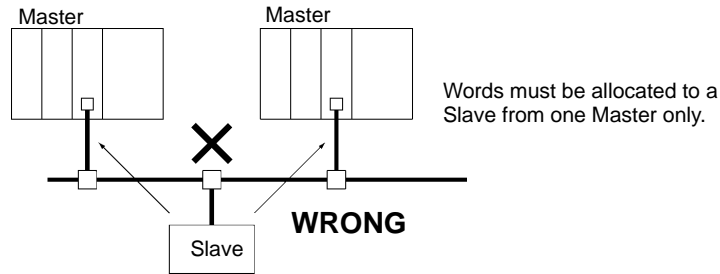

Note The master parameter file duplication check from the Configurator can be used to check for node addresses that have been set more than once in the scan list, which shows the I/O allocations that have been made.

- Always use the Configurator when there is more than one Master and enable the scan lists. A Bus OFF error can occur if there is more than one Master with the scan list disabled on the same Network.

Free Allocation Restrictions When Using Allocated DM Area Words

Allocation in Order of Node Address

When using allocated DM Area words, words are allocated in order of node address. It is possible not to allocated words to a node address but the order cannot be changed.

Only OUT 1 and IN 1 Can Be Used

When using allocated DM Area words, only two blocks (OUT 1 and IN 1) can be allocated. Four blocks can be allocated using the Configurator.

Slaves of 1 Byte or Less Can Not Be Allocated to the Leftmost Byte

With the Configurator, Slaves requiring one byte or less can be allocated the leftmost byte of a word, but this is not possible when using allocated DM Area words.

■ Example of Free Allocations (Using the Configurator)

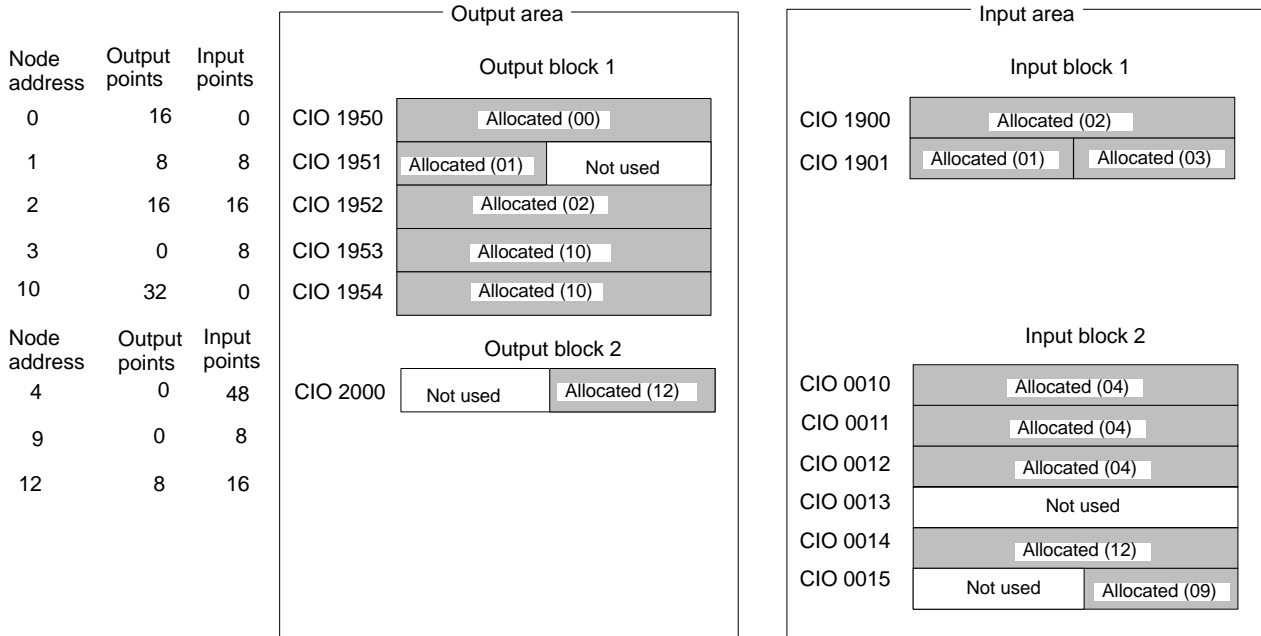

Note 1. The above example is for a CS/CJ-series PC using the Configurator.

Note 2. When using allocated DM Area words, output block 2 and input block 2 cannot be set. Also, it is not possible to allocate only the leftmost byte of a word (as with node address 01 in the above example).

■ Basic Application Procedure

1. Set the initial settings for the Master Unit:

CS1W-DRM21 or CJ1W-DRM21

Unit number ("UNIT No." switch on front panel)

Node address (node address switches on front panel)

Baud rate (front panel DIP switch pins 1 and 2)

Communications continue/stop setting for communications error (front panel DIP switch pin 3)

Hold/clear remote output setting for communications error (front panel DIP switch pin 4)

CVM1-DRM21-V1

Unit number ("UNIT No." switch on front panel)

Node address (back panel DIP switch pins 1 to 6)

Baud rate (front panel DIP switch pins 1 and 2)

Communications continue/stop setting for communications error (front panel switch pin 3)

C200HW-DRM21-V1

Unit number ("MACHINE No." switch on front panel)

Node address (back panel DIP switch pins 1 to 6)

Baud rate (front panel DIP switch pins 1 and 2)

Communications continue/stop setting for communications error (front panel switch pin 3)

2. Set the initial settings for the Slaves:

Node address (DIP switch)

Baud rate (DIP switch)

Etc.

3. Mount the Master Unit and wire the Network.

For CV-series PCs, Master Units are treated as CPU Bus Units and can be mounted to the CPU Rack or Expansion CPU Rack. Up to 16 Master Units can be mounted if a Configurator is used.

For CS1-series PCs or C200HX/HG/HE PCs, Masters are treated as Special I/O Units and can be mounted to the CPU Rack or Expansion I/O Rack. Up to 10 or 16 Master Units can be mounted if a Configurator is used.

For C200HS PCs, Masters are treated as Special I/O Units and can be mounted to the CPU Rack or Expansion I/O Rack. Up to 10 or 16 Master Units can be mounted if a Configurator is used.

4. Connect a Programming Device to the PC and turn ON the power supply to the PC.
5. Generate the I/O table.
6. Turn OFF the power to the PC.
7. Go to step 8. if only one Master Unit is being used. Go to step 15. if more than one Master Unit is being used in the same Network. Go to step 29. if allocated DM Area words are used for allocations.
8. Connect a Configurator to the Network.
9. Turn ON the power supply to all nodes.
10. Switch the PC to PROGRAM mode. (See note.)
11. Get the device list and create the master parameters with the Configurator.
12. If more than one Master Unit is mounted to the same PC, use the Configurator to check for duplication in the master parameter settings.
13. Register the master parameters in the Master Unit(s).
14. Go to step 32.
15. Connect a Configurator to the Network.
16. Turn ON the power supply to all the Slaves.
17. Read the Network configuration from the Configurator. (See note.)
18. Turn OFF the power supply to all the Slaves.
19. Create the master parameters for each Master Unit and save the parameters in files.
20. Turn ON the power supply to one PC (i.e., to one of the Master Units).
21. Switch the PC to PROGRAM mode.
22. Read the Network configuration from the Configurator.
23. Read the master parameter file for the Master Unit that has been turned ON from the master parameter editing screen.
24. Write the master parameters created in the above step 19.
25. Turn OFF the power supply to the PC (i.e., the Master Unit) and the Slaves.
26. Repeat the above steps beginning at step 20. for all Master Units.
27. Turn ON the power supply to all Masters and Slaves.
28. Go to step 32.
29. Switch the PC to PROGRAM mode. (See note.)
30. Set the Master User Allocations Tables for the allocated DM Area words in each Master Unit.
31. Turn ON the Master User Allocations Switch for each Master Unit.

32. Remote I/O communications will start with the scan list enabled. (Communications will not start if they have been set to be stopped at startup from the Configurator.) Use the software switches or Configurator to start and stop remote I/O communications.
33. Confirm that the MS and NS indicators on all Master Units and Slaves are lit.
34. Read the Network configuration from the Configurator.
35. Save the Network configuration in a file from the Configurator.
36. Switch the PC to RUN mode.

Note With the CS1W-DRM21 or CJ1W-DRM21, if the slave function is being used, switch to the master function by turning ON the Master Enable Switch.

4-2 SYSDRIVE 3G3MV Settings

In order to perform DeviceNet communications, it is necessary to make settings for the Inverter according to the application.

Note The parameters set here are applied to the DeviceNet Communications Unit when the power is turned ON. Turn OFF the power after changing parameters and turn ON again to apply them.

4-2-1 Run Command Selection

Constant	Register number (Hex)	Name	Content	Setting range	Setting unit	Default setting	Write during operation
n003	0103	Run command source selection	<p>Selects the run/stop command input method for the Inverter. (Becomes valid when the Remote mode is selected from Local/Remote.)</p> <p>0: Run/stop commands from the Digital Operator are valid.</p> <p>1: Terminal block (multi-function input) run commands are valid.</p> <p>2: RS-422/485 communications run commands are valid.</p> <p>3. Run commands from the Optional Unit (DeviceNet Communications Unit) are valid.</p> <p>Note In Local mode, run commands are restricted to those performed using the operation keys of the Digital Operator.</p>	0, 1, 2, 3	1	0	No

Perform the above setting according to the source of the run commands (forward operation, reverse operation, STOP) in the application. When run commands (forward operation, reverse operation, STOP) are always to be made from DeviceNet communications, set to “3.”

● Switching of Run Commands from DeviceNet Communications

There is a switching signal, “Net. Ctrl.,” for run commands from the standard remote I/O of the DeviceNet Communications Unit. The input method for run commands can be changed in the following way using the “Net. Ctrl.” signal.

Net. Ctrl. = 1 (ON): Automatically sets the n003 constant to “3,” making run commands from DeviceNet communications valid (remote I/O run commands become valid). If the bit turns OFF, n003 will return to its original value.

Net. Ctrl. = 0 (OFF): The run command input method specified by n003 becomes valid.

4-2-2 Frequency Reference Selection

Constant	Register number (Hex)	Name	Content	Setting range	Setting unit	Default setting	Write during operation
n004	0104	Frequency reference source selection	<p>Selects the frequency reference input method for the Inverter. (Becomes valid when the Remote mode is selected from Local/Remote.)</p> <p>0: Digital Operator frequency settings are valid.</p> <p>1: Frequency reference 1 (n024) is valid.</p> <p>2: Frequency reference control terminal (0 to 10-V voltage input) is valid.</p> <p>3: Frequency reference control terminal (4 to 20-mA current input) is valid. (Also, set SW2 on the control board from V to I.)</p> <p>4: Frequency reference control terminal (0 to 20-mA current input) is valid. (Also, set SW2 on the control board from V to I.)</p> <p>5: Pulse train reference control terminal is valid. (Pulse train input scale: n149 sets the highest pulse input.)</p> <p>6: Frequency reference from RS-422/485 communications (0002 Hex) is valid.</p> <p>7: Multi-function analog voltage input (0 to 10 V) is valid.</p> <p>8: Multi-function analog current input (4 to 20 mA) is valid.</p> <p>9: Frequency reference from the Optional Unit (DeviceNet Communications Unit) is valid.</p>	0 to 9	1	0	No

Perform the above setting according to the source of the frequency reference in the application. When frequency references from the DeviceNet communications are to be always used, set to "9." If this setting is performed, frequency reference 1 can only be set through DeviceNet communications. However, frequency references 2 to 16 and the inching frequency can be set from DeviceNet communications or the Digital Operator regardless of the setting of n004.

● **Switching of Frequency References from DeviceNet Communications**

There is a switching signal, “Net. Ref.,” for frequency references (speed references) from the standard remote I/O of the DeviceNet Communications Unit. The input method for frequency references can be changed in the following ways using the “Net. Ref.” signal.

Net. Ctrl. = 1 (ON): Automatically sets the n004 constant to “9,” making frequency references from DeviceNet communications valid (remote I/O frequency references become valid). If the bit turns OFF, n004 will return to the original value.

Net. Ctrl. = 0 (OFF): The frequency reference specified by n004 becomes valid.

4-2-3 Frequency Reference Settings and Display Units

Perform the following settings to specify units for data related to frequencies (speeds) used in DeviceNet communications. The standard unit used with DeviceNet is r/min, so always set the number of motor poles.

Con-stant	Register number (Hex)	Name	Content	Setting range	Setting unit	Default setting	Write during operation
n035	0123	Frequency reference setting and display units	<p>Sets the units for the frequency reference and frequency monitor that are set and referred to by the Digital Operator.</p> <p>0: 0.01-Hz units 1: 0.1% units 2 to 39: r/min units (Set the number of motor poles) 40 to 3999: Optional Unit settings. (Specifies the value used to set and display the maximum frequency.)</p> <p>□□□□</p> <p>↑ ↑ Set a value without the decimal point. Set the position of the digit where the decimal point is to be displayed starting from the rightmost digit.</p> <p>Example: To display the maximum frequency as “50.0,” specify “1500.”</p> <p>Note 1. Only units for frequency reference and the frequency monitor will change.</p> <p>Note 2. The settings are valid in either Local or Remote mode.</p>	0 to 3999	1	0	No

4-3 Startup Procedure

The DeviceNet communications system can be started from any of the nodes on the Network. The following procedure gives the startup process after turning ON the power to the Inverter's DeviceNet Communications Unit. If the startup process shown below is interrupted or stops before being completed, an error will occur. Correct errors that occur, referring to *Chapter 6 Communications Errors*.

1. Turn ON the power.
2. The PWR indicator will turn ON: Power is being supplied.
3. The MS indicator will be lit red and then green: Confirming MS indicator status.
4. The NS indicator will be lit red and then green: Confirming MS indicator status.
5. The MS indicator will flash: Shows Optional Unit startup processing status.
6. The MS indicator will be lit: The Optional Unit is ready.
7. The NS indicator will flash: The Optional Unit is connected to the Network and startup processing is being performed.
8. The NS indicator will be lit: The Network is started.

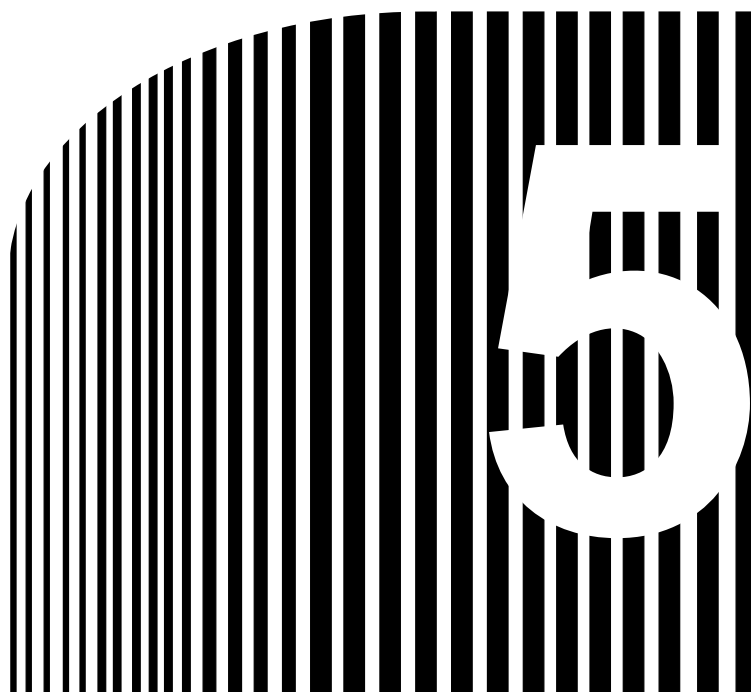

Chapter 5

• **DeviceNet Communications Unit Operations** •

- 5-1 Remote I/O
- 5-2 Switching Remote I/O Operation
- 5-3 Special Remote I/O Operation
- 5-4 Control Remote I/O Operation
- 5-5 Message Communications
(DeviceNet Explicit Messages)
- 5-6 3G3MV Register Numbers, Classes, Instances,
and Attributes

 **Caution** Do not carelessly change Inverter's settings. Doing so may result in injury or damage to the product.

 **Caution** Be sure to perform the setting switch settings correctly and confirm the settings before starting operation. Not doing so may result in malfunction or damage to the product.

5-1 Remote I/O

There are two types of DeviceNet communications: Remote I/O and message communications. There are four types of remote I/O operation: Basic remote I/O, standard remote I/O, special remote I/O, and control remote I/O. This section explains standard remote I/O operations and the types of remote I/O.

Note 1. To use special remote I/O or control remote I/O, it is necessary to switch the remote I/O operation. Switching the remote I/O operation involves the use of message communications, so refer to *5-5 Message Communications* and *5-2 Switching Remote I/O Operations*. Also, for details regarding special remote I/O, refer to *5-3 Special Remote I/O*.

Note 2. When the DeviceNet Communications Unit is used, the RS-422/485 of the Inverter cannot be used for communications.

5-1-1 Standard Remote I/O (Initial Setting)

The type of remote I/O operation pre-set as the initial setting for the Inverter's DeviceNet Communications Unit is standard remote I/O. This remote I/O can be used for general Inverter control.

DeviceNet Master Unit
 CS1W-DRM21
 CJ1W-DRM21
 C200HW-DRM21-V1
 CVM1-DRM21-V1

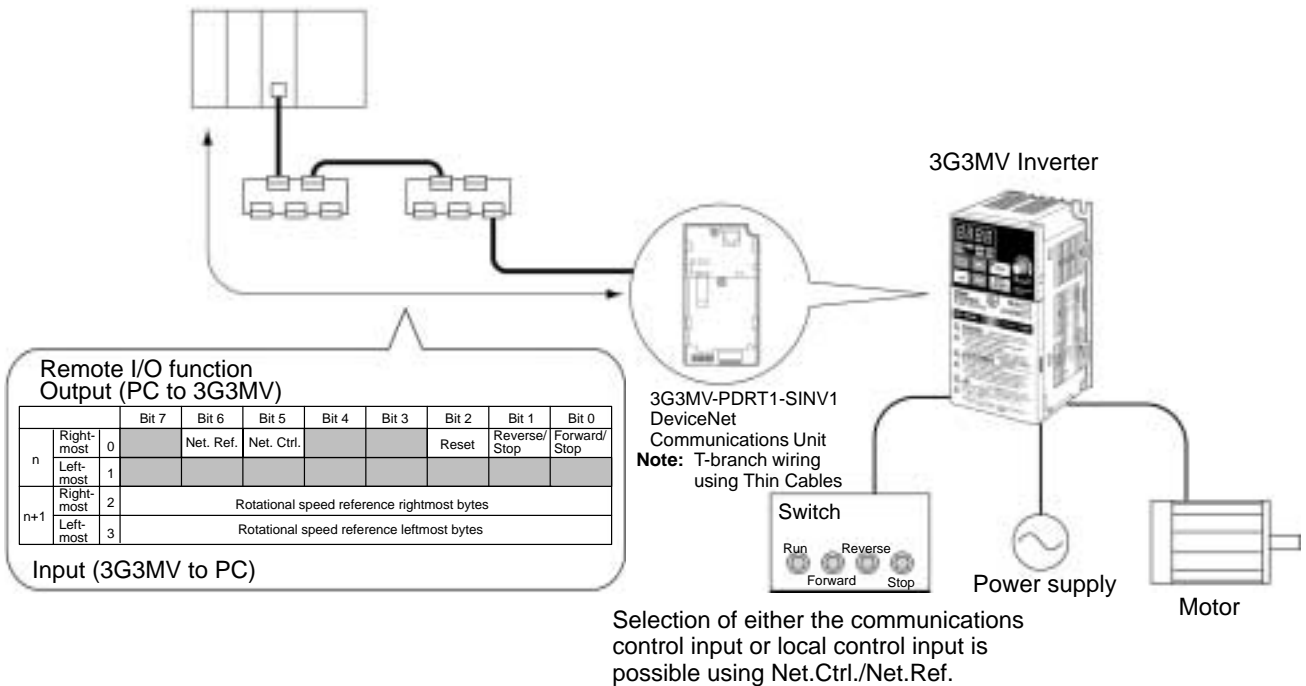

Note When the DeviceNet Communications Unit is used, the RS-422/485 of the Inverter cannot be used for communications.

■ Words Allocated to SYSDRIVE 3G3MV Inverters

A SYSDRIVE 3G3MV Inverter is allocated a total of four SYSMAC I/O words (two input and two output) via a DeviceNet Communications Unit.

I/O classification	Word address	Bits	
		15 to 8	7 to 0
Output (SYSMAC PC to Inverter)	n	Not used.	Inverter run commands
	n+1	Rotational speed reference (leftmost bits)	Rotational speed reference (rightmost bits)
Input (Inverter to SYSMAC PC)	m	Not used.	Inverter status
	m+1	Rotational speed monitor (leftmost bits)	Rotational speed monitor (rightmost bits)

● Inverter Run Commands

Word	n							
Bit	Bit 7	Bit 6	Bit 5	Bit 4	Bit 3	Bit 2	Bit 1	Bit 0
Signal name	Not used.	Net Reference	Net Control	Not used.	Not used.	Fault Reset	Reverse/stop	Forward/stop
Content	---	0: n004 1: DeviceNet (See note 1.)	0: n003 1: DeviceNet (See note 2.)	---	---	0: --- 1: Fault Reset	0: Stop 1: Reverse	0: Stop 1: Forward

Note 1. Net Reference is used to specify the frequency reference as follows (cannot be changed during running):

0: The frequency reference input method specified by the frequency reference source selection (n004) is used.

1: Set n004 to “9” and operate via DeviceNet. (Operate with rotational speed reference in word n+1.)

Note 2. Net Control is used to change the run command as follows (cannot be changed during running):

0: The run command input method specified by the run command source selection (n003) is used.

1: Set n003 to “3” and operate via DeviceNet. (Follow run command in word n, bits 0 and 1.)

● Inverter Status

Word	m							
Bit	Bit 7	Bit 6	Bit 5	Bit 4	Bit 3	Bit 2	Bit 1	Bit 0
Signal name	At Reference	Reference From Net	Control From Net	Inverter Ready	During reverse run	During forward run	Alarm (Minor Fault)	Fault
Content	0: Accelerating or Decelerating 1: At reference	0: n004 1: DeviceNet (See note 1.)	0: n003 1: DeviceNet (See note 2.)	0: Preparing 1: Ready	0: Stop/forward 1: During reverse run (See note 4.)	0: Stop/reverse 1: During forward run (See note 5.)	0: Normal 1: Alarm (Minor Fault)	0: Normal 1: Fault

Note 1. Reference From Net shows the input status of word n, bit 6 (Net Reference) for DeviceNet communications.

Note 2. Control From Net shows the input status of word n, bit 5 (Net Control) for DeviceNet communications.

Note 3. Reverse Operation indicates reverse output status. This bit does not turn ON for DC braking (DC injection).

Note 4. Forward Operation indicates either forward run status or DC braking (DC injection) status. This bit turns ON even for DC braking (DC injection) during reverse run.

● **Rotational Speed Reference Data**

Word address	n+1															
Bit	15	14	13	12	11	10	9	8	7	6	5	4	3	2	1	0
Signal name	Rotational speed reference data															
Content	Communications data = Rotational speed reference x 2 ^a a: Speed scale value of Class 2A, Instance 01, Attribute 16 (Initial value: 0) The speed scale is assigned to the message function. For instructions on how to change it, refer to 5-5 Message Communications. The unit for the rotational speed reference is set in n035 (frequency reference setting and display units) Setting example (providing reference of 1,800 r/min): When the speed scale value is "0" and the number of motor poles is set in n035 (so unit is r/min): 1,800 r/min → 1,800 x2 ⁰ → 1,800 → 0708 Hex															

Note 1. Under the DeviceNet protocol, the unit for the speed reference is fixed as r/min. The number of motor poles (2 to 39) must be set in parameter n035 (frequency reference setting and display units) when using DeviceNet (open network).

Note 2. If the setting is not within the proper range, the previous data will be retained and the designated rotational speed will not be entered.

● **Rotational Speed Monitor Data**

Word address	m+1															
Bit	15	14	13	12	11	10	9	8	7	6	5	4	3	2	1	0
Signal name	Rotational speed monitor data															
Content	Communications data = Rotational speed monitor x 2 ^a a: Speed scale value of Class 2A, Instance 01, Attribute 16 (Initial value: 0) The speed scale is assigned to the message function. For instructions on how to change it, refer to 5-5 Message Communications. The unit for the rotational speed monitor is set in n035 (frequency reference setting and display units) Data conversion example: When the speed scale value is "0" and the number of motor poles is set in n035, and the read data is 03E8 Hex: 03E8 Hex → 1,000 → 1,000/2 ⁰ → 1,000 r/min															

Note Under the DeviceNet protocol, the unit for the speed reference is fixed as r/min. The number of motor poles (2 to 39) must be set in parameter n035 (frequency reference setting and display units) when using DeviceNet (open network).

5-1-2 Types of Remote I/O Operation

There are four types of DeviceNet Communications Unit remote I/O operation:

- Basic remote I/O: Remote I/O operation for the standard DeviceNet configuration.
- Standard remote I/O: Remote I/O operation (DeviceNet-compatible) that is the default setting for the DeviceNet Communications Unit.
- Special remote I/O: Remote I/O operations that enable using all the functions of 3G3MV Inverters, and accessing/setting for all parameters. (Special remote I/O operation is special for this product; they are not compatible with DeviceNet.)

- Control remote I/O: Remote I/O operation that contains functions and arrays matching the Inverter control terminal I/O signals. The Inverter’s multi-function I/O functions can be used during communications. (Control remote I/O operation is a special function of this product; it is not compatible with DeviceNet.)

The default setting is for standard remote I/O operation, so it will be necessary to switch to either of the other types of remote I/O operation if desired. Switching the remote I/O operation involves the use of message communications. Refer to 5-5 Message Communications and 5-2 Switching Remote I/O Operation.

■ Basic Remote I/O

Basic remote I/O is used for the standard DeviceNet configuration.

● Outputs (SYSMAC PC to 3G3MV) Instance ID: 20 Dec (14 Hex)

Byte number			Bit 7	Bit 6	Bit 5	Bit 4	Bit 3	Bit 2	Bit 1	Bit 0
Wd n	Rightmost	0						Fault Reset		Forward/stop
	Leftmost	1								
Wd n+1	Rightmost	2	Rotational speed reference (rightmost data)							
	Leftmost	3	Rotational speed reference (leftmost data)							

● Inputs (3G3MV to SYSMAC PC) Instance ID: 70 Dec (46 Hex)

Byte number			Bit 7	Bit 6	Bit 5	Bit 4	Bit 3	Bit 2	Bit 1	Bit 0
Wd m	Rightmost	0						During forward run		Fault
	Leftmost	1								
Wd m+1	Rightmost	2	Rotational speed reference (rightmost data)							
	Leftmost	3	Rotational speed reference (leftmost data)							

Note 1. A shaded box indicates that the bit is not used.

Note 2. The basic remote I/O operation is the same as those explained for standard remote I/O. (Basic remote I/O restricts the operation of standard remote I/O.)

■ Standard Remote I/O

Standard remote I/O is the default setting for the DeviceNet Communications Unit.

● Outputs (SYSMAC PC to 3G3MV) Instance ID: 21 Dec (15 Hex)

Byte number			Bit 7	Bit 6	Bit 5	Bit 4	Bit 3	Bit 2	Bit 1	Bit 0
Wd n	Rightmost	0		Net Reference	Net Control			Fault Reset	Reverse/stop	Forward/stop
	Leftmost	1								
Wd n+1	Rightmost	2	Rotational speed reference (rightmost data)							
	Leftmost	3	Rotational speed reference (leftmost data)							

● Inputs (3G3MV to SYSMAC PC)

Instance ID: 71 Dec (47 Hex)

Byte number			Bit 7	Bit 6	Bit 5	Bit 4	Bit 3	Bit 2	Bit 1	Bit 0
Wd m	Rightmost	0	At Reference	Reference From Net	Control From Net	Inverter Ready	During reverse run	During forward run	Alarm (minor fault)	Fault
	Leftmost	1								
Wd m+1	Rightmost	2	Rotational speed monitor (rightmost data)							
	Leftmost	3	Rotational speed monitor (leftmost data)							

Note A shaded box indicates that the bit is not used.

■ Special Remote I/O

Special remote I/O enables using all the functions of 3G3MV Inverters, and accessing/setting all parameters.

● Outputs (SYSMAC PC to 3G3MV)

Instance ID: 100 Dec (64 Hex)

Byte number			Bit 7	Bit 6	Bit 5	Bit 4	Bit 3	Bit 2	Bit 1	Bit 0
Wd n	Rightmost	0	Function code (write/read code)							
	Leftmost	1	Register number, leftmost byte (register number assigned to various parameters, etc.)							
Wd n+1	Rightmost	2	Register number, rightmost byte (register number assigned to various parameters, etc.)							
	Leftmost	3	Register data, leftmost byte (data to write to specified register)							
Wd n+2	Rightmost	4	Register data, rightmost byte (data to write to specified register)							

● Inputs (3G3MV to SYSMAC PC)

Instance ID: 150 Dec (96 Hex)

Byte number			Bit 7	Bit 6	Bit 5	Bit 4	Bit 3	Bit 2	Bit 1	Bit 0
Wd m	Rightmost	0	Function code (returns transmitted code)							
	Leftmost	1	Register number, leftmost byte (returns transmitted register number)							
Wd m+1	Rightmost	2	Register number, rightmost byte (returns transmitted register number)							
	Leftmost	3	Register data, leftmost byte (return transfer data amount or read data)							
Wd m+2	Rightmost	4	Register data, rightmost byte (return transfer data amount or read data)							

Note 1. Special remote I/O outputs and inputs are paired. When using special remote I/O, be sure to set them together.

Note 2. Special remote I/O objects do not conform to the AC/DC drive profile, but are specially set for this product.

Note 3. The 16-bit data (register number and register data) is set using two words for each setting.

Note 4. Be careful of the order of the leftmost and rightmost bytes of the 16-bit data. The order is reversed from that of basic and standard remote I/O.

Note 5. For details on special remote I/O operation, refer to 5-3 *Special Remote I/O*.

■ **Control Remote I/O**

Control remote I/O enables using the functions and arrays of the Inverter control terminal I/O signals. The Inverter’s multi-function I/O functions can be used during communications.

● **Outputs (SYSMAC PC to 3G3MV)**

Instance ID: 101 Dec (65 Hex)

Byte number			Bit 7	Bit 6	Bit 5	Bit 4	Bit 3	Bit 2	Bit 1	Bit 0
Wd n	Rightmost	0		Multi-function input 7	Multi-function input 6	Multi-function input 5	Multi-function input 4	Multi-function input 3	Stop/reverse	Stop/forward
	Leftmost	1	Multi-function output 2	Multi-function output 1	Multi-function contact output				Fault reset	External fault input
Wd n+1	Rightmost	2	Frequency reference, rightmost byte							
	Leftmost	3	Frequency reference, leftmost byte							
Wd n+2	Rightmost	4								
	Leftmost	5								
Wd n+3	Rightmost	6								
	Leftmost	7								

● **Inputs (3G3MV to SYSMAC PC)**

Instance ID: 151 Dec (97 Hex)

Byte number			Bit 7	Bit 6	Bit 5	Bit 4	Bit 3	Bit 2	Bit 1	Bit 0
Wd m	Rightmost	0	Fault	Alarm (minor fault)	Inverter Ready	At reference	During re-set input	During reverse run	Zero speed	During run
	Leftmost	1			Multi-function output 2	Multi-function output 1	Multi-function contact output	Local/remote	Undervoltage	Operation fault
Wd m+1	Rightmost	2	Output frequency monitor, rightmost byte							
	Leftmost	3	Output frequency monitor, leftmost byte							
Wd m+2	Rightmost	4	Torque reference monitor, rightmost byte							
	Leftmost	5	Torque reference monitor, leftmost byte							
Wd m+3	Rightmost	6	Output current monitor, rightmost byte							
	Leftmost	7	Output current monitor, leftmost byte							

Note 1. A shaded box indicates that the bit is not used.

Note 2. Control remote I/O inputs and outputs are paired. When using control remote I/O, be sure to set them together.

Note 3. Control remote I/O objects do not conform to the AC/DC drive profile, but are specially set for this product.

Note 4. For details of control remote I/O functions, refer to *5-4 Control Remote I/O Operation*.

5-2 Switching Remote I/O Operation

To use remote I/O operations other than the standard remote I/O operation it is necessary to switch the remote I/O operation. There are two ways to switch:

- Set the remote I/O instance IDs for parameter objects.
- Set the remote I/O instance IDs for connection objects.

When using an OMRON Master Unit, set the remote I/O instance IDs for parameter objects, using the Master Unit's message functions or the Configurator. When using a CS1W-DRM21 or CJ1W-DRM21 Master Unit, the connection object at communications startup can be specified using the Configurator. Set the connection path from the Configurator.

■ Switching via Parameter Objects (Using the Configurator)

To switch remote I/O operations using parameter objects, the appropriate instance IDs must be set for the following parameter objects.

- Switching remote I/O inputs (3G3MV to SYSMAC PC):
Class 101 Dec (65 Hex), Instance 01 Dec (01 Hex), Attribute 01 Dec (01 Hex)
- Switching remote I/O outputs (SYSMAC PC to 3G3MV)
Class 101 Dec (65 Hex), Instance 01 Dec (01 Hex), Attribute 02 Dec (02 Hex)

The instances to be set are shown in the following table.

Remote I/O type	Instance ID	
	Inputs (3G3MV to PC)	Outputs (PC to 3G3MV)
Basic remote I/O	70 Dec (46 Hex)	20 Dec (14 Hex)
Standard remote I/O	71 Dec (47 Hex)	21 Dec (15 Hex)
Special remote I/O	150 Dec (96 Hex)	100 Dec (64 Hex)
Control remote I/O	151 Dec (97 Hex)	101 Dec (65 Hex)

The procedure for switching remote I/O operations by means of parameter objects using the Configurator is as follows:

1. Connect the 3G3MV Inverter and a Configurator to the DeviceNet communications network. At least a 3G3MV DeviceNet Communications Unit and a Configurator must be connected.
2. Set up the explicit message connection
 - Turn ON the power to the Configurator and all Units participating in communications and press the Configurator's online button. This will put the system into online status.
 - Click the *Device List* button at the upper left corner of the Configurator screen. With this, the explicit message connection will be set up.
3. Connect the remote I/O to be used for the parameter objects.
 - Select *Tool (T)* and then *Device Parameter Setting (P)* from the Configurator tool bar to display the parameter setting tool.
 - Set the node address, and then set the remote I/O instance IDs for the parameter objects described above (attributes 01 and 02 Hex of class 65 Hex, instance 01 Hex).
4. Change the Master Unit and 3G3MV Inverter connection to the set connection.
 - Reset the power to the Master Unit and 3G3MV Inverter. The remote I/O connection will then start up with the specified remote I/O operation.

- When creating scan lists, set the scan list to disable mode once and then create scan lists or change the settings as follows for the Inverter I/O allocation byte number from the Configurator.
 - Basic/Standard remote I/O: 4 bytes (both for OUT and IN)
 - Special remote I/O: 4 bytes (both for OUT and IN)
 - Control remote I/O: 8 bytes (both for OUT and IN)

■ Switching via Connection Objects

This method is defined by ODVA AC/DC drive objects. Switching via connection objects is possible only when using a CS1W-DRM21 or CJ1W-DRM21 Master Unit. Set the remote I/O connection path used for the scan list with the Configurator. At communications startup, Slave communications are started from the Master Unit with the connection path set in the scan list.

Connection Objects for Switching Remote I/O Operations

To switch remote I/O operations by this method, the appropriate instance IDs must be set for the connection path in the following connection objects.

- Switching remote I/O inputs (3G3MV to SYSMAC PC):
Produced connection path (Class 05 Hex, Instance 02 Hex, Attribute 14 Hex)
- Switching remote I/O outputs (SYSMAC PC to 3G3MV)
Consumed connection path (Class 05 Hex, Instance 02 Hex, Attribute 16 Hex)

Remote I/O Instance ID

The instances to be set are shown in the following table.

Remote I/O type	Instance ID	
	Inputs (3G3MV to PC)	Outputs (PC to 3G3MV)
Basic remote I/O	70 Dec (46 Hex)	20 Dec (14 Hex)
Standard remote I/O	71 Dec (47 Hex)	21 Dec (15 Hex)
Special remote I/O	150 Dec (96 Hex)	100 Dec (64 Hex)
Control remote I/O	151 Dec (97 Hex)	101 Dec (65 Hex)

Restrictions on Switching Remote I/O

To switch remote I/O operations, maintain either of the following conditions and send an explicit message.

- Remote I/O communications stopped after the remote I/O connection and explicit message connection have been established.
- Remote I/O connection allocated after explicit message connection has been established.

Note 1. With CS1W-DRM21 and CJ1W-DRM21 Master Units, the connection path is automatically set at communications startup.

Note 2. This setting is not possible with CVM1-DRM21-V1 and C200HW-DRM21-V1 Master Units.

Data Setting Example

The set data must be converted to signal segments as defined by DeviceNet and then transferred. For example, when remote I/O inputs are converted to special remote I/O inputs (instance ID: 96 Hex), the set data is as follows:

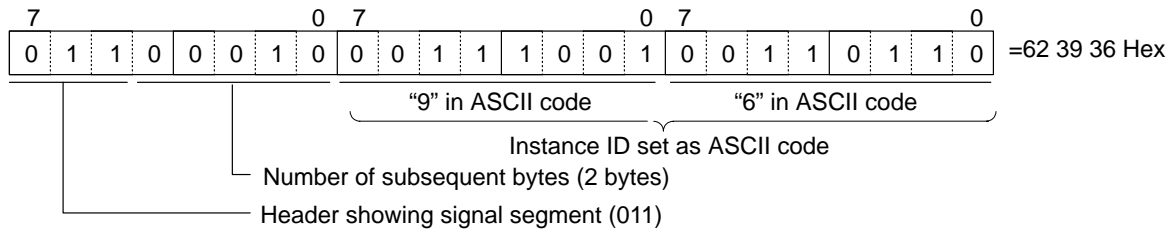

Note For details on using message communications, refer to *5-5 Message Communications (DeviceNet Explicit Messages)* and the operation manual for the Master Unit being used.

5-3 Special Remote I/O Operation

There are four kinds of DeviceNet remote I/O operation: Basic remote I/O, standard remote I/O (the default setting), special remote I/O, and control remote I/O. This section explains special remote I/O. Special remote I/O operation enables using all the functions of 3G3MV Inverters, and setting and reading all parameters. These operations have been developed independently, and are not part of the DeviceNet standard.

5-3-1 Overview of Special Remote I/O

Special remote I/O operations utilize DeviceNet remote I/O, and can directly write to and read from internal Inverter registers. Basically, the register numbers for the various functions shown on this and subsequent pages are specified for writing or reading. Once data has been written, it is retained until it is changed by the next write operation.

■ Words Used for Special Remote I/O

● Outputs (SYSMAC PC to 3G3MV) Instance ID: 100 Dec (64 Hex)

Byte number		Bit 7	Bit 6	Bit 5	Bit 4	Bit 3	Bit 2	Bit 1	Bit 0
Wd n	Rightmost	0	Function code (write/read code)						
	Leftmost	1	Register number leftmost byte (register number allocated to each parameter, etc.)						
Wd n+1	Rightmost	2	Register number rightmost byte (register number allocated to each parameter, etc.)						
	Leftmost	3	Register data leftmost byte (data to write to specified register)						
Wd n+2	Rightmost	4	Register data rightmost byte (data to write to specified register)						

● Outputs (3G3MV to SYSMAC PC) Instance ID: 150 Dec (96 Hex)

		Bit 7	Bit 6	Bit 5	Bit 4	Bit 3	Bit 2	Bit 1	Bit 0
Wd m	Rightmost	0	Function code (returns transmitted code)						
	Leftmost	1	Register number leftmost byte (returns transmitted register number)						
Wd m+1	Rightmost	2	Register number rightmost byte (returns transmitted register number)						
	Leftmost	3	Register data leftmost byte (returns transmitted data amount or reads data)						
Wd m+2	Rightmost	4	Register data rightmost byte (returns transmitted data amount or reads data)						

- Note 1.** Special remote I/O outputs and inputs are paired. When using special remote I/O, be sure to set them together.
- Note 2.** Special remote I/O objects do not conform to the AC/DC drive profile, but are specially set for this product.
- Note 3.** The 16-bit data (register number and register data) is set in two words for each setting.

■ Function Codes

The special remote I/O function codes are shown in the following table. Note that they are different from the explicit message service codes.

Function code (Hex)	Content
10	Data writing
03	Data reading
00	No execution (data wrapping only; no internal processing takes place.)

■ **Setting Data for Operations and Parameters**

Read data and write data to be set for operations and parameters are calculated as shown below and then transmitted in hexadecimal.

- Convert to hexadecimal values with the operation/parameter minimum setting value as 1.
Example: To set a frequency reference of 60 Hz when the minimum setting unit is 0.01 Hz.
 $60/0.01 = 6000 \rightarrow 1770$ Hex
- Negative numbers are expressed as two's complements.
Example: To set a frequency reference bias (n061) of of -100% when the minimum setting unit is 1%:
 $100/1 = 100$ Dec = 0064 Hex, -100% \rightarrow FF9C Hex

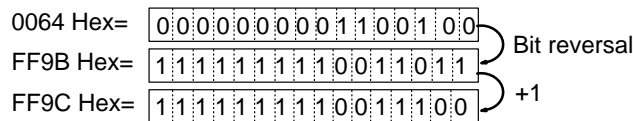

- If the original data is already displayed in hexadecimal, it is transmitted as is.

Note There is nothing corresponding to the parameters for the 3G3MV Inverters.

- Set bits that are not used to "0."
- Do not perform data settings for unused registers.

■ **Storing Parameter Data by Enter Command**

Store the parameter setting data, sent in the way shown in *Setting Data for Operations and Parameters*, in EEPROM by sending an enter command. To store a series of data in more than one parameter, send an enter command after completing all the settings.

Data type	Transmission	Inverter operation	Remarks
Enter command to write to EEPROM	Function code: 10 Hex Register number: FFFD Hex Send data: 0000 Hex	When the enter command is received, the series of parameter setting data will be stored in EEPROM. Note: The maximum number of write operations that can be performed to EEPROM is 100,000 operations.	Used to store data even after power interruption.
Not writing to EEPROM	Enter command not sent.	Previously received parameter setting data is already valid as operating data. If an enter command is not sent, data is not stored in EEPROM.	When there is frequent rewriting of data, do not send an enter command because of problems that arise when writing to EEPROM several times. Be sure to send an enter command once before the power supply is interrupted.

Note Register numbers 0000 to 000F are in RAM only. Even if an enter command is sent for these registers, the data will not be stored in EEPROM.

■ Special Remote I/O Responses

When data is written and read using special remote I/O, the responses shown in the following table are returned. Check that the input data and output data match when handling communications.

Error code	Name	Content	Countermeasure
---	---	Normal completion response The function code and register number at the time of transmission are placed at the beginning, and returned with the data amount (when data is written) or the read data (when data is read) attached.	---
01 Hex	Function code error	A code other than 03 Hex/08 Hex/10 Hex has been set as a function code.	Check and correct the function code.
02 Hex	Register number error	The set register number has not been registered.	Check and correct the register number.
		An attempt to read an enter command register was made.	
21 Hex	Data setting error	An upper or lower limit for the write data setting range was exceeded.	Check the display for the Digital Operator and correct the error data.
		Data that would give rise to an operation error (OPE1 to OPE9) has been erroneously set.	
22 Hex	Writing mode error	During Inverter operations, a write-requested message was received for a parameter that is read-only during operation.	Perform write operations after stopping the Inverter.
		An enter command was received during Inverter operations.	
		A read-requested message was received during UV.	Perform write operations after clearing the UV (main circuit undervoltage) error.
		An enter command was received during UV.	
		During F04 (initial memory error) detection, a write-requested message other than constant initialization (n001="8" or "9"), was received.	After constant initialization (n001 = "8" or "9") has been performed, turn the power supply OFF and ON again.
A write-requested message was received for a read-only register.	Check and correct the register number.		

Note 1. When a communications error occurs, the function code MSB will be returned as "1."

Note 2. A "constant restriction" is a restriction on OPE error detection.

5-3-2 Special Remote I/O Communications Timing

With special remote I/O communications, it is possible to use all of the SYSDRIVE 3G3MV functions, such as frequency setting, control input setting, error monitoring, output frequency monitoring, and so on. These functions are utilized by setting the register numbers and connecting to the various 3G3MV functions. To use these functions properly, be sure to use the following method to handle the data and provide a program for switching the communications processing.

■ **Matching Function Codes and Register Numbers**

- In the remote I/O outputs (SYSMAC PC to 3G3MV), set the function code, register number, and set data for the function to be executed.
- Compare (CMP) the function codes and register numbers of the set remote I/O outputs and the remote I/O inputs (3G3MV to SYSMAC PC). If they agree, proceed to the next process.

Note If data is repeatedly written to the same register number, it cannot be handled. Be sure to keep performing processes with different function codes or register numbers. If it is necessary to write repeatedly to the same register number, then alternately write to and read from that register. (Handling data is made possible by changing function codes.)

■ **Handling Illustration**

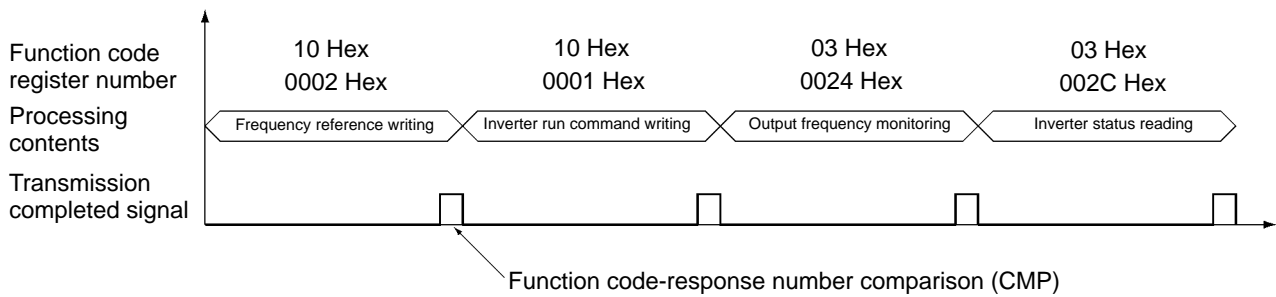

5-3-3 Parameter Register Numbers for Each Function

Refer to 5-6 3G3MV Register Numbers, Classes, Instances, and Attributes.

5-4 Control Remote I/O Operation

There are four kinds of DeviceNet remote I/O operation: Basic remote I/O, standard remote I/O (the default setting), special remote I/O, and control remote I/O. This section explains control remote I/O.

Control remote I/O enables using the functions and arrays of the Inverter control terminal I/O signals. The Inverter’s multi-function I/O functions can be used during communications. These operations have been developed independently, and are not part of the DeviceNet standard.

■ Control Remote I/O

The Control Remote I/O contains functions and arrays matching the Inverter control terminal I/O signals. The Inverter’s multi-function I/O functions can be used during communications.

● Outputs (SYSMAC PC to 3G3MV) Instance ID: 101 Dec (65 Hex)

Byte number		Bit 7	Bit 6	Bit 5	Bit 4	Bit 3	Bit 2	Bit 1	Bit 0	
Wd n	Rightmost	0		Multi-function input 7	Multi-function input 6	Multi-function input 5	Multi-function input 4	Multi-function input 3	Stop/reverse	Stop/forward
	Leftmost	1	Multi-function output 2	Multi-function output 1	Multi-function contact output				Fault reset	External fault input
Wd n+1	Rightmost	2	Frequency reference, rightmost byte							
	Leftmost	3	Frequency reference, leftmost byte							
Wd n+2	Rightmost	4								
	Leftmost	5								
Wd n+3	Rightmost	6								
	Leftmost	7								

● Inputs (3G3MV to SYSMAC PC) Instance ID: 151 Dec (97 Hex)

Byte number		Bit 7	Bit 6	Bit 5	Bit 4	Bit 3	Bit 2	Bit 1	Bit 0	
Wd m	Rightmost	0	Fault	Alarm (minor fault)	Inverter ready	At reference	During re-set input	During reverse run	Zero speed	During run
	Leftmost	1			Multi-function output 2	Multi-function output 1	Multi-function contact output	Local/remote	Undervoltage	Operation fault
Wd m+1	Rightmost	2	Output frequency monitor, rightmost byte							
	Leftmost	3	Output frequency monitor, leftmost byte							
Wd m+2	Rightmost	4	Torque reference monitor, rightmost byte							
	Leftmost	5	Torque reference monitor, leftmost byte							
Wd m+3	Rightmost	6	Output current monitor, rightmost byte							
	Leftmost	7	Output current monitor, leftmost byte							

Note 1. A shaded box indicates that the bit is not used.

Note 2. Control remote I/O inputs and outputs are paired. When using control remote I/O, be sure to set them together.

Note 3. Control remote I/O objects do not conform to the AC/DC drive profile, but are specially set for this product.

● **Word n (Inverter Operation Commands)**

Word	Bit	Signal name	Contents
n	0	Stop/forward	0: Stop 1: Forward
	1	Stop/reverse	0: Stop 1: Reverse
	2	Multi-function input 3 (See note 1.)	0: --- 1: Function set in n050
	3	Multi-function input 4 (See note 1.)	0: --- 1: Function set in n051
	4	Multi-function input 5 (See note 1.)	0: --- 1: Function set in n052
	5	Multi-function input 6 (See note 1.)	0: --- 1: Function set in n053
	6	Multi-function input 7 (See note 1.)	0: --- 1: Function set in n054
	7	Not used	0: --- 1: Function set in n055
	8	External fault input	0: --- 1: External fault (EFO)
	9	Fault reset	0: --- 1: Reset
	10	Not used	---
	11	Not used	---
	12	Not used	---
	13	Multi-function contact output (See note 2.)	0: OFF (open) 1: ON (closed)
	14	Multi-function output 1 (See note 2.)	0: OFF (open) 1: ON (closed)
15	Multi-function output 2 (See note 2.)	0: OFF (open) 1: ON (closed)	

Note 1. The functions set with parameters n052 to n056 (multi-function inputs 3 to 7) can be controlled with these bits.

Note 2. The settings of these bits are enabled when parameters n057 to n059 (multi-function outputs 1 to 3) are set to 18 (communications output). Output from the control terminal block of the Inverter can be controlled via communications.

● Word m (Inverter Status)

Word	Bit	Signal name	Contents
m	0	During run	0: --- 1: During run
	1	Zero speed	0: --- 1: Zero speed
	2	During reverse run	0: --- 1: During reverse run
	3	During reset input	0: --- 1: During reset input
	4	At reference	0: --- 1: At reference
	5	Inverter ready	0: --- 1: Inverter ready
	6	Alarm (minor fault)	0: --- 1: Alarm
	7	Fault	0: --- 1: Fault
	8	Operation error	0: --- 1: Operation error
	9	Undervoltage	0: --- 1: Undervoltage
	10	Run command selection status	0: --- 1: Communication
	11	Multi-function contact output (See note.)	0: --- 1: Function set in n057
	12	Multi-function output 1 (See note.)	0: --- 1: Function set in n058
	13	Multi-function output 2 (See note.)	0: --- 1: Function set in n059
	14	Not used	---
15	Not used	---	

Note The functions set with parameters n057 to n059 (multi-function outputs 1 to 3) are enabled using these bits.

● Reference Data

Word	Signal name	Content
n+1	Frequency reference	<p>Specifies the Inverter output frequency from communications.</p> <ul style="list-style-type: none"> • Setting unit: 0.01 Hz (See note 1.) • Setting range: 0 to maximum frequency in Hz (See note 2.) <p>Example: To set the frequency reference to 60.00 Hz: $60.00 \text{ Hz} / (0.01 \text{ Hz}) = 6000 \text{ Dec} = 1770 \text{ Hex} \Rightarrow \text{Set as } 1770 \text{ Hex.}$</p>

Note 1. The data setting unit can be changed with n035 (frequency reference setting/display unit).

Note 2. Data that exceeds the upper or lower setting range limits will be considered faulty and ignored by the Inverter, and the previous data will be maintained.

● **Monitor Data**

Word	Signal name	Content
m+1	Output frequency monitor	Gives the frequency being output by the Inverter. <ul style="list-style-type: none"> • Monitor unit: 0.01 Hz (See note 1.) Example: Output frequency when the monitor value is 1388 Hex: $1388 \text{ Hex} = 5000 \text{ Dec} \times (0.1 \text{ Hz}) = 50.00 \text{ Hz}$
m+2	Torque reference monitor	Gives the torque reference value inside the Inverter (See note 2.) <ul style="list-style-type: none"> • Monitor unit: 0.1% (100% is motor rated torque) Example: Torque reference for monitor value of 1F4 Hex: $1F4 \text{ Hex} = 500 \text{ Dec} \times (0.1\%) = 50\% \text{ (relative to motor rated torque)}$
m+3	Output current monitor	Gives the value of the current being output by the Inverter. <ul style="list-style-type: none"> • Monitor unit: 0.1 A Example: Output current for monitor value of A Hex: $A \text{ Hex} = 10 \text{ Dec} \times (0.1 \text{ A}) = 1.0 \text{ A}$

Note 1. The data setting unit can be changed with n035 (frequency reference setting/display unit).

Note 2. The torque reference monitor is valid only if vector control is set.

5-5 Message Communications (DeviceNet Explicit Messages)

There are two types of DeviceNet communications: Remote I/O and message communications. This sections explains DeviceNet Communications Unit message communications. With message communications, specific instructions (SEND, RECV, CMND, and IOWR) are used for reading and writing data between Master and Slave Units.

5-5-1 Overview of Message Communications (Explicit Message Operations)

■ Message Communications Operations

Message communications enable data to be exchanged as required between nodes (i.e., between Masters or between Masters and Slaves) on a DeviceNet Network. For example, the accumulated data from a given PC can be read from another PC, and constants from various Slaves can be changed from a PC. To use message communications, however, both nodes involved in the data exchange must support message communications.

Note When the DeviceNet Communications Unit is used, the RS-422/485 of the Inverter cannot be used for communications.

DeviceNet Master Unit
 CS1W-DRM21
 CJ1W-DRM21
 C200HW-DRM21-V1
 CVM1-DRM21-V1

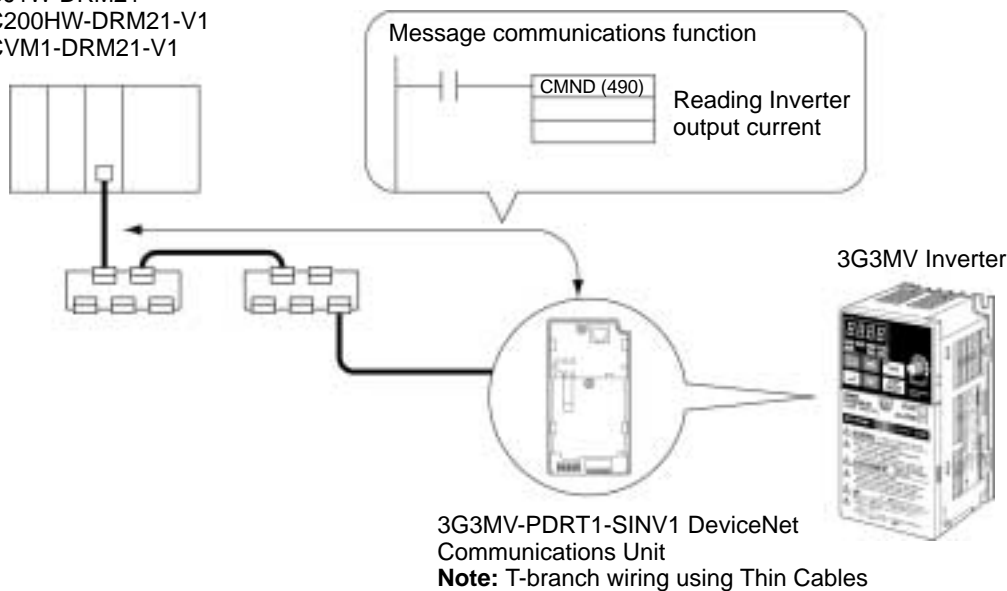

Note When the DeviceNet Communications Unit is used, the RS-422/485 of the Inverter cannot be used for communications.

■ **Types of Message Communications**

DeviceNet message communications are broadly divided into the two categories described below. Of these two categories, the Inverter’s DeviceNet Communications Unit supports explicit messages.

• **Explicit Messages**

Explicit messages are defined by DeviceNet. The class, instance, and attribute are specified for executing message communications. The messages are the same for all Inverter products, so messages can be exchanged in the same way with masters made by other manufacturers.

• **FINS Messages**

Messages can be exchanged using FINS commands between DeviceNet nodes (Masters and Slaves) that support FINS messages. (FINS commands are actually sent and received using DeviceNet explicit messages.)

Note Message communications are supported by CV-series, CS/CJ-series, and C200HX/HG/HE PCs, but not by C200HS PCs.

■ **Overview of Explicit Messages**

Explicit messages are sent and received as described below. Basically explicit message communications are executed in 1-byte (8-bit) units.

Header	Node address	Service code	Class	Instance	Attribute	Data	Footer	
Item	Content							
Header	The header indicates the beginning of an explicit message and that the frame is an explicit message request/response. It is set automatically for DeviceNet, so there is no particular need to be concerned with it.							
Node address	Request: Set the node address of the Slave/Master to be requested. Response: The node address of the responding Slave/Master is set.							
Service code	Request: Set the code of the requested service (read/write, etc.). Response: The MSB (most significant bit) of the requested service code is changed to “1” and returned.							
Class	Function classification (major classification)	Indicates the classification of a function defined by DeviceNet. To specify a function, specify these three codes.						
Instance	Instance classification (minor classification)							
Attribute	Attribute (Set values are assigned for each function.)							
Data	Request: Set the data to be written. Response: Read-requested data or fault message are attached.							
Footer	This is the part that indicates the end of the explicit message and executes the CRC check. It is set automatically for DeviceNet, so there is no particular need to be concerned with it.							

5-5-2 Sending and Receiving Messages with CS1W-DRM21 or CJ1W-DRM21 DeviceNet Unit

■ **Using CMND(194)**

With a CS1W–DRM21 or CJ1W-DRM21 DeviceNet Unit, CMND(490) is used to send explicit messages. To send an explicit message, it is necessary to place FINS command “2801” in front and to send

the command to the Master Unit. The Master Unit that receives the command converts the command data to an explicit message and transfers it to the destination node. When sending an explicit message, it is not possible to directly specify the destination node with CMND(490).

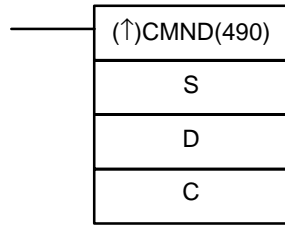

● S: Beginning Command Storage Word

Specify the beginning word address for the command data transferred to the DeviceNet Master Unit. Preset the data to be transferred in consecutive words as shown in the following table.

Word address	Bits	
	15 to 8	7 to 0
S	Command data (Set explicit message FINS command "2801.")	
S+1	Node of Slave or Master for transmission Address: 0 to 3F Hex (0 to 63)	Explicit message service code Write: 10 Read: 0E
S+2	Class ID code (Set DeviceNet class code for relevant function.) Set within 0001 to 002A, or 0064 (Hex) with Inverter's DeviceNet Communications Unit.	
S+3	Instance ID code (Set DeviceNet instance code for relevant function.)	
S+4	Attribute ID code (Set DeviceNet attribute code for relevant function.)	Attached data (for writing)
---	Attached data (for writing)	

● D: Beginning Response Storage Word

Specify the beginning word address of the area for storing responses to messages.

● **C: Beginning Control Code Word**

Specify the beginning word address of the area for storing the required control codes for message communications. The control codes shown in the following table are required by DeviceNet Master Units. Preset the data in consecutive words.

Word address	Bits		
	15	14 to 8	7 to 0
C	Number of command data bytes: 0000 to 00A0 Hex (0 to 160 bytes) Set the amount of data from the beginning S word.		
C+1	Number of response data bytes: 0000 to 00A0 Hex (0 to 160 bytes) Set the size of the data storage area from the beginning D word.		
C+2	Network address: 0001 to 007F Hex (1 to 127) When using CMND(490) with the CS/CJ Series, a network address must be set for each DeviceNet Master Unit. The network address is edited using the routing table edit function of a Peripheral Device (except for the Programming Console).		
C+3	Command destination node address: 00 to 3F Hex (0 to 63) Node address of the Master Unit		Command destination Unit address Set Master Unit (FE) or Master Unit's unit number, 10 to 1F Hex (0 to 15).
C+4	Response	Communications port number: 0 to 7 Set the communications port used for DeviceNet.	Number of retries: 00 to 0F Hex (0 to 15) Set the number of times to resend for error response.
C+5	Response monitor time: 0000 Hex → 2 s 0001 to FFFF Hex → 0.1 to 6553.5 s (unit: 0.1 s) Set at least 2 seconds for explicit messages.		

Note Set “0” in word C+4 bit 15 to require a response or “1” to not require a response. Responses are required for explicit messages, so set “0.”

■ **Message Timing**

When executing CMND(490), an AND condition must be set that requires both the PC's Network Communications Enabled Flag and the Master Unit's Message Communications Enabled Flag to be ON.

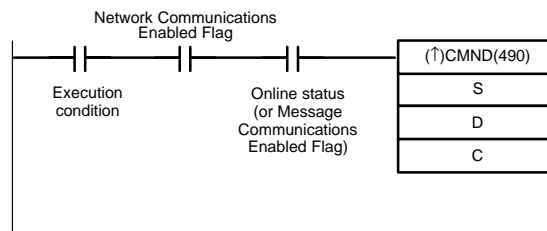

■ **Message Response Read Timing**

Have messages read with the rising edge of the Network Communications Enabled Flag for each communications port.

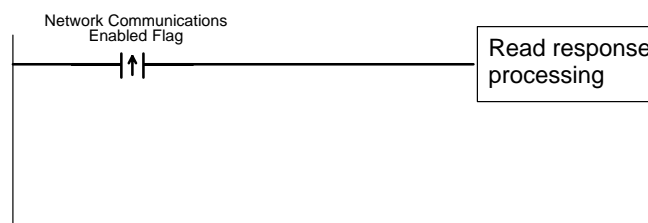

■ Communications Flags

Type	Name	Address		Content
		Word	Bit	
SYSMAC PC flags	Network Communications Enabled Flag	A202	7: Port 7 6: Port 6 5: Port 5 4: Port 4 3: Port 3 2: Port 2 1: Port 1 0: Port 0	0: Execution disabled (executing) 1: Execution enabled (not executing)
	Network Communications Error Flag	A219	15: Port 7 14: Port 6 13: Port 5 12: Port 4 11: Port 3 10: Port 2 9: Port 1 8: Port 0	0: Normal end 1: Abnormal end
Master Unit status flags	Online Flag	25 x Unit number + 1511	00	0: Offline 1: Online
	Message Communications Enabled Flag	25 x Unit number + 1524	12	Indicates the same status as the Online Flag. 0: Offline 1: Online This function is compatible with C200HW-DRM21-V1.

5-5-3 Sending and Receiving Messages with a C200HW-DRM21-V1 DeviceNet Master Unit

■ IOWR for CS1 Series

With a C200HW-DRM21-V1 DeviceNet Master Unit, explicit messages are sent using IOWR. To send an explicit message, it is necessary to place FINS command “2801” in front and to send the command to the Master Unit. The Master Unit that receives the command converts the command data to an explicit message and transfers it to the destination node. (When sending an explicit message, it is not possible to directly specify the destination node with IOWR.)

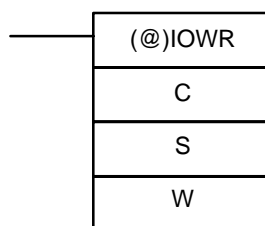

● **C: Control Code**

The control code is set as shown below for DeviceNet Master Units.

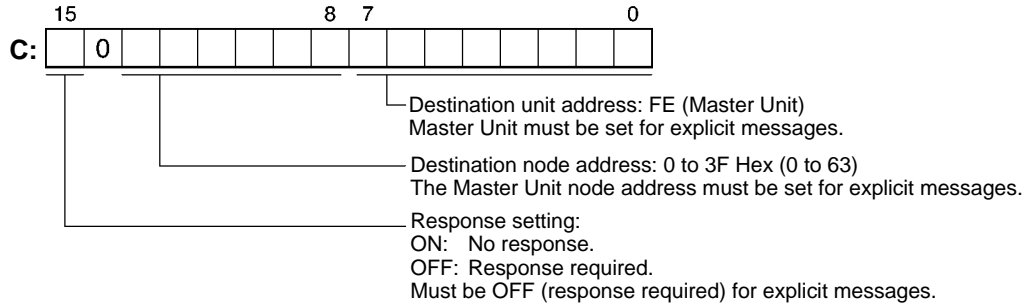

● **S: Beginning Source Word**

Specify the beginning word address for the command data transferred to the DeviceNet Master Unit. Preset the data to be transferred in consecutive words as shown in the following table.

Word address	Bits	
	15 to 8	7 to 0
S	Beginning response storage word Set with the PC's variable area designation method.	
S+1	Example: DM 1000 82 (DM area) 03E8 (1000 in hexadecimal) 00 (fixed at 00 for DM area)	
S+2	Response monitor time: 0000 Hex → 2 s 0001 to 028F Hex → 0.1 to 65.5 s (unit: 0.1 s)	
S+3	Number of command data bytes (Set in hexadecimal.) Note: Command data is the data set in words S+4 onwards.	
S+4	Command data (Set explicit message FINS command "2801.")	
S+5	Node of Slave or Master for transmission Address: 0 to 3F Hex (0 to 63)	Explicit message service code Write: 10 Read: 0E
S+6	Class ID code (Set DeviceNet class code for relevant function.) Set within 0001 to 002A, 0064 (Hex) with Inverter's DeviceNet Communications Unit.	
S+7	Instance ID code (Set DeviceNet instance code for relevant function.)	
S+8	Attribute ID code (Set DeviceNet attribute code for relevant function.)	Attached data (for writing)
---	Attached data (for writing)	

● **W: Number of Words to Transfer/Destination Unit Number**

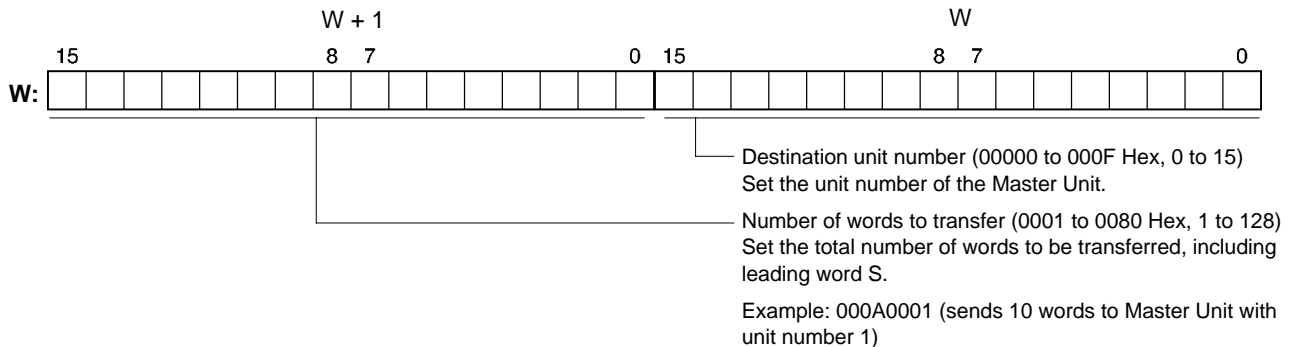

■ IOWR for C200HX/HG/HE

With a C200HW-DRM21-V1 DeviceNet Master Unit, explicit messages are sent using IOWR. To send an explicit message, it is necessary to place FINS command “2801” in front and to send the command to the Master Unit. The Master Unit that receives the command converts the command data to an explicit message and transfers it to the destination node. (When sending an explicit message, it is not possible to directly specify the destination node with IOWR.)

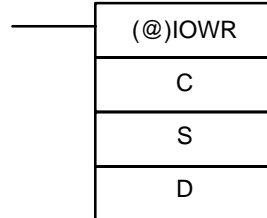

● C: Control Code

The control code is set as shown below for DeviceNet Master Units.

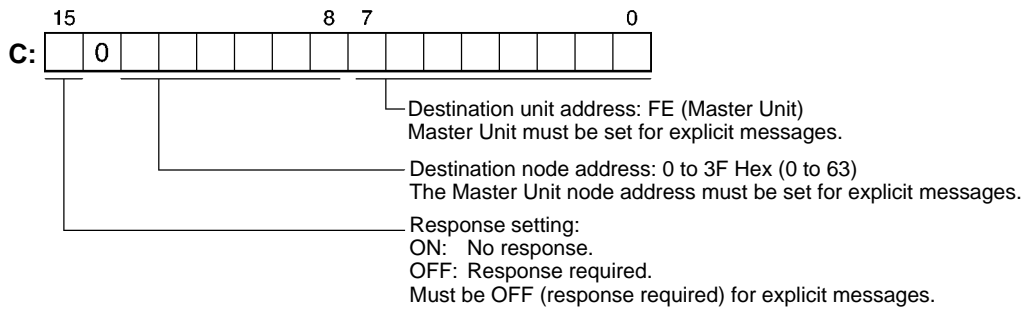

● **S: Beginning Source Word**

Specify the beginning word address for the command data transferred to the DeviceNet Master Unit. Preset the data to be transferred in consecutive words as shown in the following table.

Word address	Bits	
	15 to 8	7 to 0
S	Beginning response storage word Set with the PC's variable area designation method.	
S+1	Example: DM 1000 82 (DM area) 03E8 (1000 in hexadecimal) 00 (fixed at 00 for DM area)	
S+2	Response monitor time: 0000 Hex → 2 s 0001 to 028F Hex → 0.1 to 65.5 s (unit: 0.1 s)	
S+3	Number of command data bytes (Set in hexadecimal.) Note: Command data is the data set in words S+4 onwards.	
S+4	Command data (Set explicit message FINS command "2801.")	
S+5	Node of Slave or Master for transmission Address: 0 to 3F Hex (0 to 63)	Explicit message service code Write: 10 Read: 0E
S+6	Class ID code (Set DeviceNet class code for relevant function.) Set within 0001 to 002A, 0064 (Hex) with Inverter's DeviceNet Communications Unit.	
S+7	Instance ID code (Set DeviceNet instance code for relevant function.)	
S+8	Attribute ID code (Set DeviceNet attribute code for relevant function.)	Attached data (for writing)
---	Attached data (for writing)	

● **D: Destination Information**

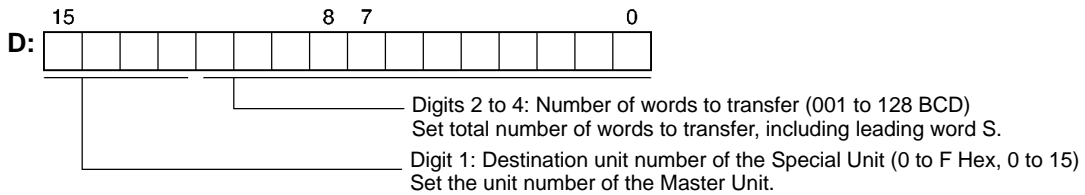

■ **Message Timing**

The Message Communications Enabled Flag must be used as an execution condition for the Master when IOWR is used. Be sure this flag is ON before executing IOWR. If IOWR is executed when this flag is OFF, a Special I/O Unit error may be generated for the Master.

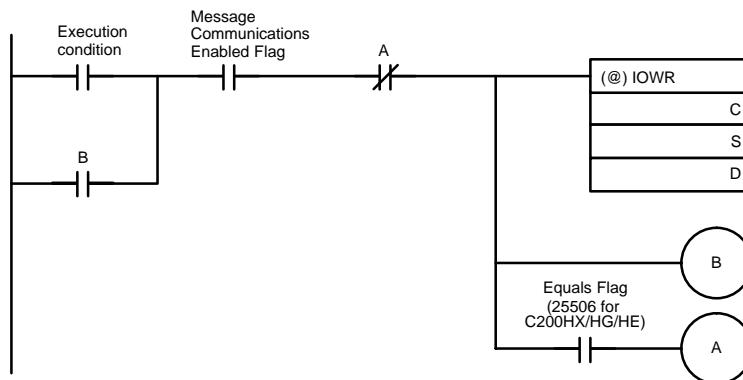

1. IOWR is executed when the execution condition is met and the Message Communications Enabled Flag is ON.
2. When IOWR is executed, it is self-held by bit B.
3. When IOWR is completed, the Equals Flag turns ON and the self-holding bit is cleared.

Note 1. If IOWR ends in an error, the Equals Flag will not turn ON, so the self-holding bit will remain ON.

Note 2. The Equals Flag is also affected by the execution of other instructions, so be careful not to use any other such instructions between IOWR and the Equals Flag.

■ **Timing of Message Response Reading**

Responses are read when the Message Communications Enabled Flag turns ON in the next cycle. The Message Communications Enabled Flag will turn OFF when a Master Unit is executing message communications. If the message response is faster than the PC ladder program cycle time, the Message Communications Enabled Flag will remain ON and response processing will not be possible. Execute the read response processing before IOWR, as shown in the following diagram, and produce a Message Communications Status Flag (d) using bit A.

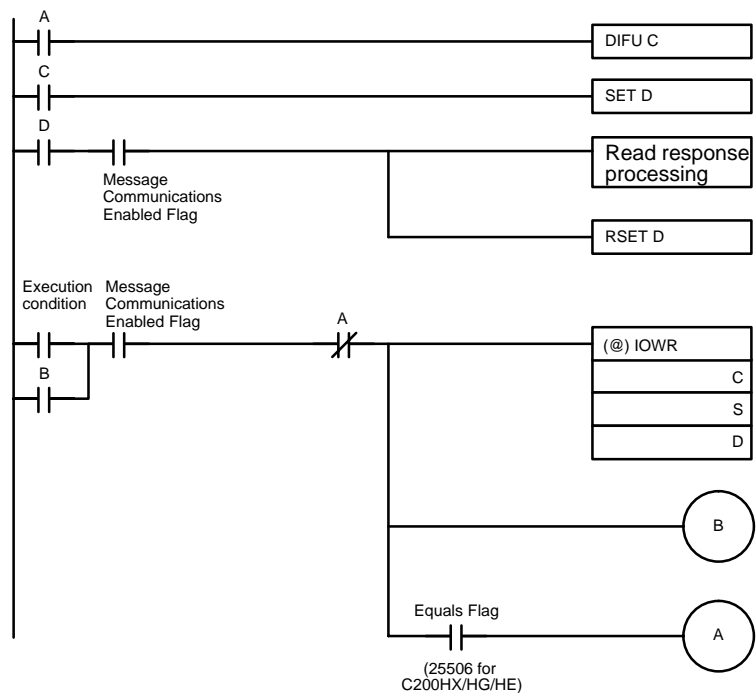

Note If the read response processing is executed after IOWR, there can be no Message Communications Enabled Flag response by means of IOWR, so an attempt could be made to read the response even though the message communications have not been completed.

■ Communications Flags For CS1 Series

Flag	Functions
Equals Flag	The Equals Flag turns OFF when an error occurs in writing a command from the CPU Unit to the Master Unit. This Flag turns ON after a command has been written normally from the CPU Unit to the Master Unit.
Error Flag	The Error Flag is OFF when all operands and the control code are legal. This Flag turns ON when an illegal operand or control code is set or when there is an error in instruction execution.
Message Communications Enabled Flag in the Master Unit status area (bit 12 in CIO 2001 + 10 x unit number)	The Communications Enabled Flag turns OFF during messages communications or when message communications are not possible. This Flag is ON when message communications are possible.

■ Communications Flags For C200HX/HG/HE

Flag	Functions
Equals Flag (SR 25506)	The Equals Flag turns OFF when an error occurs in writing a command from the CPU Unit to the Master Unit. This Flag turns ON after a command has been written normally from the CPU Unit to the Master Unit.
Error Flag (SR25503)	The Error Flag is OFF when all operands and the control code are legal. This Flag turns ON when an illegal operand or control code is set or when there is an error in instruction execution.
Message Communications Enabled Flag in the Master Unit status area (bit 12 in IR 101 + 10 x unit number)	The Communications Enabled Flag turns OFF during messages communications or when message communications are not possible. This Flag is ON when message communications are possible.

5-5-4 CVM1-DRM21-V1 DeviceNet Master Unit Message Transmission

■ Using CMND(194)

With a CVM1-DRM21-V1 DeviceNet Master Unit, CMND(194) is used to send explicit messages. To send an explicit message, it is necessary to place FINS command “2801” in front and to send the command to the Master Unit. The Master Unit that receives the command converts the command data to an explicit message and transfers it to the destination node. When sending an explicit message, it is not possible to directly specify the destination node with CMND(194).



● **S: Beginning Command Storage Word**

Specify the beginning word address for the command data transferred to the DeviceNet Master Unit. Preset the data to be transferred in consecutive words as shown in the following table.

Word address	Bits	
	15 to 8	7 to 0
S	Command data (Set explicit message FINS command "2801.")	
S+1	Node of Slave or Master for transmission Address: 0 to 3F Hex (0 to 63)	Explicit message service code Write: 10 Read: 0E
S+2	Class ID code (Set DeviceNet class code for relevant function.) Set within 0001 to 002A, 0064 (Hex) with Inverter's DeviceNet Communications Unit.	
S+3	Instance ID code (Set DeviceNet instance code for relevant function.)	
S+4	Attribute ID code (Set DeviceNet attribute code for relevant function.)	Attached data (for writing)
---	Attached data (for writing)	

● **D: Beginning Response Storage Word**

Specify the beginning word address of the area for storing responses to messages.

● **C: Beginning Control Code Word**

Specify the beginning word address of the area for storing the required control codes for message communications. The control codes shown in the following table are required by DeviceNet Master Units. Preset the data in consecutive words.

Word address	Bits		
	15	14 to 8	7 to 0
C	Number of command data bytes: 0000 to 00A0 Hex (0 to 160 bytes) Set the amount of data from the beginning S word.		
C+1	Number of response data bytes: 0000 to 00A0 Hex (0 to 160 bytes) Set the size of the data storage area from the beginning D word.		
C+2	Network address: 0001 to 007F Hex (1 to 127) When using CMND(194) with the CV Series, a network address must be set for each DeviceNet Master Unit. The network address is edited using the routing table edit function of a Peripheral Device (except for the Programming Console).		
C+3	Command destination node address: 00 to 3F Hex (0 to 63) Node address of the Master Unit	Command destination Unit address Set Master Unit (FE) or Master Unit's unit number, 10 to 1F Hex (0 to 15).	
C+4	Response	Communications port number: 0 to 7 Set the communications port used for DeviceNet.	Number of retries: 00 to 0F Hex (0 to 15) Set the number of times to resend for error response.
C+5	Response monitor time: 0000 Hex → 2 s 0001 to 028F Hex → 0.1 to 65.5 s (unit: 0.1 s) Set at least 2 seconds for explicit messages.		

Note Set "0" in word C+4 bit 15 to require a response or "1" to not require a response. Responses are required for explicit messages, so set "0."

■ Message Timing

When executing CMND(194), an AND condition must be set that requires both the PC's Network Communications Enabled Flag and the Master Unit's Message Communications Enabled Flag to be ON.

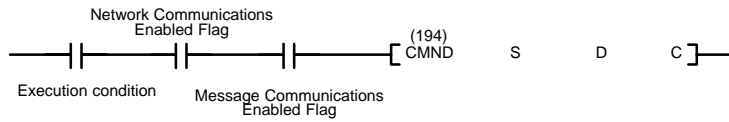

■ Message Response Read Timing

Have messages read with the rising edge of the Network Communications Enabled Flag for each communications port.

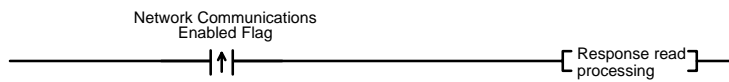

■ Communications Flags

Type	Name	Address		Content
		Word	Bit	
SYSMAC PC flags	Network Communications Enabled Flag	A502	7: Port 7 6: Port 6 5: Port 5 4: Port 4 3: Port 3 2: Port 2 1: Port 1 0: Port 0	0: Execution disabled (executing) 1: Execution enabled (not executing)
	Network Communications Error Flag	A502	15: Port 7 14: Port 6 13: Port 5 12: Port 4 11: Port 3 10: Port 2 9: Port 1 8: Port 0	0: Normal end 1: Abnormal end
Master Unit status flag	Message Communications Enabled Flag	25 x Unit number + 1501	12	0: Communications error detected; Master Unit message communications not possible. 1: Master Unit communications possible.

5-5-5 Overview of Messages and Responses

When message communications are used, the Inverter’s DeviceNet Communications Unit returns responses as explained below.

Basically, DeviceNet communications are executed in 1-byte (8-bit) units. In the case of single-word data (16 bits), the rightmost bits (least significant) and the leftmost bits (most significant) are reversed in order due to the following reasons:

- Data on communications line is transmitted in the order of rightmost bits and leftmost bits.
- Data that is internally processed by PC for issuing commands is transmitted in the order of leftmost bits and rightmost bits.

Therefore, reverse the order for attributes where “Word” is written in the “Size” column in the tables on subsequent pages and create attached data or read response data.

Note There is no need to take this into consideration for remote I/O because the rightmost bits and leftmost bits are automatically reversed.

■ Command Format

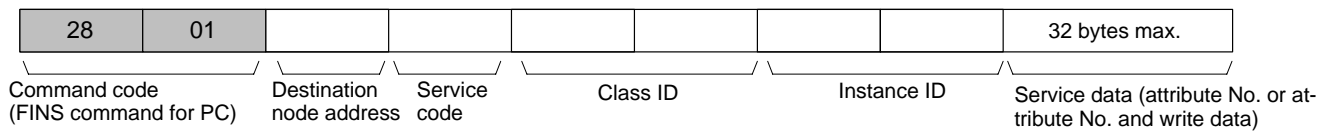

■ Response Format

● Normal Response

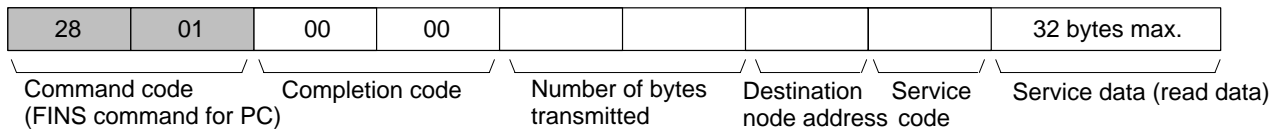

● Error Response

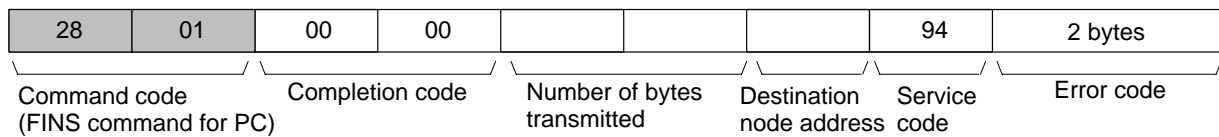

● Failure or Timeout During Transmission

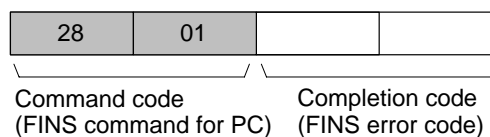

5-5-6 Motor Data Objects: Class 28 Hex

This and subsequent sections provide details on objects. There are eight types of :

- Identify objects (identification information): Class 01 Hex
- Message router objects: Class 02 Hex
- DeviceNet objects: Class 03 Hex
- Assembly objects: Class 04 Hex
- DeviceNet connection objects: Class 05 Hex
- Motor data objects: Class 28 Hex
- Control supervisor objects: Class 29 Hex
- AC/DC drive objects: Class 2A Hex

The three types of objects related to Inverters are the motor data, control supervisor, and AC/DC drive objects. These are explained below and in subsequent sections. The other types of objects are used less frequently, and covered in *8-2 Objects*.

Motor data objects are data and functions related to motors connected to Inverters. The motors that can be connected to Inverters are squirrel-cage inductive motors, so the “Motor Type” is always “7.” The motor’s rated current and rated voltage can be set and read.

■ Support Service Code

Service code number (Hex)	Service
0E	Get attribute single
10	Set attribute single

■ Object Details

Instance	Attribute	Name	Content	Setting range	Default	Read	Write	Size
00	01	Object Software Revision	Indicates class 28 software revisions. The revision value is advanced whenever there is a change.	---	0001	Yes	No	Word
01	03	Motor Type	Indicates the type of motor to be used. The setting for a squirrel-cage inductive motor is 7.	---	07	Yes	No	Byte
	06	Motor Rated Current	The motor’s rated current can be set and read. The setting unit is 0.1 A. (The setting unit can be changed using the current scale in Class 2A, Instance 1, Attribute 17.)	Inverter rated output current 10% to 150%	See note 1.	Yes	Yes	Word
	07	Motor Rated Voltage	The motor’s rated voltage can be set and read. The setting unit is 1 V. (The setting unit can be changed using the voltage scale in Class 2A, Instance 1, Attribute 1B.)	0 to 255 V (0 to 510 V) See note 2.	00C8 (0190) See note 2.	Yes	Yes	Word

Note 1. The default setting for the motor’s rated current depends on the Inverter model.
Example: 1.90A (0013 Hex) for 200-V class, 0.4 kW

Note 2. The figures enclosed in parentheses in the “Setting range” and “Default” columns are the values for 400-V class Inverters.

5-5-7 Control Supervisor Objects: Class 29 Hex

Control supervisor objects are objects that have Inverter control I/O-related functions. They are assigned according to their particular control I/O functions, such as forward operation, reverse operation, error detection, and so on. Be careful when setting up a remote I/O communications connection. These functions are shared with similar functions used for remote I/O, so even if they have been set for message operations they may get rewritten for remote I/O.

■ Support Service Codes

Service code number (Hex)	Service
0E	Get attribute single
10	Set attribute single
05	Reset attribute Turns OFF the Forward Operation and Reverse Operation inputs and turns ON the Fault Reset. Then turns OFF the Fault Reset when Inverter Ready is output.

■ Object Details

Instance	Attribute	Name	Content	Setting range	Default	Read	Write	Size
00	01	Object Software Revision	Indicates class 29 software revisions. The revision value is advanced whenever there is a change.	---	0001	Yes	No	Word
01	03	Forward/Stop	00: Stop 01: Forward operation	00, 01	00	Yes	Yes	Byte
	04	Reverse/Stop	00: Stop 01: Reverse operation	00, 01	00	Yes	Yes	Byte
	05	Net Control Local/remote switch Set note 1.	00: Operate by n003 setting. 01: Operate by DeviceNet with n003 set to "3."	00, 01	00	Yes	Yes	Byte
	06	State Inverter status	03 Hex: Inverter ready	---	03	Yes	No	Byte
	07	During forward run	00: No Inverter output or operating in reverse. 01: Forward operation or DC braking Turns ON even for DC braking during reverse operation.	---	00	Yes	No	Byte
	08	During reverse run	00: No Inverter output or operating in forward. 01: Operating in reverse (reverse operation output status) Becomes "00" with DC braking.	---	00	Yes	No	Byte
	09	Inverter Ready	00: Preparing Initial processing/ not drive mode/ fault 01: Inverter ready Inverter can receive run command.	---	00	Yes	No	Byte
	0A	Fault	00: Normal 01: Fault	---	00	Yes	No	Byte
	0B	Alarm (minor fault)	00: Normal 01: Alarm (minor fault)	---	00	Yes	No	Byte
	0C	Fault Reset	00: Normal status 01: Fault reset	00, 01	00	Yes	Yes	Byte
	0D	Fault code	Indicates the contents of fault that occur. (See the fault code list on the following page.)	---	0000	Yes	No	Word
	0F	Control From Net Run signal input status See note 1.	00: Operating by n003 setting. 01: Operating by DeviceNet.	---	00	Yes	No	Byte
	10	DeviceNet Fault mode See note 2.	02: Maker's specifications	---	02	Yes	No	Byte
	11	Force Fault/Trip Communications external fault input	00: Normal operation 01: Communications external fault input	00, 01	00	Yes	Yes	Byte
12	Force Status Communications external fault input status	00: Normal status 01: Communications external fault detected. (Inverter stopped with fault detection.)	---	00	Yes	No	Byte	

Note 1. The Net Control and Control From Net functions cannot be changed during running.

Note 2. A DeviceNet Fault mode cannot be set from communications. The Inverter will stop when a communications fault is detected.

● **Fault Codes**

DeviceNet error code	Operator display	Meaning
0000	---	Inverter normal
2200	OL2	Inverter overload
2220	OL1	Motor overload
2221	OL3	Overtorque detection 1
2300	OC	Overcurrent
3210	OV	Main circuit overvoltage
3220	UV1	Undervoltage (main)
4200	OH	Overheat
5110	UV2	Control power supply fault
5300	OPR	Operator disconnection
7500	BUS	Communications error
9000	EF3	External fault (Terminal 3)
	EF4	External fault (Terminal 4)
	EF5	External fault (Terminal 5)
	EF6	External fault (Terminal 6)
	EF7	External fault (Terminal 7)
	FF0	Communications external fault

5-5-8 AC/DC Drive Objects: Class 2A Hex

AC/DC drive objects are assigned to command-related functions for drive devices such as Inverters and Servomotors. Command-related data reading and writing, monitor data reading, set data scale changes, and so on, are all enabled. These functions are shared with similar functions used for remote I/O, so even if they have been set for message operations they may get rewritten for remote I/O.

■ Support Service Codes

Service code number (Hex)	Service
0E	Get attribute single
10	Set attribute single

■ Object Details

Instance	Attribute	Name	Content	Setting range	Default	Read	Write	Size
00	01	Object Software Revision	Indicates class 2A software revisions. The revision value is advanced whenever there is a change.	---	0001	Yes	No	Word
01	03	At Reference	00: Stopped, accelerating or decelerating 01: At reference	---	00	Yes	No	Byte
	04	Net Reference (See note 1.)	00: Operate at n004 setting. 01: Set n004 to "3" and operate with DeviceNet.	00, 01	00	Yes	Yes	Byte
	06	Drive Mode	00: Open loop vector (n002 = 1) 01: V/f control (n002 = 0)	00 to 03	01	Yes	Yes	Byte
	07	Speed Actual Rotational Speed Monitor (See note 1.)	Can be referenced in hexadecimal with the output frequency monitor (U-02) minimum unit as 1. The output frequency monitor minimum unit can be set by the frequency reference setting and display units (n035). n035= 0: 0.01 Hz n035= 1: 0.01% (100%: Max. frequency.) n035= 2 to 39: 1 r/min (Set number of poles.) n035= 40 to 39999: Follow individual set values. Setting the attribute 16 speed scale enables a further multiplication factor to be set for n035= 2 to 39: 1 r/min.	---	0000	Yes	No	Word
08	Speed Reference Rotational Speed Reference (See note 1.)	Can be set and read in hexadecimal with the frequency reference minimum unit as 1. The frequency reference minimum unit can be set by the frequency reference setting and display units (n035). n035= 0: 0.01 Hz n035= 1: 0.01% (100%: Max. frequency.) n035= 2 to 39: 1 r/min (Set number of poles.) n035 = 40 to 39999: Follow individual set values. Setting the attribute 16 speed scale enables a further multiplication factor to be set for n035= 2 to 39: 1 r/min.	0 to max. frequency	0000	Yes	Yes	Word	

Instance	Attribute	Name	Content	Setting range	Default	Read	Write	Size
01	09	Current Actual	Can be referenced in hexadecimal with the output current monitor (U-03) minimum unit as 0.1 A. Setting the attribute 17 current scale enables a multiplication factor to be set.	---	0000	Yes	No	Word
	0F	Power Actual	Can be referenced in hexadecimal with the output power monitor (U-11) minimum unit as 1 W. Setting the attribute 1A power scale enables a multiplication factor to be set.	---	0000	Yes	No	Word
	10	Input Voltage	Can be referenced in hexadecimal with the input voltage setting (200 or 400) minimum unit as 1 V. Setting the attribute 1B voltage scale enables a multiplication factor to be set.	---	0000	Yes	No	Word
	11	Output Voltage	Can be referenced in hexadecimal with the output voltage monitor (U-04) minimum unit as 1 V. Setting the attribute 1B voltage scale enables a multiplication factor to be set.	---	0000	Yes	No	Word
	12	Accel Time	Can be set and read in hexadecimal with the acceleration time 1 (n019) and deceleration time 1 (n020) minimum unit as 1 ms. Depending on the acceleration/ deceleration time unit (n018) setting, numbers below 100 ms or 10 ms are truncated.	0.0 to 6,000.0 × 10 ³ ms (0.00 to 600.00 × 10 ³ ms)	2710 Hex (10.0 s)	Yes	Yes	Word
	13	Decel Time	Setting the attribute 1C time scale enables a multiplication factor to be set.		2710 Hex (10.0 s)	Yes	Yes	Word
	14	Low Speed Limit (See note 1 and 3.)	Can be set and read in hexadecimal with the frequency reference lower limit (n034) and the frequency reference upper limit (n033) minimum unit as 1 ms. The minimum unit can be set by the frequency reference setting and display units (n035).	0 to 109% of maximum frequency	0000	Yes	Yes	Word
	15	High Speed Limit (See note 1 and 3.)	n035= 2 to 39: 1 r/min n035= Other than above: 0.1% (Maximum frequency: 100%) Setting the attribute 16 speed scale enables a multiplication factor to be set for n035= 2 to 39: 1 r/min.	0 to 110% of maximum frequency	0708 Hex (1,800 r/min)	Yes	Yes	Word
	16	Speed scale	Speed data unit selection can be set and read. The speed data unit value is calculated as follows: Unit = 1 [r/min] × 1/2 ^a a: Speed scale set value Set a negative value as its 2's complement.	-15 to 15 (F1 to 0F Hex)	00	Yes	Yes	Byte
17	Current scale	Current data unit selection can be set and read. The current data unit value is calculated as follows: Unit = 0.1 [A] × 1/2 ^b b: Current scale set value Set a negative value as its 2's complement.	-15 to 15 (F1 to 0F Hex)	00	Yes	Yes	Byte	

Instance	Attribute	Name	Content	Setting range	Default	Read	Write	Size
01	1A	Power scale	Power data unit selection can be set and read. The power data unit value is calculated as follows: Unit = 0.1 [W] x 1/2 ^c c: Power scale set value Set a negative value as its 2's complement.	-15 to 15 (F1 to 0F Hex)	00	Yes	Yes	Byte
	1B	Voltage scale	Voltage data unit selection can be set and read. The voltage data unit value is calculated as follows: Unit = 0.1 [V] x 1/2 ^d d: Voltage scale set value Set a negative value as its 2's complement.	-15 to 15 (F1 to 0F Hex)	00	Yes	Yes	Byte
	1C	Time scale	Time data unit selection can be set and read. The time data unit value is calculated as follows: Unit = 0.1 [V] x 1/2 ^e e: Voltage scale set value Set a negative value as its 2's complement.	-15 to 15 (F1 to 0F Hex)	00	Yes	Yes	Byte
	1D	Reference From Net	00: Operate at n004 setting. 01: Set B1-01 to "3" and operate with DeviceNet.	---	00	Yes	No	Byte

- Note 1.** The Net Reference and Reference From Net functions cannot be changed during running.
- Note 2.** Under the DeviceNet protocol, the unit for the speed reference is always r/min. The number of motor poles (2 to 39) must be set in parameter n035 (frequency reference setting and display units) when using DeviceNet (open network).
- Note 3.** Cannot be changed during running.

● **Communications Data Setting Examples**

Example 1: Finding the communications data for outputting a frequency of 60 Hz with the following conditions set.

Number of poles (01-03): 4
Speed scale (attribute 16): 0

- Converting frequency to rotational speed:
Frequency x 120 / number of poles = 60 x 120/4 = 1,800 r/min
- Converting rotational speed to minimum unit:
Rotational speed / unit = 1,800 / (1 r/min x 1/2⁰) = 1,800
- Converting communications data to hexadecimal: 1,800 (Dec) = 708 (Hex)

Example 2: Finding the communications data for outputting a frequency of 60 Hz with the following condition set.

Frequency setting (01-03): 0 (Cannot be set with DeviceNet protocol.)

- Converting frequency to minimum setting unit:
Frequency / minimum unit = 60 / 0.01 = 6,000
- Converting communications data to hexadecimal: 6,000 (Dec) = 1,770 (Hex)

Note With frequency, the speed scale has no effect.

Example 3: Finding the communications data for setting a one-minute acceleration time with the following condition set.

Time scale (attribute 1C): -3

- Matching the acceleration time unit: 1 minute = 60 seconds = 60,000 ms
- Converting acceleration time to minimum unit:
Acceleration time / unit = $60,000 / (1 \text{ ms} \times 1/2^{-3}) = 7,500$
- Converting communications data to hexadecimal: 7,500 (Dec) = 1D4C (Hex)

• Communications Data Reference Example

In this example, the hexadecimal value BB8 that has been read is converted to frequency with the following conditions set.

Number of poles (01-03): 4

Speed scale (attribute 16): 1

- Converting communications data to decimal: BB8 (Hex) = 3,000 (Dec)
- Converting from minimum unit to r/min:
Communications data x unit = $3,000 \times (1 \text{ r/min} \times 1/2^1) = 1,500 \text{ (r/min)}$

5-5-9 Reading and Writing Parameters: Class 64 Hex

Inverter parameters can be read and written using explicit messages. Class 100 Dec (64 Hex) has been provided with instances and attributes corresponding to each parameter in the Inverter. Send an explicit message to the class, instance, or attribute of the parameter to be set as described below.

■ Parameter Database

All parameters in the parameter database have been unified to 1-word (16-bit) data. Even settings of 0 and 1 will be treated as 1-word (16-bit) data in explicit messages.

Note When sending or receiving 1-word (16-bit) data in an explicit message, the leftmost and rightmost bytes will be reversed. Accordingly, when reading or writing data, the attribute value will be in the upper byte, the lower byte will contain the lower byte of the data, and the upper byte of the data will be in the upper byte of the next word.

- Communications line data is sent and received in the order of lower byte, then upper byte.
- PLC internal processing data, such as when sending commands, are sent and received in the order of upper byte, then lower byte.

■ Parameter Read and Write Data

Read data and write data for parameters is calculated as shown below and then transmitted in hexadecimal.

- Convert to hexadecimal values with the function/parameter minimum setting unit taken as 1.
Example: To set a frequency reference of 60 Hz when the minimum setting unit is 0.01 Hz.
 $60/0.01 = 6000 \rightarrow 1770 \text{ Hex}$

- Negative numbers are expressed as two's complements.
 Example: To set a frequency reference bias (n061) of -100% when the minimum setting unit is 1%:
 $100/1 = 100 \text{ Dec} = 0064 \text{ Hex}$, $-100\% \rightarrow \text{FF9C Hex}$

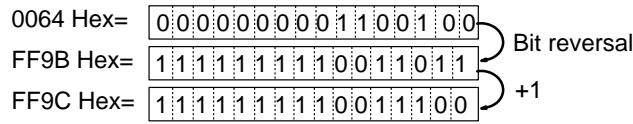

- If the original data is already in hexadecimal, it is transmitted as is.

Note All parameters in the 3G3MV Series are originally in decimal, so convert them to hexadecimal.

- Set bits that are not used to "0."
- Do not set data for unused registers.

■ Storing Parameter Data Using the ENTER Command

To store the parameter data received in EEPROM, send an ENTER command as shown in the following table. To store a series of data for more than one parameter, send an ENTER command after completing all the settings.

Data type	Transmission	Inverter Operation	Remarks
ENTER command to write to EEPROM	Class: 100 Dec (64 Hex) Instance: 255 Dec (FF Hex) Attribute: 253 Hex (FD Hex)	Previously received parameter setting data is stored in EEPROM. Note: The maximum number of write operations that can be performed to EEPROM is 100,000.	Used to store data even after a power interruption.
Not writing to EEPROM	ENTER command not sent.	Previously received parameter setting data is already validated as operating data. Send ENTER command only if storing to EEPROM.	If there is frequent rewriting of data, do not send ENTER commands each time because of the limit to the number of times EEPROM can be written. Be sure to send an ENTER command once before the power supply is interrupted.

■ Parameter Classes, Instances, and Attributes

Refer to 5-6 3G3MV Register Numbers, Classes, Instances, and Attributes.

5-6 3G3MV Register Numbers, Classes, Instances, and Attributes

5-6-1 Inputting Control/Frequency

The Inverter’s various control inputs are allocated to the registers shown in the following table. For example, to set the frequency reference and begin operation, first set the reference value to the frequency reference register “0002,” and then write the run command to the Inverter’s run command register “0001.”

Note 1. Set values are retained until changed by the next writing operation.

Note 2. The following registers are in RAM, so they are all cleared to zero when the Inverter’s power supply is turned OFF.

Register number (Hex)	Function	Content
0000	Not used	---
0001	Run command	Refer to the following <i>Run Commands</i> table.
0002	Frequency reference	Frequency reference value setting (units as specified in n035)
0003	V/f gain	Make settings with 1000 Dec as 100%. (See note 1.) Setting range: 2.0 to 200.0% (20 to 2000 Dec)
0004 to 0008	Not used.	---
0009	Inverter output	Refer to following <i>Inverter Outputs</i> table.
000A to 000F	Not used	---

Note 1. The V/f gain is the setting for the percentage of the V/f calculation result with respect to the output voltage. A setting of 1000 Dec (03E8 Hex) corresponds to a multiplication factor of 1.

Note 2. When these registers are read, the values set in communications will be read. For example, when an operation command (register number 0001) is read, the control input previously set in communications will be returned. It is not a monitor for the actual terminal block input signals.

• Run Commands: Register Number 0001 Hex

Bit	Content
0	Forward/stop (1: forward operation)
1	Reverse/stop (1: reverse operation)
2	Multi-function input 3 (set with n052)
3	Multi-function input 4 (set with n053)
4	Multi-function input 5 (set with n054)
5	Multi-function input 6 (set with n055)
6	Multi-function input 7 (set with n056)
7	Not used.
8	External fault input (1: EFO)
9	Fault reset (1: reset)
10 to 15	Not used.

Note Input from the control terminal block of the Inverter and input from communications have an OR relationship. For this reason, if multi-function input is set to Forward/Stop or Reverse/Stop, it is possible to give run commands by operating the multi-function input for these registers. However, this would create 2 systems of commands and is therefore not recommended.

● **Inverter Outputs: Register Number 0009 Hex**

Bit	Content
0	Multi-function contact output (1: ON)
1	Multi-function output 1 (1: ON)
2	Multi-function output 2 (1: ON)
3 to 15	Not used.

Note Valid when “18” (communications output) is set for multiple-function outputs 1 to 3 (n057 to n059). By performing this setting, the relevant output terminal can be turned ON and OFF through communications.

5-6-2 Inverter Monitoring Functions

All Inverter monitoring can be accessed. To read Inverter status, fault monitoring, alarm monitoring, I/O status monitoring, error log, etc., specify the register number from the following table and read the data.

Register number (Hex)	Function	Content
0020	Status signal	Refer to the following <i>Status Signals</i> table.
0021	Fault status	Refer to the following <i>Fault Status</i> table.
0022	Data link status	Refer to the following <i>Data Link Status</i> table.
0023	Frequency reference	Follows setting for n035.
0024	Output frequency	Follows setting for n035.
0025 to 0027	Not used.	---
0028	Output voltage	Read with 1 (V) = 1 Dec.
0029	Fault status 2	Refer to the following <i>Fault Status 2</i> table
002A	Warning status	Refer to the following <i>Warning Status</i> table
002B	Input terminal status	Refer to the following <i>Input Terminal Status</i> table.
002C	Inverter status	Refer to the following <i>Inverter Status</i> table.
002D	Output terminal status	Refer to the following <i>Output Terminal Status</i> table.
002E	Inverter status 2	Refer to the following <i>Inverter Status 2</i> table
002F to 0030	Not used.	---
0031	Main circuit DC voltage	Read with 1 (V) = 1 Dec.
0032	Torque reference	Read with 1 (%) = 1 Dec. Rated motor torque = 100%. Read with +/-.
0033 to 0034	Not used	---
0035	Accumulated operating time	Read with 1 (h) = 1 Dec.
0036	Not used	---
0037	Output power	Read with 1 (W) = 100 Dec. Read with +/-.
0038	PID feedback	Read with 1 (%) = 10 Dec. Maximum frequency corresponds to 100%.
0039	PID input	Read with 1 (%) = 10 Dec. Maximum frequency corresponds to 100%. Read with +/-.
003A	PID output	Read with 1 (%) = 10 Dec. Maximum frequency corresponds to 100%. Read with +/-.
003B	Output current	Read with 1 (A) = 10 Dec. Read with +/-
003C	Not used.	---
003D	Communications error content	Refer to the following <i>Communications Error Content</i> table.
003E to 00FF	Not used.	---

● **Status Signals: Register Number 0020 Hex**

Bit	Function
0	During RUN (1: during RUN)
1	Forward/reverse operation (1: reverse operation)
2	Inverter ready (1: ready)
3	Fault (1: fault)
4	Data setting error (1: error)
5	Multi-function output 1 (1: ON)
6	Multi-function output 2 (1: ON)
7	Multi-function output 3 (1: ON)
8 to 15	Not used.

● **Fault Status: Register Number 0021 Hex**

Bit	Function
0	OC
1	OV
2	OL2
3	OH
4	Not used.
5	Not used.
6	FBL
7	EF□, STP
8	F□
9	OL1
10	OL3
11	Not used.
12	UV1
13	UV2
14	CE
15	OPR

Note If an error is generated, the relevant bit will become 1.

● **Data Link Status: Register Number 0022 Hex**

Bit	Function
0	During data write (1: during write)
1 to 2	Not used.
3	Upper/lower limit error (1: error): setting range exceeded
4	Integration error (1: error): same as OPE□
5 to 15	Not used.

● **Fault Status 2: Register Number 0029 Hex**

Bit	Function
0	SC
1	GF
2	PF
3	LF
4 to 15	Not used.

● **Warning Status: Register Number 002A Hex**

Bit	Function
0	STP (Operator stop)
1	SER
2	EF
3	BB
4	OL3
5	OH
6	OV
7	UV
8	FAN
9	CE
10	BUS
11	Not used.
12	OH3
13	FBL
14	STP (Emergency stop)
15	Not used.

● **Input Terminal Status: Register Number 002B Hex**

Bit	Function
0	Multi-function input 1 terminal S1 (1: ON)
1	Multi-function input 2 terminal S2 (1: ON)
2	Multi-function input 3 terminal S3 (1: ON)
3	Multi-function input 4 terminal S4 (1: ON)
4	Multi-function input 5 terminal S5 (1: ON)
5	Multi-function input 6 terminal S6 (1: ON)
6	Multi-function input 7 terminal S7 (1: ON)
7 to 15	Not used.

● **Inverter Status: Register Number 002C Hex**

Bit	Function
0	During RUN (1: during RUN)
1	Zero speed (1: zero speed)
2	Frequency agree (1: frequency agree)
3	Warning (minor fault) (1: alarm)
4	Frequency detection 1 (1: output frequency ≤ n095)
5	Frequency detection 2 (1: output frequency ≥ n095)
6	Inverter ready (1: ready)
7	UV (1: UV)
8	Baseblock (1: during baseblock)
9	Frequency reference mode (1: not communications)
10	RUN command mode (1: not communications)
11	Overtorque detection (1: over torque detection)
12	Not used.
13	Fault retry (1: fault retry)
14	Fault (1: fault)
15	Communications timeout: over 2 s without normal communications (1: communications timeout detected)

● **Output Terminal Status: Register Number 002D Hex**

Bit	Function
0	Multi-function contact output terminal MA (1: ON)
1	Multi-function photocoupler output 1 terminal P1 (1: ON)
2	Multi-function photocoupler output 2 terminal P2 (1: ON)
3 to 15	Not used.

● **Inverter Status 2: Register Number 002E Hex**

Bit	Function
0	Frequency reference loss (1: loss)
1 to 15	Not used.

● **Communications Error Content: Register Number 003D Hex**

Bit	Function
0	CRC error (1: error)
1	Incorrect data length (1: error)
2	Not used.
3	Parity error (1: error)
4	Overflow error (1: error)
5	Framing error (1: error)
6	Communications timeout (1: error)
7 to 15	Not used.

5-6-3 Parameter Reading and Writing

The following tables show the SYSDRIVE 3G3MV Inverter parameter classes, instances and attributes, and the corresponding register numbers. Write and read the various parameters with “1” as the minimum setting unit. Negative numbers are expressed as two’s complements. When parameters are written, the settings for parameters that can be written during operation become valid after the being set in RAM, whereas the settings for parameters that cannot be written during operation, become valid from the next operation. Send an enter command to save the set data in EEPROM.

Note The 2 register numbers which are different from RS-422/485 communications are indicated with a “*.”)

■ Function Group 1

Constant	Register number (Hex)	Class 64 (Hex)		Name	Setting range	Setting unit	Default setting	Write during operation
		Instance	Attribute					
n001	0101	01	01	Parameter write-prohibit selection/parameter initialization	0 to 9	1	1	No
n002	0102	01	02	Control mode selection	0, 1	1	0	No
n003	0103	01	03	Run command selection	0 to 3	1	0	No
n004	0104	01	04	Frequency reference selection	0 to 9	1	0	No
n005	0105	01	05	Stopping method selection	0, 1	1	0	No
n006	0106	01	06	Reverse rotation-prohibit selection	0, 1	1	0	No
n007	0107	01	07	STOP Key function selection	0, 1	1	0	No
n008	0108	01	08	Frequency reference selection in local mode	0, 1	1	0	No
n009	0109	01	09	Operator frequency setting method selection	0, 1	1	0	No
n010	010A	01	0A	Operation selection at Digital Operator interruption	0, 1	1	0	No
n011	010B	01	0B	Maximum frequency (FMAX)	50.0 to 400.0	0.1 Hz	60.0	No
n012	010C	01	0C	Maximum voltage (VMAX)	0.1 to 255.0 [0.1 to 510.0]	0.1 V	200.0 (400.0)	No
n013	010D	01	0D	Maximum voltage frequency (FA)	0.2 to 400.0	0.1 Hz	60.0	No
n014	010E	01	0E	Middle output frequency (FB)	0.1 to 399.9	0.1 Hz	1.5	No
n015	010F	01	0F	Middle output frequency voltage (VC)	0.1 to 255.0 [0.1 to 510.0]	0.1 V	12.0 (24.0)	No
n016	0110	01	10	Minimum output frequency (FMIN)	0.1 to 10.0	0.1 Hz	1.5	No
n017	0111	01	11	Minimum output frequency voltage (VMIN)	0.1 to 50.0 [0.1 to 100.0]	0.1 V	12.0 (24.0)	No

Constant	Register number (Hex)	Class 64 (Hex)		Name	Setting range	Setting unit	Default setting	Write during operation
		Instance	Attribute					
n018	0112	01	12	Acceleration/Deceleration time setting unit	0, 1	1	0	No
n019	0113	01	13	Acceleration time 1	0.0 to 6000	0.1 s (set with n018)	10.0	Yes
n020	0114	01	14	Deceleration time 1			10.0	Yes
n021	0115	01	15	Acceleration time 2			10.0	Yes
n022	0116	01	16	Deceleration time 2			10.0	Yes
n023	0117	01	17	S-shape acceleration/deceleration characteristic	0 to 3	1	0	No
n024	0118	01	18	Frequency reference 1	0.00 to maximum frequency	0.01 Hz (set with n035)	6.00	Yes
n025	0119	01	19	Frequency reference 2			0.00	Yes
n026	011A	01	1A	Frequency reference 3			0.00	Yes
n027	011B	01	1B	Frequency reference 4			0.00	Yes
n028	011C	01	1C	Frequency reference 5			0.00	Yes
n029	011D	01	1D	Frequency reference 6			0.00	Yes
n030	011E	01	1E	Frequency reference 7			0.00	Yes
n031	011F	01	1F	Frequency reference 8			0.00	Yes
n032	0120	01	20	Inching frequency command			6.00	Yes
n033	0121	01	21	Upper frequency reference limit	0 to 110	1%	100	No
n034	0122	01	22	Lower frequency reference limit	0 to 110	1%	0	No
n035	0123	01	23	Frequency reference setting/display unit selection	0 to 3999	1	0	No
n036	0124	01	24	Rated motor current	0 to 150% of the rated output current	0.1 A	Differs with capacity	No
n037	0125	01	25	Motor protection characteristics	0, 1, 2	1	0	No
n038	0126	01	26	Motor protective time setting	1 to 60	1 min	8	No
n039	0127	01	27	Cooling fan operation	0, 1	1	0	No
n040	0128	01	28	Motor rotation direction selection	0, 1	1	0	No
n041	0129	01	29	Acceleration time 3	0.0 to 6000	0.1 s (set with n018)	10.0	Yes
n042	012A	01	2A	Deceleration time 3			10.0	Yes
n043	012B	01	2B	Acceleration time 4			10.0	Yes
n044	012C	01	2C	Deceleration time 4			10.0	Yes
n045 to n049	---	---	---	Not used.	---	---	---	---

Note [] values indicate those for 400-V-class Inverters.

■ Function Group 2

Constant	Register number (Hex)	Class 64 (Hex)		Name	Setting range	Setting unit	Default setting	Write during operation
		Instance	Attribute					
n050	0132	01	32	Multi-function input 1 (terminal S1)	1 to 27	1	1	No
n051	0133	01	33	Multi-function input 2 (terminal S2)	1 to 27	1	2	No
n052	0134	01	34	Multi-function input 3 (terminal S3)	0 to 27	1	3	No
n053	0135	01	35	Multi-function input 4 (terminal S5)	1 to 27	1	5	No
n054	0136	01	36	Multi-function input 5 (terminal S5)	1 to 27	1	6	No
n055	0137	01	37	Multi-function input 6 (terminal S6)	1 to 27	1	7	No
n056	0138	01	38	Multi-function input 7 (terminal S7)	1 to 27, 34, 35	1	10	No
n057	0139	01	39	Multi-function input 1 (MA/MB-MC)	0 to 21	1	0	No
n058	013A	01	3A	Multi-function input 2 (P1-PC)	0 to 21	1	1	No
n059	013B	01	3B	Multi-function input 3 (P2-PC)	0 to 21	1	2	No
n060	013C	01	3C	Frequency reference gain	0 to 255	1%	100	Yes
n061	013D	01	3D	Frequency reference bias	-100 to 100	1%	0	Yes
n062	013E	01	3E	Analog frequency reference filter time constant	0.00 to 2.00	0.01 s	0.10	Yes
n063	---	---	---	Not used.	---	---	---	---
n064	0140	01	40	Frequency reference loss detection selection	0, 1	1	0	No
n065	0141	01	41	Multi-function analog output type selection	0, 1	1	0	No
n066	0142	01	42	Multi-function analog output	0 to 5 (6)	1	0	No
n067	0143	01	43	Multi-function analog output gain	0.00 to 2.00	0.01	1.00	Yes
n068	0144	01	44	Multi-function analog voltage input gain	-255 to 255	1%	100	Yes
n069	0145	01	45	Multi-function analog voltage input bias	-100 to 100	1%	0	Yes
n070	0146	01	46	Multi-function analog voltage input filter constant	0.00 to 2.00	0.01 s	0.10	Yes

Con-stant	Reg-ister num-ber (Hex)	Class 64 (Hex)		Name	Set-ting range	Set-ting unit	De-fault set-ting	Write dur-ing op-eration
		Instan-ce	At-trib-ute					
n071	0147	01	47	Multi-function analog current input gain	-255 to 255	1%	100	Yes
n072	0148	01	48	Multi-function analog current input bias	-100 to 100	1%	0	Yes
n073	0149	01	49	Multi-function analog current input filter constant	0.00 to 2.00	0.01 s	0.10	Yes
n074	014A	01	4A	Pulse train frequency reference gain	-255 to 255	1%	100	Yes
n075	014B	01	4B	Pulse train frequency reference bias	-100 to 100	1%	0	Yes
n076	014C	01	4C	Pulse train frequency reference input filter constant	0.00 to 2.00	0.01 s	0.10	Yes
n077	014D	01	4D	Multi-function analog input terminal function selection	0 to 4	1	0	No
n078	014E	01	4E	Multi-function analog input terminal selection	0, 1	1	0	No
n079	014F	01	4F	Multi-function analog input frequency bias	0 to 50	1%	10	No

■ Function Group 3

Con-stant	Reg-ister num-ber (Hex)	Class 64 (Hex)		Name	Set-ting range	Set-ting unit	De-fault set-ting	Write dur-ing op-eration
		Instan-ce	At-trib-ute					
n080	0150	01	50	Carrier frequency selection	1 to 4, 7 to 9	1	Differs with capacity.	No
n081	0151	01	51	Momentary power interruption compensation	0, 1, 2	1	0	No
n082	0152	01	52	Number of fault retries	0 to 10	1	0	No
n083	0153	01	53	Jump frequency 1	0.00 to 400.00	0.01 Hz	0.00	No
n084	0154	01	54	Jump frequency 2	0.00 to 400.00		0.00	No
n085	0155	01	55	Jump frequency 3	0.00 to 400.00		0.00	No

Con-stant	Reg-ister num-ber (Hex)	Class 64 (Hex)		Name	Set-ting range	Set-ting unit	De-fault set-ting	Write dur-ing op-eration
		Instan-ce	At-trib-ute					
n086	0156	01	56	Jump width	0.00 to 25.50	0.01 Hz	0.00	No
n087	0157	01	57	Cumulative operation time selection	0, 1	1	0	No
n088	0158	01	58	Cumulative operation time	0 to 6550	1 (10 h)	0	No
n089	0159	01	59	DC injection braking current	0 to 100	1%	50	No
n090	015A	01	5A	DC injection braking-to-stop time	0.0 to 25.5	0.1 s	0.5	No
n091	015B	01	5B	Startup DC injection braking time	0.0 to 25.5	0.1 s	0.0	No
n092	015C	01	5C	Stall prevention during deceleration	0, 1	1	0	No
n093	015D	01	5D	Stall prevention level during accelera-tion	30 to 200	1%	170	No
n094	015E	01	5E	Stall prevention level during operation	30 to 200	1%	160	No
n095	015F	01	5F	Frequency detection level	0.00 to 400.0	0.01 Hz	0.00	No
n096	0160	01	60	Overtorque detection function selection 1	0 to 4	1	0	No
n097	0161	01	61	Overtorque detection function selection 2	0, 1	1	0	No
n098	0162	01	62	Overtorque detection level	30 to 200	1%	160	No
n099	0163	01	63	Overtorque detection time	0.1 to 10.0	0.1 s	0.1	No
n100	0164	01	64	UP/DOWN frequency selection	0, 1	1	0	No
n101	0165	01	65	Speed search deceleration time	0.0 to 10.0	0.15	2.0	No
n102	0166	01	66	Speed search level	0 to 200	1%	150	No
n103	0167	01	67	Torque compensation gain	0.0 to 2.5	0.1	1.0	Yes
n104	0168	01	68	Torque compensation primary delay time constant	0.0 to 25.5	0.1 s	0.3 (0.2)	No
n105	0169	01	69	Torque compensation core loss	0.0 to 6550	0.1 W	Differs with capaci-ty.	No
n106	016A	01	6A	Rated motor slip	0.0 to 20.0	0.1 Hz	Differs with capaci-ty.	Yes

Con-stant	Reg-ister num-ber (Hex)	Class 64 (Hex)		Name	Set-ting range	Set-ting unit	De-fault set-ting	Write dur-ing op-eration
		Instan-ce	At-trib-ute					
n107	016B	01	6B	Motor phase-to-neutral resistance	0.000 to 65.50	0.001 Ω	Differs with capaci-ty.	No
n108	016C	01	6C	Motor leakage inductance	0.00 to 655.0	0.01 mH	Differs with capaci-ty.	No
n109	016D	01	6D	Torque compensation limit	0 to 250	1%	150	No
n110	016E	01	6E	Motor no-load current	0 to 99	1%	Differs with capaci-ty.	No
n111	016F	01	6F	Slip compensation gain	0.0 to 2.5	0.1	0.0 (1.0)	Yes
n112	0170	01	70	Slip compensation primary delay time	0.0 to 25.5	0.1 s	2.0 (0.2)	No
n113	0171	01	71	Slip compensation during regeneration	0, 1	1	0	No
n114	---	---	---	Not used.	---	---	---	---
n115	0173	01	73	Stall prevention level automatic sup-pression selection	1	0, 1	0	No
n116	0174	01	74	Stall prevention acceleration/decelera-tion time setting	1	0, 1	0	No
n117	0175	01	75	Low torque detection selection	0 to 4	1	0	No
n118	0176	01	76	Low torque detection level	0 to 200	1%	10	No
n119	0177	01	77	Low torque detection time	0.1 to 10.0	0.1 s	0.1	No

■ Function Group 4

Con-stant	Regis-ter num-ber (Hex)	Class 64 (Hex)		Name	Set-ting range	Set-ting unit	De-fault setting	Write during op-eration
		Instan-ce	Attrib-ute					
n120	0178	01	78	Frequency reference 9	0.00 to maximum frequency	0.01 Hz (set with n035)	0.00	Yes
n121	0179	01	79	Frequency reference 10			0.00	Yes
n122	017A	01	7A	Frequency reference 11			0.00	Yes
n123	017B	01	7B	Frequency reference 12			0.00	Yes
n124	017C	01	7C	Frequency reference 13			0.00	Yes
n125	017D	01	7D	Frequency reference 14			0.00	Yes
n126	017E	01	7E	Frequency reference 15			0.00	Yes
n127	017F	01	7F	Frequency reference 16			0.00	Yes
n128	01D3*	01	D3	PID control selection	0 to 8	1	0	No

Con-stant	Regis-ter num-ber (Hex)	Class 64 (Hex)		Name	Set-ting range	Set-ting unit	De-fault setting	Write during opera-tion
		Instan-ce	Attrib-ute					
n129	01D4*	01	D4	Feedback value adjustment gain	0.00 to 10.00	0.01	1.00	Yes
n130	0182	01	82	Proportional gain (P)	0.0 to 25.0	0.1	1.0	Yes
n131	0183	01	83	Integral time (I)	0.0 to 360.0	0.1 s	1.0	Yes
n132	0184	01	84	Derivative time (D)	0.00 to 2.50	0.01 s	0.00	Yes
n133	0185	01	85	PID offset adjustment	-100 to 100	1%	0	Yes
n134	0186	01	86	Integral (I) upper limit	0 to 100	1%	100	Yes
n135	0187	01	87	PID primary delay time	0.0 to 10.0	0.1 s	0.0	Yes
n136	0188	01	88	Feedback loss detection selection	0, 1, 2	1	0	No
n137	0189	01	89	Feedback loss detection level	0 to 100	1%	0	No
n138	018A	01	8A	Feedback loss detection time	0.0 to 25.5	0.1 s	1.0	No
n139	018B	01	8B	Energy-saving control selection	0, 1	1	0	No
n140	018C	01	8C	Energy-saving control coefficient K2	0.0 to 6550	0.1	Differs with capacity.	No
n141	018D	01	8D	Energy-saving voltage lower limit at 60-Hz output	0 to 120	1%	50%	No
n142	018E	01	8E	Energy-saving voltage lower limit at 6-Hz output	0 to 25	1%	12%	No
n143	018F	01	8F	Power averaging time	1 to 200	1 (24 ms)	1	No
n144	0190	01	90	Probe operation voltage limit	0 to 100	1%	0%	No
n145	0191	01	91	Probe operation control voltage step at 100%	0.1 to 10.0	0.1%	0.5%	No
n146	0192	01	92	Probe operation control voltage step at 5%	0.1 to 10.0	0.1%	0.2%	No
n147 n148	---	---	---	Not used.	---	---	---	---
n149	0195	01	95	Pulse train input scale	100 to 3300	1 (10 Hz)	2500	No
n150	0196	01	96	Multi-function analog output, pulse train frequency selection	0, 1, 6, 12, 24, 36, 40 to 45	1	0	No
n151	0197	01	97	RS-422/485 communications time-over detection selection	0 to 4	1	0	No

Con-stant	Regis-ter num-ber (Hex)	Class 64 (Hex)		Name	Set-ting range	Set-ting unit	De-fault setting	Write during opera-tion
		Instan-ce	Attrib-ute					
n152	0198	01	98	RS-422/485 communications frequency reference/monitor unit selection	0 to 3	1	0	No
n153	0199	01	99	RS-422/485 communications slave address (read only)	0 to 32	1	0	No
n154	019A	01	9A	RS-422/485 baud rate selection (read only)	0 to 3	1	2	No
n155	019B	01	9B	RS-422/485 parity selection (read only)	0, 1, 2	1	0	No
n156	019C	01	9C	RS-422/485 send wait time (read only)	10 to 65	1 ms	10	No
n157	019D	01	9D	RS-422/485 RTS control selection	0, 1	1	0	No
n158	019E	01	9E	Motor code	0 to 70	1	Differs with capacity.	No
n159	019F	01	9F	Energy-saving voltage upper limit at 60-Hz output	0 to 120	1%	120	No
n160	01A0	01	A0	Energy-saving upper limit voltage at 6-Hz output	0 to 25	1%	16	No
n161	01A1	01	A1	Power detection width for probe operation switching	0 to 100	1%	10%	No
n162	01A2	01	A2	Power detection filter constant	0 to 255	1 (4 ms)	5	No
n163	01A3	01	A3	PID output gain	0.0 to 25.0	0.1	1.0	No
n164	01A4	01	A4	PID feedback input block selection	0 to 5	1	0	No
n165	---	---	---	Not used.	---	---	---	---
n166	01A6	01	A6	Open input phase detection level	0 to 100	1%	0	No
n167	01A7	01	A7	Open input phase detection time	0 to 255	1 s	0	No
n168	01A8	01	A8	Open output phase detection level	0 to 100	1%	0	No
n169	01A9	01	A9	Open output phase detection time	0.0 to 2.0	0.1 s	0.0	No
n170 to n172	---	---	---	Not used.	---	---	---	---
n173	01AD	01	AD	DC injection braking proportional gain	1 to 199	1 (0.001)	83	No
n174	01AE	01	AE	DC injection braking integration time	1 to 250	1 (4 ms)	25	No
n175	01AF	01	AF	Low carrier frequency at low speed	0, 1	1	0	No
n176	01B0	01	B0	Parameter copy and verify function selection (read only)	0 to 5	1	0	Yes

Constant	Register number (Hex)	Class 64 (Hex)		Name	Setting range	Setting unit	Default setting	Write during operation
		Instance	Attribute					
n177	01B1	01	B1	Parameter read prohibit selection (read only)	0, 1	1	0	Yes
n178	01B2	01	B2	Fault log (read only)	---	---	---	---
n179	01B3	01	B3	Software number (read only)	---	---	---	---

Note [] values indicate those for 400-V-class Inverters.

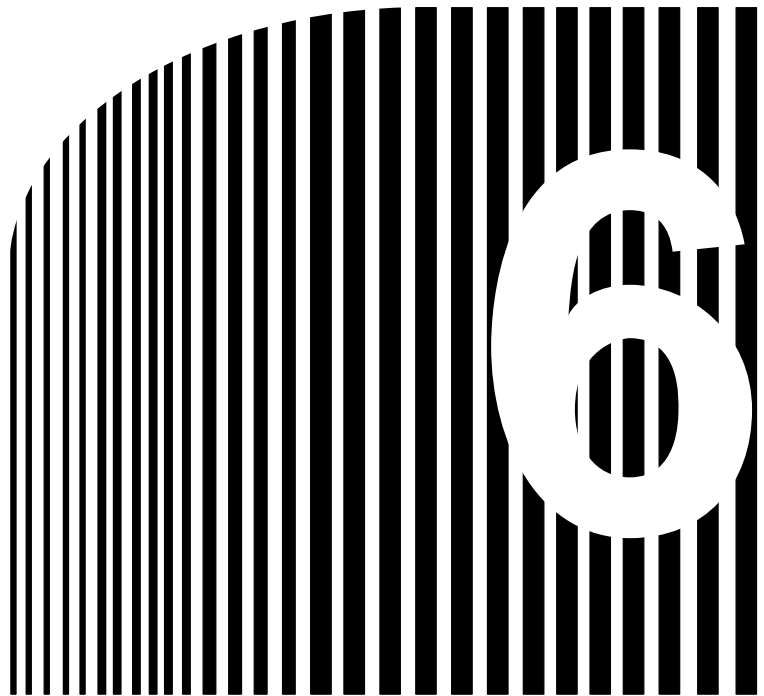

Chapter 6

• Communications Errors •

- 6-1 Communications Line Errors
- 6-2 Message Communications Errors
- 6-3 Special Remote I/O Errors
- 6-4 Inverter Faults

6-1 Communications Line Errors

Malfunctions in DeviceNet communications that are a result of broken wires, short circuits, reversed wiring, duplicate node address assignments, or noise interference are detected as transmission (BUS) errors. When a transmission error is detected, the Inverter's Fault Bit will turn ON and the motor will coast to a stop.

When an error is detected, perform error processing according to the indicator display of the DeviceNet Communications Unit with the terminal cover and Digital Operator removed.

■ Operation Indicators

The DeviceNet Communications Unit has 4 operation indicators that show the status of the power and communications.

Indicator	Display		Meaning	Countermeasures
	Color	Status		
PWR	Green	Lit	Power is being supplied from the Inverter to the Unit.	---
	---	Not lit	Power is not being supplied from the Inverter. The Unit is not connected properly and power is not being supplied to it.	Check the Option Unit connector and turn ON the Inverter power supply. Replace the Option Unit.
MS	Green	Lit	The Unit is operating normally.	---
		Flashing	Initial settings or necessary preparations for communications are incomplete.	Turn ON the Inverter power supply again. Replace the Option Unit.
	Red	Lit	A fatal error (hardware error) has occurred in the Unit.	Turn ON the Inverter power supply again. Replace the Option Unit.
		Flashing	A non-fatal error, such as a switch setting error, has occurred.	Check the baud rate setting. Turn ON the Inverter power supply again. Replace the Option Unit.
	---	Not lit	Power is not being supplied from the Inverter. The Unit is not connected properly and power is not being to supplied to it.	Check the Option Unit connector and turn ON the Inverter power supply. Replace the Option Unit.

Indicator	Display		Meaning	Countermeasures
	Color	Status		
NS	Green	Lit	The DeviceNet Network is operating normally. (Communications connections established.)	---
		Flashing	The Network is normal, but the communications connection with the Master Unit is not established.	Turn ON the power supply again after the following steps. <ul style="list-style-type: none"> • Register in the scan list. • Turn ON the power supply to the Master Unit.
	Red	Lit	A fatal communications error has occurred. A DeviceNet communications error was detected caused by node address duplication or Bus OFF. (These errors make communications impossible.)	Turn ON the power supply again after the following steps. <ul style="list-style-type: none"> • Correct node address duplication. • Connect termination resistance to both ends of the communications line. • Correct the Master Unit errors that occur when the Master Unit stops after communications is once established. • Correct environmental conditions such as noise.
		Flashing	A non-fatal communications error has occurred due to communications timeout.	Turn ON the power supply again after the following processing. <ul style="list-style-type: none"> • Connect termination resistance to both ends of the communications line. • Correct defective connections in the communications line. • Correct environmental conditions such as noise.
---	Not lit	A DeviceNet Network error has occurred. For example, the Network does not exist, power is not supplied to the Unit, or the baud rates do not match.	Check the baud rate setting. Check the Option Unit connector and turn ON the Inverter power supply. Replace the Option Unit.	

Indicator	Display		Meaning	Countermeasures
	Color	Status		
WD	Green	Flashing	The CPU Unit of the Unit is operating normally.	---
	Red	Lit	The CPU Unit of the Unit is not ready or the CPU Unit has malfunctioned.	Check the Option Unit connector and turn ON the Inverter power supply. Replace the Option Unit.
	---	Not lit	Power is not being supplied from the Inverter. The Unit is not connected properly and power is not being to supplied to it.	Check the Option Unit connector and turn ON the Inverter power supply. Replace the Option Unit.

Note 1. When both of the baud rate setting pins DR0 and DR1 are set to ON, both the MS and NS will be lit in red.

Note 2. For communications line problems, detailed error codes will be displayed on the indicators of the Master Unit. Check the error code and take appropriate countermeasures according to the descriptions in *Chapter 15 Troubleshooting and Maintenance of DeviceNet Operation Manual (W267)*.

6-2 Message Communications Errors

■ Explicit Message Errors

If an explicit message is sent, but communications do not end normally, one of the following error codes will be returned with service code 94. Check the meaning of the error message, and either correct the message or adjust the timing of the message.

Error Code	Meaning	Countermeasures
0000	Normal end response.	---
08FF	The requested service does not exist.	Correct the service code and send the data again.
09FF	An invalid attribute was detected.	Check and correct the attribute values, and send the data again.
0CFF	The requested service cannot be executed in the current object mode or status.	Stop the Inverter and send the data again.
0EFF	A request has been sent to change an attribute that cannot be changed.	Check and correct the service code and attribute values, and send the data again.
13FF	There is insufficient data to execute the service.	Correct the data size and send the data again.
14FF	The attribute for the service does not exist.	Check and correct the service code and attribute values, and send the data again.
15FF	There is too much data to execute the service.	Correct the data size and send the data again.
16FF	The specified object does not exist.	Check and correct the class and instance values, and send the data again.
20FF	The parameters are invalid or the data is outside the range for the requested service.	Check and correct the data setting range, send the data again.
1FFF	Manufacturer fault code.	Stop the Inverter and send the data again. Check and correct the data setting range, send the data again.

6-3 Special Remote I/O Errors

■ **Special Remote I/O Errors**

If each function is not set properly using the special remote I/O, the MSB of the function code will be changed to 1 and one of the following error codes will be returned. Check the meaning of the error message, and either correct the message or adjust the timing of the message.

Error code	Name	Content	Countermeasure
---	---	Normal completion response The function code and register number at the time of transmission are placed at the beginning, and returned with the data amount (when data is written) or the read data (when data is read) attached.	---
01 Hex	Function code error	A code other than 03 Hex/08 Hex//10 Hex has been set as a function code.	Check and correct the function code.
02 Hex	Register number error	The set register number has not been registered.	Check and correct the register number.
		An attempt to read an enter command register was made.	
21 Hex	Data setting error	An upper or lower limit for the write data setting range was exceeded.	Check the display for the Digital Operator and correct the error data.
		Data that would give rise to an operation error (OPE1 to OPE9) has been erroneously set.	
22 Hex	Writing mode error	During Inverter operations, a write-requested message was received for a parameter that is read-only during operation.	Perform write operations after stopping the Inverter.
		An enter command was received during Inverter operations.	
		A read-requested message was received during UV.	Perform write operations after clearing the UV (main circuit undervoltage) error.
		An enter command was received during UV.	
		During F04 (initial memory error) detection, a write-requested message other than constant initialization (n001="8" or "9"), was received.	After constant initialization (n001 = "8" or "9") has been performed, turn the power supply OFF and ON again.
A write-requested message was received for a read-only register.	Check and correct the register number.		

Note The MSB of the function code will be returned as 1 when there is a communications failure.

6-4 Inverter Faults

■ Detecting Inverter Faults

When a fault is detected in the Inverter itself, the status will change as shown in the following table.

Function	Inverter Fault Status
Remote I/O	The fault output allocated in the remote I/O will turn ON. If the fault output is ON, turn OFF all related inputs controlling the Inverter, and program a sequence to stop the program.
Explicit messages	Read the fault output for Class 29, Instance 1, Attribute 0A using message communications. If there is a fault in the Inverter, the fault output will be ON, so turn OFF all related inputs controlling the Inverter, and program a sequence to stop the program.
Special remote I/O	Read register 002C, and check whether bit 14 (fault output) is ON (serious fault). If bit 14 is ON, turn OFF all related inputs controlling the Inverter, and program a sequence to stop the program.

■ Confirming Inverter Fault Status

The fault information for the Inverter can be checked by using the following methods. Perform troubleshooting based on the information corresponding to the fault and refer to maintenance information in the *SYSDRIVE 3G3MV Multi-function General-purpose Inverter User's Manual (I527)*.

Function	Inverter Error Status
Operation indicators on Inverter	When there is an Inverter fault, the details will be displayed on the Digital Operator of the Inverter. The fault log can be checked using the monitor function (U-09).
Explicit messages	Read the fault code for Class 29, Instance 1, Attribute 0D using message communications. The code corresponding to the Inverter fault is specified.
Special remote I/O	Read registers 0021. Check the fault status from the bit signals that are output for an Inverter fault.

■ Memory Data Backup (F04)

The SYSDRIVE 3G3MV Inverter uses EEPROM for the data backup. Data is written to EEPROM when the parameters change or the power is turned OFF.

- Data can be written to EEPROM up to 100,000 times.
- Parameters are always written to EEPROM when they are changed using DeviceNet communications, so limit the times that parameters are written to EEPROM as much as possible. (With the special I/O, data will be written to EEPROM when an enter command is received.)
- Frequency reference and control command (register numbers 0000 to 000F for the special I/O) and the Net Control Bit and Net Reference Bit are not written to RAM or EEPROM. When the power is turned OFF, any specified values are cleared.

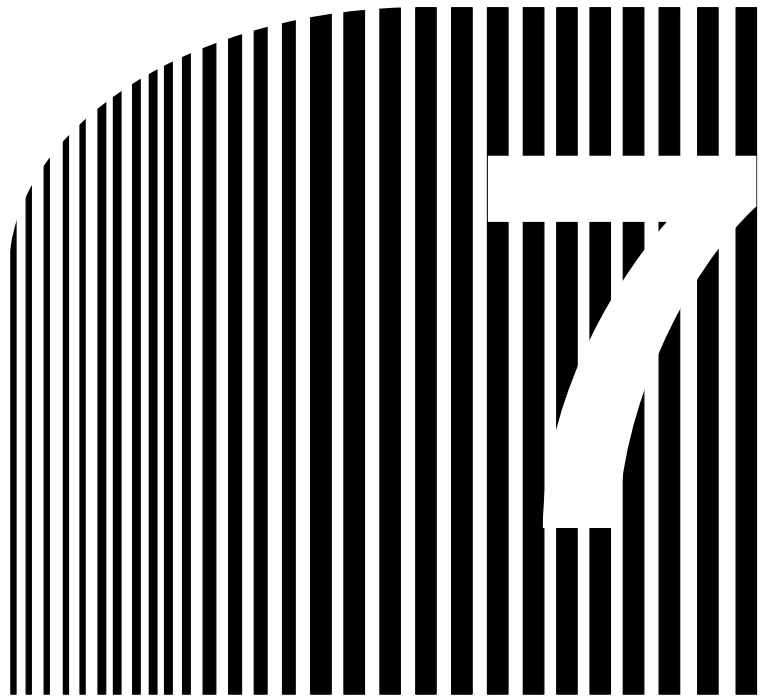

Chapter 7

• **Communications Programs** (SYSMAC CS-series PCs) •

- 7-1 Standard Remote I/O Programming
- 7-2 Message Communications Programming
- 7-3 Special Remote I/O Programs

Note In this chapter, the bits, words, and data memory used in the ladder programs are selected at random. When creating actual programs, modify the contents so that they do not overlap with other areas.

7-1 Standard Remote I/O Programming

When the following standard remote I/O programming is executed, the rotational speed reference data specified in the DM (Data Memory) Area of the PC is written to the 3G3MV Inverter and forward or reverse operation is performed at the specified frequency when the Frequency Reference Input Bit is turned ON and the Forward Input Bit or Reverse Input Bit is turned ON.

■ Allocations

Bit	000000	← Frequency Reference Input Bit
Bit	000001	← Forward Input Bit
Bit	000002	← Reverse Input Bit
Bit	000003	← Fault Reset Input Bit
Bit	000004	← Local/Network selection Bit
Bit	003000	← Fault Flag
	D00000	← Rotational speed reference data

● Remote I/O: Outputs from PC to 3G3MV Inverter

Words n and n + 1

Byte		Bit 7	Bit 6	Bit 5	Bit 4	Bit 3	Bit 2	Bit 1	Bit 0
n	Rightmost	0	---	Net Reference	Net Control	---	---	Fault Reset	Reverse/ Stop
	Leftmost	1	---	---	---	---	---	---	---
n+1	Rightmost	2	Rotational speed reference data						
	Leftmost	3	Rotational speed reference data						

● Remote I/O: Inputs from 3G3MV Inverter to PC

Words m and m + 1

Byte		Bit 7	Bit 6	Bit 5	Bit 4	Bit 3	Bit 2	Bit 1	Bit 0
m	Rightmost	0	At Frequency	Reference From Net	Control From Net	Inverter Ready	During Reverse Run	During Forward Run	Alarm
	Leftmost	1	---	---	---	---	---	---	---
m+1	Rightmost	2	Rotational speed reference data						
	Leftmost	3	Rotational speed reference data						

■ Timing Chart

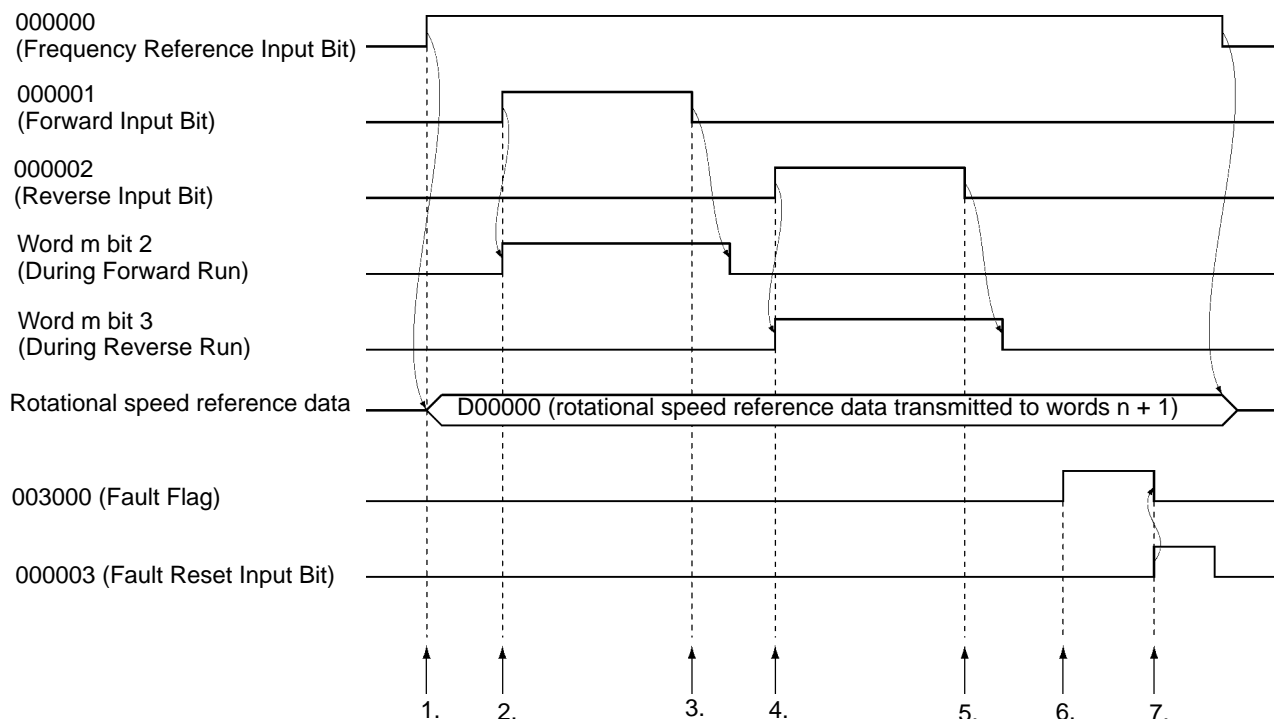

■ Operation

1. When the Frequency Reference Input Bit turns ON, the rotational speed reference data specified in D00000 is moved to remote I/O output word n + 1.
2. When the Forward Input Bit turns ON, remote I/O word n bit 0 (Forward/Stop) will turn ON, and forward operation will start. During forward operation, remote I/O word m bit 2 (During Forward Run) will be ON.
3. When the Forward Input Bit turns OFF, remote I/O word m bit 2 (During Forward Run) will turn OFF after operation will decelerate to a stop.
4. When the Reverse Input Bit turns ON, remote I/O word n bit 1 (Reverse/Stop) will turn ON, and reverse operation will start. During reverse operation, remote I/O word m bit 3 (During Reverse Run) will be ON.
5. When the Reverse Input Bit turns OFF, remote I/O word m bit 3 (During Reverse Run) will turn OFF after operation decelerates to a stop.
6. When the remote I/O Fault Bit (word m bit 0) turns ON, the Fault Flag will turn ON.
7. When the Fault Reset Input Bit turns ON, remote I/O word n bit 2 (Fault Reset Input Bit) will turn ON, and the fault will be cleared. When the fault is reset, the Fault Flag will turn OFF simultaneously.

■ Ladder Program

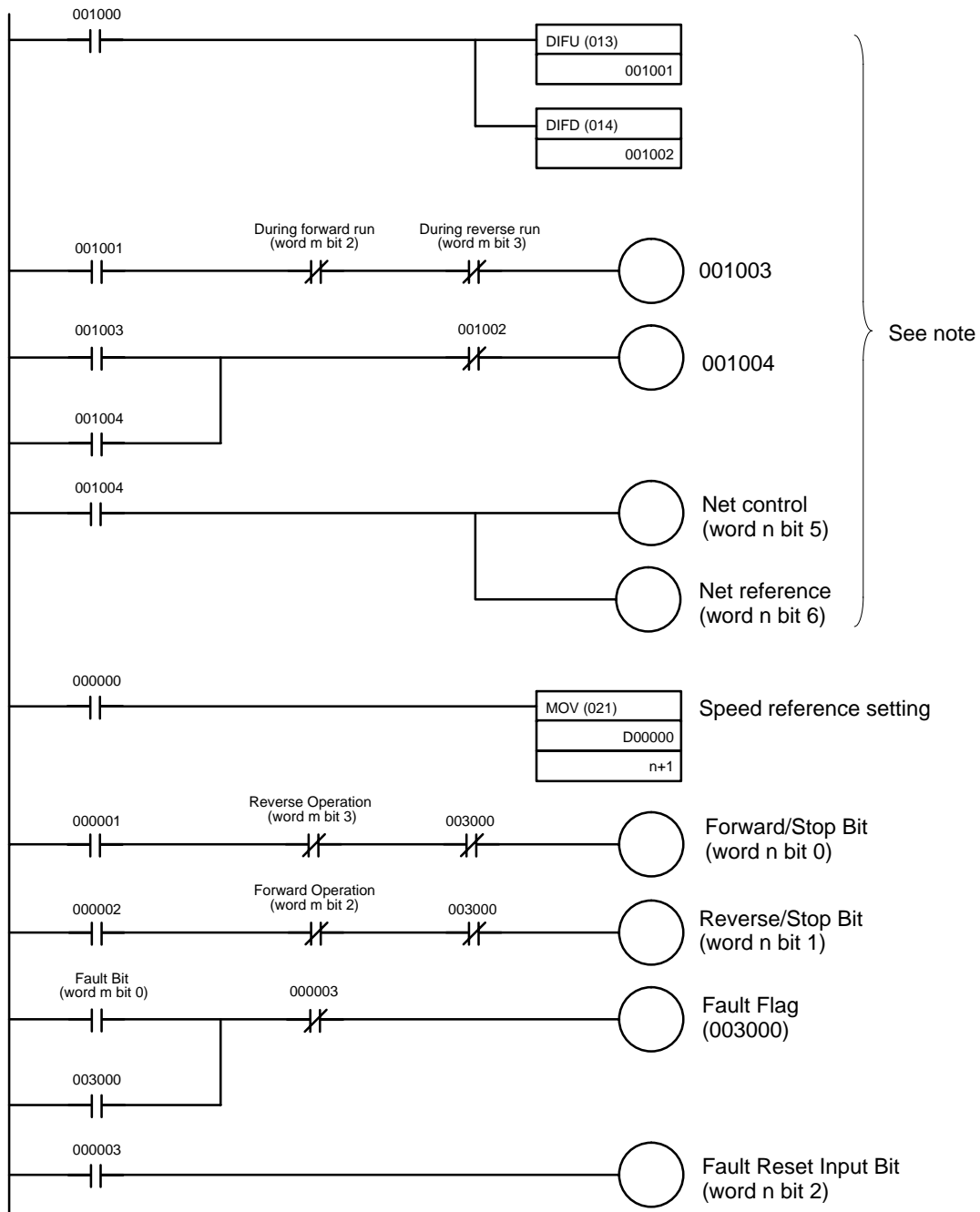

Note This program is used to switch the input method for operation commands and frequency references. It is not required if the n004 (Frequency Reference Selection) is set to "9" and n003 (Inverter Run Command Selection) is set to "3."

7-2 Message Communications Programming

7-2-1 Inverter Fault Processing

The message communications programming example given here reads and stores the fault data using explicit messages for fault outputs from the Inverter. If the Inverter has a fault, the remote I/O input's Fault Bit (word m bit 0) will turn ON. Be sure to turn OFF the Run Command Bits (word n bits 0 and 1). In this program example, the fault code is stored in D00200.

If commands are interrupted by faults, store the completion code in the DM Area and re-execute the command. When a fault occurs, check the contents of the fault and take countermeasures referring to information provided in the *SYS DRIVE 3G3MV Multi-function Compact Inverter User's Manual (I527)*.

■ Allocations

Bit	003000	← Fault Flag
Bit	000000	← Fault Code Read Flag
Bit	000001	← CMND Write Completed Flag
Bit	000002	← Response Flag
Bit	003003	← Sending Message Flag
Bit	003002	← Message Sent Flag
Bit	000100	← Reset Input Bit
	D00000	← Slave node address (3G3MV Inverter)

Response data storage area

Bit	D03000	← Command code: 2801
Bit	D03001	← Completion code
Bit	D03002	← No. of received data bytes
Bit	D03003	← Node address and service code (8E: Read normal; 94: Error)
Bit	D03004	← Read data or error code
Bit	D00100	← Completion code storage for communications errors
Bit	D00200	← Fault code storage for Inverter faults

■ Timing Chart

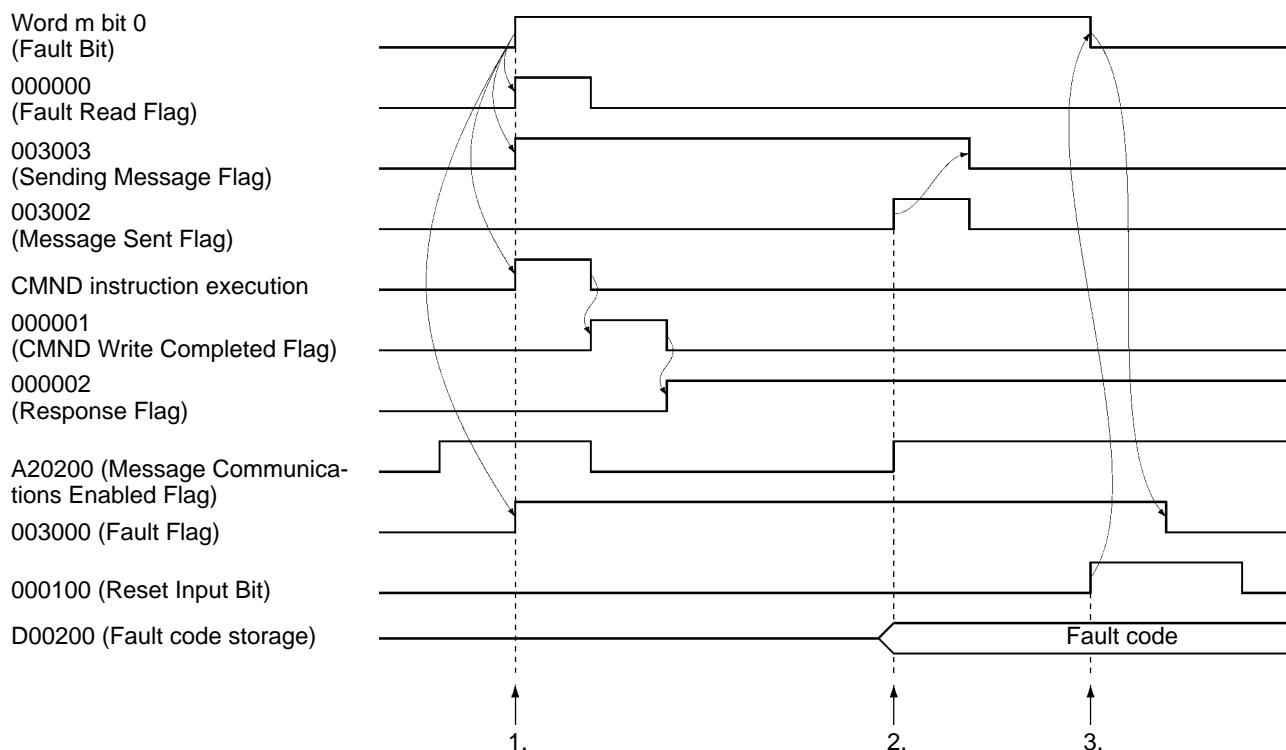

■ Operation

1. When the Inverter has a fault, bit 0 of word m (Fault Bit) will be turned ON. Until the fault is cleared, the Fault Flag will be ON, and this will cause the Fault Read Flag to be turned ON, and the command specified in the DM Area will be sent using the CMND instruction.
2. When the Message Communications Enabled Flag is turned ON, the completion code (D03001) will be examined. If an error is found, the error code will be stored in D00100 and the command will be re-executed. If normally completed, the fault code will be stored in D00200 and the Message Sent Flag will be turned ON, and the Sending Message Flag will be turned OFF.
3. When the Reset Input Bit is turned ON, bit 2 of word n (Fault Reset Input Bit) will turn ON. When the fault is cleared, the Fault Flag will turn OFF.

■ Network Configuration

This program is based on the following conditions.

Master unit number: 0

Master node address: 63

Fixed allocation area setting: 1

Network Communications Enabled Flag: A20200

Online Flag: 151100

Network Communications Error Flag: A21900

■ Ladder Program

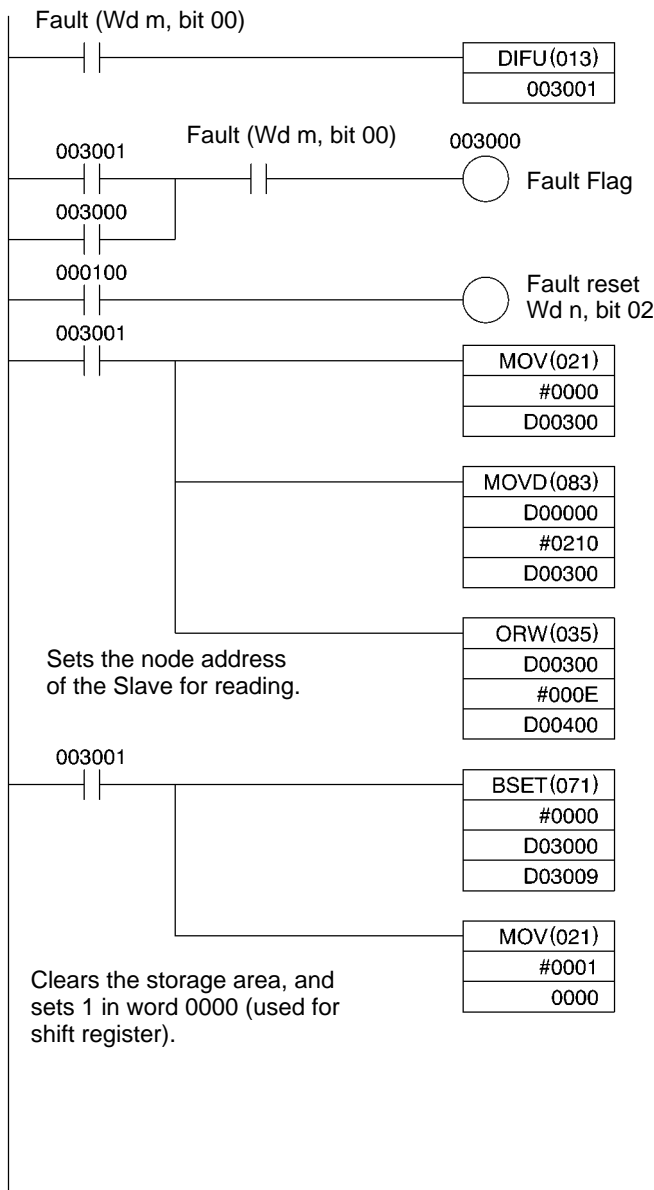

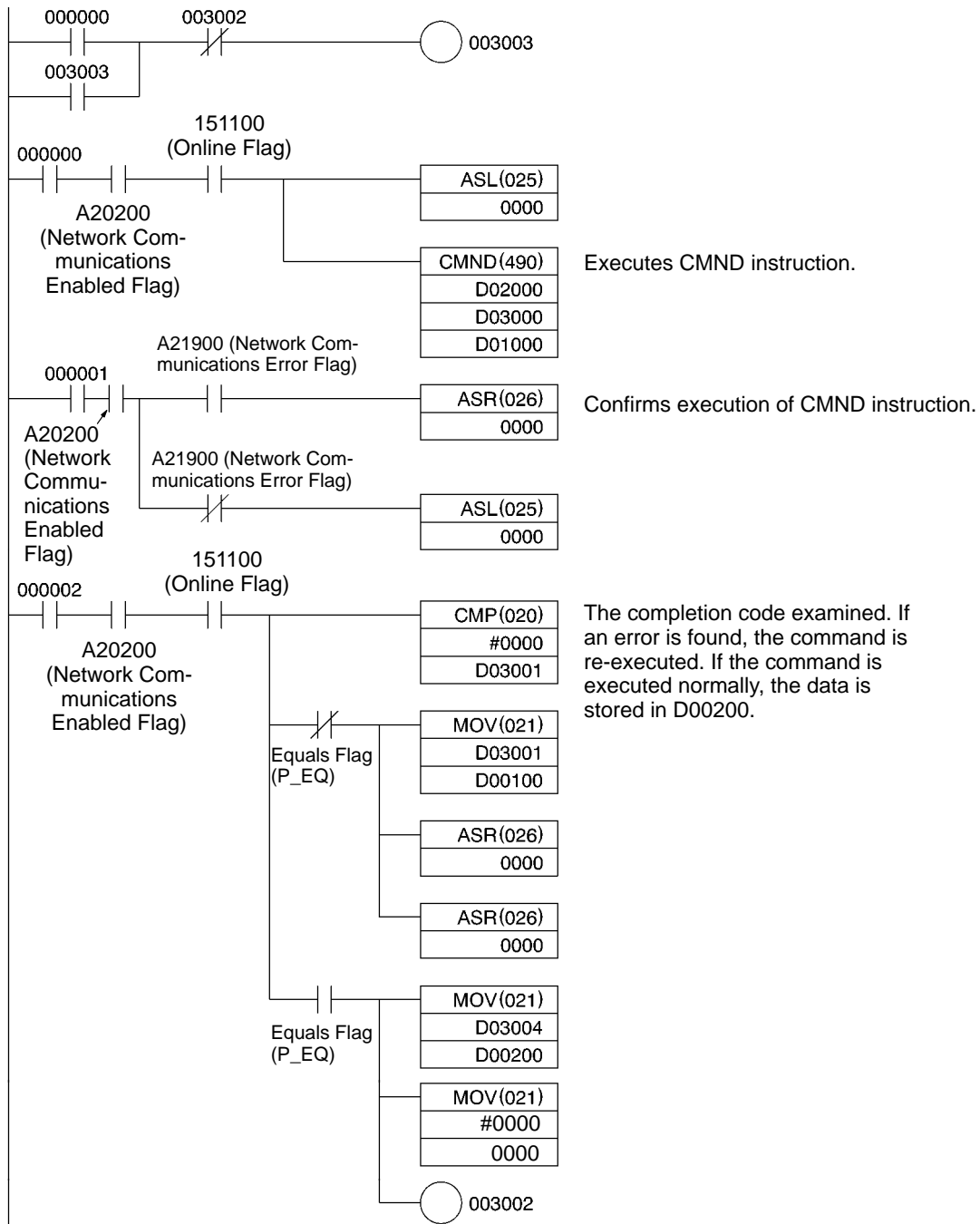

7-2-2 Reading/Writing Data

This programming example writes and reads data using explicit messages. Explicit messages can be executed by specifying FINS commands in the DM Area allocated to the PC, and sending them using the CMND instruction. (The IOWR instruction is used with C200HX/HG/HE PCs.)

If there is an error in the command, the completion code is stored in the DM Area and the command is re-executed.

■ Allocations

Bit	001000	← Program Start Input Bit
Bit	000000	← Message Execution Flag
Bit	000001	← Command Write Flag
Bit	000002	← Response Flag
Bit	003000	← Sending Message Flag
Bit	003001	← Message Sent Flag
	D00000	← Slave node address (3G3MV Inverter)
	D00001	← Service code; 0E: Read, 10: Write
	D00002	← Number of command data bytes (Hex)
	D00003	← Class ID (Hex)
	D00004	← Instance ID (Hex)
	D00005	← Attribute ID (Hex)
	D00006	to D00009 Write data (Hex) (See note)

Note If the written data size is “Word,” set in the order of the rightmost bits and leftmost bits.

Response data storage area

D03000	← Command code: 2801
D03001	← Completion code
D03002	← No. of received data bytes
D03003	← Node address and service code (8E: Read normal; 90: Write normal; 94: Error)
D03004	to D03007 Read data or error code
D00100	Completion code storage for communications errors

■ Timing Chart

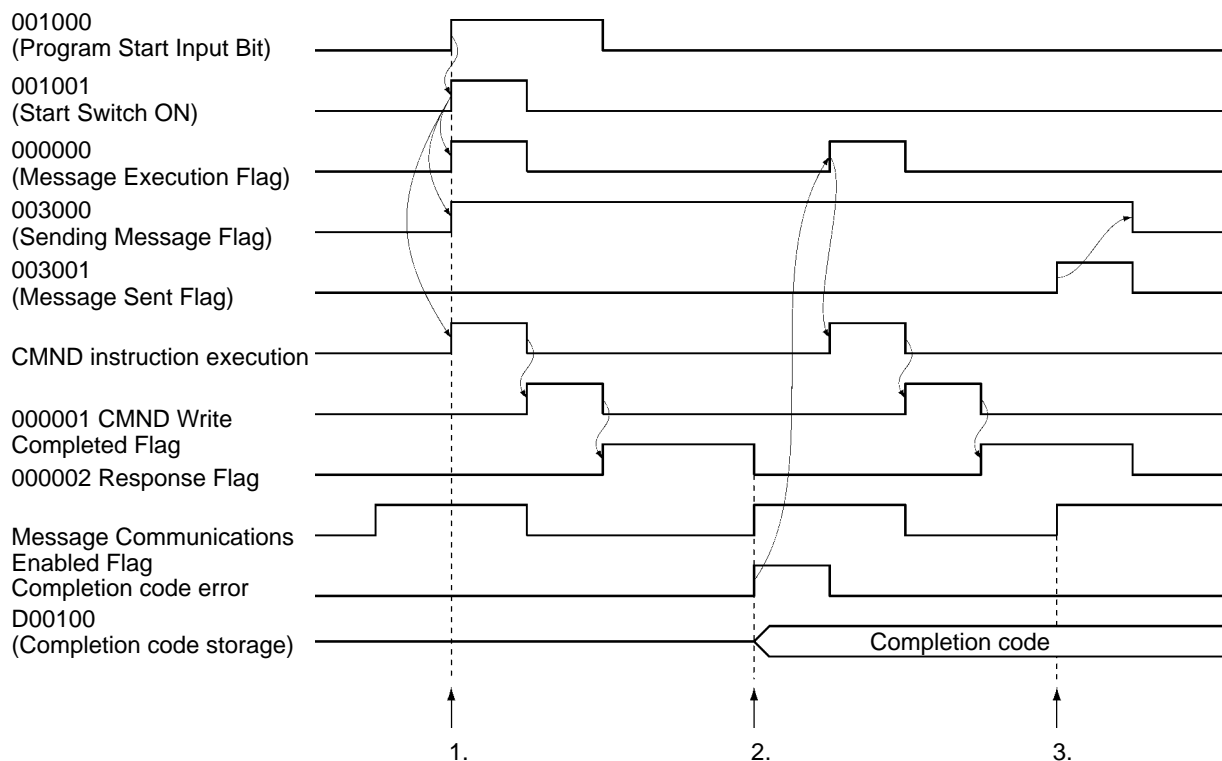

■ Operation

1. When the Program Start Input Bit is turned ON, the Message Execution Flag will turn ON, and the command specified in the DM Area will be sent using the CMND instruction.
2. When the Message Communications Enabled Flag is turned ON, the completion code (D03001) is examined. If an error is found, the completion code is stored in D00100, and the command is re-executed.
3. If the completion code of the response is normal, the Message Sent Flag will be turned ON, and the Sending Message Flag will be turned OFF.

■ Network Configuration

This program is based on the following conditions.

Master unit number: 0

Master node address: 63

Fixed allocation area setting: 1

Network Communications Enabled Flag: A20200

Online Flag: 151100

Network Communications Error Flag: A21900

■ Ladder Program

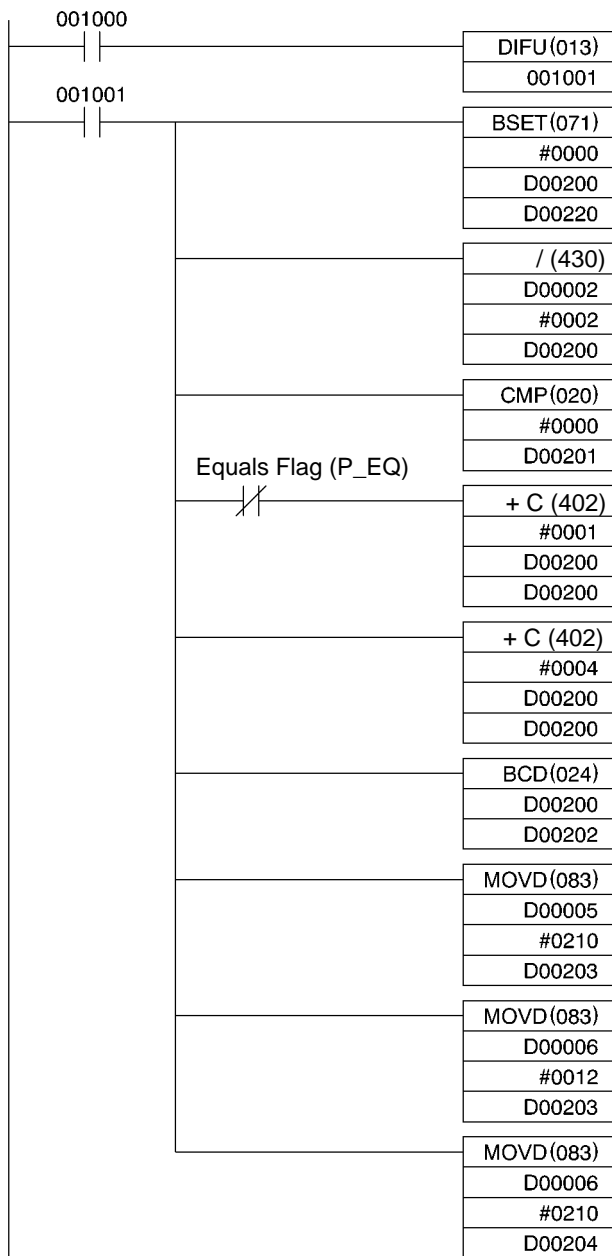

Converts command specified in DM Area to CMND data.

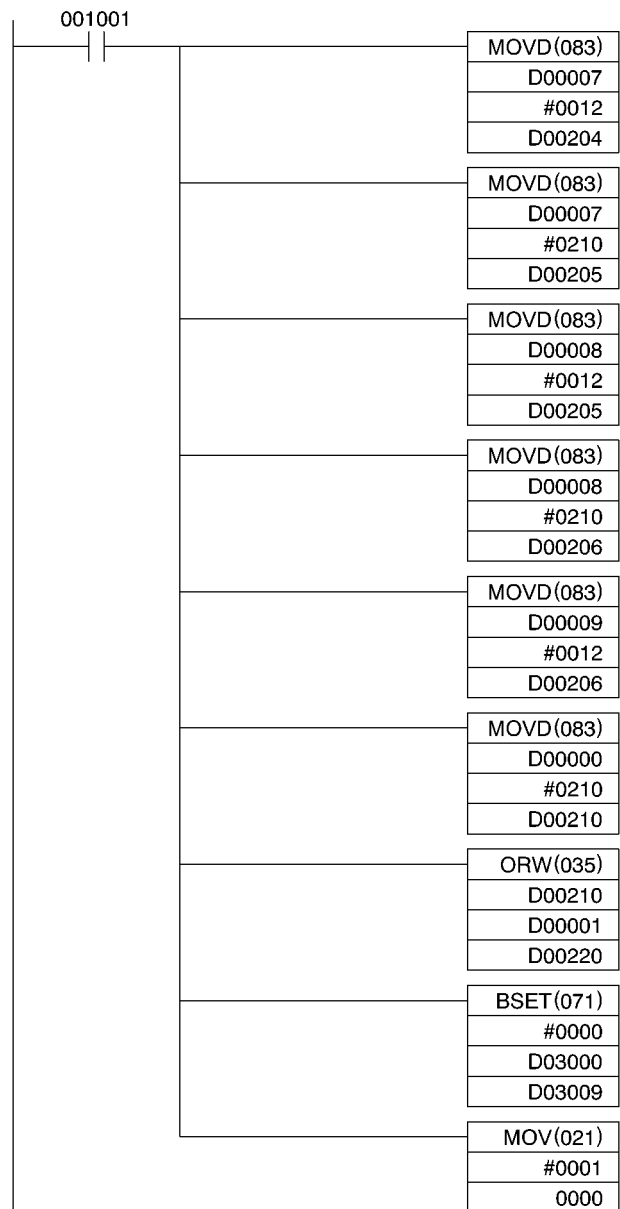

Converts command specified in DM Area to CMND data.

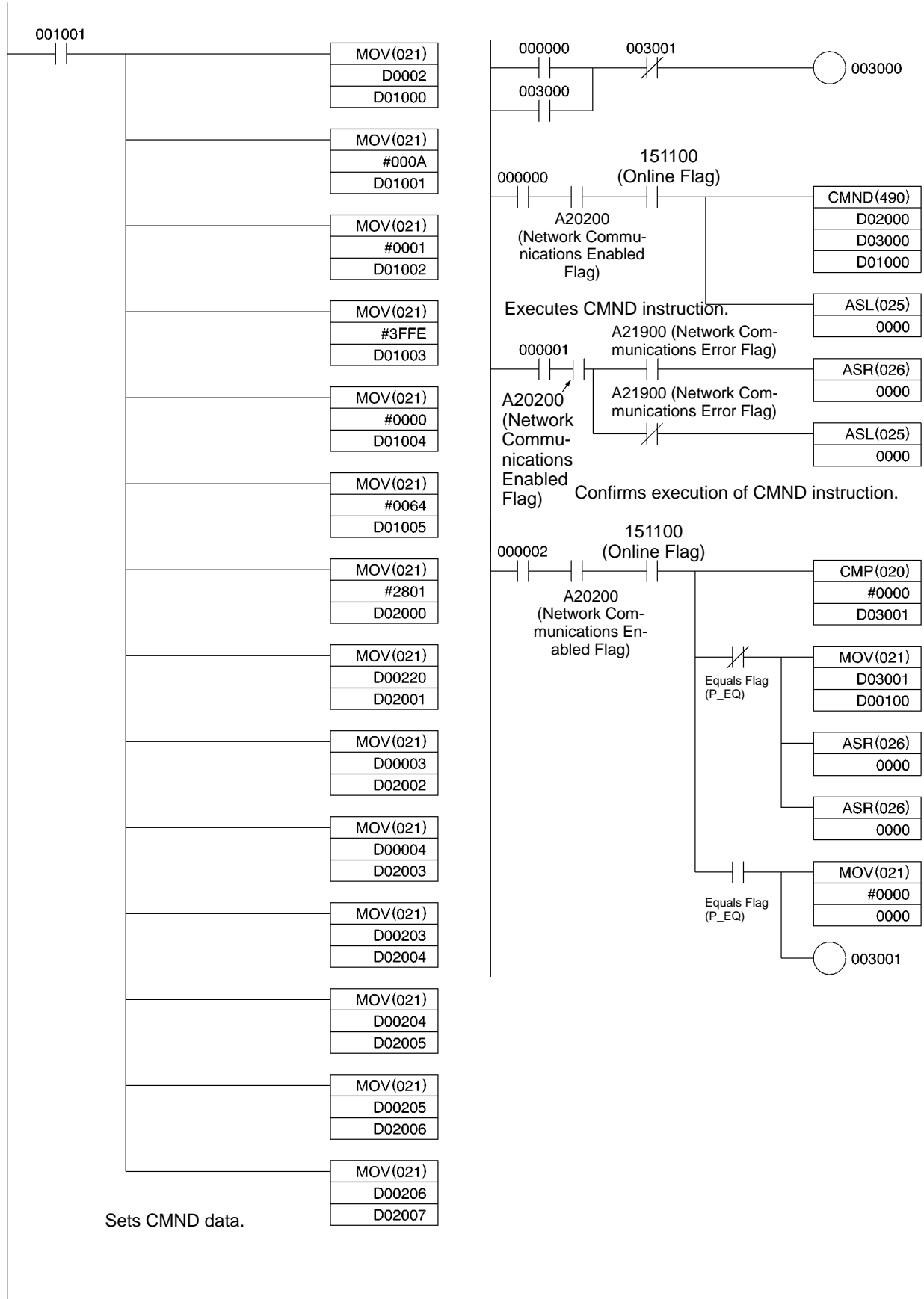

7-3 Special Remote I/O Programs

7-3-1 Simple Operation Programs

This section describes examples of simple operation programming using special remote I/O. To use special remote I/O, it is necessary to switch the remote I/O operation. Refer to 5-2 *Switching Remote I/O Operation* and change to the special remote I/O operation.

Once the Program Start Input Bit is turned ON, Inverter operations will continue until the Program End Input is turned ON. The frequency (speed) reference specified in the DM Area (D01000) of the PC is repeatedly set in the Inverter. The output frequency value will be repeatedly read and stored in the DM Area (D02000). The Inverter status will also be read repeatedly and stored in words (0020**) allocated in the PC.

If any communications error occurs, the program will stop and a stop command will be sent to the Inverter. This state will continue until the Communications Fault Reset Input Bit is turned ON.

Note Write the program so that the Inverter operation commands (001000 and 001001) will be turned OFF when the Fault Bit (002014) of the Inverter status turns ON, and also take appropriate countermeasures according to maintenance information in the *SYSDRIVE 3G3MV Multi-function General-purpose Inverter User's Manual*.

■ Allocations

● Inverter Control Input Word Allocation

Word	Function
001000	Forward/Stop (1: forward) Bit
001001	Reverse/Stop (1: reverse) Bit
001002	Multi-function Input 3 (set with n052) Bit
001003	Multi-function Input 4 (set with n053) Bit
001004	Multi-function Input 5 (set with n054) Bit
001005	Multi-function Input 6 (set with n055) Bit
001006	Multi-function Input 7 (set with n056) Bit
001007	Not used.
001008	External Fault Input (1: EFO) Bit
001009	Fault Reset (1: reset) Bit

● **Inverter Status Word Allocation**

Word	Function
002000	During Run (1: during run) Bit
002001	Zero Speed (1: zero speed) Bit
002002	Frequency Agree (1: frequency agree) Bit
002003	Warning (minor fault) (1: alarm) Bit
002004	Frequency Detect 1 (1: output frequency \leq n095) Bit
002005	Frequency Detect 2 (1: output frequency \geq n095) Bit
002006	Inverter Ready (1: Inverter ready) Bit
002007	UV (1: UV) Bit
002008	Baseblock (1: baseblock) Bit
002009	Frequency Reference Mode (1: not communications) Bit
002010	Run Command Mode (1: not communications) Bit
002011	Overtorque Detection (1: overtorque detected) Bit
002012	Not used.
002013	During Fault Retry (1: during fault retry) Bit
002014	Fault (1: during fault) Bit
002015	Communications Timeover CE (1: communications timeover detected) Bit

● **Program-related Bits Used**

Word	Function
000000	Program Start Input Bit
000001	Program End Input Bit
000002	Program Execution Flag
000003	Communications Error Reset Input Bit
000004	Inverter Stop Command Flag
000100	Frequency Reference Write Flag
000101	Control Input Write Flag
000102	Output Frequency Read Flag
000103	Inverter Status Read Flag
000300	Frequency Reference Write Completed Flag
000301	Control Input Write Completed Flag
000302	Output Frequency Read Completed Flag
000303	Inverter Status Read Completed Flag
003110	Communications Error Flag

● **Inverter Control Input**

Word	Function
D01000	Reference frequency setting
D02000	Output frequency monitor

● Remote I/O Allocation Areas

I/O classification	Word address	15 to 8	7 to 0
Output (PC to 3G3MV Inverter)	n	Register number (leftmost bits)	Function code (10: Write, 03: Read)
	n+1	Register data (leftmost bits)	Register number (rightmost bits)
	n+2	Not used	Register data (rightmost bits)
Input (3G3MV Inverter to PC)	m	Register number (leftmost bits)	Function code (10: Write, 03: Read)
	m+1	Register data (leftmost bits)	Register number (rightmost bits)
	m+2	Not used	Register data (rightmost bits)

■ Timing Chart

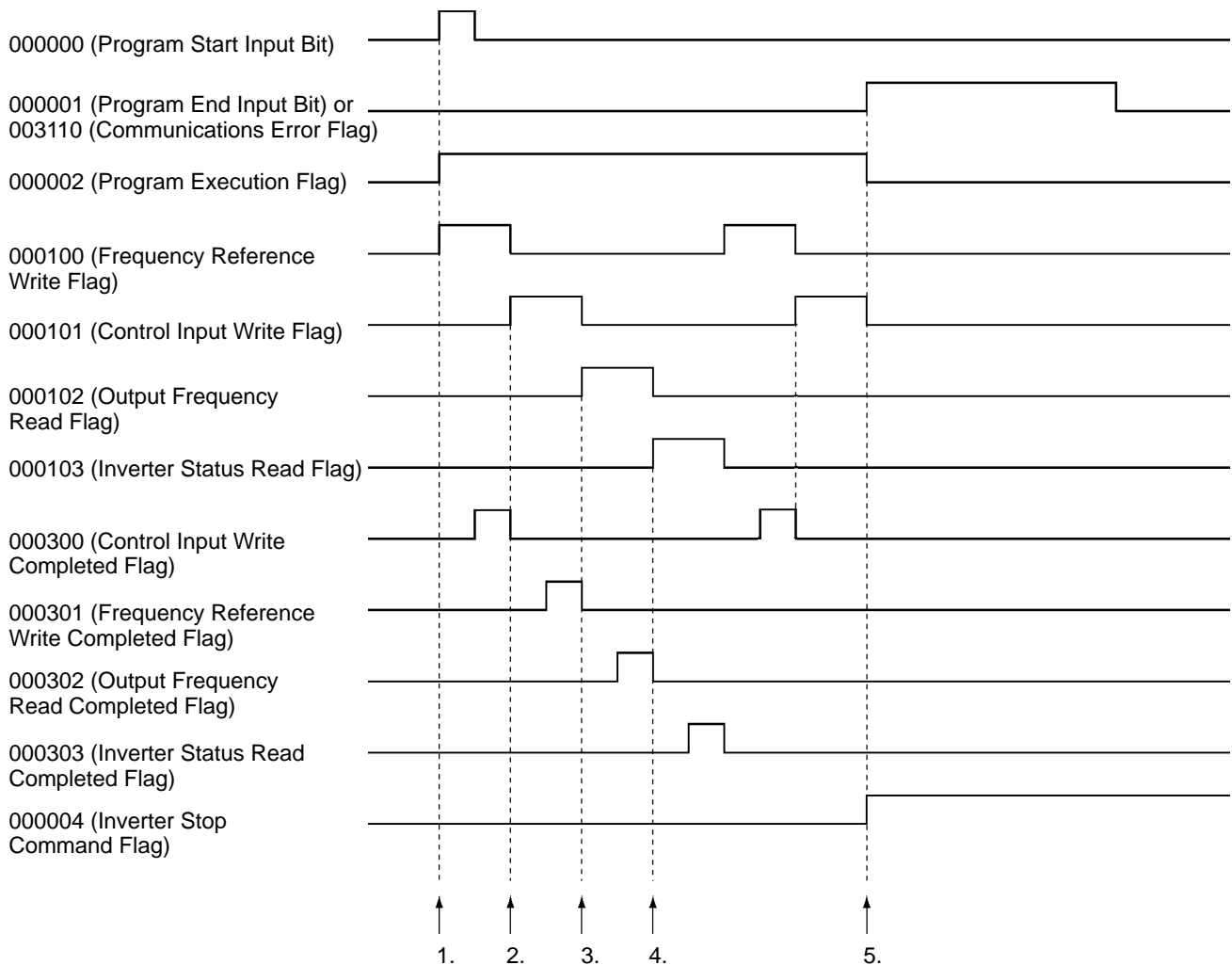

■ **Operation**

1. When the Program Start Input Bit is turned ON, the Program Execution Input Bit will be set to self-holding and the Frequency Reference Write Flag will be turned ON. When the Frequency Reference Write Flag is ON, the frequency reference data in D01000 will be transferred to the Inverter. When the Frequency Reference Write Completed Flag is turned ON, the Frequency Reference Write Flag will be turned OFF and the Control Input Write Flag will be turned ON. (Bits are shifted to achieve this.)
2. When the Control Input Write Flag is turned ON, the Inverter control input specified in word 0010 will be transferred to the Inverter. When the Control Input Write Completed Flag is turned ON, the Control Input Write Flag will be turned OFF and the Output Frequency Reference Read Flag will be turned ON. (Bits are shifted to achieve this.)
3. When the Output Frequency Read Flag is turned ON, the output frequency of the Inverter will be read. When the Output Frequency Read Completed Flag is turned ON, the read output frequency will be stored in D02000, the Output Frequency Read Flag will be turned OFF, and the Inverter Status Read Flag will be turned ON. (Bits are shifted to achieve this.)
4. When the Inverter Status Read Flag is turned ON, the Inverter status will be read. When the Inverter Status Read Completed Flag is turned ON, the read Inverter status will be transferred to word 0020, the Inverter Status Read Flag will be turned OFF, and the Frequency Reference Write Flag will be turned ON. Setting the Frequency Reference Write Flag to ON will repeat the above steps 1 to 4.
5. When the Program End Input Bit is turned ON, the Inverter stop command will be written in the Inverter. (When word m bit 7 turns ON, communications errors will be detected and the Communications Error Flag will be turned ON and will be self-holding. While this flag remains ON, the system will perform the same processing as when the Program End Input Bit is turned ON. When the Communications Error Reset Input Bit is turned ON, the self-holding state will be cleared.)

■ Ladder Program

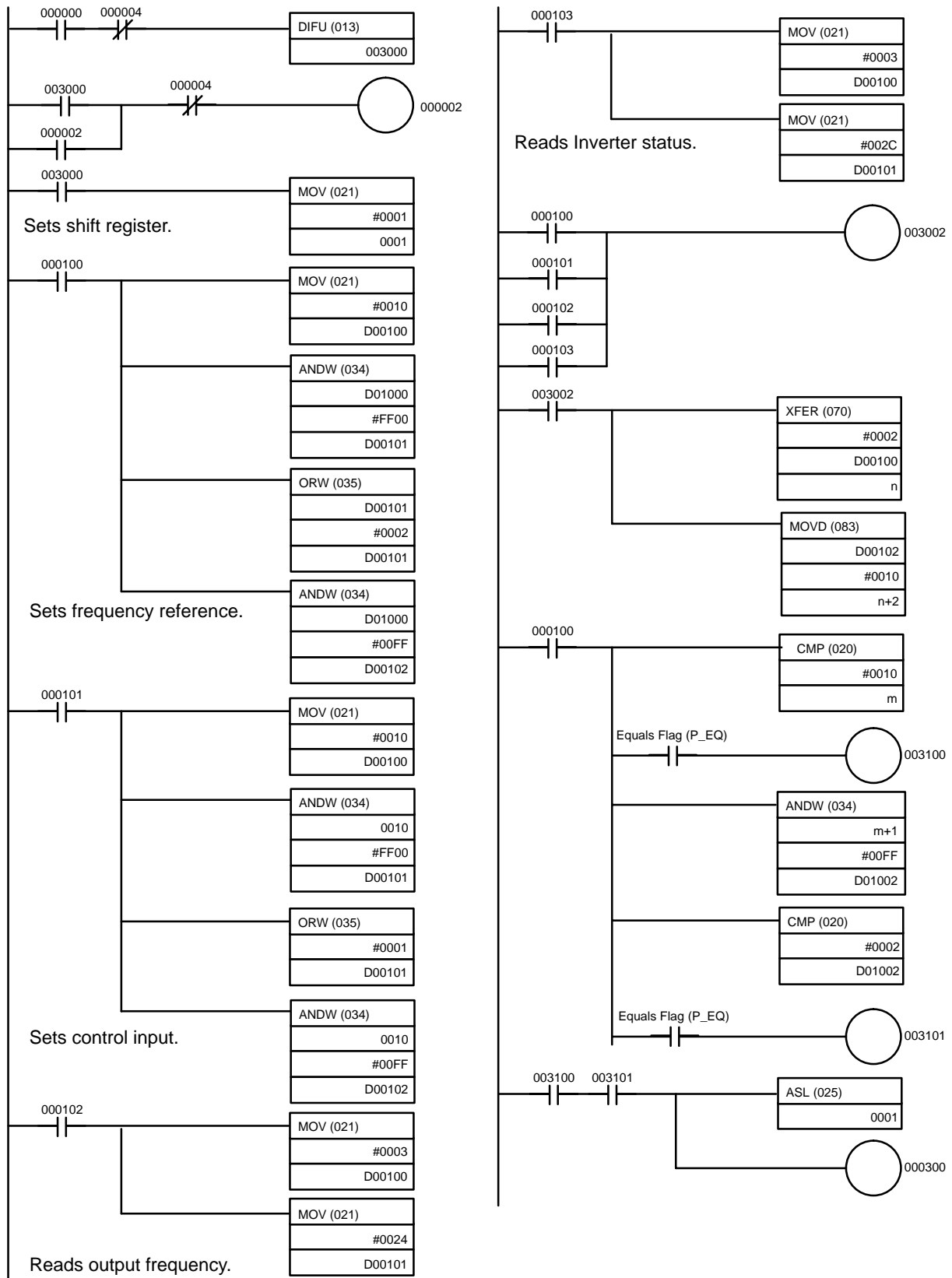

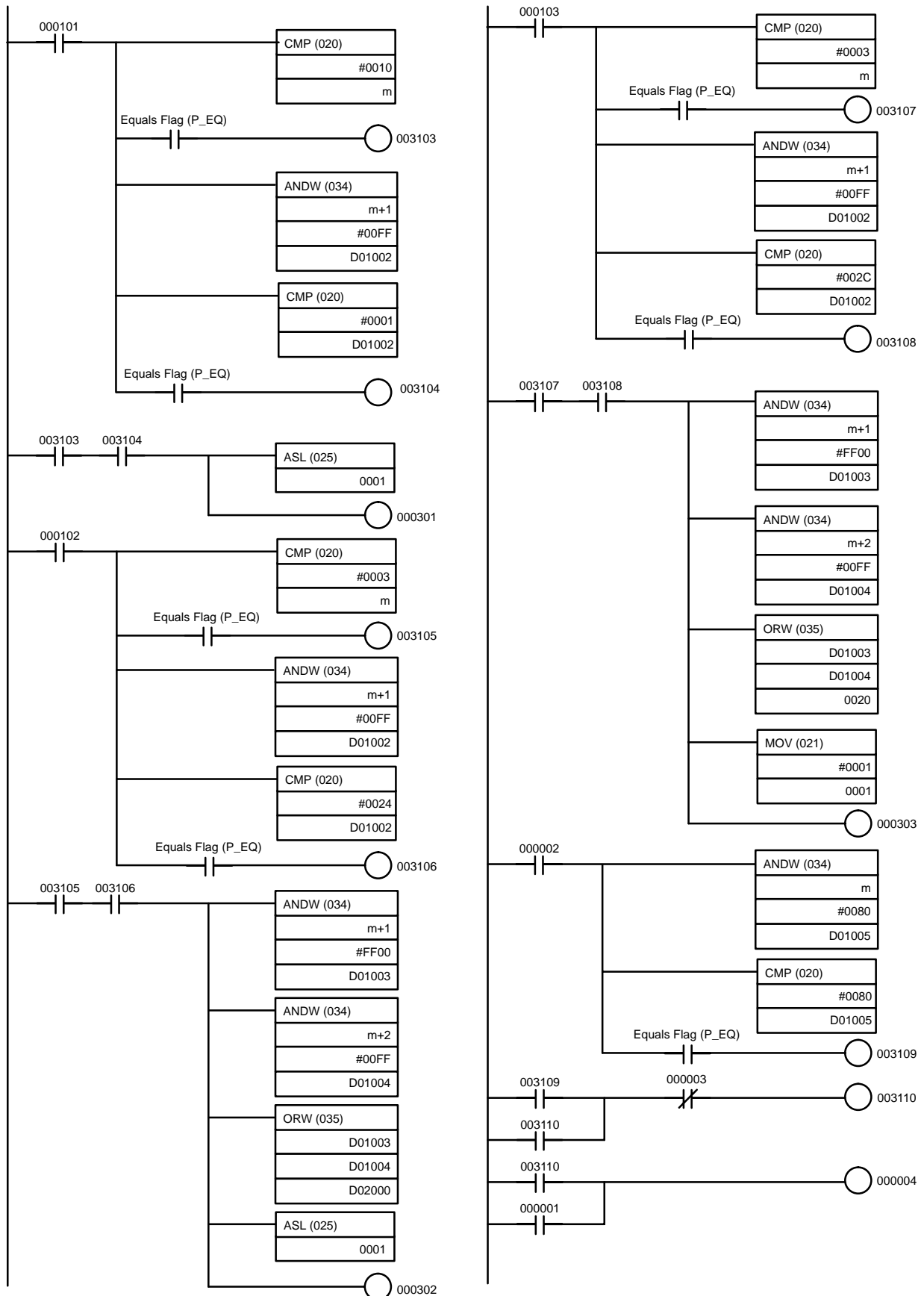

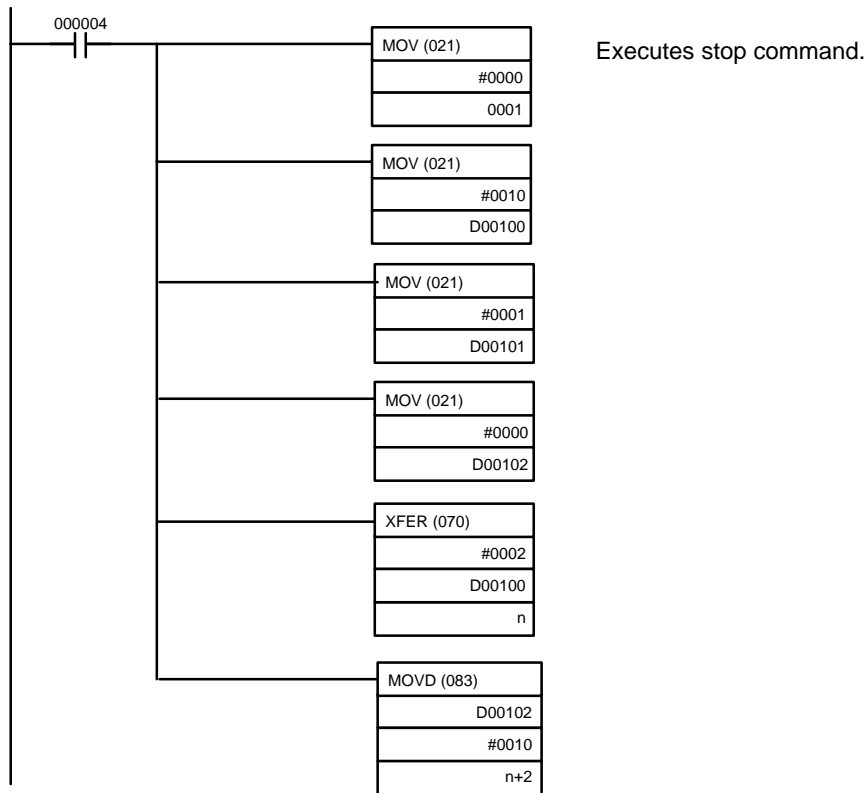

7-3-2 Reading Parameter Data

This programming example is designed to read the parameter data specified in the 3G3MV Inverter. To use special remote I/O, it is necessary to switch the remote I/O operation. Refer to 5-2 *Switching Remote I/O Operation* and change to the special remote I/O operation.

Allocation

Bit	000000	← Read Parameter Input Bit
Bit	000002	← Faulty Data Reset Input Bit
Bit	003000	← Data Read Flag
Bit	003001	← Faulty Data Flag
Bit	003005	← Data Read Completed Flag
	D00000	← Register number of the parameter to be read
	D00001	← Read data

● Remote I/O Allocation Areas

I/O classification	Word	15 to 8	7 to 0
Output (PC to 3G3MV Inverter)	n	Register number (leftmost byte)	Function code (10: Write, 03: Read)
	n+1	Register data (leftmost byte)	Register number (rightmost byte)
	n+2	Not used.	Register data (rightmost byte)
Input (3G3MV Inverter to PC)	m	Register number (leftmost byte)	Function code (10: Write, 03: Read)
	m+1	Register data (leftmost byte)	Register number (rightmost byte)
	m+2	Not used.	Register data (rightmost byte)

■ Timing Chart

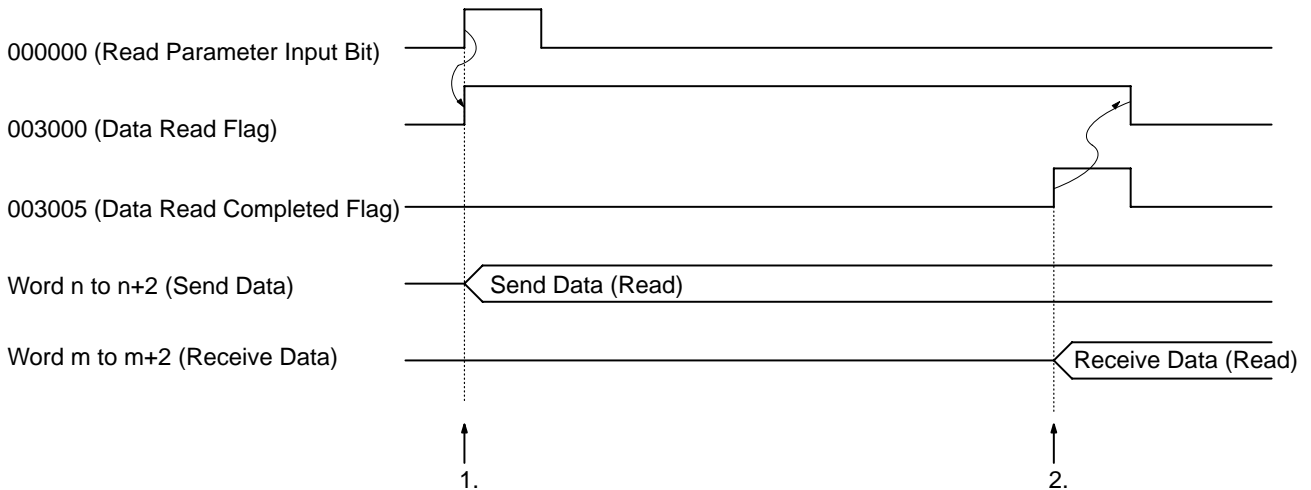

■ Operation

1. Set the register number of the parameter to be read in D00000. When the Read Parameter Input Bit is turned ON, the Data Read Flag will be turned ON and parameter reading processing will be executed.
2. If the data is normally read, the read parameter register number and data will be returned by the Inverter. When the register number that was sent agrees with the received register number, the parameter data will be stored in D00001, the Data Read Completed Flag will be turned ON and the Data Read Flag will be turned OFF.

Note If the send data is faulty, word m bit 7 will be turned ON, which will turn ON the Faulty Data Flag and the program will be stopped until the Faulty Data Reset Input Bit (000002) is turned ON.

■ Ladder Program

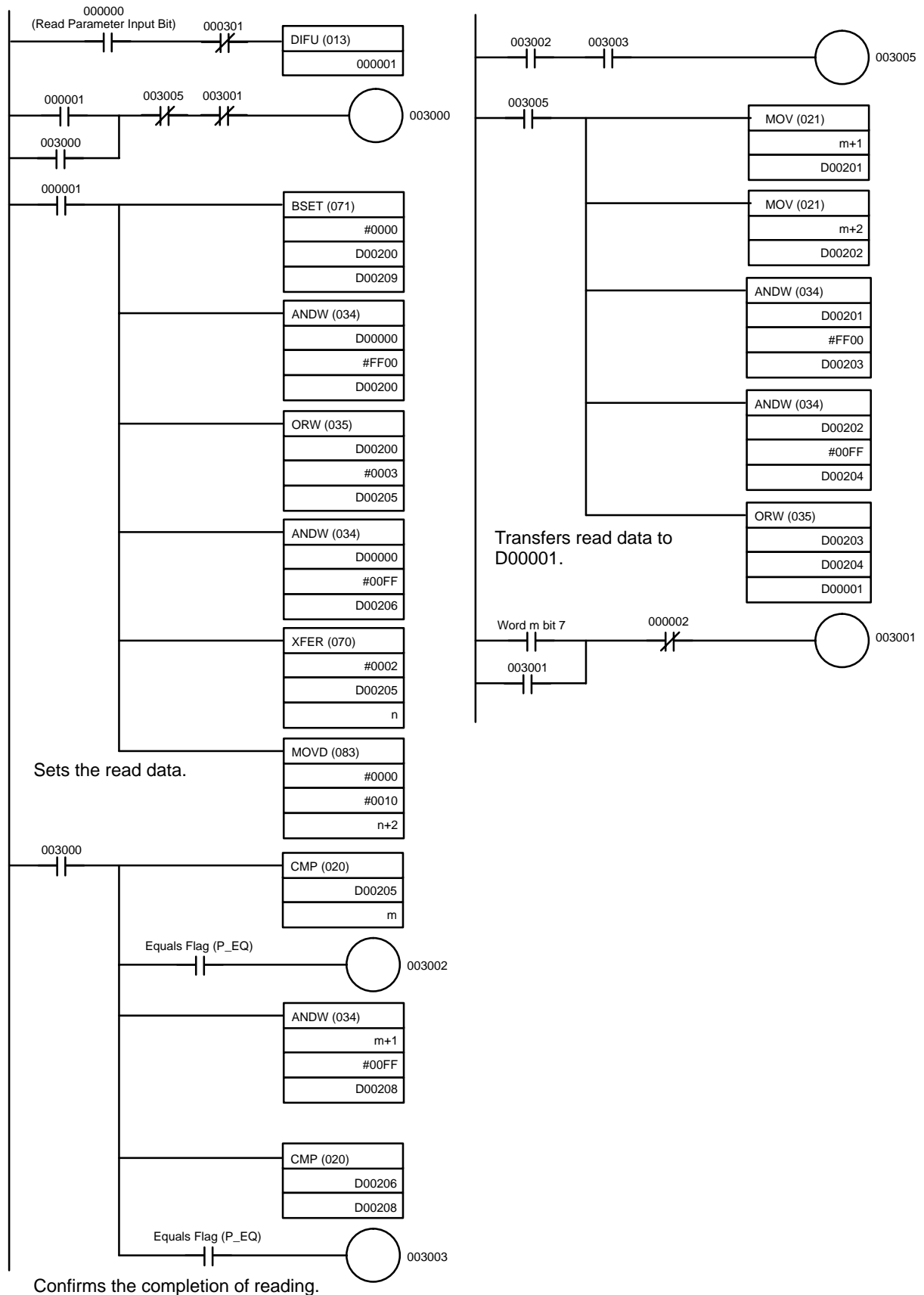

7-3-3 Writing Parameter Data

This programming example is designed to write the parameter data in the 3G3MV Inverter. After writing has been completed, be sure to send an enter command to enable the written data as the Inverter operation data.

To use special remote I/O, it will be necessary to switch the remote I/O operation. Refer to 5-2 *Switching Remote I/O Operation* and change to the special remote I/O operation.

■ Allocations

Bit	000000	← Write Parameter Input Bit
Bit	000002	← Faulty Data Reset Input Bit
Bit	003000	← Data Write Flag
Bit	003005	← Data Agree Flag (Function Code and Register No.)
Bit	000100	← Sending Written Data Flag
Bit	000101	← Sending Enter Command Flag
Bit	000102	← Setting "00" Function Code Flag
Bit	000103	← Data Write Completed Flag
Bit	003010	← Faulty Data Flag

D00000	← Register number of the parameter to be written
D00001	← Written data

● Remote I/O Allocation Areas

I/O classification	Word	15 to 8	7 to 0
Output (PC to 3G3MV Inverter)	n	Register number (leftmost byte)	Function code (10: Write, 03: Read)
	n+1	Register data (leftmost byte)	Register number (rightmost byte)
	n+2	Not used	Register data (rightmost byte)
Input (3G3MV Inverter to PC)	m	Register number (leftmost byte)	Function code (10: Write, 03: Read)
	m+1	Register data (leftmost byte)	Register number (rightmost byte)
	m+2	Not used	Register data (rightmost byte)

■ Timing Chart

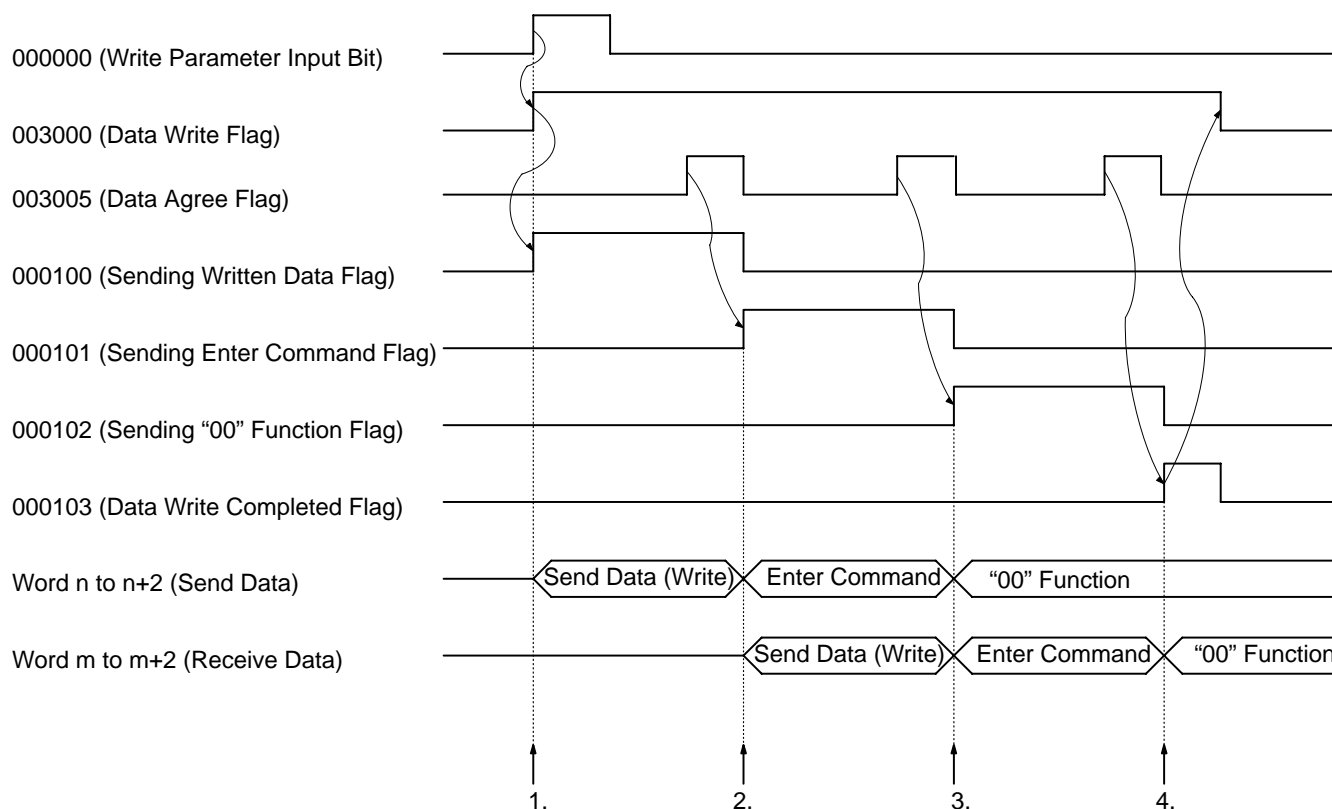

■ Operation

1. Set the register number of the parameter and the data to be written in D00000 and D00001 respectively. When the Write Parameter Input Bit is turned ON, the Data Write Flag will be turned ON and parameter writing processing will be executed.
2. If the data is properly written, the written parameter register number and the function code will be returned from the Inverter. When the sent register number and the function code agree with the received data contents, the Data Agree Flag will be turned ON to send the enter command.
3. If the enter command is normally received, the register number and function code that agree with the enter command will be returned from the Inverter. When the sent register number and function code agree with the received contents, the Data Agree Flag will be turned ON to send the function code "00" (both the register number and function code are 0000).
4. In the same manner, if the function code "00" is normally received, the Data Agree Flag will be turned ON and the Data Write Completed Flag will be turned ON. When the Data Write Completed Flag turns ON, the Data Write Flag will turn OFF and the program will stop.

Note 1. If the enter command remains set, data will be repeatedly written to EEPROM. Therefore, set the function code to "00" (both the register number and function code are 0000), which performs no processing, to disable the enter command.

Note 2. If the sent data is faulty, word m bit 7 will be turned ON, which will turn ON the Faulty Data Flag and the program will be stopped until the Faulty Data Reset Input Bit (000002) is turned ON.

■ Ladder Program

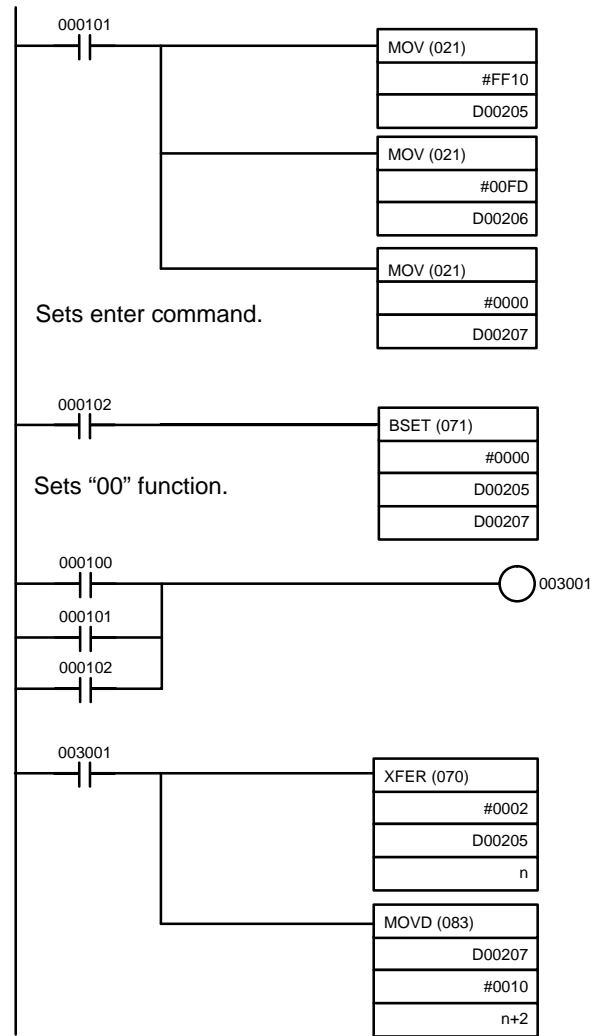
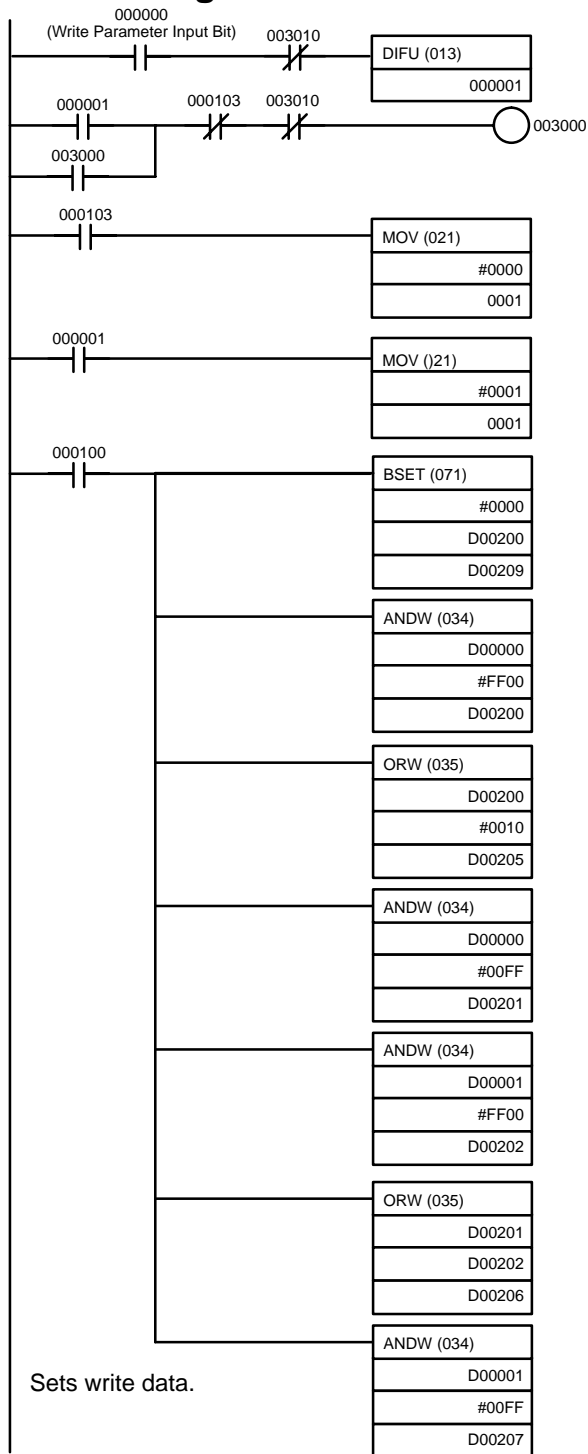

(Continued on the next page.)

(From previous page.)

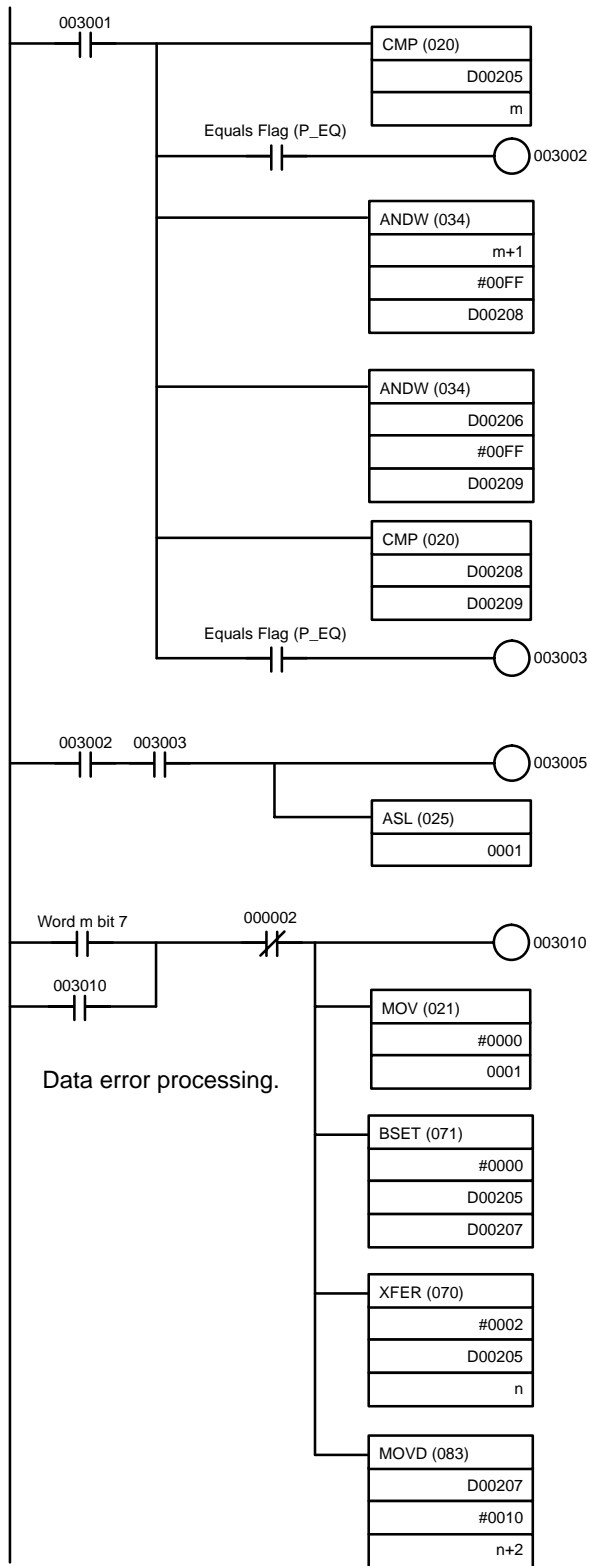

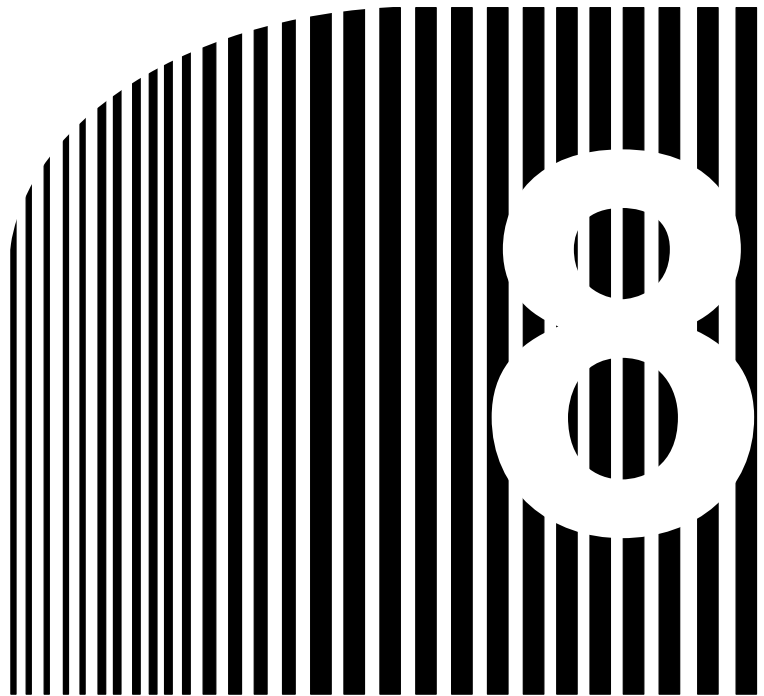

Chapter 8

• Appendices •

- 8-1 Specifications
- 8-2 Objects
- 8-3 DeviceNet Communications Response Time

8-1 Specifications

Item	Specifications
Model	3G3MV-PDRT1-SINV1
Remote I/O	<ul style="list-style-type: none"> • Basic remote I/O: Allocated 2 input and 2 output words. • Standard remote I/O (default setting): Allocated 2 input and 2 output words. • Special remote I/O: Allocated 3 input and 3 output words. • Control remote I/O: Allocated 4 input and 4 output words. <p>Note 1. The user can select from among these four types of remote I/O.</p> <p>Note 2. Basic and standard remote I/O are compatible with DeviceNet. Special remote I/O and control remote I/O are applicable only to this product and is not compatible with DeviceNet.</p>
Explicit messages	<p>A maximum of 32 bytes of data can be sent or received.</p> <p>Note Explicit messages are applicable to the AC/DC drive profile.</p>
Communications power supply specifications	11 to 25 V DC (20 mA max.)
Internal circuit power supply	Provided from 3G3MV Inverter.
Operating location	Indoors (with no corrosive gases, oil mist, metallic particles, etc.)
Operating ambient temperature	-10 to 45°C
Operating ambient humidity	90% RH max. (with no condensation)
Storage temperature	-20 to 60°C
Area	1,000 m max.
Weight	200 g max.

■ Dimensions

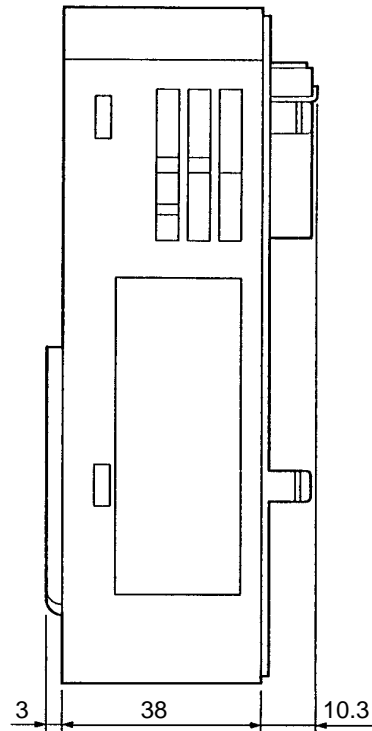
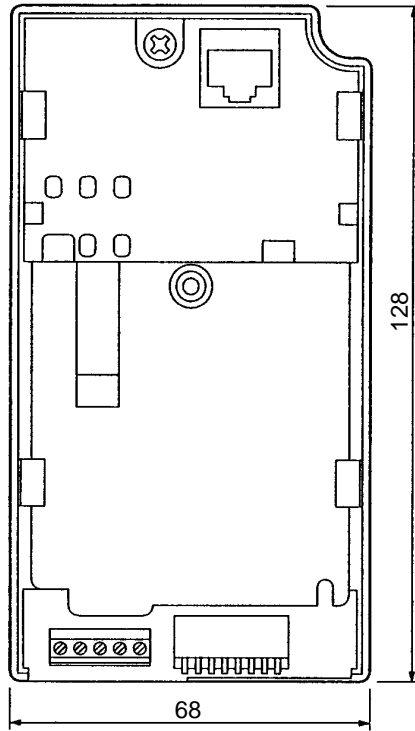

8-2 Objects

There are eight types of object:

- Identify objects (identification information): Class 01 hex
- Message router objects: Class 02 hex
- DeviceNet objects: Class 03 hex
- Assembly objects: Class 04 hex
- DeviceNet connection objects: Class 05 hex
- Motor data objects: Class 28
- Control supervisor objects: Class 29 hex
- AC/DC drive objects: Class 2A hex

For details on motor data objects, control supervisor objects, and AC/DC drive objects, refer to 5-5-6 *Motor Data Objects: Class 28 Hex* through 5-5-8 *AC/DC Drive Objects: Class 2A Hex*.

8-2-1 Identify Objects (Identification Information): Class 01 Hex

Identify objects are objects that provide DeviceNet product information. All of this information is read-only.

■ Support Service Codes

Service code number (Hex)	Service
0E	Get attribute single
05	Reset (return to initial status)

■ Object Details

Instance	Attribute	Name	Content	Setting range	Default (Hex)	Read	Write	Size
00	01	Object Software Revision	Indicates class 01 software revisions. The revision value is advanced whenever there is a change.	---	0001	Yes	No	Word
01	01	Vender ID	Indicates the maker's code. OMRON: 47 (2F hex)	---	002F	Yes	No	Word
	02	Device Type	Indicates the DeviceNet profile classification. The Inverter corresponds to the AC/DC Drive. <ul style="list-style-type: none">• Master Unit: 0• AC/DC Drive: 2	---	0002	Yes	No	Word
	03	Product Code	Assigned to each series by each maker. DeviceNet Communications Unit: 53 (35 hex)	---	0035	Yes	No	Word
	04	Revision	Indicates overall software revisions for the DeviceNet Communications Unit.	---	02.01	Yes	No	Byte × 2
	05	Status	Indicates the communications status of the DeviceNet Communications Unit. (See details below.)	---	0000	Yes	No	Word
	06	Serial Number	Indicates the product serial number of the DeviceNet Communications Unit. (60000000 hex onwards)	---	Depends on product.	Yes	No	Long
	07	Product Number	Indicates product model number. 3G3MV-PDRT1-SIN	---	Number shown at left.	Yes	No	String
	08	State	Indicates Inverter status. <ul style="list-style-type: none">• 3 hex: Inverter ready	---	03	Yes	No	Byte

● Status Details

Bit	Item	Content
0	Connection	0: Not connected. 1: Master/Slave connected.
1	Not used.	---
2	Configuration	0: Data never changed. 1: Data other than default.
3 to 15	Not used.	---

Note Bits that are not used are all zeros.

8-2-2 Message Router Objects: Class 02 Hex

Message router objects have the function of distributing DeviceNet communications data. Message and remote I/O operations, and so on, must pass through these objects to be distributed. Message router objects themselves are involved in internal processing only and do not have data to be exchanged externally.

■ Support Service Code

Service code number (Hex)	Service
0E	Get attribute single

■ Object Details

Instance	Attribute	Name	Content	Setting range	Default (Hex)	Read	Write	Size
00	01	Object Software Revision	Indicates class 02 software revisions. The revision value is advanced whenever there is a change.	---	0001	Yes	No	Word

8-2-3 DeviceNet Objects: Class 03 Hex

DeviceNet objects are objects related to DeviceNet communications information and operations.

■ Support Service Code

Service code number (Hex)	Service
0E	Get attribute single
10	Set attribute single

■ Object Details

Instance	Attribute	Name	Content	Setting range	Default (Hex)	Read	Write	Size
00	01	Object Software Revision	Indicates class 03 software revisions. The revision value is advanced whenever there is a change.	---	0001	Yes	No	Word
01	01	MAC ID	Indicates the set value of the communications node address. It is read-only because the setting is made by the external setting switch.	---	00	Yes	No	Byte
	02	Baud Rate	Indicates the baud rate. It is write-protected because the setting is made by the external setting switch. 00: 125 Kbps 01: 250 Kbps 02: 500 Kbps	---	00	Yes	No	Byte
	05	Allocation Information	Indicates DeviceNet communications connection information. Used to check whether connection is already made. • See details below. • Cannot be written for explicit messages. (Error is returned.)	---	0000	Yes	No	Byte × 2

● Allocation Information Details

Byte	Bit 7	Bit 6	Bit 5	Bit 4	Bit 3	Bit 2	Bit 1	Bit 0
0	0	0	0	0	0	0	1: Remote I/O connection status	1: Explicit message connection status
1	0	0	Node address (MAC ID) of Master connected for DeviceNet communications.					

Note The Master Unit automatically writes allocation information when the communications connection is completed. After the Master Unit has written the information, writing is prohibited.

8-2-4 Assembly Objects: Class 04 Hex

Assembly objects are objects related to remote I/O operations. Remote I/O operations are configured with these objects for communications.

■ Support Service Codes

Service code number (Hex)	Service
0E	Get attribute single
10	Set attribute single

■ Object Details

Instance	Attribute	Name	Content	Setting range	Default (Hex)	Read	Write	Size
00	01	Object Software Revision	Indicates class 04 software revisions. The revision value is advanced whenever there is a change.	---	0001	Yes	No	Word
14	03	Remote I/O data	Operation is the same as for basic remote I/O (output).	See note 1.	00. 00. 00. 00	Yes	Yes	Byte × 4
15	03	Remote I/O data	Operation is the same as for standard remote I/O (output).	See note 1.	00. 00. 00. 00	Yes	Yes	Byte × 4
46	03	Remote I/O data	Operation is the same as for basic remote I/O (input).	---	00. 00. 00. 00	Yes	No	Byte × 4
47	03	Remote I/O data	Operation is the same as for standard remote I/O (input).	---	00. 00. 00. 00	Yes	No	Byte × 4
64	03	Remote I/O data	Operation is the same as for special remote I/O (output).	See note 1.	00. 00. 00. 00. 00	Yes	Yes	Byte × 5
65	03	Remote I/O data	Operation is the same as for control remote I/O (output).	See note 1.	00. 00. 00. 00. 00. 00. 00. 00.	Yes	Yes	Byte × 8
96	03	Remote I/O data	Operation is the same as for special remote I/O (input).	---	00. 00. 00. 00. 00	Yes	No	Byte × 5
97	03	Remote I/O data	Operation is the same as for control remote I/O (input).	---	00. 00. 00. 00. 00. 00. 00. 00.	Yes	No	Byte × 8

Note 1. The setting ranges are the same as the respective remote I/O setting ranges.

- Note 2.** The remote I/O operations are the same as those explained in *5-1 Remote I/O* and *5-2 Special Remote I/O Operation*.
- Note 3.** Remote I/O can be performed by means of message communications. When a normal remote I/O communications connection is established, however, the message communications cannot be used for that purpose. Even if an attempt is made to use message communications, they will be overwritten by remote I/O inputs.

8-2-5 DeviceNet Connection Objects: Class 05 Hex

DeviceNet connection objects are objects related to information and operations involving DeviceNet communications connections. The Master Unit uses the information and operations of these objects to execute the initial processing for communications.

■ Support Service Codes

Service code number (Hex)	Service
0E	Get attribute single
10	Set attribute single

■ Object Details

Instance	Attribute	Name	Content	Setting range	Default (Hex)	Read	Write	Size
00	01	Object Software Revision	Indicates class 05 software revisions. The revision value is advanced whenever there is a change.	---	0001	Yes	No	Word
01 Explicit message	01	State	Indicates the status of this object (instance). 00: Does not exist in network, or is not ready. 01: In network state, waiting for connection event from Master Unit. 02: Waiting for connection ID (attribute) writing. 03: Connection completed. 04: Timeout	---	Must be "03" when communications are established.	Yes	No	Byte
	02	Instance type	Indicates the type of object (instance). 00: Explicit message 01: Remote I/O	---	00	Yes	No	Byte
	03	Transport class trigger	Indicates the communications configuration for the DeviceNet Communications Unit.	---	83	Yes	No	Byte
	04	Produced connection ID	Indicates the label used for the communications header for the DeviceNet Communications Unit. Note: These are set when the communications connection is made.	---	---	Yes	No	Word
	05	Consumed connection ID		---	---	Yes	No	Word
	06	Initial comm characteristics	Indicates the communications configuration for the DeviceNet Communications Unit.	---	21	Yes	No	Byte
	07	Produced connection size	Indicates the maximum number of bytes for transmission.	---	0020	Yes	No	Word
	08	Consumed connection size	Indicates the maximum number of bytes for reception.	---	0020	Yes	No	Word

Instance	Attribute	Name	Content	Setting range	Default (Hex)	Read	Write	Size
01 Explicit message	09	Expected packet rate	Indicates the length of the internal processing timeout when a communications request is received. Incremented by 10-ms units.	0 to 65,535 (ms)	09C4 (2,500 ms)	Yes	Yes	Word
	0C	Watchdog time-out action	Indicates the action for internal processing timeout related to communications. 00: Retain timeout status (until reset or cleared). 01: Cut connection automatically. 02: Operate again with same connection as is.	---	01	Yes	No	Byte
	0D	Produced connection path length	Indicates number of bytes of data for produced connection path. (No data for explicit messages.)	---	0000	Yes	No	Word
	0E	Produced connection path	Indicates the data for defining the application object for sending this object (instance). (No data for explicit messages.)	---	---	Yes	No	Array
	0F	Consumed connection path length	Indicates the number of bytes of data for the consumed connection path. (No data for explicit messages.)	---	0000	Yes	No	Word
	10	Consumed connection path	Indicates the data for defining the application object for receiving this object (instance). (No data for explicit messages.)	---	---	Yes	No	Array

Instance	Attribute	Name	Content	Setting range	Default (Hex)	Read	Write	Size
02 Remote I/O	01	State	Indicates the status of this object (instance). 00: Does not exist in network, or is not ready. 01: In network state, waiting for connection event from Master Unit. 02: Waiting for connection ID (attribute) writing. 03: Connection completed. 04: Timeout	---	Must be "03" when communications are established.	Yes	No	Byte
	02	Instance type	Indicates the type of object (instance). 00: Explicit message 01: Remote I/O	---	01	Yes	No	Byte
	03	Transport class trigger	Indicates the communications configuration for the DeviceNet Communications Unit.	---	82	Yes	No	Byte
	04	Produced connection ID	Indicates the label used for the communications header for the DeviceNet Communications Unit.	---	---	Yes	No	Word
	05	Consumed connection ID	Note: These are set when the communications connection is made.	---	---	Yes	No	Word
	06	Initial comm characteristics	Indicates the communications configuration for the DeviceNet Communications Unit.	---	01	Yes	No	Byte

Instance	Attribute	Name	Content	Setting range	Default (Hex)	Read	Write	Size
02 Remote I/O	07	Produced connection size	Indicates the maximum number of bytes for transmission.	---	0004	Yes	No	Word
	08	Consumed connection size	Indicates the maximum number of bytes for reception.	---	0004	Yes	No	Word
	09	Expected packet rate	Indicates the length of the internal processing timeout when a communications request is received.	0 to 65,535 (ms)	0000 (0 ms)	Yes	Yes	Word
	0C	Watchdog time-out action	Indicates the action for internal processing timeout related to communications. 00: Retain timeout status (until reset or cleared). 01: Cut connection automatically. 02: Operate again with same connection as is.	---	01	Yes	No	Byte
	0D	Produced connection path length	Indicates number of bytes of data for produced connection path.	---	0003	Yes	No	Word
	0E	Produced connection path	Indicates the data for defining the application object for sending this object (instance). Note: Has a function for switching the DeviceNet Communication Unit's remote I/O operation.	---	62 34 37	Yes	No	Array
	0F	Consumed connection path length	Indicates the number of bytes of data for the consumed connection path.	---	0003	Yes	No	Word
	10	Consumed connection path	Indicates the data for defining the application object for receiving this object (instance). Note: Has a function for switching the DeviceNet Communication Unit's remote I/O operation.	---	62 31 35	Yes	No	Array

Note "Reception" means output (3G3MV to SYSMAC PC), and "transmission" means input (SYSMAC PC to 3G3MV).

8-3 DeviceNet Communications Response Time

This section describes communications response time when OMRON Master and Slave Units are being used. Use this section for reference when planning I/O timing. The equations provided here are valid under the following conditions:

- The Master Unit is operating with the scan list enabled.
- All of the required Slaves are participating in communications.
- No errors are being indicated at the Master Unit
- Messages are not being produced in the network (from another company's configurator, for example).

■ Communications Cycle Time

● One Master in Network

The following equations show the communications cycle time (T_{RM}) when there is only one Master in the network. If the calculation result is less than 2 ms, the communications cycle time (T_{RM}) will be considered as 2 ms.

$$T_{RM} = \Sigma \text{ Communications time for 1 Slave} \\ + \text{ High-density Unit processing time} \\ + \text{ Explicit message processing time} \\ + \text{ COS/Cyclic connection communications time} \\ + 0.01 \times N + 1.0$$

Note N = Number of Slaves.

Communications Time for 1 Slave

This is the time required for 1 Slave to perform communications. "Σ Communications time for 1 Slave" in the above equation represents the sum of the communications times for each Slave in the network. The equations used to calculate the communications time (T_{RS}) for different types of Slave are given below.

Output Slaves with 8 or Less Bytes of Output

$$T_{RT} = 0.016 \times T_B \times S_{OUT1} + 0.11 \times T_B + 0.07$$

S_{OUT1} : The number of Output Slave output words
 T_B : The baud rate factor
 (500 kbps: $T_B = 2$; 250 kbps: $T_B = 4$; 125 kbps: $T_B = 8$)

Input Slaves with 8 or Less Bytes of Input

$$T_{RT} = 0.016 \times T_B \times S_{IN1} + 0.06 \times T_B + 0.05$$

S_{IN1} : The number of Input Slave input words
 T_B : The baud rate factor
 (500 kbps: $T_B = 2$; 250 kbps: $T_B = 4$; 125 kbps: $T_B = 8$)

Mixed I/O Slaves with 8 or Less Bytes of Both Input and Output

$$T_{RT} = 0.016 \times T_B \times (S_{OUT2} + S_{IN2}) + 0.11 \times T_B + 0.07$$

S_{OUT2} : The number of Mixed I/O Slave output words
 S_{IN2} : The number of Mixed I/O Slave input words
 T_B : The baud rate factor
 (500 kbps: $T_B = 2$; 250 kbps: $T_B = 4$; 125 kbps: $T_B = 8$)

Slaves with More than 8 Bytes of Input or Output (or Both)

$$T_{RT} = T_{OH} \times T_{BYTE-IN} \times B_{IN} \times T_{BYTE-OUT} \times B_{OUT}$$

- T_{OH} : Protocol overhead
- $T_{BYTE-IN}$: Input byte transmission time
- B_{IN} : Number of input bytes
- $T_{BYTE-OUT}$: Output byte transmission time
- B_{OUT} : Number of output bytes

Baud rate	T_{OH}	$T_{BYTE-IN}$	$T_{BYTE-OUT}$
500 kbps	0.306 ms	0.040 ms	0.036 ms
250 kbps	0.542 ms	0.073 ms	0.069 ms
125 kbps	1.014 ms	0.139 ms	0.135 ms

Note Calculate with $B_{OUT} = 0$ for Slaves with inputs only and $B_{IN} = 0$ for Slaves with outputs only.

High-density Unit Processing Time

Add 3.5 ms if there is at least 1 Slave with more than 8 bytes of input or output (or both).

Explicit Message Processing Time

Add the following explicit message processing time when performing explicit message communications (sending or receiving).

$$\text{Explicit message processing time} = 0.11 \times T_B \times n$$

- n : The number of explicit messages that are sent or received within 1 cycle of the CPU Unit
- T_B : The baud rate factor
(500 kbps: $T_B = 2$; 250 kbps: $T_B = 4$; 125 kbps: $T_B = 8$)

COS/Cyclic Connection Communications Time

Add the following COS/cyclic connection communications time.

$$\text{COS/cyclic connection communications time} = (0.05 + 0.008 \times S) \times T_B \times n$$

- S : The total number of input and output bytes for COS/cycle connections
- T_B : The baud rate factor
(500 kbps: $T_B = 2$; 250 kbps: $T_B = 4$; 125 kbps: $T_B = 8$)
- n : The number of nodes for which COS/cyclic connections occur within 1 cycle of the CPU Unit

• More than One Master in Network

Calculate the communications cycle time according to the above equation for the Slaves of each Master Unit. The communications cycle time for the entire network is the sum of communications cycle times for each Master Unit.

I/O Response Time of Inverter

The following shows processing time between the Inverter and the DeviceNet Communications Unit.

- DP-RAM processing time between the Inverter and DeviceNet Communications Unit: 8 ms
- Inverter input scanning: 8 ms (read twice)
- Inverter output scanning: 8 ms
- Inverter parameters scanning: 20 ms

Inverter I/O response time

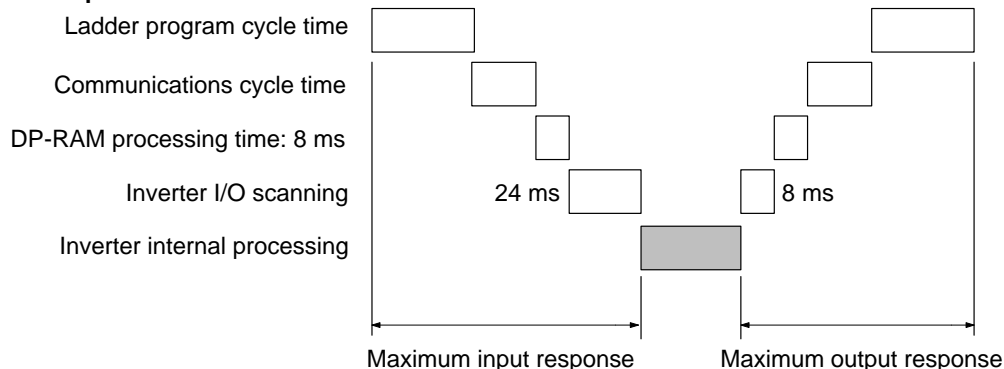

Note 1. The internal processing time varies depending on the controls to be executed.

Note 2. Input scanning for parameter reading or writing requires 20 ms.

Index

A

AC/DC drive objects, 5-33, 5-37
 details, 5-37
Alarm Bit, 7-14
allocation areas, 1-14
 fixed allocation, 4-7
 free allocation, 4-13
assembly objects, 5-33
 details, 8-7
 service codes, 8-7
At Frequency Bit, 7-2

B–C

Baseblock Bit, 7-14
basic remote I/O
 inputs, 5-6
 outputs, 5-6
baud rate, 1-11
 restrictions, 2-4
 settings, 3-3
communications
 cable shielding, 2-16
 distance, 2-4
 explicit messages, 1-3
 fault processing, 7-5–7-12
 functions, 1-3
 line noise, 2-15
 power supply, 1-11, 2-2, 2-6
 noise prevention, 2-16
 suspension, 2-17
 specifications, 1-11
 with Configurator, 1-14
 with SYSMAC PCs, 1-3, 1-14
 without Configurator, 1-14
communications data
 reference examples, 5-40
 setting examples, 5-39
Communications Error Flag, 7-14
Communications Error Reset Input Bit, 7-14
Communications Fault Reset Input Bit, 7-13
communications flags, 5-24, 5-31
communications line errors, operation indicators, 6-2
Communications Timeover CE Bit, 7-14
Configurator, 1-6, 1-7
 3G8E2-DRM21, 1-10
 3G8F5-DRM21, 1-10
 communications, 1-14
 overview, 1-10

 specifications, 1-10
 connection objects, 5-10
 connections, methods, 2-2
 Control From Net Bit, 7-2
 Control Input Write Completed Flag, 7-14
 Control Input Write Flag, 7-14
 control monitor objects, details, 5-35
 control supervisor objects, 5-33, 5-34
CRC check, 1-11
crimp terminals, 3-9
current capacity, 2-9

D

daisy-chain drop lines, 1-7
DeviceNet connection objects, 5-33
 details, 8-9
 service codes, 8-9
DeviceNet objects, 5-33
 allocations, 8-7
 details, 8-6
 service codes, 8-6
drop lines, 2-2, 2-3
 branching patterns, 2-3
 daisy-chain, 1-7
 maximum length, 1-11, 2-4
During Fault Retry Bit, 7-14
During Forward Run Input Bit, 7-2
During Reverse Run Input Bit, 7-2
During Run Bit, 7-14

E

EEPROM, 6-7
Equals Flag
 C200HX/HG/HE, 5-29
 CS1 Series, 5-29
Error Flag
 C200HX/HG/HE, 5-29
 CS1 Series, 5-29
errors
 communications line, 6-2
 explicit messages, 6-5
 setup
 I/O Area Overlap, 4-10
 I/O Area Range Violation, 4-10
 special remote I/O, 6-6
 verification, 4-10

Index

explicit messages, 1-3, 1-6
errors, 6-5
overview, 5-21
External Fault Input Bit, 7-13

F–G

fault, Inverter, 6-7
Fault Bit, 7-3, 7-6, 7-14
fault codes, 5-36
Fault Flag, 7-2, 7-6
Fault Read Flag, 7-6
Fault Reset Bit, 7-13
Fault Reset Input Bit, 7-2
FINS commands, 1-6, 7-9
fixed allocation, 1-8, 4-2
allocation areas, 4-7
application procedure, 4-11
communications, 1-14
example, 4-11
Forward Input Bit, 7-2
Forward/Stop Bit, 7-2, 7-13
free allocation, 1-7, 1-9, 1-10
allocation areas, 4-13
application procedure, 4-16
communications, 1-14
example, 4-16
restrictions, 4-5, 4-15
with allocated DM Area words, 4-3
with Configurator, 4-4
Frequency Agree Bit, 7-14
Frequency Detect Bits, 7-14
frequency reference
ladder program, 7-4
selection, 4-20
settings, 4-21, 7-14
Frequency Reference Input Bit, 7-2
Frequency Reference Mode Bit, 7-14
Frequency Reference Write Completed Flag, 7-14
Frequency Reference Write Flag, 7-14
functions, 1-2
grounding, 2-15
Communications Unit, 2-15
network, 2-15

I

I/O Area Overlap, 4-10
I/O Area Range Violation, 4-10

I/O power supply, 2-2
identify objects, 5-33
details, 8-5
service codes, 8-4
status, 8-5
installation
Communications Unit, 3-6
precautions, 3-5
T-branch Tap, 3-10
T-branch Tap Terminating Resistor, 3-12
Terminating Resistor, 3-12
instruction set
CMND, 7-9
CMND(194), 5-21, 5-29
IOWR, 7-9
C200HX/HG/HE, 5-26
CS1 Series, 5-24
Interface Unit, 1-10
internal circuit power supply, 2-2
Inverter, 1-12
allocated words, 5-4
control input, 7-14
word allocation, 7-13
fault detection, 6-7
fault processing, 7-5–7-12
fault status, 6-7
monitoring functions, 5-44
run commands, 4-19, 5-4
settings, 4-19
status, word allocation, 7-14
Inverter Ready Bit, 7-2, 7-14
Inverter Status Read Completed Flag, 7-14
Inverter Status Read Flag, 7-14
Inverter Stop Command Flag, 7-14
ISA Board, 1-10

M

message communications, 1-2, 1-3, 1-6, 1-8
command format, 5-32
explicit messages, 5-21
FINS messages, 5-21
operations, 5-20
overview, 5-20
programming, 7-5
response format, 5-32
response read timing, 5-23, 5-31
responses, 5-32
timing, 5-23, 5-27, 5-28, 5-31
Message Communications Enabled Flag, 5-27, 7-6, 7-10
C200HX/HG/HE, 5-29
CS1 Series, 5-29
Message Communications Status Flag, 5-28
Message Execution Flag, 7-10
message router objects, 5-33

Index

- details, 8-6
- service codes, 8-6
- Message Sent Flag, 7-10
- message transmission, 5-29
- motor constant objects, details, 5-33
- motor data objects, 5-33
- mounting procedure, 3-6
- multi-drop trunk lines, 1-7
- Multi-function Input Bits, 7-13
- multi-layer network, 1-6
- multi-vendor network, 1-3, 1-6, 1-8

N

- Net Control, 5-4
- Net Control Bit, 7-2
- Net Reference, 5-4
- Net Reference Bit, 7-2
- Network Communications Enabled Flag, 5-23, 5-31
- Network Communications Error Flag, 5-24, 5-31
- network configuration, 1-6
 - components, 2-2
 - node location, 2-11
 - overview, 2-2
 - power supply location, 2-9
 - restrictions, 2-4
- node addresses, 3-3
 - setting pins, 3-4
- noise prevention
 - communications power supply, 2-16
 - peripheral devices, 2-18
 - wiring, 2-17
- nomenclature, 3-2

O-P

- objects, types, 8-4
- operation indicators, 3-3, 6-2
- output frequency monitor, 7-14
- Output Frequency Read Completed Flag, 7-14
- Output Frequency Read Flag, 7-14
- Overtorque Detection Bit, 7-14
- parameter constants, 5-13, 5-48
 - function group 1, 5-48
 - function group 2, 5-50
 - function group 3, 5-51

- function group 4, 5-53
- parameter objects, 5-9
- PMCIA Card, 1-10
- power supply
 - calculating location, 2-9
 - dual, 2-14
 - location, 2-7
 - multiple, 2-13
 - noise prevention, 2-16
- Power Supply Tap, 2-6
 - configuration, 2-13
 - internal circuitry, 2-13
- Program End Input, 7-13
- Program End Input Bit, 7-14
- Program Execution Flag, 7-14
- Program Start Input Bit, 7-10, 7-13, 7-14
- Programmable Controller
 - C200HS, 1-14
 - C200HX/HG/HE, 1-14
 - CS1 Series, 1-14
 - CV Series, 1-14
- programming
 - bits, 7-14
 - reading data, 7-9
 - reading parameter data, 7-19
 - writing data, 7-9
 - writing parameter data, 7-22

R

- Reference From Net Bit, 7-2
- remote I/O
 - allocation areas, 7-15, 7-20, 7-22
 - basic, 5-5
 - communications, 1-2, 1-3, 1-6, 1-8
 - free allocation, 1-7, 1-10
 - initial settings, 5-3
 - special, 5-7, 5-12
 - errors, 6-6
 - programming, 7-13
 - standard, 5-3, 5-6
 - programming, 7-2
 - switching operations, 5-9
 - restrictions, 5-10
- Reset Input Bit, 7-6
- Reverse Input Bit, 7-2
- Reverse/Stop Bit, 7-2, 7-13
- rotational speed monitor data, 5-5
- rotational speed reference data, 5-5, 7-2
- Run Command Mode Bit, 7-14

Index

S

- scan lists, 4-5
- Sending Message Flag, 7-6, 7-10
- special 5-wire cables, 1-11
- special remote I/O
 - allocated words, 5-12
 - communications timing, 5-14
 - errors, 6-6
 - function codes, 5-12
 - inputs, 5-7
 - outputs, 5-7
 - overview, 5-12
 - programming, 7-13
 - responses, 5-14
- specifications
 - communications, 1-11
 - Configurator, 1-10
 - DeviceNet, 1-3, 1-6, 1-8
- speed reference, 5-5
- standard remote I/O
 - inputs, 5-7
 - outputs, 5-6
 - programming, 7-2
- startup procedure, 4-22
- system configuration, 1-8
 - example, 1-6
 - fixed allocation, 1-8
 - free allocation, 1-9
 - with Configurator, 1-9
 - without Configurator, 1-8

T-Z

- T-branch multi-drop lines, 1-7
- T-branch Tap, 2-5
 - DCN1-1C, 3-11
 - DCN1-3C, 3-11
 - installation, 3-10
- T-branch Tap Terminating Resistor, 3-12
- Terminal Block, 3-2
 - wiring, 3-9
- Terminal-block Terminating Resistor, 2-2
- Terminating Resistor, 2-2
 - connection, 3-12
 - connections, 2-5
- Thick Cable, 1-11, 2-10
 - maximum length, 2-4
- Thin Cable, 1-11, 2-10
 - maximum length, 2-4
- trunk lines, 2-2, 2-3
 - branching patterns, 2-3
- UV Bit, 7-14
- wiring
 - communications cables, 3-8
 - precautions, 3-5
 - preparations, 3-8
 - Terminal Block, 3-9
- word allocations
 - overview, 4-2
 - SYSDRIVE 3G3MV Inverters, 5-4
- Zero Speed Bit, 7-14

Revision History

A manual revision code appears as a suffix to the catalog number on the front cover of the manual.

Cat. No. I529-E1-02
 Revision code

The following table outlines the changes made to the manual during each revision. Page numbers refer to the previous version.

Revision code	Date	Revised content
01	May 1999	Original production
02	October 2001	<p>The following changes were made throughout the manual: “1” was added to the model number; “CompoBus/D” was removed or changed to “DeviceNet”; “CS1 Series” was changed to “CS Series” or “CS/CJ Series” where appropriate; information related to CS/CJ-series DeviceNet Units and CJ-series PCs was added; and IOWR was changed to CMND where applicable. In addition, the following changes were made.</p> <p>Preliminary Pages: Information was added under “Notice” on the inside front cover and “General Precautions” were added to the precautionary information.</p> <p>Page 1-2: Minor change made to last paragraph.</p> <p>Page 1-3: Information under “Multi-vendor Network” changed.</p> <p>Page 1-4: Section on new functions added.</p> <p>Page 1-10: Changes made to first paragraph and information added to table.</p> <p>Pages 1-11 and 1-12: Information added on maximum number of Inverters.</p> <p>Page 2-3: Paragraph preceding the note removed.</p> <p>Page 2-12: Information added to note.</p> <p>Page 2-17: Precaution added.</p> <p>Page 4-2: Information on word allocations changed in several places.</p> <p>Page 4-3: Information on scan lists changed in several places.</p> <p>Page 4-6: Information on procedures for word allocation added.</p> <p>Page 4-7: Changes made to information on verification error. Minor changes made to allocation example.</p> <p>Page 4-8: Changes made to procedure in several places.</p> <p>Page 4-10: Information on allocation restrictions added.</p> <p>Page 4-11: Changes made to first heading, note, and procedure.</p> <p>Page 4-15: Unit corrected in table.</p> <p>Chapter 5: Order changed and information on control remote I/O added in several places. In addition, the following changes were made.</p> <p>Page 5-2: Changes made to first paragraph under heading.</p> <p>Pages 5-5 and 5-39: Number of poles corrected in notes.</p> <p>Page 5-15: Minor change made to first table.</p> <p>Page 5-26: Information on reading and writing parameters added.</p> <p>Page 5-27: Numerical changes made in several places and information added to table.</p> <p>Page 5-29: Minor change made to first paragraph.</p> <p>Page 5-38: Changes made to tables in several places.</p> <p>Page 6-7: Catalog number corrected.</p> <p>Chapter 7: Extensive changes made to provide examples for CS-series PCs.</p> <p>Page 8-2: Minor changes made to table.</p> <p>Page 8-11: Equations added.</p>