

DUAL ENCODER (PG) FEEDBACK CARD (PG-Z2)

INSTRUCTIONS

Upon receipt of the product and prior to initial operation, read these instructions thoroughly, and retain for future reference.

Package Contents:

Name	Part No. (Code No.)
Dual Encoder (PG) Feedback Card (PG-Z2)	PG-Z2 (73600-A0251)
Spacer	SRNT41028-9
Instructions	EZZ009533



NOTES FOR SAFE OPERATION

Before installation, operation, maintenance or inspection of this option, a technically qualified individual who is familiar with this type of equipment and the hazards involved should read this entire manual thoroughly. In this manual, the NOTES FOR SAFE OPERATION are classified as "CAUTION".



Indicates a potentially hazardous situation that, if not avoided, may result in minor or moderate injury to personnel and damage equipment. Lock all power sources feeding the drive in the "Off" position.

It may also be used to alert against unsafe practices.

Failure to heed notices labeled with  **CAUTION** may result in dangerous situations or equipment damage.



Steps to be taken to insure proper operation and to avoid malfunctions.

 Caution
<ul style="list-style-type: none">• The option card uses a CMOS IC chip. Be careful when handling.• When removing the option card from the drive for transportation or storage, the card should be placed in the anti-static package it was received in.• DO NOT alter wiring or connect or disconnect connectors while equipment power is ON. <p>Failure to observe these cautions may result in injury or equipment damage!</p>



Before use,

- (1) Before installing the PG-Z2 card, read this manual and the manual for the installation of the drive.
- (2) Before connecting the PG-Z2 or external terminals, turn OFF the main power to the drive and verify that the CHARGE indicator lamp of the Drive is OFF.
- (3) When ordering the PG-Z2 card, specify the part number and code number.

1. Inspection after Delivery



Caution

- Verify that the products received are the products ordered.
Installation of incorrect product may lead to injury or damage.

Prior to shipment, all Yaskawa products undergo rigorous inspection procedures to ensure accuracy and reliability. We recommend checking the following items upon receipt.

1. Check that the product code (73600-A0251) and part number (PG-Z2) labeled on the actual card correspond to product ordered.
2. Check for damage caused during transportation.
3. Report any damages or shortages to the commercial carrier who transported the products.

Report any material or manufacturing defects on the card to your Yaskawa representative.

2. Introduction

The Dual Encoder (PG) Feedback Card (PG-Z2) (Figure 1) is mounted on the drive's control board to provide speed and direction feedback from two encoders. The drive's control logic can use this information for purposes such as correcting for speed fluctuation caused by motor slip, maintaining the velocity and phase relationship between two machine (motor) shafts, and aligning a spindle at stop for tool changing.

Using standard software, the PG-Z2 can be used for closed loop control (Flux Vector or V/F with PG) of one or two motors. The second motor is selected by using a multi-function digital input programmed for "Motor 2 Select". Standard software does not utilize the marker (C or Z) pulse from the encoder.

Custom software titles such as Electronic Line Shaft, and others utilize the PG-Z2 card. The configuration varies so please consult the specific software technical manual. The marker pulse may be needed depending on the software.

The PG-Z2 option card is compatible with the F7 and G7 Yaskawa drives. The G5 is not compatible and uses the PG-W2 option card instead.

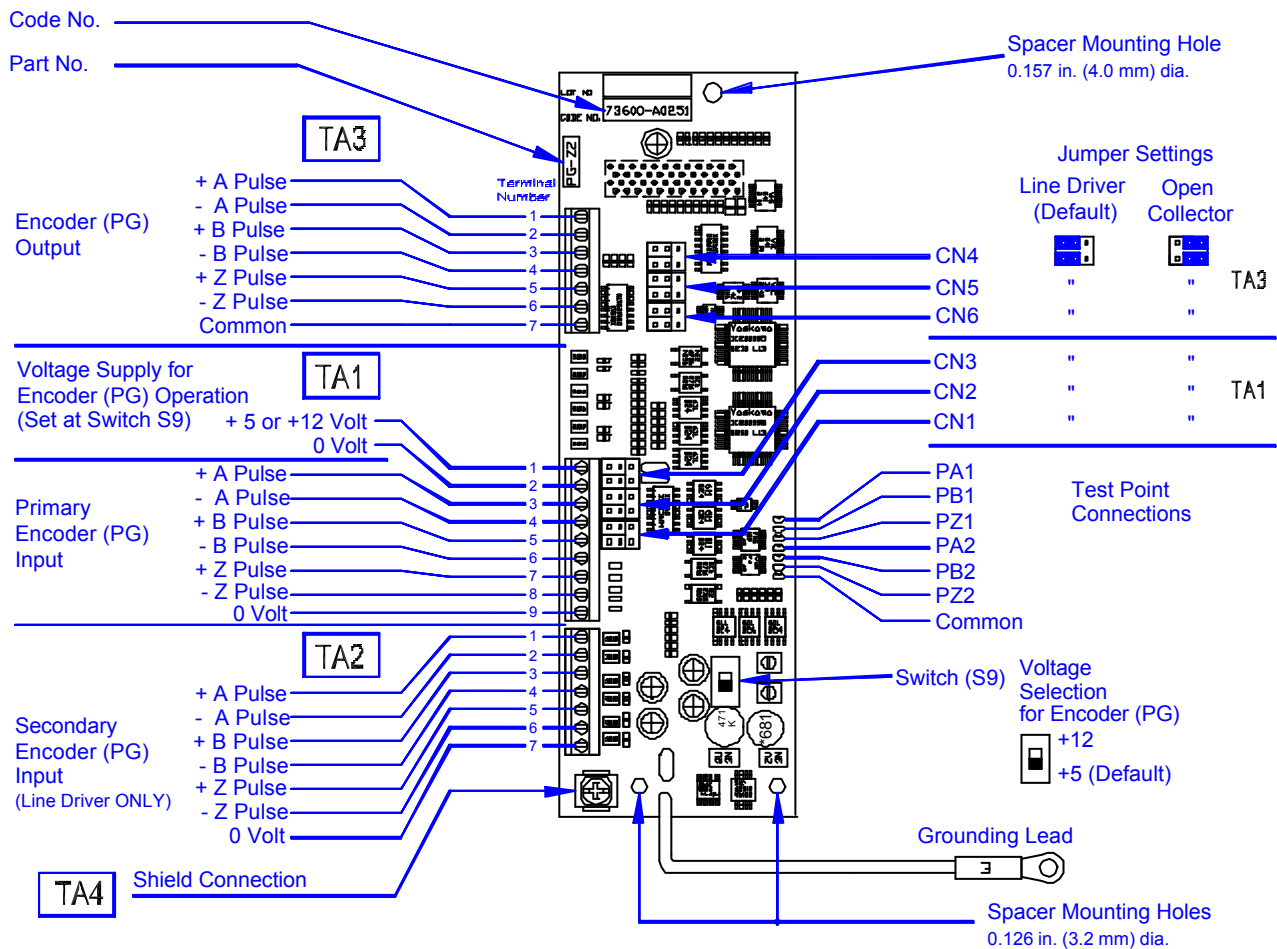

Figure 1. Dual Encoder (PG) Feedback Card (PG-Z2)

3. Configuring the PG-Z2



The PG-Z2 option card was designed to combine several older option cards and has user and software programmable features. These features must be set correctly for your application in order to operate properly.

3.1 PG-Z2 Configuration

- (1) Carefully remove the option card from the static bag following procedures for safe handling of static sensitive devices.
- (2) Verify that the correct option card has been received by matching the code and part numbers on the card with your order.
- (3) Use Figure 1 to locate the following components.
- (4) Set jumpers CN1 thru CN3 to either line driver (default) or open collector depending on your encoder requirements. This sets the **input** type to the PG-Z2 on terminal TA1. The second encoder input, TA2, is fixed to a line driver type encoder.
- (5) Set voltage supply switch (S9) to the voltage required to operate your encoder (PG). **Default is 5 volts**. Maximum current available for encoder (PG) operation is 200mA. Check your encoder (PG) manual for your encoder's (PG) requirements. When supplying power to two encoders using the PG-Z2, ensure that the total current is less than 200mA.

3.2 Terminal block TA3 is the encoder output, which passes through one of the two encoder inputs with no delay (less than 1 microsecond). Using standard software, the output is fixed to pass through the primary encoder input. When using custom software, there may be a software parameter to select which encoder to output. Check the specific custom software manual for details.

- (1) Set jumpers CN4 thru CN6 to either line driver (default) or open collector depending on your system requirements. This sets the **output** type from the PG-Z2 on terminal TA3.

4 Installation Procedure



It is necessary to install **and** wire option cards to positions C and D (See Figure 3), prior to installing the PG-Z2 option.

4.1 Drive Installation Procedure

- (1) Remove contents from package and verify that a mounting spacer (code number SRNT41028-9) is included with the card (see Figure 2).

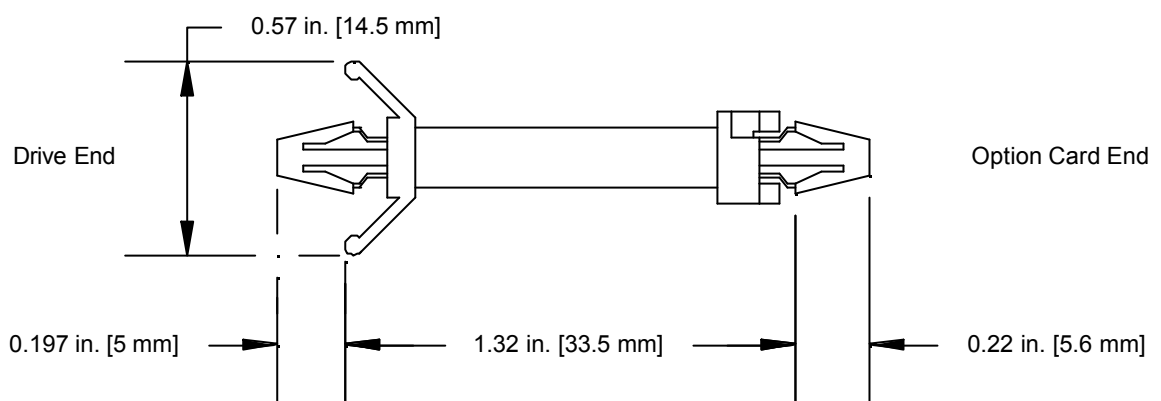

Figure 2. Spacer

- (2) Turn OFF the main power and wait for the time specified on the cover of the Drive for voltage to bleed off the DC bus capacitors. Remove the cover and verify that the CHARGE indicator lamp is OFF.
- (3) Insert the spacer (SRNT41028-9) into the spacer mounting hole in the mounting base of the Drive, just above the top edge of the control board (see Figure 3). Some Drive models have two closely spaced mounting holes. Insert the spacer into the hole closest to the 7CN connector on the control board. Insertion of the spacer into the incorrect hole WILL NOT provide proper alignment with the option card's mounting hole.
- (4) Position the bottom edge of the option card into the mounting bracket on the control board's terminal block. Align the two (2) mounting holes in the card with the pins on the bracket.
- (5) Rotate the top edge of the card down into place, carefully aligning connector 4CN on the back of the card with connector 4CN on the control board.
- (6) Gently press the card into place until 4CN and the spacer click into place.
- (7) Connect the green ground wire to the grounding terminal on the control board.

4 Installation Procedure (cont'd)

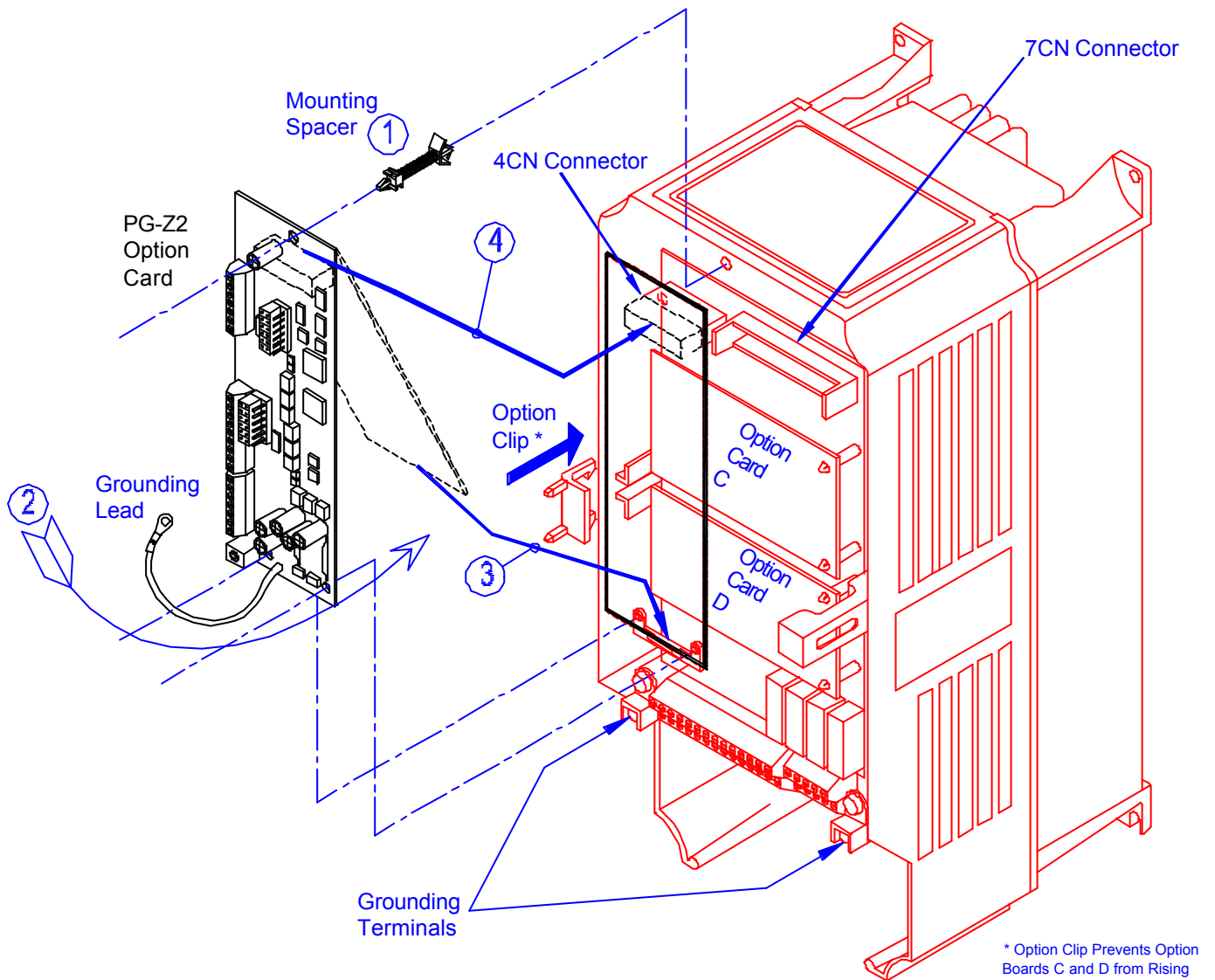

Figure 3. Installation of Dual Encoder (PG) Card (PG-Z2)

CAUTION

Be sure the PG wiring is clear of the enclosure when reinstalling the cover.

5 Interconnection

Figure 4 shows interconnection between the Drive, PG-Z2, and peripheral equipment, using standard Drive software.

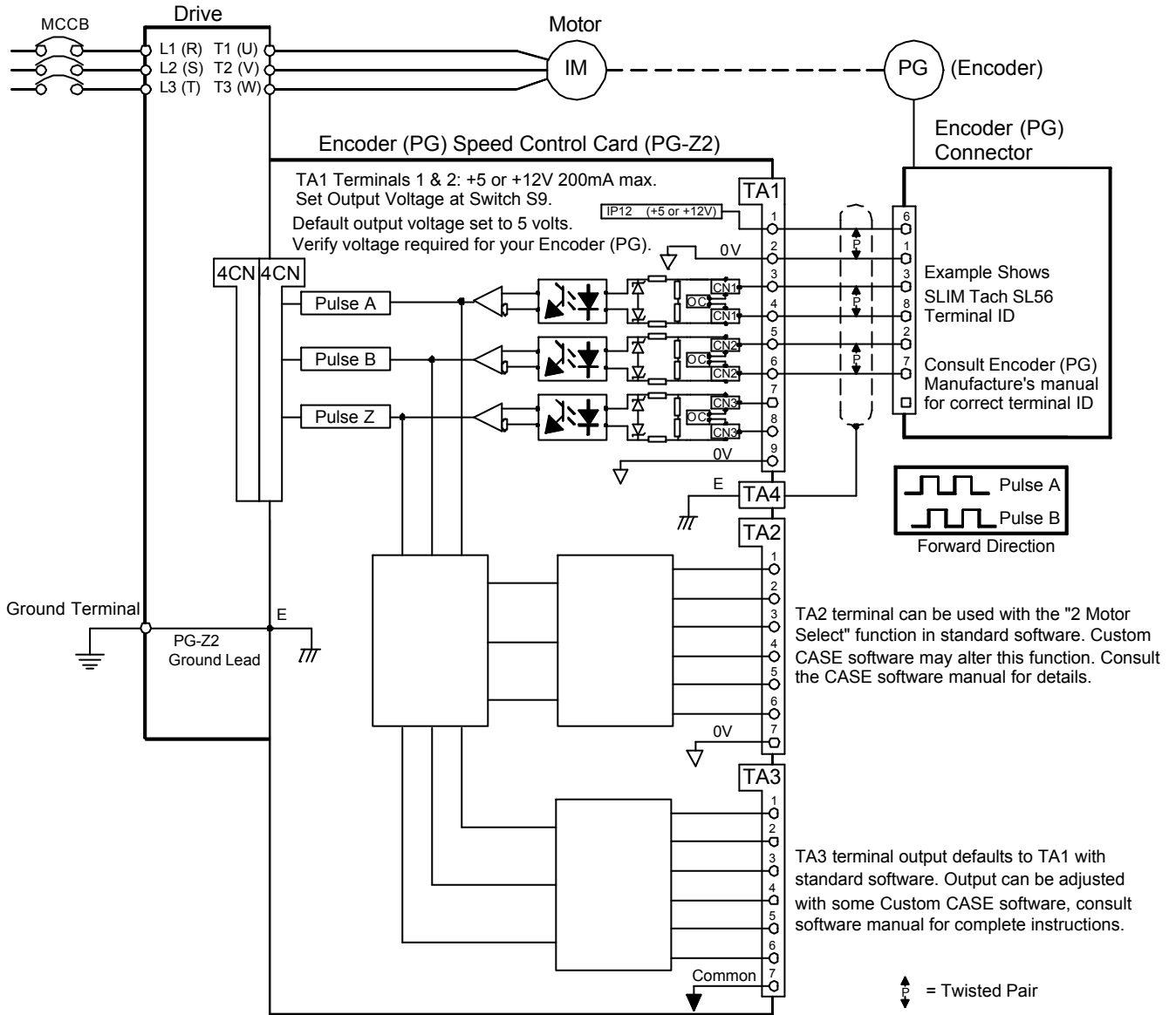

Basic Encoder PG Feedback Card (PG-Z2) Interconnection Diagram

For Dual Encoder Connections Consult Software Manual

6 Wiring

Note

Important: Check the power supply requirements of your encoder (PG) and set the S9 switch on the PG-Z2 card accordingly. Default setting is 5 volts. See Table 1.

Terminal block symbol	Pin No.	Functions		
TA1	1	+ 5 or +12V	Power supply for Encoder (PG). Set at Switch S9 200mA maximum +5V (Default)	
	2	0V		
	3	+		
	4	-	A Pulse	Encoder (Pulse generator, PG) signal input. Signal type determined by CN1-3.
	5	+	B Pulse	
	6	-	Z Pulse*	
	7	+		
	8	-		
	9	0V		
TA2	1	+	A Pulse	Secondary encoder (pulse generator, PG) input. Line driver only.
	2	-	B Pulse	
	3	+		
	4	-	Z Pulse*	Signal input RS-422 Level.
	5	+		
	6	-		
	7	0V		
TA3	1	+	A Pulse	Encoder (Pulse generator, PG) signal output. Signal type determined by CN-4-6.
	2	-	B Pulse	
	3	+		Z Pulse*
	4	-		
	5	+		
	6	-		
	7	Common		
TA4	Shielded sheath connection terminal			

* Not required for standard software. May be required for custom software.

Table 1. Terminal Functions of PG-Z2

Terminal Symbol	Terminal Screw	Clamping Torque Lb-in (N-m)	Wire Range AWG (mm ²)
TA1, TA2, TA3	M2	1.8 to 2.2 (0.22 to 0.25)	26 to 16 (Stranded: 0.14 to 1) (Solid: 0.14 to 1.5)

Table 2. Terminal and Wire Specification

6 Wiring (Cont'd)

Note

Make sure of the following when wiring:

- Separate the control signal wires (terminals TA1, TA2, and TA3) of the PG-Z2 from the main circuit wires and other power cables.
- A separate metallic grounded conduit with the PG wiring ONLY is preferred to prevent the introduction of noise on encoder (PG) signals.
- Use a shielded wire to connect the encoder (PG). Connect the wires as shown in Figure 5 to prevent noise interference. The wire distance must be 164 ft. (50m) or less.
- Be sure the PG wiring is clear of the enclosure when reinstalling the cover.

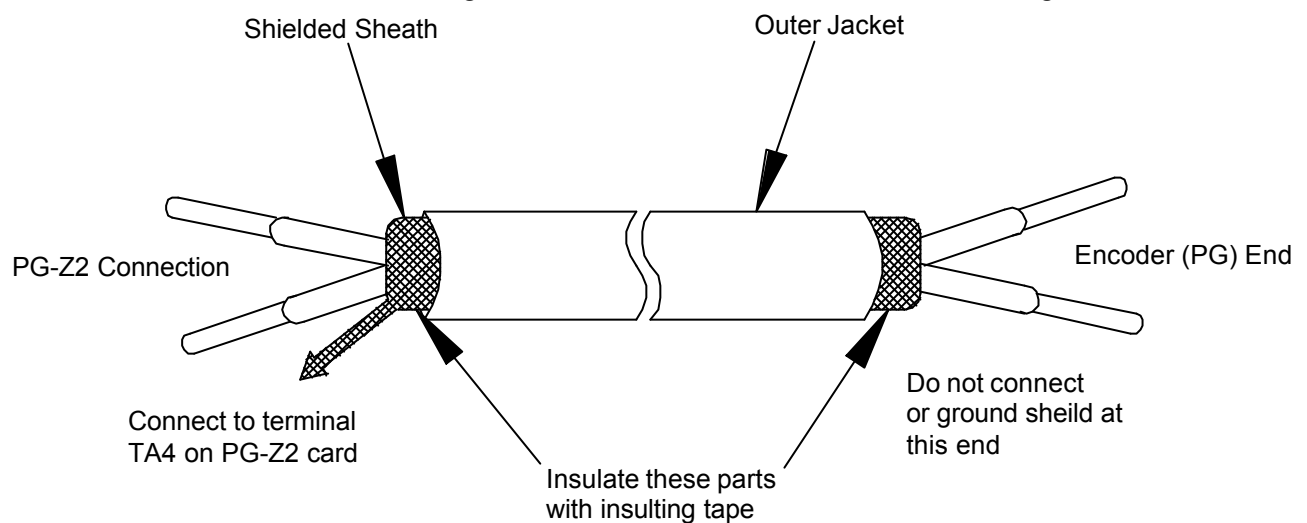

Figure 5. Shielded wire termination

	(mm ²)	AWG	I (amps)	VAC
Thin	1	16	12	125
Solid Wire	1.5	16	12	125
UL	-	22-16	10	300
CSA	-	28-16	10	300
CSA	-	28-16	10	150

(Terminal: MKDS1 series manufactured by Phoenix Contact GmbH & Co.)

Table 3. Wire specification

6 Wiring (Cont'd)

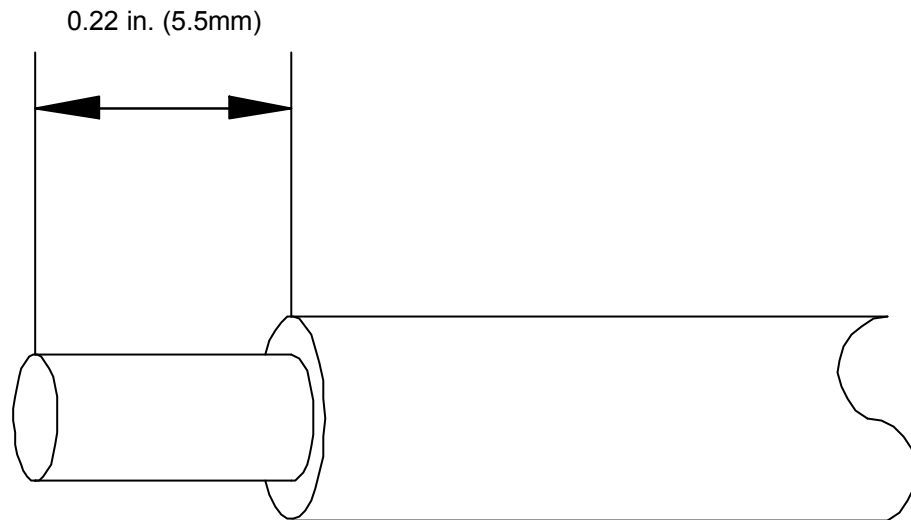

Insulation Stripping Length
for Terminals TA1, TA2, TA3
of PG-Z2 Option Card

- Strip back insulation for a distance of 0.22 inches (5.5mm) on wire leads connected to the PG-Z2

Note

Notes on selecting cables

Cable that is too thick will apply pressure to the option card and may lead to failure.

Cable that is too thin will produce poor electrical contact and conductor may break.

7 Application of Encoder (PG)

The maximum frequency of the encoder (PG) output pulses that can be detected in Line Driver mode is 300kHz. In Open Collector mode the pulse limit is 32kHz. To find the output frequency of your encoder (PG), use the following formula.

$$f_{PG} \text{ (Hz)} = \frac{\text{Motor rotation speed (r/min) at max. frequency output}}{60} \times \text{Encoder (PG) constant (pulses/rev)}$$

To convert to kHz divide the result in Hz by 1000.

Maximum power available to drive the encoder (PG) with the PG-Z2 is 200mA. Should your encoder (PG) require more than 200mA, it will be necessary to provide a separate power supply. See Figure 6.

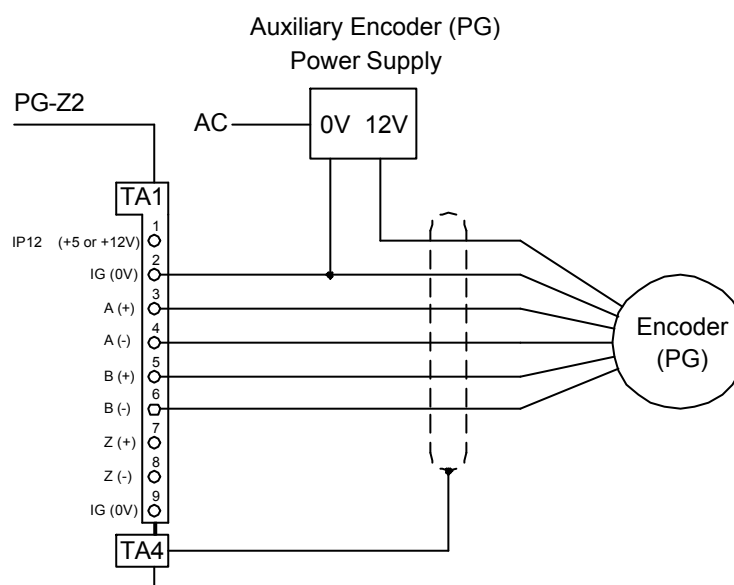

Figure 6. Connection example with encoder (PG) when using separate power supply

The PG-Z2 card requires a “quadrature” with “compliments” type signals from the encoder (PG).

Quadrature Signal

A quadrature signal is one that lags the primary signal by 90 electrical degrees ($\frac{1}{2}$ a pulse). This gives the Drive the capability to detect the rotational direction of the motor shaft. As shown in Figure 7, for “forward” rotation (C.C.W.), the rise of signal A+ will lead the rise of signal B+ by 90°.

7 Application of Encoder (PG), (cont'd)



All signals shown are taken in relation to power supply common, Pin 2 of the PG-Z2 card.

Complimentary Signal

A complimentary signal includes both a primary signal (A+) and it's inverse (A-). See Figure 7. This scheme improves the noise immunity of the feedback because the two signals are combined in the PG-Z2 providing double the voltage level difference from low to high signal levels. For example, a +12V encoder has a low voltage level of 0V and a high voltage level of +24V as measured by the PG-Z2.

The A and B quadrature signals each have their own compliment and if any one of the four signals is missing, the drive cannot accurately detect encoder (PG) speed or direction.

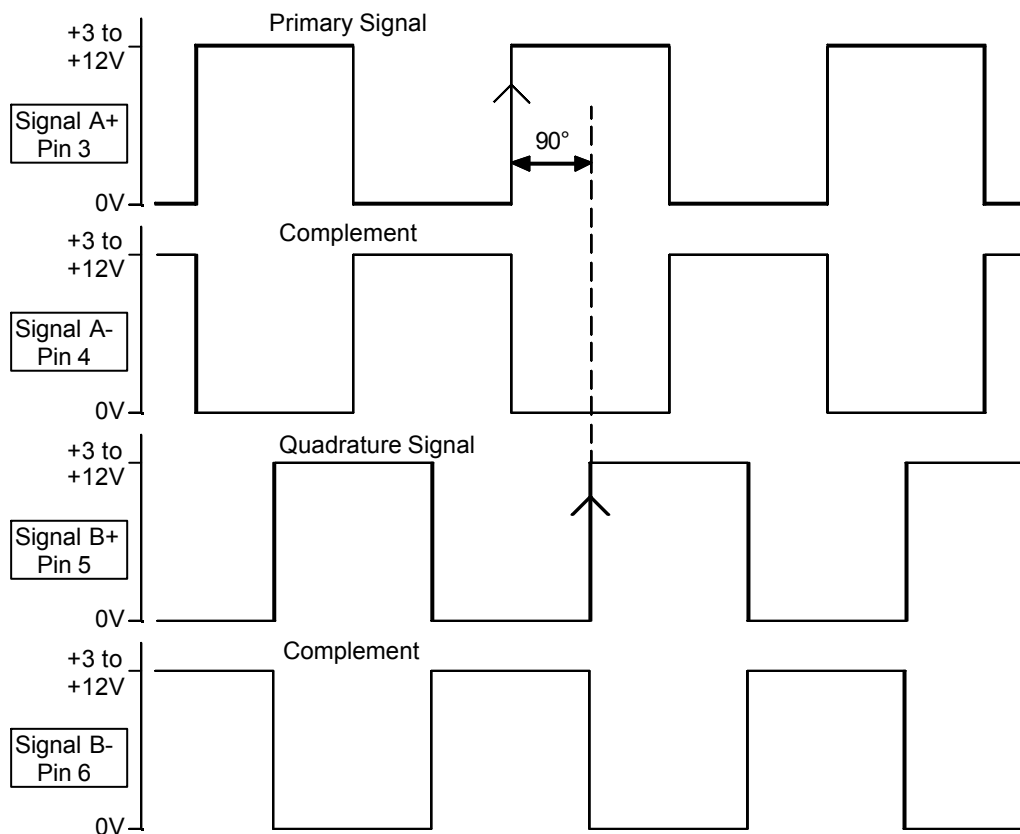

Figure 7. Encoder (PG) Signals – Forward Direction (C.C.W.)

8 Encoder (PG) Speed Control (PG-Z2) Parameter List

Encoder (PG) Speed Control (PG-Z2) Parameter List												
Digital Operator Function Group	Digital Operator Display	Parameter No.	Parameter Name	Setting Range	Factory Setting	Change During Operation (2)	Data Selection	Control Method (3)				
								V/f Control	V/f w/PG Fdbk	Open loop Vector	Flux Vector	Open loop Vector 2
PG Option Setup	PG Pulse/Rev	F1-01	PG Constant	0 to 60000	1024	X		X	O	X	O	X
	PG Fdbk Loss Sel	F1-02	Operation at PG open circuit	0 to 3	1	X	0: Ramp to Stop	X	O	X	O	X
	PG Overspeed Sel	F1-03	Operation selection at overspeed	0 to 3	1	X	1: Coast to Stop 2: Fast-Stop 3: Alarm Only	X	O	X	O	X
	PG Deviation Sel	F1-04	Operation selection at deviation	0 to 3	3	X		X	O	X	O	X
	PG Rotation Sel	F1-05	PG rotation	0,1	0	X	0: Fwd=CCW 1: Fwd=CW	X	O	X	O	X
	PG Ramp PI/I Sel	F1-07	Integral value during accel/decel enable/disable	0,1	0	X	0: Disabled 1: Enable	X	O	X	X	X
	PG Overspeed Level	F1-08	PG overspeed detection level	0 to 120%	115%	X		X	O	X	O	X
	PG Overspeed Time	F1-09	PG overspeed detection delay	0 to 2.0s	1.0s	X		X	O	X	O	X
	PG Deviation Level	F1-10	Excessive speed deviation detection level	0 to 50%	10%	X		X	O	X	O	X
	PG Deviation Time	F1-11	Excessive speed deviation detection delay time	0 to 10s	0.5s	X		X	O	X	O	X
	PG# Gear Teeth 1	F1-12	No. of gear teeth 1	0 to 1000	0	X		X	O	X	X	X
	PG# Gear Teeth 2	F1-13	No. of gear teeth 2	0 to 1000	0	X		X	O	X	X	X
	PGO Detect Time	F1-14	PGO detection time	0 to 10s	2sec	X		X	O	X	O	X
	Speed Detection Filter Selection (F7 only)	F1-15	Speed detection filter selection	0,1	1	X	0: No moving AVG 1: 2 moving AVG	X	O	X	O	X
	ASR Tuning (1)	ASR P Gain 1	C5-01	ASR proportional gain 1	0 to 300.00	0.00	O		X	O	X	O
ASR I Time 1		C5-02	ASR integral time 1	0 to 10.000s	0.00s	O		X	O	X	O	X
ASR P Time 2		C5-03	ASR proportional gain 2	0 to 300.00	0.00	O		X	O	X	O	X
ASR I Time 2		C5-04	ASR integral time 2	0 to 10.000s	0.00s	O		X	O	X	O	X
ASR Limit		C5-05	ASR Limit	0.0 to 20%	0.0%	X		X	O	X	X	X
ASR Delay Time		C5-06	ASR primary delay time	0.000 to 0.500s	0.000s	X		X	X	X	O	X
ASR Gain SW Freq		C5-07	ASR switching freq	00 to 400.00Hz	0.0Hz	X		X	X	X	O	X
ASR Integral Limit		C5-08	ASR Integral limit	0 to 400%	400%	X		X	X	X	O	X

(1) ASR - Automatic Speed Regulator

(2) O = Enable, X = Disable

(3) O = Setting enable, X = Setting disable, open loop vector 2 is only available in G7.