

Varispeed G7/F7 OPTION CARD
MECHATROLINK COMMUNICATIONS INTERFACE CARD
USER'S MANUAL

Model: SI-T

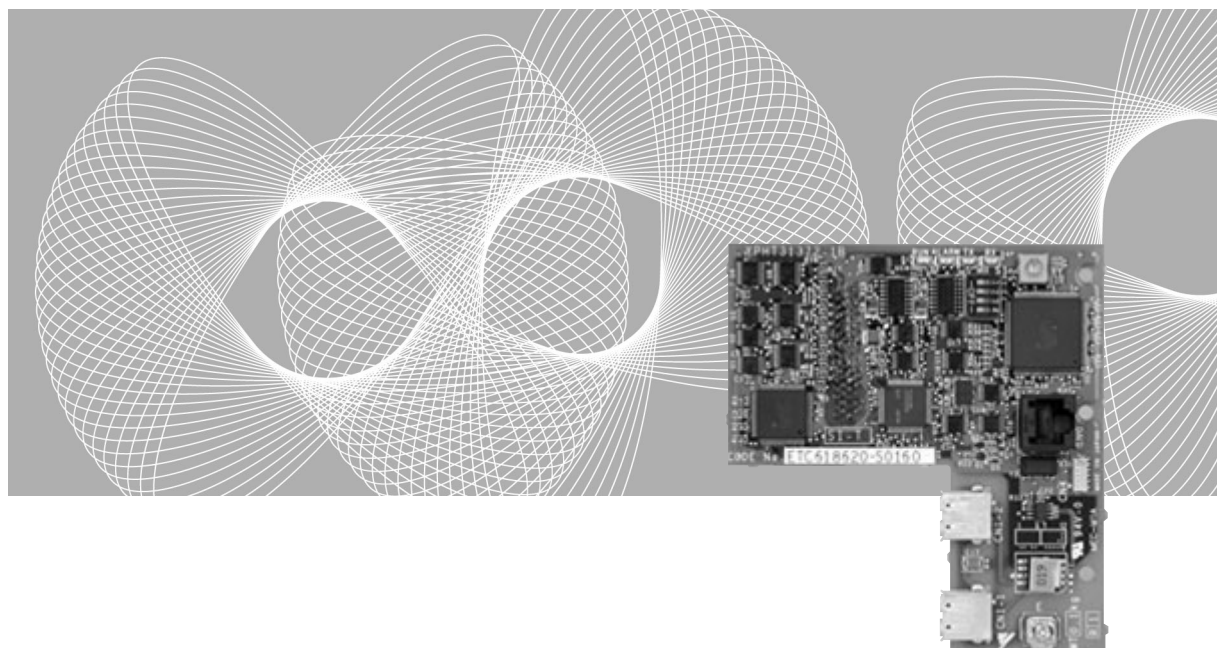

YASKAWA

MANUAL NO. SIBP C730600 08A

Copyright © 2004 YASKAWA ELECTRIC CORPORATION

All rights reserved. No part of this publication may be reproduced, stored in a retrieval system, or transmitted, in any form, or by any means, mechanical, electronic, photocopying, recording, or otherwise, without the prior written permission of Yaskawa. No patent liability is assumed with respect to the use of the information contained herein. Moreover, because Yaskawa is constantly striving to improve its high-quality products, the information contained in this manual is subject to change without notice. Every precaution has been taken in the preparation of this manual. Nevertheless, Yaskawa assumes no responsibility for errors or omissions. Neither is any liability assumed for damages resulting from the use of the information contained in this publication.

Introduction

Thank you for purchasing a Current Vector Control General-purpose Varispeed G7/F7 Inverter and a SI-T MECHATROLINK-I/MECHATROLINK-II Communications Interface Card (called “SI-T Card” below).

This manual describes the operation and specifications of the SI-T Card, which connects to the MECHATROLINK-I/MECHATROLINK-II high-speed field network for exchanging data. Be sure that you have read and understood this manual before attempting to operate the SI-T Card.

For details on operating the Inverter itself, refer to the Varispeed G7/F7 Series Instruction Manual (TOE-S616-60.1, TOE-S616-55.1).

Yaskawa Electric, Inc.

General Precautions

- The diagrams in this manual may be indicated without covers or safety shields in order to show details. Be sure to restore covers or shields before operating the Inverter, and operate the Inverter according to the instructions provided in this manual.
- The products and specifications described in this manual or the contents and presentation of the manual may be changed without notice to improve the product and/or the manual.
- When ordering a new copy of the manual due to damage or loss, contact your Yaskawa representative or the nearest Yaskawa sales office and provide the manual number shown on the front cover.
- Any modifications to the product by the customer invalidate the warranty, and Yaskawa accepts no responsibility for the results of any modifications

Safety Precautions

Carefully read this manual and all other documentation provided with the product before attempting to install, operate, inspect, or perform maintenance on the product. Within this manual, safety-related precautions are classified a “warnings” and “cautions.”



Indicates precautions that, if not heeded, could possibly result in loss of life or serious injury.



Indicates precautions that, if not heeded, could result in relatively less serious or minor injury, or damage to the equipment.

Failure to heed even a precaution classified as a caution can result in serious consequences depending on the situation. All precautions contain important information, so make sure that they are followed carefully.

IMPORTANT

Indicates important information that the user should make careful note of, even though it is not classified as a caution.

■ Confirmations upon Delivery

CAUTION

- Never use an Option Card that is damaged or missing components.
Doing so can result in injury.

■ Installation and Wiring

WARNING

- Never touch the inside of the Inverter with your hands.
Doing so can result in electric shock.
- Before installing or removing the Option Card, or performing wiring operations, always turn OFF the power to the Inverter and wait until the specified period of time has elapsed after all the Inverter indicators have turned OFF. (The time is shown on the Inverter's front cover.)
Failure to do so can result in electric shock.
- Do not allow cables to be damaged, subjected to stress, placed under heavy objects, or pinched.
Doing so can result in electric shock, faulty operation, or damage to the equipment.

CAUTION

- Never touch the Option Card terminals directly with your hands.
Doing so can result in damage from static electricity.
- Insert the connectors securely.
Failure to do so can result in damage or faulty operation of devices.

■ Settings

CAUTION

- Do not carelessly change the Inverter's settings.
Doing so can result in damage or faulty operation of devices.

Warranty Information

■ Free Warranty Period and Scope

■ Warranty Period

This product is warranted for twelve months after being delivered to Yaskawa's customer or if applicable eighteen months from the date of shipment from Yaskawa's factory, whichever comes first.

■ Scope of Warranty

Inspections

Periodic inspections must be conducted by the customer. However, upon request, Yaskawa or one of Yaskawa's Service Centers can inspect the product for a fee. In this case, if after conferring with the customer, a Yaskawa product is found to be defective due to Yaskawa workmanship or materials and the defect occurs during the warranty period, then this fee will be waived and the problem remedied free of charge.

Repairs

If a Yaskawa product is found to be defective due to Yaskawa workmanship or materials and the defect occurs during the warranty period, Yaskawa will provide a replacement, repair the defective product, and provide shipping to and from the site free of charge.

However, if the Yaskawa Authorized Service Center determines that the problem with a Yaskawa product is not due to defects in Yaskawa's workmanship or materials, then the customer will be responsible for the cost of any necessary repairs. Some problems that are outside the scope of this warranty are:

- Problems due to improper maintenance or handling, carelessness, or other reasons where the customer is determined to be responsible.
- Problems due to additions or modifications made to a Yaskawa product without Yaskawa's understanding.
- Problems due to the use of a Yaskawa product under conditions that do not meet the recommended specifications.
- Problems caused by natural disaster or fire.
- Or other problems not due to defects in Yaskawa workmanship or materials.

Warranty service is only applicable within Japan.

However, after-sales service is available for customers outside of Japan for a reasonable fee. Contact your local Yaskawa representative for more information.

■ Exceptions

Any inconvenience to the customer or damage to non-Yaskawa products due to Yaskawa's defective products whether within or outside the warranty period are NOT covered by this warranty.

Restrictions

- The SI-T Card was not designed or manufactured for use in devices or systems that may directly affect or threaten human lives or health.
- Customers who intend to use the product described in this manual for devices or systems relating to transportation, health care, space aviation, atomic or electric power, or underwater use must contact their Yaskawa representatives or the nearest Yaskawa sales office beforehand.
- This product has been manufactured under strict quality-control guidelines. However, if this product is to be installed in any location where failure of this product could involve or result in a life-and-death situation or loss of human life or in a facility where failure may cause a serious accident or physical injury, safety devices must be installed to minimize the likelihood of any accident.

CONTENTS

Introduction	3
Safety Precautions	4
Warranty Information	6
Restrictions	7
1 Overview	10
2 Checking the Product	10
2.1 Type and Code No.	10
2.2 Parts List	11
3 Component Names and Settings	11
3.1 Component Names	11
3.2 Communications Connectors	12
3.3 LED Indicators	12
3.4 Switch Setting	13
4 Installation and Wiring	15
4.1 Installing the SI-T Card	15
4.2 MECHATROLINK Communications Cables	17
5 Transmission Interface	18
5.1 MECHATROLINK-II Cyclic Transmissions	18
5.2 Basic Format of Data Transfer	19
5.3 Communications Phases	20
5.4 Application Layer Specifications	21
6 Initial Setup	22
7 MECHATROLINK-II Commands	23
7.1 Main Commands	23
7.2 Sub-commands	37
7.3 Status Details	42
8 Protective Operations	44
8.1 Fault Detection Processing	44
8.2 Alarm Processing	45

9 Specifications ----- 50

Revision History

1 Overview

The SI-T Card is an interface card that connects to the MECHATROLINK-I or MECHATROLINK-II high-speed field network for communicating with the host controller.

By installing the SI-T Card to a Varispeed G7/F7-series Inverter, various applications are enabled; monitoring of the run/stop status and the operating conditions as well as the changing and the referencing of the settings for the Inverter constants from the host controller.

The SI-T Card can be installed in the following Inverters.

- Varispeed G7-series Inverter, software No. 656X.
- Varispeed F7-series Inverter (SPEC:E or later), software No.103X.

Note: "X" indicates the design revision order.

IMPORTANT

Varispeed G7/F7 Inverter with an SI-T Card does not conform to CE Marking, although the Varispeed G7/F7 Inverter itself conforms to CE Marking.

2 Checking the Product

Check the following items as soon as the product is delivered.

Item	Method
Is there any discrepancy between the shipment and what was ordered?	Check the type and code No. printed on the center of the Card. (Refer to 2.1 and 3.1.)
Has the product been damaged in any way?	Inspect the entire exterior of the Card for any damage that may have occurred during shipping.
Are the contents of the package correct?	Check the contents shown in the following table. (Refer to 2.2.)

Contact your Yaskawa representative immediately if any failure should be found concerning the above items.

2.1 Type and Code No.

The following shows the type and code No. on the center of the SI-T Card.

Type: SI-T

Code No.: ETC61862X-S016X

Note: "X" indicates the design revision order.

2.2 Parts List

The SI-T Card contains the following parts.

Parts Name	Qty
SI-T Communications Interface Card	1
Grounding cable (Already mounted on the SI-T Card)	1
Instruction Manual (This manual)	1

3 Component Names and Settings

3.1 Component Names

The following diagram shows the SI-T Card external appearance and component names.

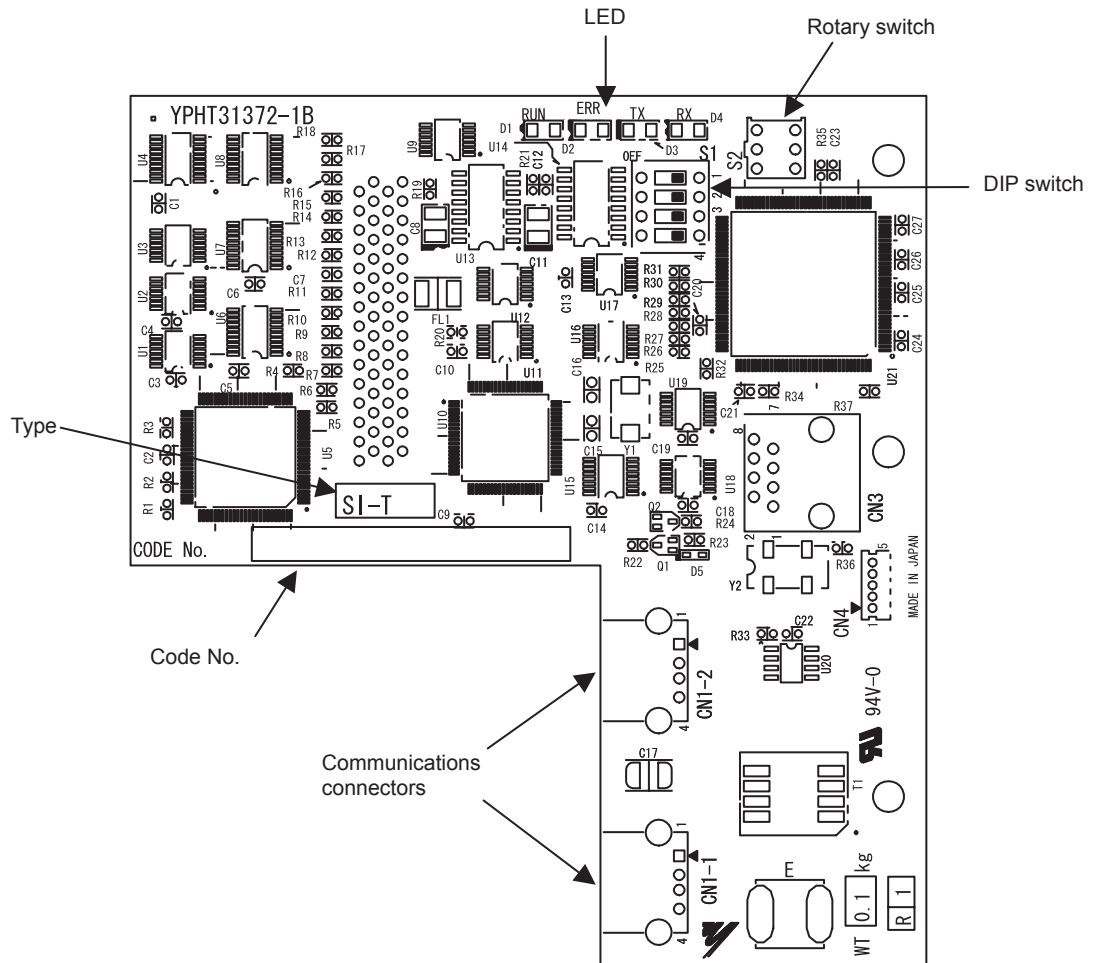

3.2 Communications Connectors

The communications connectors (CN1-1 and CN1-2) connect the SI-T Card to the communications lines of the MECHATROLINK-I or MECHATROLINK-II. The following table shows the pin numbers and their functions.

Connector	Pin No.	Signal Name	I/O	Function
CN1-1	1	(NC)	–	Not used.
	2	SRD–	I/O	Send/receive data (-)
	3	SRD+	I/O	Send/receive data (+)
	4	(NC)	–	Not used.
	Shell	Shield	–	Not used.
CN1-2	1	(NC)	–	Not used.
	2	SRD–	I/O	Send/receive data (-)
	3	SRD+	I/O	Send/receive data (+)
	4	(NC)	–	Not used.
	Shell	Shield	–	Not used.

3.3 LED Indicators

The LED indicators indicate the status of the communications of the MECHATROLINK-I or MECHATROLINK-II and the SI-T Card.

However, these indicators are for maintenance checks at Yaskawa. Use the Digital Operator to check the status.

Name	Display		Explanation
	Color	Status	
RUN	Green	Lit	Normal operation
	–	Not lit	Communications CPU stopped, resetting hardware, RAM check error, DPRAM check error, station address setting error, or Inverter model code error
ERR	Red	Lit	Watchdog timeout error, communications error, diagnosis error, or resetting hardware
	Red	Blinking	ROM check error (once)*, RAM check error (twice)*, DPRAM check error (3 times)*, communications ASIC self-diagnosis error (4 times) *, ASIC RAM check error (5 times)*, station address setting error (6 times) *, Inverter model code error (7 times) * *: Indicates the number of blinking.
	–	Not lit	No communications error or self-diagnosis error
TX	Green	Lit	Sending data
	–	Not lit	Sending of data stopped, hardware reset
RX	Green	Lit	Searching for receiving carrier
	–	Not lit	No receiving carrier found, resetting hardware

3.4 Switch Setting

■ DIP Switch

The following table shows the SI-T Card DIP switch settings.

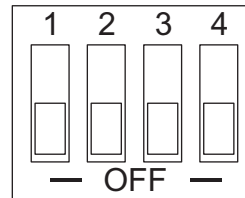

Name	Label	Status	Function	Factory Setting
Baud rate	S1-1	OFF	4 Mbps (MECHATROLINK-I)* ¹	ON
		ON	10 Mbps (MECHATROLINK-II)	
Data length	S1-2	OFF	17-byte data transmission (MECHATROLINK-I/ MECHATROLINK-II)	ON
		ON	32-byte data transmission (MECHATROLINK-II)* ¹	
Station address	S1-3	OFF	Set the 10's digit of the station number to 2. Invalid if the maximum number of units including the S2 of the rotary switch is 20.	OFF
		ON	Set the 10's digit of the station number to 3. Invalid if the maximum number of units including the S2 of the rotary switch is 3F.	
Maintenance	S1-4	OFF	Normally OFF* ²	OFF
		ON	Not used.	

* 1. Invalid if S1-1 is OFF (4 Mbps) and S1-2 is ON (32-byte data transmission).

* 2. For maintenance. Always leave this switch OFF.

■ Rotary Switch

The following table shows the SI-T Card rotary switch settings.

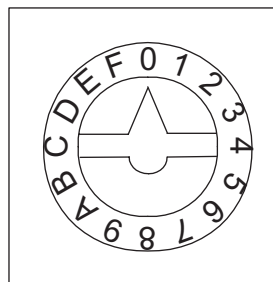

Label	Status	Function	Factory Setting
S2	0 to F	Set the 1's digit of the station number: X0H-XFH. Invalid if the maximum number of units including the S1-3 is 20 or 3F.	1

Note: Although the range that can be set by S1-3 and S2 is from 20 to 3F, 20 and 3F are invalid (the ERR LED indicator blinks six times). Therefore, the actual setting range is from 21 to 3E. Refer to the following section *Station-number Setting* for details.

■ Station-number Setting

A station number is set by both the S1-3 DIP switch and the S2 rotary switch. Station numbers from 21 to 3E are valid. Although 20 or 3F can be set as a station number, do not use these settings because they will be faulty.

S1-3: Set the 10's digit of the station number.

OFF = 2 (2X)

ON = 3 (3X)

S2: Set the 1's digit of the station number.

0 = 0 (X0)

1 = 1 (X1)

· ·

· ·

F = F (XF)

Switch Setting and Station Number

S1-3	S2	Station Number	S1-3	S2	Station Number
OFF	0	Fault	ON	0	30
OFF	1	21	ON	1	31
OFF	2	22	ON	2	32
OFF	3	23	ON	3	33
OFF	4	24	ON	4	34
OFF	5	25	ON	5	35
OFF	6	26	ON	6	36
OFF	7	27	ON	7	37
OFF	8	28	ON	8	38
OFF	9	29	ON	9	39
OFF	A	2A	ON	A	3A
OFF	B	2B	ON	B	3B
OFF	C	2C	ON	C	3C
OFF	D	2D	ON	D	3D
OFF	E	2E	ON	E	3E
OFF	F	2F	ON	F	Fault

4 Installation and Wiring

WARNING

- Before installing or removing the Option Card, or performing wiring operations, always turn OFF the power to the Inverter and wait until the specified period of time has elapsed after all the Inverter indicators have turned OFF. (The time is shown on the Inverter's front cover.)

Failure to do so can result in electric shock.

IMPORTANT

Route the MECHATROLINK communications cables separately from the main circuit wiring and other power lines.

4.1 Installing the SI-T Card

Use the following procedure to mount the SI-T Card after removing the Inverter's Digital Operator and front cover.

1. Turn OFF the Inverter's main-circuit power supply.
2. Confirm that all the indicators on the Inverter have turned OFF, wait until the specified period of time has elapsed (the time is shown on the Inverter's front cover), and then remove the Digital Operator and the front cover. Verify that the CHARGE lamp is unlit.
3. Remove the Option Clip (the clip to secure option C or D) on the Inverter. The Clip can be easily pulled out by pinching its projections.
4. Install the SI-T Card on the option C connector 2CN (60 pins) on the Inverter control board. Secure the Card by inserting the spacers on the control board into the spacer mounting holes (three holes) of the Card until hearing a "click." (Refer to A in Fig.1.)

Note: The SI-T Card (option C) and option D cannot be used at the same time.

5. Insert the Option Clip to its original position.
6. Connect the Card grounding cable to the control circuit terminal E (G) on the Inverter control board.
7. After the Card is installed, connect the communications cables and set the DIP switches. (Refer to 3.4 and 4.2.)
8. Remount the Digital Operator and the front cover.

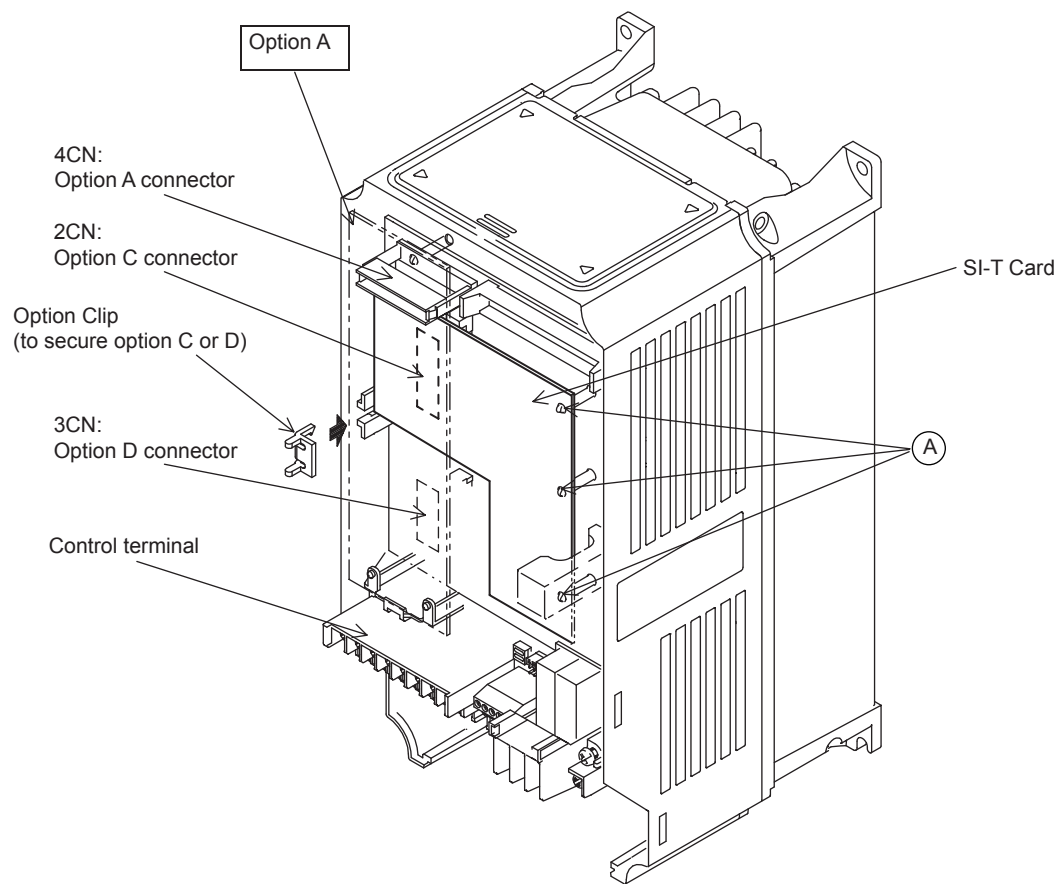

Fig. 1 Installation of the SI-T Card

4.2 MECHATROLINK Communications Cables

■ Wiring

Wire the MECHATROLINK communications cables to the communications connector (CN2).

IMPORTANT

- For communications cables, use special shielded twisted-pair cables for MECHATROLINK communications.

Recommended cable: JEPMC-W603-□□ *

* □□ is the length (m).

With USB connector with core

- Install MECHATROLINK communications cables apart from main-circuit wiring and other electrical and power lines
- Connect the terminator (model No.: JEPMC-W6022) on the end of the communication lines.
- Maximum transmission distance is 50 m.
- Minimum wiring distance between stations is 0.5 m.

■ Communications Wiring Example

The following diagram is an example of communications wiring around the Inverters.

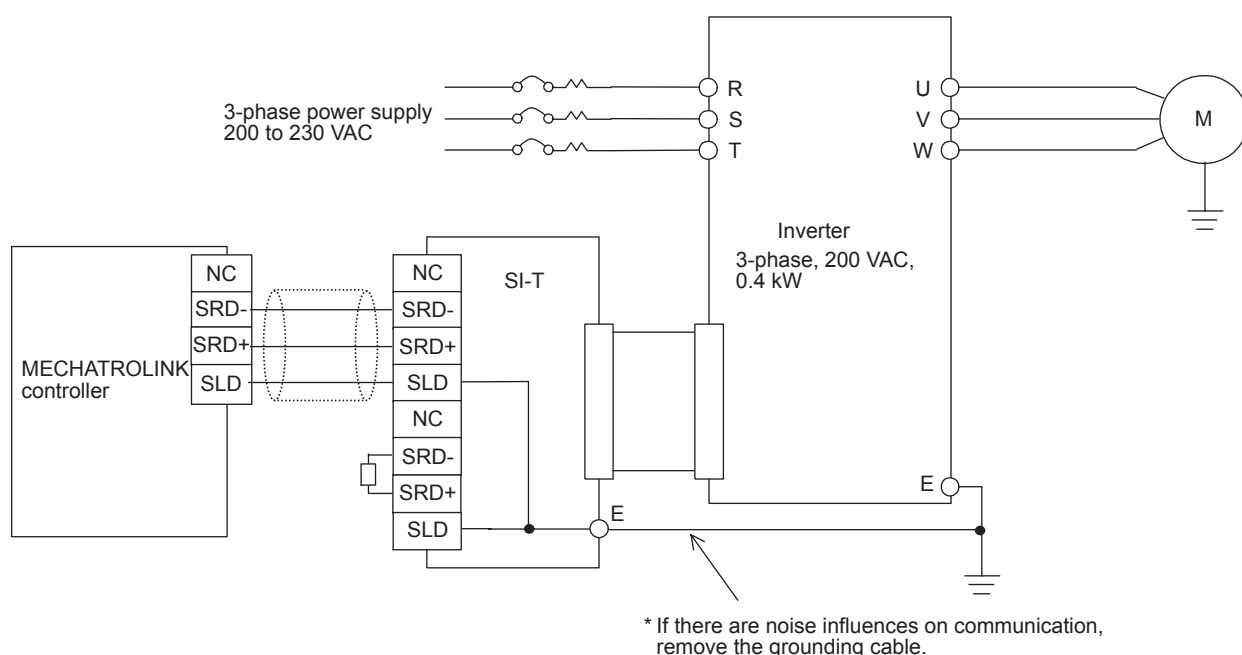
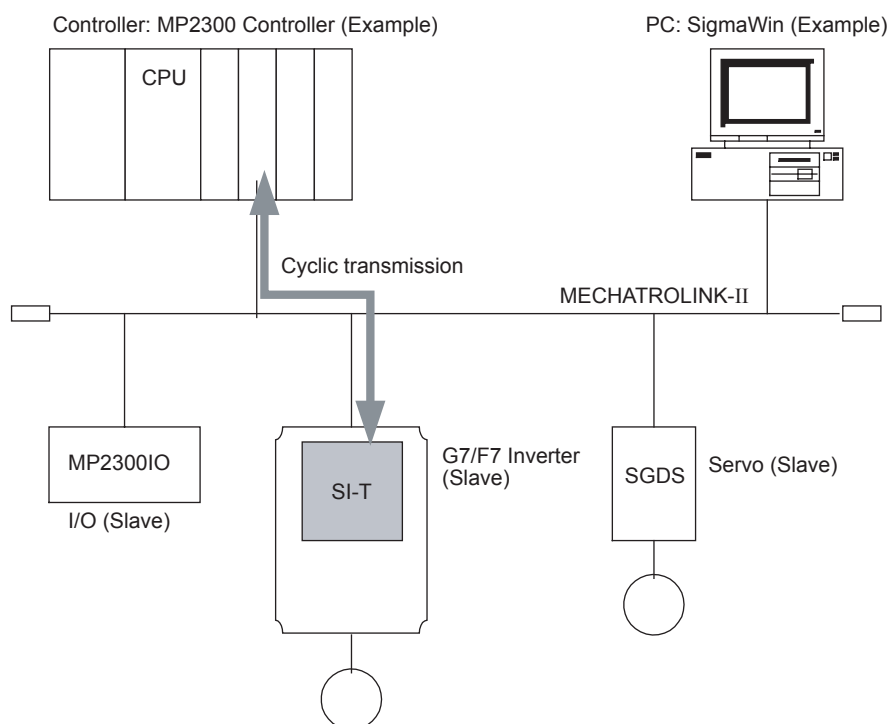

Fig. 2 Connection Diagram with Varispeed G7/F7 (3-phase, 200 VAC, 0.4 kW)

5 Transmission Interface

5.1 MECHATROLINK-II Cyclic Transmissions

As a MECHATROLINK-I/MECHATROLINK-II slave, the SI-T exchanges control data and I/O data with a control device, such as a controller. Communications with the controller are executed by sending response data timed to the reception of command data for the local station address from the controller in each transmission cycle. The formats for the command and response data follow the specifications for the MECHATROLINK Inverter commands.



5.2 Basic Format of Data Transfer

The basic format for transferring data is as follows.

The size of the header for a data link layer is fixed at two bytes.

By setting pin 2 on DIP switch S1, either 17 bytes (17-byte data transmission) or 32 bytes (32-byte data transmission) can be selected as the data size for the data link layer. If 32-byte data transmission is selected, only the first 29 bytes are used as application data.

* The first 30 bytes are used only when the INV_I/O sub-command is used.

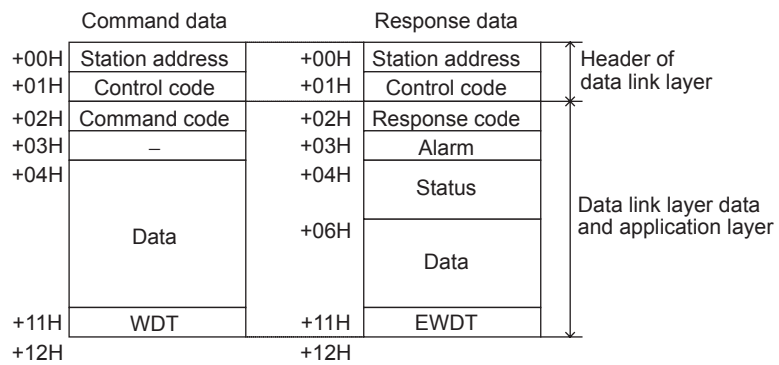

Basic format of data transfer (17-byte data transmission)

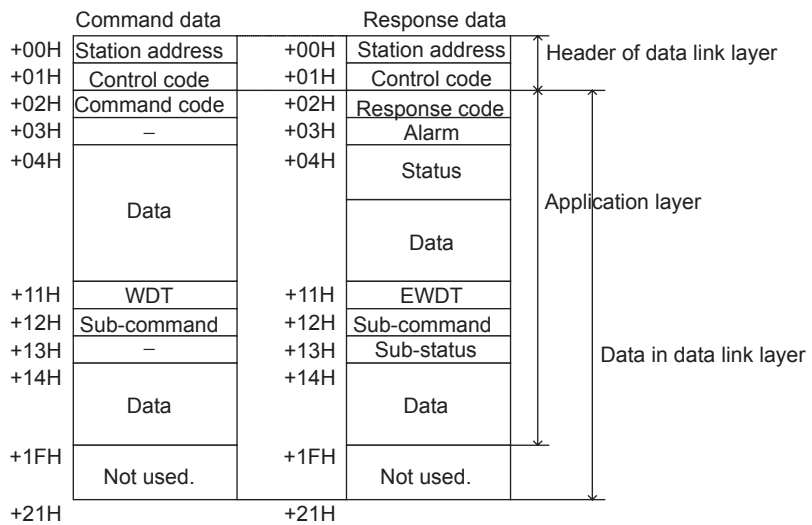

Basic format of data transfer (32-byte data transmission)

5.3 Communications Phases

The SI-T changes status as described here when a command code or fault is received from the master.

For details on MECHATROLINK communications phases, refer to the *High-speed Field Network MECHATROLINK System User's Manual* (SIE-S800-26.1).

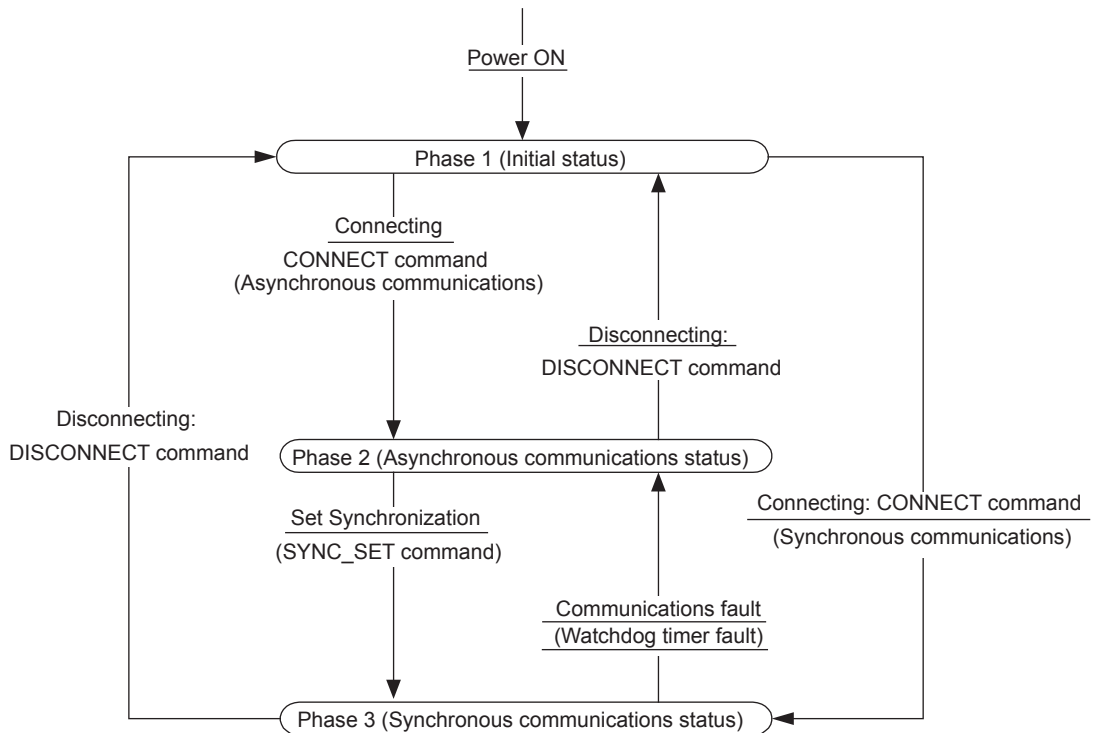

Phase 1: Initial status after power ON

Operation proceeds with a default transmission cycle of 2 ms. The transmission cycle is changed to the time indicated in the synchronous frame when a CONNECT command is received from the master. Then the phase moves to phase 2 or phase 3 after a response to the CONNECT command is returned.

Even if a transfer fault is detected in phase 1, no fault notification is provided.

Phase 2: Asynchronous communications

All SI-T commands can be used. Phase 2 starts to count the watchdog timer in the communications frame. The phase moves to phase 3 when a SYNC_SET command is received, and it moves to phase 1 when a DISCONNECT command is received.

Phase 3: Synchronous communications

Watchdog timer faults in the communications frame are detected. If the DISCONNECT command is received, the phase moves to phase 1. If a reception fault or a watchdog timer fault is detected, the phase moves to phase 2.

5.4 Application Layer Specifications

The data format for the application layer conforms to the MECHATROLINK-II link command specifications. The SI-T has the following main commands and sub-commands.

Table 1 Main Commands

Name	Function
NOP	No Operation
PRM_RD	Reads Parameters.
PRM_WR	Writes Parameters.
ID_RD	Reads ID numbers.
CONFIG	RAM Write ENTER_CODE and EEPROM Write ENTER_CODE
ALM_RD	Reads fault and alarm.
ALM_CLR	Clears fault and alarm.
CONNECT	Connect
DISCONNECT	Disconnect
INV_CTL	Controls Inverter Operation.
SYNC_SET	Starts Synchronous Communications.

Table 2 Sub-commands

Name	Function
NOP	No operation
PRM_RD	Reads Parameters.
PRM_WR	Writes Parameters.
ALM_RD	Reads fault and alarm.
INV_I/O	Controls Inverter I/O.

The main commands are used in both the 17-byte and 32-byte data transmissions for MECHATROLINK-II and with MECHATROLINK-I. The sub-commands can be used only when the 32-byte data transmission has been selected by means of pin 2 on DIP switch S1. If a conflict occurs between a request for a main command and a request for a sub-command, the request for the main command is processed. If either a main command or a sub-command is already being processed, the command being processed is given priority. If an INV_CTL main command and an INV_I/O sub-command conflict, the sub-command overwrites the main command.

For details on command formats, refer to *Chapter 7 MECHATROLINK-II Commands*.

6 Initial Setup

Before starting communications between the Inverter and the MECHATROLINK master, set the following constants as required.

Constant No.	Name	Description	Factory Setting
B1-02	Run command selection	0: Digital Operator 1: Control circuit terminal 2: MEMOBUS communications 3: Communications Option Card (Optional)	1
B1-01	Frequency reference selection	0: Digital Operator 1: Voltage reference 2: MEMOBUS communications 3: Communications Option Card (Optional) 4: Pulse train reference	1

* To run or stop through the MECHATROLINK communications, set 3 to B1-02. To set frequency, set 3 to B1-01.
For details, refer to the Varispeed G7/F7 Series Instruction Manual (TOE-S616-60.1, TOE-S616-55.1).

7 MECHATROLINK-II Commands

7.1 Main Commands

The format of the main commands are as follows.

■ No Operation (NOP)

Byte	Command	Response
1	NOP	NOP
2		ALARM
3		STATUS
4		
5		
6		
7		
8		
9		
10		
11		
12		
13		
14		
15		
16	WDT	RWDT

Only the ALARM and STATUS fields of the response data can be monitored.

This command can be used in all phases.

■ Read Parameter (PRM_RD)

Byte	Command	Response
1	PRM_RD	PRM_RD
2		ALARM
3		STATUS
4		
5	NO	NO
6		
7	SIZE	SIZE
8		PARAMETER
9		
10		
11		
12		
13		
14		
15		
16	WDT	RWDT

The PRM_RD command is used to read the Inverter's internal constants. For offline parameters, it reads the most recently updated setting values.

This command can be used in all phases.

Note: If the MECHATROLINK-II 32-byte data transmission is used, PRM_RD can be used only in a sub-command.

In the following cases, a warning (STATUS (WARNING) = 1) is generated and the command is ignored. If a warning is generated, the values that are read are undefined.

- While using the operator to change settings: Command alarm (A.95)
- If received as a main command in 32-byte data transmission: Command alarm (A.95)
- If a register number (NO) fault occurs: User constant setting alarm (A.94)
- If SIZE is an odd number or is not between 2 and 8: User constant setting alarm (A.94)

The register number (NO) is the same as the register number that is set and referenced in MEMOBUS transfers. Set the lower byte (LSB) before setting the upper byte (MSB).

The SI-T stores the data read for PARAMETER from lower byte (LSB) to upper byte (MSB).

For SIZE, set the number of bytes to be read as an even numbers. Eight bytes can be specified.

The values for the number (NO) and the size (SIZE) in the response are copies of the values in the command.

■ Write Parameter (PRM_WR)

Byte	Command	Response
1	PRM_WR	PRM_WR
2		ALARM
3		STATUS
4		
5		NO
6		
7	SIZE	SIZE
8	DATA	DATA
9		
10		
11		
12		
13		
14		
15		
16	WDT	RWDT

The PRM_WR command is used to write the Inverter's internal constants.

To save the setting value in the Inverter's EEPROM, set the CONFIG_MOD in the CONFIG command to 1. For details, refer to the section describing the CONFIG command.

Note: If the MECHATROLINK-II 32-byte data transmission is used, PRM_WR can be used only in a sub-command.

In the following cases, a warning is generated and the command is ignored.

- While using the Operator to change settings: Command alarm (A.95)
- If not in phase 2 or 3: Command alarm (A.95)
- During an undervoltage fault: Command alarm (A.95)
- If received as a main command in 32-byte data transmission: Command alarm (A.95)
- If a register number (NO) fault occurs: User constant setting alarm (A.94)
- If SIZE is an odd number or is not between 2 and 8: User constant setting alarm (A.94)
- Data upper/lower limit fault: User constant setting alarm (A.94)

The register number (NO) is the same as the register number that is set and referenced in MEMOBUS transfers.

Set the lower byte (LSB) before setting the upper byte (MSB).

Set the values for DATA from lower byte (LSB) to upper byte (MSB).

For SIZE, set the number of bytes to be written as an even number. Eight bytes can be specified.

The values for the NO, SIZE, and DATA in the response are copies of values in the command.

■ Read ID (ID_RD)

Byte	Command	Response
1	ID_RD	ID_RD
2		ALARM
3		STATUS
4		
5	DEVICE_CODE	DEVICE_CODE
6	OFFSET	OFFSET
7	SIZE	SIZE
8		ID
9		
10		
11		
12		
13		
14		
15		
16	WDT	RWDT

The ID_RD command is used to read the ID number.

The following table shows the applicable DEVICE_CODE.

Because of ID area limitations, no more than eight bytes can be read, so use the OFFSET and SIZE to specify the range.

The leading ID data that corresponds to the specified OFFSET and returned is shown in the following table.

Up to eight bytes can be used for SIZE.

This command can be used in all phases.

	DEVICE_CODE	ID content*6															
	OFFSET	00	01	02	03	04	05	06	07	08	09	0A	0B	0C	0D	0E	0F
Inverter Model	00H	C	I	M	R	-	G	7	*1	2	7	P	5				
Software Version	02H			S	1	2	3	4		S	5	6	7	8			
				*4	*4	*4	*4	*4		*5	*5	*5	*5	*5			

* 1. The A and U portions of special Inverter models G7A and G7U, as well as the portions showing the structure are represented by spaces.

* 2. Indicates the voltage class. 2: 200-VAC input; 4: 400-VAC input

* 3. Indicates the maximum applicable motor capacity. For 7.5 kW, 7P5 is shown.

* 4. Indicates the SI-T software code.

* 5. Indicates the Inverter software code.

* 6. Inverter models are expressed in ASCII, and end in 00H.

■ Write RAM ENTER_CODE/Write EEPROM ENTER_CODE (CONFIG)

Byte	Command	Response
1	CONFIG	CONFIG
2		ALARM
3		STATUS
4		
5		CONFIG_MOD
6		
7		
8		
9		
10		
11		
12		
13		
14		
15		
16	WDT	RWDT

The CONFIG command are used to enable the data for which constants have been written.

Error codes such as matching of constants cannot be checked by the responses to this command. They must be checked with the STATUS signal's OPE fault bit.

This command can be used in phases 2 and 3.

In the following cases, a warning is generated and the command is ignored.

- If not in phase 2 or 3: Command alarm (A.95)
- If CONFIG_MOD is not a set value: Data setting alarm (A.94)

The following values can be assigned to CONFIG_MOD.

CONFIG_MOD	Description
0	Write RAM ENTER_CODE The setting value is not saved in EEPROM.
1	The setting value is saved in EEPROM. Note: With the G7/F7, the maximum number of writes to non-volatile memory is 100, 000, so do not use the CONFIG command too frequently. If changing several constants, carry out the CONFIG command only after all the constants have been changed.

■ Read Alarm or Warning (ALM_RD)

Byte	Command	Response
1	ALM_RD	ALM_RD
2		ALARM
3		STATUS
4		
5		ALM_RD_MOD
6		ALM_DATA
7		
8		
9		
10		
11		
12		
13		
14		
15		
16	WDT	RWDT

The ALM_RD command is used to read the following information about the status of faults and alarms.

- Present fault and alarm status list
- Fault history (Alarms are not saved in the history.)
- Details of faults

In the following case, a warning is generated and the command is ignored.

- If ALM_RD_MOD is other than a set value: Data setting alarm (A.94)

The fault history is saved in EEPROM and is kept even when the control power is interrupted.

The following table shows the specifications for ALM_RD_MOD and ALM_DATA.

If the fault history (ALM_RD_MOD = 1) is selected, the fault code (1 byte) is entered in order of detection from ALM_DATA byte 6, and byte 6 is refreshed with the most recent fault code. If no fault occurred, 00H is displayed to indicate normal operations.

ALM_RD_MOD	ALM_DATA	Max. Processing Time	Constant No.
0	Present fault (byte 6), past fault (byte 7)	0.1 s	U2-01 and U2-02
1	Fault history (Alarms are not retained in the history.) 2 max. (bytes 6 and 7)*	0.1 s	U3-01 and U3-04

■ Clear Alarm or Warning (ALM_CLR)

Byte	Command	Response
1	ALM_CLR	ALM_CLR
2		ALARM
3		STATUS
4		
5	ALM_CLR_MOD	ALM_CLR_MOD
6		
7		
8		
9		
10		
11		
12		
13		
14		
15		
16	WDT	RWDT

The ALM_CLR command is used to clear the alarm and warning status.

This command changes the status of the slave station. It does not remove the cause of a fault. After the cause of the alarm or warning has been removed, this command is then used to clear the status of the alarm or warning.

In the following cases, a warning is generated and the command is ignored.

- If not in phase 2 or 3: Command alarm (A.95)
- If ALM_CLR_MOD is other than a set value: Data setting alarm (A.94)

ALM_CLR_MOD	Description
0	Clears the status of present faults and alarms.

Note: Inverter alarms cannot be reset while the Inverter RUN command is ON.

■ MECHATROLINK-II Connection (CONNECT)

Byte	Command	Response
1	CONNECT	CONNECT
2		ALARM
3		STATUS
4		
5		VER
6	COM_MOD	COM_MOD
7	COM_TIM	COM_TIM
8		
9		
10		
11		
12		
13		
14		
15		
16	WDT	RWDT

The CONNECT command is used to set the communications mode and establish a connection. After the connection is established, the phase moves to phase 2 or 3.

If a transfer fault is detected after moving to phase 2 or phase 3, notification is given of the fault. In phase 1, no notification is given even if a transfer fault is detected.

Set VER (version) to 21H (Ver. 2.1) for MECHATROLINK-II, and to 10H (Ver. 1.0) for MECHATROLINK-I. This setting must match the switch setting.

The communications mode is set by the COM_MOD. For details on the settings, refer to the following description.

- MECHATROLINK-II (VER: 21H)

Set the factor of the transmission cycle to COM_TIM (communications time) so that the setting range satisfies the following formulas.

When the transmission cycle is equal to the communications time (COM_TIM=1):

- 32-byte data transmission

$$1 \text{ [ms]} \leq \text{transmission cycle [ms]} \leq 8 \text{ [ms]}$$

If the transmission cycle is set to a fractional value, a warning (data setting alarm: A.94) is generated.

- 17-byte data transmission

$$0.5 \text{ [ms]} \leq \text{transmission cycle [ms]} \leq 8 \text{ [ms]}$$

If the transmission cycle is not set to a multiple of 0.5 ms, such as 0.75, a warning (data setting alarm: A.94) is generated.

When the transmission cycle is not equal to the communications time (1 < COM_TIM ≤ 32):

$$2 \text{ [ms]} \leq \text{transmission cycle [ms]} \times \text{COM_TIM} \leq 100 \text{ [ms]}$$

If the transmission cycle is less than 2 ms and is set to a fractional value, a warning (data setting alarm: A.94) is generated. If the communications cycle is set to a fractional value, a warning (data setting alarm: A.94) is generated.

- **MECHATROLINK-I (VER: 10H)**

Set the factor of the 2 ms transmission cycle to COM_TIM (communications time).

The setting range satisfies the following formulas.

$$2 \text{ [ms]} \leq \text{COM_TIM} \leq 64 \text{ [ms]}$$

COM_TIM is multiplied by a factor of 2.

In the following cases, a warning is generated and the command is ignored. Commands are also ignored in phase 2 (with no alarm).

- If COM_MOD is set out of range: Data setting alarm (A.94)
- If COM_TIM is set out of range: Data setting alarm (A.94)
- If SUBCMD is set to 1 in 17-byte data transmission: Data setting alarm (A.94)
- If SUBCMD is set to 1 for Ver. 1.0 (VER: 10H): Data setting alarm (A.94)
- If D6, D5, D4, D3, or D0 is set to 1: Data setting alarm (A.94)

For details on the transmission cycle, communications time, and communications phases, refer to the *High-speed Field Network MECHATROLINK System User's Manual* (SIE-S800-26.1).

COM_MOD

D7	D6	D5	D4	D3	D2	D1	D0
SUBCMD	0	0	0	DTMOD		SYNCMOD	0

Note: If D6, D5, D4, or D0 is set to 1, a warning will be generated (data setting alarm: A.94).

SUBCMD

0: Sub-command not used.

1: Sub-command used.

Note: With MECHATROLINK (VER: 10H), SUBCMD is fixed at 0.

DTMOD (Data Transfer Mode)

00: Single data transfer mode

10/11: Data setting alarm (A.94)

SYNCMOD (Synchronous/Asynchronous Communications)

0: Asynchronous communications. Move to phase 2.

1: Synchronous communications. Move to phase 3.

■ Disconnection (DISCONNECT)

Byte	Command	Response
1	DISCONNECT	DISCONNECT
2		ALARM
3		STATUS
4		
5		
6		
7		
8		
9		
10		
11		
12		
13		
14		
15		
16	WDT	RWDT

The DISCONNECT command is used to close the connection and move to phase 1.

After moving to phase 1, no check for transmission faults is executed.

This command can be used in phases 2 and 3.

If this command is received while in phase 2 or 3, the data for the control command to the Inverter is cleared to 0, and a fault reset command is carried out for the Inverter.

■ Inverter Control (INV_CTL)

Byte	Command	Response
1	INV_CTL	INV_CTL
2		ALARM
3	Operation signals	STATUS
4		
5	Speed reference	Output frequency
6		
7	Torque reference (torque limit)	Output current
8		
9	SEL REF1/2	SEL REF1/2
10	SEL MON1/2	SEL MON1/2
11	Reference selected by SEL REF1	Monitor selected by SEL MON1
12		
13	Reference selected by SEL REF2	Monitor selected by SEL MON2
14		
15		
16	WDT	RWDT

The INV_CTL command is used to set the Inverter's operation signals, speed references, and so on.

These bytes do not need to be set every scan. The settings are saved in the Inverter until the next data is received or until the power is turned OFF.

For details on operation signals, refer to the following table.

The speed reference unit can be selected with 01-03.

The torque reference is used for both positive and negative values, in units of 0.1%.

The output current can be set to units of 0.1 A or Inverter rated current/8192.

Table 3 Operation Signals

Bit	Description	Remarks
0	Forward operation	
1	Reverse operation	
2	INV multi-function terminal input 3	Default: External fault (EF3)
3	INV multi-function terminal input 4	Default: Fault reset
4	INV multi-function terminal input 5	Default: Multi-step speed reference 1
5	INV multi-function terminal input 6	Default: Multi-step speed reference 2
6	INV multi-function terminal input 7	Default: Jog command
7	INV multi-function terminal input 8 (G7)	Default: External baseblock
8	External fault (EFO)	
9	Fault reset ^{*1*2}	
A	INV multi-function terminal input 9 (G7)	Default: Multi-step speed reference 3
B	INV multi-function terminal input 10 (G7)	Default: Multi-step speed reference 4
C	INV multi-function terminal input 11 (G7)	Default: Accel/Decel time 1
D	INV multi-function terminal input 12 (G7)	Default: Emergency stop
E	Fault history trace clear	
F	External BB command	

* 1. Check that the faults has been successfully reset by confirming that the STATUS (RESET) bit has turned OFF.

* 2. Errors are not reported while the fault reset signal is ON.

Use the SEL REF1/2 command to select the contents of REF1 with bits 0 to 3 and to select the contents of REF2 with bits 4 to 7.

Use the SEL MON1/2 command to select the contents of MON1 with bits 0 to 3 and to select the contents of MON2 with bits 4 to 7.

The following tables show the selection ranges for SEL REF1/2 and SEL MON1/2.

Table 4 SEL REF1/2 Selection Range

REF1/2	Item	Remarks
0	Nothing selected	
1	Torque compensation 0.1 %	
2	INV analog terminal FM output	
3	INV analog terminal AM output	
4	INV terminal output: Bit 0: Terminals M1-M2 (Enabled when H2-01 = F) Bit 1: Terminal P1 (Enabled when H2-02 = F) Bit 2: Terminal P2 (Enabled when H2-03 = F)	
5 to F	Not used.	The SI-T ignores the written data.

Table 5 SEL MON1/2 Selection Range

MON1/2	Item	Remarks
0	Nothing selected.	
1	Output frequency According to o1-03.	
2	Torque reference (U1-09): 0.1 %	
3	Detected speed from PG counter.	
4	Frequency reference (U-01) According to o1-03.	
5	INV analog input A2 0.1 %.	
6	Main circuit current voltage: 1 V	
7	Inverter alarm	Refer to the Inverter alarm code list.
8	Inverter warning	Refer to the Inverter warning code list.
9	Not used.	
A	INV analog input A3 0.1 %.	
B	INV terminal DI input Bits 0 to 7: Terminals S1 to S8	
C	INV analog input S1: 0.1 %	
D	PG counter	
E, F	Not used.	Always 0.

In the following case, a warning is generated and the command is ignored.

- If not in phase 2 or 3: Command fault (A.95)

■ Start Synchronous Communications (SYNC_SET)

Byte	Command	Response
1	SYNC_SET	SYNC_SET
2		ALARM
3		STATUS
4		
5		
6		
7		
8		
9		
10		
11		
12		
13		
14		
15		
16	WDT	RWDT

The SYNC_SET command is used to request the start of synchronous communications. After this command is issued, synchronous communications are carried out. If communications become asynchronous due to any fault such as a communications fault, this command can be used to restore synchronous communications.

In the following case, a warning is generated and the command is ignored.

- If not in phase 2 or 3: Command fault (A.95)

7.2 Sub-commands

The format of sub-commands are as follows. Sub-commands can be used only with MECHATROLINK-II when the 32-byte data transmission has been selected by a switch.

■ No Operation (NOP)

Byte	Command	Response
17	NOP	NOP
18		SUBSTATUS
19		
20		
21		
22		
23		
24		
25		
26		
27		
28		
29		

This is the format of No Operation sub-command.

■ Read Parameter (PRM_RD)

Byte	Command	Response
17	PRM_RD	PRM_RD
18		SUBSTATUS
19	NO	NO
20		
21	SIZE	SIZE
22		PARAMETER
23		
24		
25		
26		
27		
28		
29		

The PRM_RD sub-command is used to read internal Inverter constants.

This sub-command functions in the same way as the PRM_RD main command.

In the following cases, a warning is generated and the command is ignored. If a warning is generated, the values that were read are undefined.

- While using the operator to change settings: Command alarm (A.95)
- If a register number (NO) fault occurs: User constant setting alarm (A.94)
- If SIZE is an odd number or is not between 2 and 8: User constant setting alarm (A.94)

■ Write Parameter (PRM_WR)

Byte	Command	Response
17	PRM_WR	PRM_WR
18		SUBSTATUS
19	NO	NO
20		
21	SIZE	SIZE
22	PARAMETER	PARAMETER
23		
24		
25		
26		
27		
28		
29		

The PRM_WR sub-command is used to write internal Inverter constants.

This sub-command functions in the same way as the PRM_WR main command.

In the following cases, a warning is generated and the command is ignored. If a warning is generated, the values that were read are undefined.

- While using the operator to change settings: Command alarm (A.95)
- If not in phase 2 or 3: Command fault (A.95)
- During an undervoltage error: Command alarm (A.95)
- If a register number (NO) fault occurs: User constant setting alarm (A.94)
- If SIZE is an odd number or is not between 2 and 8: User constant setting alarm (A.94)
- Data upper and lower limit fault: User constant setting alarm (A.94)

■ RAM Write ENTER_CODE/EEPROM Write ENTER_CODE (CONFIG)

Byte	Command	Response
17	CONFIG	CONFIG
18		SUBSTATUS
19	CONFIG_MOD	CONFIG_MOD
20		
21		
22		
23		
24		
25		
26		
27		
28		
29		

The CONFIG command is used to enable data for which constants have been written. This sub-command functions in the same way as the CONFIG main command.

In the following cases, a warning is generated and the command is ignored.

- If CONFIG_MOD is not set: Data setting value alarm (A.94)
- If not in phase 2 or 3: Command fault (A.95)

■ Read Alarm (ALM_RD)

Byte	Command	Response
17	ALM_RD	ALM_RD
18		SUBSTATUS
19	ALM_RD_MOD	ALM_RD_MOD
20		ALM_DATA
21		
22		
23		
24		
25		
26		
27		
28		
29		

The ALM_RD sub-command is used to read the fault and alarm status.

This sub-command functions in the same way as the ALM_RD main command.

In the following case, a warning is generated and the command is ignored.

- If ALM_RD_MOD is not set: Data setting alarm (A.94)

■ Inverter I/O Control (INV_I/O)

Byte	Sub-Command	Response
17	INV_I/O	INV_I/O
18		SUBSTATUS
19	SEL REF3/4	SEL REF3/4
20	SEL REF5/6	SEL REF5/6
21	SEL MON3/4	SEL MON3/4
22	SEL MON5/6	SEL MON5/6
23	Reference selected by SEL REF3.	Monitor selected by SEL MON3.
24		
25	Reference selected by SEL REF4.	Monitor selected by SEL MON4.
26		
27	Reference selected by SEL REF5.	Monitor selected by SEL MON5.
28		
29	Reference selected by SEL REF6.	Monitor selected by SEL MON6.
30		

The INV_I/O sub-command is used to select the type of output from the Inverter's external terminals and refers to the values from the Inverter's internal monitors.

These settings do not need to be set every scan. The settings are saved in the Inverter until the next data is received or until the power is turned OFF.

The output from the Inverter's external terminals is enabled when the multi-function input is set to not be used.

The SEL REF3/4 sub-command is used to select the contents of REF3 with bits 0 to 3, and select the contents of REF4 with bits 4 to 7.

The SEL REF5/6 sub-command is used to select the contents of REF5 with bits 0 to 3, and select the contents of REF6 with bits 4 to 7.

The selection range for SEL REF3 to 6 is the same as that for the SEL REF1/2 command in the INV_CTL main command.

The SEL MON3/4 sub-command is used to select the contents of MON3 with bits 0 to 3, and select the contents of MON4 with bits 4 to 7.

The SEL MON5/6 sub-command is used to select the contents of MON5 with bits 0 to 3, and select the contents of MON6 with bits 4 to 7.

The selection range for SEL MON3 to 6 is the same as that for the SEL MON1/2 command in the INV_CTL main command.

In the following cases, a warning is generated and the command is ignored.

- If not in phase 2 or 3: Command fault (A.95)

7.3 Status Details

This section describes the STATUS field for main commands and the SUBSTATUS field for sub-commands.

■ STATUS Field

Bit	Name	Description	Value	Setting
0	ALM	Alarm status	0	No alarm
			1	Alarm (fault)
1	WARNG	Warning status	0	No warning
			1	Warning
2	CMDRDY	Command ready	0	Busy
			1	Ready
3	BB OFF	Baseblock OFF (OFF when output voltage is being output from the Inverter or during baseblock.)	0	Baseblock ON
			1	Baseblock OFF
4	PON	Main power supply ON (OFF during undervoltage)	0	Main power supply OFF
			1	Main power supply ON
5	RUNX	Running	0	
			1	Running
6	0SP	Zero speed	0	
			1	Zero speed
7	REV	Reverse RUN	0	Forward RUN
			1	Reverse RUN
8	RESET	Fault reset signal input	0	
			1	Fault reset signal input
9	AGREE	Speed agreement	0	
			1	Speed agreement
A	INV_READY	Inverter ready	0	
			1	Inverter ready
B	OPE	OPE fault	0	
			1	OPE fault
C	UV_R	Recovery after power loss or recovery after momentary power loss	0	Recovery after power loss
			1	Recovery after momentary power loss
D	REMOTE	Local or Remote	0	Local
			1	Remote (Transfer)
E	-	Not used.	0	
			1	
F	-	Not used.	0	
			1	

* With the MEM_RD command, only the settings for the STATUS (CMDRDY) is valid. Other bits are not used.

■ SUBSTATUS Field

18th Byte

D7	D6	D5	D4	D3	D2	D1	D0
-	-	-	-	-	SUBCMDRDY	SUBWARNG	SUBALM

Bit	Name	Description	Value	Setting
D0	SUBALM	Sub-command alarm	0	No alarm
			1	Alarm
D1	SUBWARNG	Sub-command warning	0	No warning
			1	Warning
D2	SUBCMDRDY	Sub-command ready (Sub-command can be received.)	0	Busy
			1	Ready

Note: D3 to D7 are not used. A value of 0 is always returned.

8 Protective Operations

8.1 Fault Detection Processing

Faults can be detected by two methods: Inverter fault detection and SI-T fault detection.

The SI-T is notified of Inverter faults by the internal interface, and the SI-T sends the response data, ALARM or STATUS.

The SI-T notifies Inverter of SI-T faults by the internal interface, and the faults are simultaneously sent the response data, ALARM or STATUS.

The following four types of faults can be detected. The subsequent operation varies depending on the type of fault.

Fault Type		Description	Location
Alarm	Inverter alarm	Major fault that causes damage to the Inverter or machinery	Inverter
	Communications alarm	Interference related to MECHATROLINK-II communications	SI-T
Warning	Inverter warning	Illegal operation or minor fault not posing any immediate danger	Inverter
	Communications warning	MECHATROLINK-II communications fault warning	SI-T

Fault Type	SI-T Processing				Direction of Communications	Reset	
	MECHATROLINK Response			LED2 Status			Processing
	ALARM	STATUS					
	WARNG	ALM					
Inverter alarm	CODE	–	1	–	No special processing	←	Required
Communications alarm	CODE	–	1	Lit	Notification to Inverter	①→ ←②	Required
Inverter warning	CODE	1	–	–	No special processing	←	Required
Communications warning	CODE	1	–	–	No special processing	None	Not required

Note: The meanings of each symbol are as follows.

- : No change
- : Fault notification to Inverter
- ←: Fault notification from Inverter

When consecutive alarms occur, the SI-T provides notification of the most recent alarm with a MECHATROLINK response data. If warnings occur simultaneously, notification priority is given to the warning with the lowest warning code. If alarms and warnings are mixed together, the SI-T gives notification priority to alarms.

The following table shows the response data when consecutive alarms or warnings occurs.

Table 6 Response Data for Consecutive Alarms and/or Warnings

Fault Detection		MECHATROLINK-II Response Data Contents		
Previous Value	Most Recent Value	Alarm	STATUS	
			WARNG	ALM
Alarm	Alarm	Most recent alarm code	0	1
Alarm	Warning	Most recent alarm code	1	1
Warning	Alarm	Most recent alarm code	1	1
Warning	Warning	Warning with the smaller warning code	1	0

8.2 Alarm Processing

■ SI-T Communications Fault Detection

The following tables show the communications faults detected by the SI-T and the conditions in which they can be detected.

Table 7 Reception Failures in Each Phase

Communications Phase	Reception Failure		Transmission cycle
	First	Second (Consecutive)	Fault
Phase 1	–	–	–
Phase 2	96	E6	E6
Phase 3	96	E6	E6

Table 8 Alarm Code (MECHATROLINK-II Response ALARM Value)

ALARM	Description	Fault Type
96	MECHATROLINK-II communications fault warning	Communications warning
E5	MECHATROLINK-II WDT fault	Communications alarm
E6	MECHATROLINK-II communications fault	Communications alarm

Table 9 Fault Types

Fault	Description
Communications failure	Transmission LSI detected a data reception failure.
Transmission cycle fault	A timing fault of a synchronous frame in a transmission cycle was detected.
Watchdog timer fault	A WDT count fault in a synchronous frame was detected.

■ Other Faults

The following table shows other faults that can be detected by the SI-T.

If a warning occurs, operation will follow the previous command.

ALARM	Description	Fault Type	Operation when Fault Occurs
94	Data setting warning	Communications warning	Received commands are ignored.
95	Command warning	Communications warning	Received commands are ignored.
EC	WDC fault with Inverter	Communications alarm	Waits for power supply to be reset.
ED	Inverter access permission fault (Access not possible 10 consecutive times)	Communications alarm	Waits for power supply to be reset.
EE	Inverter monitor timer over (1 s elapsed)	Communications alarm	Waits for power supply to be reset. Received commands are ignored.*

* If the ERR indicator is not lit or flashing, any commands that are received will be ignored.

■ Inverter Fault Notification

If a fault is detected in the Inverter, the SI-T stores the alarm or warning code in the MECHATROLINK-II ALARM command and simultaneously turns ON the relevant bit in the STATUS field.

The following table shows the alarm codes for SI-T notification if a fault is detected in the Inverter.

Table 10 Inverter Alarm Codes

ALARM	Operator Display	Description	G7	F7
01H	PUF	Fuse blown	○	○
02H	UV1	Main circuit undervoltage	○	○
03H	UV2	Control power undervoltage	○	○
04H	UV3	Inrush prevention circuit fault	○	○
06H	GF	Ground fault	○	○
07H	OC	Overcurrent	○	○
08H	OV	Main circuit overvoltage	○	○
09H	OH	Cooling fin overheating	○	○
0AH	OH1	Inverter's cooling fan stopped	○	○
0BH	OL1	Motor overload	○	○
0CH	OL2	Inverter overload	○	○
0DH	OL3	Overtorque detected 1	○	○
0EH	OL4	Overtorque detected 2	○	○
0FH	RR	Internal braking transistor fault	○	○
10H	RH	Installed braking resistor overheating	○	○
11H	EF3	External fault 3	○	○
12H	EF4	External fault 4	○	○
13H	EF5	External fault 5	○	○
14H	EF6	External fault 6	○	○
15H	EF7	External fault 7	○	○
16H	EF8	External fault 8	○	○
18H	OS	Overspeed	○	○
19H	DEV	Excessive speed deviation	○	○
1AH	PGO	PG disconnection detected	○	○
1BH	PF	Main circuit voltage fault	○	○
1CH	LF	Output open phase	○	○
1DH	OH3	Motor overheating alarm	○	○
1EH	OPR	Digital operator connection fault	○	○
1FH	ERR	Operator error	○	○
20H	OH4	Motor overheating fault	○	○
21H	CE	MEMOBUS communications error	○	○
25H	CF	Control fault	○	○
26H	SVE	Zero-servo fault	○	○
27H	EF0	External fault input from communications option board	○	○
28H	FBL	PID feedback reference lost	○	○
29H	UL3	Undertorque detected 1	○	○

Table 10 Inverter Alarm Codes (cont'd)

ALARM	Operator Display	Description	G7	F7
2AH	UL4	Undertorque detected 2	○	○
2BH	OL7	High-slip braking OL	○	○
2CH	EF9	External fault 9	○	×
2DH	EF10	External fault 10	○	×
2EH	EF11	External fault 11	○	×
2FH	EF12	External fault 12	○	×
31H	VCF	Main circuit capacitor neutral point potential error	○	×
83H	CPF02	Baseblock circuit error	○	○
84H	CPF03	EEPROM Error	○	○
85H	CPF04	CPU internal A/D converter error	○	○
86H	CPF05	CPU external A/D converter error	○	○
87H	CPF06	Option board connection error	○	○
88H	CPF07	ASIC internal RAM fault	○	○
89H	CPF08	Watchdog timer fault	○	○
8AH	CPF09	CPU-ASIC mutual diagnosis fault	○	○
8BH	CPF10	ASIC version fault	○	○
91H	CPF20	Communications option board A/D converter error	○	○
92H	CPF21	Communications option board self diagnostic error	○	○
93H	CPF22	Communications option board model code error	○	○
94H	CPF23	Communications option board DPRAM error	○	○

Table 11 Inverter Warning Codes

ALARM	Operator Display	Description	G7	F7
01H	UV	Main circuit undervoltage	○	○
02H	OV	Main circuit overvoltage	○	○
03H	OH	Cooling fin overheating	○	○
04H	OH2	Inverter overheating pre-alarm	○	○
05H	OL3	Overtorque 1	○	○
06H	OL4	Overtorque 2	○	○
07H	EF	External fault	○	○
08H	BB	Receiving external baseblock command	○	○
09H	EF3	External fault 3	○	○
0AH	EF4	External fault 4	○	○
0BH	EF5	External fault 5	○	○
0CH	EF6	External fault 6	○	○
0DH	EF7	External fault 7	○	○
0EH	EF8	External fault 8	○	○
10H	OS	Overspeed	○	○
11H	DEV	Excessive speed deviation	○	○
12H	PGO	The PG is disconnected	○	○
13H	OPR	Digital operator connection fault	○	○
14H	CE	MEMOBUS communications error	○	○

Table 11 Inverter Warning Codes (cont'd)

ALARM	Operator Display	Description	G7	F7
17H	OL1	Motor overheat	○	○
18H	OL2	Inverter overheat	○	○
1AH	EF0	External fault detected for communications board other than SI-K2	○	○
1BH	RUNC	Reset during run command input error	○	○
1CH	FBL	PID feedback reference lost	○	○
1DH	CALL	Communications on standby	○	○
1EH	UL3	Undertorque 1	○	○
1FH	UL4	Undertorque 2	○	○
22H	OH3	Motor overheating 1	○	○
23H	EF9	External fault 9	○	×
24H	EF10	External fault 10	○	×
25H	EF11	External fault 11	○	×
26H	EF12	External fault 12	○	×

Table 12 Causes and Countermeasures of Main Faults Displayed on Varispeed G7/F7 Digital Operator

Display	Description	Cause	Countermeasures
BUS	Optional communications error	Communications are not established with the host controller.	Check the LED indicators. Check the communications cable wiring.
E5	SI-T WDT error	There is no continuity in the WDT for data sent by the host controller.	Execute DISCONNECT or ALM_CLR, and then use either the CONNECT or SYNC_SET command to move to phase 3.
EF0	External fault from option	An external fault is being input from the option card.	Turn OFF the faulty input.
CPF06	Optional Connection fault	The Inverter and communications option are not properly connected.	Turn OFF the power to the Inverter and check the connection between the Option Card and the Inverter. Then turn the power back ON. If the fault persists, replace the Option Card.
CPF21	Communications optional self-diagnostic fault	The communications option is faulty.	Turn OFF and back ON the power to the Inverter. If the fault persists, replace the Option Card.
CPF22	Communications optional model code fault		
CPF23	Communications optional mutual-diagnostic fault		

For information on the causes and countermeasures for other faults, refer to the *Varispeed G7/F7 Series Instruction Manual* (Manual NO.: TOE-S616-60.1/TOE-S616-55.1).

9 Specifications

Item	Requirements
Baud rate	4 Mbps or 10 Mbps ^{*1}
Access mode	Start-stop synchronization, master/slave method
Transmission cycle	500 µs to 8 ms ^{*2}
Maximum transmission distance	50 m ^{*5}
Data length	17-byte data transmission or 32-byte data transmission ^{*3}
Maximum number of slaves	30 ^{*4 *5}
Operating Power Supply	4.75 VDC to 5.25 VDC (supplied from Inverter)
Ambient Temperature	-10°C to 45°C
Humidity	95% max. (with no condensation)
Storage Temperature	-20°C to 60°C
Location	Indoors (free from corrosive gases or dust)
Elevation	1000 m max.

- * 1. The baud rate is 4 Mbps for MECHATROLINK-I, and 10 Mbps for MECHATROLINK-II.
- * 2. For MECHATROLINK-I, a cycle is 2 ms. For MECHATROLINK-II, a cycle is 1 ms to 8 ms for a 32-byte data transmission, and 500 µs to 8 ms for a 17-byte data transmission.
- * 3. For MECHATROLINK-I, only a 17-byte data transmission can be selected.
- * 4. The maximum number of connectable stations changes depending on the types and settings of the host controller, baud rate, or communications cycle. For details, refer to the manuals of your controller.
 Communications cycle: Integral multiple of transmission cycles (depending on the host controller settings).
 Example: If the host controller is an MP2300
 - For MECHATROLINK-II (32-byte transmission, 2-ms communications cycle):
21 stations max. (21 slaves can be set, but then the maximum number of connectable Inverters will be 16.)
 - For MECHATROLINK-II (32-byte transmission, 1-ms communications cycle):
9 stations max.
 - For MECHATROLINK-II (17-byte transmission, 1-ms communications cycle):
15 stations max.
 - For MECHATROLINK-I: 14 stations max.
- * 5. At the maximum transmission distance of 50 m, the maximum number of slaves is 15.

Revision History

The revision dates and numbers of the revised manuals are given on the bottom of the back cover.

MANUAL NO. SIBP C730600 08A

© Printed in Japan December 2004 04-12
└─ Date of printing └─ Date of original publication

Date of Printing	Rev. No.	Section	Revised Content
December 2004	–		First edition

Varispeed G7/F7 OPTION CARD MECHATROLINK COMMUNICATIONS INTERFACE CARD USER'S MANUAL

IRUMA BUSINESS CENTER

480, Kamifujisawa, Iruma, Saitama 358-8555, Japan
Phone 81-4-2962-5696 Fax 81-4-2962-6138

YASKAWA ELECTRIC AMERICA, INC.

2121 Norman Drive South, Waukegan, IL 60085, U.S.A.
Phone 1-847-887-7000 Fax 1-847-887-7370

MOTOMAN INC. HEADQUARTERS

805 Liberty Lane West Carrollton, OH 45449, U.S.A.
Phone 1-937-847-6200 Fax 1-937-847-6277

YASKAWA ELÉTRICO DO BRASIL COMÉRCIO LTD.A.

Avenida Fagundes Filho, 620 Bairro Saude-Sao Paulo-SP, Brazil CEP: 04304-000
Phone 55-11-5071-2552 Fax 55-11-5581-8795

YASKAWA ELECTRIC EUROPE GmbH

Am Kronberger Hang 2, 65824 Schwalbach, Germany
Phone 49-6196-569-300 Fax 49-6196-569-312

Motoman Robotics Europe AB

Box 504 S38525 Torsås, Sweden
Phone 46-486-48800 Fax 46-486-41410

Motoman Robotec GmbH

Kammerfeldstraße 1, 85391 Allershausen, Germany
Phone 49-8166-90-100 Fax 49-8166-90-103

YASKAWA ELECTRIC UK LTD.

1 Hunt Hill Orchardton Woods Cumbernauld, G68 9LF, United Kingdom
Phone 44-1236-735000 Fax 44-1236-458182

YASKAWA ELECTRIC KOREA CORPORATION

7F, Doore Bldg. 24, Yeoido-dong, Youngdungpo-Ku, Seoul 150-877, Korea
Phone 82-2-784-7844 Fax 82-2-784-8495

YASKAWA ELECTRIC (SINGAPORE) PTE. LTD.

151 Lorong Chuan, #04-01, New Tech Park Singapore 556741, Singapore
Phone 65-6282-3003 Fax 65-6289-3003

YASKAWA ELECTRIC (SHANGHAI) CO., LTD.

No.18 Xizang Zhong Road. Room 1805, Harbour Ring Plaza Shanghai 20000, China
Phone 86-21-5385-2200 Fax 86-21-5385-3299

YATEC ENGINEERING CORPORATION

4F., No.49 Wu Kong 6 Rd, Wu-Ku Industrial Park, Taipei, Taiwan
Phone 886-2-2298-3676 Fax 886-2-2298-3677

YASKAWA ELECTRIC (HK) COMPANY LIMITED

Rm. 2909-10, Hong Kong Plaza, 186-191 Connaught Road West, Hong Kong
Phone 852-2803-2385 Fax 852-2547-5773

BEIJING OFFICE

Room No. 301 Office Building of Beijing International Club, 21
Jianguomenwai Avenue, Beijing 100020, China
Phone 86-10-6532-1850 Fax 86-10-6532-1851

TAIPEI OFFICE

9F, 16, Nanking E. Rd., Sec. 3, Taipei, Taiwan
Phone 886-2-2502-5003 Fax 886-2-2505-1280

SHANGHAI YASKAWA-TONGJI M & E CO., LTD.

27 Hui He Road Shanghai China 200437
Phone 86-21-6553-6060 Fax 86-21-5588-1190

BEIJING YASKAWA BEIKE AUTOMATION ENGINEERING CO., LTD.

30 Xue Yuan Road, Haidian, Beijing P.R. China Post Code: 100083
Phone 86-10-6233-2782 Fax 86-10-6232-1536

SHOUGANG MOTOMAN ROBOT CO., LTD.

7, Yongchang-North Street, Beijing Economic Technological Investment & Development Area,
Beijing 100076, P.R. China
Phone 86-10-6788-0551 Fax 86-10-6788-2878



YASKAWA ELECTRIC CORPORATION

YASKAWA

In the event that the end user of this product is to be the military and said product is to be employed in any weapons systems or the manufacture thereof, the export will fall under the relevant regulations as stipulated in the Foreign Exchange and Foreign Trade Regulations. Therefore, be sure to follow all procedures and submit all relevant documentation according to any and all rules, regulations and laws that may apply.

Specifications are subject to change without notice for ongoing product modifications and improvements.

© 2004 YASKAWA ELECTRIC CORPORATION. All rights reserved.

MANUAL NO. SIBP C730600 08A

Printed in Japan December 2004 04-12

04-8⑥ 04-71014