

# NT-DRT21

## DeviceNet (CompoBus/D) Interface Unit

# OPERATION MANUAL



# OMRON

**NT-DRT21**

**DeviceNet (CompoBus/D)  
Interface Unit**

**Operation Manual**

*Produced August 2000*





## Notice:

OMRON products are manufactured for use according to proper procedures by a qualified operator and only for the purposes described in this manual.

The following conventions are used to indicate and classify precautions in this manual. Always heed the information provided with them. Failure to heed precautions can result in injury to people or damage to property.

 **DANGER** Indicates an imminently hazardous situation which, if not avoided, will result in death or serious injury.

 **WARNING** Indicates a potentially hazardous situation which, if not avoided, could result in death or serious injury.

 **Caution** Indicates a potentially hazardous situation which, if not avoided, may result in minor or moderate injury, or property damage.

## OMRON Product References

All OMRON products are capitalized in this manual. The word “Unit” is also capitalized when it refers to an OMRON product, regardless of whether or not it appears in the proper name of the product.

The abbreviation “Ch,” which appears in some displays and on some OMRON products, often means “word” and is abbreviated “Wd” in documentation in this sense.

The abbreviation “PC” means Programmable Controller and is not used as an abbreviation for anything else.

The abbreviation “PT” refers to OMRON NT-series and NTH-series Programmable Terminals. The DeviceNet (CompoBus/D) Interface Unit is used with NT31, NT31C, NT631, and NT631C PTs.

“CS1 Series” refers to CS1H and CS1G PCs and related products.

“C Series” refers to C200H, C1000H(F), C2000H, C200HS, CPM1, and CQM1 PCs and related products.

“CVM1/CV Series” refers to CV500, CV1000, CV2000, and CVM1 PCs and related products.

“CPU Unit” refers to OMRON CS1-series, C200HX/HG/HE(-Z), C-series, and CVM1/CV-series CPU Units.

“Support Tool” refers to the following NT-series Support Tools for Windows (Ver. 3.2 or later):

- Ver. 3.2: NT-ZJ3AT1-EV3/NT-ZJCAT1-EV3
- Ver. 4.1: NT-ZJCAT1-EV4

Only the above Support Tools can be used to create screen data for PTs to which the DeviceNet (CompoBus/D) Interface Unit is mounted.

The term “host” refers to the control device (e.g., PC or computer) that controls the PT.

## Visual Aids

The following headings appear in the left column of the manual to help you locate different types of information.

**Note** Indicates information of particular interest for efficient and convenient operation of the product.

**1, 2, 3...** 1. Indicates lists of one sort or another, such as procedures, checklists, etc.

© **OMRON, 2000**

All rights reserved. No part of this publication may be reproduced, stored in a retrieval system, or transmitted, in any form, or by any means, mechanical, electronic, photocopying, recording, or otherwise, without the prior written permission of OMRON.

No patent liability is assumed with respect to the use of the information contained herein. Moreover, because OMRON is constantly striving to improve its high-quality products, the information contained in this manual is subject to change without notice. Every precaution has been taken in the preparation of this manual. Nevertheless, OMRON assumes no responsibility for errors or omissions. Neither is any liability assumed for damages resulting from the use of the information contained in this publication.

# TABLE OF CONTENTS

<b>PRECAUTIONS</b> .....	<b>xi</b>
1 Intended Audience .....	xii
2 General Precautions .....	xii
3 Safety Precautions .....	xii
4 Operating Environment Precautions .....	xiii
5 Application Precautions .....	xiii
6 Conformance to EC Directives .....	xvii
<b>SECTION 1</b>	
<b>Introduction</b> .....	<b>1</b>
1-1 Features of the DeviceNet Interface Unit .....	2
1-2 DeviceNet Functions .....	3
1-3 System Configuration .....	7
1-4 Outline of Configurator .....	9
1-5 Functions of the DeviceNet (CompoBus/D) Interface Unit .....	10
<b>SECTION 2</b>	
<b>Operating Procedures</b> .....	<b>15</b>
2-1 Operating Procedures Flowchart .....	16
2-2 Simple System Configuration .....	20
<b>SECTION 3</b>	
<b>Network Design</b> .....	<b>21</b>
3-1 Network Configuration .....	22
3-2 Limitations on the Network Configuration .....	24
3-3 Sharing the Communications Power Supply .....	27
3-4 Grounding the Network .....	37
3-5 Noise Precautions .....	38
3-6 Correcting Faulty Operation Caused by Noise .....	40
3-7 Sharing the Same Power Supply .....	40
<b>SECTION 4</b>	
<b>Installation and Network Connection</b> .....	<b>43</b>
4-1 Components and Their Functions .....	44
4-2 Mounting the Unit on the PT .....	45
4-3 Connecting to the DeviceNet Network .....	45
<b>SECTION 5</b>	
<b>PT Settings and Operations</b> .....	<b>51</b>
5-1 Installing the System Program .....	52
5-2 Structure of the System Menu .....	56
5-3 Initializing DeviceNet (CompoBus/D) Memory Switches .....	57
5-4 Serial Port A Settings .....	59
5-5 DeviceNet (CompoBus/D) Memory Switch Settings .....	61
5-6 Checking the PT Settings .....	64
5-7 Checking Communications with the PT .....	66
5-8 Checking the System Program Version .....	67
<b>SECTION 6</b>	
<b>Remote I/O Communications</b> .....	<b>69</b>
6-1 Overview of Remote I/O Communications .....	70
6-2 Settings with the NT-series Support Tool .....	72
6-3 Allocating PT Memory to the Host (Master) .....	74
6-4 Allocating PT Data to PT Memory .....	81

# TABLE OF CONTENTS

## SECTION 7

### **Message Communications . . . . . 83**

7-1 Overview of Message Communications . . . . .	84
7-2 Using Message Communications . . . . .	85
7-3 Explicit Messages . . . . .	99
7-4 Sample Program . . . . .	103

## SECTION 8

### **Error Processing . . . . . 107**

8-1 Error Screens Specific to the DeviceNet Interface Unit . . . . .	108
8-2 Troubleshooting with the LED Indicators . . . . .	109

## Appendices

A Device Protocol . . . . .	111
B Comparison of System Program Functions . . . . .	117
C Standard Models . . . . .	119

### **Index . . . . . 123**

### **Revision History . . . . . 125**

## About this Manual:

This manual describes the installation and operation of the NT-DRT21 DeviceNet (CompoBus/D) Interface Unit and includes the sections described below. The DeviceNet Interface Unit can be used with the NT31, NT31C, NT631, and NT631C Programmable Terminals (PTs).

Please read this manual carefully and be sure you understand the information provided before attempting to install and operate a DeviceNet Interface Unit.

**Section 1** describes the main features and basic functions of the DeviceNet (CompoBus/D) system and the DeviceNet (CompoBus/D) Interface Unit.

**Section 2** shows a simple system configuration example and basic procedures up to using the PT connected to the DeviceNet Interface Unit.

**Section 3** provides information required when designing a network, such as precautions regarding the configuration of the DeviceNet network to which the CompoBus/D Interface Unit connects.

**Section 4** explains how to mount the DeviceNet Interface Unit on the PT and connect the Unit to the DeviceNet network.

**Section 5** explains the PT settings and operations required to use the DeviceNet Interface Unit.

**Section 6** shows how to use remote I/O communications with the DeviceNet Interface Unit and how to use the PT when using remote I/O communications.

**Section 7** explains how to use message communications with a DeviceNet Interface Unit and how to use the PT when message communications are being used.

**Section 8** explains how to troubleshoot errors that may occur when using the DeviceNet Interface Unit. Refer to the CompoBus/D (DeviceNet) User's Manual and the PT's User's Manual for more details.

The **Appendices** provide relevant DeviceNet protocol specifications, comparisons between different system program versions, and a list of related products.

## Copyrights and Trademarks

DeviceNet is a registered trademark of the Open DeviceNet Vendor Association.

The copyright to the software installed in the DeviceNet (CompoBus/D) Master Unit belongs to Woodhead Industries Inc.

Microsoft® and Windows® are either registered trademarks or trademarks of Microsoft Corporation in the United States and/or other countries.

Other product names and company names that appear in this manual are trademarks or registered trademarks of their respective companies.



**WARNING** Failure to read and understand the information provided in this manual may result in personal injury or death, damage to the product, or product failure. Please read each section in its entirety and be sure you understand the information provided in the section and related sections before attempting any of the procedures or operations given.



## Related Manuals

The following manuals are related to DeviceNet or PT applications. Refer to them as required. Catalog suffixes showing the version and production site have been omitted. Be sure you have the correct version for your region.

Application	Contents	Manual name	Catalog number
Connecting or programming for a PT connected to DeviceNet	Connecting a PT with a DeviceNet Interface Unit to a DeviceNet network. Communications between the PT and DeviceNet network. Installing the system program for the DeviceNet Interface Unit into the PT. PT system menus for using the DeviceNet Interface Unit.	DeviceNet (CompoBus/D) Interface Unit Operation Manual (This manual)	V066
Operating a PT	Descriptions of PT function and operation. Refer to the <i>Setup Manual</i> for your PT for settings, peripheral device connections, and other hardware information. Refer to the <i>Reference Manual</i> for PT functions, details on screen elements, and host communications.  A PT with a DeviceNet Interface Unit has functionality equivalent to a PT with a model number ending in "V1" (system program version 2.1). These three manuals describe the functions of PTs with model numbers ending in "V2." Refer to <i>Appendix B Comparison of System Program Functions</i> for details on differences before using any functions.	NT31/NT31C Setup Manual	V062
		NT631/NT631C Setup Manual	V063
		NT31/NT631 Reference Manual	V064
Creating or transferring screen data or installing system programs	Descriptions of methods for creating and transferring screens. (The Support Tool is used to create and transfer screens for the PT to which the DeviceNet Interface Unit is mounted. You must use version 3.2 or later of the Support Tool.)	NT-series Support Tool for Windows Operation Manual	V061
Constructing a DeviceNet network	Information on OMRON DeviceNet products and network configuration.  Refer to the <i>DeviceNet (CompoBus/D) Operation Manual</i> for overall network details and using the DeviceNet Master Unit and refer to the <i>DeviceNet (CompoBus/D) Configurator Operation Manual</i> for detailed control and setting methods.	DeviceNet (CompoBus/D) Operation Manual	W267
		DeviceNet (CompoBus/D) Slave Operation Manual	W347
		DeviceNet (CompoBus/D) MULTIPLE I/O TERMINAL Operation Manual	W348
		DeviceNet (CompoBus/D) Configurator Operation Manual	W328

# PRECAUTIONS

This section provides general precautions for using the CS1-series Programmable Controllers (PCs) and related devices.

**The information contained in this section is important for the safe and reliable application of Programmable Controllers. You must read this section and understand the information contained before attempting to set up or operate a PC system.**

1 Intended Audience .....	xii
2 General Precautions .....	xii
3 Safety Precautions .....	xii
4 Operating Environment Precautions .....	xiii
5 Application Precautions .....	xiii
6 Conformance to EC Directives .....	xvii
6-1 Applicable Directives .....	xvii
6-2 Concepts .....	xvii
6-3 Conformance to EC Directives .....	xvii
6-4 Relay Output Noise Reduction Methods .....	xvii

## 1 Intended Audience

This manual is intended for the following personnel, who must also have knowledge of electrical systems (an electrical engineer or the equivalent).

- Personnel in charge of installing FA systems.
- Personnel in charge of designing FA systems.
- Personnel in charge of managing FA systems and facilities.

## 2 General Precautions

The user must operate the product according to the performance specifications described in the operation manuals.

Before using the product under conditions which are not described in the manual or applying the product to nuclear control systems, railroad systems, aviation systems, vehicles, combustion systems, medical equipment, amusement machines, safety equipment, and other systems, machines, and equipment that may have a serious influence on lives and property if used improperly, consult your OMRON representative.

Make sure that the ratings and performance characteristics of the product are sufficient for the systems, machines, and equipment, and be sure to provide the systems, machines, and equipment with double safety mechanisms.

This manual provides information for using the DeviceNet (CompoBus/D) I/F Unit. Be sure to read this manual before attempting to use the Unit and keep this manual close at hand for reference during operation.

 **WARNING** It is extremely important that a PC and all PC Units be used for the specified purpose and under the specified conditions, especially in applications that can directly or indirectly affect human life. You must consult with your OMRON representative before applying a PC System to the above-mentioned applications.





## 3 Safety Precautions

 **WARNING** The CPU Unit refreshes I/O even when the program is stopped (i.e., even in PROGRAM mode). Confirm safety thoroughly in advance before changing the status of any part of memory allocated to I/O Units, Special I/O Units, or CPU Bus Units. Any changes to the data allocated to any Unit may result in unexpected operation of the loads connected to the Unit. Any of the following operation may result in changes to memory status.



- Transferring I/O memory data to the CPU Unit from a Programming Device.
- Changing present values in memory from a Programming Device.
- Force-setting/-resetting bits from a Programming Device.
- Transferring I/O memory files from a Memory Card or EM file memory to the CPU Unit.
- Transferring I/O memory from a host computer or from another PC on a network.

 **WARNING** Do not attempt to take any Unit apart while the power is being supplied. Doing so may result in electric shock.

 **WARNING** Do not touch any of the terminals or terminal blocks while the power is being supplied. Doing so may result in electric shock.

-  **WARNING** Do not attempt to disassemble, repair, or modify any Units. Any attempt to do so may result in malfunction, fire, or electric shock.
-  **WARNING** Do not touch the Power Supply Unit while power is being supplied or immediately after power has been turned OFF. Doing so may result in electric shock.
-  **Caution** Execute online edit only after confirming that no adverse effects will be caused by extending the cycle time. Otherwise, the input signals may not be readable.
-  **Caution** Confirm safety at the destination node before transferring a program to another node or changing contents of the I/O memory area. Doing either of these without confirming safety may result in injury.
-  **Caution** Tighten the screws on the terminal block of the AC Power Supply Unit to the torque specified in the operation manual. The loose screws may result in burning or malfunction.

## 4 Operating Environment Precautions

-  **Caution** Do not operate the control system in the following locations:
- Locations subject to direct sunlight.
  - Locations subject to temperatures or humidity outside the range specified in the specifications.
  - Locations subject to condensation as the result of severe changes in temperature.
  - Locations subject to corrosive or flammable gases.
  - Locations subject to dust (especially iron dust) or salts.
  - Locations subject to exposure to water, oil, or chemicals.
  - Locations subject to shock or vibration.
-  **Caution** Take appropriate and sufficient countermeasures when installing systems in the following locations:
- Locations subject to static electricity or other forms of noise.
  - Locations subject to strong electromagnetic fields.
  - Locations subject to possible exposure to radioactivity.
  - Locations close to power supplies.
-  **Caution** The operating environment of the PC System can have a large effect on the longevity and reliability of the system. Improper operating environments can lead to malfunction, failure, and other unforeseeable problems with the PC System. Be sure that the operating environment is within the specified conditions at installation and remains within the specified conditions during the life of the system.

## 5 Application Precautions

Observe the following precautions when using the PC System.

- You must use the CX-Programmer (programming software that runs on Windows) if you need to program more than one task. A Programming Console can be used to program only one cyclic task plus interrupt tasks. A Programming Console can, however, be used to edit multitask programs originally created with the CX-Programmer.

- There are restrictions in the areas and addresses that can be accessed in I/O memory of the CS1-series CPU Units when using the C200H Special I/O Units in combination with the following functions.
  - There are restrictions in data transfer with the CPU Unit when programming transfers inside an ASCII Unit using the PC READ, PC WRITE, and similar commands.
  - There are restrictions in data transfer with the CPU Unit for allocated bits and DM area specifications (areas and addresses for source and destination specifications).
  - The DeviceNet (CompoBus/D) output area for a DeviceNet Master Unit (CIO 0050 to CIO 0099) overlaps with the I/O bit area (CIO 0000 to CIO 0319). Do not use automatic allocations for I/O in any system where allocations to the DeviceNet system will overlap with allocations to I/O Units. Instead, use a Programming Device or the CX-Programmer to manually allocate I/O for the DeviceNet devices, being sure that the same words and bits are not allocated more than once, and transfer the resulting I/O table to the CPU Unit. If DeviceNet communications are attempted when the same bits are allocated to both DeviceNet devices and I/O Units (which can occur even if automatic allocation is used), the DeviceNet devices and I/O Units may both exhibit faulty operation.
  - Special bits and flags for PC Link Units (CIO 0247 to CIO 0250) overlap with the I/O bit area (CIO 0000 to CIO 0319). Do not use automatic allocations for I/O in any system where allocations to the I/O Units will overlap with allocations to I/O Units. Instead, use a Programming Device or the CX-Programmer to manually allocate I/O to I/O Units, being sure that the the special bits and flags for PC Link Units are not used, and transfer the resulting I/O table to the CPU Unit. If operation is attempted when the special bits and flags for PC Link Units are also allocated to I/O Units (which can occur even if automatic allocation is used), the PC Link Units and I/O Units may both exhibit faulty operation.

 **WARNING** Always heed these precautions. Failure to abide by the following precautions could lead to serious or possibly fatal injury.

- Always connect to a ground of 100  $\Omega$  or less when installing the Units. Not connecting to a ground of 100  $\Omega$  or less may result in electric shock.
- A ground of 100  $\Omega$  or less must be installed when shorting the GR and LG terminals on the Power Supply Unit.
- Always turn OFF the power supply to the PC before attempting any of the following. Not turning OFF the power supply may result in malfunction or electric shock.
  - Mounting or dismounting I/O Units, CPU Units, Inner Boards, or any other Units.
  - Assembling the Units.
  - Setting DIP switches or rotary switches.
  - Connecting cables or wiring the system.
  - Connecting or disconnecting the connectors.

 **Caution** Failure to abide by the following precautions could lead to faulty operation of the PC or the system, or could damage the PC or PC Units. Always heed these precautions.

- When using a CPU Unit for the first time, install the CS1W-BAT1 Battery provided with the Unit and clear all memory areas from a Programming Device before starting to program.

- When using the internal clock, turn ON power after installing the battery and set the clock from a Programming Device or using the DATE(735) instruction. The clock will not start until the time has been set.
- When creating an AUTOEXEC.IOM file from a Programming Device (a Programming Console or the CX-Programmer) to automatically transfer data at startup, set the first write address to D20000 and be sure that the size of data written does not exceed the size of the DM Area. When the data file is read from the Memory Card at startup, data will be written in the CPU Unit starting at D20000 even if another address was set when the AUTOEXEC.IOM file was created. Also, if the DM Area is exceeded (which is possible when the CX-Programmer is used), the remaining data will be written to the EM Area.
- Always turn ON power to the PC before turning ON power to the control system. If the PC power supply is turned ON after the control power supply, temporary errors may result in control system signals because the output terminals on DC Output Units and other Units will momentarily turn ON when power is turned ON to the PC.
- Fail-safe measures must be taken by the customer to ensure safety in the event that outputs from Output Units remain ON as a result of internal circuit failures, which can occur in relays, transistors, and other elements.
- Fail-safe measures must be taken by the customer to ensure safety in the event of incorrect, missing, or abnormal signals caused by broken signal lines, momentary power interruptions, or other causes.
- Interlock circuits, limit circuits, and similar safety measures in external circuits (i.e., not in the Programmable Controller) must be provided by the customer.
- Do not turn OFF the power supply to the PC when data is being transferred. In particular, do not turn OFF the power supply when reading or writing a Memory Card. Also, do not remove the Memory Card when the BUSY indicator is lit. To remove a Memory Card, first press the memory card power supply switch and then wait for the BUSY indicator to go out before removing the Memory Card.
- If the I/O Hold Bit is turned ON, the outputs from the PC will not be turned OFF and will maintain their previous status when the PC is switched from RUN or MONITOR mode to PROGRAM mode. Make sure that the external loads will not produce dangerous conditions when this occurs. (When operation stops for a fatal error, including those produced with the FALS(007) instruction, all outputs from Output Unit will be turned OFF and only the internal output status will be maintained.)
- When supplying power at 200 to 240 VAC, always remove the metal jumper from the voltage selector terminals. The product will be destroyed if 200 to 240 VAC is supplied while the metal jumper is attached.
- Always use the power supply voltages specified in the operation manuals. An incorrect voltage may result in malfunction or burning.
- Take appropriate measures to ensure that the specified power with the rated voltage and frequency is supplied in places where the power supply is unstable. An incorrect power supply may result in malfunction.
- Install external breakers and take other safety measures against short-circuiting in external wiring. Insufficient safety measures against short-circuiting may result in burning.
- Do not apply voltages to the Input Units in excess of the rated input voltage. Excess voltages may result in burning.
- Do not apply voltages or connect loads to the Output Units in excess of the maximum switching capacity. Excess voltage or loads may result in burning.
- Disconnect the functional ground terminal when performing withstand voltage tests. Not disconnecting the functional ground terminal may result in burning.

- Install the Units properly as specified in the operation manuals. Improper installation of the Units may result in malfunction.
- Be sure that all the mounting screws, terminal screws, and cable connector screws are tightened to the torque specified in the relevant manuals. Incorrect tightening torque may result in malfunction.
- Leave the label attached to the Unit when wiring. Removing the label may result in malfunction if foreign matter enters the Unit.
- Remove the label after the completion of wiring to ensure proper heat dissipation. Leaving the label attached may result in malfunction.
- Use crimp terminals for wiring. Do not connect bare stranded wires directly to terminals. Connection of bare stranded wires may result in burning.
- Wire all connections correctly.
- Double-check all wiring and switch settings before turning ON the power supply. Incorrect wiring may result in burning.
- Mount Units only after checking terminal blocks and connectors completely.
- Be sure that the terminal blocks, Memory Units, expansion cables, and other items with locking devices are properly locked into place. Improper locking may result in malfunction.
- Check switch settings, the contents of the DM Area, and other preparations before starting operation. Starting operation without the proper settings or data may result in an unexpected operation.
- Check the user program for proper execution before actually running it on the Unit. Not checking the program may result in an unexpected operation.
- Confirm that no adverse effect will occur in the system before attempting any of the following. Not doing so may result in an unexpected operation.
  - Changing the operating mode of the PC.
  - Force-setting/force-resetting any bit in memory.
  - Changing the present value of any word or any set value in memory.
- Resume operation only after transferring to the new CPU Unit the contents of the DM Area, HR Area, and other data required for resuming operation. Not doing so may result in an unexpected operation.
- Do not pull on the cables or bend the cables beyond their natural limit. Doing either of these may break the cables.
- Do not place objects on top of the cables or other wiring lines. Doing so may break the cables.
- When replacing parts, be sure to confirm that the rating of a new part is correct. Not doing so may result in malfunction or burning.
- Before touching a Unit, be sure to first touch a grounded metallic object in order to discharge any static build-up. Not doing so may result in malfunction or damage.
- When transporting or storing circuit boards, cover them in antistatic material to protect them from static electricity and maintain the proper storage temperature.
- Do not touch circuit boards or the components mounted to them with your bare hands. There are sharp leads and other parts on the boards that may cause injury if handled improperly.
- Do not short the battery terminals or charge, disassemble, heat, or incinerate the battery. Do not subject the battery to strong shocks. Doing any of these may result in leakage, rupture, heat generation, or ignition of the battery. Dispose of any battery that has been dropped on the floor or otherwise subjected to excessive shock. Batteries that have been subjected to shock may leak if they are used.

- UL standards required that batteries be replaced only by experienced technicians. Do not allow unqualified persons to replace batteries.

## 6 Conformance to EC Directives

### 6-1 Applicable Directives

- EMC Directives
- Low Voltage Directive

### 6-2 Concepts

#### **EMC Directives**

OMRON devices that comply with EC Directives also conform to the related EMC standards so that they can be more easily built into other devices or machines. The actual products have been checked for conformity to EMC standards (see the following note). Whether the products conform to the standards in the system used by the customer, however, must be checked by the customer.

EMC-related performance of the OMRON devices that comply with EC Directives will vary depending on the configuration, wiring, and other conditions of the equipment or control panel in which the OMRON devices are installed. The customer must, therefore, perform final checks to confirm that devices and the overall machine conform to EMC standards.

**Note** Applicable EMC (Electromagnetic Compatibility) standards are as follows:

EMS (Electromagnetic Susceptibility): EN61131-2

EMI (Electromagnetic Interference): EN50081-2

(Radiated emission: 10-m regulations)

#### **Low Voltage Directive**

Always ensure that devices operating at voltages of 50 to 1,000 VAC or 75 to 1,500 VDC meet the required safety standards for the PC (EN61131-2).

### 6-3 Conformance to EC Directives

The CS1-series PCs comply with EC Directives. To ensure that the machine or device in which a CS1-series PC is used complies with EC directives, the PC must be installed as follows:

- 1, 2, 3...**
1. The PC must be installed within a control panel.
  2. Reinforced insulation or double insulation must be used for the DC power supplies used for the communications and I/O power supplies.
  3. PCs complying with EC Directives also conform to the Common Emission Standard (EN50081-2). When a PC is built into a machine, however, noise can be generated by switching devices using relay outputs and cause the overall machine to fail to meet the Standards. If this occurs, surge killers must be connected or other measures taken external to the PC.

The following methods represent typical methods for reducing noise, and may not be sufficient in all cases. Required countermeasures will vary depending on the devices connected to the control panel, wiring, the configuration of the system, and other conditions.

### 6-4 Relay Output Noise Reduction Methods

The CS1-series PCs conforms to the Common Emission Standards (EN50081-2) of the EMC Directives. However, noise generated by relay output switching may not satisfy these Standards. In such a case, a noise filter must be connected to the load side or other appropriate countermeasures must be provided external to the PC.



Countermeasures taken to satisfy the standards vary depending on the devices on the load side, wiring, configuration of machines, etc. Following are examples of countermeasures for reducing the generated noise.

### Countermeasures

Refer to EN50081-2 for more details.

Countermeasures are not required if the frequency of load switching for the whole system including the PC is less than 5 times per minute.

Countermeasures are required if the frequency of load switching for the whole system including the PC is more than 5 times per minute.

### Countermeasure Examples

When switching an inductive load, connect a surge protector, diodes, etc., in parallel with the load or contact as shown below.

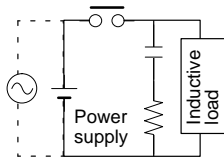
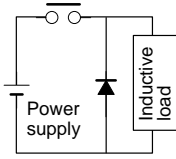
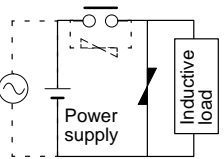
Circuit	Current		Characteristic	Required element
	AC	DC		
<p>CR method</p> 	Yes	Yes	<p>If the load is a relay or solenoid, there is a time lag between the moment the circuit is opened and the moment the load is reset.</p> <p>If the supply voltage is 24 or 48 V, insert the surge protector in parallel with the load. If the supply voltage is 100 to 200 V, insert the surge protector between the contacts.</p>	<p>The capacitance of the capacitor must be 1 to 0.5 <math>\mu\text{F}</math> per contact current of 1 A and resistance of the resistor must be 0.5 to 1 <math>\Omega</math> per contact voltage of 1 V. These values, however, vary with the load and the characteristics of the relay. Decide these values from testing, and take into consideration that the capacitance suppresses spark discharge when the contacts are separated and the resistance limits the current that flows into the load when the circuit is closed again.</p> <p>The dielectric strength of the capacitor must be 200 to 300 V. If the circuit is an AC circuit, use a capacitor with no polarity.</p>
<p>Diode method</p> 	No	Yes	<p>The diode connected in parallel with the load changes energy accumulated by the coil into a current, which then flows into the coil so that the current will be converted into Joule heat by the resistance of the inductive load.</p> <p>This time lag, between the moment the circuit is opened and the moment the load is reset, caused by this method is longer than that caused by the CR method.</p>	<p>The reversed dielectric strength value of the diode must be at least 10 times as large as the circuit voltage value. The forward current of the diode must be the same as or larger than the load current.</p> <p>The reversed dielectric strength value of the diode may be two to three times larger than the supply voltage if the surge protector is applied to electronic circuits with low circuit voltages.</p>
<p>Varistor method</p> 	Yes	Yes	<p>The varistor method prevents the imposition of high voltage between the contacts by using the constant voltage characteristic of the varistor. There is time lag between the moment the circuit is opened and the moment the load is reset.</p> <p>If the supply voltage is 24 or 48 V, insert the varistor in parallel with the load. If the supply voltage is 100 to 200 V, insert the varistor between the contacts.</p>	---

When switching a load with a high inrush current such as an incandescent lamp, suppress the inrush current as shown below.

**Countermeasure 1**

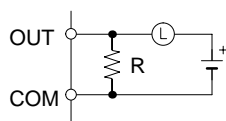

Providing a dark current of approx. one-third of the rated value through an incandescent lamp

**Countermeasure 2**

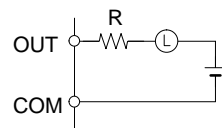

Providing a limiting resistor

# SECTION 1

## Introduction

This section describes the main features and basic functions of the DeviceNet (CompoBus/D) system and the DeviceNet (CompoBus/D) Interface Unit.

1-1	Features of the DeviceNet Interface Unit .....	2
1-2	DeviceNet Functions .....	3
1-2-1	DeviceNet Features .....	3
1-2-2	Communications Functions of Master Units .....	4
1-2-3	DeviceNet (CompoBus/D) Communications Specifications .....	6
1-3	System Configuration .....	7
1-3-1	Master Units .....	7
1-3-2	Example System Configuration .....	8
1-4	Outline of Configurator .....	9
1-5	Functions of the DeviceNet (CompoBus/D) Interface Unit .....	10
1-5-1	Communications Using the DeviceNet Interface Unit .....	10
1-5-2	Contrast with the Regular Memory Link Method .....	11

# 1-1 Features of the DeviceNet Interface Unit

The DeviceNet Interface Unit is an interface that connects PTs (Programmable Terminals) to a DeviceNet network. The DeviceNet Interface Unit can connect NT31, NT31C, NT631, and NT631C PTs.

**Compatible with Other Companies' Masters**

DeviceNet is an industry-standard network, so the DeviceNet Interface Unit is compatible with devices from different vendors. An OMRON PT can be controlled from another company's Master when it is connected to the DeviceNet network.

**Easily Connect to an Existing DeviceNet Network**

The DeviceNet Interface Unit allows a PT to be connected easily to an existing DeviceNet network. Separate PT wiring is not required and wiring work is reduced. The DeviceNet network has a maximum communications distance of 500 m, so a PT in a remote location can be controlled from the Master.

**Supports Remote I/O and Explicit Message Communications**

The DeviceNet Interface Unit supports both remote I/O communications and explicit message communications.

- Remote I/O Communications  
Remote I/O communications can exchange data (32 input words and 32 output words max.) with the PT at high speed and without programming, just like regular I/O.
- Explicit Message Communications  
More complicated control operations can be performed by sending explicit messages from the Master when required.

**Memory Link Control**

A PT connected through the DeviceNet Interface Unit can execute simulated direct access with Memory Link. The PT can be controlled from the DeviceNet Master that acts as the host by reading and writing PT memory within the PT.

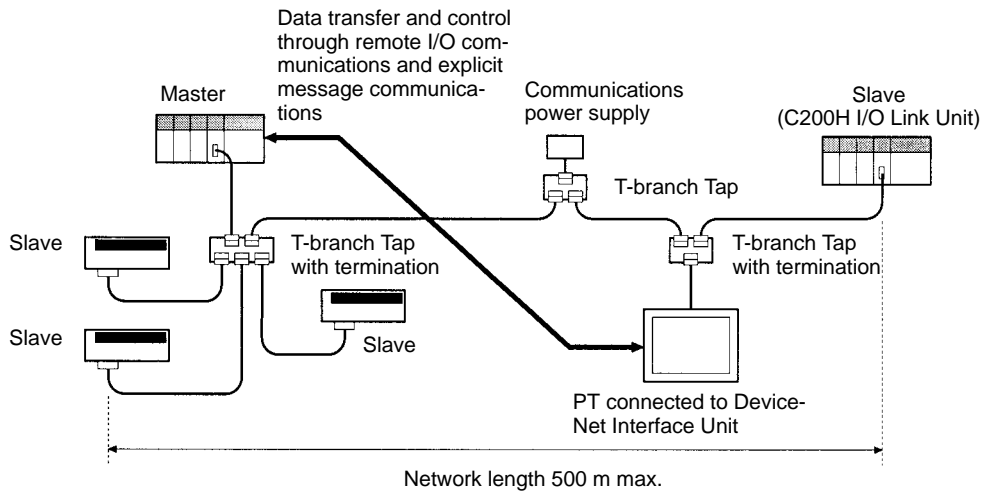

## 1-2 DeviceNet Functions

### 1-2-1 DeviceNet Features

This section explains the features of the DeviceNet network.

#### Multi-vendor Network

The DeviceNet conforms to the DeviceNet open field network specification, which means that devices (Masters and Slaves) produced by other manufacturers can be connected to the Network. A wide range of field-level applications can thus be supported by combining valve devices, sensors, and other devices.

#### Simultaneous Remote I/O and Message Services

Remote I/O communications that constantly exchange I/O data between the Master and Slaves can be executed simultaneously with message communications that send/receive Master Unit data as required by the application. A DeviceNet network can thus be installed to flexibly handle applications that require both bit data and message data.

#### Connect Multiple Masters to the Same Network

A Configurator (sold separately) can be used to enable connection of more than one Master to the Network, allowing message communications between Masters and remote I/O communications between multiple groups of Masters and Slaves. This allows the DeviceNet network to be used as a common bus to unify controls while reducing wiring.

#### Multi-layer Networks Allow Multi-point Control and Line Expansion

A Configurator (sold separately) can be used to enable mounting more than one Master Unit to a single PC, allowing control of many more points. This feature can easily handle line expansions and other applications.

#### Free Remote I/O Allocation

A Configurator (sold separately) can be used to enable flexible allocation of I/O, i.e., in any area and in any order. This allows I/O allocations that suit the application to simplify programming and enable effective usage of PC memory areas.

#### Handle Slaves with Different Response Speeds

A Configurator (sold separately) can be used to set the communications cycle time, enabling usage of Slaves with slow response times.

#### Easily Expand or Change Lines with Various Connection Methods

Use a multi-drop trunk line, T-branch multi-drop lines, or daisy-chain drop lines. All three connection methods can be combined to flexibly construct a network that meets the needs of the application.

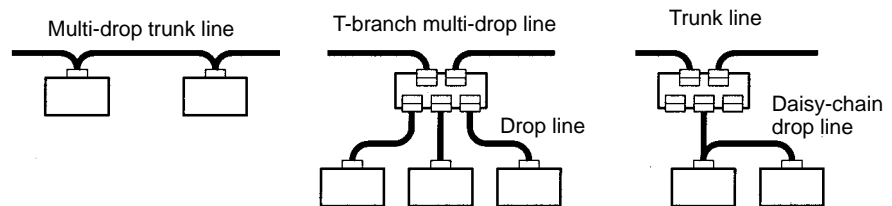

## 1-2-2 Communications Functions of Master Units

### Remote I/O Communications

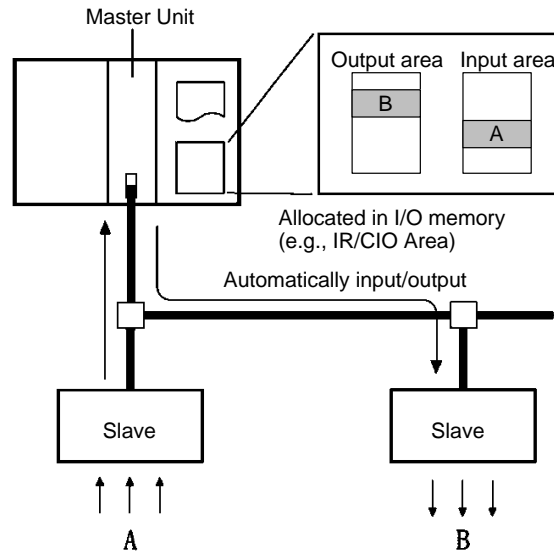

**Note** Input and output areas are automatically allocated in fixed areas unless a Configurator is used. A Configurator can be used to freely allocate input blocks 1 and 2, and output blocks 1 and 2, anywhere in I/O memory.

Item	Master Unit model	Without Configurator	With Configurator
Max. number of Slave nodes per Master	CVM1, CV Series	63 nodes	
	CS1 Series, C200HZ/HX/HG/HE	50 nodes	63 nodes
	C200HS	32 nodes	63 nodes
Max. number of control points per Master	CVM1, CV Series	2,048 pts (64 input/64 output words)	6,400 pts (100 words x 4 blocks)
	CS1 Series, C200HZ/HX/HG/HE	1,600 pts (50 input/50 output words)	Without messages: 4,800 pts With messages: 1,600 pts
	C200HS	1,024 pts (32 input/32 output words)	1,280 pts
Max. number of I/O points per Slave controllable by Master	CVM1, CV Series	32 input/32 output words	
	CS1 Series, C200HZ/HX/HG/HE		
	C200HS		
Remote I/O allocation areas	CVM1, CV Series	Fixed words in IR Area (or CIO area for CS1-series PCs)	Any area
	CS1 Series, C200HZ/HX/HG/HE		
	C200HS		

**Reference** Setting the number of words used by the DeviceNet Interface Unit changes the maximum number of Units that can be connected in a single DeviceNet Network.

Message Communications

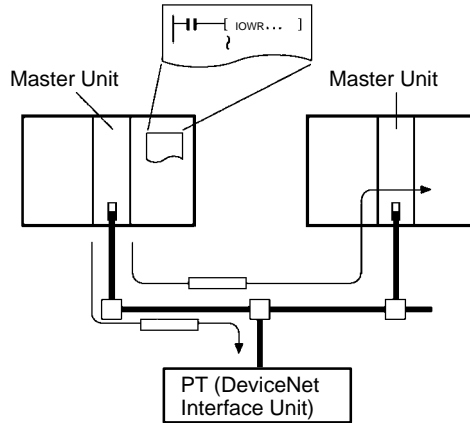

Communications Instructions

Master Unit model	Send	Receive	FINS commands
CVM1, CV Series	SEND(192)	RECV(193)	CMND(194)
CS1 Series, C200HZ/HX/HG/HE	None	None	IOWR
C200HS	---		

Item	Master Unit model	Capacity
Max. number of nodes per Master Unit for message communications using FINS commands	CVM1, CV Series	8 nodes
	CS1 Series, C200HZ/HX/HG/HE	8 nodes
	C200HS	Not supported
Max. number of nodes per Master Unit for message communications using explicit messages	CVM1, CV Series	63 nodes
	CS1 Series, C200HZ/HX/HG/HE	63 nodes
	C200HS	Not supported
Max. message length	CVM1, CV Series	SEND(192): 152 bytes RECV(193): 156 bytes CMND(194): 160 bytes (starting with command code)
	CS1 Series, C200HZ/HX/HG/HE	IOWR: 160 bytes (starting with command code)

- Reference**
1. When sending explicit messages from an OMRON Master Unit, use the EXPLICIT MESSAGE SEND (28 01) FINS command.
  2. The SEND and RECV instructions are used for communications between OMRON Master Units; they are not used with the DeviceNet Interface Unit.
  3. Explicit messages cannot be sent when a C200HS is used as the Master.

### 1-2-3 DeviceNet (CompoBus/D) Communications Specifications

Item		Specification
Communications protocol		DeviceNet
Supported connections (communications)		Master-Slave: Remote I/O and explicit messages Peer-to-peer: FINS commands (see note 1) Both conform to DeviceNet specifications
Connection forms (see note 2)		Combination of multi-drop and T-branch connections (for trunk or drop lines)
Baud rate		500 kbps, 250 kbps, or 125 kbps (switchable)
Communications media		Special 5-wire cables (2 signal lines, 2 power lines, 1 shield line)
Communications distances	500 kbps	Network length: 100 m max. (see note 3) Drop line length: 6 m max. Total drop line length: 39 m max.
	250 kbps	Network length: 250 m max. (see note 3) Drop line length: 6 m max. Total drop line length: 78 m max.
	125 kbps	Network length: 500 m max. (see note 3) Drop line length: 6 m max. Total drop line length: 156 m max.
Communications power supply		24 VDC supplied externally
Max. number of nodes		64 nodes (including Configurator when used)
Max. number of Masters		Without Configurator: 1 With Configurator: 63
Max. number of Slaves		63 Slaves
Communications cycle time (see note 4)		Without Configurator: Calculated from conditions Ex: Input Slaves (16-pt): 16 Output Slaves (16-pt) :16 Cycle time at 500 kbps: 9.7 ms  With Configurator: Set between 2 and 500 ms Calculated value takes priority if longer.
Max. communications cycle time with multiple Masters (see note 5)		Calculated from conditions. Ex: Input Slaves (16-pt): 16 Output Slaves (16-pt) :16 Max. cycle time at 500 kbps: 18 ms
Error control checks		CRC error check

- Note**
1. FINS communications are not supported by the DeviceNet Interface Unit.
  2. Terminating resistors are required at both ends of trunk line.
  3. Indicates the length when thick cables are used. Reduce the network length to 100 m max. when using thin cables. When using both thick and thin cables together, refer to *Combining Thick and Thin Cables* in 3-2-2 *Maximum Network Length*.
  4. Indicates the maximum time for remote I/O communications from a Master to a specific Slave until remote I/O communications are conducted again for the same Slave.
  5. The communications cycle time when more than one Master is present on a single network.

Refer to the *DeviceNet (CompoBus/D) Operation Manual (W267)* for other communications specifications, such as communications cycle times.



## 1-3 System Configuration

A CompoBus/D (DeviceNet) system can be constructed in two ways: fixed allocation or free allocation.

### Fixed Allocation

A DeviceNet system can be constructed easily even without the Configurator. With fixed allocation, predetermined words are allocated to each node for the Slave's I/O.

An OMRON Master Unit must be used in order to perform fixed allocation. Moreover, with fixed allocation only one Master Unit can be used in a DeviceNet network and only one Master Unit may be mounted to a PC.

### Free Allocation

The Configurator can be used to freely allocate the words used by each Slave. With free allocation, more than one Master Unit can be connected in a DeviceNet network and each Master's Slave I/O can be set independently. More than one Master Unit may be mounted to each PC and those Masters can be used independently. Furthermore, other companies' Masters can be used.

- Reference**
1. The maximum number of words occupied by the DeviceNet Interface Unit is 32 input words and 32 output words. The number of input words and output words can be set independently from 0 to 32 words. Do not allocate words that are allocated to another Slave.
  2. The maximum number of points controlled by each Master is lower with fixed allocation than it is with free allocation. When the DeviceNet Interface Unit is allocated a large number of words, do not exceed the maximum number of points that can be controlled by the Master. In particular, if a C200HS is used as the Master with fixed allocation, the DeviceNet Interface Unit will use all of the available points (32 input words and 32 output words) and it won't be possible to connect another Slave.
  3. Each Master Unit and Configurator is connected as a single node in the DeviceNet network and requires a unique node number.

### 1-3-1 Master Units

The following OMRON Master Units are available.

Applicable PC	Master Unit model number	Mounting position	Max. number of Units	
			With Configurator	Without Configurator
CVM1, CV Series	CVM1-DRM21-V1	CPU or Expansion CPU Rack (Classified as CPU Bus Units)	16	1
CS1 Series	C200HW-DRM21-V1	CPU Rack or Expansion I/O Rack (Classified as Special I/O Units)	16	
C200HZ/HX/HG/HE			10 or 16 (see note)	
C200HS			10	

**Note** Some CPUs can control 16 Master Units and other CPUs can control 10.

### 1-3-2 Example System Configuration

#### System Configuration without a Configurator (Fixed Allocation)

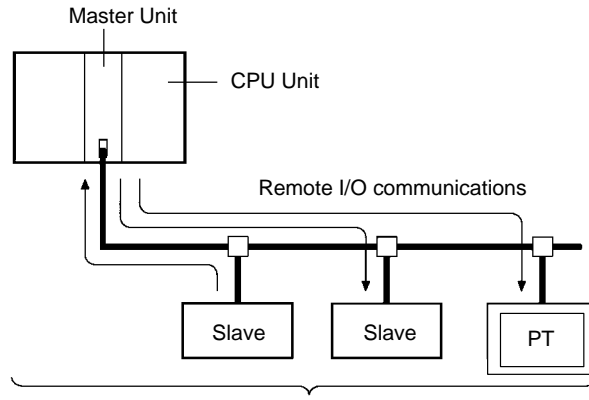

CVM1/CV-series PCs: 64 nodes max.  
CS1-series, C200HZ/HX/HG/HE PCs: 51 nodes max.  
C200HS PCs: 33 nodes max.

#### System Configuration with a Configurator (Free Allocation)

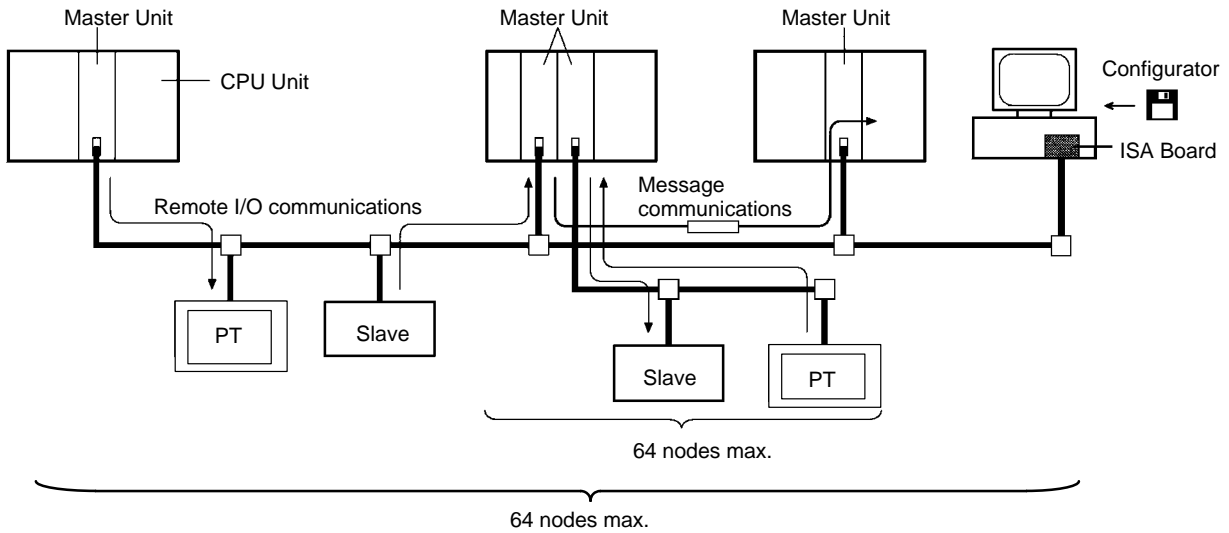

# 1-4 Outline of Configurator

The Configurator is required to use any of the following functions.

- User-set remote I/O allocations
- More than one Master Unit per PC (i.e., per CPU Unit)
- More than one Master Unit per network
- Setting communications parameters

The Configurator is run on an IBM PC/AT or compatible computer connected to the network as a DeviceNet node. Connection is made either through an ISA Board or PCMCIA Card, as shown in the following diagrams. (The Configurator can be removed from the network after settings have been completed.)

ISA Board in IBM PC/AT or Compatible

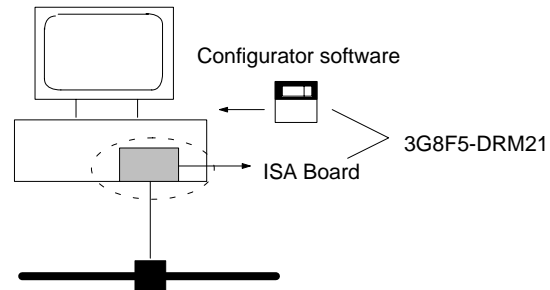

PCMCIA Card in IBM PC/AT or Compatible

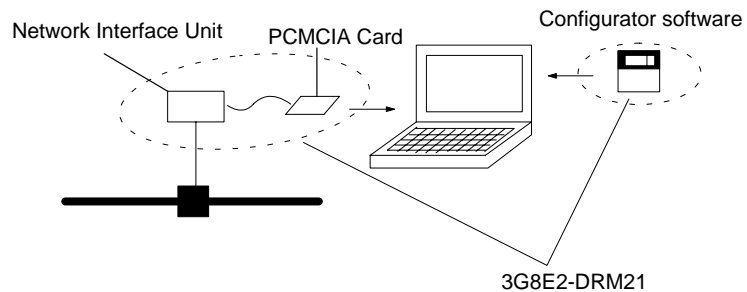

## Configurators

Model number	Components	Connector to network	Applicable computer	OS
3G8F5-DRM21	Dedicated ISA Board and Configurator Installation Disk	Dedicated ISA Board	IBM PC/AT or compatible (See "Minimum System Requirements" below.)	Windows 95 or Windows NT 3.51/4.0
3G8E2-DRM21	Dedicated PCMCIA Card and Configurator Installation Disk	Dedicated PCMCIA Card		Windows 95

### Minimum System Requirements

The minimum system requirements for an IBM PC/AT or compatible computer are as follows:

- CPU: i486/DX2 66 MHz min. (for Windows 95)  
Pentium 90 MHz min. (for Windows NT)
- Memory: 12 MB min., 16 MB recommended (for Windows 95)  
16 MB min., 24 MB recommended (for Windows NT)
- Hard disk: 5 MB of free space min.

**Main Configurator Functions**

The main functions of the Configurator are illustrated below. For details, refer to the *DeviceNet (CompoBus/D) Configurator Operation Manual (W328)*.

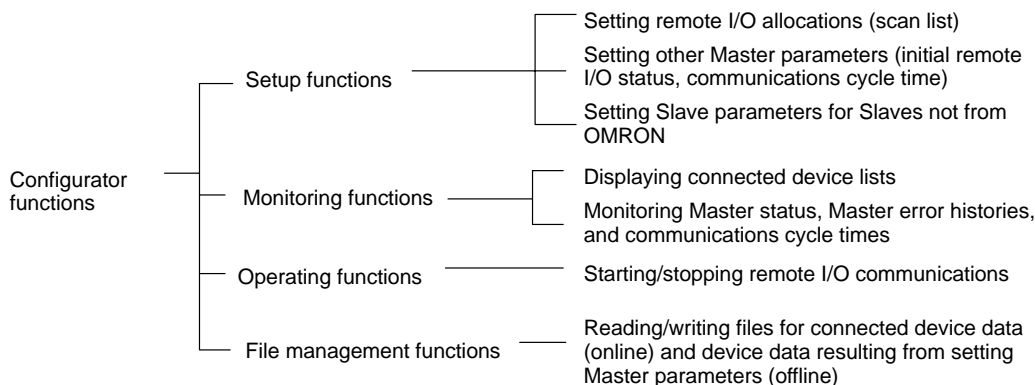

- Note**
1. Connect only one Configurator to each Network.
  2. Do not use a Configurator in locations subjected to excessive noise, particularly when using a PCMCIA Card. Excessive noise will cause the computer to run out of control. (This will not, however, adversely affect the DeviceNet network.)
  3. The OMRON Configurator can only be used for OMRON Master Units (CVM1-DRM21-V1, C200HW-DRM21-V1). Do not use the Configurator for other company's Master Units.

## 1-5 Functions of the DeviceNet (CompoBus/D) Interface Unit

A PT connected to the DeviceNet Interface Unit uses the Memory Link method. In the Memory Link method, the PT memory area within the PT is treated as a virtual PC memory area. This method allows PT memory and PT display elements to be accessed with simulated direct access.

### 1-5-1 Communications Using the DeviceNet Interface Unit

With the regular Memory Link method, the PT and host are connected through RS-232C or RS-422A communications and the host controls the PT through the PT memory by sending commands to the PT that read/write PT memory data. When a DeviceNet Interface Unit is used, the PT is connected to the host (Master) through the DeviceNet network. In contrast to the regular Memory Link method, PT memory is accessed using one of the following two methods.

**Accessing PT Memory through Input and Output Areas**

The DeviceNet Interface Unit is connected to the network as a DeviceNet Slave. As a DeviceNet Slave, the input and output areas can each contain up to 32 words.

In the DeviceNet system, the input area is regularly read by the Master and the output area is regularly written from the Master. This process maintains consistency between the Slave's input and output areas and the input and output areas allocated to the Master.

Once the PT memory's input and output areas have been set, PT memory can be read and written without having the host (Master) manage communications. The maximum size of the input and output areas is only 32 words each, but data is transferred automatically at high speed so it is useful to allocate areas that require regular data transfers with the host such as the PT status control area and PT status notify area or areas that are frequently refreshed such as the numeral memory tables.

**Accessing PT Memory with Explicit Message Communications**

Parts of PT memory other than the input and output areas can be read/written by sending explicit messages from the host.

Transferring data with explicit message communications takes more time than transferring data with the input and output areas, but all of PT memory can be accessed.

If explicit message communications are used as the main method to transfer data, the DeviceNet Interface Unit's input and output areas can be reduced to their minimum required sizes and more input and output area capacity will be available for other Slaves.

**Note** Observe the following precautions in order to minimize the communications time required for explicit message communications.

- Limit the amount of data transmitted in each message communications event.
- Consider setting the ladder program in the host that controls the DeviceNet Interface Unit so that it transfers just the data in the displayed screen. (In this case, it will be necessary to write a ladder program section for each screen.)

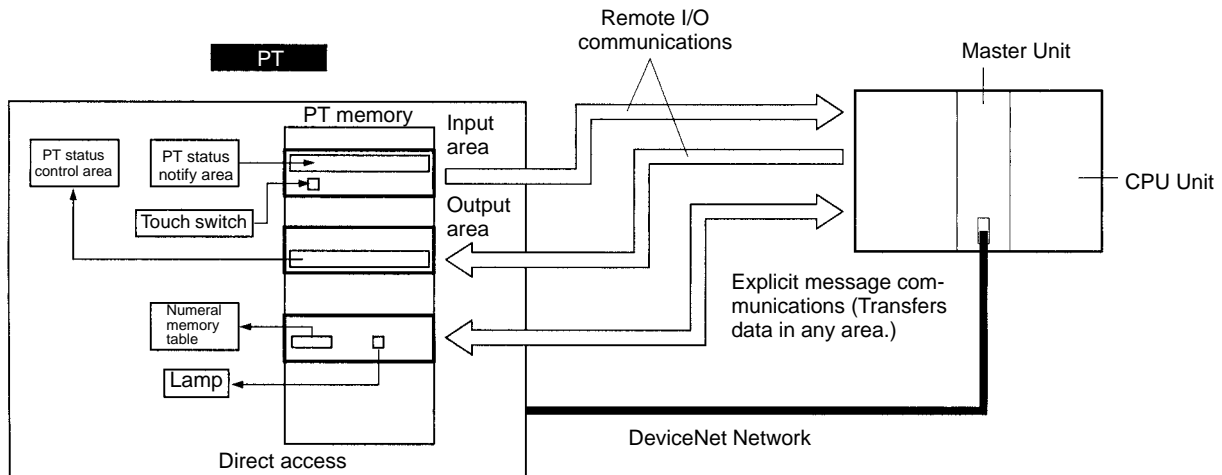

### 1-5-2 Contrast with the Regular Memory Link Method

The following operations are different with the DeviceNet Interface Unit and with regular Memory Link method.

- The transmission direction of the input area is always PT → Host and that of the output area is always Host → PT, so two-way functions cannot be used when using the input and output areas.
- Except for remote I/O communications, no locally-initiated communications functions are supported by the DeviceNet Interface Unit. With explicit message communications, communications are always executed by commands sent from the host and corresponding responses from the PT.
- Since the DeviceNet Interface Unit does not support locally-initiated communications functions other than remote I/O communications, it is necessary to set the strobe ON interval to match system requirements and always read the status of the strobe at the Master. (Set the interval in the system menu.)

The following table lists the operational differences between the regular Memory Link and the DeviceNet Interface Unit's Memory Link that arise due to differ-

ences described above and differences in the hardware used for communications.

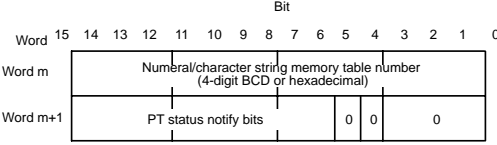
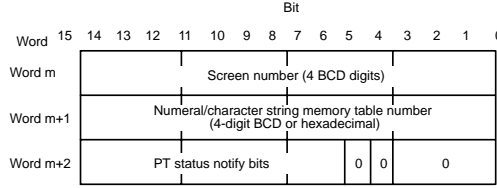
Item	With Regular Memory Link	With DeviceNet Interface Unit
Communications with host (method used to read/write PT memory)	Data transfer by Memory Link commands via RS-232C or RS-422A communications	<ul style="list-style-type: none"> <li>Data transfer through the DeviceNet input and output areas (The contents of corresponding words in the host are updated automatically.)</li> <li>Data transfer by explicit message communications</li> </ul> <p>Refer to 1-5-1 Communications Using the DeviceNet Interface Unit for more details.</p>
Functions possible between the PT and host	<p>The following functions can be executed with the Memory Link command:</p> <ul style="list-style-type: none"> <li>Read/write PT memory, numeral memory tables, character string tables, or bit memory tables.</li> <li>Clear numeral memory tables, character string tables, or bit memory tables.</li> <li>Notify the host of a touch switch, numeral, or character input.</li> <li>Notify the host of a change in the direct area or PT memory.</li> <li>Change the PT's operating mode.</li> <li>Send a resend request to the PT.</li> <li>Return an error response to an illegal command from the host.</li> </ul>	<p>The following functions can be executed by sending explicit messages:</p> <ul style="list-style-type: none"> <li>Read/write PT memory. (Data is automatically transferred through the input and output areas. Data can be transferred to or from any area with explicit message communications.)</li> </ul>
Structure of the PT status notify area		
PT status notify area's "Displayed screen number"	None (The current screen number can be found in the PT status control area's "screen number".)	Notify the host of the displayed screen number.
Strobe of the PT status notify area's "PT status notify bit"	The strobe goes ON for a fixed time when the displayed screen is changed or the contents of the numeral or character string memory table are changed. (At the same time, the host is notified by the Memory Link command.)	The strobe goes ON for time set in the system menu. (There is no notification to the host. The strobe's ON time must be longer than the interval between data reads from the host.)
Window control area	<p>Normally, this area is used in both directions and the contents of this area are mirrored in the corresponding area in the host.</p> <ul style="list-style-type: none"> <li>Specification of the displayed window from the host to the PT</li> <li>Notification of the displayed window from the PT to the host</li> </ul>	<ul style="list-style-type: none"> <li>When allocated to the input area, only notification of the displayed window from the PT to the host is performed.</li> <li>When allocated to the output area, only specification of the displayed window from the host to the PT is performed.</li> <li>When allocated to an area other than the input or output area, it is necessary to regularly read the contents to recognize changes and write data to control the displayed window.</li> </ul>
Notification to the host	Notify the host with the notification command.	None. (The user must confirm contents by regularly reading data at the locations where changes are expected or allocating part of the input area so that data is read automatically.)
System program in the PT	Use the factory-installed system program or the system program included with the Support Tool.	Install the system program included with the DeviceNet Interface Unit.

Item	With Regular Memory Link	With DeviceNet Interface Unit
Simultaneous use with the Memory Unit	Possible	The Memory Unit cannot be used because the DeviceNet Interface Unit also uses the Expansion Interface Connector on the back of the PT. (It is possible to reconnect the Memory Unit and save data such as the DeviceNet Interface Unit's screen data.)
Use of the RS-422A port	Possible (for communications with the host)	Not possible (A bar code reader or computer running Support Tool can be connected to the RS-232C port.)

Any functions that are not listed in the table above are identical with the regular Memory Link and the Memory Link used with the DeviceNet Interface Unit. Communications between the PT and host are different between the regular Memory Link and the Memory Link used with the DeviceNet Interface Unit, but data exchange between the PT (parts, memory tables, etc.) and PT memory are the same.

This manual explains only the functions particular to the DeviceNet Interface Unit and their usage. Refer to the appropriate manual listed below for details on procedures such as operating the PT and creating screens.

- NT31/NT31C setup and connections:  
NT31/NT31C Setup Manual (V062)
- NT631/NT631C setup and connections:  
NT631/NT631C Setup Manual (V063)
- NT31/NT31C and NT631/NT631C functions and control:  
NT31/NT631 Reference Manual (V064)
- Support Tool operations and operations such as creating screens:  
NT-series Support Tool Operation Manual (V061)

**Note** The manuals listed above cover the “-V2” versions of the NT31/NT31C and NT631/NT631C, but the PT will operate as a “-V1” version when the DeviceNet Interface Unit is connected so some functions listed in the manuals will not be usable. Refer to Appendix B for details on differences between functions in the “-V1” versions (system version 2.1) and the “-V2” versions.

## SECTION 2

# Operating Procedures

This section shows a simple system configuration example and basic procedures up to using the PT connected to the Device-Net Interface Unit.

2-1	Operating Procedures Flowchart .....	16
2-1-1	PT Settings Procedure .....	16
2-1-2	Flowchart .....	17
2-1-3	Preparations prior to Communications .....	18
2-1-4	Setting Up Communications .....	18
2-1-5	Starting Remote I/O Communications During Operation .....	20
2-2	Simple System Configuration .....	20



## 2-1 Operating Procedures Flowchart

This section shows a flowchart of the basic operating procedures up to using the PT connected to the DeviceNet Interface Unit.

### 2-1-1 PT Settings Procedure

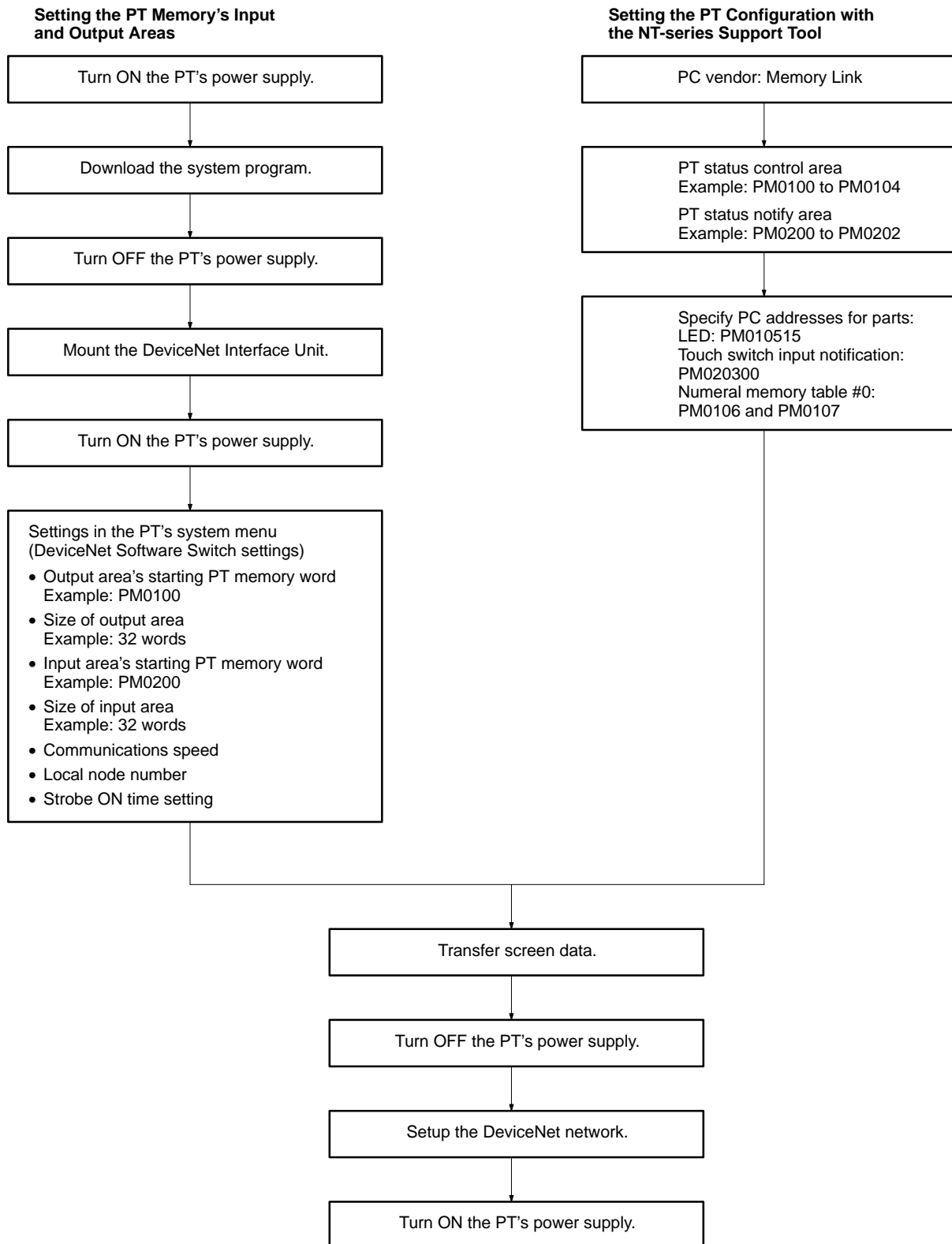

### 2-1-2 Flowchart

The following flowchart outlines the basic flow of operations for setting up the DeviceNet system.

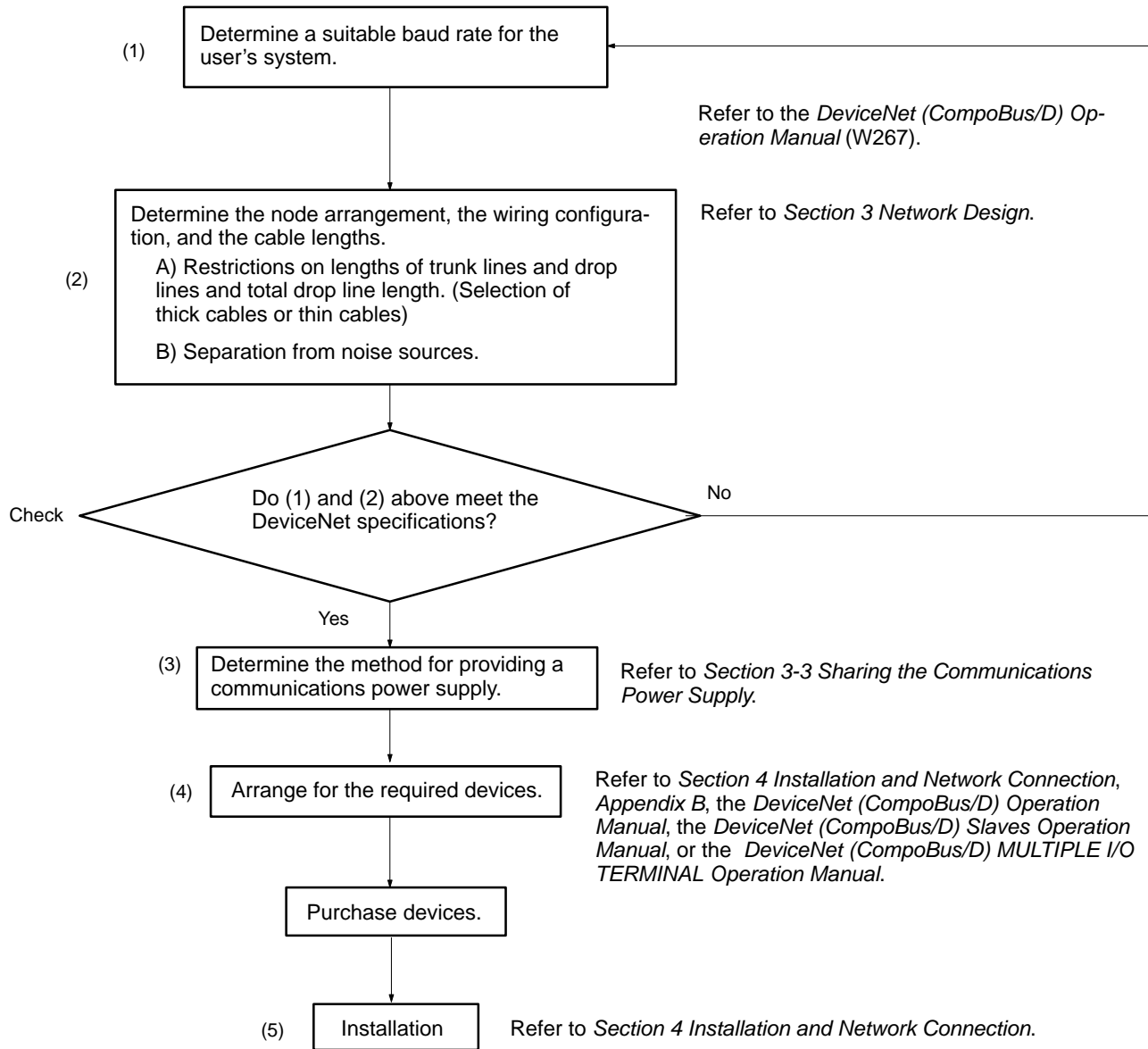

## 2-1-3 Preparations prior to Communications

- 1, 2, 3...
1. Set the initial settings for the Master Unit:
    - Unit number ("UNIT No." or "MACHINE No." on front panel switch)
    - Node address (back panel DIP switch)
    - Baud rate (back panel DIP switch)
    - Communications continue/stop setting for communications error (front panel switch)
  2. Mount the Master Unit and wire the Network.
    - For CVM1 and CV-series PCs, Master Units are treated as CPU Bus Units and can be mounted to the CPU Rack or Expansion CPU Rack. Only one Master Unit can be mounted if a Configurator is not used, but up to 16 Master Units can be mounted if a Configurator is used.
    - For C200HX/HG/HE PCs, Masters are treated as Special I/O Units and can be mounted to the CPU Rack or Expansion I/O Rack. Only one Master Unit can be mounted if a Configurator is not used, but up to 10 or 16 Master Units can be mounted if a Configurator is used.
    - For CS1-series PCs, Masters are treated as Special I/O Units and can be mounted to the CPU Rack or Expansion I/O Rack. Only one Master Unit can be mounted if a Configurator is not used, but up to 16 Master Units can be mounted if a Configurator is used.
    - For C200HS PCs, Masters are treated as Special I/O Units and can be mounted to the CPU Rack or Expansion I/O Rack. Only one Master Unit can be mounted if a Configurator is not used, but up to 10 Master Units can be mounted if a Configurator is used.
  3. Connect a Programming Device to the PC and turn ON the power supply to the PC.
  4. Generate the I/O table.

## 2-1-4 Setting Up Communications

### Remote I/O Communications with One Master Unit in the Network

#### Using Fixed I/O Allocations

Always operate with the scan list enabled. Refer to the *DeviceNet (Compo-Bus/D) Operation Manual (W267)* for details on connecting more than one Master Unit in a single network.

- 1, 2, 3...
1. Turn ON the communications power supply and then the power supply to the Slaves (i.e., the PT).
  2. Turn ON the power supply to the Master (i.e., the PC).
  3. Switch the PC to PROGRAM mode.
  4. If the scan list was disabled at startup, perform the following and go to step 7. (Otherwise, proceed to step 5.)
    - a) Confirm that communications are possible with the registered Slaves (i.e., the PT) by monitoring the Master's Registered Slave Data Area.
    - b) From a Programming Device connected to the PC, turn ON the Scan List Enable Bit in the Master's software switches (bit 0).

Remote I/O communications will start with the scan list enabled. You can use the Master's software switches to start and stop remote I/O communications.
  5. If the scan list was disabled at startup and you want to re-register it, perform the following from a Programming Device connected to the PC and go to step 7. (Otherwise, proceed to step 6.)
    - a) Turn ON the Scan List Clear Bit in the Master's software switches (bit 1).
    - b) Confirm that communications are possible with the registered Slaves by monitoring the Master's Registered Slave Data Area.

- c) Turn ON the Scan List Enable Bit in the Master's software switches (bit 0).

Remote I/O communications will start with the scan list enabled. You can use the Master's software switches to start and stop remote I/O communications.

6. Do nothing if the scan list was enabled at startup and you do not want to change it.

Remote I/O communications will start with the scan list enabled. You can use the Master's software switches to start and stop remote I/O communications. Go to step 7.

7. Confirm that the MS and NS indicators on all Master Units and Slaves (i.e., the PT) are lit green.  
8. Switch the PC to RUN mode.

**Note** The dots on the 7-segment display on the Master Unit can be used to determine if the scan list is enabled or disabled. If both the right and left dots are not lit, the scan list is enabled. If both dots are lit, the scan list is disabled.

### Using Free (User-set) I/O Allocations

Always operate with the scan list enabled. Refer to the *DeviceNet (Compo-Bus/D) Operation Manual (W267)* for details on connecting more than one Master Unit in a single network.

- 1, 2, 3...**
1. Connect a Configurator to the Network.
  2. Turn ON the communications power supply and then the power supply to the Slaves (i.e., the PT).
  3. Turn ON the power supply to the Master (i.e., the PC).
  4. Switch the PC to PROGRAM mode.
  5. Create the Master parameters with the Configurator.
  6. Register the Master parameters in the Master Unit.  
Remote I/O communications will start with the scan list enabled. (Communications will not start at if they have been set to be stopped at startup from the Configurator.) Use the software switches or Configurator to start and stop remote I/O communications.
  7. Confirm that the MS and NS indicators on all Master Units and Slaves (i.e., the PT) are lit green.
  8. Read the Network configuration from the Configurator.
  9. Save the Network configuration in a file from the Configurator.
  10. Switch the PC to RUN mode.

## 2-1-5 Starting Remote I/O Communications During Operation

- 1, 2, 3...**
1. Turn ON the communications power supply and then the power supply to the Slaves (i.e., the PT).
  2. Turn ON the power supply to the Master (i.e., the PC).
  3. Switch the PC to RUN mode.

**Reference** It is alright to turn ON the following power supplies simultaneously. If the power supplies cannot be turned ON simultaneously, turn them ON in the order listed above.

Communications power supply and Slave (PT) power supply  
Slave (PT) power supply and Master Unit (PC) power supply  
All three power supplies

### Precautions

Observe the following precautions:

- Use a DC power supply with low voltage fluctuation.
- If the Slave's (PT's) power supply is turned ON before the communications power supply, the Slave (PT) might not be added to the network. Turn the power supplies ON simultaneously or turn ON the communications power supply first.
- Always operate the Master Unit with the scan list enabled.  
By operating with the scan list enabled, the Master can determine whether or not the Slave (PT) is participating in the network so the user can check whether the DeviceNet network is operating normally.

## 2-2 Simple System Configuration

OMRON manufactures a variety of devices that are compatible with the DeviceNet standard, including devices that handle bit I/O, temperature inputs, analog I/O, and other functions. Moreover, devices manufactured by other companies can be connected if they conform to DeviceNet standards.

It is also easy to change the configuration of a DeviceNet network since just one cable is required for wiring.

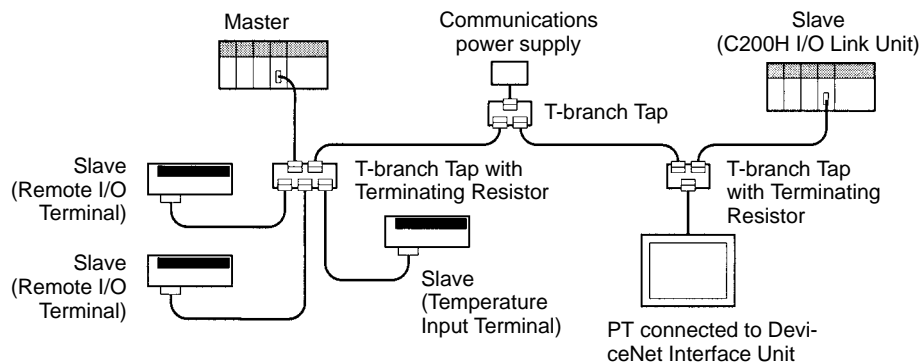

A PT connected to the network through a DeviceNet Interface Unit can perform some of the functions of a control panel, such as switch operations and numeric inputs as well as displaying the system's operating status.

# SECTION 3

## Network Design

This section provides information required when designing a network, such as precautions regarding the configuration of the DeviceNet network to which the CompoBus/D Interface Unit connects.

3-1	Network Configuration .....	22
3-1-1	Network Components .....	22
3-1-2	Connections .....	23
3-2	Limitations on the Network Configuration .....	24
3-2-1	Baud Rate and Communications Distance .....	24
3-2-2	Maximum Network Length .....	24
3-2-3	Drop Line Lengths .....	25
3-2-4	Total Drop Line Length .....	26
3-2-5	Locating Terminating Resistors .....	26
3-3	Sharing the Communications Power Supply .....	27
3-3-1	Prerequisite Conditions .....	27
3-3-2	Determining the Communications Power Supply Method .....	28
3-3-3	Locating the Power Supply .....	29
3-3-4	Step 1: Determining the Best Location for the Power Supply from a Graph .....	30
3-3-5	Step 2: Calculating the Best Location of the Actual Nodes .....	33
3-3-6	Step 3: Splitting the System into Multiple Power Supplies .....	36
3-3-7	Dual Power Supply .....	37
3-4	Grounding the Network .....	37
3-4-1	Ground Wire Connection .....	38
3-5	Noise Precautions .....	38
3-6	Correcting Faulty Operation Caused by Noise .....	40
3-7	Sharing the Same Power Supply .....	40

## 3-1 Network Configuration

The following diagram shows the configuration of a DeviceNet network.

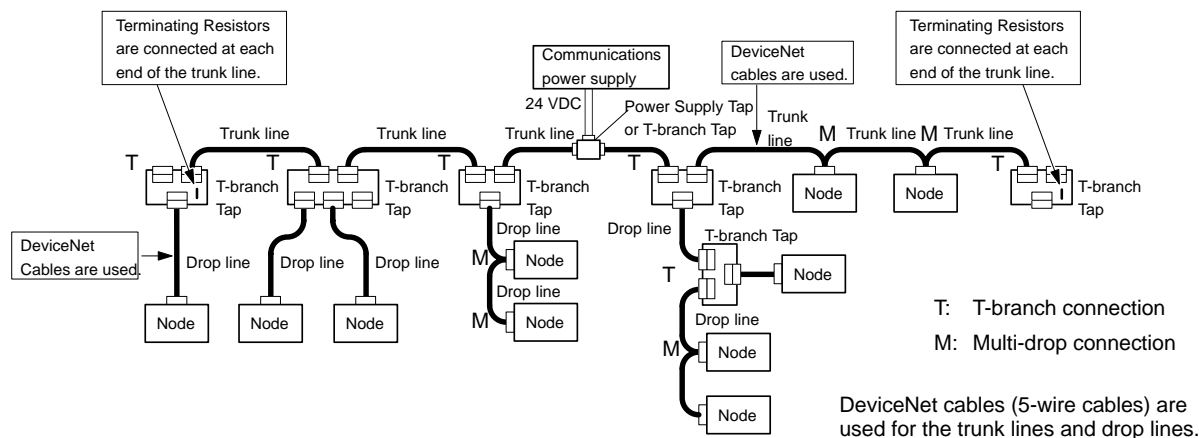

### 3-1-1 Network Components

#### Nodes

There are two kinds of nodes in a DeviceNet network. The Slaves connect to external I/O and the Master administers the Network and manages the external I/O of the Slaves. (There are also Slaves that exchange data with devices such as the CPU Unit and PTs.) The Master and Slaves can be connected at any location in the Network, as shown in the preceding diagram.

#### Trunk/Drop Lines

The trunk line refers to the cable that has Terminating Resistors on both ends. Cables branching from the trunk line are known as drop lines. The trunk line length does not necessarily coincide with the maximum length of the Network. DeviceNet communications are transmitted through 5-wire cables. The cables come in thick or thin versions.

#### Connection Methods

Two methods can be used to connect DeviceNet nodes: The T-branch method and the multi-drop method. With the T-branch method, the node is connected to a drop line created with a T-branch Tap. With the multi-drop method, the node is directly connected to the trunk line or the drop line. Secondary branches can be made from a drop line. Both of these connection methods can be used in the same Network, as shown in the example.

#### Terminating Resistors

Terminating Resistors are connected at each end of the trunk line to reduce signal reflection and stabilize communications. There are two kinds of Terminating Resistors available, one for a T-branch Tap and one for a Terminating-block Terminating Resistor. Use a DeviceNet cable when connecting a Terminating-block Terminating Resistor.

#### Communications Power Supplies

To use DeviceNet, connect a communications power supply to the communications connector of each node with a 5-wire cable. Basically, a communications power supply, internal circuit power supply, and I/O power supply must be provided separately. (Refer to 3-7 *Sharing the Same Power Supply* for details.)

#### Note

1. Always use 5-wire DeviceNet cables.
2. Connect Terminating Resistors to both ends of the trunk line. When using a Terminating-block Terminating Resistor, use a DeviceNet cable to connect the Terminating Resistor. When connecting the Terminating Resistor, insulate the power supply lines that are not being used with vinyl electrical tape to avoid a short-circuit in the cables.
3. Do not use products other than DeviceNet products (for example, a lightning arrester) in the communications path. Using other products can interfere with normal communications by causing signal reflections and other problems.





## 3-2 Limitations on the Network Configuration

### 3-2-1 Baud Rate and Communications Distance

The communications distance in a DeviceNet network is also restricted by the baud rate, as shown in the following table.

Baud rate	Maximum network length		Drop line length	Total drop line length
	Thick cable	Thin cable		
500 kbps	100 m max.	100 m max.	6 m max.	39 m max.
250 kbps	250 m max.			78 m max.
125 kbps	500 m max.			156 m max.

**Note** Always keep the communications distance within the limits shown in this table.

### 3-2-2 Maximum Network Length

The length of the network is longest at either the distance between the two most distant nodes or at the distance between the Terminating Resistors.

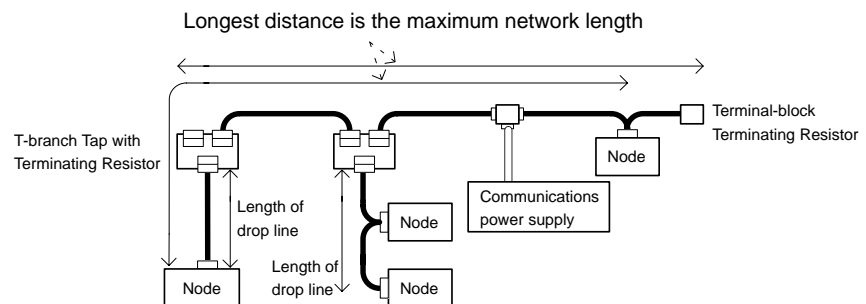

There are two types of cables: Thick cables and thin cables. The thick cables are relatively hard and inflexible, but they protect against signal attenuation and can be used for relatively long communications distances. The thin cables are soft and flexible, but they do not protect as well against signal attenuation and are not suited to long communications distances.

The maximum length of a network thus depends on the type of cable that is used, as shown in the following table.

Cable type	Maximum network length
Thick cables (5-wire)	500 m
Thin cables (5-wire)	100 m

- Reference**
- a) If the length of the network is 100 meters or less, the thin cables can be used for the trunk line. When using thin cables for the trunk line, be sure that communications power supply conditions are met. Refer to 3-3 *Sharing the Communications Power Supply*.
  - b) The length of the network is also restricted by the baud rate used. Even with thick cables, the length of the network will be restricted if the baud rate is set to anything but 125 kbps. Refer to 3-2-1 *Baud Rate and Communications Distance* above.

**Note Combining Thick and Thin Cables**

The most distant nodes can also be connected by a combination of thin and thick cables. When these cables are combined, the following conditions must be met and the maximum network length will be shorter than when only thick cables are used. Also, when combining cables, be sure that the maximum current capacity of the cables is not exceeded. Refer to 3-3 *Sharing the Communications Power Supply*.

Baud rate	Maximum network length
500 kbps	$L_{THICK} + L_{THIN} \leq 100$ m
250 kbps	$L_{THICK} + 2.5 \times L_{THIN} \leq 250$ m
125 kbps	$L_{THICK} + 5 \times L_{THIN} \leq 500$ m

$L_{THICK}$ : Length of the thick cable;  $L_{THIN}$ : Length of thin cable

**Configuration Example**

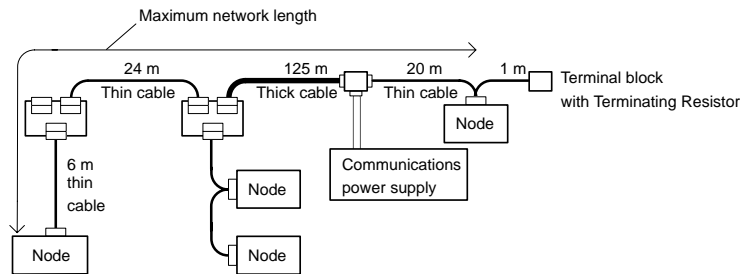

$L_{THICK} + L_{THIN} = 175 \leq 100$ m	500 kbps	NG
$L_{THICK} + 2.5 \times L_{THIN} = 125 + 2.5 \times 50 = 250 \leq 250$ m	250 kbps	OK
$L_{THICK} + 5 \times L_{THIN} = 125 + 5 \times 50 = 375 \leq 500$ m	125 kbps	OK

The results of the above formulas indicate that 250 kbps and 125 kbps can be used as the baud rates for this configuration example.

Even when the above conditions are met, however, the current flowing through the cables must not exceed the permissible current capacity. ( Refer to 3-3 *Sharing the Communications Power Supply*.)

**3-2-3 Drop Line Lengths**

A drop line length is measured from the point in the trunk line where the original branch was made to the end of the branch. The maximum length of a drop line is 6 m. It is possible to make a secondary branch from a drop line.

### 3-2-4 Total Drop Line Length

This is the total sum length of all the drop lines. Even when the length of each individual drop line is 6 m or less, be sure not to exceed the maximum total drop line length. The maximum total drop line length varies with the baud rate as shown in the following table.

Baud rate	Total drop line length
500 kbps	39 m max.
250 kbps	78 m max.
125 kbps	156 m max.

#### Configuration Example

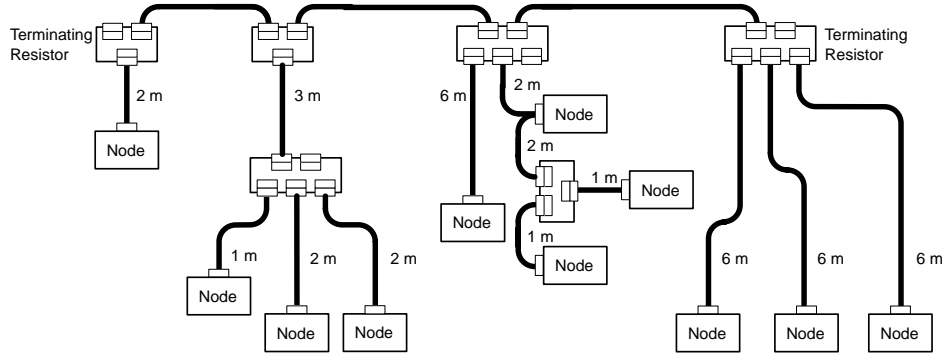

In the configuration example, the length of each drop line is 6 m or less as demanded but the total sum length of all the drop lines is 40 m. Set the baud rate at 250 kbps or 125 kbps because the total maximum length of drop lines at 500 kbps must not exceed 39 m.

### 3-2-5 Locating Terminating Resistors

Be sure to connect the Terminating Resistors at both ends of the trunk line to reduce signal reflection and stabilize communications.

When there is a T-branch Tap 6 meters or less from the end of the trunk line (or the node):

A Terminating Resistor attached to a T-branch Tap can easily be mounted without taking up much space.

When there is not a T-branch Tap 6 meters or less from the end of the trunk line (or the node):

A Terminating Resistor must be connected before that point. Either a T-branch Tap mounted to a Terminating Resistor or a Terminating-block Terminating Resistor can be used. In this case, be sure to make the cable length 1 m or less from the node to the Terminating Resistor.

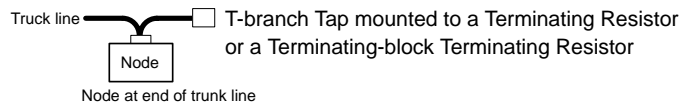

## 3-3 Sharing the Communications Power Supply

It is necessary to supply communications power to each node in the DeviceNet network.

### 3-3-1 Prerequisite Conditions

- The communications power supply must be 24 VDC.
- The communications power supply must be connected to the trunk line.
- When providing power to several nodes from one power supply, if possible try to locate the nodes in both directions from the power supply.
- Provide power through Power Supply Taps. It is, however, possible to use T-branch Taps instead when there is one communications power supply in the system and the total current consumption is less than 5 A.
- The power supply capacity for cables is restricted to 8 A for thick cables and 3 A for thin cables.
- A single network is usually supplied by one power supply. It is, however, possible to have more than one power supply when power supply specifications cannot be met with a single power supply. (See 3-3-6 Step 3: *Splitting the System into Multiple Power Supplies.*)
- Fully consider the power supply capacity allowance in the design.
- If the power supply is switched OFF during the operation of the network, there may be a malfunction in the nodes.
- The current capacity of the drop line varies according to its length. The longer the drop line, the lower its maximum capacity becomes. This is the same whether the cable is thick or thin. Calculate the current capacity passing through the drop line I (the total current consumption at the drop line) using the following formula.

$$I = 4.57/L$$

I: Permissible current (A)

L: Length of the drop line (m)

### 3-3-2 Determining the Communications Power Supply Method

This section provides a basic flow chart to determine which communications power supply method to use. Use the flow chart below to determine the communications power supply on the trunk line. The current carried by each drop line must be less than the permissible current which can be calculated with the formula on page 27.

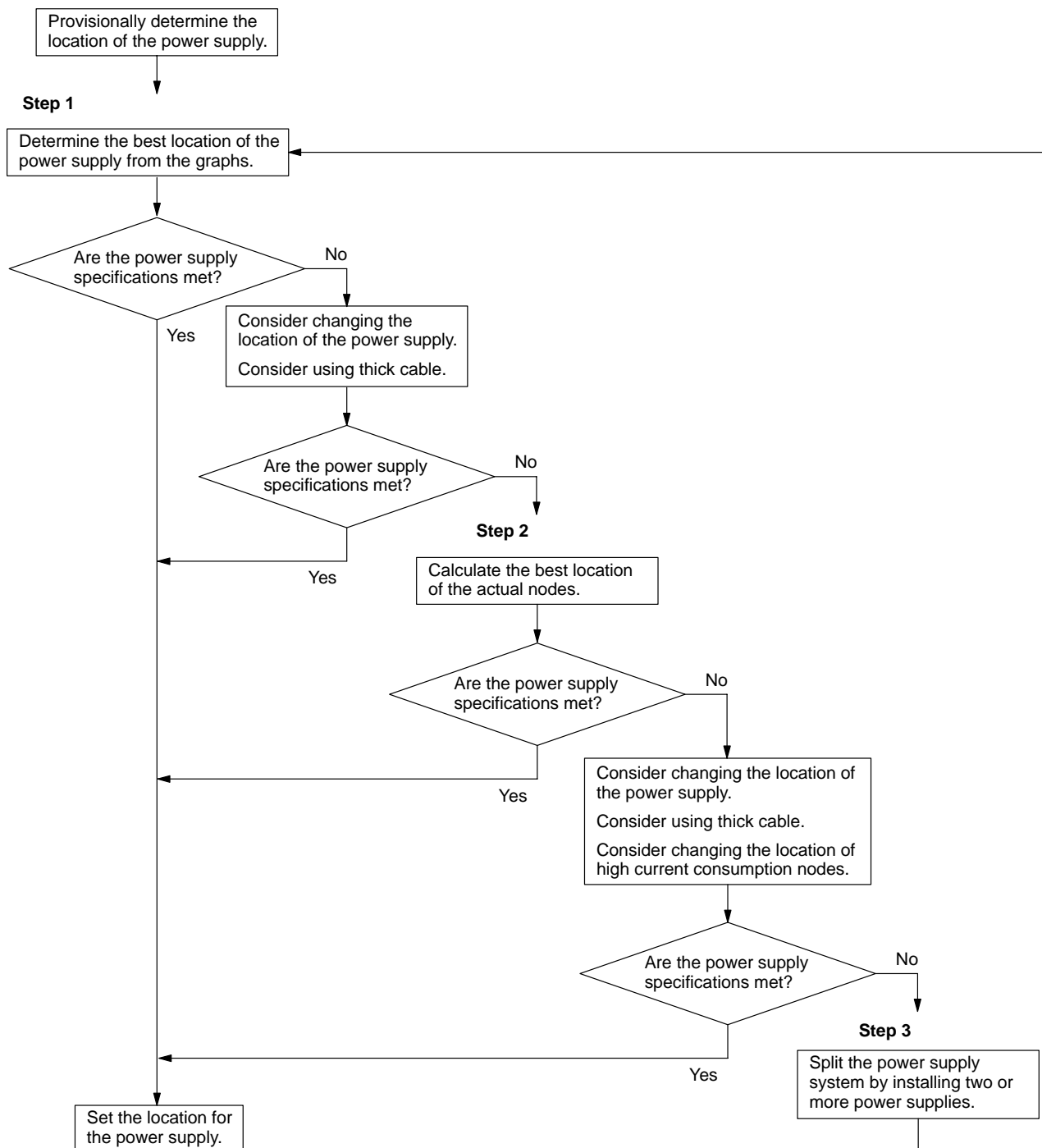

### 3-3-3 Locating the Power Supply

#### Power Supply Location Patterns

The power supply can be located in the configurations shown below. Basically, select from the configurations 1. and 2.

Consider using configuration 3. when power supply specifications cannot be met by configurations 1. and 2. It is possible to use configuration 4. for a duplex power supply. Refer to sections 3-3-4 to 3-3-6 for more details concerning each configuration.

#### 1, 2, 3... 1. Locating the Nodes on Both Sides of the Power Supply

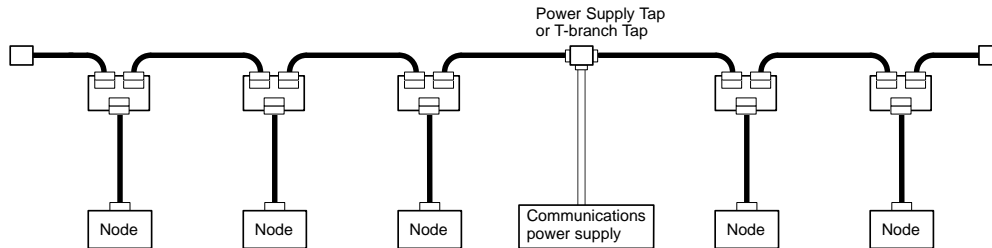

#### 2. Locating the Nodes on One Side of the Power Supply

**Note** Configuration 1. is recommended for a single power supply to several nodes.

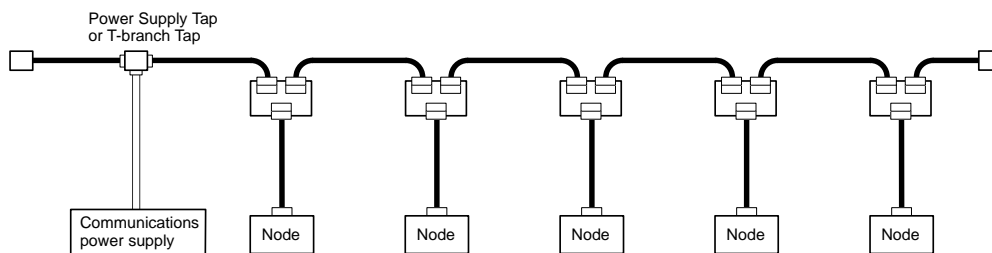

#### 3. Splitting the Power Supply System with Multiple Power Supplies

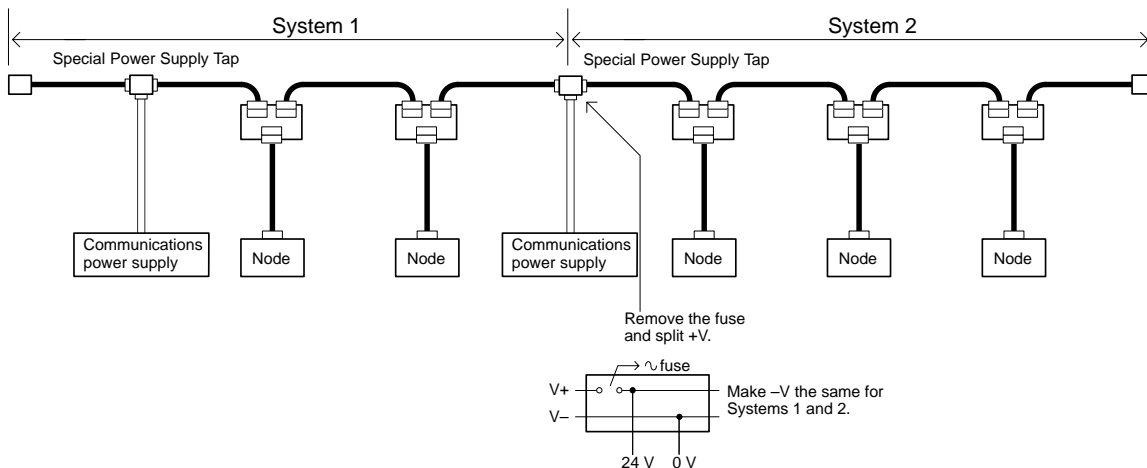

#### 4. Duplex Power Supply with Multiple Power Supplies

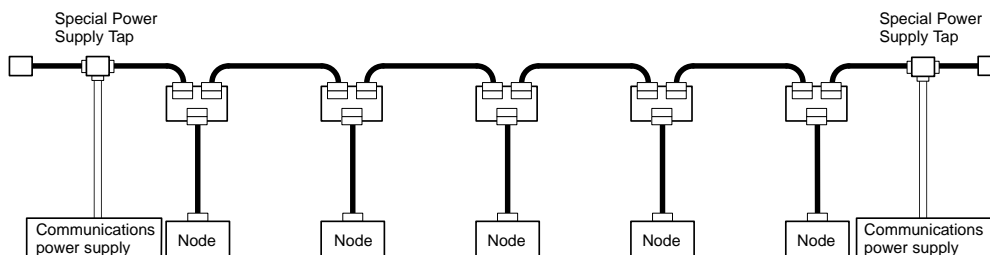

**Note** If power supply specifications cannot be met with a single power supply when the current capacity of the thick cable exceeds 8 A even after the power supply location is modified, use more than one communications power supply. In configuration 1, the power can be supplied bi-directionally to the trunk line as long as each current capacity is 8 A or less when using thick cable. Accordingly, it is possible to have a configuration with a total maximum current capacity of up to 16 A. Consider changing to thick cable to meet specifications if the current capacity of the thin cable exceeds 3 A when using thin cable for the trunk line.

### Setting the Location of the Power Supply

Determine whether or not the current can be supplied normally by finding the current capacity required by each node and the voltage drop in the cables to be used to provide power. Calculate the values below in advance.

- The current capacity required by each node
- The distance between the power supply and each node

The current capacity of the DeviceNet Interface Unit is 45 mA.

### Calculating the Location of the Power Supply

There are two methods to find the best location of the communications power supply on the trunk line.

- Simple calculation from a graph
- Calculation by formula (Calculating the voltage drop from resistance and current consumption of the communications cables).

Each drop line must satisfy the equation on page 27, which represents the relationship between the drop line length and the current capacity for the drop line.

- From the graph, a hypothetical power supply location can be determined if the conditions calculated in the graph are met by estimating the worst configuration (that has the maximum voltage drop as shown in the diagram below).

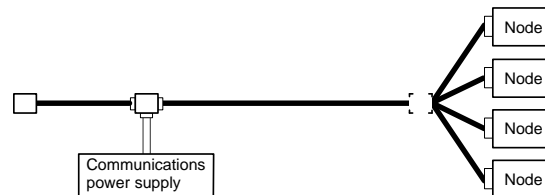

- Even if the power supply specifications cannot be met using the graph, the conditions can be met and a hypothetical power supply location determined by using the formula.

**Note** When the communications power supply and the internal circuit supply are the same, use the formula to calculate a hypothetical power supply location because it cannot be determined by using the graph.

## 3-3-4 Step 1: Determining the Best Location for the Power Supply from a Graph

A voltage drop occurs when a current flows through a communications cable. The longer the communications cable, the greater the voltage drop. The communications power supply at each node must be 11 VDC or more. To ensure this, the relationship is plotted as shown in the graph below to find the maximum current that satisfies the voltage of the communications power supply at different trunk line lengths even if there is a voltage drop due to cable resistance.

**Thick Cable**

Distance (m)	0	25	50	100	150	200	250	300	350	400	450	500
Max. current (A)	8.00	8.00	5.42	2.93	2.01	1.53	1.23	1.03	0.89	0.78	0.69	0.63

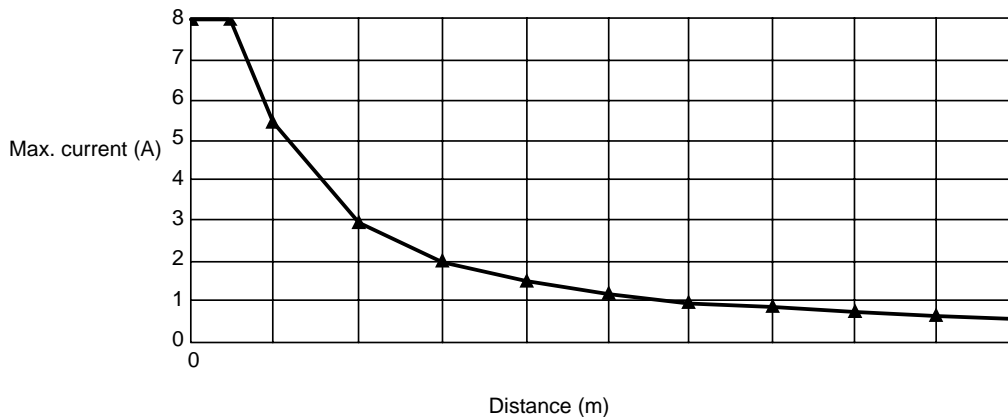

**Thin Cable**

Distance (m)	0	10	20	30	40	50	60	70	80	90	100
Max. current (A)	3.00	3.00	3.00	2.06	1.57	1.26	1.06	0.91	0.80	0.71	0.64

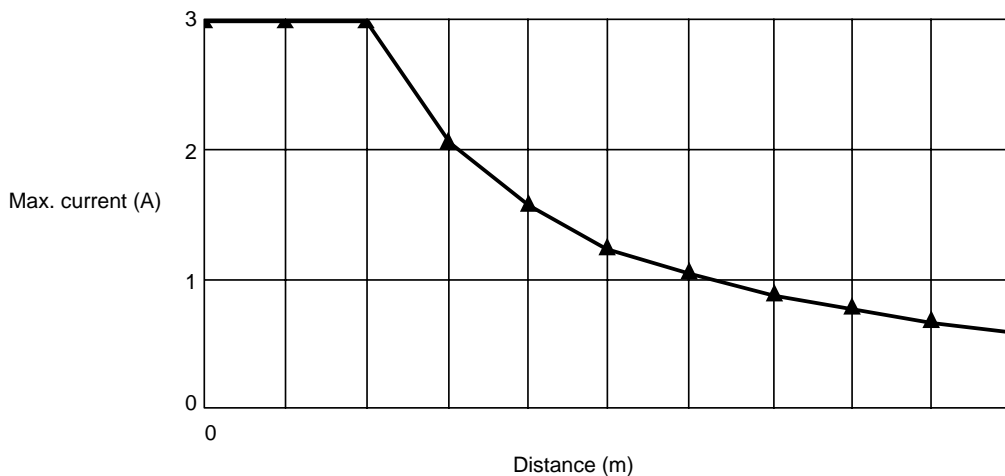

**Determining the Best Location of the Power Supply from a Graph**

Verify the Items 1. to 3. below for each node located in the same direction viewed from the power supply. Therefore, if nodes are located on both sides of the power supply, these items must be verified for all nodes located in each direction.

- 1, 2, 3...**
1. Find A, the total current consumption of all the nodes to which communications power is to be supplied.
  2. Using the graph compute B, the maximum current flow in each cable from the power supply to the end of the trunk line according to the types of cables (thick or thin).
  3. Compare the values found in steps 1. and 2., above. If the first value (A) is less than the second (B), this shows that power supply specifications are met and power can be supplied to all nodes at any point in the network.

**Note** Be sure to refer to the correct graph because the maximum current flow is different for thick and thin cables.

**Countermeasures**

If the second value (B) is less than the first (A), use the following procedure to locate the communications power supply.

- Locate the communications power supply in the center of the network and the nodes to both sides of it.



- If the nodes are already located at both sides of the power supply, move the power supply in the direction that requires the larger current capacity.
- If thin cable is being used, replace it with thick cable.

If, after following the above procedure, B is still less than A, go to Step 2 and determine the actual position of the nodes by the formula calculation method.

**Example: Uneven Current Consumption on Left and Right**

The following example shows a Network that requires power to be supplied for 240 m on thick cable. The power supply must be located off the center of the Network. Because the current consumption is not the same on the left and right sides of the Network, the current flow to one side will be insufficient if the power supply is connected in the very center of the Network. Placing it off center just a little allows power to be supplied to all nodes.

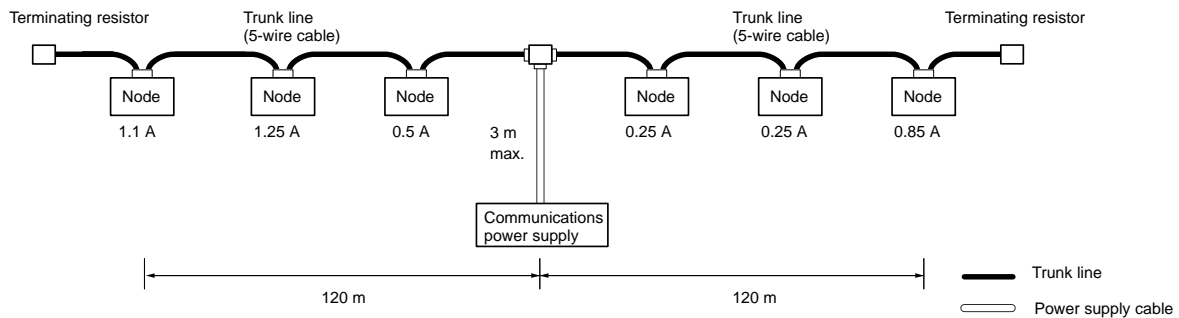

Total power supply length on left = Total power supply length on right = 120 m  
 Total current consumption on left:  $1.1 + 1.25 + 0.5 = 2.85 \text{ A}$   
 Total current consumption on right:  $0.25 + 0.25 + 0.85 = 1.35 \text{ A}$   
 Maximum current for thick cable for 120 m (see previous table) = approx. 2.5 A (using straight line approximation between 100 to 150 m)

Because the total current flow on the left side (2.85 A) is greater than the maximum current on the left side (2.56 A), the power supply cannot be placed at the center of the network and supply current to all nodes.

This problem can be corrected by moving the communications power supply as shown in the following diagram.

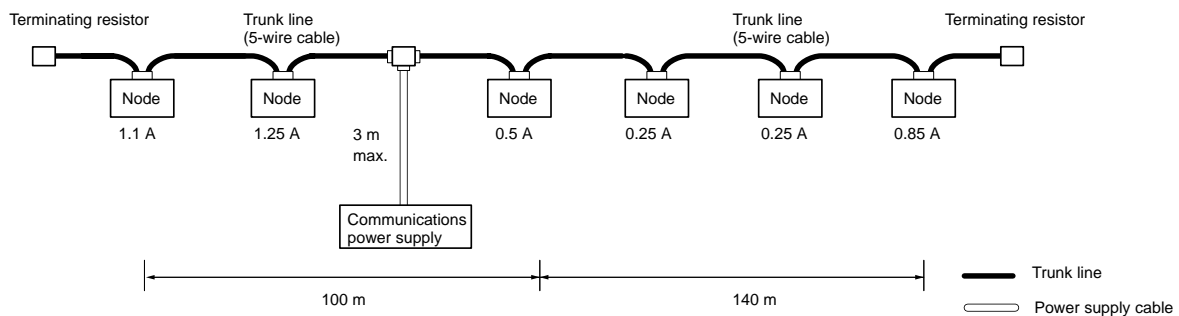

Total power supply length on left = 100 m  
 Total power supply length on right = 140 m  
 Total current consumption on left:  $1.1 + 1.25 = 2.35 \text{ A}$   
 Total current consumption on right:  $0.5 + 0.25 + 0.25 + 0.85 = 1.85 \text{ A}$   
 Maximum current for thick cable for 100 m (see previous table) = 2.93 A  
 Maximum current for thick cable for 140 m (see previous table) = 2.1 A (using straight line approximation between 100 to 150 m)

Because the total current flow on both the left and right sides is now less than the maximum current, the power supply can be placed as shown in the diagram and supply current to all nodes.

### 3-3-5 Step 2: Calculating the Best Location of the Actual Nodes

Go to Step 2 if the best location for the power supply cannot be determined from the graphs. The second method calculates the best location for each actual node and does not estimate the worst possible configuration for the power supply.

Basically, in the DeviceNet network the permissible maximum voltage drop within the system can be specified at 5 V for a power supply line (+V or -V), by calculating the specifications for the voltage of the communications power supply (24 VDC) and the input voltage of the communications power supply of each device (11 to 25 VDC).

Of the permissible maximum voltage drop within the system (5 V), the permissible voltage drop in the trunk lines and drop lines are 4.65 V and 0.35 V respectively.

#### Voltage Drop

In the DeviceNet network the voltage drop at the communications cables, taking the allowance into consideration, is 5 V or less, according to the specifications for the communications power supply device (24 VDC) and communications power supply for each node (11 to 25 VDC).

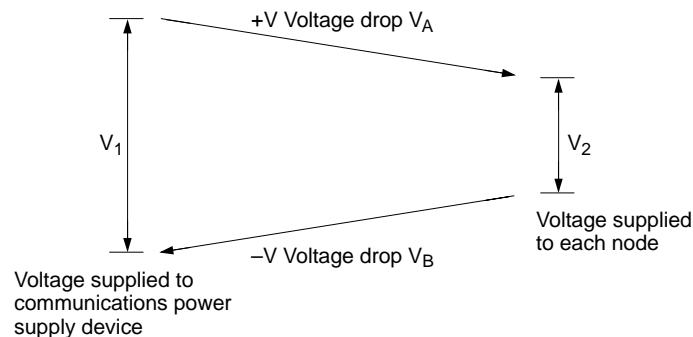

$V_1$ : Voltage supplied to the communications power supply device. Consider the ambient variations of the power supply voltage and take  $V_1$  to be 23 V.

$V_2$ : Voltage supplied to each node. Consider the allowance and take  $V_2$  to be 13 V or greater.

$V_A$ : Voltage drop at the power supply cables (+V).

$V_B$ : Voltage drop at the power supply cables (-V).

In the DeviceNet network  $V_A$  and  $V_B$  is taken as 5 V or less.

The voltage drop at the communications cables is specified at 5 V for a single power supply line (+V or -V). Of the permissible maximum voltage drop within the system (5 V), the permissible voltage drops in the trunk lines and drop lines are 4.65 V and 0.35 V respectively.

**Note** Note that when the communications power supply for each node and the internal circuit power supply must be shared, the permissible ambient voltage of the internal circuit is lower than the permissible maximum ambient voltage of the communications power supply. Also, the maximum voltage drop for a single power supply line (+V or -V) must be taken as 1 V. Of the permissible maximum voltage drop for a single power supply line (1 V), the permissible voltage drop in the trunk lines and drop lines are 0.65 V and 0.35 V respectively.

#### Formulas

#### Supplying Power Independently for Communications and Internal Circuit

Calculate the distance between the power supply and each node, and the current consumption of each node's communications. (Refer to the *DeviceNet (CompoBus/D) Operation Manual (W267)*.) Try to calculate the best location for

each node using the formula below. If the best location for each node can be determined using the formula, the specifications for the power supply to each node can also be met. Do not exceed the maximum current capacity of the cable (Thick cable: 8 A and thin cable: 3 A).

**Condition Formula 1 (For the Voltage Drop of the Trunk Line)**

$$\square (L_n \times R_c = N_t \times 0.005) \times I_n \square 4.65 \text{ V}$$

**Ln:** The distance between the power supply and the nodes (not including the lengths of the drop lines)

**Rc:** Maximum cable resistance  
(Thick cable: 0.015  $\Omega$ /m, thin cable: 0.069  $\Omega$ /m)

**Nt:** The number of taps between each node and the power supply

**In:** The consumption current required for the communications power supply for each node

0.005  $\Omega$  = The contact resistance of the taps

**Supplying Shared Power for Communications and Internal Circuit**

The permissible ambient power supplies of the communications and the internal circuit are as shown below.

**Note** Make every effort to avoid sharing the communications power supply and the internal circuit power supply. (Refer to 3-7 *Sharing the Same Power Supply* for details.)

- Permissible ambient voltage of the communications power supply:  
11 to 25 VDC
- Permissible ambient voltage of the internal circuit power supply:  
24 VDC from +10% to -15%

The lowest permissible ambient voltage is 11 VDC for the communications power supply, whereas it is 21 VDC including the allowance for the internal circuit power supply. Due to this difference in lowest permissible ambient voltages, when the internal circuit power is supplied by the communications power supply, the permissible ambient voltage drop at is lower than if the power supplies were separate. When the output voltage ambient fluctuation of the communications power supply has a lower limit of 23 V, the permissible maximum voltage drop of a single power supply line is  $(23 \text{ V} - 21 \text{ V}) / 2 = 1 \text{ V}$ . Of the permissible maximum voltage drop of a single power supply line (1 V), the permissible maximum voltage drop of trunk lines and drop lines are 0.65 V and 0.35 V respectively.

Calculate the distance between the power supply and each node and the total current consumption of each node in the communications and the internal circuit. (Refer to the *DeviceNet (CompoBus/D) Operation Manual (W267)*.)

Try to calculate the best location for each node using the formula below. If the best location for each node can be determined using the formula, the specifications for the power supply to each node can also be met. Do not exceed the maximum current capacity of the cable (Thick cable: 8 A and thin cable: 3 A).

**Condition Formula 2 (For the Voltage Drop of the Trunk Line)**

$$\square [(L_n \times R_c = N_t \times 0.005) \times I_n] \square 0.65 \text{ V}$$

**Ln:** The distance between the power supply and the nodes (not including the lengths of the drop lines)

**Rc:** Maximum cable resistance  
(Thick cable: 0.015  $\Omega$ /m, thin cable: 0.069  $\Omega$ /m)

**Nt:** The number of taps between each node and the power supply

**In:** The consumption current required for the communications power supply and the internal circuit power supply for each node

0.005  $\Omega$  = The contact resistance of the taps

**Countermeasures**

If the best locations cannot be determined using either the first or second formulae, follow the procedure as shown below.

- Locate the communications power supply in the center of the network and the nodes to both sides of it.
- If the nodes are already located at both sides of the power supply, move the power supply in the direction that requires the larger current capacity.
- If thin cable is being used, replace it with thick cable.
- Move the highest current consumption node nearer the power supply.

If the best locations still cannot be determined using the first and second formulae even after carrying out the above procedure, a single power supply will not be sufficient. In that case, proceed to Step 3.

**Configuration Example**

Nodes Located at Both Sides of the Power Supply (Trunk Line: Thick cable, Drop Lines: Thin cables)

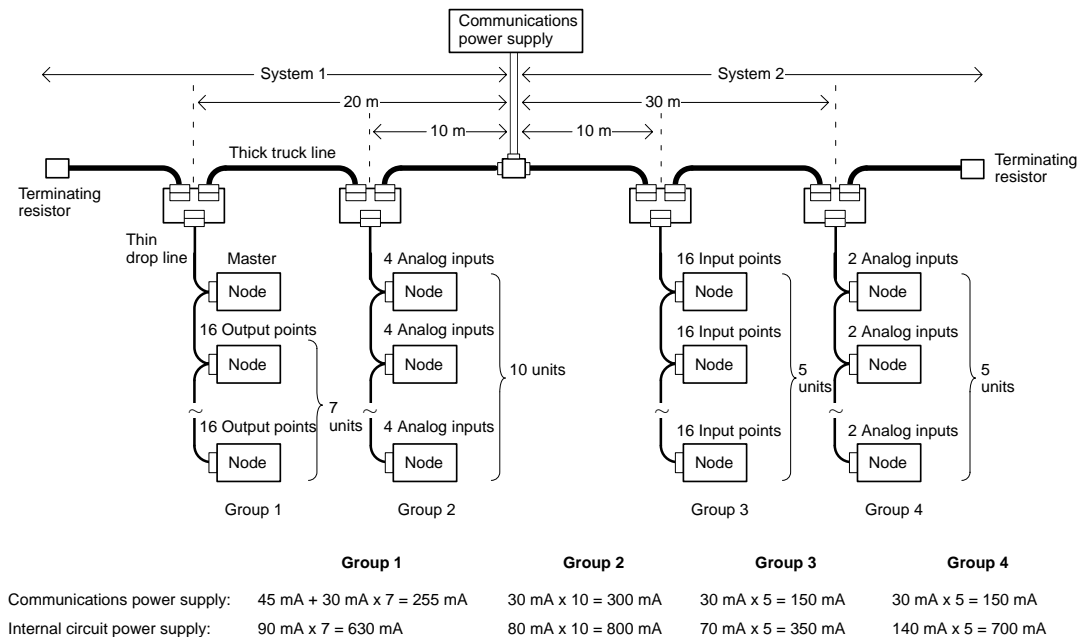

- Calculate the voltage drop of each group in each system when the network is supplied by the communications power supply only.

**System 1**

Group 1:  $(20 \times 0.015 + 2 \times 0.005) \times 0.255 = 0.0791 \text{ V}$

Group 2:  $(10 \times 0.015 + 1 \times 0.005) \times 0.3 = 0.0465 \text{ V}$

Total voltage drop for System 1 =  $0.0791 + 0.0465 = 0.1256 \text{ V} \approx 4.65 \text{ V}$

Thus, the best location for the nodes can be determined by using the first formula.

**System 2**

Group 3:  $(10 \times 0.015 + 1 \times 0.005) \times 0.15 = 0.0233 \text{ V}$

Group 4:  $(30 \times 0.015 + 2 \times 0.005) \times 0.15 = 0.069 \text{ V}$

Total voltage drop for System 2 =  $0.0233 + 0.069 = 0.0923 \text{ V} \approx 4.65 \text{ V}$

Thus, the best location for the nodes can be determined by using the first formula.

- Calculate the voltage drop of each group in each system when the communications and the internal circuit power supplies are the same.

**System 1**

Group 1:  $(20 \times 0.015 + 2 \times 0.005) \times 0.885 = 0.2744 \text{ V}$

Group 2:  $(10 \times 0.015 + 1 \times 0.005) \times 1.1 = 0.1705 \text{ V}$   
 Total voltage drop for System 1 =  $0.2744 + 0.1705 = 0.4449 \text{ V} \square 0.65 \text{ V}$   
 Thus, the best location for the nodes can be determined by using the second formula.

**System 2**

Group 3:  $(10 \times 0.015 + 1 \times 0.005) \times 0.5 = 0.0775 \text{ V}$   
 Group 4:  $(30 \times 0.015 + 2 \times 0.005) \times 0.85 = 0.391 \text{ V}$   
 Total voltage drop for System 2 =  $0.0775 + 0.391 = 0.4685 \text{ V} \square 0.65 \text{ V}$   
 Thus, the best location for the nodes can be determined by using the second formula.

**3-3-6 Step 3: Splitting the System into Multiple Power Supplies**

Go to Step 3 if the best location for the nodes cannot be calculated from the formulae. In the third step, there are multiple power supplies and the power supply system is split.

**Splitting the Power Supply System**

- Be sure to use a Power Supply Tap for each power supply when the network is supplied by two or more power supplies.
  - Remove the fuses in the Power Supply Tap to split the power supply system.
- Once the power supply system is split, return to Step 1 or 2, and determine the best location of the nodes in each system.

**Power Supply Tap Configuration**

Model	Name	Specifications	Manufacturer
DCN1-1P	Power Supply Branch Tap	Includes two connectors	OMRON
1485T-P2T5-T5	Power supply tap	Includes ground terminal	Allen-Bradley

**Power Supply Tap**

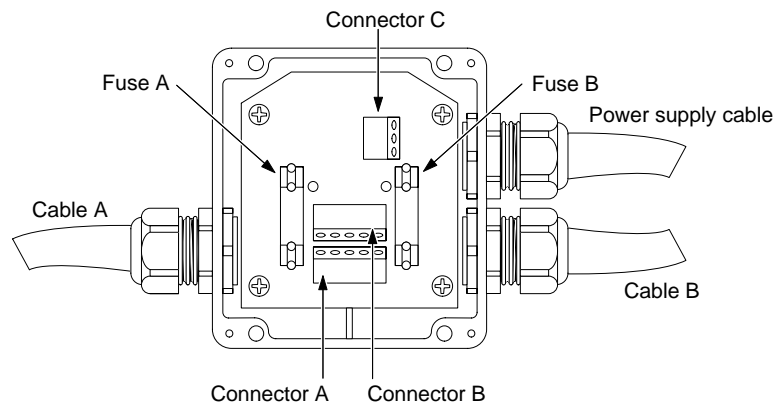

**Internal Circuitry of the Power Supply Tap**

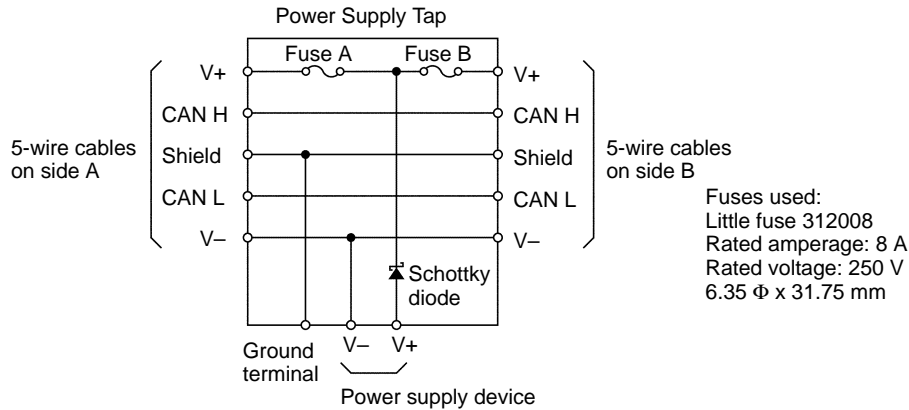

Remove fuse A when disconnecting cables on side A, and fuse B when disconnecting cables on side B.

**3-3-7 Dual Power Supply**

Power Supply Taps can be used to construct a dual power supply system in the network. Dual power supply differs from parallel operation of power supplies, so the following restrictions apply.

**Restrictions**

Dual power supply is basically used to ensure backup power supply, not parallel operation of power supplies. Therefore, each power supply to be used must meet the power allocation specifications (must satisfy steps 1 and 2).

**3-4 Grounding the Network**

The DeviceNet network is grounded only one point to prevent ground loops. Also, connect the ground as close as possible to the center of the network.

Connect the cable shield to the ground terminal (FG) on the communications power supply and then connect to a ground of 100 Ω max., as shown in the following diagrams.

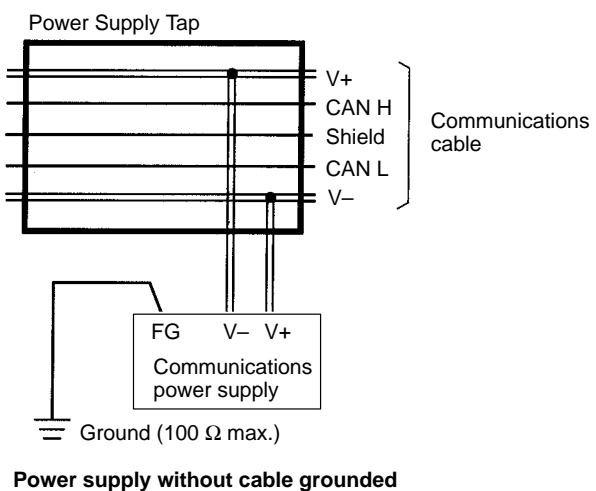
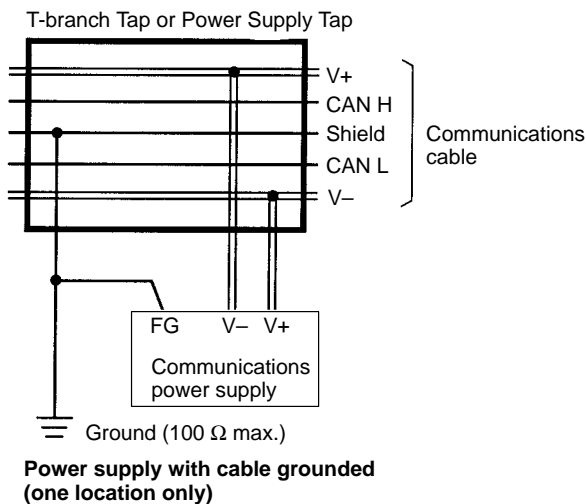

If more than one communications power supply is connected to the same network, ground only the one nearest the center of the network. Do not connect the shield wire at the other power supplies. Always use Power Supply Taps when connecting more than one communications power supply to the same network. (The power supplies are not counted as network nodes.)

**Note** 1. Always ground the communications cable shield at one and only one location in the network.

2. Always ground to 100 Ω or less.
3. Always use a separate ground. Never use the same ground as for inverters or other drive system devices.

### 3-4-1 Ground Wire Connection

#### Grounding from a Connector

The network can be grounded by inserting the ground wire into the same hole as the communications cable's shield wire, as shown in the following diagram.

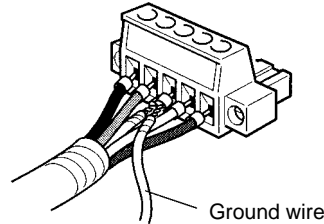

#### Grounding from a T-branch Tap

The network can be grounded by inserting the ground wire into one of the T-branch Tap connectors, as shown in the following diagram.

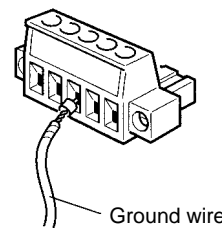

## 3-5 Noise Precautions

### General Precautions

To prevent inductive noise, do not wire the communications line, SYSMAC power lines and power lines near to each other. In particular, be sure to keep the power lines for inverters, motors, regulators, and contactors at least 300 mm away from both the communications lines and the SYSMAC power lines. Also, provide separate conduits or ducts for the communications lines and power lines.

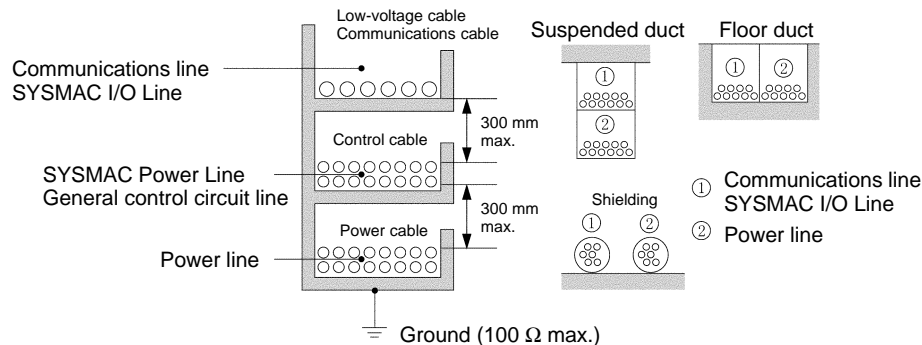

Do not install communications lines and SYSMAC Power Lines onto the control panel on which high-voltage devices are mounted.

Install surge suppressors on devices that generates noise, particularly devices that have an inductive component such as motors, transformers, solenoids, and magnetic coils.

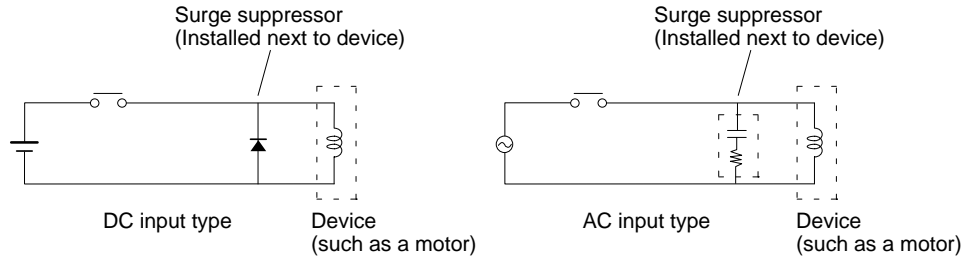

If a surge suppressor does not fit on the device, installing a ferrite core directly next to the device's contactors, such as a contactor may be effective.

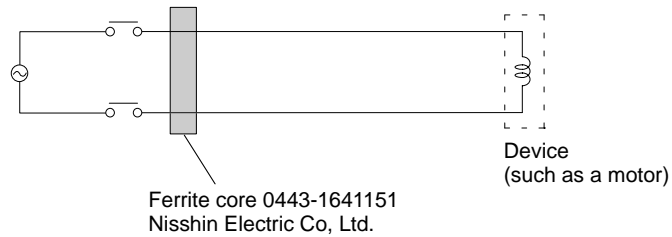

Because noise currents flow through metallic equipment (such as casings), the communications cables should be placed as far away from metallic equipment as possible.

Ground the shielding wire on the communications cable at one point. If the same ground is used for the communications cable and communications power supply, there is a possibility that noise may be transmitted through the ground line to the communications line. In order to avoid this, be sure that the power line ground and the grounds for the communications cables and the communications power supply are located as far from each other as possible.

Insert a line filter on the primary side of the communications power supply.

When there are two or more communications power supplies, the communications power cables can be grounded by simply connecting a single Power Supply Tap near the center of the communications cable. Do not ground shielding wire at more than one place.

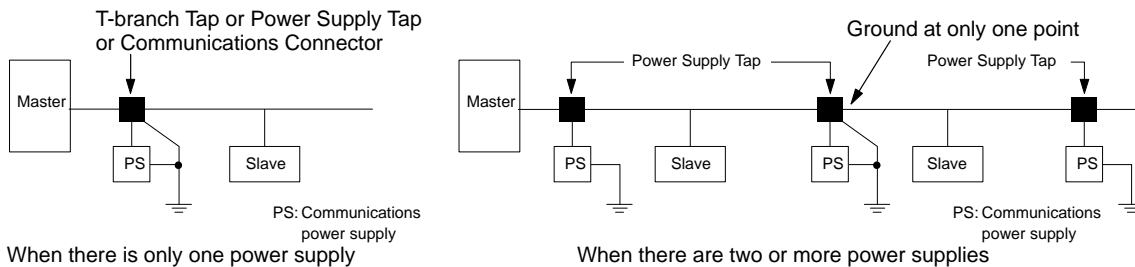



### 3-6 Correcting Faulty Operation Caused by Noise

When noise is thought to be the cause of a malfunction in the DeviceNet network, the following measures may be effective.

**Communications Cable Shielding**

Suspend the communications cable shielding wire without grounding it. This will filter the noise that flows from the ground to the communications cable and will filter the noise current that flows in the shielding wire.

**Communications Power Supply**

Suspend the communications power supply without grounding it. This will also filter the noise that flows from the communications power supply ground to the communications cable or the noise current that flows in the shielding wire. The switching power supply is usually connected to the case and the capacitor as shown below. The FG terminal must be suspended and the control board for the power supply itself must be insulated.

**Switching Power Supply Configuration**

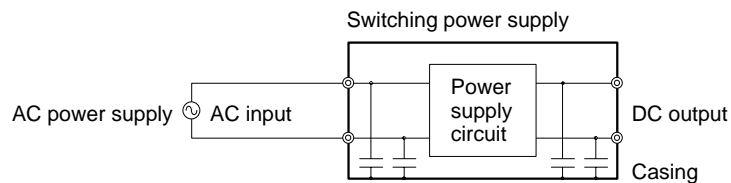

**Suspending the Communications Power Supply**

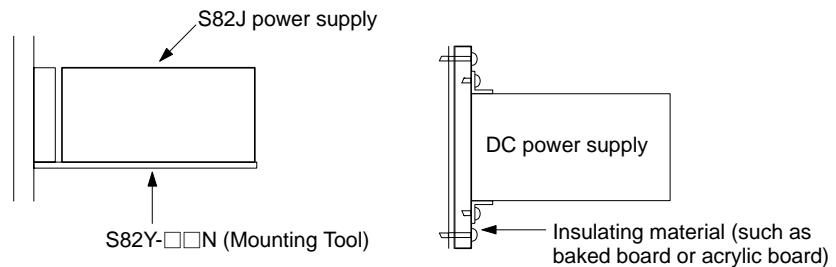

When using S82J power supply

When using other power supplies

### 3-7 Sharing the Same Power Supply

Slave Units in the DeviceNet network can be classified into three types according to how the power is supplied, as shown below. (The DeviceNet Interface Unit is the middle type.)

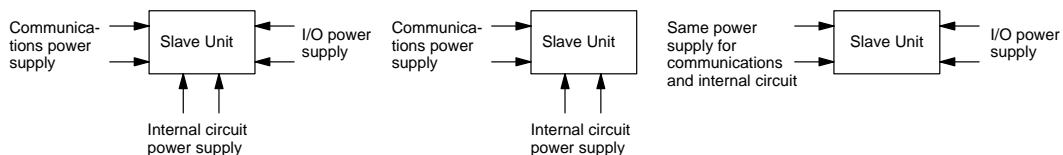

Because the power supplies for the communications, internal circuit and I/O are individually insulated as shown below, as a general rule each power supply should be connected separately.

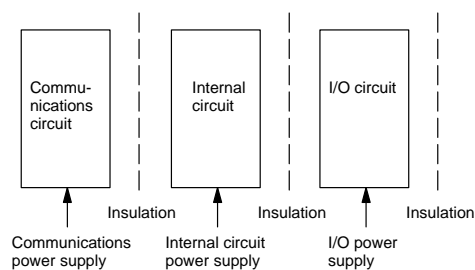

Because of space and cost difficulties involved in preparing individual power supplies, sharing the same power supply may be unavoidable. If this is the case, take the following precautions.

- Be sure to keep the I/O power supply separate.
- When the communications and internal circuit power supply is shared, wiring the network as shown in configuration A is recommended. Do not wire the network as shown in configuration B because it will generate more noise than the network in configuration A.

**Note** The lower voltage boundary of the internal circuit power supply must be higher than that of the communications power supply. To meet the voltage specifications for the internal circuit power supply, be sure to follow the specifications provided in 3-3 *Sharing the Communications Power Supply*.

Configuration A

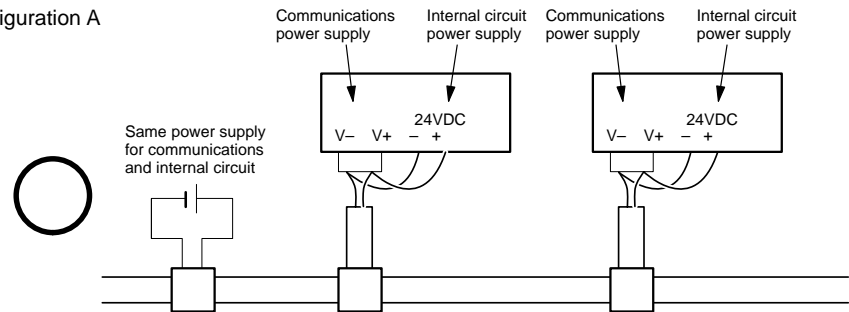

Configuration B

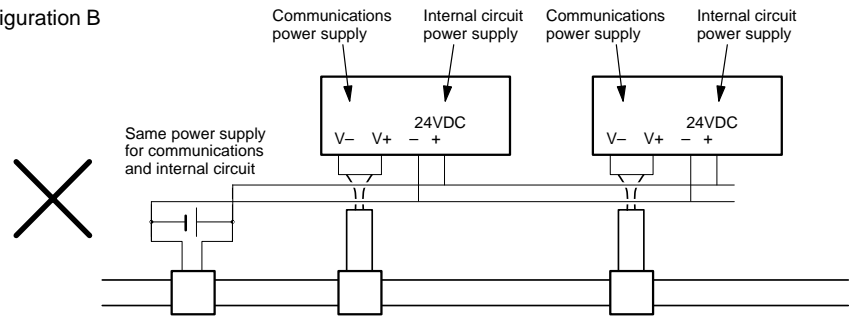

# SECTION 4

## Installation and Network Connection

This section explains how to mount the DeviceNet Interface Unit on the PT and connect the Unit to the DeviceNet network.

4-1	Components and Their Functions .....	44
4-2	Mounting the Unit on the PT .....	45
4-3	Connecting to the DeviceNet Network .....	45
4-3-1	Connecting Communications Cables .....	45
4-3-2	Installing and Removing the Connector .....	47
4-3-3	Connecting Communications Cables to T-branch Taps .....	48
4-3-4	Connecting Terminating Resistors .....	49

# 4-1 Components and Their Functions

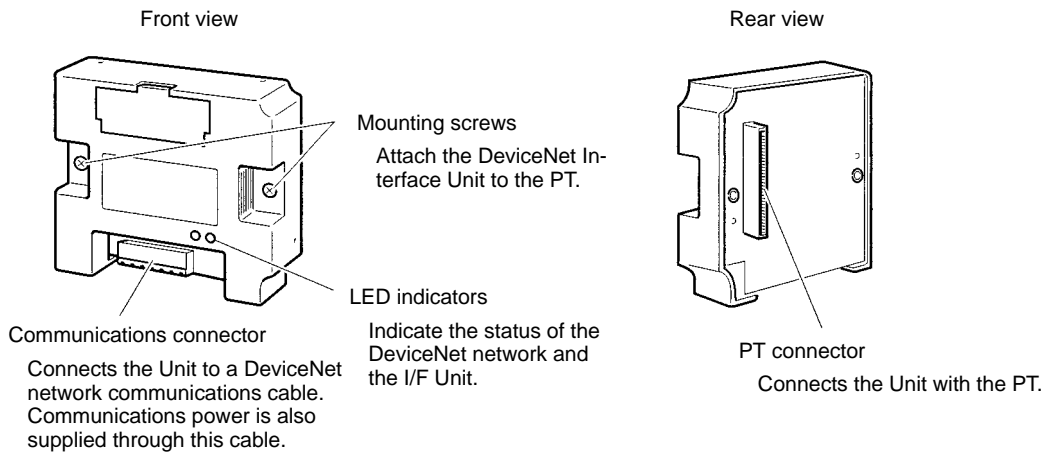

**Note** Inspect the DeviceNet Interface Unit for any damage after removing it from its packaging. Lightly shake the Unit to check whether any parts have broken off inside.

## LED Indicators

The following table shows the functions of the LED indicators. The color and status of the MS and NS indicators can be used to troubleshoot errors. Refer to 8-2 *Troubleshooting with the LED Indicators* for more details.

LED	Name	Color	Status	Indicated condition	Meaning
MS	Module status	Green	Lit	Normal status	Normal Unit condition
			Flashing	Not set yet	Switch settings are being read.
		Red	Lit	Fatal error	Unit hardware error (Watchdog Timer error)
			Flashing	Non-fatal error	Minor error such as incorrect switch settings
---	Not lit	No power being supplied	<ul style="list-style-type: none"> <li>Power is not being supplied to Slave Units.</li> <li>Waiting for initialization to start.</li> <li>Unit is being reset.</li> </ul>		
NS	Network status	Green	Lit	Online, communications established	Normal network condition (communications established)
			Flashing	Online, communications not established	Normal network condition but communications are not established
		Red	Lit	Fatal communications error	Communications error (The Unit detected an error which makes communications through the network impossible.) <ul style="list-style-type: none"> <li>Network power supply error</li> <li>Node number duplication</li> <li>Bus off detected</li> </ul>
			Flashing	Non-fatal communications error	Communications timeout
		---	Not lit	Offline or power supply OFF	<ul style="list-style-type: none"> <li>Waiting for completion of the Master's node number duplication check</li> <li>Incorrect switch settings (such as an incorrect baud rate setting)</li> <li>Faulty network communications cable</li> <li>Power supply OFF</li> </ul>

## 4-2 Mounting the Unit on the PT

Mount the DeviceNet Interface Unit to the Expansion Interface Connector on the back of the PT as shown in the following diagram. (The Expansion Interface Connector is under the “note” label.) This example shows an NT31/NT31C PT.

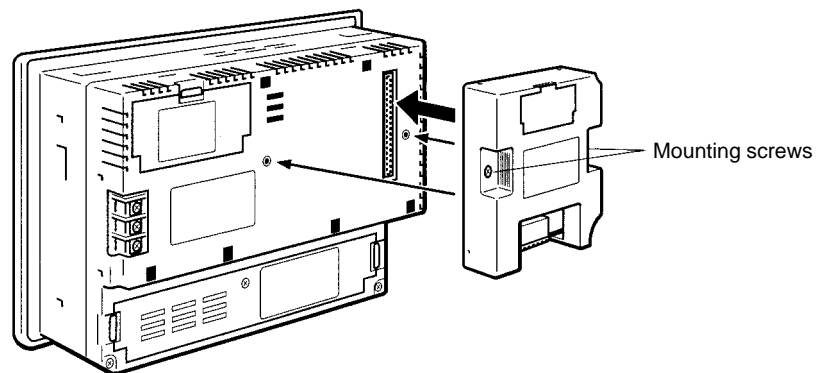

- Note**
1. Always turn OFF the PT before installing or removing the DeviceNet Interface Unit.
  2. Always tighten the two mounting screws after mounting the Unit on the PT.
  3. Do not touch the printed circuit board with your bare hands. Discharge the static electricity from your body before handling the board.

## 4-3 Connecting to the DeviceNet Network

This manual primarily explains how to connect the DeviceNet Interface Unit to a DeviceNet network. For details on connecting other Slaves or Masters, refer to the individual Unit's manuals.

### 4-3-1 Connecting Communications Cables

This section explains how to prepare and connect the communications cables to connectors for the DeviceNet network.

Use the following procedure to prepare and connect the communications cables to the connectors. Some connectors are equipped with set screws and some are not; only use connectors with set screws with the DeviceNet Interface Unit.

- 1, 2, 3...**
1. Remove approx. 30 to 80 mm of the cable covering, being careful not to damage the shield weaving underneath. Do not remove more than about 30 mm; removing too much of the covering can result in short circuits.

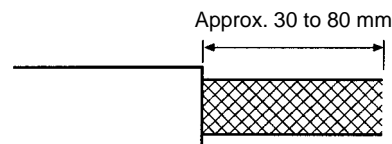

2. Carefully peel back the weaving. You'll find the signal lines, power lines, and the shielding wire. The shielding wire will be loose on the outside of the other lines, but it is harder than the weaving and should be easily identified.

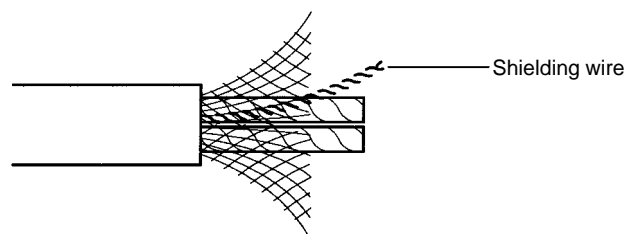

- Remove the exposed weaving, remove the aluminum tape from the signal and power lines, and strip the covering from the signal and power lines to the proper length for the crimp terminal connectors. Twist together the wires of each of the signal and power lines.

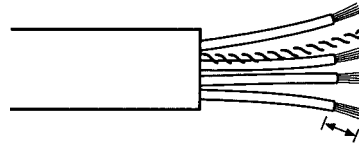

Strip to match the crimp terminals

**Note** We recommend the following crimp terminals for easier wiring and improved reliability.  
Phoenix Contact K.K., AI-series Crimp Terminals

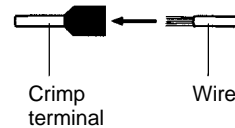

Insert the line into the terminal and then crimp.  
The following crimp tool is also available.  
Phoenix Contact K.K. Contact., ZA3 Crimp Tool

- Attach the crimp terminals to the lines and then cover any exposed areas of the cable and lines with electricians tape or heat-shrinking tubes.
- Orient the connector properly, loosen the line set screws, and then insert the lines in order from left to right: Black, blue, shield, white, and then red. The wiring method is the same regardless of whether or not the connector is equipped with set screws.

**Example: T-branch Connection**

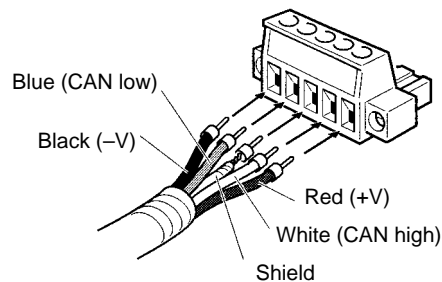

**Note** Be sure the wire set screws are sufficiently loosened before attempting to insert the lines. If these screws are not loose, the lines will enter the gaps in the back of the connector and will not lock properly.

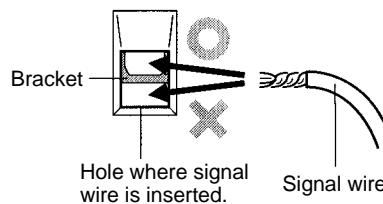

There are colored stickers provided on the Master Unit and Slaves that match the colors of the lines to be inserted. Be sure that the colors match when wiring the connectors. These colors are as follows:

Color	Signal
Black	Power line, negative voltage (-V)
Blue	Communications line, low (CAN low)
---	Shield
White	Communications line, high (CAN high)
Red	Power line, positive voltage (+V)

6. Tighten the line set screws for each line in the connector. Tighten the screws to a torque between 0.25 and 0.3 N·m.

You will not be able to tighten these screws with a normal screwdriver, which narrows to a point at the end. You will need a screwdriver that is consistently thin for the entire length.

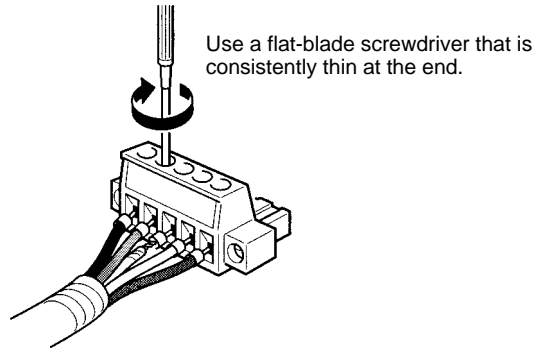

The following diagram shows the dimensions of the OMRON XW4Z-00C screwdriver which is made specifically for tightening these set screws.

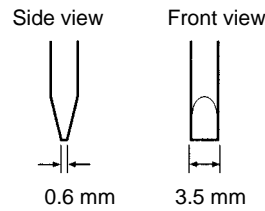

### 4-3-2 Installing and Removing the Connector

Align the cable connector with the Unit connector, insert the cable connector fully, and tighten the screws on both sides of the connector to lock it in place. Tighten the screws to 0.25 to 0.3 N·m.

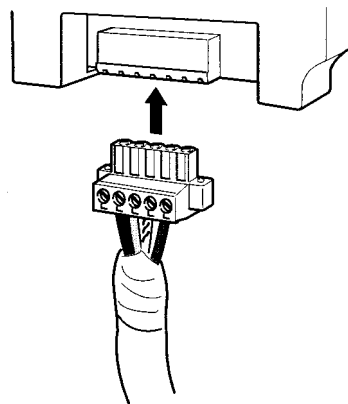

**Note** 1. Before connecting the communications cables, turn OFF the power supply to all PCs, Slaves, and communications power supplies.

2. Use crimp terminals for wiring. Connecting bare twisted wires can cause the cables to come OFF, break, or short circuit, most likely resulting in incorrect operation and possibly damage to the Units.
3. Use suitable crimp tools and crimping methods when attaching crimp terminals. Consult the manufacturer of the tools and terminals you are using. Inappropriate tools or methods can result in broken wires.
4. Be extremely careful to wire all signal lines, power lines, and shielding wire correctly.
5. Tighten all set screws firmly. Tighten to a torque of between 0.25 and 0.3 N□m.
6. Wire the signal lines, power lines, and shielding wire so that they do not become disconnected during communications.
7. Do not pull on communications cables with excessive force.
8. Allow leeway so that communications cables do not have to be bent further than natural. The Cables may become disconnected or wires may break if the cables are bent too far.
9. Never place heavy objects on communications cables.
10. Double-check all wiring before turning ON the power supply.

### 4-3-3 Connecting Communications Cables to T-branch Taps

This section shows how to connect a communications cable with a connector attached to a T-branch Tap. When using a DeviceNet Interface Unit, we recommend wiring with a T-branch Tap rather than the multi-drop method because it allows for easier maintenance.

There are two kinds of T-branch Taps, one makes a single branch and the other makes three branches, but the cable connections are the same for both.

The connectors indicated by asterisks in the following diagrams have the least resistance and these connectors should be used for the trunk line connections. When using a T-branch Tap on a drop line, we recommend connecting the longest drop line to these connectors.

**DCN1-1C (1 branch)**

\* Use for trunk line of longest drop line.

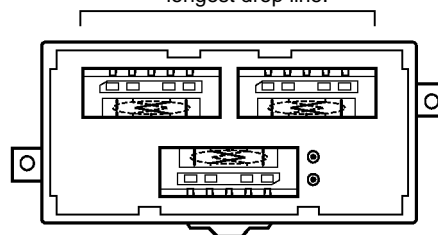

**DCN1-3C (3 branches)**

\* Use for trunk line of longest drop line.

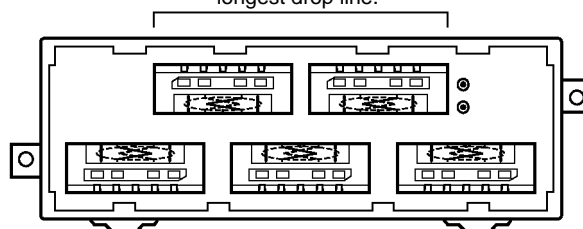

The required number of connectors is included with the T-branch Taps shown above. The following table describes the included connectors.



Model	Specifications	Manufacturer
XW4B-05C1-H1-D	Connector for T-branch Tap connection of a node (with connector attachment screws)	OMRON

Align the cable connector with the socket on the T-branch Tap as shown in the following diagram and fully insert the connector into the socket. Tighten the set screws to secure the connection. Tighten the screws to a torque of between 0.25 and 0.3 N·m.

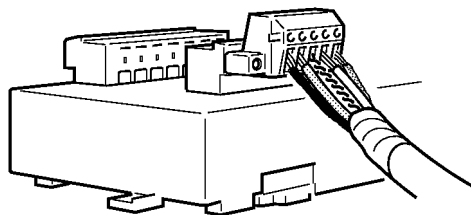

### 4-3-4 Connecting Terminating Resistors

Terminating Resistors must be connected at each end of the trunk line. This section shows how to connect the Terminating Resistors.

#### T-branch Tap Terminating Resistor

A terminating resistor is included with the T-branch Tap. Clip the leads on the resistor to about 3 mm and insert it into the T-branch Tap as shown in the following diagram. The resistor can face in either direction.

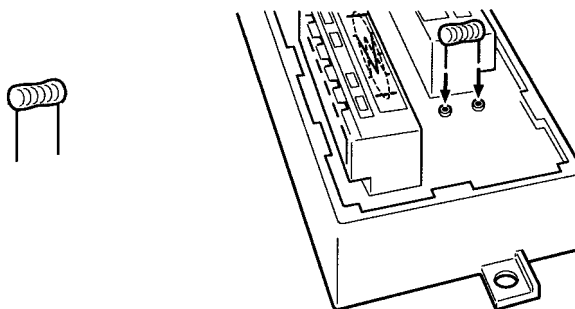

#### Terminal-block Terminating Resistor

A terminating resistor is built into the Terminal-block Terminating Resistor. To connect the cable to the Terminating Resistor, attach standard M3 crimp terminals to the signal wires and securely screw the terminals to the Terminal-block Terminating Resistor.

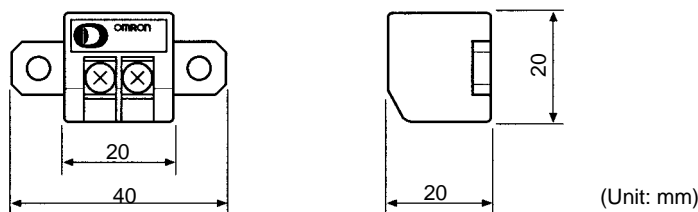

Tighten to a torque of 0.3 to 0.5 N·m.



**Note** To avoid damaging the cable or breaking wires, don't pull on the cable or bend it too sharply when connecting it to the terminal block. Also, never put heavy objects on top of the cable.

# SECTION 5

## PT Settings and Operations

This section explains the PT settings and operations required to use the DeviceNet Interface Unit.

5-1	Installing the System Program .....	52
5-1-1	PT Operations .....	52
5-1-2	Computer Operations .....	54
5-2	Structure of the System Menu .....	56
5-3	Initializing DeviceNet (CompoBus/D) Memory Switches .....	57
5-4	Serial Port A Settings .....	59
5-5	DeviceNet (CompoBus/D) Memory Switch Settings .....	61
5-6	Checking the PT Settings .....	64
5-7	Checking Communications with the PT .....	66
5-8	Checking the System Program Version .....	67

## 5-1 Installing the System Program

A special system program must be installed in the PT in order to use the DeviceNet Interface Unit. The system program for the DeviceNet (CompoBus/D) Interface Unit is included with the Unit.

This section explains how to install the system program in the PT. For details on other operations, refer to the PT's Setup Manual or the Support Tool's Operation Manual. (The NT-series Support Tool must be version 3.2 or higher.)

- Reference**
1. To install the system program, the system installer software is needed. The system installer is included with the NT-ZJ3AT1-EV3, ZJCAT1-EV3, and ZJCAT1-EV4 Support Tool. Install the system installer software when installing the Support Tool in your personal computer. Refer to the Support Tool's Operation Manual for details on installing and using the system installer software.
  2. The PT will be completely unusable if the system program is accidentally erased. Before deleting the system program, confirm that the Support Tool is equipped with the system installer software and there is a Memory Unit containing the system program. However, registered screen data and memory switch settings are retained.
  3. Install the system program for the PT being used (NT31, NT31C, NT631, or NT631C) that supports the DeviceNet Interface Unit.
  4. A PT which has the DeviceNet Interface Unit's system program installed can use only the functions of a -V1 version of the NT31/NT31C or NT631/NT631C PT. Only Memory Link communications can be used with the host. (The actual communications method is specific to the DeviceNet Interface Unit, but create screen data for the Memory Link method in the Support Tool.)
  5. The computer and PT must be connected in order to transfer the system program from the computer to the PT. For details, refer to the PT's Setup Manual or the Support Tool's Operation Manual.

### 5-1-1 PT Operations

To prepare for the system program download, put the PT in system installer mode and delete the system program from the PT. An NT31/NT31C PT is used in these examples, but the steps are the same for an NT631/NT631C.

- Reference** It isn't possible to download the system program with the DeviceNet Interface Unit installed. Before downloading the system program for the DeviceNet Interface Unit, remove the DeviceNet Interface Unit from the PT. (The PT must be OFF when removing the DeviceNet Interface Unit.)

#### Putting the PT into System Installer Mode

When installing the system program, either turn ON or reset the PT while pressing the touch switch (7.2 mm square) in the upper-left corner of the PT screen.

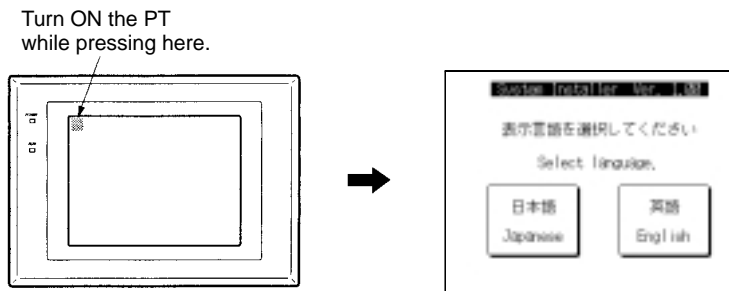

**Caution** Do not turn OFF or reset the PT while data is being transferred.

**Reference** The PT will enter system installer mode automatically when the power is turned ON if the PT does not contain a system program or contains a corrupted system program.

### Setting the Display Language

In system installer mode, the first screen sets the display language to English or Japanese. Set the display language to English when using the DeviceNet Interface Unit.



Press *English*.



The system installer mode's menu will be displayed. When the system program is missing or corrupted, the message *System program not exist or incorrect* will be displayed.

### Erasing the System Program

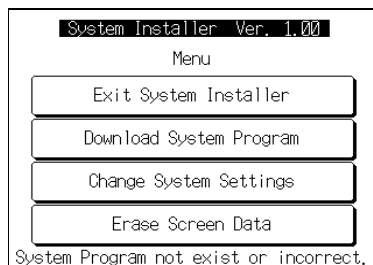

Press *Download System Program*.



Press *Yes*.

The system program will be erased. A message will be displayed while the system program is being erased.

- If *Return to Menu* is pressed, the PT will return to the system installer mode's menu without erasing the system program.
- If the erase operation failed, a screen will be displayed that asks whether or not to erase the system program again.

When the erase operation is completed, the PT will be ready for the system program to be downloaded.

### Downloading the System Program

If the system program was erased properly, the PT will automatically wait for the system program to be downloaded.



When the PT is in this status, transfer the system program from the computer's system installer.

The PT will track the system program transfer as the program is being downloaded.

If the **Abort** button is pressed while the PT is downloading or waiting for the download, the download will be cancelled and a screen will be displayed that asks whether or not to download the system program again.

## 5-1-2 Computer Operations

Start the *NT-series System Installer* in the personal computer and transfer the system program to the PT.

### Extracting the System Program

Extract the system program for the DeviceNet Interface Unit from the floppy disk that is included with the Unit.

The system programs are in compressed, self-extracting files in two floppy disks. One disk contains the NT31/NT31C system program (Nt31.exe) and the other contains the NT631/NT631C system program (Nt631.exe).

Self-extracting file	Contents	Remarks
Nt31.exe	DRT-E0A.31	System program for the NT31
	DRT-E0A.31c	System program for the NT31C
Nt631.exe	DRT-E0A.631	System program for the NT631
	DRT-E0A.63c	System program for the NT631C

The compressed files are self-extracting, so the contents can be extracted just by double-clicking the file name and specifying the destination directory.

### Starting the System Installer

1, 2, 3...

1. Start the system installer by selecting **Start/Programs/Omron/Ntst3.2e/NT-series System Installer** from the Windows **Start** Button. (The menu names in your system may be slightly different depending upon the Support Tool version and selections made when the Support Tool was installed.)
2. When the system installer has started, a main menu like the one below will be displayed.

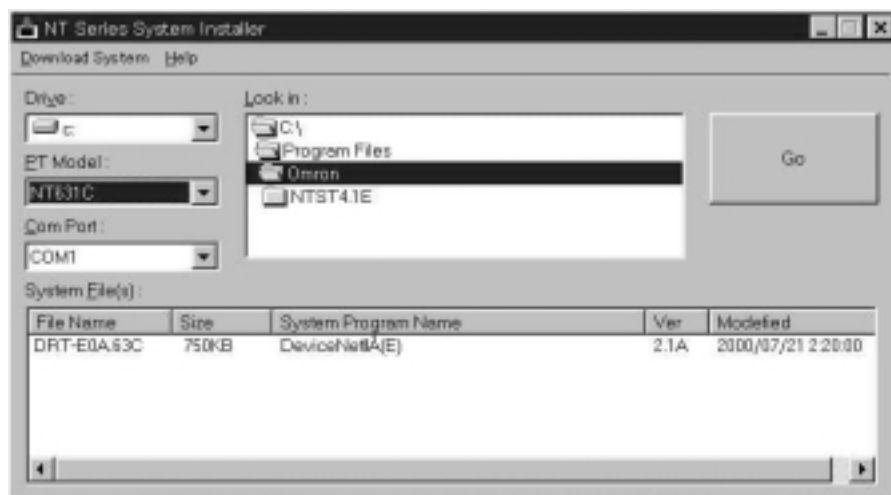

Any one of the following operations can be used to close the system installer.

- Select **Download System/Exit** from the menu.
- Click the **X** button in the upper-right corner of the main system installer window.
- Double-click the system installer icon in the upper-left corner of the system installer window.
- Click the system installer icon in the upper-left corner of the main system installer window and select **Close** from the menu.
- Press the **Alt** and **F4** Keys.

The computer will return to the Windows screen when the system installer closes.

**Installing the System Program**

Use the following procedure to install the system program.

- 1, 2, 3...**
1. Specify the *PT Model* of the PT in which the system will be installed. The *PT Model* field is in the main system installer window.
  2. Specify the *Drive*, *File Location (Look in)*, and *System File* of the system program to be installed. The selected items are displayed in reverse video.

The system programs for the specified PT Model family in the selected folder will be displayed in the *System Files* area. Specify the system program to be installed in the PT from this area.

The following table shows the system programs which support the Device-Net Interface Unit for each PT model.

File name	Corresponding PT model
DRT-E0A.31	NT31
DRT-E0A.31c	NT31C
DRT-E0A.631	NT631
DRT-E0A.63c	NT631C

3. Specify the RS-232C port (COM port) that will be used to communicate with the PT. The *COM port* field is in the main system installer window.
4. Click the **Go** button in the main system installer window.  
Installation of the system program will begin. The progress of the transfer will be tracked during the installation.
5. A message will be displayed when installation is completed. Check the message and click the **OK** button to confirm.

When installation of the system program is completed, the following display will appear at the PT allowing the PT to be restarted with the new system program.



Press *Run System*.

The PT will start regular operation when the system program is started. The system menu will be displayed if screen data has not been transferred.

**Reference** The PT will be completely unusable if the system program is not downloaded properly after the PT's system program is erased. Always download the system program completely after the system program is erased.

## 5-2 Structure of the System Menu

The System Menu allows the various functions of the PT to be executed using touch switches displayed as a menu on the touch panel. The structure of the system menu (menu tree) is shown below. The difference between the system program for the DeviceNet Interface Unit and the standard system program is also shown.

The menu shown here is from an NT31/NT31C PT. The menu items may differ slightly depending upon the PT model being used, but the items related to the DeviceNet Interface Unit are the same for all PT models.

This manual explains only the operations that are changed or edited for use with the DeviceNet Interface Unit. Refer to the PT's User's Manual for details on all other operations.

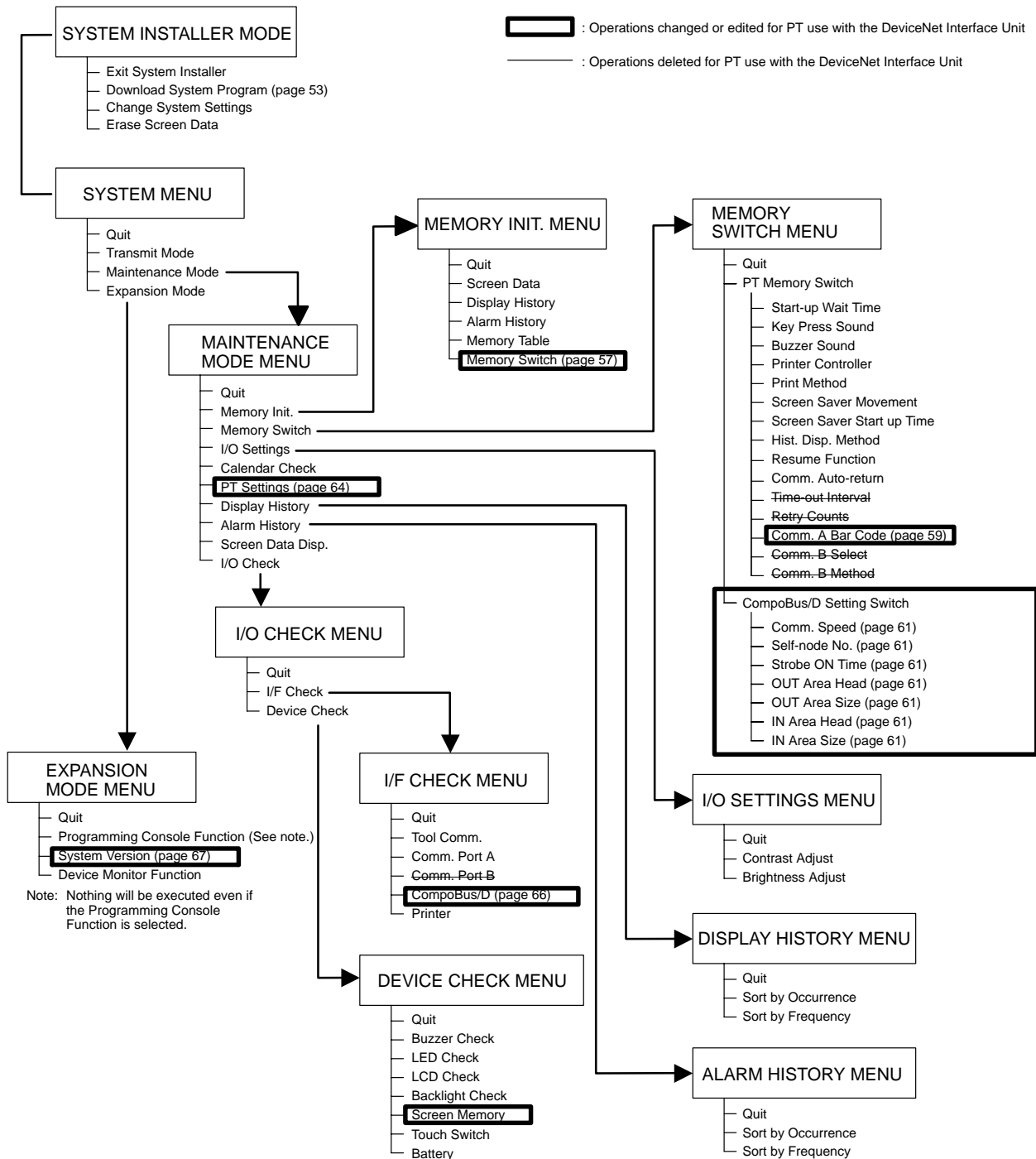

## 5-3 Initializing DeviceNet (CompoBus/D) Memory Switches

In addition to the standard OMRON memory initialization functions, the system menu for the DeviceNet Interface Unit has a function that initializes CompoBus/D setting switches.

Refer to the PT's User's Manual for details on the other memory initialization operations.

- Reference**
1. Memory initialization cannot be performed when screen memory is write-protected with the system installer mode's system settings.
  2. Either PT memory switches or CompoBus/D setting switches can be selected from the memory switch initialization menu. Select PT memory switches to initialize settings other than those for the DeviceNet Interface Unit.
  3. When the CompoBus/D setting switches have been initialized, the DeviceNet Interface Unit will use 32 input words and 32 output words. The number of words used by all of the Slaves (including the DeviceNet Interface Unit) must not exceed the maximum number of words available in the Master. In particular when the Master is a C200HS, a DeviceNet Interface Unit set to its default settings will use all of the Master's available words.

If the number of words used by all of the Slaves exceeds the maximum number of words available in the Master, either reduce the number of Slaves or reduce the number of words used by the DeviceNet Interface Unit by changing the settings of the CompoBus/D setting switches.

The memory switches for the DeviceNet Interface Unit that have been set in the PT will all be returned to their factory-default settings by the CompoBus/D setting switch initialization function.

Use the following operation in the system menu to initialize all of the memory switch settings.

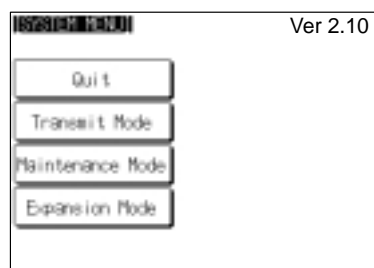

Press **Maintenance Mode**.

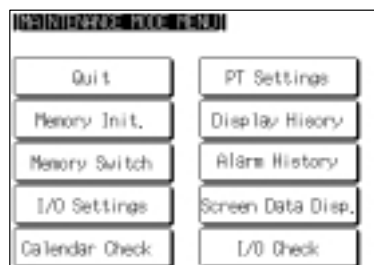

Press **Memory Init.**







Press **Memory Switch**.

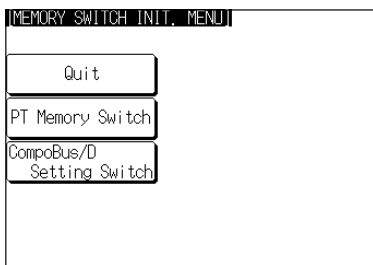

Press **CompoBus/D Setting Switch**.

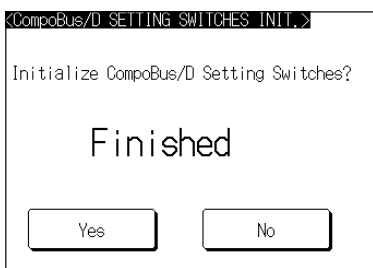

Press **Yes**.  
 The memory switches for the DeviceNet Interface Unit will be initialized. The message *Initializing* will be displayed while initialization is in progress.  
 When initialization is completed, a message will be displayed and then the reset screen will be displayed.

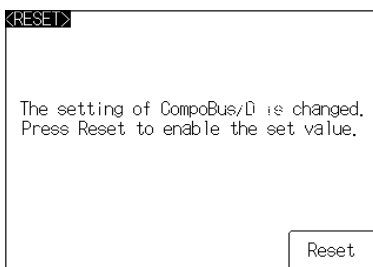

Press **Reset**.  
 The PT will be reset and will restart.

If **No** is pressed in the CompoBus/D setting switch initialization screen, the switch settings will not be initialized and the PT will return to the Memory Init. menu.

The following table shows the default settings that will be set when the CompoBus/D setting switches are initialized.

Item	Meaning	Setting
Comm. speed	Communications speed	125 kbps
Self-node No.	Local node number	63
Strobe ON Time	Strobe ON time	30
OUT Area Head	Output area starting address	PM0000
OUT Area Size	Output area size	32
IN Area Head	Input area starting address	PM0032
IN Area Size	Input area size	32

## 5-4 Serial Port A Settings

When the DeviceNet Interface Unit is used, the PT is connected to the host through the DeviceNet Interface Unit. That is why the PT cannot communicate with the host through serial ports A and B. Serial port A can be used only for a bar code reader and serial port B cannot be used at all.

The NT31/NT31C and NT631/NT631C are equipped with a bar code reader input function that allows character string data to be input from a bar code reader into character string input fields. This section explains how to set the communications conditions for communications with the bar code reader and the input data confirmation method.

- Reference**
1. When a bar code reader is connected to serial port A, character string data can be input from a bar code reader into character string input fields. The bar code reader type, connection method, communications settings, and operation are all the same as they are with standard OMRON system programs. This manual does not provide details on these subjects. Refer to the PT's Setup Manual for details.
  2. Either PT memory switches or CompoBus/D setting switches can be selected from the memory switch menu. The PT memory switches are the same memory switch settings found in the standard system programs. The CompoBus/D setting switches are the settings for the DeviceNet Interface Unit.
  3. The system menu for the DeviceNet Interface Unit does not contain settings for serial port B, so the PT memory switch setting requires only 3 screens.

Use the following operations from the system menu to set the communications conditions for communications with the bar code reader and the input data confirmation method.

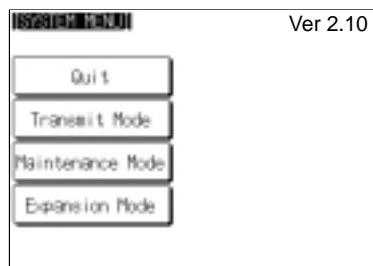

Press **Maintenance Mode**.

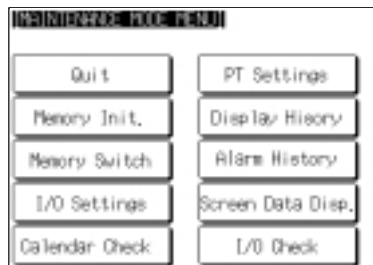

Press **Memory Switch**.



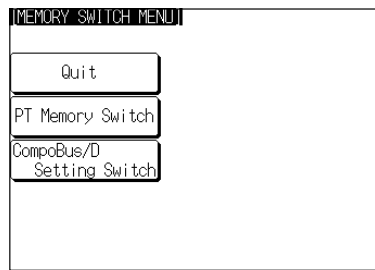

Press **PT Memory Switch**.

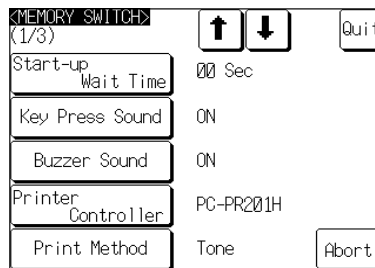

Press the **↓** touch switch (next screen) or **↑** touch switch (previous screen) to display the third memory switch setting screen.

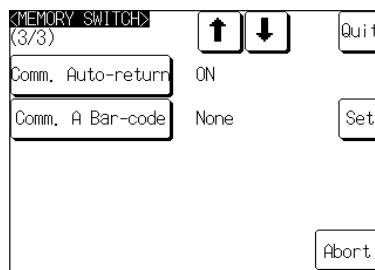

Press **Comm. A Bar-Code** and then select **ON** or **None**. The setting option changes each time that the touch switch is pressed.

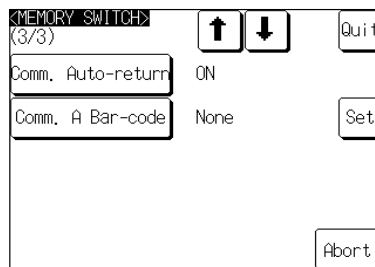

When connecting a bar code reader to serial port A, select **ON** and then press **Set**.

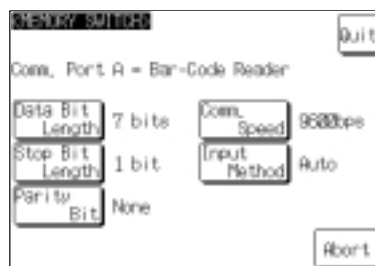

Display the required setting for each item by pressing the touch switches. The setting option changes each time the touch switch is pressed.



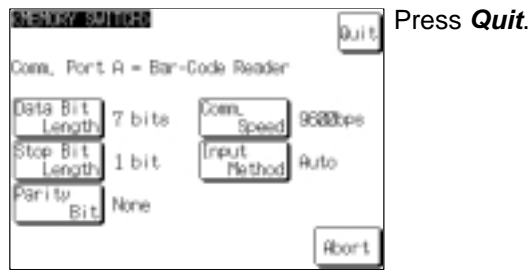

Pressing “Abort” on the communication condition/confirmation method setting screen causes the PT to return to the memory switch setting screen (3/3) without changing the settings. (The previous settings will still be effective).

When the communication condition/confirmation method settings have been completed, the PT returns to the memory switch setting screen (3/3).

To set other memory switches, select the relevant screen using the ↓ touch switch (next screen) or ↑ touch switch (previous screen) and then make the setting.

- To confirm the settings and quit the memory switch setting screen, press the **Quit** touch switch. The settings made last will be set and the PT will return to the memory switch menu.
- To quit the memory switch setting screen without confirming the settings, press the **Abort** touch switch. The PT will return to the memory switch menu screen with the previous settings still in effect.

## 5-5 DeviceNet (CompoBus/D) Memory Switch Settings

### Screen Layout and Settings

The 3 memory switch setting screens are shown in the following diagram.

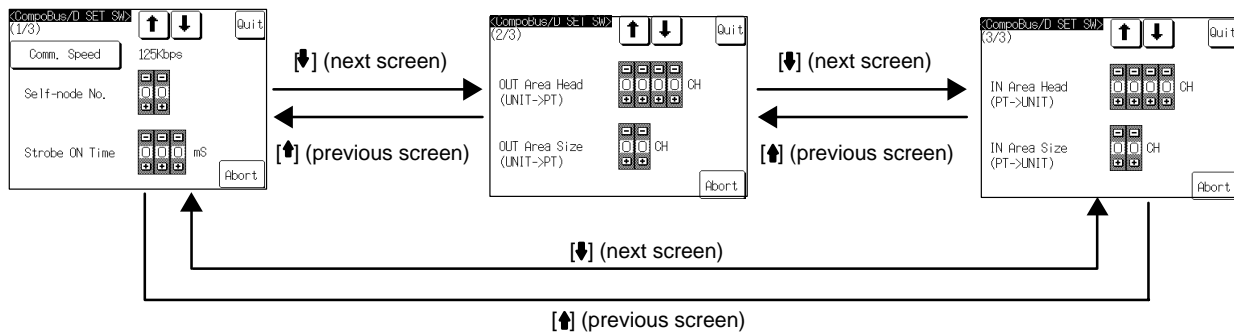

Make the following settings in the DeviceNet Interface Unit's system menu to use the PT as a Slave in DeviceNet remote I/O communications.

Item	Function	Settings	Default
Comm. Speed	Sets the speed used for communications with the DeviceNet Master.	125, 250, or 500 kbps	125 kbps
Self-node No.	Sets the PT's node number as a DeviceNet Slave.	0 to 63	63
Strobe ON Time	Sets the ON time of the strobes that indicate a change in the PT's status. The strobes include the screen change strobe, numeral input strobe, and character string input strobe. (The strobe ON time is set in ms.)	30 to 100 ms	30
OUT Area Head	Sets the leading address of the PT's output area allocated in PT memory when used as a DeviceNet Slave.	PM0000 to PM9999	PM0000
OUT Area Size	Sets the size of the PT's output area when used as a DeviceNet Slave. (The area size is set in words.)	0 to 32 words	32
IN Area Head	Sets the leading address of the PT's input area allocated in PT memory when used as a DeviceNet Slave.	PM0000 to PM9999	PM0032
IN Area Size	Sets the size of the PT's input area when used as a DeviceNet Slave. (The area size is set in words.)	0 to 32 words	32

This section only explains how to make these settings. For more details, refer to *6-1 Overview of Remote I/O Communications*.

**Note** Set all of the nodes in the DeviceNet network (Masters and Slaves) to the same communications speed. Setting a different communications speed in a Slave won't only disable communications with that Slave, it can also cause communications errors between nodes that are set to the correct communications speed.

- Reference**
1. If the node number setting is identical to the node number set on another node in the network, a node number duplication error will occur and the PT won't participate in network communications.
  2. Always set the strobe ON time longer than the instruction-execution cycle time of the PC in which the Master is mounted. If the strobe ON time is shorter than the Master PC's cycle time, the Master PC may not recognize the strobe signal.
  3. If possible, include the PT status notify area within the input area.
  4. If possible, include the PT status control area within the output area.
  5. The settings for the output area size and input area size determine the sizes of the PT's output area and input area when it is used as a Slave.

## Making Settings

Use the following operation in the system menu to set the CompoBus/D memory switches.

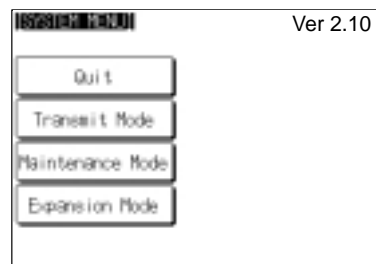

Press **Maintenance Mode**.



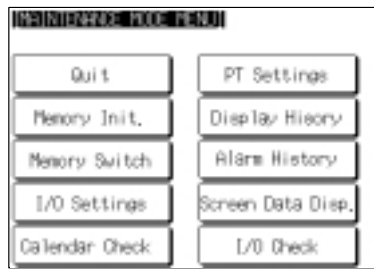

Press **Memory Switch**.

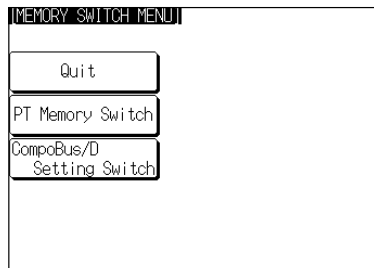

Press **CompoBus/D Setting Switch**.

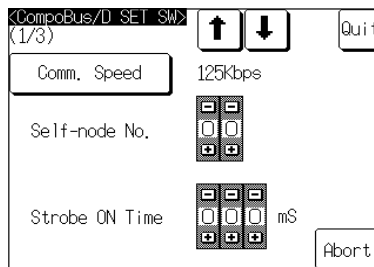

Press the **↓** touch switch (next screen) or **↑** touch switch (previous screen) to display the desired CompoBus/D switch setting screen. The current settings will be displayed when the desired screen is selected. The setting option changes each time the touch switch is pressed.

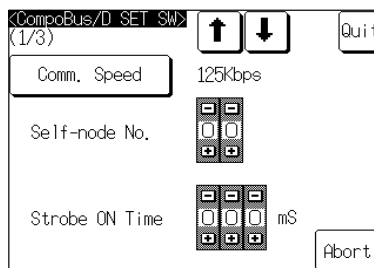

Press **Quit** when the CompoBus/D switch settings have been completed. The final settings will go into effect and the reset screen will be displayed.

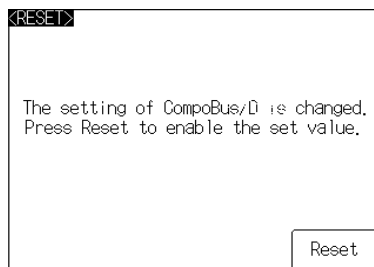

Press **Reset**. The PT will be reset and the PT will restart.

To set other memory switches, select the relevant screen using the **↓** touch switch (next screen) or **↑** touch switch (previous screen) and then make the setting.

To quit the CompoBus/D switch setting screen without confirming the settings, press the **Abort** touch switch. The PT will return to the memory switch menu screen with the previous settings still in effect.

## 5-6 Checking the PT Settings

This section explains how to check the settings for direct access of the PT's screen data, bar code reader settings for serial port A, and the DeviceNet Interface Unit's settings.

### Screen Layout and Settings

The 3 PT setting status screens are shown in the following diagram.

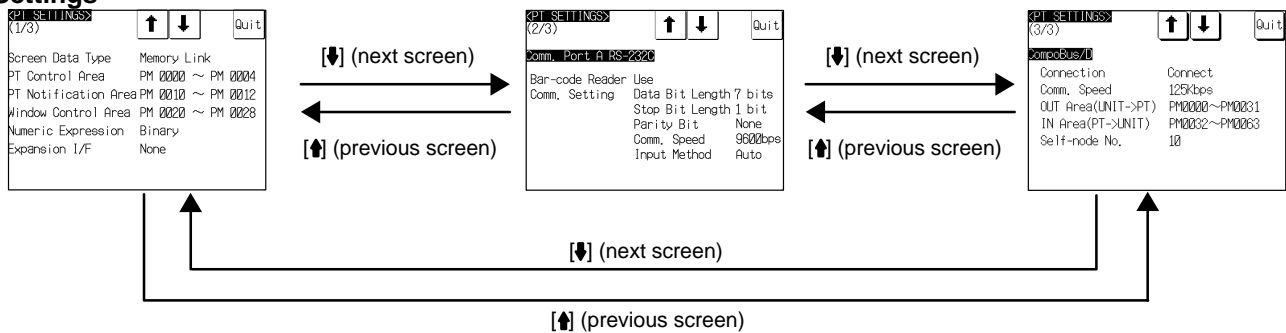

The third screen in the DeviceNet Interface Unit's system menu shows the CompoBus/D switch settings.

### Contents of Screen 1/3

It is possible to check the contents of the PT configuration settings set in screen data with the Support Tool. For details on Support Tool settings when using the DeviceNet Interface Unit, refer to *6-2 Settings with the NT-series Support Tool*.

Item	Meaning	Name in Support Tool
Screen Data Type	The PC model set for the screen data. (Always Memory Link)	<b>PLC Vendor in PT Type</b>
PT Control Area	Shows the words in the host (PT memory words) allocated to the PT status control area. PT memory is displayed as "PM."	<b>Control/Notify Area</b>
PT Notification Area	Shows the words in the host (PT memory words) allocated to the PT status notify area. PT memory is displayed as "PM."	
Window Control Area	Shows the words in the host (PT memory words) allocated to the window control area. PT memory is displayed as "PM."	
Numeric Expression	Shows the default format for the contents of words in the host that are allocated to numeral memory tables.	<b>Numeral Storage Type in System</b>

When the DeviceNet Interface Unit is used, the PT status control area contains 5 words, the PT status notify area contains 3 words, and the window control area contains 9 words. (In the standard OMRON configuration, the PT status notify area contains 2 words.)

The "Expansion I/F" setting is not displayed in the system menu for the DeviceNet Interface Unit.

### Contents of Screen 2/3

Item	Meaning
Bar Code Reader	Shows whether a bar code reader is used at serial port A.

**Contents of Screen 3/3**

Item	Meaning
Connection Status	Shows whether or not the DeviceNet Interface Unit is installed.
Comm. Speed	Communications speed in the DeviceNet network
OUT Area	Shows the DeviceNet output area words allocated in PT memory.
IN Area	Shows the DeviceNet input area words allocated in PT memory.
Local Node No.	Shows the PT's node number as a DeviceNet Slave.

**Displaying Settings**

Use the following operation in the system menu to display the PT settings.

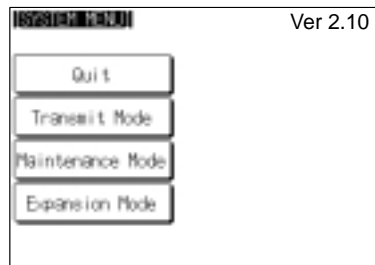

Press **Maintenance Mode**.

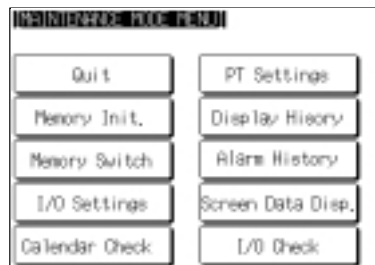

Press **PT Settings**.

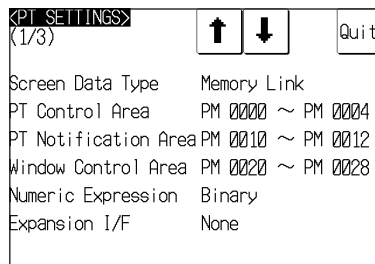

Press the ↓ touch switch (next screen) or ↑ touch switch (previous screen) to display the desired screen.

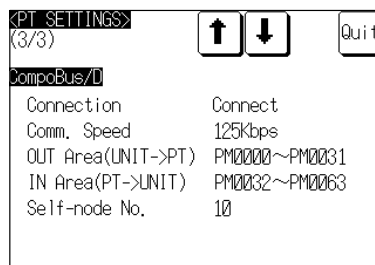

Press **Quit** to return to the maintenance mode menu.



## 5-7 Checking Communications with the PT

Use the following operation in the system menu to check communications between the PT and the DeviceNet Interface Unit.

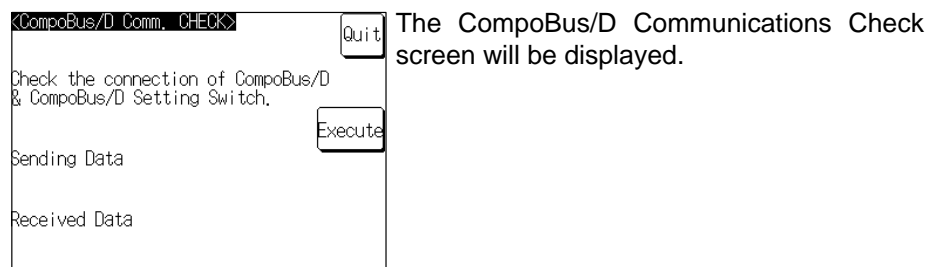
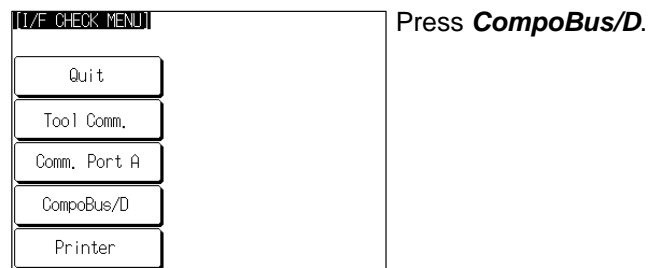
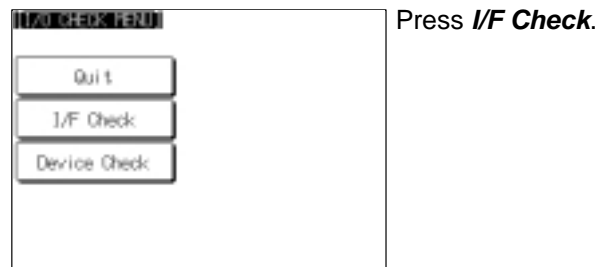
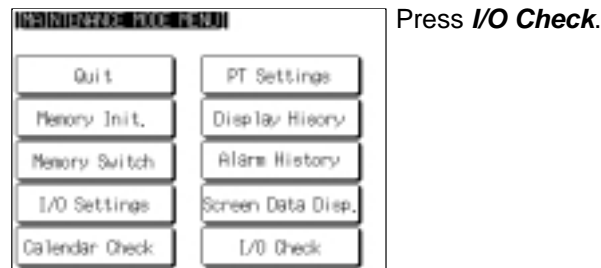
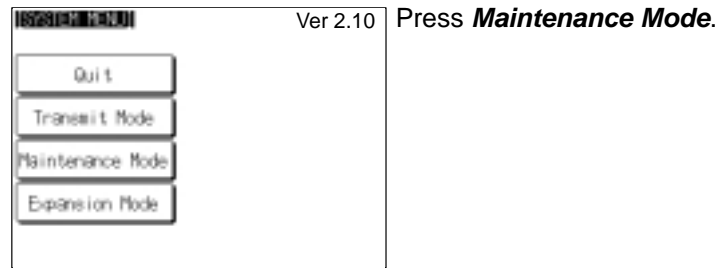

The communications check begins when **Execute** is pressed in the CompoBus/D Communications Check screen. The data string "01 02 04 08 10 20 40 80" is sent to the DeviceNet Interface Unit and displayed under *Sending Data*.

If communications with the Unit are normal, the same data "01 02 04 08 10 20 40 80" will be displayed under *Received Data*.

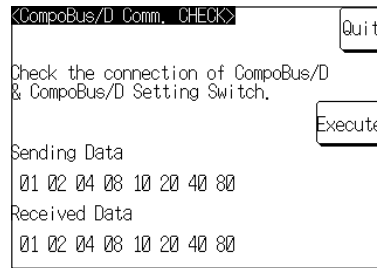

If an error occurs in communications with the Unit during the check, the correct data will not be displayed under *Received Data* or a communications error screen will be displayed. Check the PT's settings if a communications error occurs.

After checking the results of the communications check, press **Quit** to return to the I/F check menu.

## 5-8 Checking the System Program Version

The version of the system program installed in the PT can be displayed.

**Reference** Refer to 5-1 *Installing the System Program* for details on installing the system program that supports the DeviceNet Interface Unit.

Use the following operation in the system menu to display the PT system program's version information.

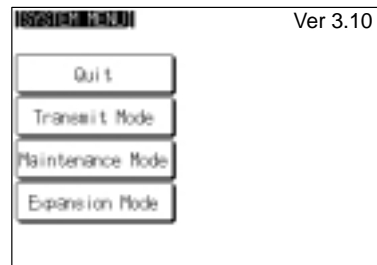

Press **Expansion Mode**.

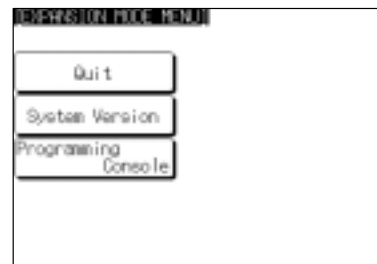

Press **System Version**.





The PT model, system program name, system program version, and creation date will be displayed.

After checking the system program information, press **Quit** to return to the expansion mode menu.

# SECTION 6

## Remote I/O Communications

This section shows how to use remote I/O communications with the DeviceNet Interface Unit and how to use the PT when using remote I/O communications.

6-1	Overview of Remote I/O Communications .....	70
6-1-1	Data Exchange with the DeviceNet Interface Unit .....	70
6-2	Settings with the NT-series Support Tool .....	72
6-2-1	Setting the PT Model and PC Model .....	72
6-2-2	Allocating Required Areas and Elements in PT Memory .....	72
6-2-3	Allocation Example .....	74
6-3	Allocating PT Memory to the Host (Master) .....	74
6-3-1	Allocating Input and Output Areas to PT Memory .....	74
6-3-2	Allocating Input and Output Areas to the Master .....	76
6-4	Allocating PT Data to PT Memory .....	81
6-4-1	Precautions when Allocating Data to PT Memory .....	81

## 6-1 Overview of Remote I/O Communications

The Master and Slaves can communicate as described below with DeviceNet remote I/O communications.

- Input Area:  
Inputs at the Slave are read automatically and mirrored in the Master's input area.
- Output Area:  
Data written in the output area allocated in the Master's memory are automatically output to the corresponding Slave.

**Reference** The names of the input and output areas indicate the direction of I/O from the perspective of the Master (host).

### 6-1-1 Data Exchange with the DeviceNet Interface Unit

The DeviceNet Interface Unit using remote I/O communications can exchange data with the host to control the PT or check its status.

The three allocation settings listed below must be made in order to perform remote I/O communications between the Master (PC) and PT using the DeviceNet Interface Unit.

- 1, 2, 3...**
1. The settings that allocate PT data (the PT status control/notify areas, window control area, or other elements) to PT memory

Allocated data		Allocation method
PT status control area, PT status notify area, and window control area		Set the Control/Notify Area in the NT-series Support Tool's PT Configuration settings.
Other elements	Numerical, character string, and bit memory table data	Set in the NT-series Support Tool's Table settings.
	Lamps and touch switches	Set in each element's properties with the NT-series Support Tool.

The allocation settings above are the same as they are with a regular PT set for Memory Link method.

2. The settings that allocate the DeviceNet Interface Unit's input and output areas in PT memory within the PT  
Set the input and output areas with the CompoBus/D setting switches in the PT's system menu. (Other DeviceNet memory switch settings are also required. Refer to 5-5 *DeviceNet Memory Switch Settings* for details.)
3. The settings that allocate the DeviceNet Interface Unit's input and output areas in the I/O memory of the Master (PC) (Free allocation or fixed allocation can be used.)

Set the input and output areas with the DeviceNet Master Unit's software switches or the Configurator.

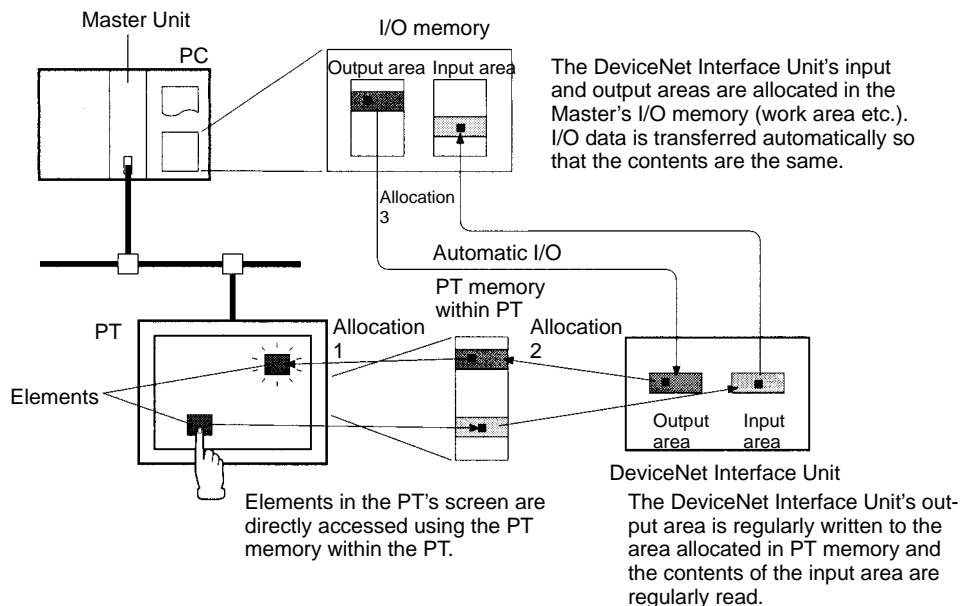

**Reading PT Status (Input Area Operations)**

- 1, 2, 3...**
1. If changes are made to the status or memory tables by PT or other operations, the changes are mirrored in PT memory.
  2. If there are changes in PT memory, the contents are automatically mirrored in the corresponding input area.
  3. The contents of the DeviceNet Interface Unit's input area are mirrored in the part of the host's input area that is allocated to the DeviceNet Interface Unit.
  4. The changes in PT status or memory tables can be read from the contents of the host's input area.

**Controlling the PT (Output Area Operations)**

- 1, 2, 3...**
1. Write data in the part of the host's output area that is allocated to the DeviceNet Interface Unit.
  2. Data written to the host's output area is automatically mirrored in the DeviceNet Interface Unit's output area.
  3. Data in the DeviceNet Interface Unit's output area is automatically written to the corresponding part of PT memory.
  4. The PT's display and operation change in accordance with the contents of PT memory.

**Precautions for the Strobe ON Time Setting**

The strobe ON time is the length of time that the PT keeps ON the signals which notify the host (Master) of a change in PT status. The strobe ON time setting controls all three strobes (the screen-switching strobe, numeral-input strobe, and character-string-input strobe.) Set the strobe ON time with the PT system menu's CompoBus/D setting switch.

Each strobe signal is turned OFF automatically after the strobe ON time elapses.

When setting the strobe ON time, be sure that it is longer than the cycle time in the host's CPU Unit so that the host (Master) will reliably read changes in the

strobe status. If the strobe ON time is shorter than the CPU Unit's cycle time, the Master may not read changes in the PT's status properly.

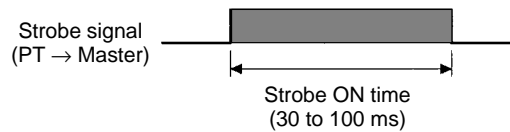

## 6-2 Settings with the NT-series Support Tool

This section explains the settings required at the Support Tool when using a PT with a DeviceNet Interface Unit installed. Refer to the PT's manuals for details on other settings required to use the PT. Refer to the Support Tool's Operation Manual for details on basic Support Tool operations.

### 6-2-1 Setting the PT Model and PC Model

The PT model and PC model must be set as follows at the PT to which the DeviceNet Interface Unit is installed.

PT Model:	For an NT31:	NT31-V1 (System Ver.2.1)
	For an NT31C:	NT31C-V1 (System Ver.2.1)
	For an NT631:	NT631-V1 (System Ver.2.1)
	For an NT631C:	NT631C-V1 (System Ver.2.1)

PC Model (PLC Vendor): MEMLINK (Memory Link)

Set the PT model and PC model (PLC Vendor) in the PT Type Tab of the Support Tool's PT Configuration Dialog.

### 6-2-2 Allocating Required Areas and Elements in PT Memory

In order to use the PT, the PT status control/notify areas, memory tables, and elements must be allocated in the host's area (called PT memory when using the Memory Link.)

When using the DeviceNet Interface Unit to communicate with the host (Master), it is necessary to plan the allocation of the input and output areas in PT memory at the same time that you decide on the allocation of the PT status control/notify areas, memory tables, and elements.

- Reference**
1. The input and output areas are regularly accessed from the host by remote I/O communications, so allocate areas and elements that are refreshed frequently. The input area is only read from the host and the output area is only written from the host.

Parts of PT memory outside of the input and output areas are accessed by explicit messages sent by the host, so it is best to allocate areas and data that aren't changed often. On the other hand, this area can be used for two-way read/write access from the host, so consider allocating parts of PT memory outside of the input and output areas to frequently refreshed data if two-way data transfer is required.

Refer to 6-3 *Allocating PT Memory to the Host (Master)* for details on allocating PT memory for the input and output areas.

2. Since the input and output areas are allocated in the PT's system menu, the allocation is not checked from the Support Tool. There is no check to prevent the output area that is written from the host from being allocated as an area that is written from the PT.

**Allocating Control/Notify Areas**

The following three control and notify areas must be allocated in PT memory in order for the PT to be used.

- PT status control area (5 words)
- PT status notify area (3 words)
- Window control area (9 words)

(It isn't necessary to allocate these words when the PT's window functions aren't being used.)

Allocate the control/notify areas in the Control/Notify Area Tab of the Support Tool's PT Configuration dialog. Set the leading PT memory address being allocated to each area in the PC address setting columns.

- Reference**
1. Data in the PT status control area and PT status notify area has to be exchanged frequently with the host (Master), so allocate these areas to the DeviceNet Interface Unit's output and input areas as shown below if at all possible.
    - PT status control area: In the DeviceNet Interface Unit's output area
    - PT status notify area: In the DeviceNet Interface Unit's input area
  2. When the DeviceNet Interface Unit is being used, the first word of the PT status notify area indicates the screen number of the screen currently being displayed at the PT. For this reason, the PT status notify area requires one word more than it does with the regular Memory Link.
  3. The control/notify area settings registered in the PT can be displayed with the PT Settings screen from the PT's system menu. Refer to 5-6 *Checking the PT Settings* for details.

**Allocating Data**

Allocate elements such as memory tables, lamps, or touch switches in PT memory when displaying the contents of host (Master) words on the PT screen or notifying the host (Master) of the results of PT operations.

Make allocation settings for numeral memory tables, character string memory tables, and bit memory tables with the Support Tool's Table screen. Make allocation settings for each element in each element's properties.

Data in the input and output areas is transferred in only one direction, so be sure to allocate data based on its usage, i.e., whether it is being transferred from PT → Host, Host → PT, or PT ↔ Host.

**Area/Data Type and Output/Input Area Allocation**

It is important to consider the direction of data flow (PT → Host, Host → PT, or PT ↔ Host) and number of words required when allocating the PT's control/notify areas, memory tables, and data such as elements to the output and input areas. Use the following table for reference.

Area or data type		Allocation size	Allocation to input or output area	
			Input area (PT → Host)	Output area (Host → PT)
PT status control area		5 words, fixed	×	△
PT status notify area		3 words, fixed	○	×
Window control area		9 words, fixed	△	△
Numeral memory table		1 or 2 words (See note 1.)	△	△
Character string memory table		1 to 20 words (See note 1.)	△	△
Bit memory table		1 bit	×	○
Lamp (lamp bit)		1 bit	×	○
Touch switch	Notification bit	1 bit	○	×
	Lamp bit	1 bit	×	○

○: Allocation OK

△: The functions are limited to the allocated area's transfer direction.

×: Allocation not possible



- Reference**
1. The number of words allocated to the memory tables can be set with the Support Tool.
  2. The output area and input area can be allocated up to 32 words of PT memory each. Refer to 6-3 *Allocating PT Memory to the Host (Master)* for details.

### 6-2-3 Allocation Example

Elements allocated in PT memory:

Element	Allocation
PT status control area	1 (Fixed at 5 words)
PT status notify area	1 (Fixed at 2 words)
Lamps	2
Touch switches (input notification function)	3
Numeral memory tables 0 to 3	4 (1 word each)

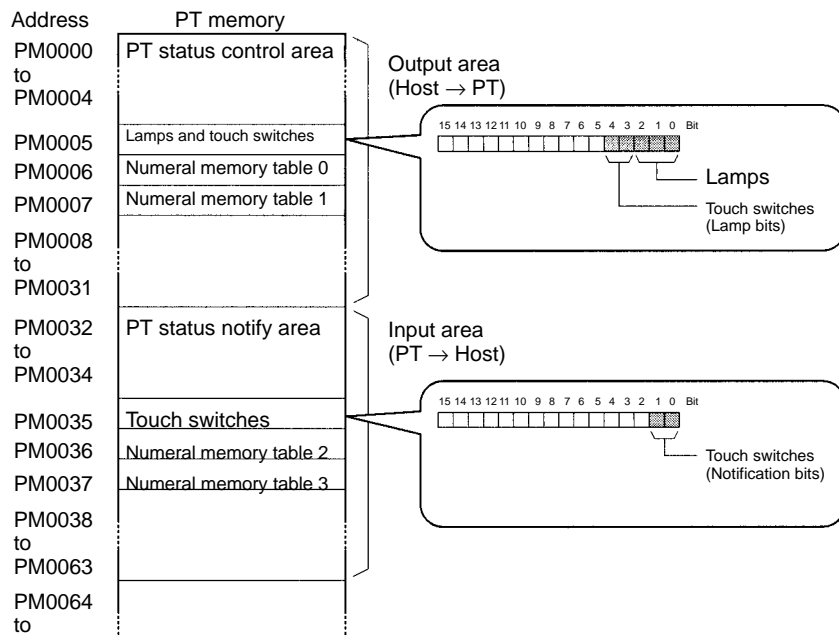

## 6-3 Allocating PT Memory to the Host (Master)

In order to use remote I/O communications with the DeviceNet Interface Unit, PT memory must be allocated in the host's DeviceNet I/O memory (input and output areas).

The following two steps are required to allocate PT memory in the host's input and output areas.

- Allocate the DeviceNet Interface Unit's input and output areas in the PT's internal PT memory. (Allocate memory with the PT's system menu.)
- Allocate the DeviceNet Interface Unit's input and output areas in the I/O memory of the PC (CPU Unit) where the Master is mounted. (Allocate memory to the Master as a DeviceNet Slave.)

The steps above indirectly allocate part of the PT memory's area to the host's (Master's) I/O memory as input and output areas.

### 6-3-1 Allocating Input and Output Areas to PT Memory

PT memory consists of 10,000 words from 0000 to 9999 (PM0000 to PM9999). The DeviceNet Interface Unit's input and output areas can be allocated to any location in PT memory and each area can be up to 32 words long.

Allocate input and output areas to PT memory from the PT's system menu by selecting **CompoBus/D Setting Switches**.

Item	Function	Setting range	Default
Output area leading address	Sets the leading PT memory address of the PT's output area when the PT is used as a DeviceNet Slave.	PM0000 to PM9999	PM0000
Output area size	Sets the size of the PT's output area when the PT is used as a DeviceNet Slave. (The area size is set in words.)	0 to 32 words	32
Input area leading address	Sets the leading PT memory address of the PT's input area when the PT is used as a DeviceNet Slave.	PM0000 to PM9999	PM0032
Input area size	Sets the size of the PT's input area when the PT is used as a DeviceNet Slave. (The area size is set in words.)	0 to 32 words	32

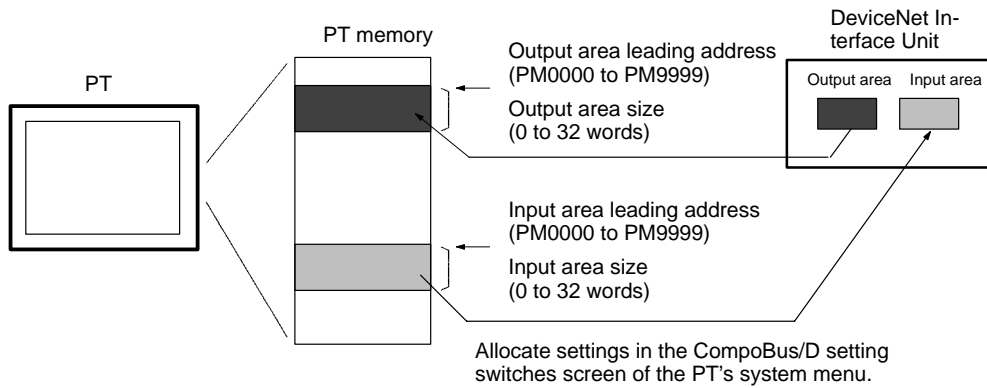

Refer to 5-5 *DeviceNet Memory Switch Settings* for details on making settings in the CompoBus/D setting switches screen of the PT's system menu.

**Reference** The output area settings are in the second page of the CompoBus/D setting switches screen and the input area settings are in the third page.

### 6-3-2 Allocating Input and Output Areas to the Master

The DeviceNet Interface Unit's input and output areas are allocated to the Unit as a DeviceNet Slave in the Master's I/O memory.

#### Fixed Allocation

With fixed allocation, words in the CPU Unit are allocated in the order of node numbers starting from node 00. The words are divided into an output area and an input area. The specific words that are allocated depend on the model of PC that is being used.

#### CVM1/CV-series PCs

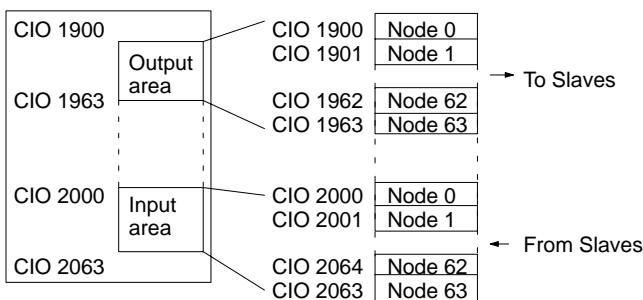

#### CS1-series PCs

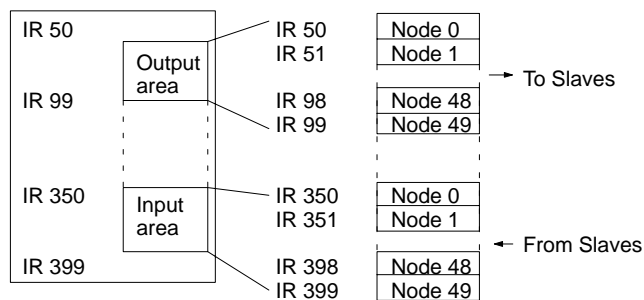

#### C200HX/HG/HE PCs

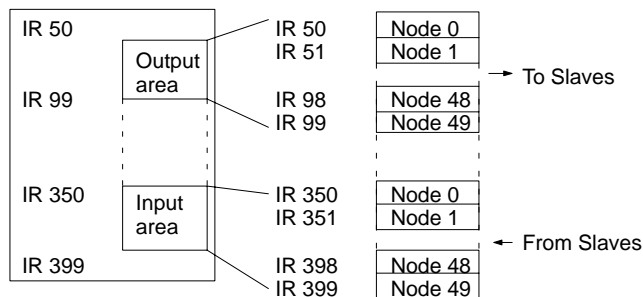

#### C200HS PCs

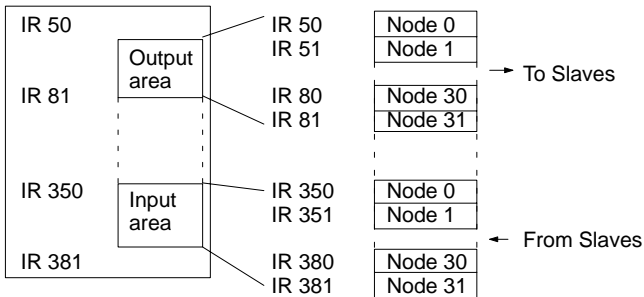

The DeviceNet Interface Unit will occupy the number of words (number of node numbers) set for the input and output areas in the DeviceNet memory switch screen. For example, when the Unit's input area size has been set to 16 words, the output area size has been set to 10 words, and the node number is set to 5, the input area will occupy the words for nodes 5 through 20 and the output area will occupy the words for nodes 5 through 14.

**Note** With the CS1 Series, the DeviceNet Output Area (CIO 0050 to CIO 0099) is contained inside the I/O Area (CIO 0000 to CIO 0319). For this reason, in systems with a large number of I/O points, edit the I/O table with the CX-programmer so that there is no overlap of area allocation.

Each node address is allocated one input and one output word. If a Slave requires more than one input or one output word, then it is assigned more than one node address. If a Slave requires less than one word, it simply uses the right-most bits in the word allocated to it.

**User-set (Free) Allocation**

A Configurator can be used to allocate a total of 4 blocks” blocks 1 and 2 in the output area and input blocks 1 and 2 in the input area in any order.

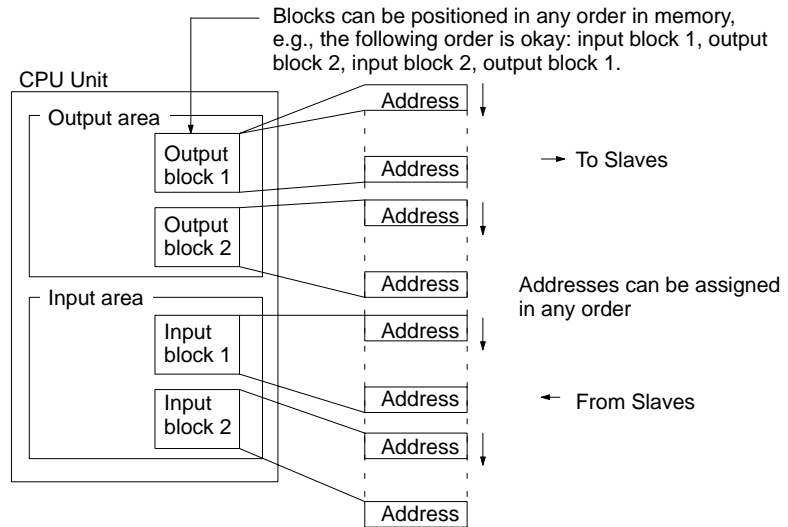

Slaves and blocks can be allocated in any order. The number of words (number of bytes) that are used depends upon the addresses. The minimum is one byte and the maximum is 64 bytes (32 words).

**Setting Example**

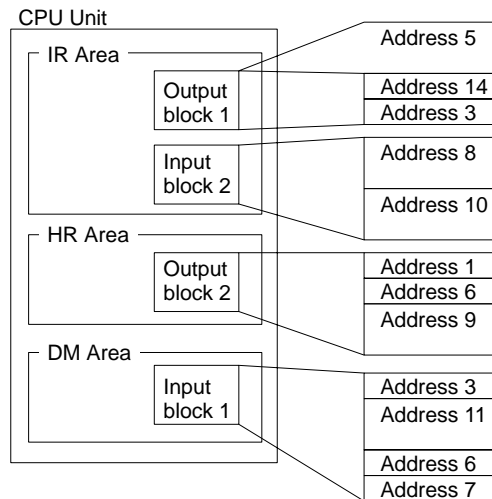

Data Areas for Remote I/O Communications

Item	Master model	Fixed Allocation (Without Configurator)	Free Allocation (With Configurator)
Maximum number of Slaves per Master	CVM1/CV-series	63 nodes	
	CS1-series, C200HX/HG/HE	50 nodes	63 nodes
	C200HS	32 nodes	63 nodes
Maximum number of controlled I/O points per Master	CVM1/CV-series	2,048 points (64 input words and 64 output words)	6,400 points (100 words × 4 blocks)
	CS1-series, C200HX/HG/HE	1,600 points (50 input words and 50 output words)	4,800 points (without messaging) 1,600 points (with messaging)
	C200HS	1,024 points (32 input words and 32 output words)	1,280 points
Maximum number of I/O points in Slave controlled by Master	CVM1/CV-series	32 input words and 32 output words	
	CS1-series, C200HX/HG/HE		
	C200HS		
Remote I/O allocation area	CVM1/CV-series	Input: CIO 2000 to CIO 2063 Output: CIO 1900 to CIO 1963	CV500/CVM1-CPU01 (-V□) CIO: 0000 to 2427 G: G008 to G255 DM: D00000 to D08191  Other PCs: CIO: 0000 to 2555 G: G008 to G255 DM: D00000 to D24575
	CS1-series, C200HX/HG/HE	CS1-series PCs: Input: CIO 0350 to CIO 0399 Output: CIO 0050 to CIO 0099  C200HX/HG/HE: Input: IR 350 to IR 399 Output: IR 50 to IR 99	CS1-series PCs CIO: 0000 to 0235, 0300 to 0511 HR: HR000 to HR099 CIO: 1000 to 1063 (see note) DM: D00000 to D05999  C200HE-CPU11(-Z) IR: 0000 to 0235, 0300 to 0511 HR: HR000 to HR099 LR: LR00 to LR63 DM: DM0000 to DM4095  Other C200HX/HG/HE PCs IR: 0000 to 0235, 0300 to 0511 HR: HR000 to HR099 LR: LR00 to LR63 DM: DM0000 to DM5999
	C200HS	Input: IR 350 to IR 381 Output: IR 50 to IR 81	IR: 0000 to 0235, 0300 to 0511 HR: HR000 to HR099 LR: LR00 to LR63 DM: D00000 to D05999

**Note** When LR 00 to LR 63 are allocated in CS1-series PCs with the Configurator, the actual words allocated are CIO 1000 to CIO 1063.

When free (user-set) allocation is used, up to 4 blocks (2 output blocks and 2 input blocks of up to 100 words each) can be set in the areas listed in the table above.

**Reference** There are limits on free allocation in CS1-series PCs. Follow the limits shown in the table above.

**Registering the Remote I/O Allocation Area**

This section explains how to connect the DeviceNet network properly.

**Reference** Only the basic connection procedures are explained here. Refer to the *DeviceNet (CompoBus/D) Operation Manual (W267)* for more details.

**Fixed Allocation**

The Master Unit's software settings for the following example procedure are shown below.

PC model	Leading word address
CVM1/CV-series	CIO 1500 + (25 × unit number)
CS1-series	CIO 2000 + (10 × unit number)
C200HX/HG/HE with unit numbers 0 to 9	IR 100 + (10 × unit number)
C200HX/HG/HE with unit numbers A to F	IR 400 + (10 × (unit number – 10))

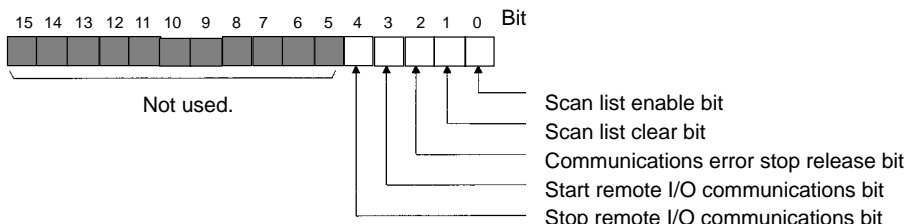

Use the following procedure to register the remote I/O allocation area.

- 1, 2, 3...
  1. Turn ON the Master (PC) after making any required Master Unit hardware settings. Refer to the *DeviceNet (CompoBus/D) Operation Manual (W267)* for details on Master Unit hardware settings.
  2. Connect a Programming Device to the PC, turn ON the Master (PC), and create the I/O table.
  3. Turn OFF the Master (PC).
  4. Turn ON all of the Slaves connected to the Master.  
 Make the required settings in the CompoBus/D memory switch screen of the PT connected to the CompoBus/D Interface Unit and reset the PT. Always set the input area size and output area size first.
  5. Turn ON the Master (PC).
  6. Switch the Master (PC) to PROGRAM mode.
  7. Check the Master's "Registered Slave information area" and verify that communications have been established with the connected Slaves. The location of the "Registered Slave information area" depends upon the PC being used as shown below.

PC model	Leading word address + 2
CVM1/CV-series	CIO 1502 + (25 × unit number)
CS1-series	CIO 2002 + (10 × unit number)
C200HX/HG/HE with unit numbers 0 to 9	IR 102 + (10 × unit number)
C200HX/HG/HE with unit numbers A to F	IR 402 + (10 × (unit number – 10))

	15	14	13	12	11	10	9	8	7	6	5	4	3	2	1	0
Leading address + 2	15	14	13	12	11	10	9	8	7	6	5	4	3	2	1	0
Leading address + 3	31	30	29	28	27	26	25	24	23	22	21	20	19	18	17	16
Leading address + 4	47	46	45	44	43	42	41	40	39	38	37	36	35	34	33	32
Leading address + 5	63	62	61	60	59	58	57	56	55	54	53	52	51	50	49	48

The numbers in the table above indicate the node numbers corresponding to each bit. A Slave is communicating normally when the bit corresponding to its node number is ON.

8. Use a PC Programming Device to turn bit 01 of the software switches (the scan list clear bit) from OFF to ON. (This operation is disabled when the Master is operating in scan list disabled mode.)

After a short time, turn the scan list clear bit OFF again. We recommend turning the bit OFF after verifying the results of the operation in the master status area.

9. Use a PC Programming Device to turn bit 00 of the software switches (the scan list enable bit) from OFF to ON.

After a short time, turn the scan list enable bit OFF again. We recommend turning the bit OFF after verifying the results of the operation in the master status area.

If the remote I/O allocation was registered properly and the Master is operating in scan list enabled mode, the dot display on the Master Unit's 7-segment LED will be OFF and remote I/O communications will start with the registered allocation.

Use a PC Programming Device to check whether remote I/O communications are operating as expected.

When the remote I/O allocation has been performed properly, remote I/O communications will start automatically the next time that the Master starts.

### **Free (User-set) Allocation**

Use the following procedure to register the remote I/O allocation area.

This example provides a summary of the relevant Configurator operations. Refer to the *DeviceNet (CompoBus/D) Configurator Operation Manual (W328)* for more details.

**Reference** This example explains the allocation when there is only one Master. Refer to the *DeviceNet (CompoBus/D) Operation Manual (W267)* for details on allocation with more than one Master.

- 1, 2, 3...**
  1. Turn ON the Master (PC) after making any required Master Unit hardware settings. Refer to the *DeviceNet (CompoBus/D) Operation Manual (W267)* for details on Master Unit hardware settings.
  2. Connect a Programming Device to the PC, turn ON the Master (PC), and create the I/O table.
  3. Turn OFF the Master (PC).
  4. Connect the Configurator to the DeviceNet network.
  5. Turn ON all of the Slaves.
 

Make the required settings in the DeviceNet memory switch screen of the PT connected to the DeviceNet Interface Unit and reset the PT. Always set the input area size and output area size first.
  6. Put the Configurator in online mode and read the network configuration.
  7. Create the Mater parameters. The Master parameters contain the input and output area settings and Slave I/O allocation. Always save the Master parameters in a file.
  8. Turn OFF all of the Slaves.
  9. Turn ON the Master (PC).
  10. Read the network configuration with the Configurator.
  11. Switch to the Master Unit's device parameters editing page in the Configurator, read the Master parameter file created in step 7., and write those Master parameters to the Master Unit.
  12. Turn ON all of the Slaves.
  13. Start remote I/O communications with the Configurator.

Use a PC Programming Device to check whether remote I/O communications are operating as expected.

When the remote I/O allocation has been performed properly, remote I/O communications will start automatically the next time that the Master starts.

If remote I/O communications are operating properly, we recommend reading the network configuration with the Configurator and saving that configuration as a file for future reference.

## 6-4 Allocating PT Data to PT Memory

The following data can be allocated in PT memory.

- PT status control area (5 words, fixed)
- PT status notify area (3 words, fixed)
- Window control area (9 words, fixed)
- Numeral memory table (1 or 2 words)
- Character string memory table (1 to 20 words)
- Bit memory table (1 bit)
- Lamp (1 bit)
- Touch switch (1 bit, and another bit for the host notification function)

- Reference**
1. The DeviceNet Interface Unit can be mounted to an NT31, NT31C, NT631, or NT631C PT. A PT with the DeviceNet Interface Unit's system program installed can use only the -V1 version functions of the PT.
  2. Refer to the *NT31/NT631 Programmable Terminal Reference Manual (V064)* for details on PT screen elements and functions.

Use the NT-series Support Tool for Windows (version 3.2 or higher) for operations such as creating screens displayed on the PT, registering screen elements, and allocating PT memory.

The procedures for creating screens are the same as they are when using the regular Memory Link method. Words and bits are allocated to PM0000 to PM9999 of PT memory based on the type of data being allocated. PT memory can be allocated as words and bits just like I/O area words and bits.

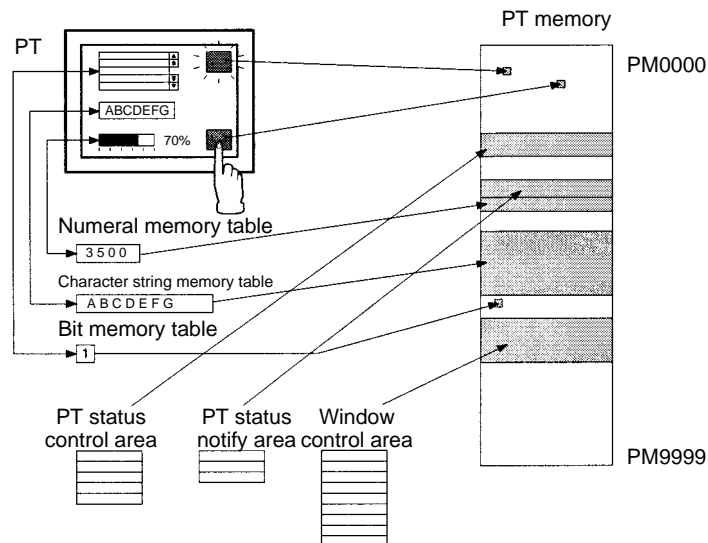

### 6-4-1 Precautions when Allocating Data to PT Memory

Observe the following precautions when allocating data in the PT memory of a PT with a DeviceNet Interface Unit installed.

- Allocate the PT status control area to the DeviceNet Interface Unit's output area if at all possible. It won't be possible to control the PT if the PT status control area is allocated to the Unit's input area. Also, exchanging data by message communications takes some time, so it may not be possible to control the PT as expected if message communications are used.



- Allocate the PT status notify area to the DeviceNet Interface Unit's input area if at all possible. It won't be possible to receive notifications from the PT if the PT status notify area is allocated to the Unit's output area. Also, exchanging data by message communications takes some time, so changes in PT status may not be recognized immediately if message communications are used.
- When the DeviceNet Interface Unit is being used, the PT status notify area requires one word more than it does with the regular Memory Link because the first word of the PT status notify area is used to indicate the screen number of the current PT screen. Refer to *1-5-2 Contrast with the Regular Memory Link Method* for more details.

PT Status Notify Area with the Regular Memory Link

Word	15	14	13	12	11	10	9	8	7	6	5	4	3	2	1	0	Bit
m	Numeral/character string memory table number (4-digit BCD or hexadecimal value)																
m + 1	PT status notify bits										0	0			0		

PT Status Notify Area with the DeviceNet Interface Unit

Word	15	14	13	12	11	10	9	8	7	6	5	4	3	2	1	0	Bit
m					Screen number (4-digit BCD)												
m + 1	Numeral/character string memory table number (4-digit BCD or hexadecimal value)																
m + 2	PT status notify bits										0	0			0		

- Some data is transmitted in both directions (PT ↔ Host) such as the window control area, numeral memory tables, and character string memory tables. When two-way data is allocated to the DeviceNet Interface Unit's output area or input area, only that one direction of data flow can be used. Only the control from the host can be used if the data is allocated to the output area and only the notification to the host can be used if the data is allocated to the input area. Message communications provide two-way data exchange, but responses may be delayed.
- Do not allocate the following elements to the DeviceNet Interface Unit's output area. Doing so will disable the element's functions.
  - Touch switch notification bits used for notification to the host
  - Numeral and character string memory tables used for numeral and character string inputs
- Do not allocate the following elements to the DeviceNet Interface Unit's input area. Doing so will disable the element's functions.
  - Lamp bits of lamps or touch switches
  - Numeral and character string memory tables written from the host
  - Bit memory tables

# SECTION 7

## Message Communications

This section explains how to use message communications with a DeviceNet Interface Unit and how to use the PT when message communications are being used.

7-1	Overview of Message Communications .....	84
7-1-1	Exchanging Data with the DeviceNet Interface Unit .....	84
7-1-2	Data Flow of Explicit Messages .....	84
7-2	Using Message Communications .....	85
7-2-1	EXPLICIT MESSAGE SEND (FINS Command 28 01) .....	85
7-2-2	Using the CMND Instruction in CVM1 and CV-series PCs .....	87
7-2-3	Using the IOWR Instruction in CS1-series and C200HX/HG/HE PCs .....	91
7-3	Explicit Messages .....	99
7-3-1	Supported Explicit Messages .....	99
7-3-2	PT Memory Read (H→L) .....	99
7-3-3	PT Memory Read (L→H) .....	100
7-3-4	PT Memory Write (H→L) .....	101
7-3-5	PT Memory Write (L→H) .....	102
7-4	Sample Program .....	103

## 7-1 Overview of Message Communications

Explicit messages can be sent between nodes in a DeviceNet network to transfer data and control other nodes.

The DeviceNet Interface Unit can freely write the contents of PT memory from the Master using DeviceNet explicit messages. This function allows PT memory outside of the allocated input and output areas to be accessed from the host to control the PT or read its status.

### 7-1-1 Exchanging Data with the DeviceNet Interface Unit

Data can be exchanged between the host (Master) and a DeviceNet Interface Unit using message communications to control the PT or read its status.

PT data (control/notify areas, elements, etc.) must be allocated to PT memory to enable explicit message communications from the Master (PC) to the PT via the DeviceNet Interface Unit. (The allocation method is the same as a regular link method.)

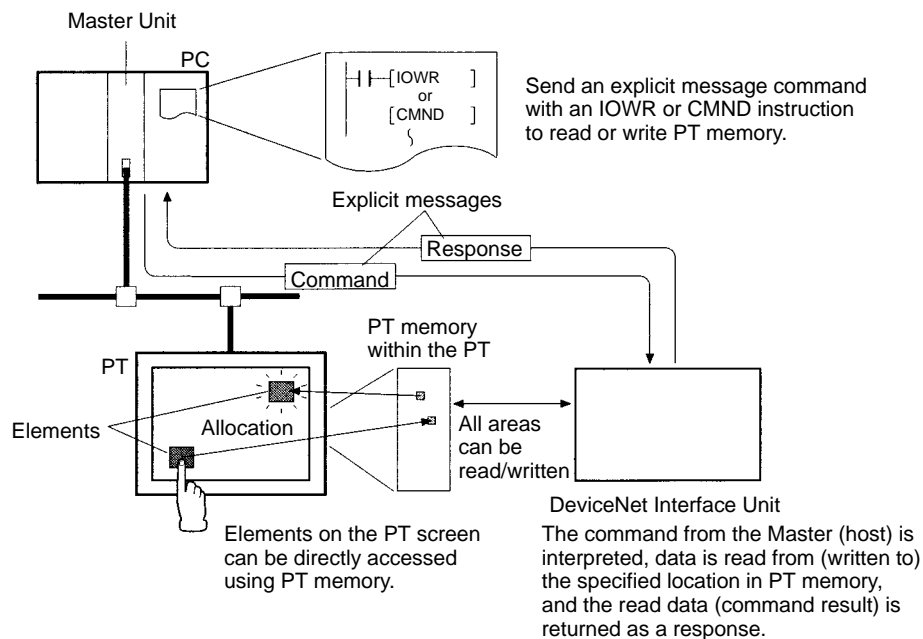

- Reference**
1. Use the EXPLICIT MESSAGE SEND (28 01) FINS command when sending an explicit message from an OMRON Master Unit.  
With CVM1/CV-series PCs, send FINS commands with the CMND instruction. With CS1-series or C200HX/HG/HE PCs, send FINS commands with the IOWR instruction.
  2. Explicit messages cannot be sent when a C200HS is used as the Master. (Data can only be read and written with remote I/O communications.)

### 7-1-2 Data Flow of Explicit Messages

When sending an explicit message, execute the CMND or IOWR instruction in the ladder program to send the EXPLICIT MESSAGE SEND (28 01) FINS command to the DeviceNet Master Unit in the local node.

The Master Unit removes the FINS header from the received FINS command, converts the command to an explicit message, and transmits it to the destination Slave (PT).

Similarly, the Master Unit attaches a FINS header to the response from the PT and returns it to the CPU Unit as a FINS response.

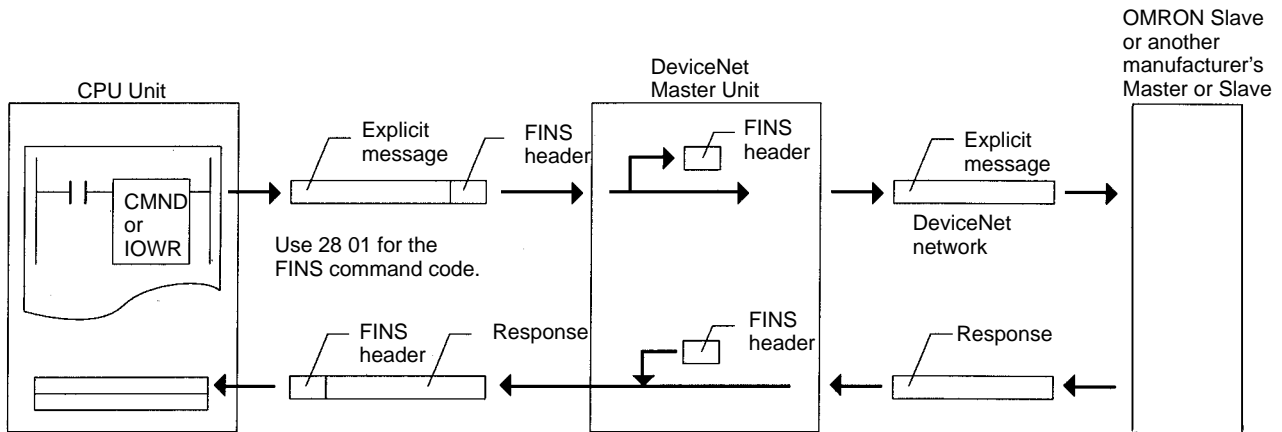

**Reference** When sending an explicit message, specify the DeviceNet Master Unit in the local node as the destination of the FINS command. The final destination Slave (PT) is specified in the command data of the FINS command.

## 7-2 Using Message Communications

This section explains how to use the FINS command (code 28 01) that sends explicit messages as well as the CMND and IOWR instructions. Refer to 7-3 *Explicit Messages* for details on the contents of explicit messages.

### 7-2-1 EXPLICIT MESSAGE SEND (FINS Command 28 01)

The EXPLICIT MESSAGE SEND command is used to send an explicit DeviceNet message to the DeviceNet Master Unit.

#### Command Block

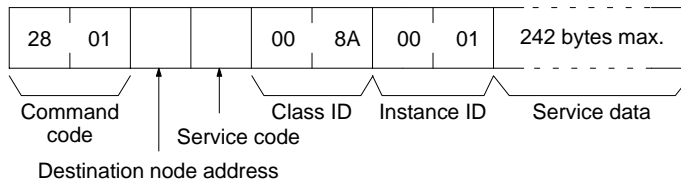

#### Response Block

##### Normal Response

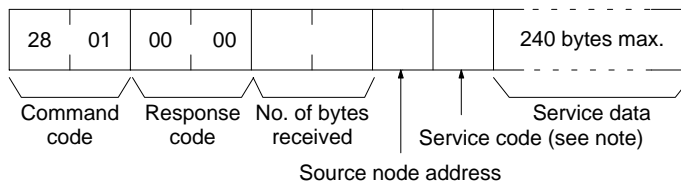

**Note** For a normal response, the leftmost bit of the service code specified in the command will be turned ON and then returned. For example, a command service code of 32 Hex is returned as B2 Hex in the response.

##### Error Responses

The following response is returned if an error occurs for the explicit message.

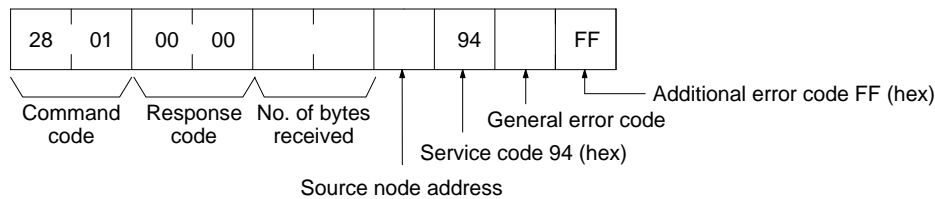

The following response is returned if the explicit message cannot be sent or times out.

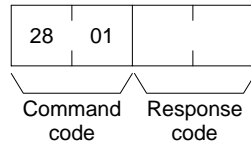

**Parameters**

**Destination node address (command):** The node address of the destination of the explicit message. (The node address of the local Master Unit is specified in the control data for the CMND(194) or IOWR instruction, but the node address of the actual destination is specified here in the FINS command.)

**Service code (command, response):** A service code defined for DeviceNet. In a normal response, bit 15 of the service code specified in the command will be turned ON and returned. In an error response, 94 hex will always be returned.

**Class ID (command):** The class ID of the destination of the explicit message. The class ID is always 008A Hex when reading or writing the DeviceNet Interface Unit's PT memory.

**Instance ID (command):** The instance ID of the destination of the explicit message. The instance ID is always 0001 Hex when reading or writing the DeviceNet Interface Unit's PT memory.

**Service data (command, response):** The data defined for the services codes.

**No. of bytes received (response):** The number of bytes received from the destination node address (local node).

**Destination node address (response):** The node address of the OMRON Special I/O Slave Unit or slave manufactured by another company to which the explicit message was sent is returned.

**General Error Code (response):** The following error codes may be returned.

General error code	Error name	Cause of error
0C Hex	Object state conflict	The PT is not able to process the message in its current status.
08 Hex	Service not supported	The Service Code is not supported.
02 Hex	Resource unavailable	The Instance ID is not supported.
09 Hex	Invalid attribute value	The Attribute Value is not supported.
15 Hex	Too much data	The data string is too long.
13 Hex	Not enough data	The data string is too short or there is an odd number of bytes.
14 Hex	Attribute not supported	The Attribute ID is not supported.
20 Hex	Invalid parameter	An incorrect PT memory address was specified.
11 Hex	Reply data too large	More than 250 bytes of read data was returned when reading PT memory.
16 Hex	Object does not exist	The Class ID is not supported.

**Note** 1. Unlike other FINS commands, this command is addressed to the local node's DeviceNet Master Unit. The actual destination of the explicit message is given in the command data, as described above.

Always specify the local node's DeviceNet Master Unit in the control code of the CMND or IOWR instruction. An error will occur if another node's Master Unit is specified.

2. If the DeviceNet Master Unit receives an explicit message, it will automatically return a response.

**Reference** Refer to 7-3 *Explicit Messages* for details on the service code, class ID, instance ID, and service data to use when sending an explicit message to the DeviceNet Master Unit.

### 7-2-2 Using the CMND Instruction in CVM1 and CV-series PCs

Use the CMND instruction when sending explicit messages from a CVM1/CV-series PC.

**Reference** The DeviceNet Master Unit must be registered in the routing table (local network table) of the CVM1 or CV-series PC to execute the CMND(194) instruction from the PC.

The local network table of the routing tables lists the unit numbers of the Communications Units mounted to the PC and the addresses of the Networks to which each Unit belongs. An example local network table is shown below.

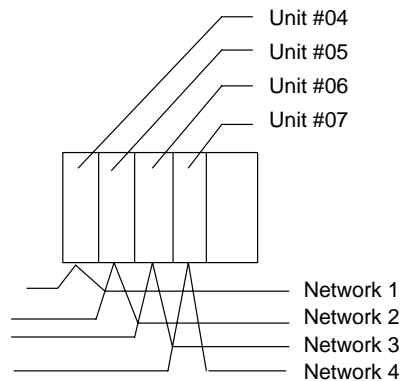

Address of local network	CPU Bus Unit's unit number
001	04
002	05
003	06
004	07

The unit number of the DeviceNet Master Unit as a CPU Bus Unit is the number set on the rotary switches on the front panel. The network address is the address of the Network to which the CPU Bus Unit is connected.

Routing tables are set from the Support Software using the following display to input the settings.

{ Local Network Table }

#	Loc Netuk	SIOU unit #	#	Loc Netuk	SIOU unit #
1	001	00	9		
2			10		
3			11		
4			12		
5			13		
6			14		
7			15		
8			16		

Item	Setting method
Loc Netwk	The network address of each CPU Bus Unit mounted to the PC (1 to 127)
SIOU unit #	The unit number of each CPU Bus Unit mounted to the PC and connecting it to a network (0 to 15)

**DELIVER COMMAND:  
CMND(194)**

Specify CMND(194) in the ladder program as shown below.

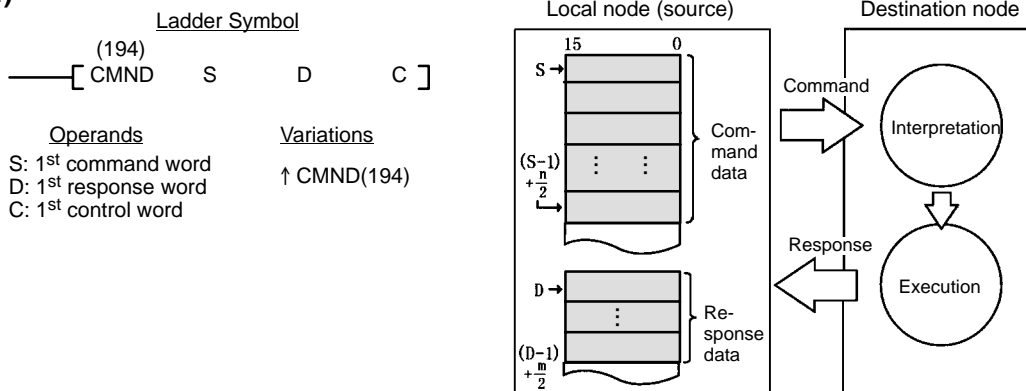

**Description**

CMND(194) transmits n bytes of command data (the data after command code 28 01) beginning at word S to the destination node. The m bytes of response data (the data after command code 28 01) are stored in the local node beginning at word D.

**Control Data**

The control words, beginning with C, specify the number of bytes of control data to be sent, the number of bytes of response data to be received, the destination node, and other parameters. Some control data parameters depend on the destination.

Word	Bits 00 to 07	Bits 08 to 15
C	Number of command bytes to send: 0 to 1990 (i.e., 0000 to 07C6 Hex)	
C+1	Number of response bytes to receive: 0 to 1990 (i.e., 0000 to 07C6 Hex)	
C+2	Destination network address (0 to 127, i.e., 00 to 7F Hex) <sup>1</sup>	Set to 0.
C+3	Destination unit FINS address <sup>2</sup>	Destination node address <sup>3</sup>
C+4	Bits 00 to 03: No. of retries (0 to 15, i.e., 0 to F Hex) Bits 04 to 07: Set to 0.	Bits 08 to 11: Transmission port number (0 to 7 Hex) Bit 12 to 14: Set to 0. Bit 15: ON: No response. OFF: Response returned.
C+5	Response monitoring time (0001 to FFFF Hex = 0.1 to 6553.5 seconds) <sup>4</sup>	

- Note**
1. Set the destination network address to 00 when transmitting within the same network.
  2. Indicates a Unit as shown in the following table.

Unit	Setting
CPU Unit	00
User program in FA computer	01
CPU Bus Unit	10 to 1F Hex: Unit numbers 0 to 15 FE Hex: The local Unit

3. Values of 01 to 3F Hex indicate nodes 1 to 63.
4. Designates the length of time that the PC retries transmission when bit 15 of C+3 is OFF and no response is received. The default value is 0000, which indicates 2 seconds.

**Reference** When sending explicit messages, set the response monitoring time in C+5 to 0014 Hex (2 seconds) or higher. If a shorter time is set, communications may still be busy when the next command is sent after a timeout occurs.

The maximum number of bytes that can be transferred (shown above) is the maximum number of bytes allowed with CMND(194). The actual number of bytes that can be sent or received depends upon the explicit message.

**Using CMND(194)**

Normally, CMND(194) is used with the following flags ANDed as executions conditions to ensure that any previous network communications operation has completed before CMND(194) is executed. The Port Enabled Flag for the communications port and the Message Enabled Flag for the Master Unit are generally programmed as follows:

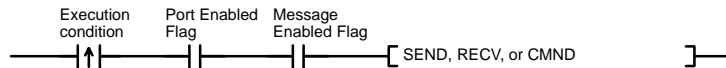

**Communications Flags**

The following table shows the flags that are normally used when executing CMND(194).

Flag	Functions
Port #0 to #7 Enabled Flags (A50200 to A50207)	Enabled Flags A50200 to A50207 are OFF during communications instruction execution for ports #0 to #7, respectively, and turn ON when execution has completed (regardless of whether or not an error has occurred).  Do not start a communications instruction for a port unless the corresponding Enabled Flag is ON.
Port #0 to #7 Execution Error Flags (A50208 to A50215)	Execution Error Flags A50208 to A50215 turn OFF following normal completion of a communications instruction (i.e., after reception of response signal) for ports #0 to #7, respectively. These flags turn ON after an unsuccessful communications instruction attempt.  Execution Error Flags will maintain status until the next communications instruction. They will turn ON when the next communications instruction is executed even if an error occurred for the last instruction.  Error types: Time-out error (command/response time greater than the response monitoring time set in the control words) Transmission data errors
Message Communications Enabled Flag in the Master Unit status area (bit 12 in CIO 1500 + (25 x unit No.))	The Communications Enabled Flag turns OFF when message communications are not possible for the Master Unit due to detection of Bus Off or other errors. This flag is ON when message communications are possible.

**Note** The behavior of the Message Communications Enabled Flag in the CVM1/CV-series PCs is different from the behavior in the C200HX/HG/HE PCs.

**Reference** In the CVM1/CV-series PCs, the 8 ports can be used independently to execute network instructions SEND(192), RECV(193), and CMND(194).

**Communications Flag Operation**

The relationship between the the Message Communications Enabled Flag and the NS indicator is shown in the following table.



Message Communications Enabled Flag	Network status	NS indicator
ON (1)	Communications connection made (network normal)	Lit green
	Communications connection not made (network normal, but communications not established)	Flashing green
	Non-fatal communications error (error in one or more Slaves)	Flashing red
OFF (0)	Offline or power supply is off (no power supply, resetting, minor failure, or send error)	Not lit
	Fatal communications error	Lit red

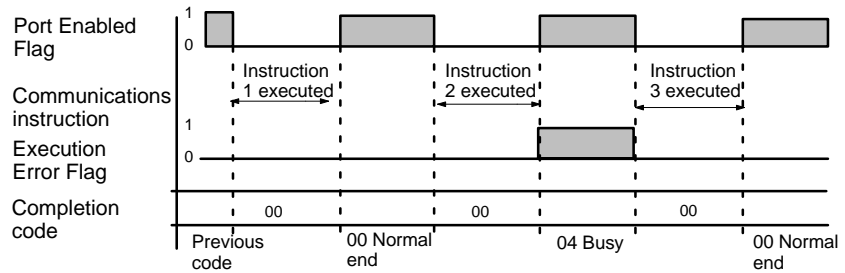

**Completion Codes**

Completion codes are stored in memory as shown in the following table at the completion of execution of CMND(194). The completion code will be 00 or 0000 during execution of the instruction.

Words	Functions
Port #0 to #7 Completion Codes (A503 to A510)	A503 to A510 contain the completion codes for the results of communications instruction execution for ports #0 to #7, respectively.

The completion codes are stored as 2 bytes of data (1 word) upon completion of the execution of CMND(194). These codes are the same as the response codes for FINS commands. The first byte of the completion code is placed in bits 08 to 15 and the second byte is placed in bits 00 to 07. Refer to the *DeviceNet (CompoBus/D) Operation Manual (W267)* for more details.

**Timing the Reading of Responses**

When reading the response from the DeviceNet Interface Unit after execution of CMND(194), read the response on the rising edge (upward differentiation) of the Port Enabled Flag, as shown in the following diagram.

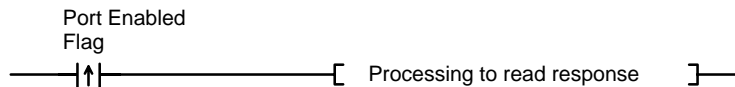

### 7-2-3 Using the IOWR Instruction in CS1-series and C200HX/HG/HE PCs

Use the IOWR instruction when sending explicit messages from a CS1-series or C200HX/HG/HE PC.

#### CS1-series PCs

Specify IOWR in the CS1-series PC's ladder program as shown below.

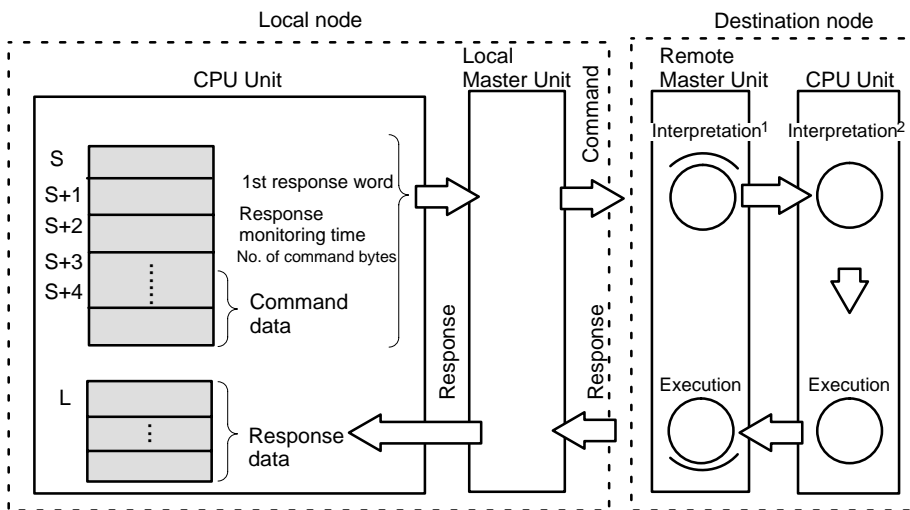
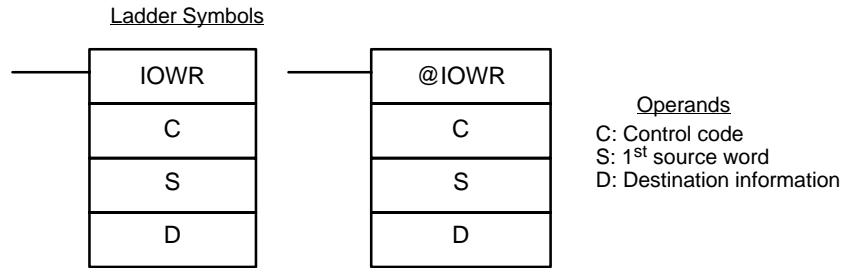

1: For commands addressed to Master Unit  
 2: For commands addressed to CPU Unit

#### Description

IOWR transfers n words of data beginning at S (beginning with command code 28 01 Hex) through the local node's Master Unit to the Master Unit or CPU Unit at the specified destination node. The control code (C) specified parameters for the instruction as shown in the following illustration.

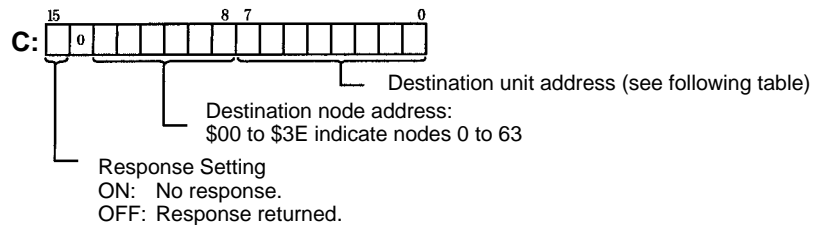

#### Destination Unit Address

Unit	Setting
CPU Unit	00
Communications Unit	FE
Special I/O Unit	\$10 to \$1F: Unit No. + 10

The source words (starting with S) provide execution parameter and the command data as shown in the following table.

Word	Contents
S	Address of first word containing response (See <i>Specifying the Leading Address of the Response Words</i> on page 93.)
S+1	
S+2	Response monitoring time (hex) 0000: 2 s 1000 to 028F: 0.1 to 65.5 s (units of 0.1 s) Above 028F: 65.5 s
S+3	Number of command bytes (hex) 0000 to 00F8: 0 to 248 bytes
S+4	Command data beginning with command code
.	
.	
.	

The destination information provides the unit number of the destination Unit and the number of words to be written, as shown in the following diagram.

Word	Contents
D	Unit number of the destination Unit (0000 to 000F hex = 0 to 15)
D+1	Number of words to write (0001 to 0080 hex = 1 to 128)

- Reference**
1. When sending explicit messages, set the response monitoring time in S+2 to 0014 Hex (2 seconds) or higher. If a shorter time is set, communications may still be busy when the next command is sent after a timeout occurs.
  2. The maximum number of bytes that can be transferred (shown above) is the maximum number of bytes allowed with IOWR in CS1-series PCs. The actual number of bytes that can be sent or received depends upon the explicit message.

#### **IOWR Data Area Ranges for CS1-series PCs**

The following tables shows the data areas that can be used for each parameter of IOWR.

Area	C	S	D
CIO Area	CIO 0000 to CIO 6143		CIO 0000 to CIO 6142
Work Area	W000 to W511		W000 to W510
Holding Bit Area	H000 to H511		H000 to H510
Auxiliary Bit Area	A000 to A959		A000 to A958
Timer Area	T0000 to T4095		T0000 to T4094
Counter Area	C0000 to C4095		C0000 to C4094
DM Area	D00000 to D32767		D00000 to D32766
EM Area without bank	E00000 to E32767		E00000 to E32766
EM Area with bank	En_00000 to En_32767 (n = 0 to C)		En_00000 to En_32766 (n = 0 to C)
Indirect DM/EM addresses in binary	@ D00000 to @ D32767 @ E00000 to @ E32767 @ En_00000 to @ En_32767 (n = 0 to C)		

Area	C	S	D
Indirect DM/EM addresses in BCD	*D00000 to *D32767 *E00000 to *E32767 *En_00000 to *En_32767 (n = 0 to C)		
Constants	#0000 to #FFFF (binary)	---	D: #0000 to #000F D+1: #0001 to #0080
Data Registers	DR0 to DR15	---	---
Index Registers	---		
Indirect addressing using Index Registers	,IR0 to ,IR15 -2048 to +2047 ,IR0 to -2048 to +2047 ,IR15 DR0 to DR15, IR0 to IR15 ,IR0(++) to ,IR15(++) ,-(-- )IR0 to ,-(-- )IR15		

### Specifying the Leading Address of the Response Words

Specify the leading address as shown in the following table. These tables show only the ranges that can be used with message communications (limited to accessing word units). Refer to the PC's manuals for more details.

Word	Bits 00 to 07	Bits 08 to 15
S	Data area specifier	Leftmost 2 digits of address
S+1	Rightmost 2 digits of address	Bit (always 00)

Area	Allowed range	Data area specifier (Hex)	Address (Hex)
CIO Area	CIO 0000 to CIO 6143	B0	0000 to 17FF
Work Area	W000 to W511	B1	0000 to 01FF
Holding Bit Area	H000 to H511	B2	0000 to 01FF
Auxiliary Bit Area	A000 to A959	B3	0000 to 03BF
Timer Area (PVs)	T0000 to T4095	89	0000 to 0FFF
Counter Area (PVs)	C0000 to C4095	89	8000 to 8FFF
DM Area	D00000 to D32767	82	0000 to 7FFF
EM Area (Current bank)	E00000 to E32767	98	0000 to 7FFF
EM Area (EM banks 0 to 12)	E0_00000 to E0_32767 : : : : EC_00000 to EC_32767	A0 (bank 0) : : : : AC (bank 12)	0000 to 7FFF : : : : 0000 to 7FFF

C200HX/HG/HE PCs

Specify IOWR in the C200HX/HG/HE PC's ladder program as shown below.

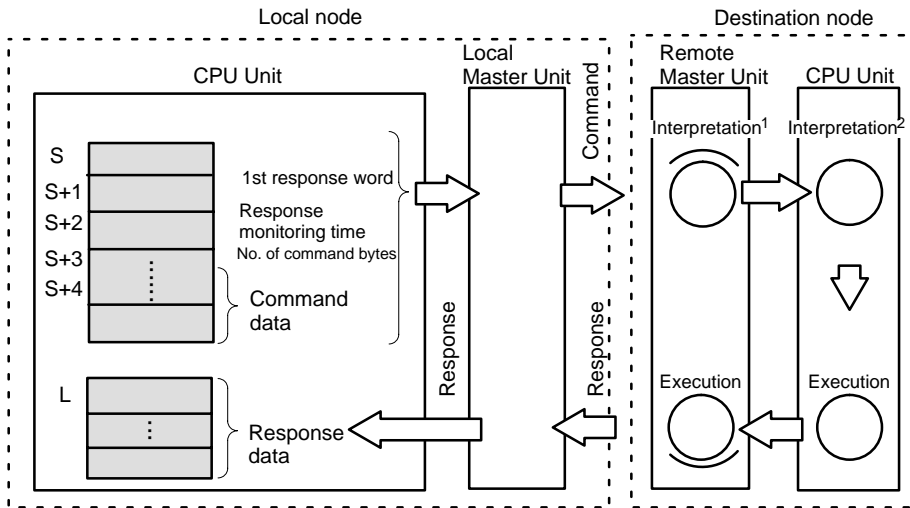
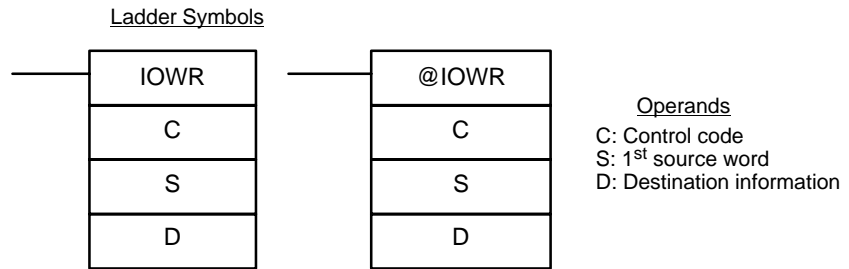

1: For commands addressed to Master Unit  
 2: For commands addressed to CPU Unit

**Description**

IOWR transfers n words of data beginning at S (beginning with command code 28 01 Hex) through the local node's Master Unit to the Master Unit or CPU Unit at the specified destination node. The control code (C) specified parameters for the instruction as shown in the following illustration.

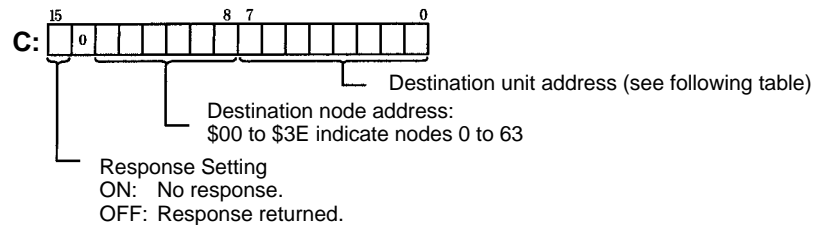

**Destination Unit Address**

Unit	Setting
CPU Unit	00
Communications Unit	FE
Special I/O Unit	\$10 to \$1F: Unit No. + 10

The source words (starting with S) provide execution parameter and the command data as shown in the following table.

Word	Contents
S	Address of first word containing response (See <i>Specifying the Leading Address of the Response Words</i> on page 95.)
S+1	
S+2	Response monitoring time (hex) 0000: 2 s 1000 to 028F: 0.1 to 65.5 s (units of 0.1 s) Above 028F: 65.5 s
S+3	Number of command bytes (hex) 0000 to 00F8: 0 to 248 bytes
S+4	Command data beginning with command code
.	
.	
.	

The destination information provides the unit number of the destination Unit and the number of words to be written, as shown in the following diagram.

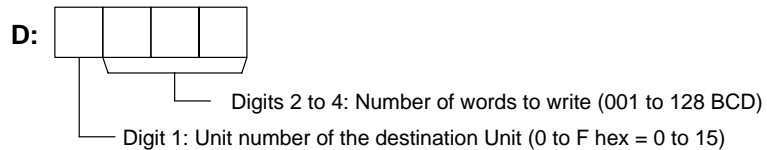

- Note**
1. When sending explicit messages, set the response monitoring time in S+2 to 0014 Hex (2 seconds) or higher. If a shorter time is set, communications may still be busy when the next command is sent after a timeout occurs.
  2. The maximum number of bytes that can be transferred (shown above) is the maximum number of bytes allowed with IOWR in C200HX/HG/HE PCs. The actual number of bytes that can be sent or received depends upon the explicit message.

### **IOWR Data Area Ranges for C200HX/HG/HE PCs**

The following tables shows the data areas that can be used for each parameter of IOWR.

Area	C	S	D
Internal Relay Area 1	IR 000 to IR 235		
Special Relay Area 1	SR 236 to SR 255		
Special Relay Area 2	SR 256 to SR 299		
Internal Relay Area 2	IR 300 to IR 511		
Holding Relay Area	HR 00 to HR 99		
Auxiliary Relay Area	AR 00 to AR 27		
Link Relay Area	LR 00 to LR 63		
Timer/Counter Area	TC 000 to TC 511		
Data Memory Area	DM 0000 to DM 6599		
Fixed DM Area	DM 6600 to DM 6655		
Extended DM Area	EM 0000 to EM 6143		
Constants	0000 to FFFF	Not usable	0001 to F128

### **Specifying the Leading Address of the Response Words**

Specify the leading address as shown in the following table. These tables show only the ranges that can be used with message communications (limited to accessing word units). Refer to the PC's manuals for more details.

Word	Bits 00 to 07	Bits 08 to 15
S	Data area specifier	Leftmost 2 digits of address
S+1	Rightmost 2 digits of address	Bit (always 00)

Area	Allowed range	Data area specifier (Hex)	Address (Hex)
IR Area	IR 000 to IR 511	80	0000 to 01FF
Link Area	LR 00 to LR 63	80	03E8 to 0427
Holding Area	HR 00 to HR 99	80	0428 to 048B
Auxiliary Area	AR 00 to AR 27	80	048C to 04A7
Timer/counter PVs	TIM/CNT 000 to TIM/CNT 511	81	0000 to 01FF
DM Area	DM 0000 to DM 6655	82	0000 to 19FF
EM Area	EM 0000 to EM 6143	98 (Current bank), 90 to 97 (banks 0 to 7), A8 to AF (banks 8 to 15)	0000 to 17FF

**Using IOWR**

Use the Master Unit's Message Communications Enabled Flag as an execution condition for IOWR. Be sure this Flag is ON before executing IOWR. If this Flag is OFF, a Special I/O Unit error may occur.

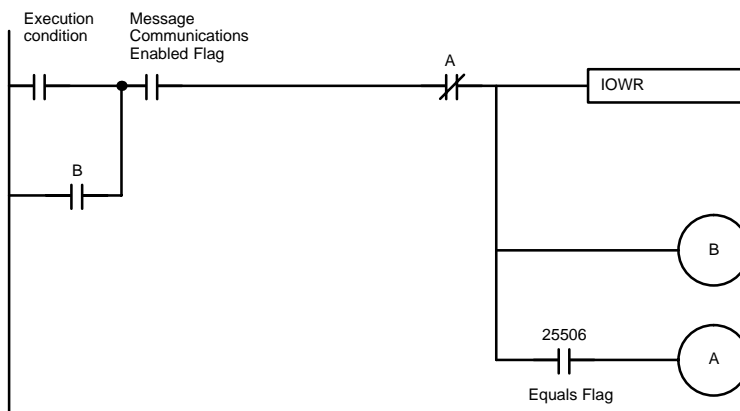

**Note** Use the Equals Flag (SR 25506) to execute the instruction again when IOWR execution ends in an error. The status of the Equals Flag can be changed by other instructions; be careful of its location in the program.

**Communications Flags**

The following table shows the flags that are normally used when executing IOWR.

Flag	Address	Functions
Equals Flag	C200HX/HG/HE: SR 25506	The Equals Flag turns OFF when an error occurs in writing a command from the CPU Unit to the Master Unit.  This Flag turns ON after a command has been written normally from the CPU Unit to the Master Unit.
Error Flag	C200HX/HG/HE: SR25503	The Error Flag is OFF when all operands and the control code are legal.  This Flag turns ON when an illegal operand or control code is set (see note 1) or when there is an error in instruction execution.
Message Communications Enabled Flag in the Master Unit status area	CS1-series: Bit 12 in CIO 2001 + (10 x unit No.)  C200HX/HG/HE: Bit 12 in IR 101 + (10 x unit No.)	The Communications Enabled Flag turns OFF during message communications or when message communications are not possible.  This Flag is ON when message communications are possible.

**Note** 1. The number of words to write in D is not BCD or is not between 1 and 127. With indirect DM addressing, the DM contents are not BCD or exceed 6556.

The unit address of the local Master Unit is not between 0 and F, the Master Unit is mounted on a Slave Rack, etc.

2. The behavior of the Message Communications Enabled Flag in CVM1 and CV-series PCs is different from the behavior in CS1-series and C200HX/HG/HE PCs.
3. With CS1-series PCs, there are no memory addresses for the Equals Flag and the Error Flag.

**Timing the Reading of Responses**

When reading the response from the DeviceNet Interface Unit after execution of IOWR, read the response in the cycle after the one in which IOWR is executed and when the Message Communications Enabled Flag is ON.

Even if IOWR execution is finished, the status of the Message Communications Enabled Flag will not change until the next peripheral servicing in the CPU Unit. If the response is returned in the same cycle as IOWR execution, the Message Communications Enabled Flag will remain ON. If the response is not received until the next cycle, the Flag will turn OFF during peripheral servicing and then turn ON at the next peripheral servicing after the response is received.

If the Message Communications Enabled Flag is used in the same cycle as the execution condition for reading the response after execution of IOWR, an attempt could be made to read the response even though it has not yet been returned.

**Response Received in the Same Cycle**

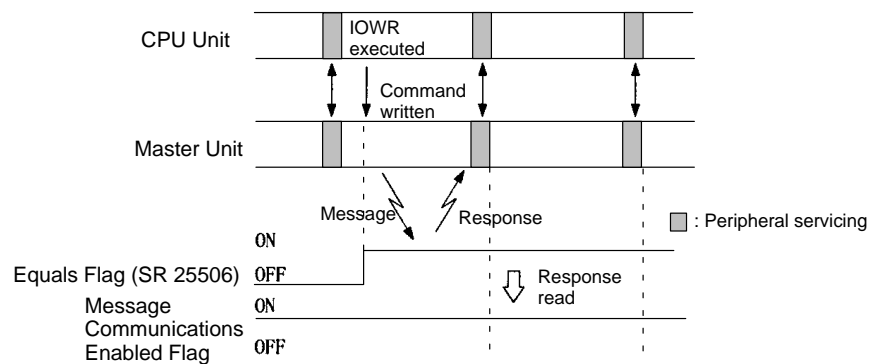

**Response Received in the Next Cycle**

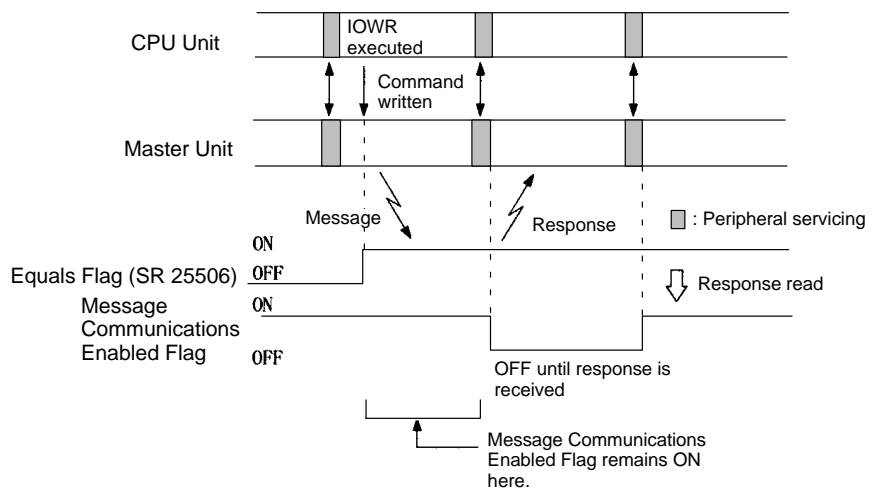



Use the type of programming shown below. The programming shown at the top will not always read the response properly.

**WRONG: Can Improperly Read Response**

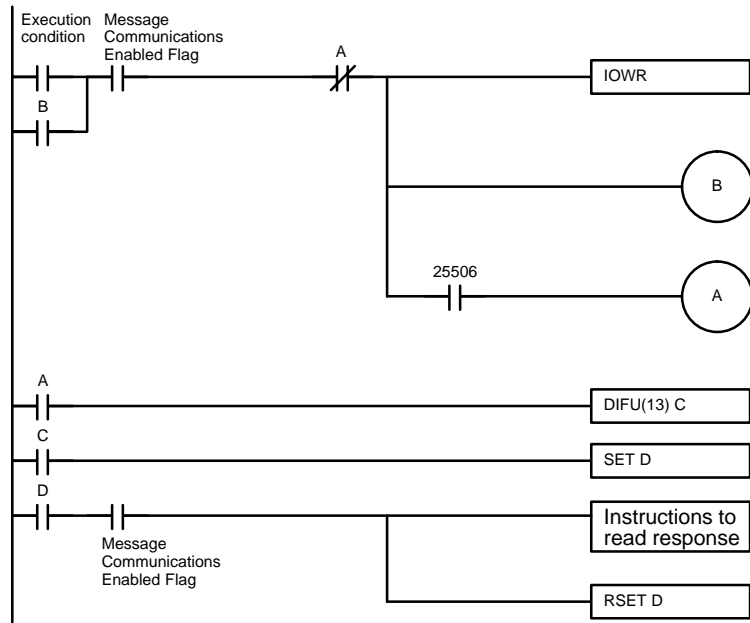

**CORRECT: Properly Reads Response**

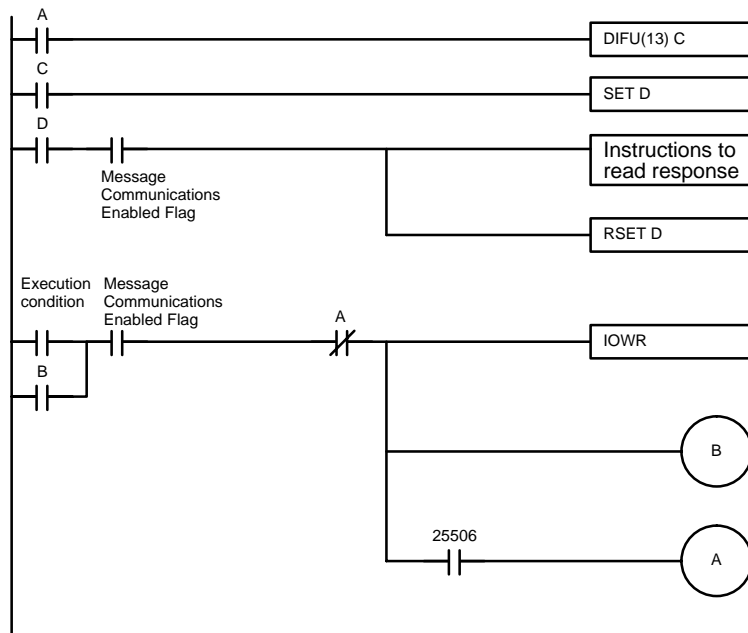

## 7-3 Explicit Messages

This section describes the explicit messages supported by the DeviceNet Interface Unit.

When sending explicit messages from an OMRON Master Unit, use the CMND or IOWR instruction to send the message data as an EXPLICIT MESSAGE SEND (28 01) FINS command. Only the normal response is shown here; refer to 7-2-1 EXPLICIT MESSAGE SEND (FINS Command 28 01) for details on responses returned when errors occur.

When sending explicit messages from another company's Master Unit, refer to that Master Unit's manuals for details on sending the message data shown here.

### 7-3-1 Supported Explicit Messages

The following table lists the explicit messages supported by the DeviceNet Interface Unit.

Explicit Message	Function	Class ID	Service code (see note)	Instance ID	Page
PT Memory Read (H→L)	Reads data from PT memory. The read data is returned with the high byte first and the low byte second in the words.	008A Hex	32 Hex (B2 Hex)	0001 Hex	99
PT Memory Read (L→H)	Reads data from PT memory. The read data is returned with the low byte first and the high byte second in the words.		33 Hex (B3 Hex)		100
PT Memory Write (H→L)	Writes data to PT memory. Specify the write data with the high byte first and the low byte second in the words.		34 Hex (B4 Hex)		101
PT Memory Write (L→H)	Writes data to PT memory. Specify the write data with the low byte first and the high byte second in the words.		35 Hex (B5 Hex)		102

**Note** The response service code is shown in parentheses.

### 7-3-2 PT Memory Read (H→L)

Reads the specified number of bytes of PT memory data beginning at the specified word address. The read data is returned with the high byte first and the low byte second in the words.

#### Command Block

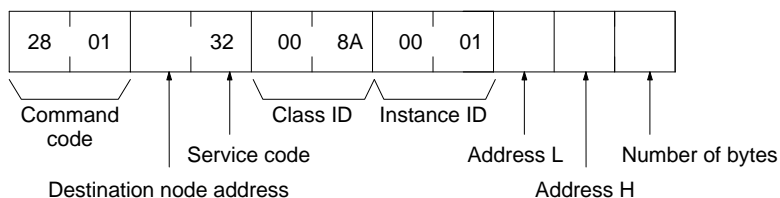

#### Response Block

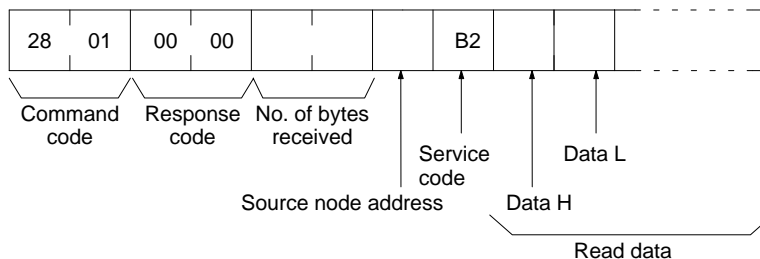

**Parameters**

**Address L, Address H, Number of bytes (command):**

Specify the leading PT memory address of the data and the number of bytes to be read. Specify these parameters in 2-digit hexadecimal. Always specify and even number of bytes to be read because an error will occur if an odd number is specified.

Address L: The rightmost 2 digits of the leading PT memory address

Address H: The leftmost 2 digits of the leading PT memory address

The max. number of bytes that can be read at one time is 250 bytes (FA Hex). When an OMRON Master is being used, the maximum is 240 bytes (F0 Hex).

**Read data (response):** The specified contents of PT memory are returned in 4-digit hexadecimal. The leftmost 2 digits (Data H) are first and the rightmost 2 digits (Data L) are second, as shown in the following diagram.

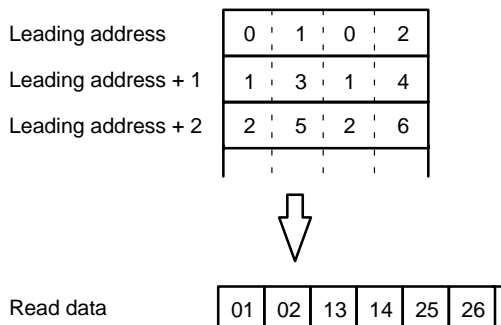

**7-3-3 PT Memory Read (L → H)**

Reads the specified number of bytes of PT memory data beginning at the specified word address. The read data is returned with the low byte first and the high byte second in the words.

**Command Block**

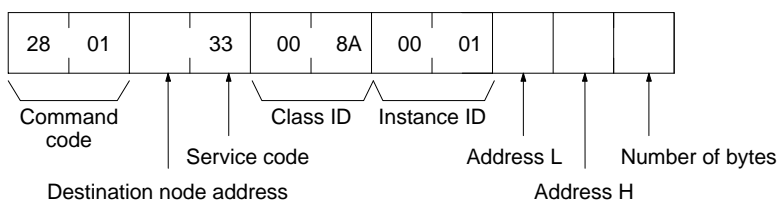

**Response Block**

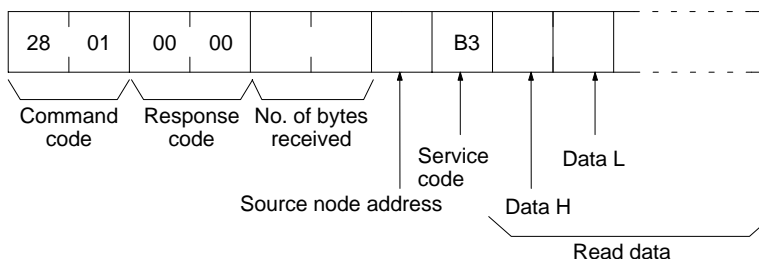

**Parameters**

**Address L, Address H, Number of bytes (command):**

Specify the leading PT memory address of the data and the number of bytes to be read. Specify these parameters in 2-digit hexadecimal. Always specify and even number of bytes to be read because an error will occur if an odd number is specified.

Address L: The rightmost 2 digits of the leading PT memory address

Address H: The leftmost 2 digits of the leading PT memory address

The max. number of bytes that can be read at one time is 250 bytes (FA Hex). When an OMRON Master is being used, the maximum is 240 bytes (F0 Hex).

**Read data (response):** The specified contents of PT memory are returned in 4-digit hexadecimal. The rightmost 2 digits (Data L) are first and the leftmost 2 digits (Data H) are second, as shown in the following diagram.

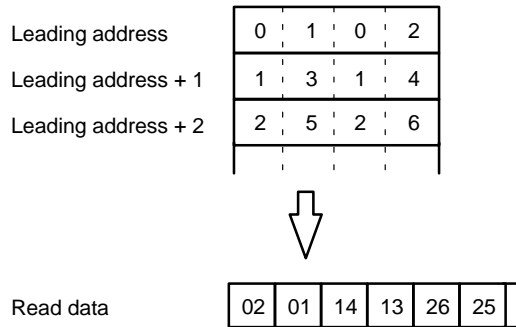

### 7-3-4 PT Memory Write (H→L)

Writes the specified data to PT memory beginning at the specified word address. The data is written to PT memory words with the leftmost byte (Data H) first and rightmost byte (Data L) second.

#### Command Block

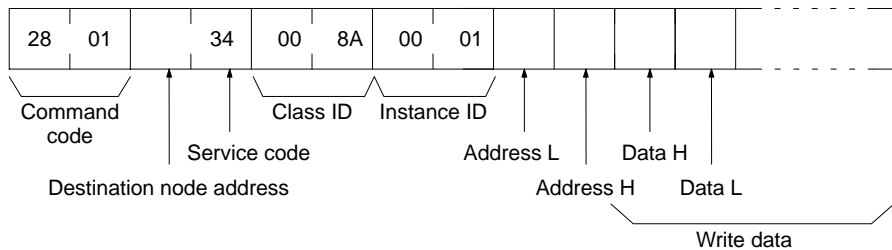

#### Response Block

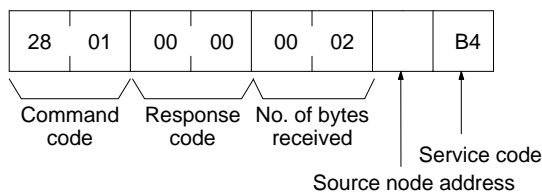

#### Parameters

##### Address L and Address H (command):

Specify the leading PT memory address where the data will be written. Specify both of these parameters in 2-digit hexadecimal.

Address L: The rightmost 2 digits of the leading PT memory address

Address H: The leftmost 2 digits of the leading PT memory address

The max. number of bytes that can be written at one time is 248 bytes (F8 Hex). When an OMRON Master is being used, the maximum is 240 bytes (F0 Hex).

**Write data (command):** The write data is the 4-digit hexadecimal data that is written to PT memory. Data is written to PT memory beginning at the specified

leading address with the leftmost 2 digits (Data H) first and the rightmost 2 digits (Data L) second, as shown in the following diagram.

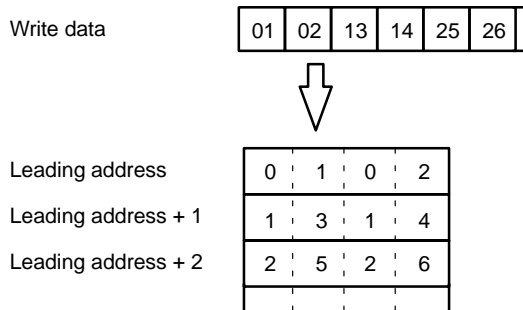

### 7-3-5 PT Memory Write (L→H)

Writes the specified data to PT memory beginning at the specified word address. The data is written to PT memory words with the rightmost byte (Data L) first and leftmost byte (Data H) second.

#### Command Block

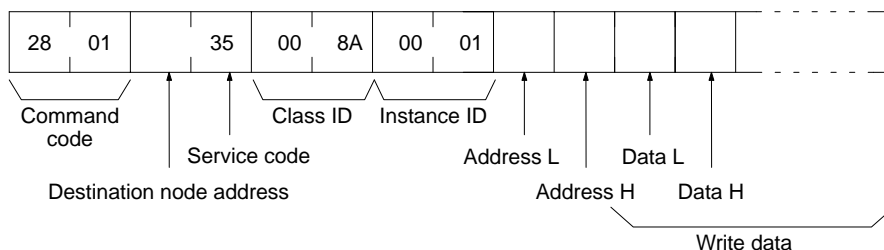

#### Response Block

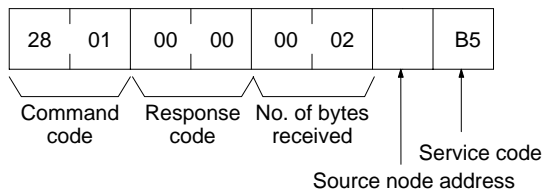

#### Parameters

##### Address L and Address H (command):

Specify the leading PT memory address where the data will be written. Specify both of these parameters in 2-digit hexadecimal.

Address L: The rightmost 2 digits of the leading PT memory address

Address H: The leftmost 2 digits of the leading PT memory address

The max. number of bytes that can be written at one time is 248 bytes (F8 Hex). When an OMRON Master is being used, the maximum is 240 bytes (F0 Hex).

**Write data (command):** The write data is the 4-digit hexadecimal data that is written to PT memory. Data is written to PT memory beginning at the specified

leading address with the rightmost 2 digits (Data L) first and the leftmost 2 digits (Data H) second, as shown in the following diagram.

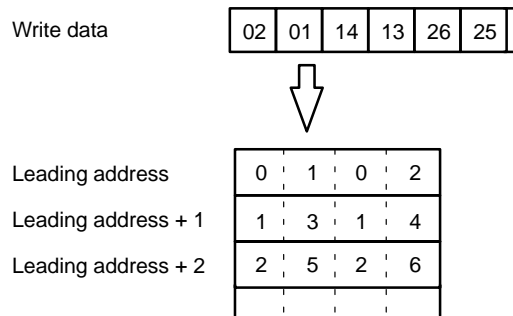

## 7-4 Sample Program

### Operation

This operation reads 10 bytes (5 words) of data beginning at PT memory address PM0100 in the Slave PT (DeviceNet Interface Unit's node number: 01) from the PC's Master (DeviceNet Unit with node number 63).

The command used to read the data is the EXPLICIT MESSAGE SEND command (command code 2801 Hex).

The explicit message used is PT Memory Read (L→H). This explicit message has the Service Code 33 Hex, Class ID 008A Hex, and Instance ID 0001 Hex.

The command and response data are stored in the PC's DM Area with the command data beginning at DM 1000 and the response data beginning at DM 2000 (07D0 Hex).

### IOWR Parameters

[IOWR C S D]

C: DM0000	3FFE Hex	Response required, destination node number 3F Hex (DeviceNet unit with node number 63), destination unit address FE Hex (Communications Unit)
S: DM1000	+0: 8207 Hex	Leading address for response: DM 2000
	+1: D000 Hex	(The contents of +0 and +1: 82 Hex: DM (Area type), 07D0 Hex: 2000 (address))
	+2: 0064 Hex	Response monitoring time: 10 seconds
	+3: 000B Hex	Number of command data bytes: 11 bytes
	+4: 2801 Hex	Command code: 2801 Hex (EXPLICIT MESSAGE SEND command)
	+5: 0133 Hex	Command parameters Destination node number 01, service code 33 Hex (PT Memory Read (L→H))
	+6: 008A Hex	Command parameters Destination Class ID: 008A Hex
	+7: 0001 Hex	Command parameters Destination Instance ID: 0001 Hex
	+8: 6400 Hex	Command parameters Leading PT memory address to read: 0100
	+9: 0A00 Hex	Command parameters Number of bytes to read: 10 bytes
D: #0010		Destination unit number: 0 Hex, Number of transfer words: 10 words (010 BCD)

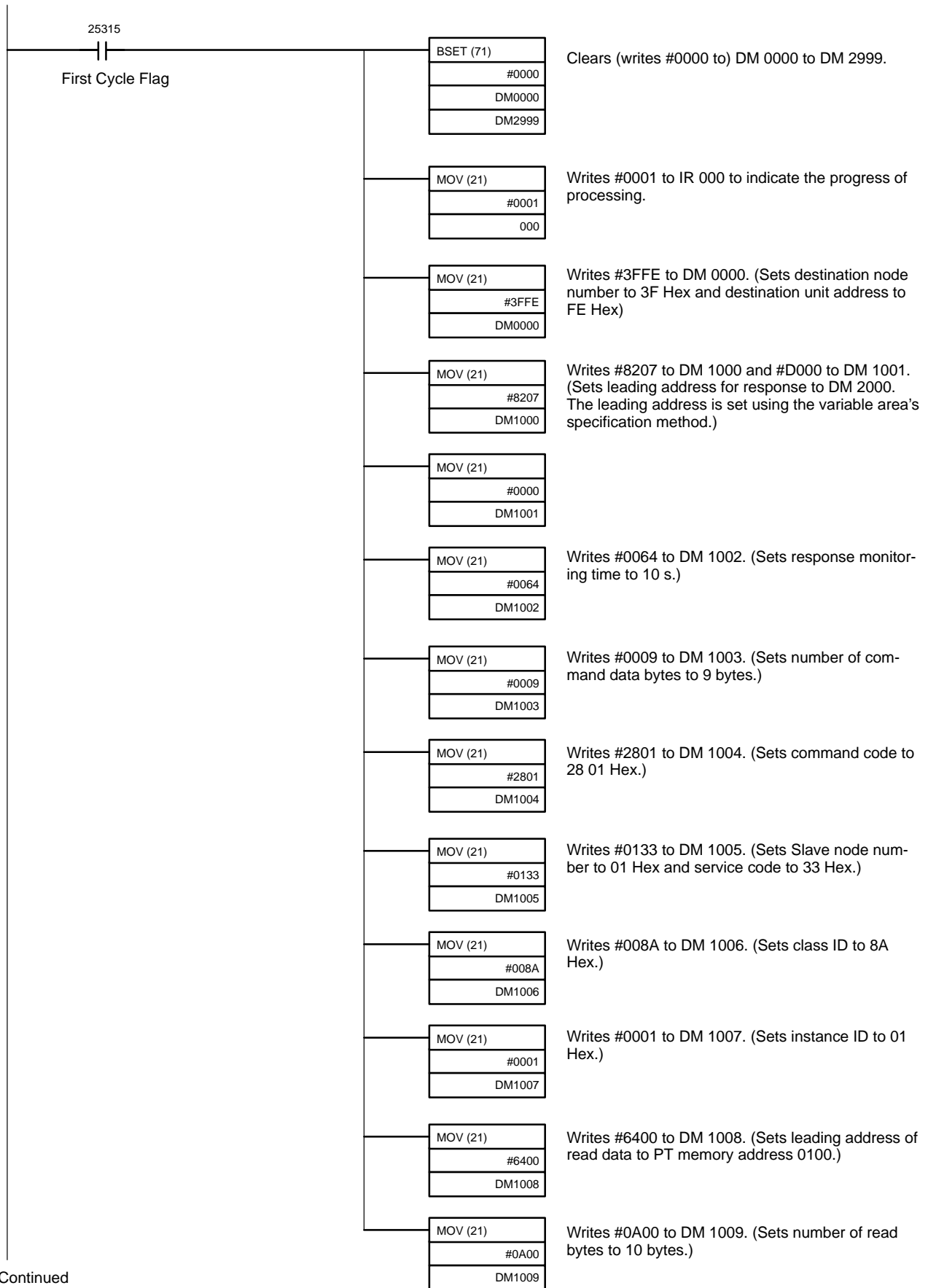

Continued on next page

Continued from previous page

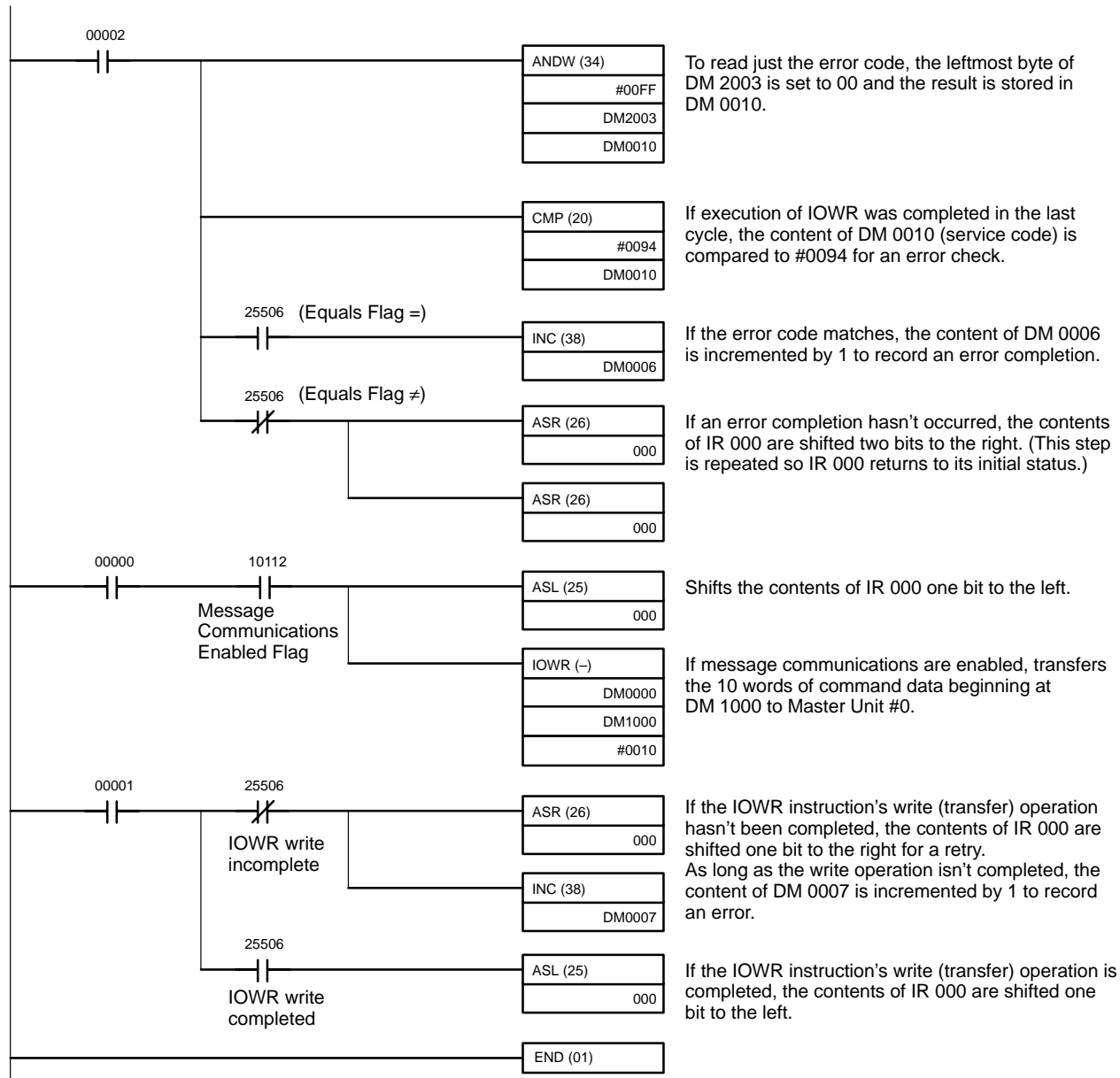



# SECTION 8

## Error Processing

This section explains how to troubleshoot errors that may occur when using the DeviceNet Interface Unit. Refer to the *DeviceNet (CompoBus/D) Operation Manual (W267)* and the PT's User's Manual for more details.

8-1	Error Screens Specific to the DeviceNet Interface Unit .....	108
8-2	Troubleshooting with the LED Indicators .....	109
8-2-1	Meaning of the LED Indicators .....	109
8-2-2	Identifying and Correcting Errors in Slaves .....	110

## 8-1 Error Screens Specific to the DeviceNet Interface Unit

The following error messages may be displayed when using a DeviceNet Interface Unit in addition to the regular error screens (error messages) displayed at the PT.

Message	Likely cause	Remedy
CompoBus/D I/F Unit Communications Error Connection can't be established with the DeviceNet Master.	Faulty communications cable connection	Check the network cable wiring.
	The Master's power supply is not ON.	Check the Master's power supply.
	The network power supply is not ON.	Check the network power supply.
CompoBus/D I/F Unit Communications Error Connection timeout error occurs.	Faulty communications cable connection	Check the network cable wiring.
	There is a problem with the Master's power supply.	Check the Master's power supply.
CompoBus/D I/F Unit Communications Error Network power supply error occurs.	The network power supply is not ON.	Check the network power supply.
	The communications cable is disconnected or broken.	Check the network cable.
CompoBus/D I/F Unit Communications Error Bus Off error occurs.	Noise	Check the following points and restart the PT. <ul style="list-style-type: none"> <li>• Are the Master/Slave communications speeds the same?</li> <li>• Are the cable lengths (trunk and branches) within specifications?</li> <li>• Are any cables disconnected, damaged, or loose?</li> <li>• Are termination resistors connected only at each end of the trunk line?</li> <li>• Is noise excessive?</li> </ul>
CompoBus/D I/F Unit Communications Error Duplicate MAC ID error occurs.	There is another device with the same MAC ID.	Reset the node numbers (MAC IDs) to eliminate duplication and restart the PT.
CompoBus/D I/F Unit Installation Error Exponent I/F connection error occurs.	An Expansion Interface Unit is not installed.	Check the DeviceNet Interface Unit's installation and restart the PT.
	An unsupported Unit is installed.	Check if the DeviceNet Interface Unit is installed and restart the PT.
CompoBus/D I/F Unit Hardware Error Expansion I/F Unit is broken.	---	Restart the PT. Replace the DeviceNet Interface Unit if the error recurs.

## 8-2 Troubleshooting with the LED Indicators

### 8-2-1 Meaning of the LED Indicators

The DeviceNet Interface Unit has 2 two-color (red or green) LED indicators.

MS (Module Status) LED: Indicates the PT's status as a Slave.

NS (Network Status) LED: Indicates the status of the network.

The following table shows the functions of the LED indicators. The color and status of the MS and NS indicators can be used to troubleshoot errors.

LED	Name	Color	Status	Indicated condition	Meaning
MS	Module status	Green	Lit	Normal status	Normal Unit condition
			Flashing	Not set yet	Switch settings are being read.
		Red	Lit	Fatal error	Unit hardware error (Watchdog Timer error)
			Flashing	Non-fatal error	Minor error such as incorrect switch settings
		---	Not lit	No power being supplied	<ul style="list-style-type: none"> <li>• Power is not being supplied to Slave Units.</li> <li>• Waiting for initialization to start.</li> <li>• Unit is being reset.</li> </ul>
NS	Network status	Green	Lit	Online, communications established	Normal network condition (communications established)
			Flashing	Online, communications not established	Normal network condition but communications are not established
		Red	Lit	Fatal communications error	Communications error (The Unit detected an error which makes communications through the network impossible.) <ul style="list-style-type: none"> <li>• Node number duplication</li> <li>• Bus off detected</li> <li>• Network power supply error</li> </ul>
			Flashing	Non-fatal communications error	Communications timeout
		---	Not lit	Offline or power supply OFF	<ul style="list-style-type: none"> <li>• Waiting for completion of the Master's node number duplication check</li> <li>• Incorrect switch settings (such as an incorrect communications speed setting)</li> <li>• Faulty network communications cable</li> <li>• Power supply OFF</li> </ul>

### 8-2-2 Identifying and Correcting Errors in Slaves

MS LED	NS LED	Meaning		Remarks
Lit (green)	Lit (green)	Remote I/O communications or message communications in progress	Remote I/O communications in progress or message communications being executed	Remote I/O communications, message communications, or both are being executed. Indicates normal communications status.
Lit (green)	Not lit	Checking for node number duplication	Waiting for the Master's node number duplication check	When the local Slave (PT) is the only Slave in this status, check the communications speed setting and restart the PT.
Lit (green)	Flashing (green)	Waiting to connect	Waiting for connection to be established from the Master	---
Lit (red)	Not lit	Watchdog timer error	A watchdog timer error occurred at the Slave.	Replace the Slave (DeviceNet Interface Unit).
Flashing (red)	Not lit	Incorrect switch settings	Incorrect switch settings such as the DIP switch	Check the DeviceNet memory switch settings and restart the PT.
Lit (green)	Lit (red)	Node number duplication	A node number is duplicated with the Master Unit.	Reset the node numbers to eliminate duplication and restart the Slave.
Lit (green)	Lit (red)	Busoff detected	Bus Off status (communications stopped due to multiple data errors)	Check the following points and restart the Slave (PT). <ul style="list-style-type: none"> <li>• Are the Master and Slave (DeviceNet Interface Unit) communications speeds the same?</li> <li>• Are the cable lengths (trunk and branches) within specifications?</li> <li>• Are any cables disconnected, damaged, or loose?</li> <li>• Are termination resistors connected only at each end of the trunk line?</li> <li>• Is noise excessive?</li> </ul>
Lit (green)	Flashing (red)	Communications timeout	---	Check the following points and restart the Slave (PT). <ul style="list-style-type: none"> <li>• Are the Master and Slave (DeviceNet Interface Unit) communications speeds the same?</li> <li>• Are the cable lengths (trunk and branches) within specifications?</li> <li>• Are any cables disconnected, damaged, or loose?</li> <li>• Are termination resistors connected only at each end of the trunk line?</li> <li>• Is noise excessive?</li> </ul>

# Appendix A

## Device Protocol

General data	Compatible DeviceNet specifications	Volume I-Release 1.3 Volume II-Release 1.3	---
	Vendor name	OMRON Corporation	Vendor ID = 47
	Device profile name	Slave: Human Machine Interface	Profile number = 18
	Product catalog number	V066	---
	Product revision	1.0	---
Physical conformance data	Network current consumption	50 mA max. at 24 VDC	---
	Connector type	Open plug	---
	Physical layer insulation	Yes	---
	Supported LEDs	Module Network	---
	MAC ID setting	Touch switch (system menu)	---
	Default MAC ID	0	---
	Transfer baud rate setting	Touch switch (system menu)	---
	Supported transfer baud rates	125 kbps, 250 kbps, and 500 kbps	---
Communications data	Predefined Master/Slave connection set	Group 2 only server	---
	Dynamic connection support (UCMM)	No	---
	Explicit message fragmentation support	Yes	---

## Object Mounting

### Identity Object (0x01)

Object class	Attribute	Not supported
	Service	Not supported

Item	ID content	Get (read)	Set (write)	Value
Object instance	Attribute			
	1 Vendor	Yes	No	47
	2 Product type	Yes	No	18
	3 Product code	Yes	No	54
	4 Revision	Yes	No	1.0
	5 Status (bits supported)	Yes	No	bit 0 only
	6 Serial number	Yes	No	Unique for each Unit
7 Product name	Yes	No	NT-DRT21	

Item	DeviceNet service	Parameter option
Object instance	Service 05 Reset	No

### Message Router Object (0x02)

Object class	Attribute	Not supported
	Service	Not supported
Object instance	Attribute	Not supported
	Service	Not supported
Vendor specification addition	No	

## DeviceNet Object (0x03)

Object class	Attribute	Not supported
	Service	Not supported

Item	ID content	Get (read)	Set (write)	Value
Object instance	1 MAC ID	Yes	No	---
	2 Baud rate	Yes	No	---
	3 BOI	Yes	No	00 (hexadecimal)
	4 Bus Off counter	Yes	No	---
	5 Allocation information	Yes	No	---

Item	DeviceNet service	Parameter option
Object instance	0E Get_Attribute_Single	No
	4B Allocate_Master/Slave_Connection_Set	No
	4C Release_Master/Slave_Connection_Set	No

## Connection Object (0x05)

Object class	Attribute	Not supported
	Service	Not supported
	Max. number of active connections	1

Item	Section	Information	Max. number of instances
Object instance 1	Instance type	Explicit Message	1
	Production trigger	Cyclic	---
	Transport type	Server	
	Transport class	3	

Item	ID content	Get (read)	Set (write)	Value
Object instance 1	1 State	Yes	No	---
	2 Instance type	Yes	No	00 (hexadecimal)
	3 Transport class trigger	Yes	No	83 (hexadecimal)
	4 Produced connection ID	Yes	No	---
	5 Consumed connection ID	Yes	No	---
	6 Initial comm. characteristics	Yes	No	21 (hexadecimal)
	7 Produced connection size	Yes	No	F0 (hexadecimal)
	8 Consumed connection size	Yes	No	F0 (hexadecimal)
	9 Expected packet rate	Yes	Yes	---
	12 Watchdog time-out action	Yes	No	01
	13 Produced connection path length	Yes	No	00
	14 Produced connection path	Yes	No	---
	15 Consumed connection path length	Yes	No	00
	16 Consumed connection path	Yes	No	---
	17 Production inhibit time	Yes	No	00

Item	DeviceNet service	Parameter option
Object instance 1	05 Reset	No
	0E Get_Attribute_Single	No
	10 Set_Attribute_Single	No

Item	Section	Information	Max. number of instances
Object instance 2	Instance type	Polled I/O	1
	Production trigger	Cyclic	---
	Transport type	Server	
	Transport class	2	

Item	ID content	Get (read)	Set (write)	Value	
Object instance 2	Attribute	1 State	Yes	No	---
		2 Instance type	Yes	No	01 (hexadecimal)
		3 Transport class trigger	Yes	No	82 (hexadecimal)
		4 Produced connection ID	Yes	No	---
		5 Consumed connection ID	Yes	No	---
		6 Initial comm. characteristics	Yes	No	01 (hexadecimal)
		7 Produced connection size	Yes	No	(See note)
		8 Consumed connection size	Yes	No	(See note)
		9 Expected packet rate	Yes	Yes	---
		12 Watchdog time-out action	Yes	No	01
		13 Produced connection path length	Yes	No	00
		14 Produced connection path	Yes	No	00_00_00_00_00_00
		15 Consumed connection path length	Yes	No	00
		16 Consumed connection path	Yes	No	00_00_00_00_00_00
17 Production inhibit time	Yes	No	00		

Item	DeviceNet service	Parameter option	
Object instance 2	Service	05 Reset	No
		0E Get_Attribute_Single	No
		10 Set_Attribute_Single	No

**Note** The following table shows the settings for the sizes (number of bytes) of the input area and output area. The actual setting format is 2 bytes with the leftmost byte and rightmost byte (values shown in following table) reversed.

Attribute	Size	Value
Produced connection size	Input area: 0 to 64 bytes	00 to 40 (hexadecimal)
Consumed connection size	Output area: 0 to 64 bytes	00 to 40 (hexadecimal)

Item	Section	Information	Max. number of instances
Object instance 3	Instance type	Bit strobed I/O	1
	Production trigger	Cyclic	---
	Transport type	Server	
	Transport class	2	

Item		ID content	Get (read)	Set (write)	Value
Object instance 3	Attribute	1 State	Yes	No	---
		2 Instance type	Yes	No	01 (hexadecimal)
		3 Transport class trigger	Yes	No	82 (hexadecimal)
		4 Produced connection ID	Yes	No	---
		5 Consumed connection ID	Yes	No	---
		6 Initial comm. characteristics	Yes	No	01 (hexadecimal)
		7 Produced connection size	Yes	No	(See note)
		8 Consumed connection size	Yes	No	01 (hexadecimal)
		9 Expected packet rate	Yes	Yes	---
		12 Watchdog time-out action	Yes	No	01
		13 Produced connection path length	Yes	No	00
		14 Produced connection path	Yes	No	00_00_00_00_00_00
		15 Consumed connection path length	Yes	No	00
		16 Consumed connection path	Yes	No	00_00_00_00_00_00
		17 Production inhibit time	Yes	No	00

Item		DeviceNet service	Parameter option
Object instance 3	Service	05 Reset	No
		0E Get_Attribute_Single	No
		10 Set_Attribute_Single	No

**Note** The following table shows the settings for the input area size (number of bytes). The actual setting format is 2 bytes with the leftmost byte and rightmost byte (values shown in following table) reversed.

Attribute	Size	Value
Produced connection size	Input area: 0 to 64 bytes	00 to 40 (hexadecimal)

## PT Object (0x8A)

Object class	Attribute	Not supported
	Service	Not supported

Item		DeviceNet service	Parameter option
Object instance	Service	32 Block_String_Read	Logical Area Address
		33 Block_StringN_Read	Logical Area Address Length
		34 Block_String_Write	Logical Area Address
		35 Block_StringN_Write	Logical Area Address Length

## PT Control Object (0x8B)

Object class	Attribute	Not supported
	Service	Not supported

Item		ID content	Get (read)	Set (write)	Value
Object instance	Attribute	1 Display Number	Yes	Yes	---
		2 Memory Table Copy	Yes	Yes	---
		3 PT Control	Yes	Yes	---

Item		DeviceNet service	Parameter option
Object instance	Service	01 Get_Attribute_All	No
		02 Set_Attribute_All	No



**PT Status Object (0x8C)**

Object class	Attribute	Not supported
	Service	Not supported

Item		ID content	Get (read)	Set (write)	Value
Object instance	Attribute	1 Display Number	Yes	No	---
		2 Memory Table	Yes	No	---
		3 PT Status	Yes	No	---

Item		DeviceNet service	Parameter option
Object instance	Service	01 Get_Attribute_All	No

**Window Control Object (0x8D)**

Object class	Attribute	Not supported
	Service	Not supported

Item		ID content	Get (read)	Set (write)	Value
Object instance	Attribute	1 Display Number	Yes	Yes	---
		2 X Offset	Yes	Yes	---
		3 Y Offset	Yes	Yes	---

Item		DeviceNet service	Parameter option
Object instance	Service	01 Get_Attribute_All	No
		02 Set_Attribute_All	No

# Appendix B

## Comparison of System Program Functions

A PT with the DeviceNet Interface Unit installed will operate with the functions of a “-V1” version (system program version 2.1) of the PT regardless of the PT’s actual version. The functions that can actually be used in newer PTs will differ from the functions described in the PT’s manual when the DeviceNet Interface Unit’s system program is installed. Moreover, the manuals for the “-V1” PT versions describe the functions of system program version 2.0, so they do not cover the new functions added to system program version 2.1.

This appendix describes only the differences between the functions which can be used with version 2.1 and the contents of the manuals for the “-V1” and “-V2” PTs, so this appendix can be used as reference when creating screen data for the DeviceNet Interface Unit. Only the differences due to the system program version are described here. Refer to *1-5 Functions of the DeviceNet Interface Unit* for details on functional differences due to the DeviceNet Interface Unit’s specifications.

### Differences from System Program Version 2.0

The following table shows the differences between system program version 2.0 (described in the manuals for the “-V1” PTs) and system program version 2.1 (used with the DeviceNet Interface Unit).

Item	Ver. 2.0	Ver. 2.1 (used with the DeviceNet Interface Unit)
Indirect reference of images and libraries	Indirect referencing not supported	Indirect referencing supported
Number of fixed display elements that can be registered in the library	64 max.	65,535 max.
Max. number of message characters that can be displayed in the alarm list/history of an NT631/NT631C PT	40 characters max. (The actual number may be lower depending on the display method.)	40 characters max. (The max. is always 40 characters regardless of the display method.)

## Differences from System Program Version 3.0

The following table shows the differences between system program version 3.0 (described in the manuals for the “-V2” PTs) and system program version 2.1 (used with the DeviceNet Interface Unit).

Item	Ver. 2.1 (used with the DeviceNet Interface Unit)	Ver. 3.0
Accessible CS1-series data areas	There are limitations. Only the current bank of the EM Area can be accessed.	Access is expanded. The accessible CS1-series data areas include areas such as specific EM Area banks and Task Flags.
Calculation function	Not available. All calculations must be performed by the PC program.	Available. Arithmetic expressions set in advance with the Support Tool can be calculated in the PT. This function can significantly reduce the load on the PC program.
Interlock	Not available.	Operation of inputs can be enabled/disabled according to the status of specified PC bits (interlock bits.) The interlock function can be set for individual touch switches, numeral inputs, thumbwheel inputs, and character string inputs. This function can significantly reduce the load on the PC program.
Multiple rows of guide characters (labels)	Not allowed (1 row only.) Multiple rows can be displayed by combining fixed character strings.	Multiple rows of guide characters can be set. Up to 256 characters can be set.
ON/OFF switching guide characters (labels)	Not allowed (always the same whether ON or OFF.) Substituted by image libraries, etc.	Different character strings can be displayed when the lamp bit is ON and OFF.
Numeral and character-string displaying guide characters (labels)	Not allowed. Can be achieved by stacking numeral displays and character-string displays.	The specified memory table can be referenced and the numeral or character string can be displayed as guide characters.
Device Monitor function	Not available.	Available. The contents of PC words can be listed and PVs can be displayed or changed by touch-switch operations. It is also possible to specify and call a screen by its screen number while the PT is operating, just like the Programming Console function.
Screen data compatibility from NT30/NT620 PTs to NT31/NT631 PTs.	Major data revisions are required to convert screen data from the NT30/NT620 Series to the NT31/NT631 Series.	The NT30/620 compatible mode provides compatibility with the earlier NT30/620 PTs, such as insertion of image and library into the text displays or labels of lamps and touch switches. This mode greatly reduces the amount of screen data editing required to convert data from the NT30/NT620 Series to the NT31/NT631 Series.

# Appendix C

## Standard Models

### PTs

Model	Specifications
NT31-ST121(-EV□)	NT31 STN monochrome display, ivory
NT31-ST121B(-EV□)	NT31 STN monochrome display, black
NT31C-ST141(-EV□)	NT31C STN color display, ivory
NT31C-ST141B(-EV□)	NT31C STN color display, black
NT631-ST211(-EV□)	NT631 High-intensity EL display (yellow), ivory
NT631-ST211B(-EV□)	NT631 High-intensity EL display (yellow), black
NT631C-ST141(-EV□)	NT631C STN color display, ivory
NT631C-ST141B(-EV□)	NT631C STN color display, black
NT631C-ST151(-EV□)	NT631C High-intensity STN color display, ivory
NT631C-ST151B(-EV□)	NT631C High-intensity STN color display, black

**Note** The DeviceNet (CompoBus/D) Interface Unit can be used with any PT version by installing the Unit's system program, but the system program's functions are equivalent to the functions of "-V1" versions (system version 2.1.)

### DeviceNet (CompoBus/D) Configurators

Name	Model	Remarks
DeviceNet (CompoBus/D) Configurator	3G8F5-DRM21	ISA board version
	3G8E2-DRM21	PCMCIA card version

### Support Tools

Name	Model	Remarks
NT-series Support Tool	NT-ZJ3AT1-EV3	Ver. 3.2 (earlier versions cannot be used) Compatible with PC/AT personal computers For Windows 95/98/NT (English version) Floppy Disk
	NT-ZJCAT1-EV3	Ver. 3.2 (earlier versions cannot be used) Compatible with PC/AT personal computers For Windows 95/98/NT (English version) CD-ROM
	NT-ZJCAT1-EV4	Ver. 4.1 Compatible with PC/AT personal computers For Windows 95/98/NT (English version) CD-ROM

## Communications Cables

Model	Specifications	Manufacturer
DCA2-5C10	Thick cable, 5-wire, 100 m	OMRON
DCA1-5C10	Thin cable, 5-wire, 100 m	OMRON
TDN18-10G	Thick cable, 5-wire, 10 m	Showa Electric Wire & Cable (see note 1)
TDN18-30G	Thick cable, 5-wire, 30 m	Showa Electric Wire & Cable (see note 1)
TDN18-50G	Thick cable, 5-wire, 50 m	Showa Electric Wire & Cable (see note 1)
TDN18-100G	Thick cable, 5-wire, 100 m	Showa Electric Wire & Cable (see note 1)
TDN18-300G	Thick cable, 5-wire, 300 m	Showa Electric Wire & Cable (see note 1)
TDN18-500G	Thick cable, 5-wire, 500 m	Showa Electric Wire & Cable (see note 1)
TDN24-10G	Thin cable, 5-wire, 10 m	Showa Electric Wire & Cable (see note 1)
TDN24-30G	Thin cable, 5-wire, 30 m	Showa Electric Wire & Cable (see note 1)
TDN24-50G	Thin cable, 5-wire, 50 m	Showa Electric Wire & Cable (see note 1)
TDN24-100G	Thin cable, 5-wire, 100 m	Showa Electric Wire & Cable (see note 1)
TDN24-300G	Thin cable, 5-wire, 300 m	Showa Electric Wire & Cable (see note 1)
TDN24-500G	Thin cable, 5-wire, 500 m	Showa Electric Wire & Cable (see note 1)
1485C-P1-A50	Thick cable, 5-wire, 50 m	Allen-Bradley (see note 2)
1485C-P1-C150	Thin cable, 5-wire, 150 m	Allen-Bradley (see note 2)

- Note**
1. The specifications for cables made by Showa Electric Wire & Cable are identical to the OMRON cable specifications.
  2. The cables made by Allen-Bradley are stiffer than those made by OMRON and Showa Electric Wire & Cable. Be sure to perform wiring carefully.

## Connectors

Model	Specifications	Manufacturer
MSTB2.5/5-ST-5.08AU	Connector for node connections, without connector securing screws (Included with the DRT1-series)	Phoenix Contact Part number: 1752399 (see note)
XW4B-05C1-H1-D	Connector for T-branch Tap node connections, with connector securing screws (Included with the CVM1-DRM21-V1, C200HW-DRM21-V1, CQM1-DRM21, and DCN1)	OMRON
XW4B-05C4-T-D	Connector for multi-drop node connections, without connector securing screws	OMRON

## Screwdrivers for Connectors

Model	Specifications	Manufacturer
XW4Z-00C	Screwdriver for DeviceNet (CompoBus/D) connectors	OMRON

## Terminating Resistors

Model	Specifications	Manufacturer
DRS1-T	Terminal block Terminating Resistor, 121 $\Omega$	OMRON

- Note** There is a Terminating Resistor for T-branch Tap connections available in addition to the terminal block style Terminating Resistor listed in the table above.

## T-branch Taps

Model	Specifications	Manufacturer
DCN1-1C	Three connectors are included. (Can create one branch line when used in the trunk line.) A Terminating Resistor can be installed.	OMRON
DCN1-3C	Five connectors are included. (Can create three branch lines when used in the trunk line.) A Terminating Resistor can be installed.	OMRON

## Power Supply Branch Taps

Model	Name	Specifications	Manufacturer
DCN1-1P	Power Supply Branch Tap	Required when connecting two or more power supplies. Two connectors are attached and a terminating resistor is included.	OMRON
1485T-P2T5-T5	Power Supply Tap (see note)	Required when connecting two or more power supplies. A ground terminal is attached.	Allen-Bradley

## Internet Contacts

Company	Address
Allen-Bradley	<a href="http://www.ab.com">http://www.ab.com</a>
OMRON	<a href="http://www.omron.com">http://www.omron.com</a>
Phoenix Contact	<a href="http://www.phoenixcontact.com">http://www.phoenixcontact.com</a>

# Index

## A–B

applications, precautions, xiii  
bar code reader, settings, 59  
baud rate, maximum, 24  
branching patterns, 23

## C

cables, preparing communications cables, 45  
CMND instruction, for message communications, 87  
communications  
  checking communications with PT, 66  
  maximum distance, 24  
  power supplies, 22  
  preparations for, 18  
  sharing power supplies, 27  
communications cables, preparing, 45  
compatibility with DeviceNet devices, 2  
computer, computer operations, 54  
Configurator, outline of Configurator functions, 9  
Connection Object (0x05), 112  
connectors, removing and installing, 47

## D

device protocol, 111  
DeviceNet Object (0x03), 112  
display language, setting PT display language, 53  
drop line, 22  
  lengths, 25  
  total length, 26

## E

EC Directives, xvii  
error messages, 108  
error processing, 107  
explicit Message Communications, 2, 3, 5, 10, 99–105  
EXPLICIT MESSAGE SEND command, 85

## F

features, 2  
FINS command, EXPLICIT MESSAGE SEND, 85  
fixed allocation, 7, 8  
  with remote I/O communications, 76  
free allocation, 7  
  with remote I/O communications, 77  
functions, functions of the DeviceNet Interface Unit, 10

## G–I

grounding, 37  
Identity Object (0x01), 111  
Indicators, LED indicators, 44  
installation, 43  
  precautions, xiii  
IOWR instruction, for message communications, 91

## L

ladder program, sample program, 103  
language, setting PT display language, 53  
LED indicators, 44  
  and troubleshooting, 109

## M

Master Units  
  compatible Master Units, 7  
  using multiple Masters, 3  
Memory Link control, 2  
  contrast with regular Memory Link method, 11  
memory switches, initializing, 57  
Message Communications, 5, 83–105  
  *See also* explicit Message Communications  
Message Router Object (0x02), 111  
model numbers, 119  
mounting the Unit, 45  
MS indicator, 44  
multi-drop method, 23  
Multi-layer Networks, 3

## N

DeviceNet network, connecting to a DeviceNet network, 2

network

- connecting to a DeviceNet network, 2, 45
- designing, 21
- grounding the network, 37

network configuration, 22

network length, maximum, 24

noise, reducing noise, 38, 40

NS indicator, 44

## O–P

operating environment, precautions, xiii

operating procedures, 16

power supply, 40

- locating, 29
- sharing communications power supplies, 27
- using multiple power supplies, 36

precautions, xi

- applications, xiii
- general, xii
- operating environment, xiii
- safety, xii

program, sample program, 103

PT Control Object (0x8B), 114

PT Memory Read, explicit message, 99

PT Memory Write, explicit message, 101

PT Object (0x8A), 114

PT operations, 51

PT settings, 51

- checking, 64

PT Settings procedure, 16

PT Status Object (0x8C), 115

## R

remote I/O Communications, 2, 3, 4

remote I/O communications, 69–82

- overview, 70
- starting during operation, 20
- Support Tool settings, 72
- using fixed I/O allocations, 18
- using free I/O allocations, 19

routing tables, 87

## S

safety precautions. *See* precautions

serial port A settings, 59

specifications, communications specifications, 6

standard models, 119

surge suppressors, to reduce noise, 39

system configuration, 7–8, 20

System Menu, structure, 56

system program

- checking the version information, 67
- comparison of system program function, 117
- installing, 52

## T

T-branch Tap, connecting cables, 48

Terminating Resistor, 22

- connecting, 49
- location, 26
- T-branch Tap, 49
- Terminal Block, 49

thick cable

- combining with thin cable, 25
- voltage drop, 31

thin cable

- combining with thick cable, 25
- voltage drop, 31

troubleshooting, 107

trunk line, 22

## V–W

voltage drop, 30, 33

Window Control Object (0x8D), 115



## Revision History

A manual revision code appears as a suffix to the catalog number on the front cover of the manual.

Cat. No. V066-E1-1  
↑  
Revision code

The following table outlines the changes made to the manual during each revision. Page numbers refer to the previous version.

Revision code	Date	Revised content
1	August 2000	Original production