

Cat. No. Z150-E1-01

**V530-C300E  
2-Dimensional Code Reader  
V530-H301, V530-H302, or  
V530-H303 Scanner**

**OPERATION MANUAL**

**OMRON**

# OMRON

**Authorized Distributor:**

**V530-C300E**  
**2-Dimensional Code Reader**  
**V530-H301, V530-H302, or**  
**V530-H303 Scanner**  
**Operation Manual**

*Produced August 2001*

## Notice

OMRON products are manufactured for use according to proper procedures by a qualified operator and only for the purposes described in this manual.

The following conventions are used to indicate and classify precautions in this manual. Always heed the information provided with them. Failure to heed precautions can result in injury to people or damage to property.

 **DANGER** Indicates an imminently hazardous situation which, if not avoided, will result in death or serious injury.

 **WARNING** Indicates a potentially hazardous situation which, if not avoided, could result in death or serious injury.

 **Caution** Indicates a potentially hazardous situation which, if not avoided, may result in minor or moderate injury, or property damage.

## Visual Aids

The following headings will help you locate different types of information.

**Note** Indicates information of particular interest for efficient and convenient operation of the product.

→ Indicates pages where additional information can be found.

**1,2,3...** 1. Indicates a procedure. The step numbers in the procedure correspond to the numbers in any related illustrations.

## Screen Messages

In this manual, screen messages are given in bold/italic. E.g.: **Register**

## Trademarks

Windows 95, Windows 98, Windows Me, Windows 2000, and Windows NT are registered trademarks of Microsoft Corporation.

Hyper Terminal was developed by Hilgraeve Inc. of the US and is a registered trademark of Microsoft Corporation.

### © OMRON, 2001

All rights reserved. No part of this publication may be reproduced, stored in a retrieval system, or transmitted, in any form, or by any means, mechanical, electronic, photocopying, recording, or otherwise, without the prior written permission of OMRON.

No patent liability is assumed with respect to the use of the information contained herein. Moreover, because OMRON is constantly striving to improve its high-quality products, the information contained in this manual is subject to change without notice. Every precaution has been taken in the preparation of this manual. Nevertheless, OMRON assumes no responsibility for errors or omissions. Neither is any liability assumed for damages resulting from the use of the information contained in this publication.

# TABLE OF CONTENTS

<b>PRECAUTIONS</b> .....	<b>ix</b>
1 Safety Precautions .....	x
2 General Precautions .....	x
3 Installation Precautions .....	xi
4 Package Contents .....	xv
<b>SECTION 1</b>	
<b>Features</b> .....	<b>1</b>
1-1 Features .....	2
1-2 Overview of Operation .....	4
1-3 Trigger Inputs and Outputs .....	6
<b>SECTION 2</b>	
<b>Installation</b> .....	<b>7</b>
2-1 Component Names and Functions .....	8
2-2 Connections .....	10
2-3 Wiring Controller Power and Ground .....	11
2-4 Mounting the Controller .....	13
<b>SECTION 3</b>	
<b>Connecting Peripheral Devices</b> .....	<b>15</b>
3-1 RS-232C Specifications .....	16
3-2 Flow of Communications .....	18
3-3 Output Data Format .....	19
3-4 FCS Calculation .....	20
3-5 Connection Examples .....	21
3-6 Terminal Block Specifications .....	24
3-7 Timing Charts .....	26
<b>SECTION 4</b>	
<b>Basic Operational Flow</b> .....	<b>29</b>
4-1 Introduction .....	30
4-2 Basic Operations Using the DIP Switch .....	31
4-3 Basic Operations Using the Console .....	35

# TABLE OF CONTENTS

## SECTION 5

<b>Operation with the Console</b> .....	<b>45</b>
5-1 SET (Setting) Mode .....	46
5-2 RUN Mode .....	102
5-3 System Mode .....	107
5-4 Tool Mode .....	113
5-5 Scenes .....	117
5-6 Saving to Flash Memory .....	120

## SECTION 6

<b>Command Input and Output Formats</b> .....	<b>123</b>
6-1 Output Format .....	124
6-2 Commands .....	124
6-3 Error Codes .....	125

## SECTION 7

<b>Regular Inspections</b> .....	<b>149</b>
----------------------------------	------------

## SECTION 8

<b>Specifications and Dimensions</b> .....	<b>151</b>
8-1 2-Dimensional Code Reader .....	152
8-2 Cables .....	157
8-3 Console .....	158
8-4 Monitors .....	159

## SECTION 9

<b>Troubleshooting</b> .....	<b>163</b>
9-1 Problems Reading Codes .....	164
9-2 Error Codes and Countermeasures .....	166
9-3 Troubleshooting .....	171

## Appendices

A ASCII Codes .....	175
B FCS Check Program Examples (BASIC) .....	177
C Data Capacity Tables .....	179
D Glossary .....	181

<b>Index</b> .....	<b>185</b>
--------------------	------------

<b>Revision History</b> .....	<b>189</b>
-------------------------------	------------

# ***About this Manual:***

This manual describes the features, specifications and operation of a 2-Dimensional Code Reader consisting of a the V530-C300E Controller and V530-H30□ Scanner and includes the following sections.

**Section 1** gives an overview of the features and operation of the 2-Dimensional Code Reader.

**Section 2** describes the parts of the 2-Dimensional Code Reader and details the connections and other procedures necessary for installation.

**Section 3** provides information required to connect to and communicate with an external device.

**Section 4** gives an overview the operation of the 2-Dimensional Code Reader.

**Section 5** describes the procedures required to operate the 2-Dimensional Code Reader from the Console.

**Section 6** describes the formats used to input commands and output reading data.

**Section 7** gives basic maintenance procedures and inspection items for the 2-Dimensional Code Reader.

**Section 8** gives specifications and dimensions for the components of the 2-Dimensional Code Reader.

**Section 9** details errors that may occur with the 2-Dimensional Code Reader and gives procedures for dealing with those errors.

The Appendices provide ASCII codes, examples of FCS check programs, data capacity tables, and a glossary of terms.



**WARNING** Failure to read and understand the information provided in this manual may result in personal injury or death, damage to the product, or product failure. Please read each section in its entirety and be sure you understand the information provided in the section and related sections before attempting any of the procedures or operations given.





# PRECAUTIONS

This section provides general precautions for using a 2-Dimensional Code Reader consisting of a the V530-C300E Controller and V530-H30□ Scanner.

**The information contained in this section is important for the safe and reliable application of the V530-C300E/V530-H30□ 2-Dimensional Code Reader. You must read this section and understand the information contained before attempting to set up or operate a V530-C300E/V530-H30□ 2-Dimensional Code Reader.**

1	Safety Precautions . . . . .	x
2	General Precautions . . . . .	x
3	Installation Precautions . . . . .	xi
4	Package Contents . . . . .	xv

# 1 Safety Precautions

The following must be followed to ensure the safety.

- Do not use the V530-C300E or V530-H30□ in environments with flammable or explosive gases.
- Install the V530-C300E or V530-H30□ away from high-voltage equipment or motors to ensure safety during operation and maintenance.
- Use crimp terminals for wiring. Do not connect bare stranded wires directly to terminals.
- Use DC power supplies with safe extra low-voltage circuits for the main V530-C300E power supply and terminal block power supplies in order to prevent an occurrence of high voltages.
- Use the power supply cables and crimp terminals of specified sizes.
- Use at the power supply voltages specified in this manual.
- Double-check all wiring and switch settings before turning ON the power supply.
- Do not dismantle, repair or modify any V530-C300E components.
- Dispose of V530-C300E components as industrial waste.
- To prevent damage from static electricity, use a wrist strap or another device for preventing electrostatic charges when touching terminals or signal line.
- Do not allow foreign materials, including metal objects or liquids, to enter the opening on the Controller or the Scanner.
- Do not turn OFF the power supply for 30 seconds after turning ON the power supply. Data in memory may be destroyed, possibly preventing correct operation in the future. (The buzzer on the Scanner may sound or the OK indicator or illumination may light for 30 seconds after power is turned back ON, but this does not indicate a malfunction.)

# 2 General Precautions

The user must operate the product according to the performance specifications described in the operation manuals.

Before using the product under conditions which are not described in the manual or applying the product to unclear control systems, railroad systems, aviation systems, vehicles, combustion systems, medical equipment, amusement machines, safety equipment, and other systems, machines, and equipment that may have a serious influence on lives and property if used improperly, consult your OMRON representative.

Make sure that the ratings and performance characteristics of the product are sufficient for the systems, machines, and equipment, and be sure to provide the systems, machines, and equipment with double safety mechanisms.

## **3 Installation Precautions**

The V530-C300E or V530-H30□ is highly reliable and resistant to most environmental factors. The following guidelines, however, must be followed to ensure reliability and optimum use of the V530-C300E.

### **Components**

Be sure to use the Scanner, Scanner Cable, and Console designed for the V530-C300E.

- V530-H30□ Scanner
- V530-W001 Scanner Cable
- F150-KP Console

### **Installation Site**

Do not install the V530-C300E or V530-H30□ in locations subject to the following conditions.

- Ambient temperatures outside of 0 to 50°C for the Controller, 0 to 38°C for the Scanner, or 0 to 40°C for the recommended Video Monitor (F150-M09).
- Condensation due to rapid temperature fluctuations
- Relative humidities outside 35% to 85%
- Corrosive or flammable gases
- Dust, salt, or iron particles
- Direct vibration or shock
- Direct sunlight
- Water, oil, or chemical fumes or spray

## **Installation**

### **Orientation of Controller**

To improve heat dissipation, install the controller in the following orientation only:

**CORRECT**

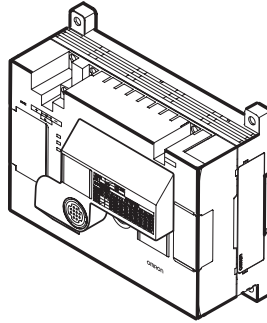

Do not install the controller in the orientations shown in the following diagram.

**INCORRECT**

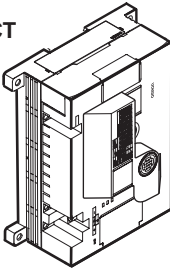

**INCORRECT**

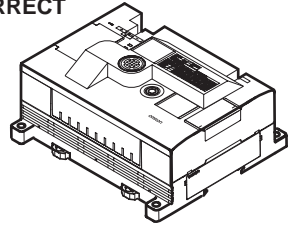

### **Ambient Temperature**

- Maintain a minimum clearance of 50mm above and below V530-C300E components to improve air circulation.
- Do not install V530-C300E components immediately above strong heat sources, such as heaters, transformers, or large-capacity resistors.
- Do not let the ambient operating temperature exceed 50°C for the Controller or 38°C for the Scanner.

- Provide a forced-air fan or air conditioning if the ambient temperature of the Controller might exceed 50°C.

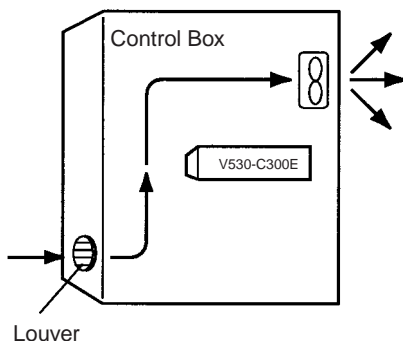

### Noise Resistance

Use the following measures to help increase noise resistance.

- Do not install V530-C300E components in a cabinet containing high-voltage equipment.
- Do not install V530-C300E components within 200 mm of power cables.

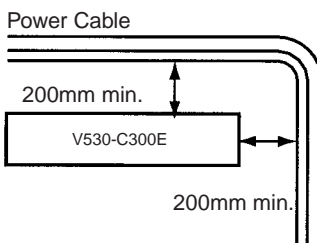

### Cables

- Always turn OFF the power before connecting or disconnecting cables.
- Do not remove the core connected to the Scanner Cable (V530-W001).
- Do not lay cables with power cables to reduce the possibility of noise affecting operation.
- Install cables well away from motors, arc welders, electromagnetic switches, and other possible sources of noise.
- Lay cables so that they are not repetitively bent at the cable connector.

**Scanner**

- We recommend holding the Scanner as shown below.

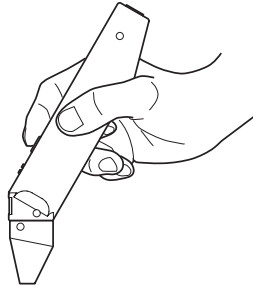

- Do not apply excessive force to the Scanner.
- Do not pull on the cable.

**V530-H303 Scanner**

- The thickness of glass being read must be 1 mm or less.
- The distance of the center of the code from the edge of the glass is 7 mm, 10 mm, or 13mm.
- To change the distance, loosen the two screws on the reading section, adjust the stopped to the desired position, and then retighten the screws. The screws are M2 x 4 pan-head tapping screws.
- The field of vision is 6 mm. Adjust the above stopped according to the size and position of the code.

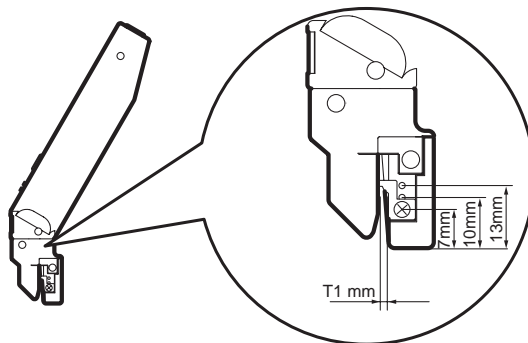

Screws: Pan-head tapping  
screws, M2 x 4

## **Installing the Video Monitor**

This precaution applies to using the recommended Video Monitor (F150-M09). The case of the Video Monitor is connected to the 0-V line of the internal circuits. Observe the following precautions to prevent noise penetration if the case is made of metal.

- Do not ground the Video Monitor.
- Do not ground the metal portion of the connector.
- If the Video Monitor is installed on a metal surface, secure it with plastic.

## **2-Dimensional Code**

- The blank margin (quiet zone) is necessary around 2-dimensional codes. Four cells are required for Data Matrix and QR Code.
- Set the code size so that only one code is picked up. Reading cannot be performed correctly if more than one code is on the screen.

## **Regulations and Standards**

The V530-C300E complies with the EC Directive and EN standards listed below.

- EC Directive  
EMC Directive: No. 89/336/EEC
- EN Standards (European Standards)  
EN61326: 1997/Annex A+A1: 1998 (EMI: Class A),  
EN61000-6-2: 1999, EN50081-2: 1993

# **4 Package Contents**

## **Confirming Package Contents**

Check the contents of the package as soon as you receive the V530-C300E.

Contact the nearest OMRON representative if any of the following items are missing.

- V530-C300E 2-Dimensional Code Reader Controller
- Operation Manual (this manual)





# SECTION 1

## Features

This section gives an overview of the features and operation of the 2-Dimensional Code Reader.

1-1	Features .....	2
1-2	Overview of Operation .....	4
1-3	Trigger Inputs and Outputs .....	6

# 1-1 Features

## 1. Reads Minute 2-Dimensional Direct Marking Codes

- Three models of Scanner are available.
- Select the Scanner according to the workpiece.

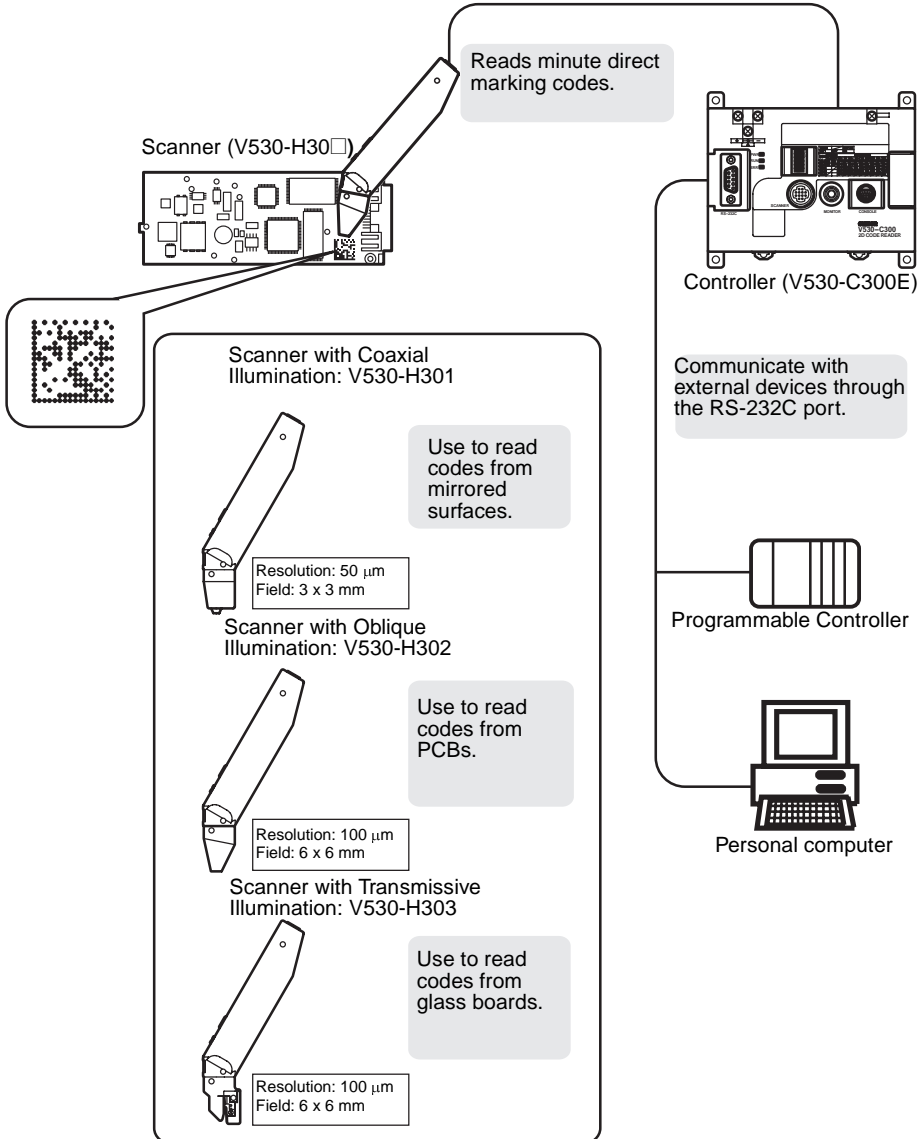

**Reads QR Codes or Data Matrix**

<b>Code</b>	QR code (model 1 or 2)	Data matrix (ECC200)
<b>Applicable size</b>	Versions 1 to 6	10 x 10 to 26 x 26
<b>Reading direction</b>	360°	360°

**2. Detailed Settings for the Workpiece**

- Operation is possible from a Console.

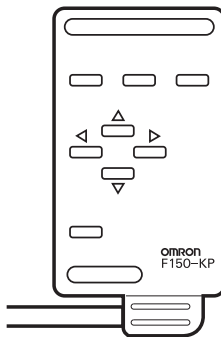

**3. Monitor 2-Dimension Code Markings on a Monitor**

- A monitor can be connected to monitoring the status of reading.

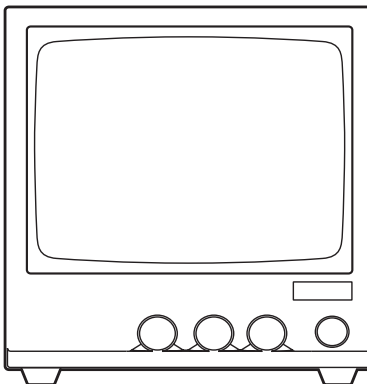

# 1-2 Overview of Operation

The Controller can be set either by using a DIP switch on the Controller or by using a Console. This section describes operation using the DIP switch.

1. Connect the Controller and Scanner and wire the power supply.

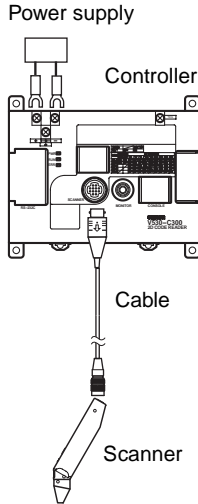

Refer to *Section 2 Installation*.

2. Connect any required external device.

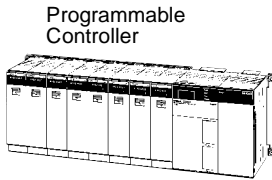

Personal computer

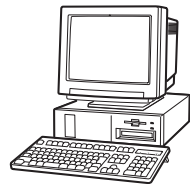

Refer to *Section 3 Connecting Peripheral Devices*.

3. Turn ON the power supply, wait for 30 seconds, and then set reading conditions. Set SW2 to SW6 on the DIP switch according to the code being read.

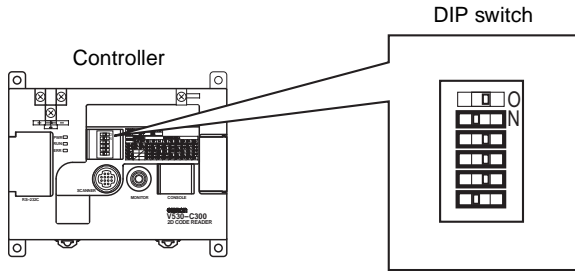

Refer to 4-2 Basic Operations Using the DIP Switch.

4. Perform teaching by turning ON SW1 on the DIP switch and reading the code on a workpiece. Teaching will be performed automatically.

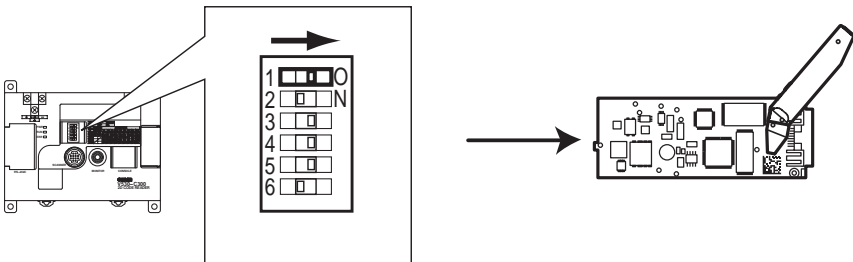

Refer to 4-2 Basic Operations Using the DIP Switch.

5. Turn OFF SW1 on the DIP switch and the read codes from workpieces.

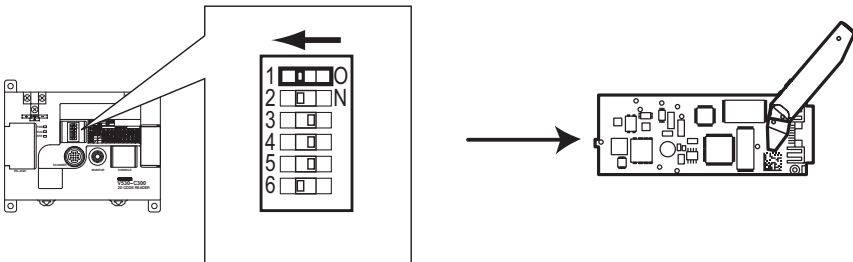

Refer to 4-2 Basic Operations Using the DIP Switch.

# 1-3 Trigger Inputs and Outputs

## Trigger Inputs

- Trigger Inputs from the Scanner  
Press the Trigger Switch on the Scanner to read a code.

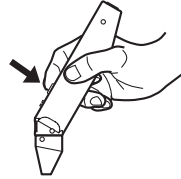

- Trigger Inputs from the Console  
Press the TRIG Key on the Console to read a code.
- Trigger Inputs from RS-232C Port  
Reading can be triggered from the RS-232C port for either normal reading or continuous reading.
- Trigger Input from Terminal Block  
A level trigger can be input.



## Reading Result Outputs

- To RS-232C →page 19  
Reading result and data are output.

# SECTION 2

## Installation

This section describes the parts of the 2-Dimensional Code Reader and details the connections and other procedures necessary for installation.

2-1	Component Names and Functions . . . . .	8
2-2	Connections . . . . .	10
2-3	Wiring Controller Power and Ground . . .	11
2-3-1	Crimp Terminals and Cables . . . . .	11
2-3-2	Protective Conductor (Earth) Wiring	11
2-3-3	Wiring the Power Supply . . . . .	12
2-4	Mounting the Controller . . . . .	13
2-4-1	Mounting to DIN Track . . . . .	13
2-4-2	Mounting on a Flat Surface . . . . .	14

# 2-1 Component Names and Functions

The following diagram shows the terminals, connectors, and indicators on the 2-Dimensional Code Reader.

## Controller

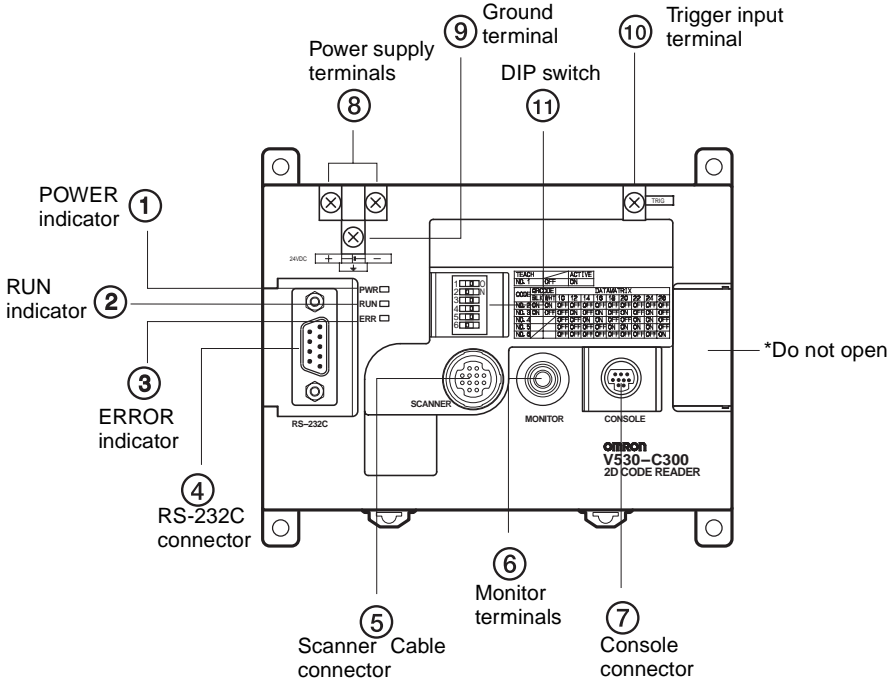

- ① Lit while power is ON.
- ② Lit in RUN mode.
- ③ Lit when an error occurs.
- ④ Connects the V530-C300E to a computer, Programmable Controller, or other external device.
- ⑤ Connects to the Scanner.
- ⑥ Connects to the monitor.
- ⑦ Connects to the Console.
- ⑧ Wired to the power supply.
- ⑨ Wired to a ground.
- ⑩ Connects to an external device to input a trigger.
- ⑪ Set according to code being read.



Scanner

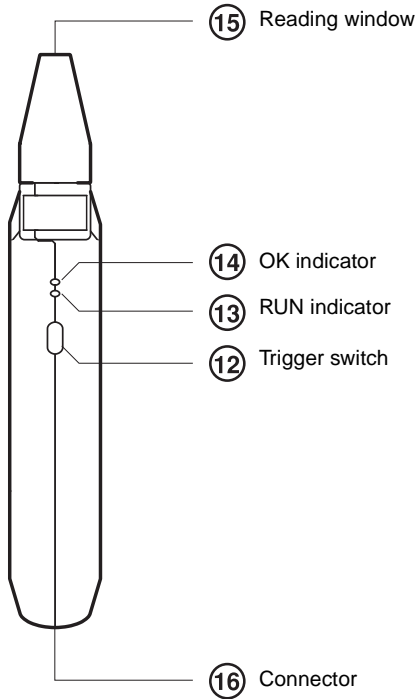

- ⑫ Inputs a trigger to read a code.
- ⑬ Lit in RUN mode.
- ⑭ Lit when it's okay to read. (Remains lit until the next trigger is received.)
- ⑮ Move close to the code being read.
- ⑯ Connect the Scanner Cable.

**Note** The RUN indicator will not light and the OK indicator will be unstable for 30 seconds after power is turned ON.

# 2-2 Connections

Connect the basic components.

Power supply

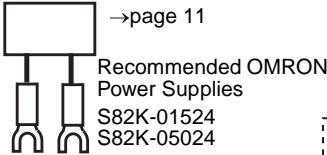

\*Products indicated with asterisks must be used. Other products cannot be substituted.

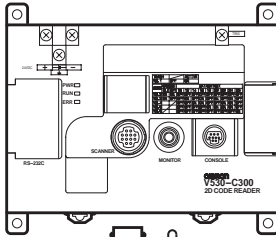

F150-KP Console (cable length: 2m)

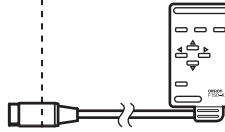

\*V530-W001 Scanner Cable (2 m)

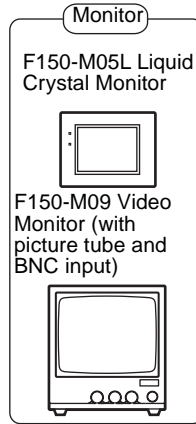
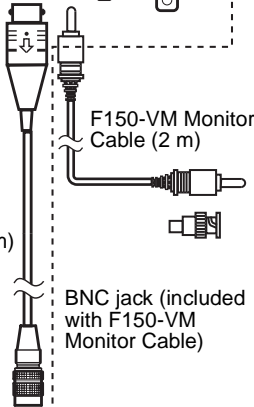

\*Scanners

Coaxial Illumination

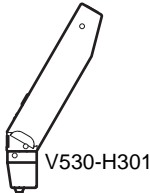

Oblique Illumination

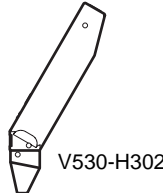

Transmissive Illumination

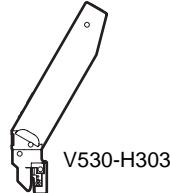



**Note** Turn OFF the power to the Controller before connecting or disconnecting cables. Connecting or disconnecting cables with power turned ON may damage peripheral devices.

## 2-3 Wiring Controller Power and Ground

Wire the power supply and the ground to the top terminal block, and tighten the screws to a torque of between 0.5 and 0.6 N•m. After wiring, check to make sure that the wiring is correct.

### 2-3-1 Crimp Terminals and Cables

The terminal block uses M3 terminal screws. Use appropriate crimp terminals for M3 screws, as shown below.

Terminal	Maker	Model No.	Wire size
Forked 	J.S.T. Mfg. Co., Ltd.	V1.25-N3A	1.31 to 1.65 mm <sup>2</sup> (AWG16 to AWG15)
Round 	J.S.T. Mfg. Co., Ltd.	V1.25-MS3	

### 2-3-2 Protective Conductor (Earth) Wiring

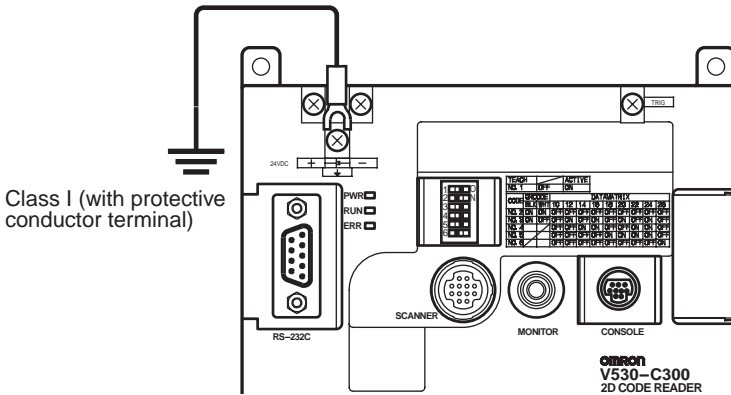

- Note**
1. Use an appropriate ground. An insufficient ground can affect V530-C300E operation or result in damage to V530-C300E components.
  2. To avoid damage to the equipment, do not share the protective conductor wiring with any other devices nor wire the protective conductor terminal to the girder. Be sure to wire the protective conductor of the equipment independently.
  3. Keep the ground line as short as possible.

### 2-3-3 Wiring the Power Supply

**Caution** Use a DC power supply with safe extra low-voltage circuits on the secondary side. Excessively high voltages can result in electric shock.

#### Power supply

Use a power supply with the following specifications. We recommend using OMRON's S82K-01524 Power Supply.

Output current	0.6 A min.
Power supply voltage	24 VDC+10%, -15%

Use a power supply with the following specifications when connecting the V530-C300E and F150-M05L LCD Monitor to one power supply. We recommend using OMRON's S82K-05024 Power Supply.

Output current	1.6 A min.
Power supply voltage	24 VDC+10%, -15%

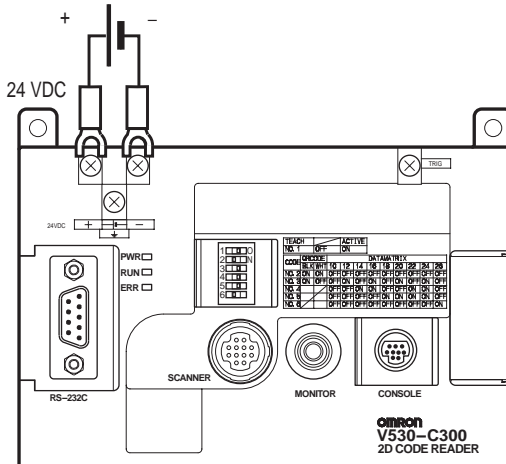

- Note**
1. Wire the Power Supply Unit independently of other devices. In particular, keep the power supply wired separately from inductive loads.
  2. Keep the power supply cable as short as possible (max.: 10 m).
  3. If UL recognition is required, use a UL class II power supply.

## 2-4 Mounting the Controller

The 2-Dimensional Code Reader can be mounted to DIN Track or a flat surface.

### 2-4-1 Mounting to DIN Track

The 2-Dimensional Code Reader can be easily mounted to or removed from 35-mm DIN Track.

The following DIN tracks are available from OMRON.  
PFP-100N (1 m)  
PFP-50N (50 cm)  
PFP-100N2 (1 m)

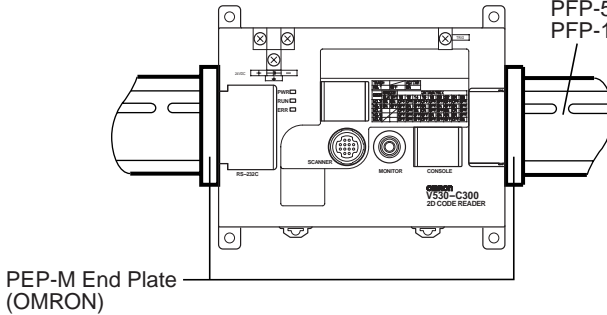

### Mounting the Controller

Hook the Controller into the DIN Track as shown in the diagram and then press in at the bottom until the Controller locks into place.

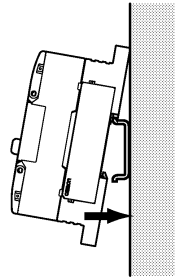

Removing the Controller

Use a screwdriver to pull the hook down and then pull out the Controller from the bottom.

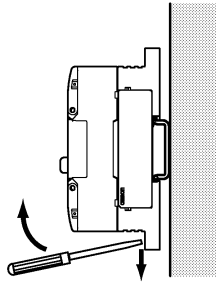

2-4-2 Mounting on a Flat Surface

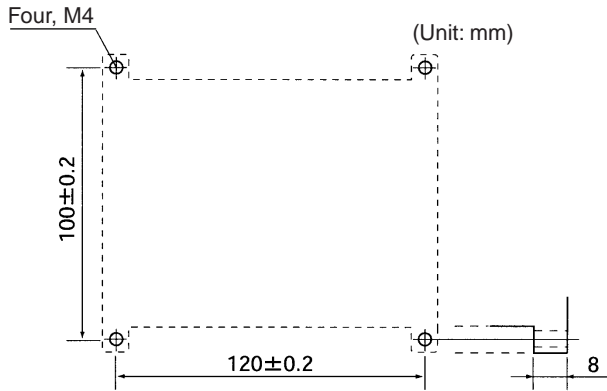

# SECTION 3

## Connecting Peripheral Devices

This section provides information required to connect to and communicate with an external device.

3-1	RS-232C Specifications . . . . .	16
3-1-1	Connector . . . . .	16
3-1-2	Wiring . . . . .	17
3-1-3	Connection . . . . .	18
3-2	Flow of Communications . . . . .	18
3-3	Output Data Format . . . . .	19
3-4	FCS Calculation . . . . .	20
3-5	Connection Examples. . . . .	21
3-5-1	Connecting to a Programmable Controller	21
3-5-2	Connecting to a Personal Computer	23
3-6	Terminal Block Specifications . . . . .	24
3-6-1	Terminal Name. . . . .	24
3-6-2	Crimp Terminals and Cables . . . . .	24
3-6-3	TRIG Terminal Specifications . . . . .	25
3-7	Timing Charts. . . . .	26
3-7-1	Reading Level Trigger . . . . .	26

## 3-1 RS-232C Specifications

### 3-1-1 Connector

The V530-C300E uses 9-pin D-SUB female connectors. The pin numbers and names are shown below.

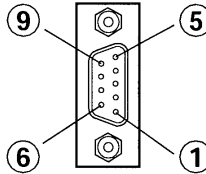

#### Recommended OMRON Connector

Model	Model No.
Plug	XM2A-0901
Hood	XM2S-0911

Pin	Signal	Name
1	FG (GND)	Frame ground
2	SD (TXD)	Send Data
3	RD (RXD)	Receive Data
4	RS (RTS)	Request to Send
5	CS (CTS)	Clear to Send
6	NC	Not connected
7	NC	Not connected
8	NC	Not connected
9	SG (GND)	Signal ground



### 3-1-2 Wiring

Only use a shielded RS-232C cable.

#### Standard Connections

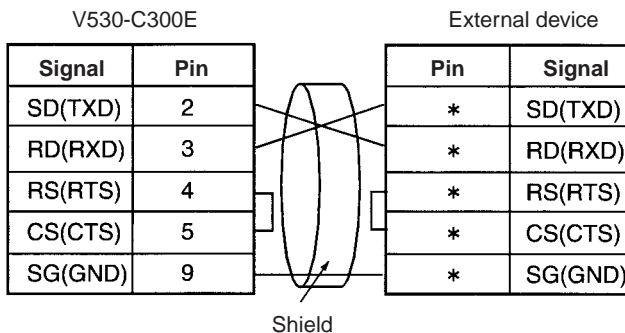

#### Connections for RS/CS Control

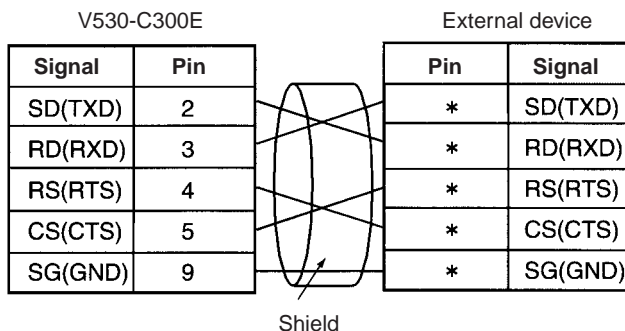

**Note** Pin numbers will depend on the external device being connected. Refer to the manual for the external device.

### 3-1-3 Connection

Align the connector with the socket and press the connector straight into place. Tighten the two screws on the edges of the connector.

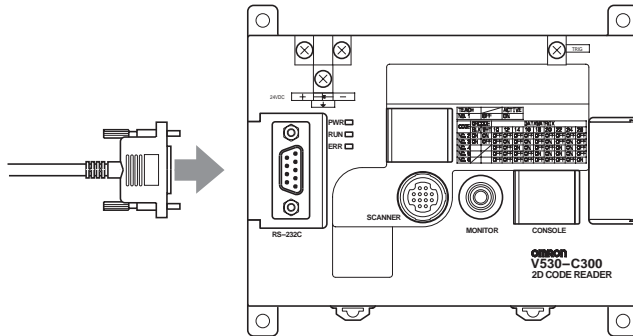

- Note**
1. Always turn OFF the power supply before connecting or disconnecting cables. Peripheral devices can be damaged if connected or disconnected with the power supply turned ON.
  2. Always tighten the connector screws.

## 3-2 Flow of Communications

No-protocol communications can be performed with a host device, such as a personal computer, through the RS-232C port.

### Inputting a Trigger from the Scanner's Trigger Switch

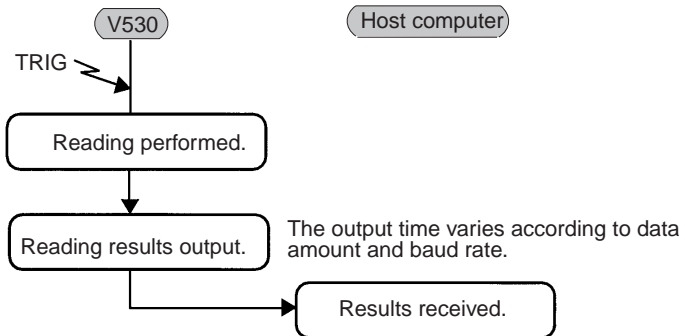

A timeout error occurs if there is no response from the host computer within the set time when RS/CS or Xon/off is selected for flow control.

Program example **page 22**

### 3-3 Output Data Format



Item	Setting
Header	Any of the following can be selected from the Console. The default is "none." <ul style="list-style-type: none"> <li>• None</li> <li>• STX</li> <li>• ESC</li> </ul>
FCS	Any of the following can be selected from the Console. The default is "OFF." <ul style="list-style-type: none"> <li>• OFF</li> <li>• ON</li> </ul>
Footer	Any of the following can be selected from the Console. The default is "CR." <ul style="list-style-type: none"> <li>• CR</li> <li>• LF</li> <li>• CR+LF</li> </ul>

**Note** Error outputs can be enabled or disabled via a setting. The default is "OFF" (disabled).

### 3-4 FCS Calculation

FCS (Frame Check Sequence) can be attached to output data to improve communications. FCS is the result of taking the XOR for each byte between header and footer (8 bits) and converting to 2-character ASCII codes.

Each time data is received, the host link calculates the FCS and checks it against the FCS attached to sending data so that sending data can be checked for errors. Refer to *Appendix B FCS Check Program Examples (BASIC)*, page 177

(e.g.) Reading data: ABCDEFG

The sending data is as shown below.

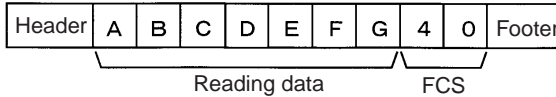

Calculation

	ASCII code				
A	41	0100	0001		
				XOR	
B	42	0100	0010		
				XOR	
C	43	0100	0011		
				XOR	
D	44	0100	0100		
				XOR	
E	45	0100	0101		
				XOR	
F	46	0100	0110		
				XOR	
G	47	0100	0111		
Result	0100	0000			



Converted into hexadecimal and used as ASCII codes.

### 3-5 Connection Examples

#### 3-5-1 Connecting to a Programmable Controller

##### System Configuration

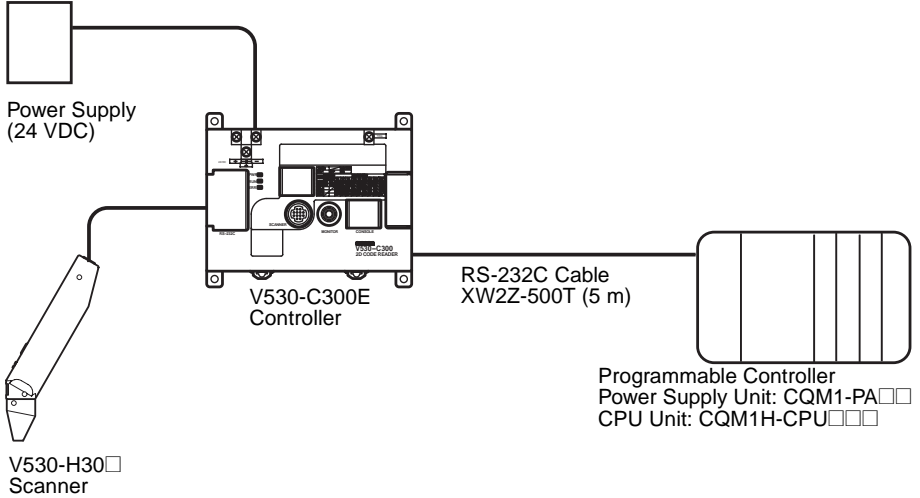

##### Cable Wiring

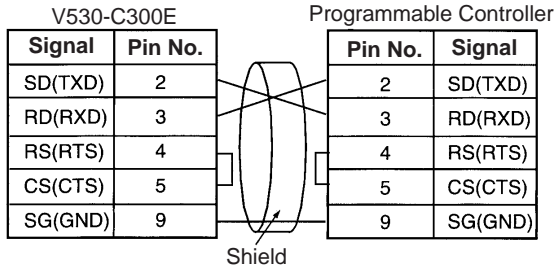

**Communication Settings**

- V530-C300E: page 107

Item	Setting
Baud rate	19200 bps
Data length	8 bits
Parity bits	Even
Stop bits	2 bits
Header	None
Footer	CR

- Programmable Controller:  
 Turn OFF the DIP switch of CQM1H.  
 Set DM 6645 to 1001, DM 6646 to 0904, DM 6648 to 1000 and DM 6649 to 0D00.  
 Match communication settings with the V530-C300E. Refer to the operation manual for CQM1H for the ways to change the setting.

**Program Example**

This is an example of a program in which a Programmable Controller (CQM1H) receives the data which is read at a V530-C300E.

**1,2,3...**

1. Set the reading conditions of the V530-C300E and set the reading mode to RUN mode.
2. The trigger switch or synchronous sensor of the scanner sends the reading trigger to the V530-C300E.  
 → The V530-C300E reads the code and outputs data.
3. The data received from the CQM1H is saved in order from the highest digit in DM 0200 from the first bit.

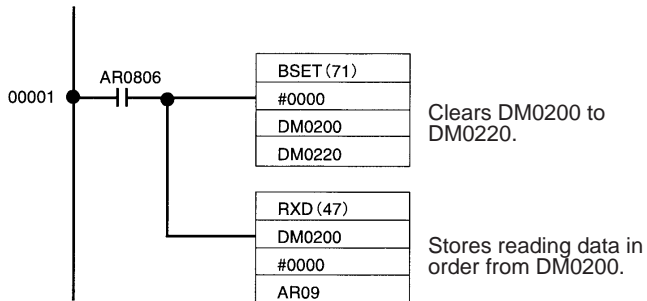

### 3-5-2 Connecting to a Personal Computer

#### System Configuration

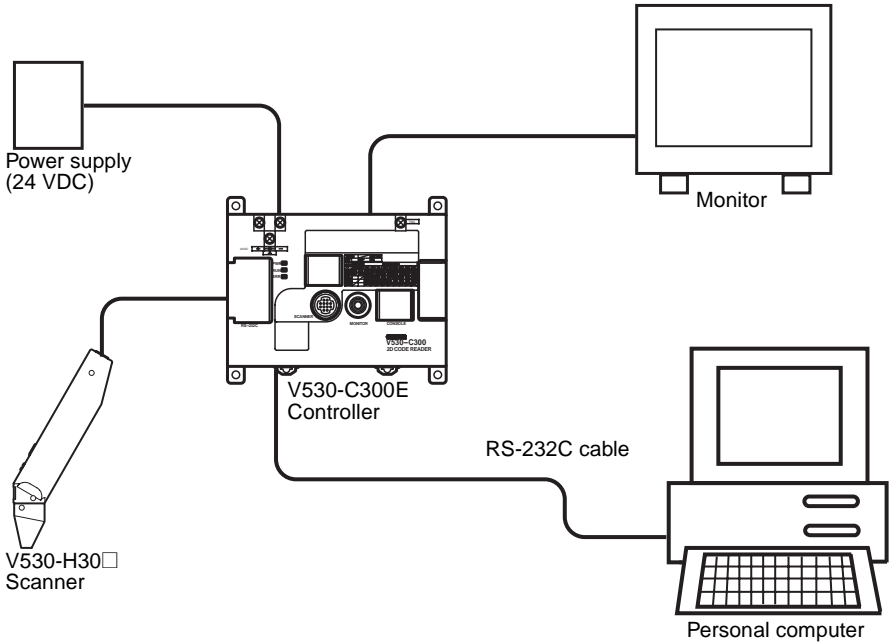

#### Cable Wiring

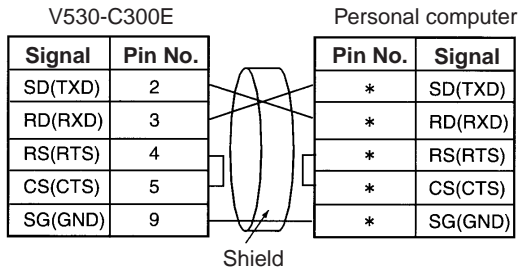

(\*) Pin numbers will depend on the type of personal computer connected. Refer to the manual of the personal computer.

#### Communication Settings

Match the communication settings (baud rate, data length, parity bits, and stop bits) of the personal computer and V530-C300E. Refer to **page 107**

**Program Example**

```

100 CLOSE #1
110 OPEN "COM:E73NN" AS #1 (OPEN communications port)
120 PRINT #1,"@GL"+CHR(&H0D) (Send single reading command)
130 INPUT #1,RESDATA$ (Load data; footer code:CR)
140 PRINT "READ DATA=";RESDATA$ (Display reading data)
150 GOTO 120 (Repeat)
160 END
    
```

**3-6 Terminal Block Specifications**

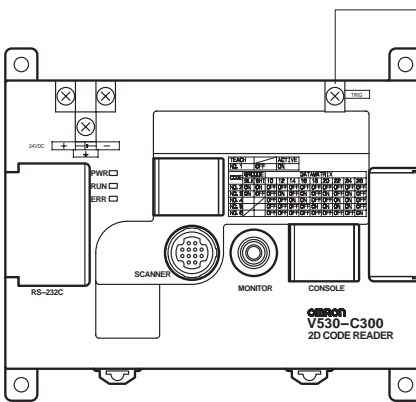

**3-6-1 Terminal Name**



TRIG Terminal (Level Trigger)  
 Reading will be repeated while the trigger is ON until a reading is successfully made. If reading was not completed successfully by the time the trigger goes OFF, a NG result is output.

**3-6-2 Crimp Terminals and Cables**

The terminal block uses M3 terminal screws. Use appropriate crimp terminals for M3 screws, as shown below. Tighten the screws to a torque of between 0.5 and 0.6 N•m. After wiring, check to make sure that the wiring is correct.

Terminal	Maker	Model No.	Wire size
Forked  6.2 mm max.	J.S.T. Mfg. Co., Ltd.	V1.25-N3A	1.31 to 1.65 mm <sup>2</sup> (AWG16 to AWG15)
Round  6.2 mm max.	J.S.T. Mfg. Co., Ltd.	V1.25-MS3	



**Caution** Cover the terminal blocks with the Terminal Block Protection Covers. Uncovered terminal blocks can result in electric shock.

### 3-6-3 TRIG Terminal Specifications

**Caution** Use a DC power supply with safe extra low-voltage circuits on the secondary side. Excessively high voltage can result in electric shock.

#### Input Specifications

ON current	5 to 15 mA
OFF current	0.1 mA max.
ON delay	RESET input: 10 ms max. Others: 0.5 ms max.
OFF delay	RESET input: 15 ms max. Others: 0.7 ms max.
Internal circuits	

**Note** If UL recognition is required, use a UL class II power supply.

# 3-7 Timing Charts

## 3-7-1 Reading Level Trigger

### OK Result (Readable)

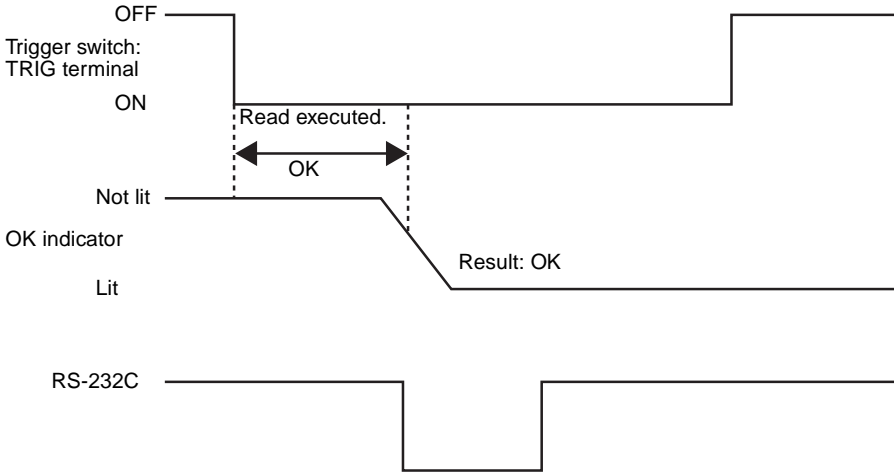

- Note**
1. The output time to RS-232C changes depending on the data volume or baud rate.
  2. The OK indicator will turn OFF when the next trigger is input or a through image is displayed.

### Input Terminals

Terminal	Function
TRIG	Continuous reading is performed when TRIG signal is turned ON.

**OK Result Obtained after Repeated Reading**

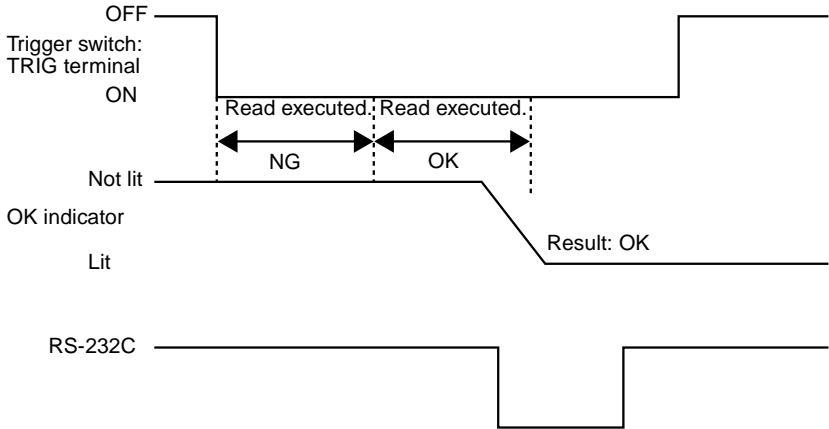

- Note**
1. The output time to RS-232C changes depending on the data volume or baud rate.
  2. The OK indicator will turn OFF when the next trigger is input or a through image is displayed.

**NG Result after Repeated Reading**

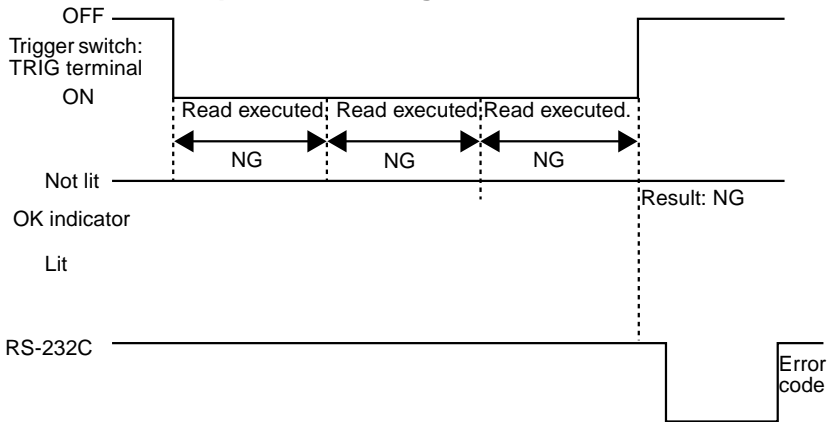

- Note**
1. The output time to RS-232C changes depending on the data volume or baud rate.
  2. The OK indicator will turn OFF when the next trigger is input or a through image is displayed.
  3. Error outputs can be enabled or disabled via a setting. The default is "OFF" (disabled).



# SECTION 4

## Basic Operational Flow

This section gives an overview the operation of the 2-Dimensional Code Reader.

4-1	Introduction . . . . .	30
4-2	Basic Operations Using the DIP Switch .	31
4-2-1	STEP 1: Starting . . . . .	31
4-2-2	STEP 2: Setting Reading Conditions	31
4-2-3	STEP 3: Perform Teaching . . . . .	33
4-2-4	STEP 4: Starting Reading . . . . .	34
4-3	Basic Operations Using the Console . . . .	35
4-3-1	STEP 1: Starting . . . . .	36
4-3-2	STEP 2: Setting Reading Conditions	37
4-3-3	STEP 3: Starting Code Reading. . . .	43

# 4-1 Introduction

There are two ways to teach the reading conditions: Using a DIP switch and using a Console. Monitor is required to teach using a Console.

**Note** Teaching is used to automatically set parameters based on the results of reading an actual code.

Using the DIP Switch (Refer to page 31.)

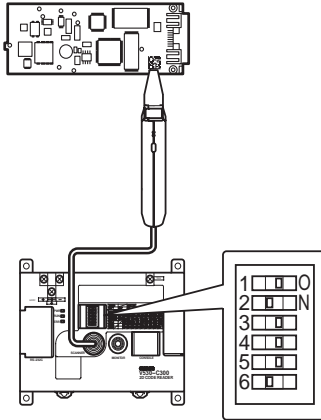

The DIP switch on the controller is set according to the code being read and a code is read by pressing the Trigger Switch on the Scanner. If reading is successful, the settings are automatically registered and saved in flash memory.

Using the Console (Refer to page 35.)

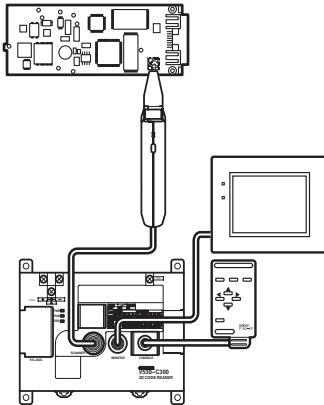

Settings are made using a Console and Monitor and a code is read by pressing the Trigger Switch on the Scanner. If reading is successful, the settings are automatically registered and saved in flash memory.

## 4-2 Basic Operations Using the DIP Switch

### 4-2-1 STEP 1: Starting

#### Procedure

- 1,2,3...
1. Be sure that the basic V530-C300E components have been connected correctly. **page 10**
  2. Turn ON the power supply to the V530-C300E. The RUN indicator will light.

**Caution** Do not turn OFF the power supply for 30 seconds after turning ON the power supply. Data in memory may be destroyed, possibly preventing correct operation in the future.

**Note** The buzzer on the Scanner may sound or the OK indicator or illumination may light for 30 seconds after power is turned back ON, but this does not indicate a malfunction.

### 4-2-2 STEP 2: Setting Reading Conditions

The DIP switch on the Controller is set according to the code being read.

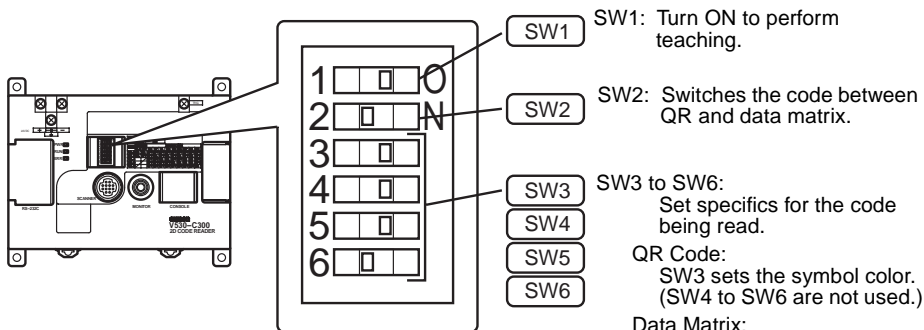

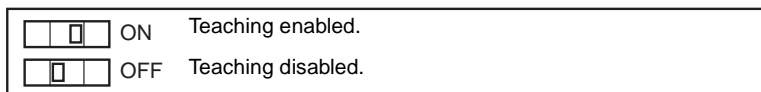

### DIP Switch Settings

#### SW1





SW2

<input type="checkbox"/> <input checked="" type="checkbox"/> <input type="checkbox"/>	ON	QR code is read.	
<input type="checkbox"/> <input type="checkbox"/> <input checked="" type="checkbox"/>	OFF	A data matrix is read.	

SW2 Turned ON (QR Code)

Set SW3 to the code color.

<input type="checkbox"/> <input checked="" type="checkbox"/> <input type="checkbox"/>	ON	A black code on a white background is read.	
<input type="checkbox"/> <input type="checkbox"/> <input checked="" type="checkbox"/>	OFF	A white code on a black background is read.	

**Note** SW4 to SW6 are not used when reading QR code. Leave SW4 to SW6 set to OFF.

SW2 Turned OFF (Data Matrix)

Set SW3 to SW6 to the matrix size to be read as shown below.

<input type="checkbox"/> <input type="checkbox"/> <input type="checkbox"/>	<input type="checkbox"/> <input type="checkbox"/> <input type="checkbox"/>	<input type="checkbox"/> <input type="checkbox"/> <input type="checkbox"/>	<input type="checkbox"/> <input type="checkbox"/> <input type="checkbox"/>	<input type="checkbox"/> <input type="checkbox"/> <input type="checkbox"/>
3 <input type="checkbox"/> <input type="checkbox"/>	3 <input type="checkbox"/> <input type="checkbox"/>	3 <input type="checkbox"/> <input type="checkbox"/>	3 <input type="checkbox"/> <input type="checkbox"/>	3 <input type="checkbox"/> <input type="checkbox"/>
4 <input type="checkbox"/> <input type="checkbox"/>	4 <input type="checkbox"/> <input type="checkbox"/>	4 <input type="checkbox"/> <input type="checkbox"/>	4 <input type="checkbox"/> <input type="checkbox"/>	4 <input type="checkbox"/> <input type="checkbox"/>
5 <input type="checkbox"/> <input type="checkbox"/>	5 <input type="checkbox"/> <input type="checkbox"/>	5 <input type="checkbox"/> <input type="checkbox"/>	5 <input type="checkbox"/> <input type="checkbox"/>	5 <input type="checkbox"/> <input type="checkbox"/>
6 <input type="checkbox"/> <input type="checkbox"/>	6 <input type="checkbox"/> <input type="checkbox"/>	6 <input type="checkbox"/> <input type="checkbox"/>	6 <input type="checkbox"/> <input type="checkbox"/>	6 <input type="checkbox"/> <input type="checkbox"/>
10 × 10	12 × 12	14 × 14	16 × 16	18 × 18
<input type="checkbox"/> <input type="checkbox"/> <input type="checkbox"/>	<input type="checkbox"/> <input type="checkbox"/> <input type="checkbox"/>	<input type="checkbox"/> <input type="checkbox"/> <input type="checkbox"/>	<input type="checkbox"/> <input type="checkbox"/> <input type="checkbox"/>	
3 <input type="checkbox"/> <input type="checkbox"/>	3 <input type="checkbox"/> <input type="checkbox"/>	3 <input type="checkbox"/> <input type="checkbox"/>	3 <input type="checkbox"/> <input type="checkbox"/>	
4 <input type="checkbox"/> <input type="checkbox"/>	4 <input type="checkbox"/> <input type="checkbox"/>	4 <input type="checkbox"/> <input type="checkbox"/>	4 <input type="checkbox"/> <input type="checkbox"/>	
5 <input type="checkbox"/> <input type="checkbox"/>	5 <input type="checkbox"/> <input type="checkbox"/>	5 <input type="checkbox"/> <input type="checkbox"/>	5 <input type="checkbox"/> <input type="checkbox"/>	
6 <input type="checkbox"/> <input type="checkbox"/>	6 <input type="checkbox"/> <input type="checkbox"/>	6 <input type="checkbox"/> <input type="checkbox"/>	6 <input type="checkbox"/> <input type="checkbox"/>	
20 × 20	22 × 22	24 × 24	26 × 26	



### 4-2-3 STEP 3: Perform Teaching

- 1,2,3... 1. Turn ON SW1 on the DIP switch. Teaching will be started.

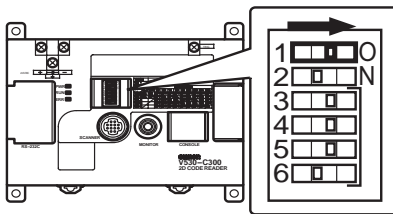

2. Align the reading window with the code and press the Trigger Switch on the Scanner.

If reading is successful, the OK indicator will light and the buzzer will sound. The parameters will be set according to the reading data. Parameters will not be set if reading is not successful. If necessary, try pressing the Trigger Switch again.

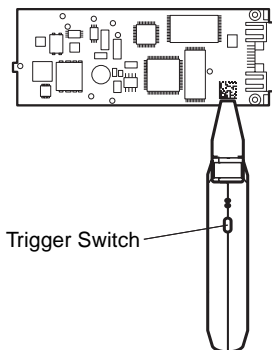

**Note** Reading will be performed continuously while the Trigger Switch is held down.

3. Turn OFF SW1 on the DIP switch to complete teaching.

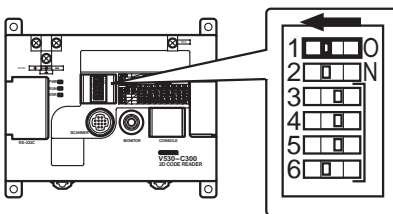

**Caution** Always turn OFF SW1 on the DIP switch after completing teaching. The teaching function will be enabled and will prevent normal operation if SW1 is ON.

**4-2-4 STEP 4: Starting Reading**

Reading can now be started and the reading result will be output to the external device through the RS-232C port.

**1,2,3...**

1. Confirm that the RUN indicator (orange) is lit.
2. Press the Trigger Switch on the Scanner to read a code. If reading is successful, the OK indicator (green) will light and the buzzer will sound.

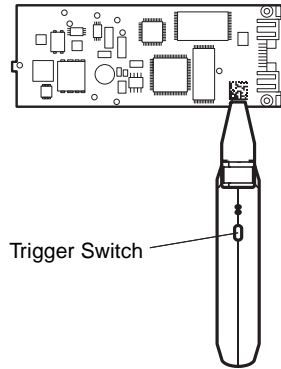
**Note**

1. Hold down the Trigger Switch until the reading is completed.
2. Repeat the teaching operation if reading cannot be completed successfully.
3. With the V530-H301 Scanner, hold the Scanner as close to the workpiece as possible.

### 4-3 Basic Operations Using the Console

The Console is used to perform menu operations displayed on a monitor. Be sure to familiarize yourself with Console operations before actually using the menus.

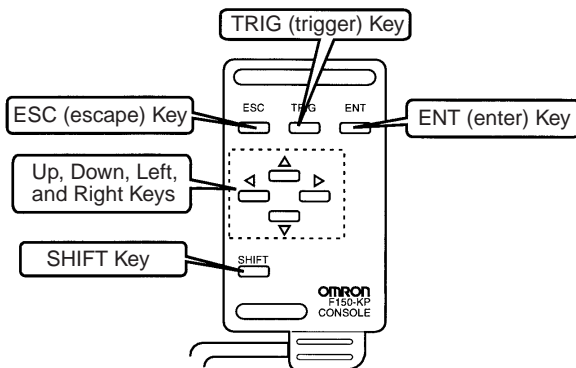

Key	Function
ESC	Interrupts processing and returns to the previous menu display.
TRIG	Starts code reading (One push → One reading)
ENT	Executes a function or sets a value.
▲/▼ (Up Key and Down Key)	Used to move the cursor up and down to select items. Also used to set values. The Up Key increases a value by 1 and the Down Key decreases a value by 1. Continue pressing the Up or Down Key to quickly increase or decrease a value.
◀/▶ (Left Key and Right Key)	Used to move the cursor left or right to select items.
SHIFT	Must be pressed in combination with another key to have any affect. Specific functions are assigned to Shift + another key for specific screens.

Screen Displays

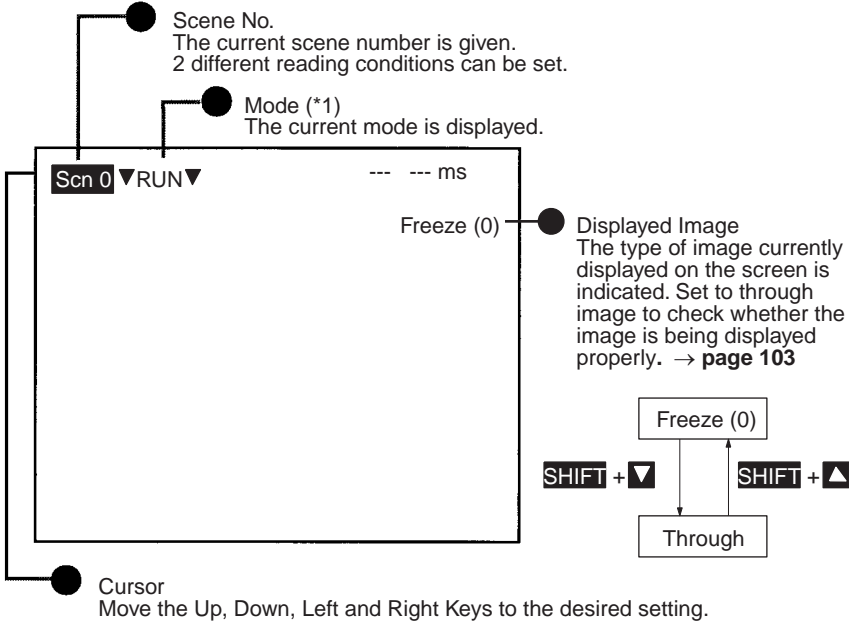

Mode (\*1)

Mode	Description
SET (Set)	Used to set reading conditions.
RUN (Run)	Used to read codes. The judgment is output to external devices through RS-232C.
SYS (System)	Used to set system conditions such as communications specifications.
TOOL (Tool)	Used to save and load settings for the system or scenes or image data through the RS-232C port connected to an external device.
SAVE (Save)	Used to save setting data to flash memory. Be sure to save and turn OFF power to the V530-C300E after changing the settings.

4-3-1 STEP 1: Starting

Procedure

- 1,2,3...
1. Be sure that the basic components have been connected correctly. **page 10**
  2. Turn ON the power supply to the monitor.
  3. Turn ON the power supply to the V530-C300E.

A startup message appears followed by a processing message. After a short pause, the initial screen appears. The following screen appears the first time power is turned ON.

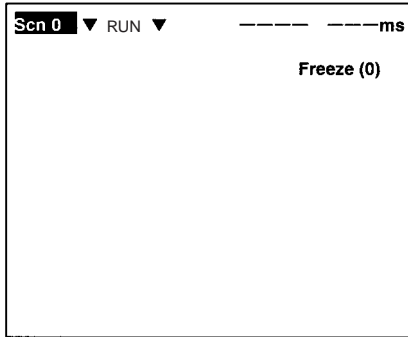

### 4-3-2 STEP 2: Setting Reading Conditions

**Note** This section only describes the necessary functions for basic operations. Other functions are described in *SECTION 5 Operation with the Console Functions and Operations*. Refer to page 45.

#### Procedure

- 1,2,3... 1. Move the cursor to **RUN** (Run) using the Right Key and press the ENT Key.

The mode selections are displayed.

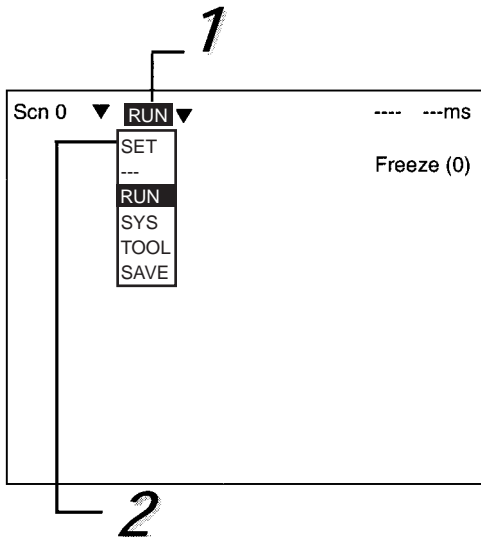

2. Move to **SET** using the Up Key and press the ENT Key.  
The following screen is displayed. The screen is in SET mode.

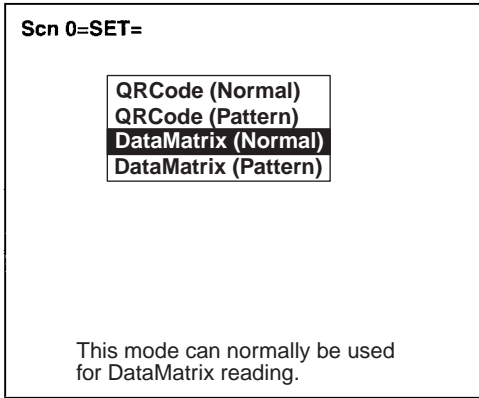

**Data Matrix Reading**

Select the required matrix size. The other reading conditions can be set using the teaching function. Using the teaching function, a reading is performed on the reading object and, based on this, parameters are set automatically.

3. Select **DataMatrix (Normal)** and press the ENT Key. The following screen will be displayed.

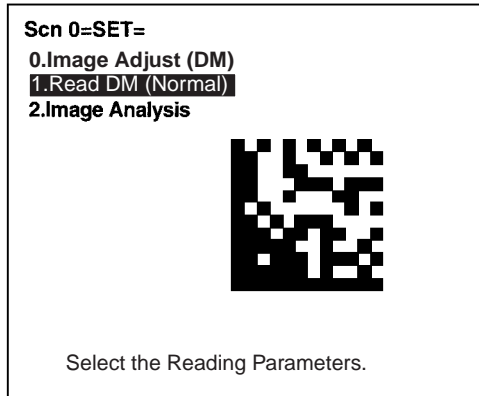

4. Select **1. Read DM (Normal)** and press the ENT Key.

5. Select **Reading Settings (Teaching)** and press the ENT Key.



6. Select the matrix size for the code using the Up/Down Keys. Press the ENT Key to validate the setting and go back to the window shown in step 5.

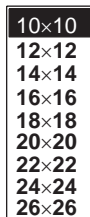

7. Press the ESC Key once to go back to the window shown in step 4.
8. Press the ESC Key once more to return to RUN.

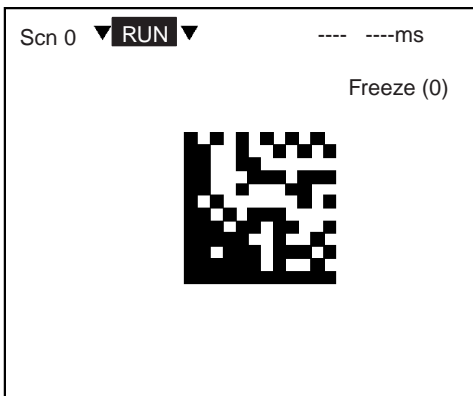

9. Press the Trigger Switch on the Scanner to read the code. If reading is successful, the OK indicator will light and the buzzer will sound. Parameters will be set automatically according to the reading data and the teaching function will be turned OFF auto-

matically. If reading is not successful, the teaching function will remain ON; press the Trigger Switch again.

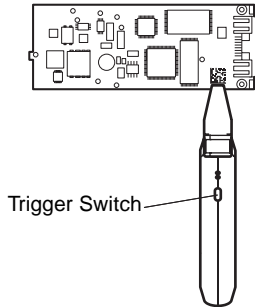

The parameters can be displayed and changed if necessary from **Reading Settings (Manual)**, page 58.

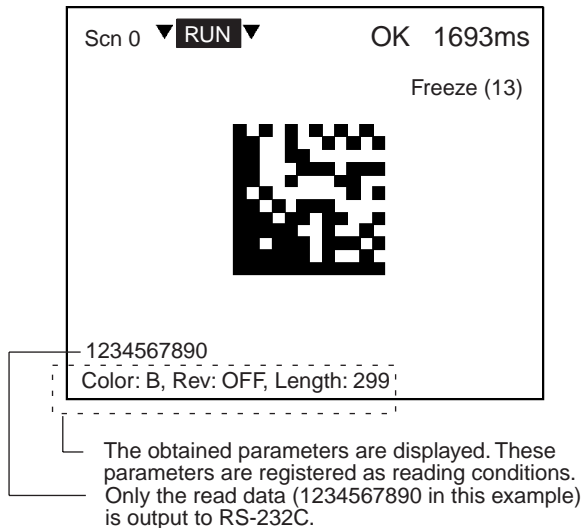

The obtained parameters are displayed. These parameters are registered as reading conditions. Only the read data (1234567890 in this example) is output to RS-232C.

To turn the teaching function OFF, select **Reading Settings (Manual)** from the screen shown in step 5, and press the ENT Key. The teaching function will be turned OFF by entering the **Reading Settings (Manual)** window.

Note If reading is not completed successfully, return to step (5.), select **Reading Settings (Manual)**, and press the ENT Key to cancel the through image. Press the Shift+Up/Down Keys and select a saved image from memory. Measure the length of the finder pattern (L-shape) using **Image Analysis/Measure Length**, return again to **Reading Settings (Manual)**, set the length of the finder pattern, and then perform teaching again. **page 89**

10. This completes the settings.



QR Code Reading

Select the required symbol color. The other reading conditions can be set using the teaching function.

3. Select **QRCode (Normal)** and press the ENT Key. The following screen will be displayed.

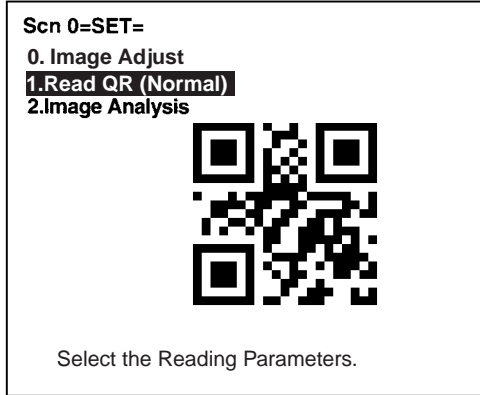

4. Select **Read QR (Normal)** and press the ENT Key.
5. Select **Reading Settings (Teaching)** and press the ENT Key.



6. Select the symbol color using the Up/Down Keys. Press the ENT Key to validate the setting and go back to the window shown in step 5.



Black: Black symbol printed on white base.

White: White symbol printed on black base.



7. Press the ESC Key once to go back to the window shown in step 4.

- 8. Press the ESC Key once more to return to RUN.

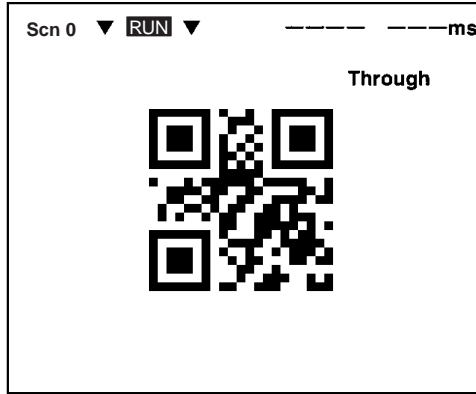

- 9. Press the Trigger Switch on the Scanner to read the code.  
If reading is successful, the OK indicator will light and the buzzer will sound. Parameters will be set automatically according to the reading data and the teaching function will be turned OFF automatically. If reading is not successful, the teaching function will remain ON; press the Trigger Switch again.

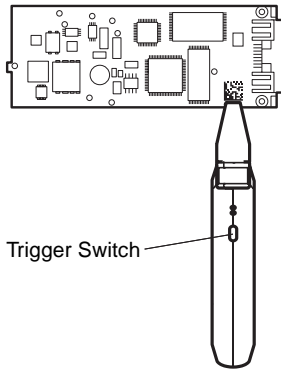

These parameters can be displayed and changed if necessary from **Reading Settings (Manual)**, page 73

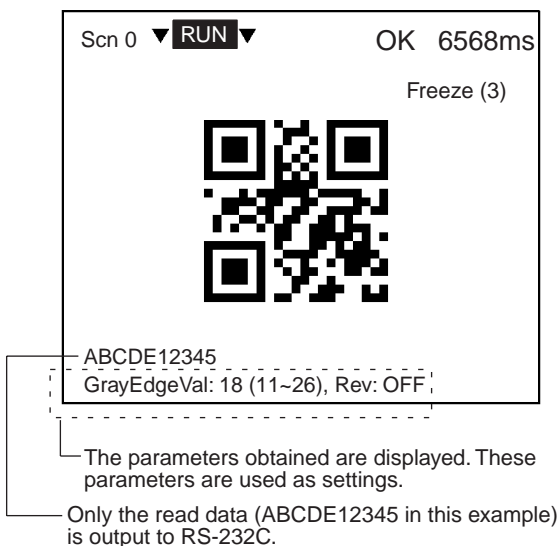

To turn the teaching function OFF, select **Reading Settings (Manual)** from the screen shown in step 5, and press the ENT Key. The teaching function will be turned OFF by entering the **Reading Settings (Manual)** window.

10. This completes the settings.

### 4-3-3 STEP 3: Starting Code Reading

Enter RUN mode to perform readings. The reading judgment is output to external devices through RS-232C.

#### Procedure

- 1,2,3...**
1. Confirm that the RUN indicator (orange) is lit.
  2. Press the Trigger Switch on the Scanner to read the code.

If reading is successful, the OK indicator (green) will light and the buzzer will sound.

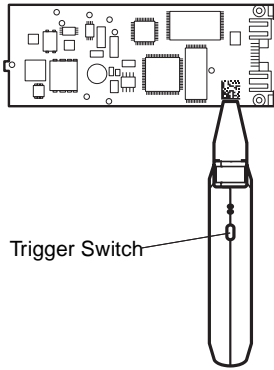

- Note**
1. Hold down the Trigger Switch until the reading is completed.
  2. Repeat the teaching operation if reading cannot be completed successfully.
  3. With the V530-H301 Scanner, hold the Scanner as close to the workpiece as possible.

# SECTION 5

## Operation with the Console

This section describes the procedures required to operate the 2-Dimensional Code Reader from the Console.

5-1	SET (Setting) Mode . . . . .	46
5-1-1	Menu Registration . . . . .	46
5-1-2	Menu Tree . . . . .	49
5-1-3	Image Adjust . . . . .	53
5-2	RUN Mode . . . . .	102
5-3	System Mode . . . . .	107
5-3-1	RS-232C Communications . . . . .	107
5-3-2	Buzzer Setting . . . . .	109
5-3-3	Image Storage . . . . .	110
5-3-4	Version Information . . . . .	112
5-4	Tool Mode . . . . .	113
5-5	Scenes . . . . .	117
5-6	Saving to Flash Memory . . . . .	120

# 5-1 SET (Setting) Mode

## 5-1-1 Menu Registration

The V530-C300E has the four reading modes shown below. Choose the mode that is appropriate for the type of code and the conditions in which it is to be read.

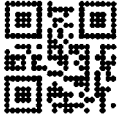
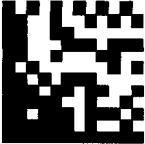
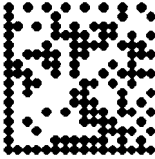
Menu	Contents
QR Code (Normal)	<p>This mode can normally be used for QR Code reading.</p> 
QR Code (Pattern)	<p>Try this mode when reading codes of poor marking quality or codes made up of dots, or any other codes for which stable reading is not possible. Images of finder patterns (the symbols in 3 of the corners) are registered, and the position of codes is determined by searching for these images.</p> <p><b>Note</b> This mode has an orientation tolerance of <math>\pm 10^\circ</math>. Reading is not possible for orientations greater than this.</p> 
Data Matrix (Normal)	<p>This mode can normally be used for Data Matrix reading.</p> 
Data Matrix (Pattern)	<p>Try using this mode when reading codes of poor marking quality or codes made up of dots, or in any other situation where stable reading is not possible. An image of the finder pattern (the L-shape described by 3 of the corners) is registered, and the position of codes is determined by searching for this image.</p> <p><b>Note 1:</b> This menu has an orientation tolerance of <math>\pm 10^\circ</math>. Reading is not possible for orientations greater than this.</p> <p><b>Note 2:</b> Adjust the code size so there are at least 10 pixels per cell and there is a margin of at least 2 pixels around the code.</p> 

Procedure

- 1,2,3... 1. Enter the **SET** mode.

The following items will be displayed.

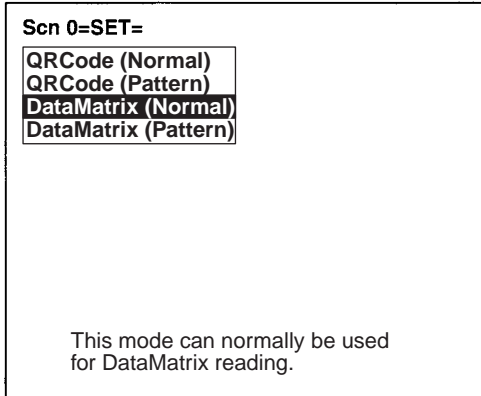

2. Select the required item using the Up/Down Keys and press the ENT Key.

Example: If **QRCode (Normal)** is selected, the following screen will be displayed.

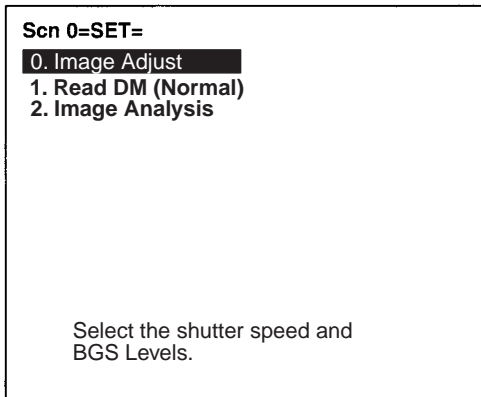

## **Changing Modes**

### **Procedure**

- 1,2,3...** 1. Press the SHIFT and ESC Keys together.  
The modes will be displayed.

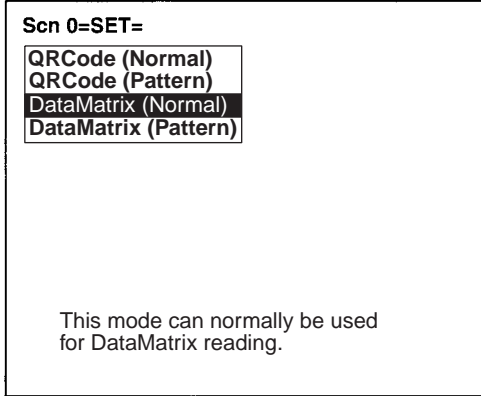

2. Select the required item using the Up/Down Keys and press the ENT Key.



## 5-1-2 Menu Tree

Explanations that apply to more than one mode are covered together. For explanations of the various operations, refer to the pages given in the following menu tree.

### For Data Matrix Code Reading in Normal Mode

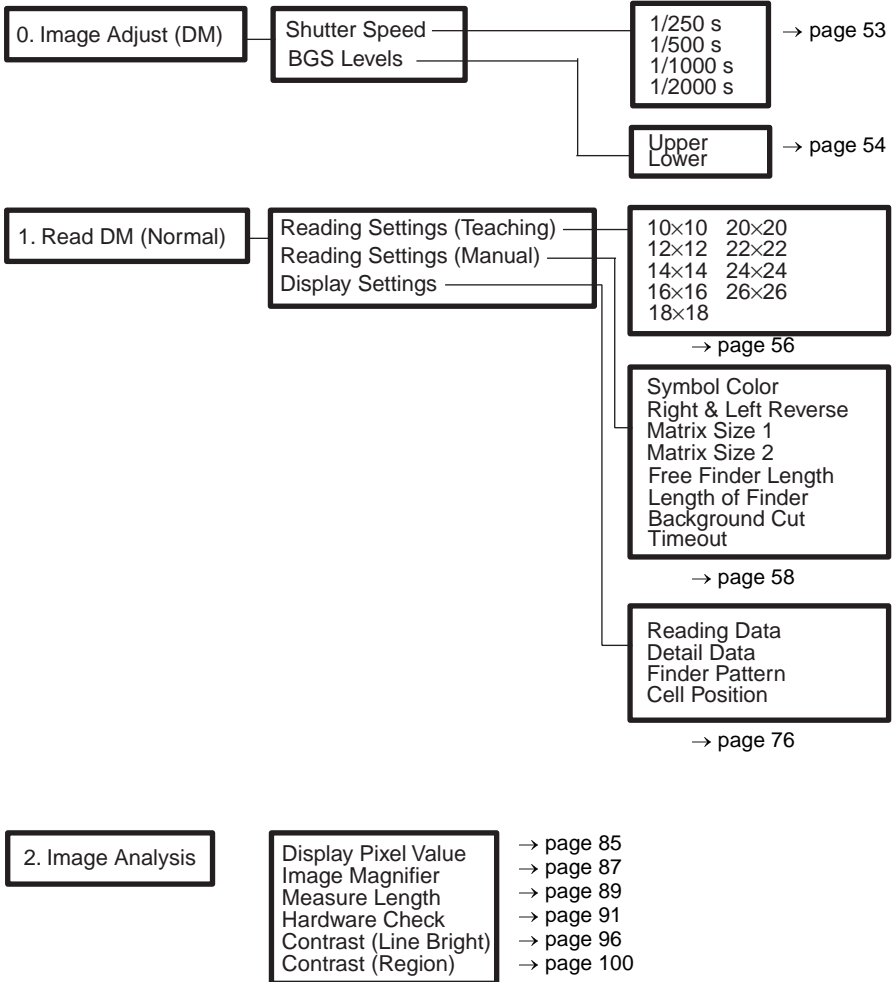

**Note** Refer to page 48 to change the reading mode.

For Data Matrix Code Reading in Pattern Mode

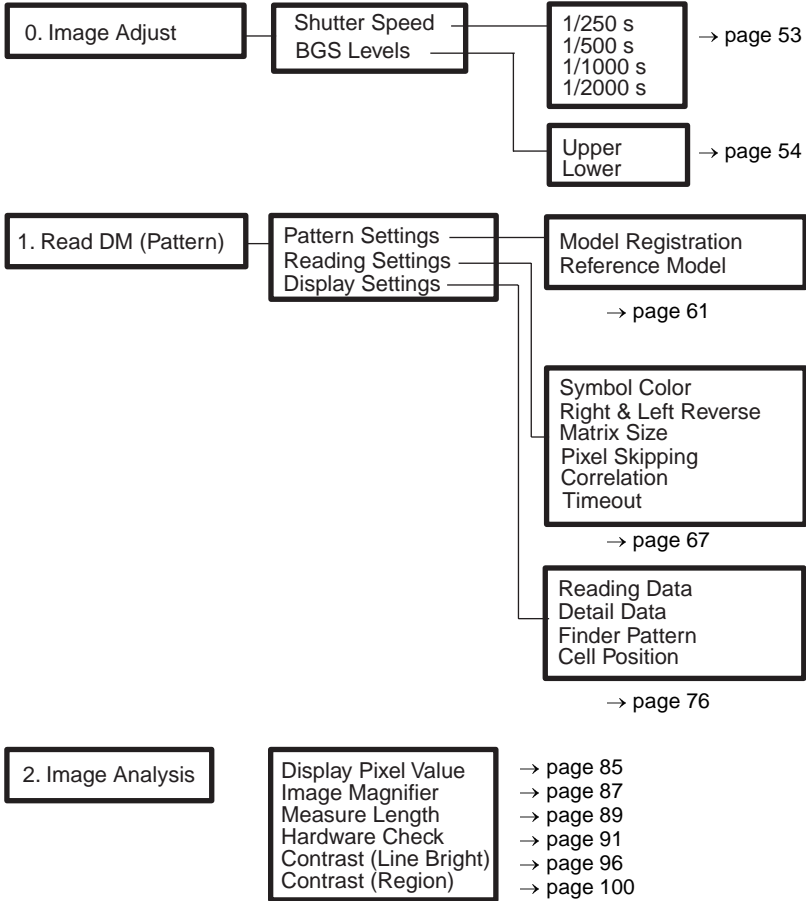

**Note** Refer to page 48 to change the reading mode.

For QR Code Reading in Normal Mode

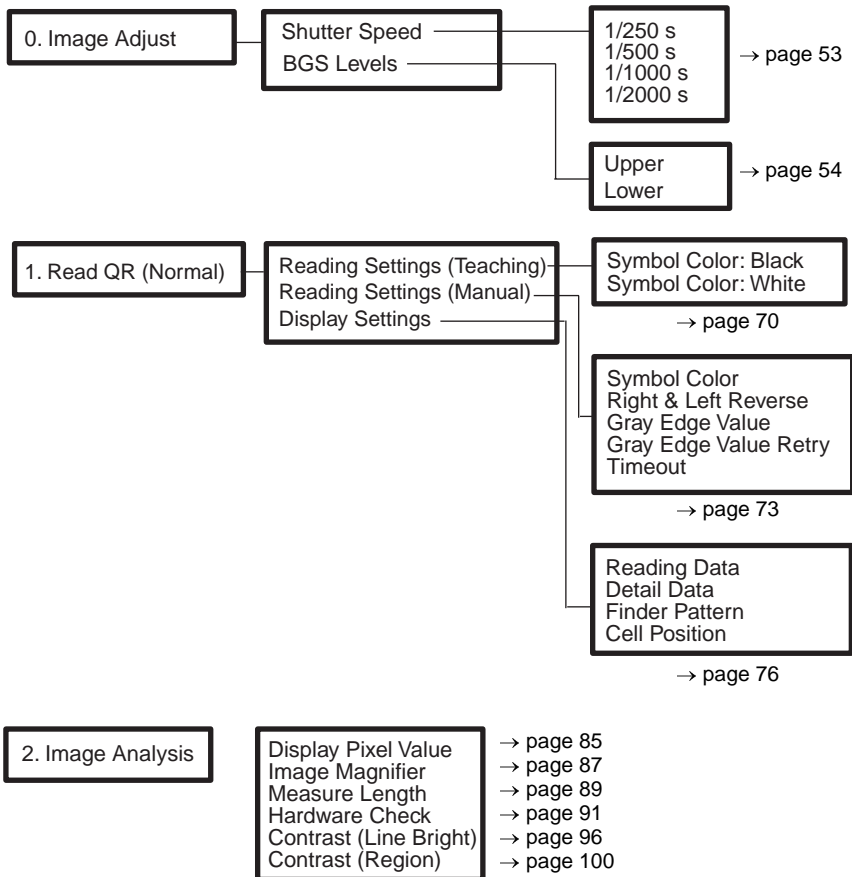

**Note** Refer to page 48 to change the reading mode.

For QR Code Reading in Pattern Mode

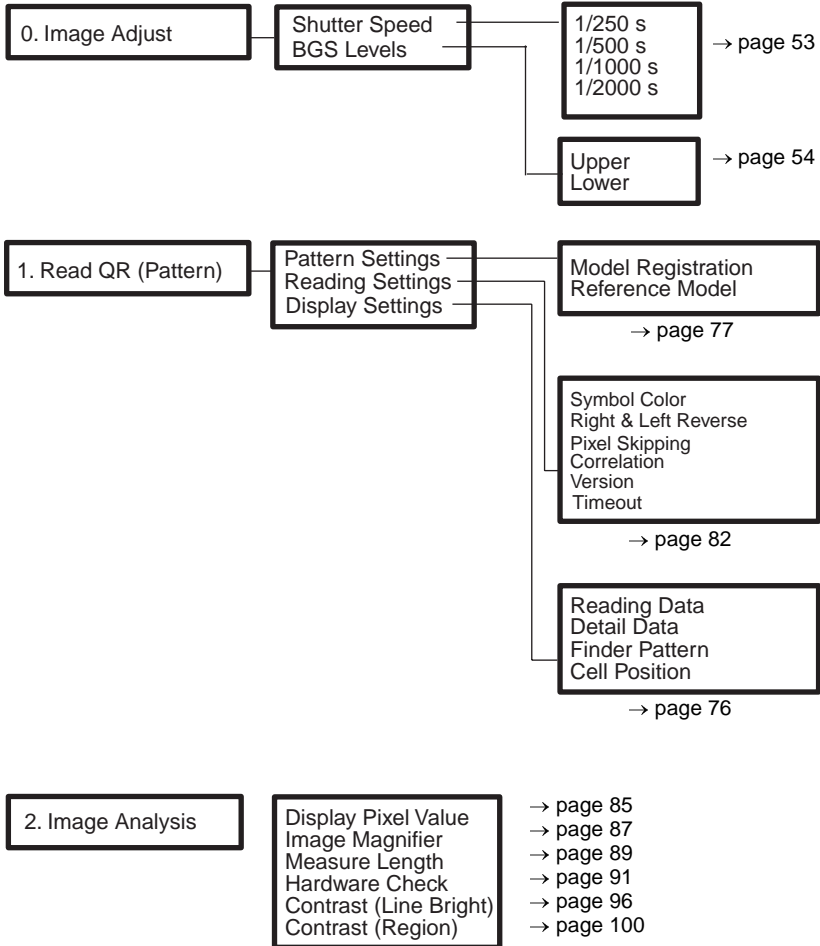

**Note** Refer to page 48 to change the reading mode.

### 5-1-3 Image Adjust

**0. Image Adjust** — Shutter Speed

**0. Image Adjust (DM)** — Shutter Speed

The suitable shutter speed can be selected according to the moving rate of the reading codes.

#### Procedure

- 1,2,3...** 1. Select **0. Image Adjust**.

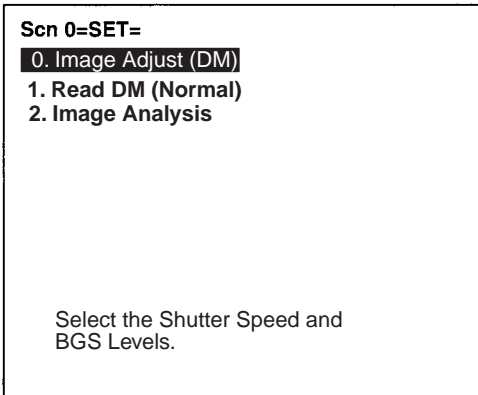

2. Select **Shutter Speed**.



3. Select an appropriate speed whilst viewing the image.  
 Press the ENT Key to validate the setting.

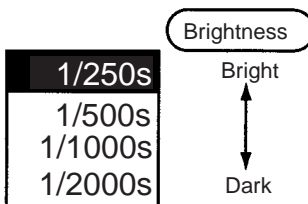

**0. Image Adjust** — **BGS Levels**

**0. Image Adjust (DM)** — **BGS Levels**

Use this setting to set lower and upper limits of the density for images that are read. Densities lower than the set lower limit will be converted to 0 and densities higher than the set upper limit will be converted to 255.

For example, settings can be made so that densities from 150 to 255 will be converted to 0 to 255 and all densities lower than 150 will be converted to 0.

Lower limit: 150 Upper limit: 255

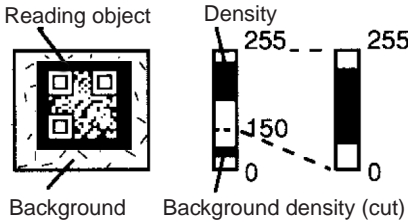

Image areas with densities of 149 or lower will not be read and the density will be changed to 0.

Only image areas with densities between 150 and 255 will be read. The whole image is graded from 0 to 255.

**Procedure**

- 1,2,3...** 1. Select **0. Image Adjust**.

**Scn 0=SET=**  
**0. Image Adjust (DM)**  
 1. Read DM (Normal)  
 2. Image Analysis

Select the Shutter Speed and BGS Levels.

- 2. Select **BGS Levels**.

**Shutter Speed**  
**BGS Levels**

- 3. Change the upper and lower limits as required.

Press the Right Key to increase values by 1. Press the Left Key to decrease values by 1. Press the SHIFT Key together with Right/Left Key to increase/decrease values by 10.

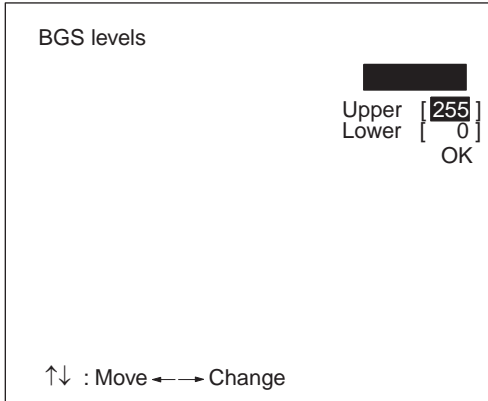

- 4. Select **OK** to validate the settings.

**1. Read DM (Normal)**

**Reading Settings (Teaching)**

Using the teaching function, a reading image is obtained, measurement is performed on this image, and based on the results of this measurement, parameters for reading conditions (symbol color, Right & Left Reverse, Length of Finder) are automatically determined. The results of the settings made using the teaching function can be viewed in *Reading Settings (Manual)*.

**Teaching Procedure**

**1,2,3...**

1. Select **Read DM (Normal)**.

A through image will be displayed automatically.

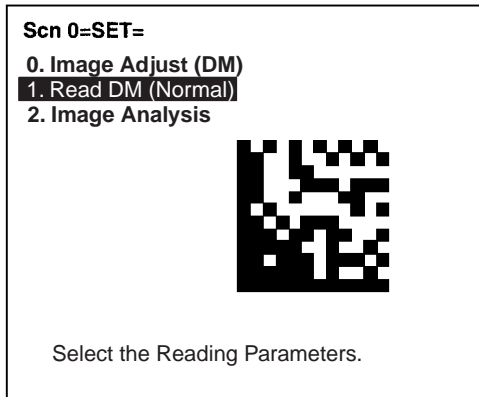

2. Select **Reading Settings (Teaching)**.



3. Select the code size.

Use the Up/Down Keys to select the required setting, and validate this setting by pressing the ENT Key. The display will return to the window shown in step 2.

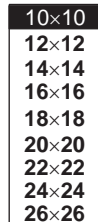



- 4. Press the ESC Key once to return to window shown in step 1.
- 5. Press the ESC Key once more to go into RUN mode.

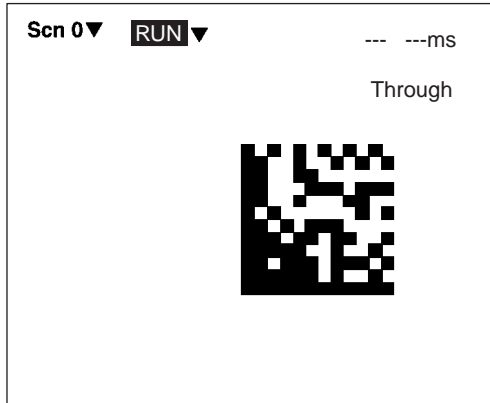

- 6. Press the Trigger Switch on the Scanner to perform reading.  
If reading is successful, the OK indicator will light and the buzzer will sound. Parameters will be automatically set based on the reading data. If the reading is performed successfully, the teaching function will automatically turn OFF. To redo the settings, go to SET mode and repeat the procedure from step 1.

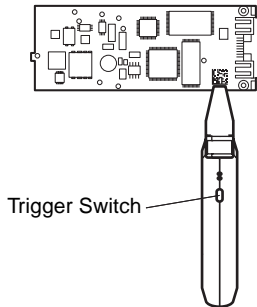

It is possible to view and, if necessary, change the parameter setting in **Reading Settings (Manual)**, page 58

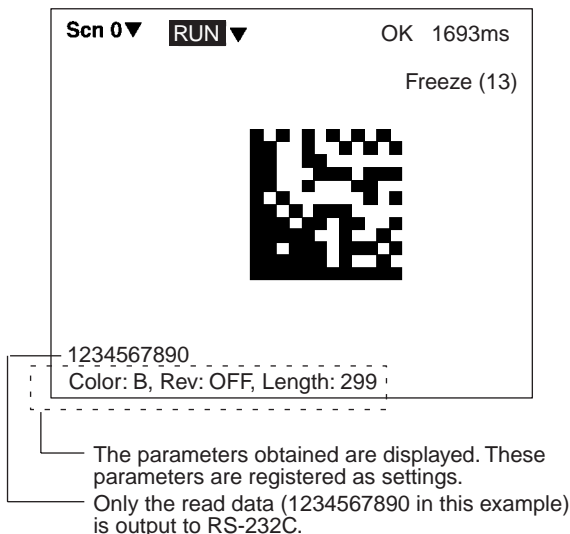

If reading is not performed correctly, the teaching function will stay ON. To turn the teaching function OFF, select **Reading Settings (Manual)** from the screen shown in step 2, and press the ENT Key. The teaching function will be turned OFF by entering the **Reading Settings (Manual)** window.

**Note** If the teaching operation is not successful, measure the length of finder pattern using **Image Analysis/Measure Length** and set this value for length of the finder pattern in **Reading Settings (Manual)**, and then repeat the teaching operation.

### 1. Read DM (Normal)

### Reading Settings (Manual)

Set the various reading condition parameters. This menu can also be used to view or change parameters set using the teaching function.



**Note** “Length of Finder” is the length of the finder patterns for the code expressed in pixel units. The V530-C300E detects finder patterns that correspond to this length and performs readings. “Free Finder Length” is a function that is used when there are several different sizes of reading codes, with large differences in the length of the finder. If this function is turned ON, any finder pat-

terns at least as long as the value set as the “Length of Finder” will be detected and reading performed.

*A	Symbol Color	:	Black	▼
*B	Right &Left Reverse	:	OFF	▼
C	Matrix Size 1	:	10×10	▼
	Matrix Size 2	:	None	▼
D	Free Finder Length	:	OFF	▼
E	Length of Finder	:	[150]	
*F	Background Cut	:	Middle	▼
G	Timeout	:	[1000]ms	

\*: Indicates items set automatically using the teaching function.

**1,2,3...** 1. Select the color of symbol.

Black (Default setting)	Black symbol printed on white base. 
White	White symbol printed on black base. 
Auto	Automatically determines the appropriate symbol color. Use this setting when reading codes that include both symbol colors. If, however, the symbol color is known to be one or the other (i.e., either black or white), set to black or white to reduce the required processing time.

2. Select whether Right & Left Reverse of Data Matrix is necessary.

ON	Necessary For reading an image after reflection, or through the back of a transparent material, such as glass.
OFF (Default setting)	For normal reading (from the front of the object)
Auto	Automatically determines whether Right & Left Reverse is required. Use this setting when reading codes that include both types. If, however, the necessity of Right & Left Reverse is known one way or the other, set to ON or OFF to reduce the required processing time.

3. Select the code size. It is possible to set up to two (1 or 2) code sizes. If the reading codes are all the same size, set this size as code size 1, and set code size 2 to "None."  
(10 × 10 to 26 × 26; Default setting: Code size 1 = 10 × 10, code size 2 = None)
4. Turn ON the free finder length setting if there is more than one size of code being read and the difference is large enough to interfere with reading. If the free finder length setting is turned ON, an code of the same size or larger than the finder length set in (5) will be read. (Default setting: OFF)
5. Input the length of the finder pattern (L-shape) in pixel units.  
(50 to 480; Default setting: 150)  
This setting can be made automatically using the teaching function, so whenever resetting the reading conditions, always use the teaching function first. **page 56**  
When Free Finder Length (4) is set to ON, set the minimum length of the reading codes as the value of the length of the finder pattern.
6. Select the background cut level required when searching for finder patterns (L-shapes). when reading for white symbol printed on black base, such as with direct marking, it is recommended that this level is set to middle or strong. (Weak/Middle/Strong; Default setting: Weak)
7. Select the timeout time for decoding one reading. (Setting range: 200 to 2,000 ms; default setting: 1,000 ms)

**Normal Procedure**

- 1,2,3...** 1. Select **Read DM (Normal)**.

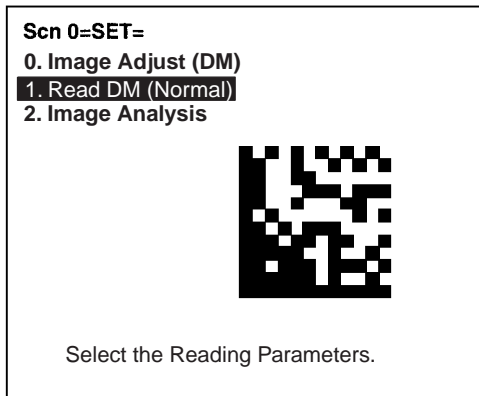

2. Select **Reading Settings (Manual)**.



3. Set the items as required.

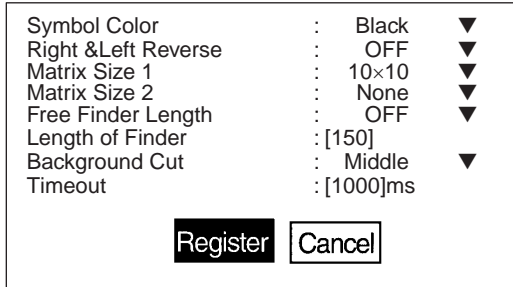

4. Select **Register** to validate the settings and leave this window.

**1. Read DM (Pattern)**

**Pattern Settings**

The method of registering model images of finder patterns, and using these models to find finder patterns from input images is called “pattern search.” Because image patterns are used, code positions can still be found with greater accuracy than with Normal mode, even if the printing quality is poor.

**Note** There is an orientation tolerance of  $\pm 10^\circ$  with this method. Models cannot be detected for deviations greater than this.

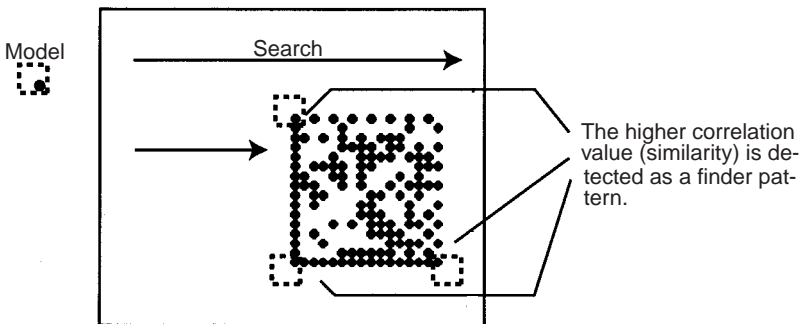

**Note** When using this menu, set the code size to satisfy the following conditions.

- There are more than 10 pixels per cell.
- There is a margin of at least 2 cells around the code.

## Model Registration

Use the following procedure to register models of finder patterns.

### Procedure

- 1,2,3...** 1. Select **Read DM (Pattern)**.

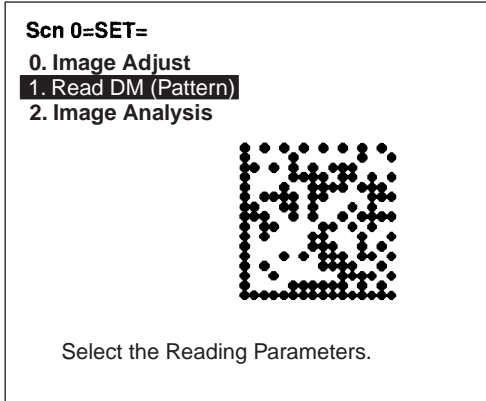

2. Select **Pattern Settings**.



3. Select **Model Registration**.



- Align the Scanner on the code to be read and press the Trigger Switch on the Scanner.

Images taken at 4 shutter speeds will be saved in memories 0 to 3.

Memory	Shutter speed
Memory 0	1/250
Memory 1	1/500
Memory 2	1/1000
Memory 3	1/2000

**Scn 0=SET=** 1. Read DM (Pattern) Model Registration

Through

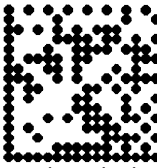

Input trigger and get the image for model registration.  
(If you register model from the stored image, input ENT Key.)

- Select one of the images from memories 0 to 3 using the Shift+Up/Down Keys and press the ENT Key.

**Scn 0=SET=** 1. Read DM (Pattern) Model Registration

Mem 0  
1/250

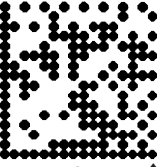

Select image with SHIFT+↑↓ Key and input ENT key. ESC key is back to previous display.

6. Press the ENT Key and select the matrix size.

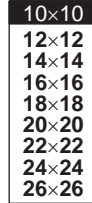

7. Select the code orientation.



The orientation is expressed as the rotation of the code along the axis of the Scanner.

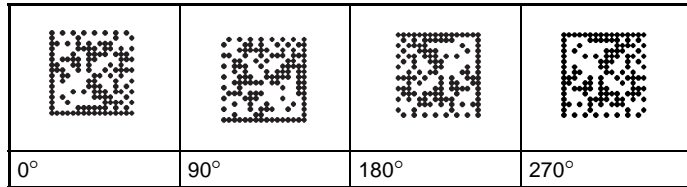

Reading is possible within ±15° of these angles.

8. Draw an L-shape on the code.

Set the three points of the L-shape moving the cursor with the Up, Down, Left, and Right Keys and pressing the ENT Key at each point.

**Scn 0=SET= 1. Read DM (Pattern)  
Model Registration**

Mem 0  
1/250

Select upper left point of Finder Pattern.  
(205, 191) (204, 291) (304, 291)



- 9. Press the ENT Key to complete registration.  
To correct the registration, press the ESC Key and return to step (4).

**Note** Go to **Reference Model**, and check that models, including background, are registered in 3 places.

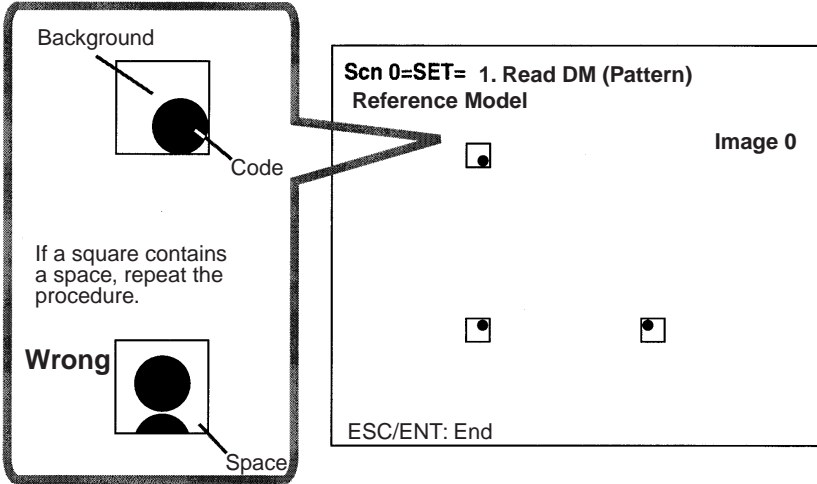

**Reference Model**

It is possible to view the model image (without the surrounding code) by displaying it on the monitor screen. After registering a model, be sure to use this function to check that all 3 places of the model including background, have been registered correctly.

**Procedure**

- 1,2,3... 1. Select **Read DM (Pattern)**.

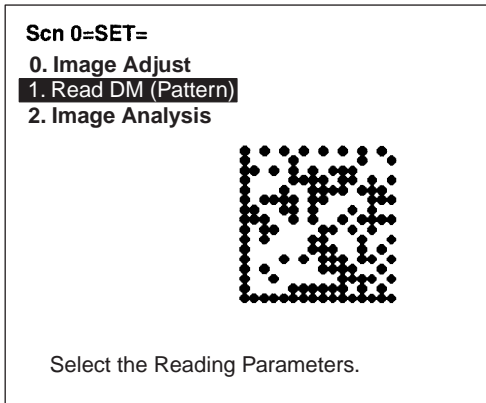

2. Select **Pattern Settings**.



3. Select **Reference Model**. The model image will be displayed.



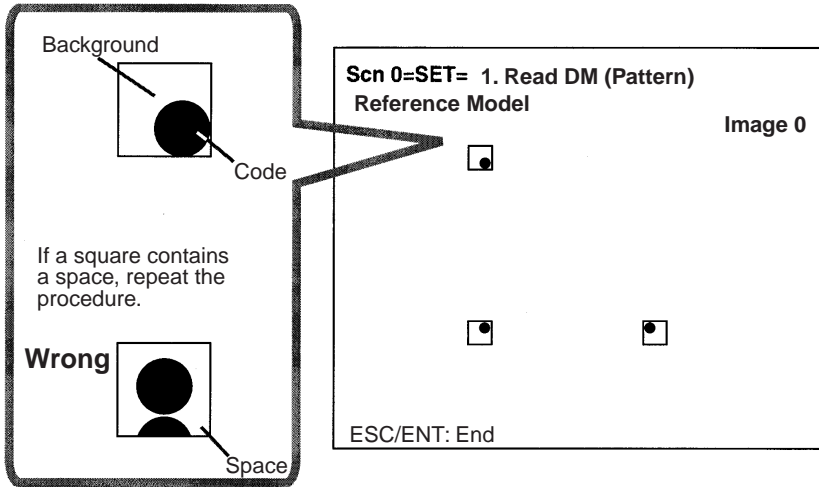

4. Press the ENT or ESC Key to leave this screen.



**1. Read DM (Pattern)**

**Reading Settings**

Set the reading conditions and the conditions for searching for a model when reading Data Matrix codes.

A	Symbol Color	:	Black	▼
B	Right &Left Reverse	:	OFF	▼
C	Matrix Size	:	10×10	▼
D	Pixel Skipping	:	[ 5]	
E	Correlation	:	[ 50]	
F	Timeout	:	[500]ms	

**1,2,3...** 1. Select the color of symbol.

Black (Default setting)	Black symbol printed on white base.	
White	White symbol printed on black base.	

- Select whether Right & Left Reverse of Data Matrix codes is necessary.

ON	For reading an image after reflection, or through the back of a transparent material, such as glass.
OFF (Default setting)	For normal reading (from the front of the object)

- Select the code size.  
(10 × 10 to 26 × 26; Default setting: 10 × 10)
- Change the pixel skipping parameters used to search for a model.  
(1 to 20, default setting: 5)

The processing time can be reduced if the pixel skipping parameters are set to larger values. However, depending on the image, the search may not be performed since the accuracy is reduced. After changing the setting, perform a search to confirm whether the search can be performed correctly.

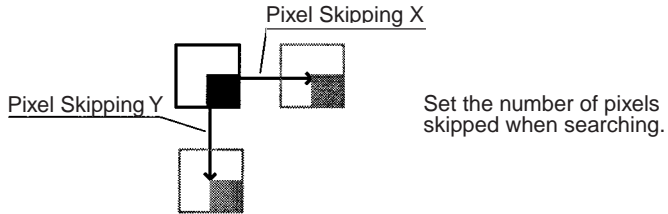

- Set the correlation threshold value for detecting finder patterns. Locations with correlation values higher than the threshold are detected. (1 to 100; Default setting: 50)
- Set the timeout time for decode processing for reading one image. (20 to 2,000 ms; Default setting: 500 ms)

**Note** If *Display Settings/Finder Pattern* is set to ON, whether finder patterns can be detected or not can be confirmed on the screen. If detection is not possible, decrease the correlation threshold value and the pixel skipping parameter and check the model image. If, on the other hand, too many places are detected, increase the correlation value and pixel skipping parameter.

Procedure

- 1,2,3... 1. Select **DM (Pattern)**.

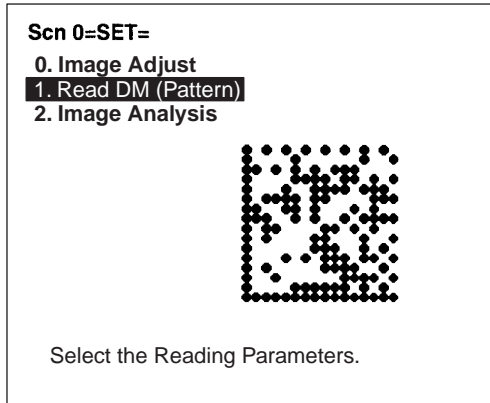

2. Select **Reading Settings**.

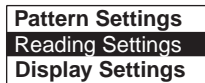

3. Set the items as required.

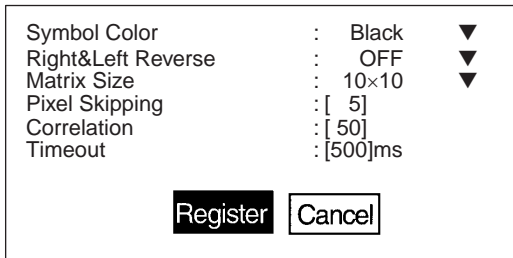

4. Select **Register** to validate the settings and leave this window.

**1. Read QR (Normal)****Reading Settings (Teaching)**

Using the teaching function, a reading image is obtained, measurement is performed on this image, and based on the results of this measurement, parameters for reading conditions (Right & Left Reverse, Gray Edge Value, Shutter Speed) are automatically determined. The results of the settings made using the teaching function can be viewed in **Reading Settings (Manual)**.

**Teaching Procedure**

- 1,2,3...** 1. Select **Read QR (Normal)**.

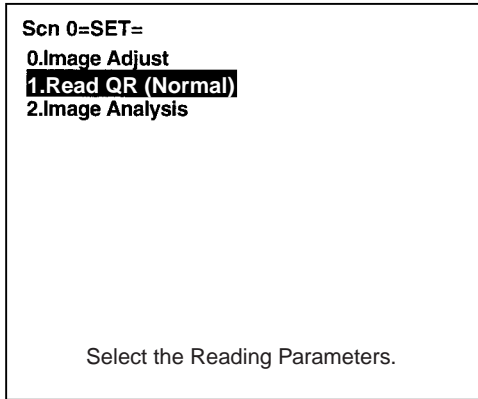



2. Select **Reading Settings (Teaching)**.



- 3. Select the required symbol color.

Use the Up/Down Keys to select the required setting, and validate this setting by pressing the ENT Key. The display will return to the window shown in step 2.

Symbol Color: Black  
Symbol Color: White

Black	Black symbol printed on white base. 
White	White symbol printed on black base. 

- 4. Press the ESC Key to return to the window shown in step 1.
- 5. Press the ESC Key once more to return to RUN (Run) mode.

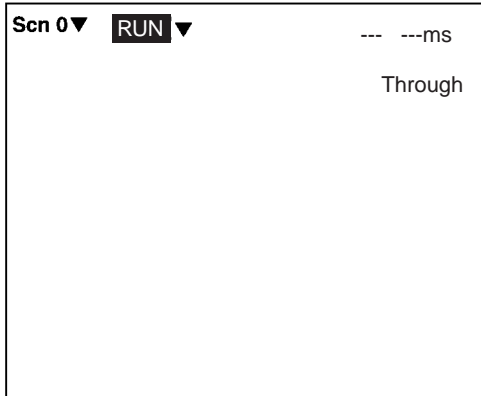

6. Press the Trigger Switch on the Scanner to perform reading.

If reading is successful, the OK indicator will light and the buzzer will sound. Parameters will be automatically set based on the reading data. If the reading is performed successfully, the teaching function will automatically turn OFF. To redo the settings, go to SET mode and repeat the procedure from step 1.

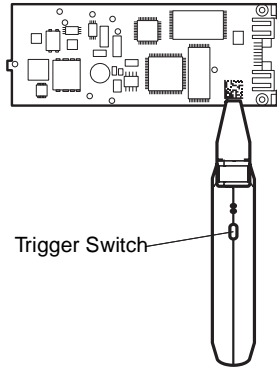



It is possible to view and, if necessary, change the parameter setting in **Reading Settings (Manual)**.

page 73



The parameters obtained are displayed. These parameters are used as settings. Only the read data (ABCDE12345 in this example) is output to RS-232C.

If reading is not performed correctly, the teaching function will stay ON. To turn the teaching function OFF, select **Reading Settings (Manual)** from the screen shown in step 2, and press the ENT Key. The teaching function will be turned OFF by entering the **Reading Settings (Manual)** window.

**1. Read QR (Normal)**

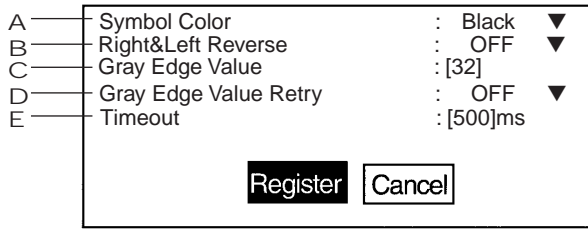

**Reading Settings (Manual)**

The reading conditions can be set manually. If parameters have been set using the teaching function, those parameters can be viewed or changed, if necessary, from this menu.



**Note** Items 2 and 3 above can be set using the teaching function.

- 1,2,3... 1. Select the color of symbol.

Black (Default setting)	Black symbol printed on white base. 
White	White symbol printed on black base. 

**Note** By default, the DIP switch settings will take priority.

2. Select whether Right & Left Reverse of QR Codes is necessary.

ON	For reading an image after reflection, or through the back of a transparent material, such as glass.
OFF (Default setting)	For normal reading (from the front of the object)
AUTO	The right/left reversal of the code will be determined automatically. Use this setting if the codes are not oriented consistently. Processing will be faster if ON or OFF is used.

3. Select the gray edge value (i.e., the ratio of black and white) used to detect finder patterns. (Setting range: 1 to 127; default setting: 32)  
 If the ratio of the intensity of black and white is large, set to a large value, and if the ratio of the intensity of black and white is small, set it to a small value.  
 This setting can be made using the teaching function (which automatically measures the optimum value), so whenever resetting the reading conditions, always use this function first. **page 70**
4. Select whether Gray Edge Value Retry is necessary. If it is turned ON, and reading is not correctly performed, then the reading will be attempted again with a higher or lower gray edge value. (Default setting: OFF)
5. Select the timeout time for decoding one reading. (Setting range: 200 to 2,000 ms; default setting: 500 ms)

Normal Procedure

- 1,2,3... 1. Select **Read QR (Normal)**.

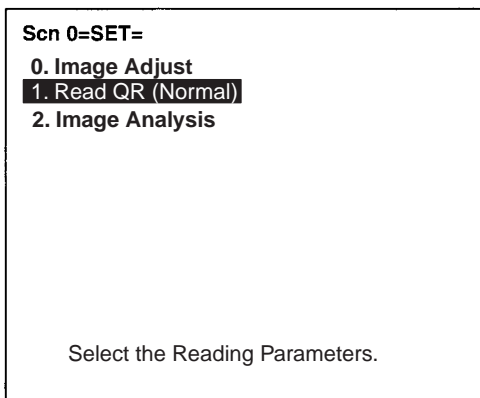

2. Select **Reading Settings (Manual)**.

The parameters will be displayed.



3. Edit the parameters as required.

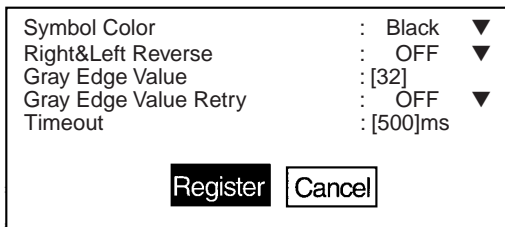

4. Select **Register**.

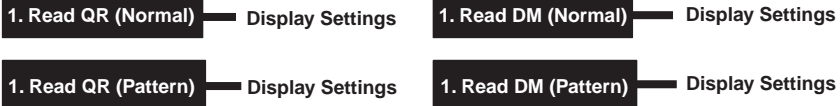

Set the contents displayed in RUN mode. The processing time will increase in proportion to the number of display items selected.

A	Reading Data	:	ON	▼
B	Detail Data	:	ON	▼
C	Finder Pattern	:	ON	▼
D	Cell Position	:	ON	▼
<input type="button" value="Register"/> <input type="button" value="Cancel"/>				

- 1,2,3...**
1. Select whether or not to display reading data on the screen. (The default setting is ON.)
  2. Select whether or not to display detailed data on the screen. (The default setting is ON.)  
If turned ON, information such as detailed information about codes and pixels per cell, etc. is displayed.
  3. Select whether or not to display finder pattern positions on the screen. (The default setting is ON.)
  4. Select whether or not to display cell recognition positions on the screen. (The default setting is ON.)

**Procedure**

- 1,2,3...**
1. Select **Read\*\***.

**Scn 0=SET=**

**0. Image Adjust (DM)**

**1. Read DM (Normal)**

**2. Image Analysis**

Select the Reading Parameters.

2. Select **Display Settings**.



3. Set the items as required.

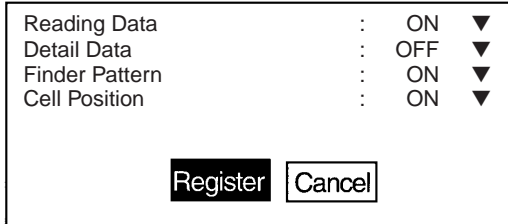

4. Select **Register** to validate the settings and leave this window.

**1. Read QR (Pattern) — Pattern Settings**

The method of registering model images of finder patterns, and using these models to find finder patterns from input images is called “pattern search.” Because image patterns are used, code positions can still be found with greater accuracy than with Normal mode, even if the printing quality is poor.

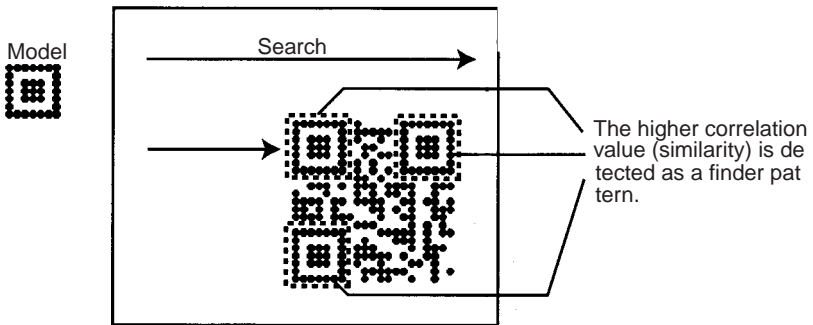

**Model Registration**

Use the following procedure to register models of finder patterns.

**Procedure**

- 1,2,3... 1. Select **Read QR (Pattern)**.  
A through image will automatically be displayed on the screen.

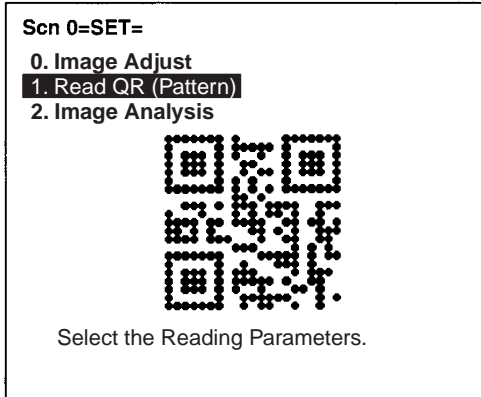

- 2. Select **Pattern Settings**.



- 3. Select **Model Registration**.



- Align the Scanner on the code to be read and press the Trigger Switch on the Scanner.

Images taken at 4 shutter speeds will be saved in memories 0 to 3.

Memory	Shutter speed
Memory 0	1/250
Memory 1	1/500
Memory 2	1/1000
Memory 3	1/2000

**Scn 0=SET=** 1. Read QR (Pattern)  
Model Registration

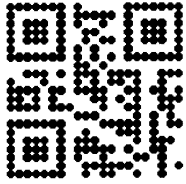

Through

Input trigger and get the image for model registration.  
(If you register model from the stored image, input ENT Key.)

- Select one of the images from memories 0 to 3 using the Shift+Up/Down Keys and press the ENT Key.

**Scn 0=SET=** 1. Read QR (Pattern)  
Model Registration

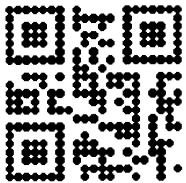

Mem 0  
1/250

Select image with SHIFT+↑↓ Key and input ENT key. ESC key is back to previous display.

- 6. Select the QR Code version.

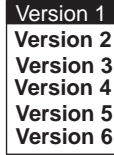

- 7. Draw a square over the region to be registered as a model.

Specify the upper left, lower left and lower right corners of the square. Move the cursor with the Cursor Keys and press the ENT Key for each point.

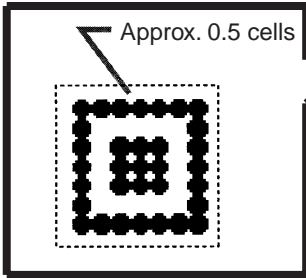

Scn 0=SET= 1. Read QR (Pattern)  
Model Registration

Mem 0  
1/250

Select upper left point of  
Finder Pattern.  
(90, 130) (90, 230) (190, 230)

**Note** Register a find pattern with a margin of approx. 0.5 cells.



8. Press the ENT Key to complete registration.

To correct the registration, press the ESC Key and return to step (4).

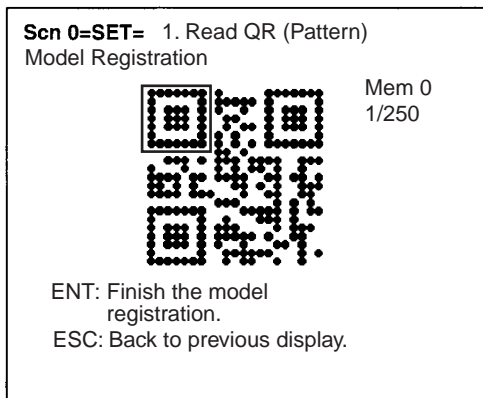

## Reference Model

It is possible to view the model image (without the surrounding code) by displaying it on the monitor screen. After registering a model, be sure to use this function to check that the finder patterns for the model have been registered.

## Procedure

- 1,2,3...** 1. Select **Read QR (Pattern)**.

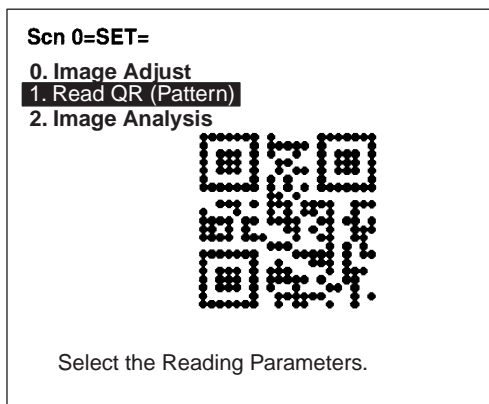

- 2. Select **Pattern Settings**.



- 3. Select **Reference Model**.



The model image will be displayed.

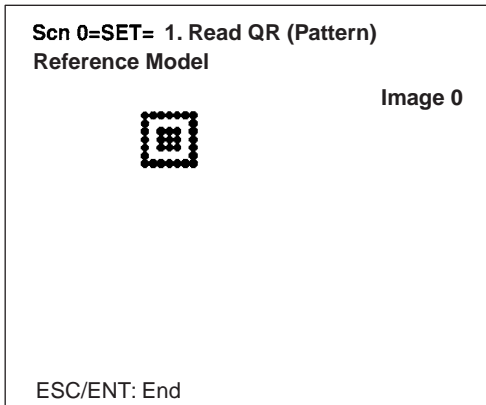



- 4. Press the ENT or ESC Key to leave this screen.

**1. Read QR (Pattern)** — Reading Settings

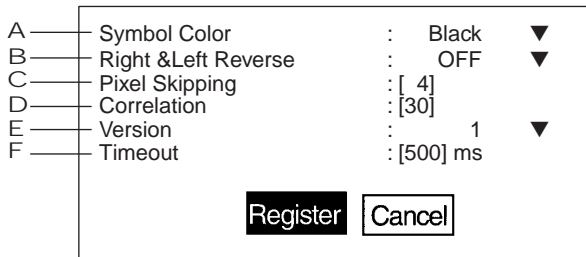
Set the reading conditions and the conditions for searching for a model for QR Code reading.



- 1,2,3... 1. Select the color of symbol.

Black (Default setting)	Black symbol printed on white base. 
White	White symbol printed on black base. 

2. Select whether Right & Left Reverse of QR Codes is necessary.

ON	For reading an image after reflection, or through the back of a transparent material, such as glass.
OFF (Default setting)	For normal reading (from the front of the object)

3. Change the pixel skipping parameters used to search for a model.  
(Setting range: 1 to 20; default setting: 4)  
The processing time can be reduced if the pixel skipping parameters are set to larger values. However, depending on the image, the search may not be performed since the accuracy is reduced. After changing the setting, perform a search to confirm whether the search can be performed correctly.

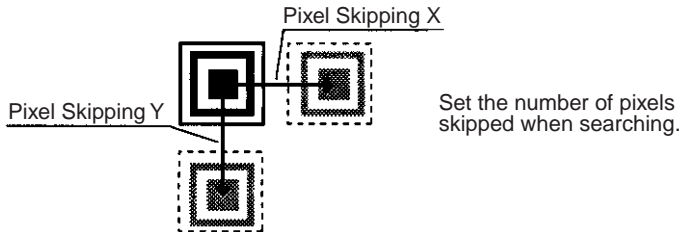

4. Set the correlation threshold value for detecting finder patterns. Locations with correlation values higher than the threshold are detected. (Setting range: 1 to 100; default setting: 30)
5. Set the version information for the QR Code to be read. (1 to 6)  
The version specified when the model was registered will be displayed. (Default setting: Version 1)

**Note** If the wrong version information is set, the reading can not be performed correctly.

6. Select the timeout time for decoding one reading. (Setting range: 200 to 2,000 ms; default setting: 500 ms)

If **Display Settings/Finder Pattern** is set to ON, whether finder patterns can be detected or not can be confirmed on the screen.  
 If detection is not possible, decrease the correlation threshold value and the pixel skipping parameter and check the model image. If, on the other hand, too many places are detected, increase the correlation value and pixel skipping parameter.

**Procedure**

- 1,2,3...** 1. Select **Read QR (Pattern)**.

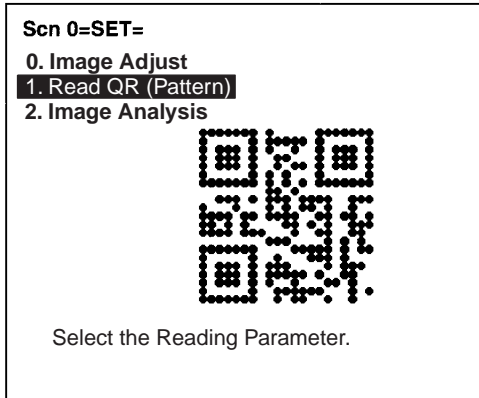

2. Select **Reading Settings**.



3. Set the items as required.

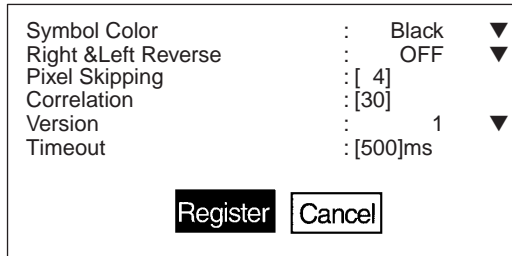

4. Select **Register** to validate the settings and leave this window.

2. Image Analysis

Display Pixel Value

Displays the density information in the range 0 to 255 for a specific area.

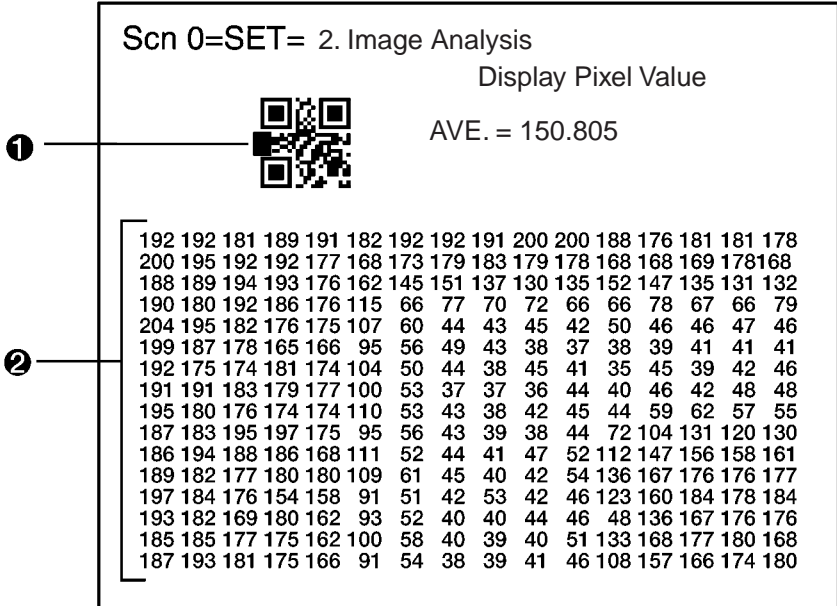

- 1,2,3... 1. Specified area is 16 x 16 pixels.  
 Use Up/Down/Left/Right Keys to move to the position for which density information is required.  
 Press the SHIFT Key at the same time to move faster.
2. The density information for the specified area is displayed.

**Note** Analysis is not possible for through images.

## Procedure

- 1,2,3...** 1. Select **2. Image Analysis**.

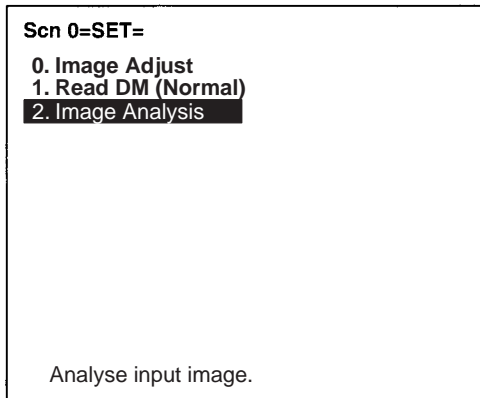

2. Select **Display Pixel Value**.

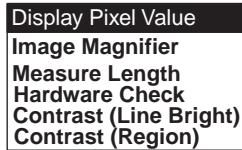

3. Move to the required area by using the Up/Down/Left/Right Keys.  
The density information will be displayed.  
Press the SHIFT Key at the same time to move faster.
4. Press the ESC Key to leave this screen.

## 2. Image Adjust

## Image Magnifier

Magnifies the image in a specified area.

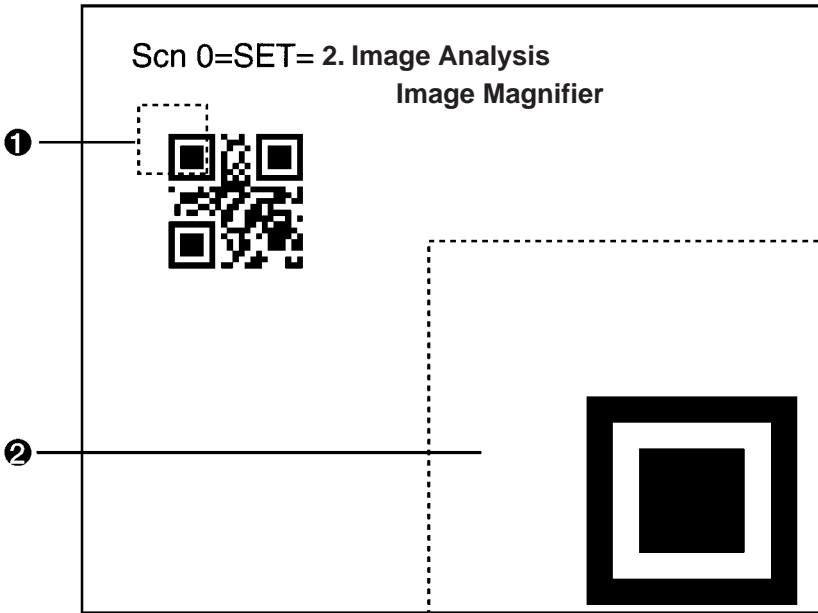

- 1,2,3...**
1. The specified area is 32 x 32 pixels (fixed).  
Use the Up/Down/Left/Right Keys to move to the position to be magnified.  
Press the SHIFT Key at the same time to move faster.
  2. The image in the specified area is magnified.

**Note** Analysis is not possible for through images.

## Procedure

- 1,2,3...** 1. Select **2. Image Analysis**.

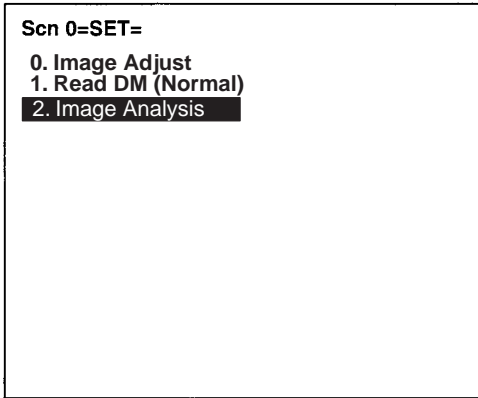

2. Select **Image Magnifier**.

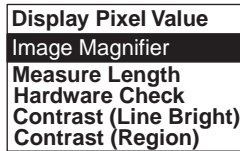

3. Move to the specified area using Up/Down/Left/Right Keys.  
Press the SHIFT Key at the same time to move faster.
4. Press the ENT Key.  
A magnified image is displayed within a dotted frame.
5. Press the ESC Key to leave this screen.



2. Image Analysis

Measure Length

Measures the size of cells in pixels.

For stable reading, adjust the field of vision to be at least five pixels per cell.

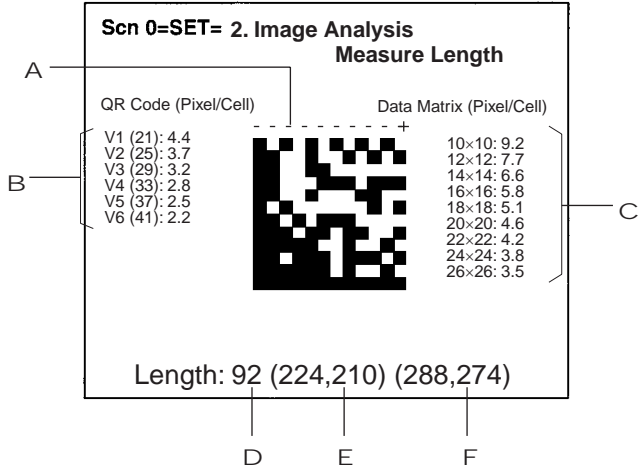

1,2,3...

1. Specify the beginning and end point of the line to be measured.
2. The number of pixels per cell is displayed for QR Codes.
3. The number of pixels per cell is displayed for Data Matrix codes. In the above example, the number of pixels per cell for a 12 × 12 Data Matrix code is 7.7.
4. The length of the dotted line in pixels is displayed.
5. The coordinates of the beginning point are displayed.
6. The coordinates of the end point are displayed.

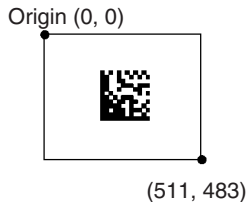

## Procedure

- 1,2,3...** 1. Select **2. Image Analysis**.

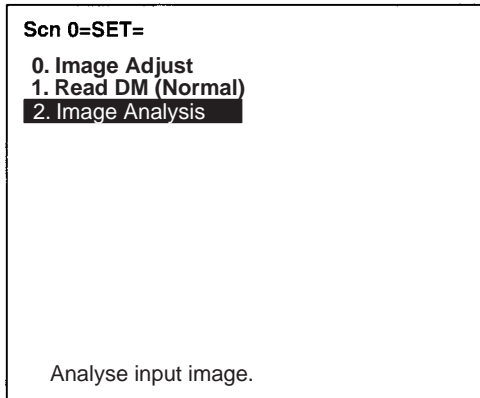

2. Select **Measure Length**.

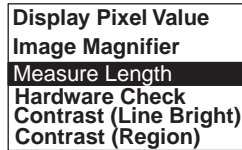

3. Move the cross cursor to the beginning point using Up/Down/Left/Right Keys and press the ENT Key.  
Press the SHIFT Key at the same time to move faster.
4. Specify the end point in the same way.  
The length of the straight line is measured.
5. Press the ESC Key to leave this screen.

**2. Image Analysis**

**Hardware Check**

Performs the following 5 hardware checks on the Controller and Scanner.

No.	Item
1	RUN indicator
2	OK indicator
3	Trigger input
4	External trigger input
5	SW1 to SW6 on DIP switch

- 1,2,3...** 1. Select **2. Image Analysis.**

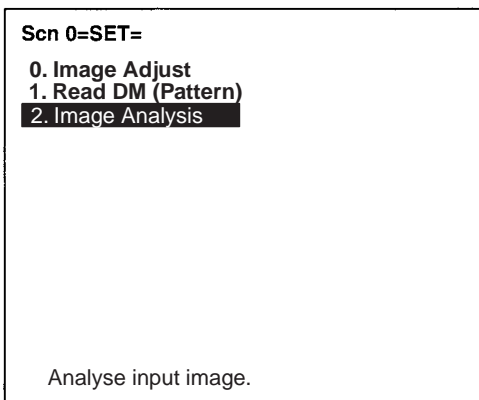

2. Select **Hardware Check.**

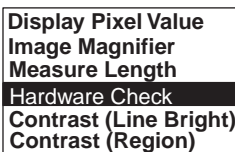

3. Select the item to be checked with the Up/Down Keys.



■ **Selecting RUN LED**

- 4. If the RUN indicators on the Scanner and Controller light at 1-s intervals, the hardware is normal. Press the ESC Key to return to step (3).

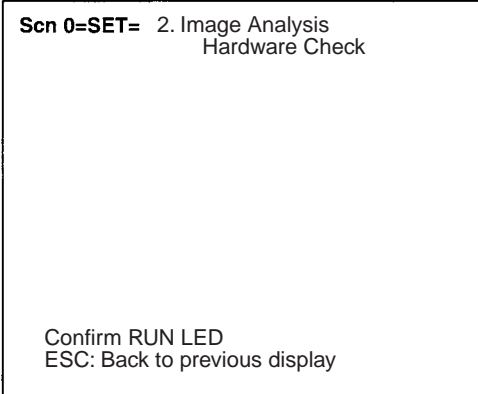

■ **Selecting OK LED**

- 4. If the OK indicator on the Scanner lights at 1-s intervals and the buzzer sounds at 1-s intervals, the hardware is normal. Press the ESC Key to return to step (3).

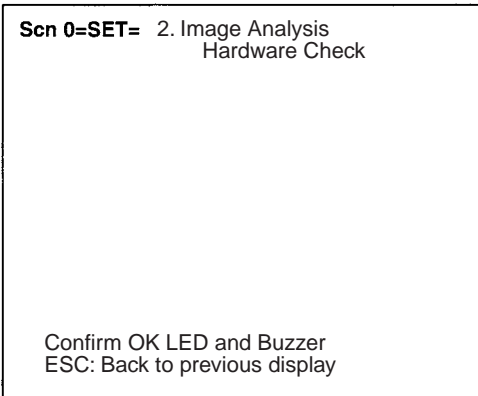

■ **Selecting Input Trigger**

- 4. Press the Trigger Switch on the Scanner.

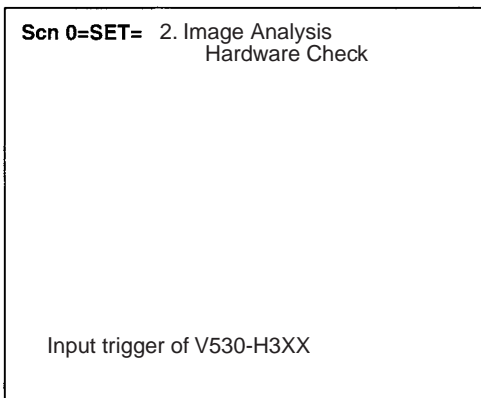

- 5. If "OK ESC: Back to previous display" is displayed on the screen, the hardware is normal. Press the ESC Key to return to step (3).

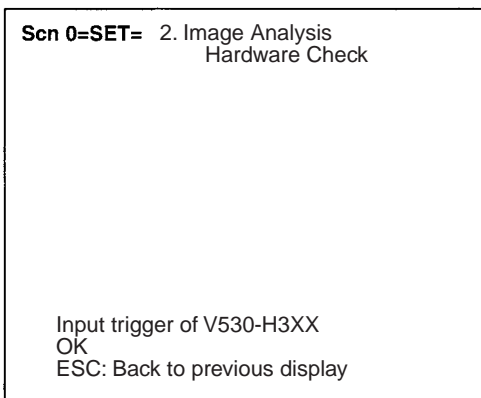

■ **Selecting Input Controller TRIG**

- 4. Input a trigger signal from external devices connected to the trigger terminal.

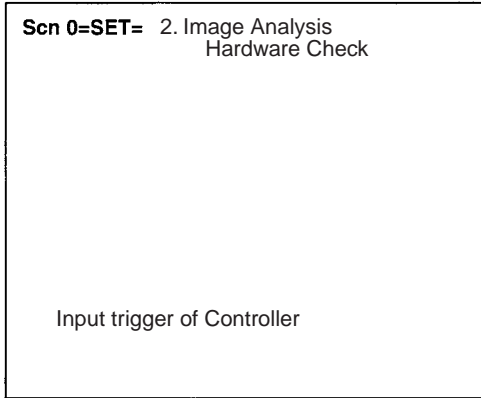

- 5. If "OK ESC: Back to previous display" is displayed on the screen, the hardware is normal. Press the ESC Key to return to step (3).

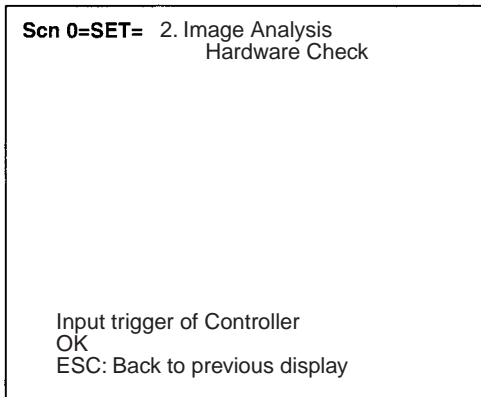

■ Selecting I/O SW1 to SW6

- 4. Following the instructions on the screen, turn ON each pin on the DIP switch individually with all other pins OFF. If all pins are okay, step (3) will be returned to automatically.

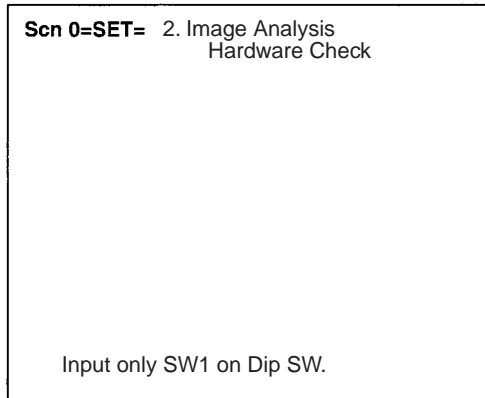

**Note** "SW1" in the above display will change to indicate what to turn ON next.

DIP Switch Settings for Hardware Check

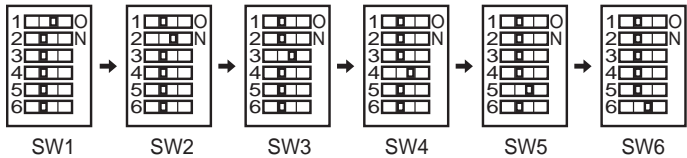

2. Image Analysis

— Contrast (Line Bright)

Used to check the contrast between the code and the background or between black cells and white cells. Low contrast will cause unstable reading. Adjust the lighting or settings if the contrast is too low.

- The display will be as follows if the line is within 45° of horizontal:

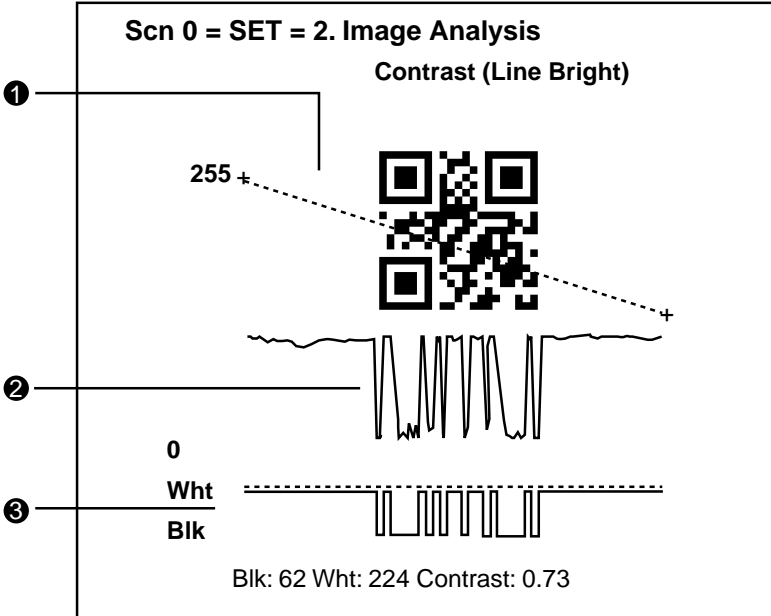



- The display will be as follows if the line is more than 45° off horizontal:

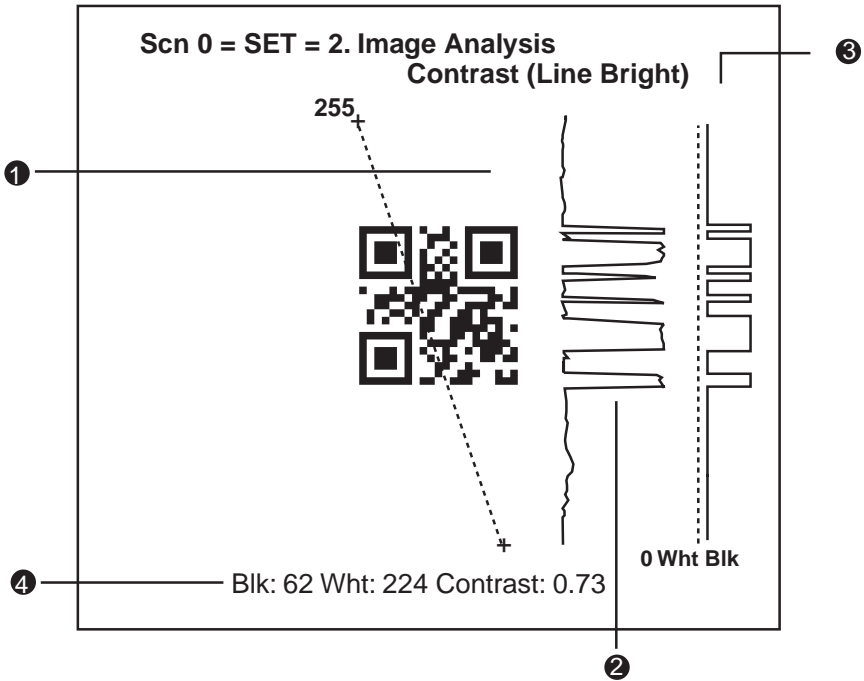

- 1,2,3...**
1. Specify the beginning and end point of the line for which density distribution is to be displayed.
  2. The density distribution is displayed.
  3. The ratio of black and white with respect to the gray edge value is displayed.
  4. The average densities of the black and white cells will be displayed along with the contrast (density ratio). The contrast will be displayed between 0.00 and 1.00. The larger the numeric value, the higher the contrast.

**Note** Analysis is not possible for through images.

Procedure

- 1,2,3... 1. Select **2. Image Analysis** and press the ENT Key.

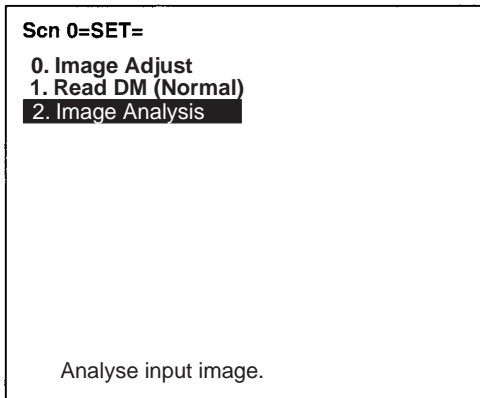

2. Select either **Line Bright X** or **Line Bright Y** as required and press the ENT Key.



3. Select the gray edge level for black and white judgment. (1 to 255)

Press the ENT Key to change the cursor to fill one digit or character. Use the Left/Right Keys to change line and use the Up/Down Keys to change the gray edge level.

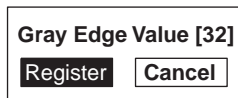

4. Select **Register**. The Line Bright screen will be displayed.
5. Move the cross cursor with the Up/Down/Left/Right Keys and press the ENT Key when the cursor is at the beginning point of the required line. Press the SHIFT Key together with the above keys to move the cursor faster.
6. Move the cross cursor with the Up/Down/Left/Right Keys and press the ENT Key when the cursor is at the end point of the required line.

The black pixel, white pixel, and contrast values will be displayed on the screen.

7. To change the location being displayed, press the ESC Key and repeat steps (5) and (6).
8. Press the ESC Key 3 times to end.

2. Image Analysis

— Contrast (Region)

Used to check the contrast between the code and the background or between black cells and white cells. Low contrast will cause unstable reading. Adjust the lighting or settings if the contrast is too low.

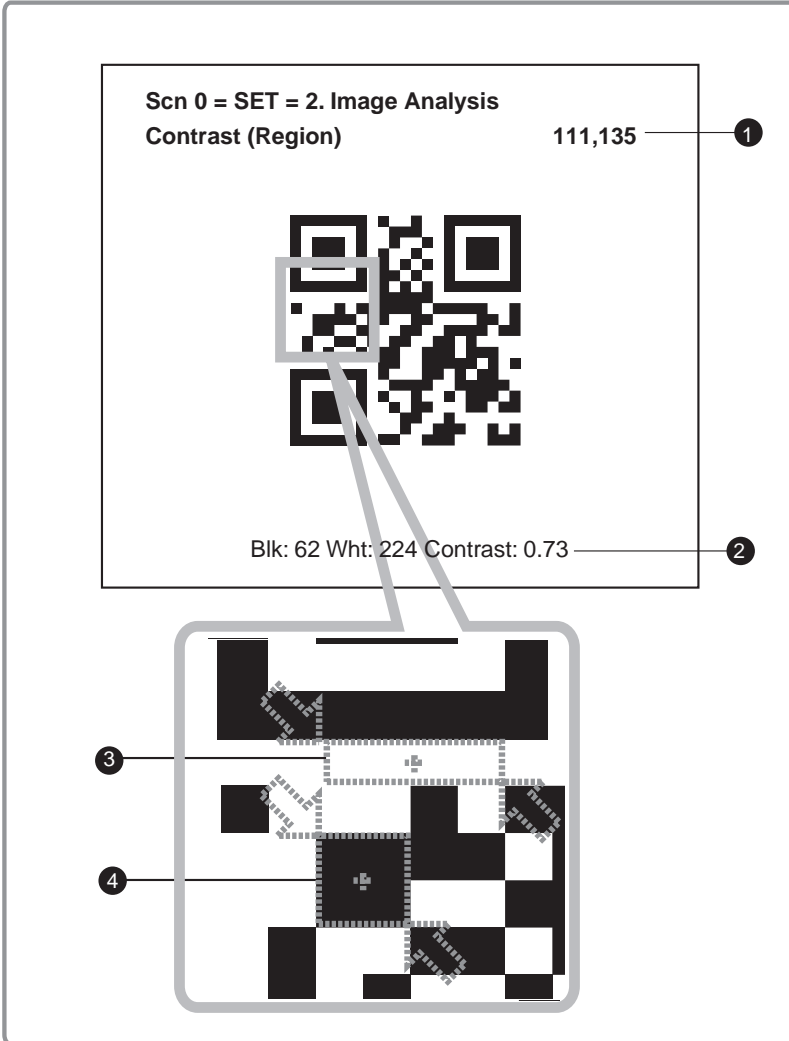

1,2,3... 1. Coordinates of the cursor.

2. The average densities of the black and white cells will be displayed along with the contrast (density ratio). The contrast will be displayed between 0.00 and 1.00. The larger the numeric value the higher the contrast.
3. Specified white cell region.
4. Specified black cell region.

**Note** Analysis is not possible on a through image.

### Procedure

- 1,2,3...** 1. Select **2. Image Analysis**.

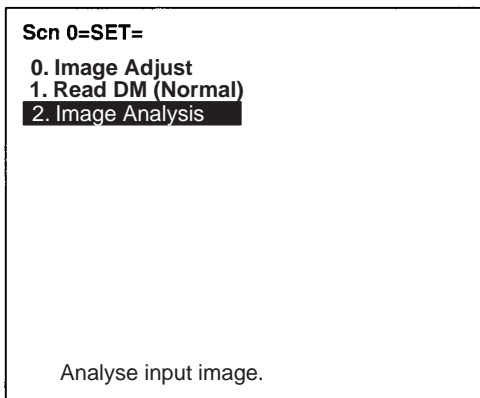

2. Select **Contrast (Region)**.

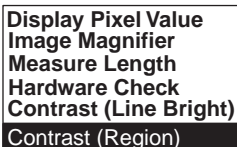

3. Move the cross cursor with the Up/Down/Left/Right Keys and press the ENT Key when the cursor is at upper left corner of the white region. Press the SHIFT Key together with the above keys to move the cursor faster
4. Move the cross cursor with the Up/Down/Left/Right Keys and press the ENT Key when the cursor is at lower right corner of the white region.
5. Specify the black region using the same procedure as was used for the white region.  
 The black pixel, white pixel, and contrast values will be displayed on the screen.
6. Press the ENT Key to return to step (2).

## 5-2 RUN Mode

Reading is performed under the setting conditions for the scene displayed.  
 Reading judgement and data are output to external devices.

### Procedure

- 1,2,3...**
1. Select RUN Mode.  
 Press the ESC Key from any other mode to automatically enter RUN Mode.

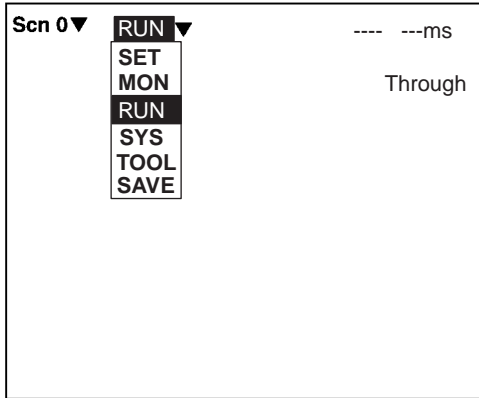

2. Input a reading trigger.
  - Scanner  
 One reading is performed by pressing the Trigger Switch once
  - Console  
 One reading is performed by pressing the TRIG Key once.
  - RS-232C **page 16**

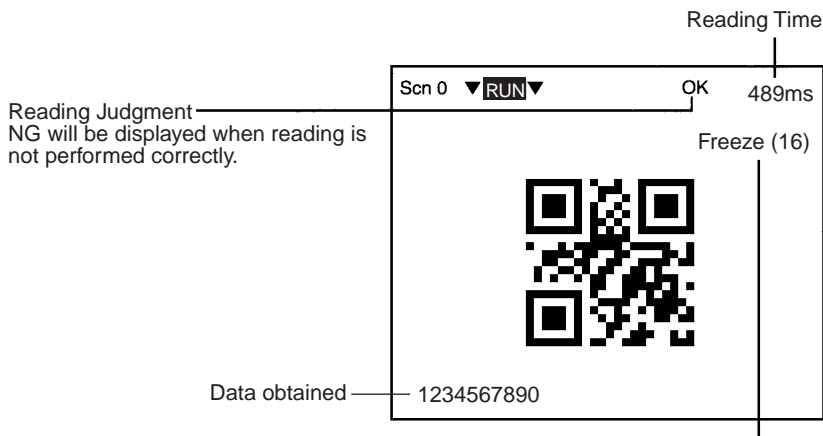

Displayed Images. Press the SHIFT + Up/Down Keys to switch images.

### Types of Displayed Image

Freeze (□)	A still image immediately after measurement. The memory number (0 to 23) under which the image is stored is displayed in □. When reading moving objects, display freeze images.
Through	<p>A live image from the Scanner. When reading is performed on through images, a delay of 33.3 ms max. (depending on timing of command inputs) will occur before starting to load images.</p>
Memory □	A reading image stored in the past. The reading images which are coincident with image storage conditions are stored in memory 0 to 23. How to set storage conditions of images. <b>page 110</b>
Image 0	An image after filtering according to the settings in <b>SET/Image Adjust</b> . Reading is performed on the image after filtering.
Image 1	An edge detection image for Data Matrix processing. (For a scene in which conditions are set for QR Codes, this will be same as the Image 0.)

**When Reading Data is ON:**

- OK: Reading data are displayed.
- NG: Error codes are displayed.

(e.g.) Reading OK





**When Detail Data is ON:**

Detailed data of reading codes are displayed.

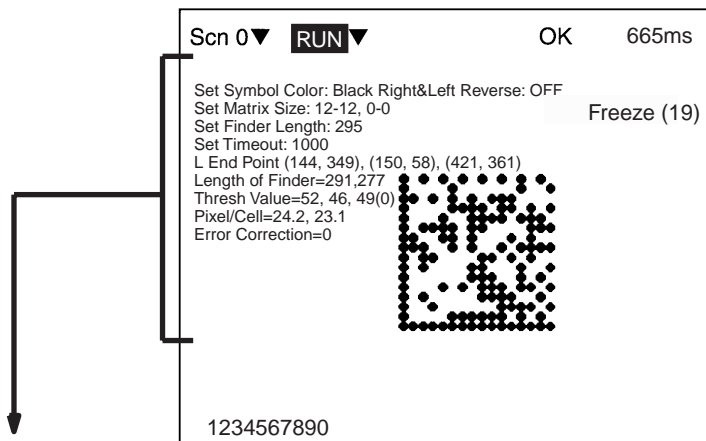

**QR Code (Normal or Pattern Mode)**

Set Symbol Color	Displays the setting of the symbol color.
Right&Left Reverse	Displays the setting of right & left reversal.
Set Gray Edge Value (Normal only)	Displays the setting of the gray edge value.
Set Gray Edge Retry Value (Normal only)	Displays the setting of the gray edge retry value.
Set Pixel Skipping (Pattern only)	Displays the setting for pixel skipping.
Set Correlation (Pattern only)	Displays the setting for correlation.
Set Version (Pattern only)	Displays the setting of the QR code version.
Set Timeout	Displays the setting of the timeout time.
Error Correction Level	Displays the error correction level read from the code.
Model	Displays the model read from the code.
Version	Displays the version of QR code read from the code.
Thresh Value	Displays the threshold value used for decoding.
Pixel/Cell	Displays the pixels/cells read from the code.
Error Correction	Displays the number of blocks for which error correction was performed when decoding.

**Data Matrix (Normal or Pattern Mode)**

Set Symbol Color	Displays the setting of the symbol color.
Right&Left Reverse	Displays the setting of right & left reversal.
Set Matrix Size	Displays the setting of the matrix size.
Set Finder Length (Normal only)	Displays the setting of the finder length.
Set Correlation (Pattern only)	Displays the setting for correlation.
Set Timeout	Displays the setting of the timeout time.
L End Point (Normal only)	Displays the coordinates of the end point of the finder.
Length of Finder	Displays the finder length found when decoding.

Thresh Value	Displays the threshold value used for decoding.
Pixel/Cell	Displays the pixels/cells read from the code.
Error Correction	Displays the number of blocks for which error correction was performed when decoding.

**When Finder Pattern is ON:**

A cross cursor will appear at the position recognized as a finder pattern.



**When Cell Position is ON:**

A cross cursor will appear at the position recognized as a cell.



## 5-3 System Mode

### 5-3-1 RS-232C Communications

#### SYS — Communications

Sets communications methods when communicating to external devices via terminal RS-232C.

A	Baud rate	:	38400bps	▼
B	Data length	:	8bit	▼
C	Parity bits	:	None	▼
D	Stop bits	:	1bit	▼
E	Header	:	None	▼
F	Footer	:	CR	▼
G	FCS	:	OFF	▼
H	Error Output	:	OFF	▼
I	Flow control	:	None	▼
J	Timeout	:	[ 5]s	

↑
↓
End

**1,2,3...**

1. Select 2400, 4800, 9600, 19200, or 38400 (bps). (Default setting: 38400)
2. Select 7 or 8 (bits). (Default setting: 8)
3. Select None, Odd, or Even. (Default setting: None)
4. Select 1 or 2 (bits). (Default setting: 1)
5. Select None, STX, or ESC. (Default setting: None)
6. Select CR, LF, or CR+LF. (Default setting: CR)
7. Select OFF or ON. (Default setting: OFF)
8. Select OFF or ON. (Default setting: OFF)
9. None: No flow control is performed (default).
  - RS/CS: Hardware flow control is performed. Prepare a cable to connect the RS and CS signals from the V530-C300E to the external device. Data will be sent when the CS signal from the external device is ON.
  - Xon/Xoff: Software flow control is performed. Data is sent according to the Xon/Xoff codes sent from the external device.
10. Set the time to generate a timeout error in seconds (Setting range: 1 to 120 s; default setting: 5 s)

- 1,2,3... 1. Select **RS-232C**.

Scn 0=SYS =

**System settings**

- RS-232C**
- Buzzer
- Image storage
- Version

Set communications methods of RS-232C.

2. Set the items.

Baud rate	:	38400bps	▼
Data length	:	8bit	▼
Parity bits	:	None	▼
Stop bits	:	1bit	▼
Header	:	None	▼
Footer	:	CR	▼
FCS	:	OFF	▼
Error Output	:	OFF	▼

↑ ↓

**End**

3. Select **End**.

### 5-3-2 Buzzer Setting

**SYS** — **Buzzer Setting**

Sets the buzzer ON time.

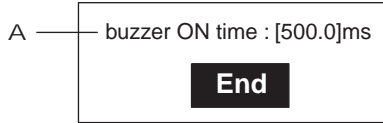

**1,2,3...**

1. Set the time that the buzzer is sounded. (Setting range: 1.0 to 1,000.0 ms; default setting: 500.0)  
Set the time to 1.0 ms to turn OFF the buzzer.)

**Procedure**

1. Select **Buzzer**.

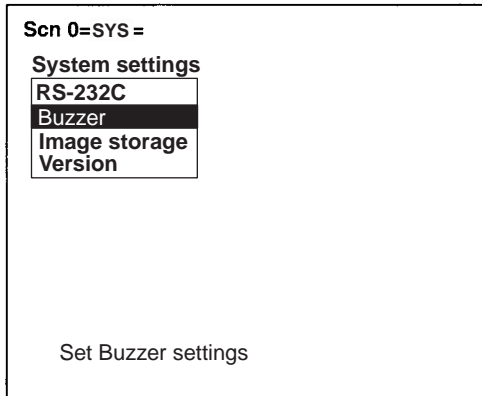

2. Set the time.

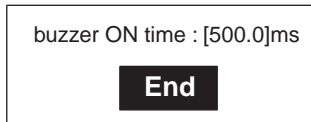

3. Select **End**.

### 5-3-3 Image Storage

#### SYS — Image storage

Selects whether to store the reading image or not. A maximum of 24 images can be stored.

**Note** The stored images are cleared when the power is turned OFF. Back up to a personal computer to keep the image data. **page 113**

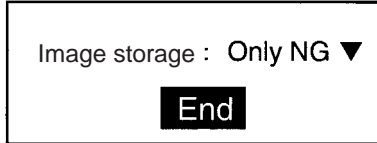

- 1,2,3...** 1. Select the conditions to store reading images.

None	No images are stored.
Only NG (Default setting)	Only NG (unreadable) images are stored.
All	All images are stored regardless of readable or unreadable.

#### Procedure

- 1,2,3...** 1. Select **Image Storage**.

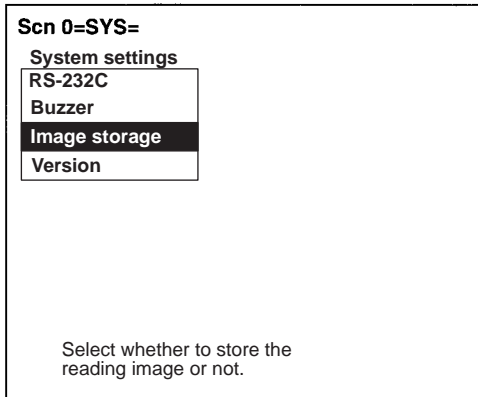

2. Select the conditions.

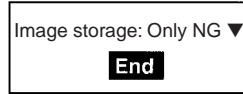

3. Select **End** before leaving this screen.

### 5-3-4 Version Information

**SYS** — **Version Information**

Displays the Model and software version.

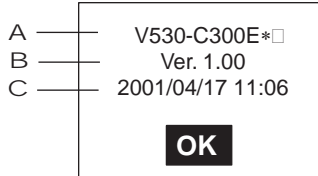

- 1,2,3...**
1. The model is displayed.
  2. The software version is displayed.
  3. The creation data is displayed.

#### Procedure

- 1,2,3...**
1. Select **Version**.  
The version information will be displayed.

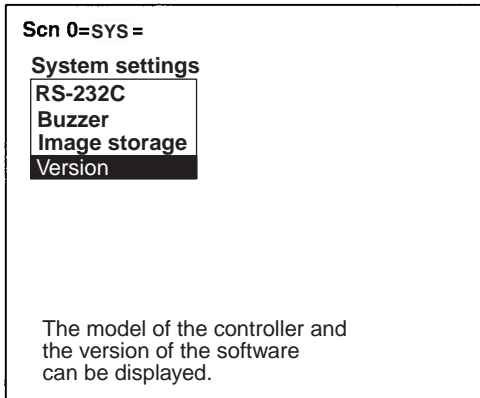

2. Select **OK** to leave this screen.





## 5-4 Tool Mode

The following four types of setting data can be backed up to a personal computer. This is a useful function for setting other devices with the same data. Backing up the setting data is recommended as a precaution against loss due to data damage or device malfunctions.

A	System data Load
B	System data Save
C	Scene data Load
D	Scene data Save
E	Sys + scn Load
F	Sys + scn Save
G	Image data Load
H	Image data Save

- 1,2,3...**
1. Loads the RS-232C, buzzer, and image storage settings under the system settings from the computer.
  2. Backs up the RS-232C, buzzer, and image storage settings under the system settings to the computer.
  3. Loads the SET mode settings from the computer.
  4. Backs up the items set in SET mode for each scene to the computer.
  5. Loads both the system settings and scene data (0 and 1) from the computer.
  6. Backs up both the system settings and scene data (0 and 1) to the computer.
  7. Loads bit map images to memory images from the computer.
  8. Backs up memory images to the computer as bit maps (\*.BMP). The images can be displayed on most computers because BMP is a common image format for Windows-based applications.

- Saving (Backup)



- Loading



**Note** Never turn OFF the power while saving or loading. Data may be lost, and the V530-C300E may not operate properly the next time it is started.

Procedure

- 1,2,3... 1. Select the item to be processed.

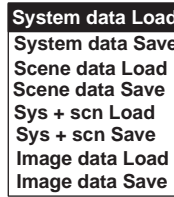

- 2. Select the scene or image when scene or image data has been selected.
  - Scenes (0 or 1)



- Images (Memory 0 to 23, Image 0 or 1)

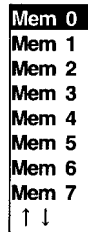

- 3. Select **Execute** when the confirmation message is displayed.

(e.g.) When saving system data:

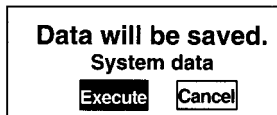

**Operation Examples for Personal Computers**

This section describes data transfer using the Hyper Terminal provided on Windows 95, 98, Me, 2000, and NT4.0 computers. In this example, a RS-232C cable is connected to the COM1 port of the computer. Alter the example to suit your communications software or COM port number. Data transfer is performed with XMODEM (-CRC or -SUM) protocol method.

**Note** Never turn OFF the power when processing messages for saving or loading operations are displayed. Data may be lost, and the V530-C300E may not operate properly the next time it is started.

### Saving Data to a Personal Computer (V530-C300E → Personal Computer)

#### Procedure

- 1,2,3...**
1. Connect the COM1 port on the computer and the V530-C300E using an RS-232 cable.
  2. Make the V530-C300E communication settings.

The default communication settings are as shown in the following table. These settings can be normally used.

Item	Setting
Baud rate	38400 (bps)
Data length	8 (bit)
Parity bits	None
Stop bits	1 (bit)
Footer	CR

3. Start the Hyper Terminal program on the computer and make the following communication settings.

The same communication settings must be used on both the V530-C300E and the modem on the computer.

Item	Setting
Baud rate (B)	38400 (bps)
Data length (D)	8 (bit)
Parity bits	None
Stop bits	1 (bit)
Flow control	None (XMODEM protocol is used.)

4. Save data from the V530-C300E.

The data transfer screen will be displayed.

**Scn 0=TOOL=**  
**Backup**

Saving data.

5. Select **Transfer/Receive File** from the Hyper Terminal menu.
  - Specify where the file is to be saved.
  - Set the protocol to **Xmodem**.
6. Select **Receive** and input the file name.  
 The data will be transferred from the V530-C300E to the computer.  
 The V530-C300E generates a timeout error if no response is received from the external device within 30 seconds. An error message will be displayed, and the error terminal will turn ON.

### Loading Data From the Computer (V530-C300E ← Personal Computer)

#### Procedure

- 1,2,3...** 1. Follow steps 1 to 3 in the above procedure to connect the V530-C300E and the computer.
2. Select **Transfer/Send File** from the Hyper Terminal menu.
  - Select the file to be loaded.
  - Set the protocol to **Xmodem**.
3. Select **Send**.  
 The data transfer screen will be displayed.
4. Load data with V530-C300E.  
 Data will be transferred from the computer to the V530-C300E.  
 The V530-C300E generates a timeout error if no response is received from the external device within 30 seconds. An error message will be displayed, and the error terminal will turn ON.

## 5-5 Scenes

The V530-C300E has 2 scenes.  
Set different reading conditions for each scene.

### Procedure

- 1,2,3...** 1. Display the basic screen.

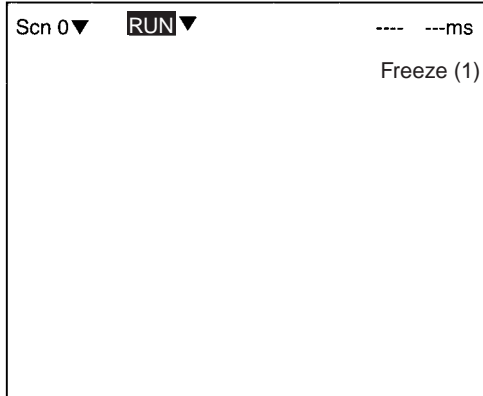

2. Move the cursor to **Scn 0** and press the ENT Key.

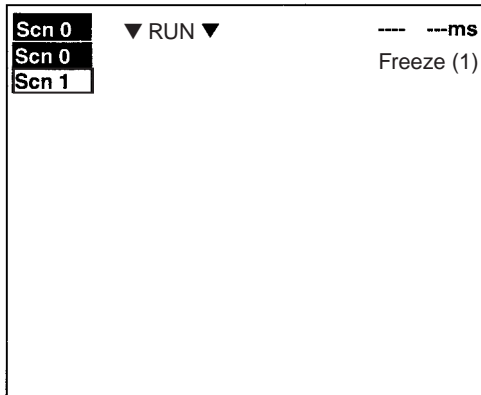

3. Move the cursor to **SCN 1** and press the ENT Key.

**Note** Communications commands can also be used to change the scene. Refer to page 134.

## Copying Scene Data

### Procedure

- 1,2,3...** 1. Move the cursor to the desired scene number and press the SHIFT+ ESC Keys.

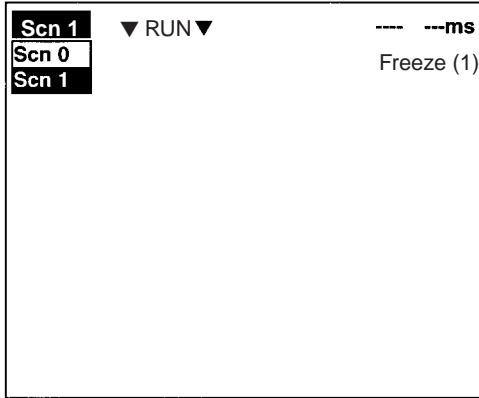

2. Select **Copy**.



3. Set the original scene number.  
Move the cursor to "Scn□▼" and press the ENT Key. A list of choices will be displayed. Move to the desired scene number using the Up/Down Keys and press the ENT Key.

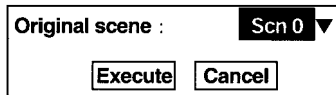

4. Select **Execute**.

## Clearing Scene Data

### Procedure

- 1,2,3... 1. Move the cursor to the scene number to be cleared and press the SHIFT + ESC Keys.

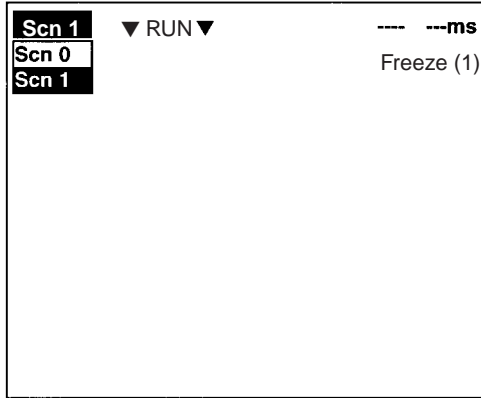

2. Select **Clear**.  
The confirmation message is displayed.



3. Select **Execute**.

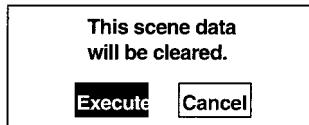

## 5-6 Saving to Flash Memory

Be sure to save revised setting data to flash memory before power is turned OFF.

As the V530-C300E loads data from flash memory at startup, any new data will be lost if it is not saved to flash memory. Also, images in RAM are cleared when power is turned OFF.

### Procedure

- 1,2,3...** 1. Display the basic screen.



2. Move the cursor to **MON** (monitor) and press ENT.

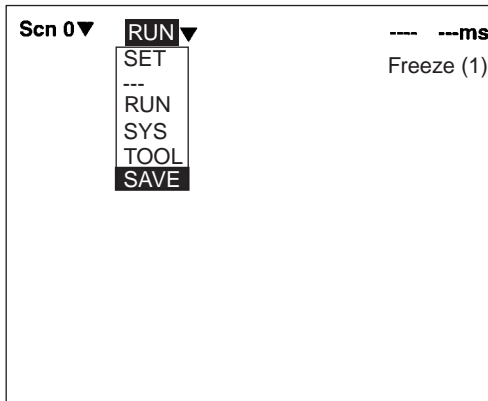

3. Select **SAVE**.



4. Select **Execute** when the confirmation message is displayed.  
When saving is completed, the screen in step 1 appears.

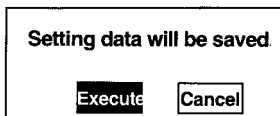

**Note** Never turn OFF the power when processing messages are displayed. Data may be lost, and the V530-C300E may not operate properly the next time it is started.



# SECTION 6

## Command Input and Output Formats

This section describes the formats used to input commands and output reading data.

6-1	Output Format . . . . .	124
6-2	Commands . . . . .	124
6-3	Error Codes . . . . .	125

## 6-1 Output Format

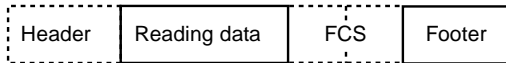

## 6-2 Commands

Function	Command	Page
Read Start Level Trigger	@GL	page 126
Start Continuous Read	@GC	page 127
Stop Continuous Read	@SC	page 127
Teach QR Code	@TQ <symbol color>	page 128
Teach Data Matrix	@TD <matrix size>	page 128
Load System Data via XModem	@YL	page 129
Save System Data via XModem	@YS	page 130
Load Scene Data via XModem	@CL	page 130
Save Scene Data via XModem	@CS	page 131
Load System + Scene Data via XModem	@AL	page 131
Save System + Scene Data via XModem	@AS	page 132
Load Image Data via XModem	@BL <memory number>	page 132
Save Image Data via XModem	@BS <memory number>	page 133
Change Scene	@SN	page 134
Save Settings	@SV	page 134
Read System Data via RS-232C	@YR	page 135
Write System Data via RS-232C	@YW	page 135
Read Scene Data via RS-232C	@CR	page 137
Write Scene Data via RS-232C	@CW	page 143
Read Communications Settings via RS-232C	@RR	page 144
Write Communications Settings via RS-232C	@RW	page 144
Read Buzzer Setting	@BR	page 145
Write Buzzer Setting	@BW	page 145
Read Image Storage Settings	@IR	page 146
Write Image Storage Settings	@IW	page 146
Read Version Information	@VR	page 147

## 6-3 Error Codes

- Outputting error codes can be enabled or disabled via a setting. Outputting is disabled by default. **page 107**
- If a reading is not completed successfully, an error code that indicates the cause of the error will be output. Refer to *Error Codes and Countermeasures* on page 166 for details.

### Error Codes for Normal or Pattern QR Codes

Error code	Meaning
E000	No finder patterns detected.
E001	Finder pattern detection error: Two Patterns were not detected.
E002	Finder pattern detection error: One pattern was not detected
E003	Finder pattern detection error: The relative positioning is incorrect.
E004	Finder pattern detection error: 4 or more finder patterns were detected.
E010	Decode error
E011	
E012	
E013	
E020	
E030	Pattern Search NG
E200	Timeout error

### Error Codes for Normal or Pattern Data Matrix

Error code	Meaning
E100	Finder pattern detection error: No candidate finder patterns.
E110	Finder pattern detection error: No finder patterns were detected.
E111	Finder pattern detection error: Only one finder pattern was detected.
E112	Finder pattern detection error: The relative positioning is incorrect.
E120	Decode error
E121	
E122	
E123	
E150	
E200	Timeout error

Error Codes for Pattern Data Matrix

Error code	Meaning
E160	Timing pattern detection error 1: No finder patterns were detected for models 1 or 2.
E161	Timing pattern detection error 2: 32 or more finder patterns were detected for models 1 or 2.
E170	Finder pattern detection error 1: No finder pattern was detected for model ABC.
E171	Finder pattern detection error 2: 32 or more finder patterns were detected for model ABC.
E172	Finder pattern detection error 3: Relative positioning is incorrect for model ABC.
E180	Decode error
E181	
E182	
E200	

- Items in dotted lines can be included or omitted by selecting them on RS-232C setting menus. **page 107.**

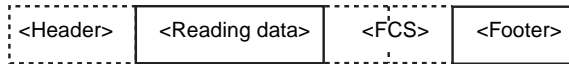

- Any empty box indicates that one space is required.

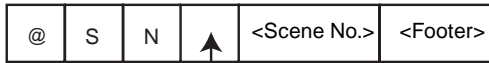

Insert one space.

**Read Start Level Trigger: @GL**

A read is performed. If reading is successful, reading is ended and the reading judgement is output.

Send



Receive

Reading OK

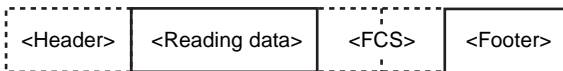

Reading NG

An error code is output if reading is not successful.

Note Outputting an error code can be disabled. **page 107**

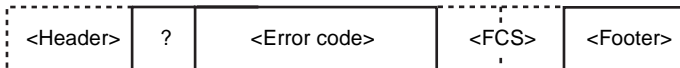

**Start Continuous Read: @GC**

**Stop Continuous Read: @SC**

Start and stop continuous reading. Reading will be performed continuously until @SC is received.

Send

Start Continuous Read Command

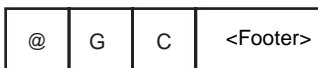

Receive

Reading OK

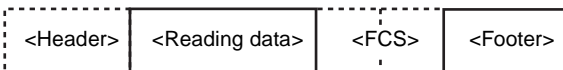

Reading NG

Note Outputting an error code can be disabled. **page 107**

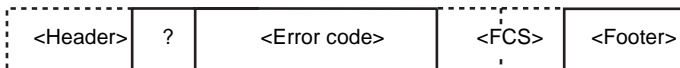

Send

Stop Continuous Read Command

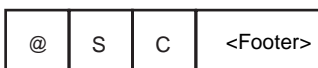

**Teach QR Code: @TQ**

Teaching is performed for normal QR codes. Optimum parameters will be set if teaching is successful. The parameters will not be changed if teaching is not successful. The normal data output format is used.

**Send**

**Teach QR Code Command**

@	T	Q		<Symbol color>	<Footer>
---	---	---	--	----------------	----------

Symbol Color

- B: Black
- W: White

**Receive**

**Teaching OK**

<Header>	<Reading data>	<FCS>	<Footer>
----------	----------------	-------	----------

**Teaching NG**

<Header>	?	<Error code>	<FCS>	<Footer>
----------	---	--------------	-------	----------

**Teach Data Matrix: @TD**

Teaching is performed for a normal data matrix. Optimum parameters will be set if teaching is successful. The parameters will not be changed if teaching is not successful. The normal data output format is used.

**Send**

**Teach Data Matrix Command**

@	T	D		<Matrix size 1>	<Matrix size 2>	<Footer>
---	---	---	--	-----------------	-----------------	----------

Matrix Size

- 10: 10×10
- 12: 12×12
- 14: 14×14
- 16: 16×16
- 18: 18×18



- 20: 20×20
- 22: 22×22
- 24: 24×24
- 26: 26×26

Receive

Teaching OK

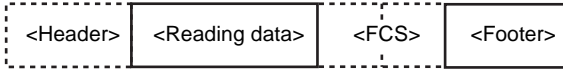

Teaching NG

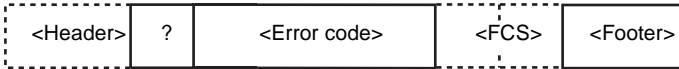

**Load System Data via XModem: @YL**

Loads system data using the XModem protocol. The V530-C300E will send “READY” to the external device when it is ready to load. Transfer the system data after receiving “READY”.

Send

Load System Data via XModem Command



Receive

Data Loaded Correctly

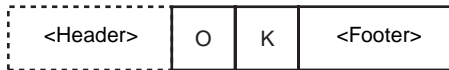

Data Not Loaded Correctly



**Save System Data via XModem: @YS**

Saves system data using the XModem protocol. The V530-C300E will send "READY" to the external device when it is ready to save. Transfer the system data after receiving "READY".

Send

**Save System Data via XModem Command**

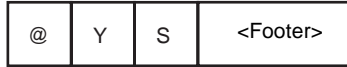

Receive

**Data Saved Correctly**



**Data Not Saved Correctly**



**Load Scene Data via XModem: @CL**

Loads scene data using the XModem protocol. The V530-C300E will send "READY" to the external device when it is ready to load. Transfer the scene data after receiving "READY".

Send

**Save Scene Data via XModem Command**



Receive

**Data Loaded Correctly**

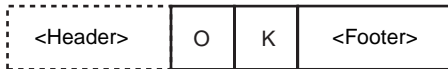

**Data Not Loaded Correct**



**Save Scene Data via XModem: @CS**

Saves scene data using the XModem protocol. The V530-C300E will send "READY" to the external device when it is ready to save. Transfer the scene data after receiving "READY".

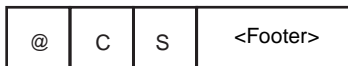
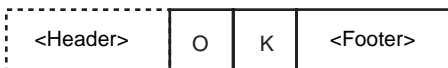
**Send****Save Scene Data via XModem Command****Receive****Data Saved Correctly****Data not Saved Correctly****Load System + Scene Data via XModem: @AL**

Loads system and scene data using the XModem protocol. The V530-C300E will send "READY" to the external device when it is ready to load. Transfer the system and scene data after receiving "READY".

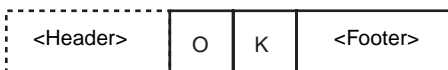
**Send****Load System + Scene Data via XModem Command****Receive****Data Loaded Correctly****Data Not Loaded Correctly**

**Save System + Scene Data via XModem: @AS**

Saves system and scene data using the XModem protocol.

The V530-C300E will send "READY" to the external device when it is ready to save. Transfer system and scene data after receiving "READY."

Send

**Save System + Scene Data via XModem Command**

@	A	S	<Footer>
---	---	---	----------

Receive

**Data Saved Correctly**

<Header>	O	K	<Footer>
----------	---	---	----------

**Data Not Saved Correctly**

<Header>	E	R	<Footer>
----------	---	---	----------

**Load Image Data via XModem: @BL**

Loads image data using the XModem protocol. The V530-C300E will send "READY" to the external device when it is ready to load. Transfer the image data after receiving "READY".

Send

**Load Image Data via XModem Command**

@	B	L		<Memory 1>	<Memory 2>	<Footer>
---	---	---	--	------------	------------	----------

Memory 1 and 2: Specify the image number as a 2-digit decimal number, e.g., specify storage memory 10 as follows:  
@BL<space>10.

Receive

**Data Loaded Correctly**

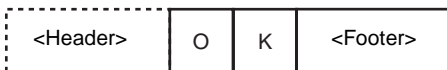

**Data Not Loaded Correctly**



**Save Image Data via XModem: @BS**

Saves image data using the XModem protocol.

The V530-C300E will send "READY" to the external device when it is ready to save. Transfer the image data after receiving "READY."

Send

**Save Image Data via XModem Command**

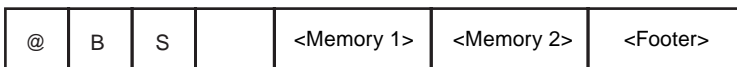

Memory 1 and 2: Specify the image number as a 2-digit decimal number, e.g., specify storage memory 10 as follows:

@BS<space>10.

Receive

**Data Saved Correctly**

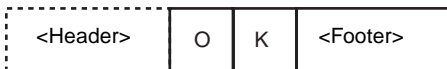

**Data Not Saved Correctly**



**Change Scene: @SN**

Changes the scene.

Send

**Change Scene Command**

@	S	N		<Scene No.>	<Footer>
---	---	---	--	-------------	----------

Scene No.

0: Scene 0

1: Scene 1

Receive

**Scene Change OK**

<Header>	O	K	<Footer>
----------	---	---	----------

**Scene Change NG**

<Header>	E	R	<Footer>
----------	---	---	----------

**Note** Scene numbers for the V530-C300E are 0 and 1.

**Save Settings: @SV**

Saves settings for system data and scene data.

Send

**Save Settings Command**

@	S	V	<Footer>
---	---	---	----------

Receive

**Save OK**

<Header>	O	K	<Footer>
----------	---	---	----------

**Save NG**

<Header>	E	R	<Footer>
----------	---	---	----------

**Read System Data via RS-232C: @YR**

The system data settings are output as numeric values

Send

**Load System Data via RS-232C Command**

@	Y	R	<Footer>
---	---	---	----------

Receive

**Reception OK**

<Header>	(1)	(2)	(3)	-----	(11)	(12)	<Footer>
----------	-----	-----	-----	-------	------	------	----------

**Note** Eighteen digits are set from (1) to (12).

**Write System Data via RS-232C: @YW**

Changes the system data settings. OK is output if the command is received normally; ER is output if the command is not received normally.

Send

**Save System Data via RS-232C Command**

@	Y	W		(1)	(2)	-----	(11)	(12)	<Footer>
---	---	---	--	-----	-----	-------	------	------	----------

**Note** Refer to the table of system data for settings (1) to (12). **page 136**

Receive

**Command Interpreted and Setting Items Match**

<Header>	O	K	<Footer>
----------	---	---	----------

**Command Interpreted and Setting Items Do Not Match**

<Header>	E	R	<Footer>
----------	---	---	----------

## Contents of System Data Commands

Area	Item	Number	Settings
RS-232C	Baud rate	(1)	0: 2,400 bps 1: 4,800 bps 2: 9,600 bps 3: 19,200 bps 4: 38,400 bps
	Data length	(2)	0: 7 bits 1: 8 bits
	Parity	(3)	0: None 1: Even 2: Odd
	Stop bits	(4)	0: 1 bit 1: 2 bits
	Header	(5)	0: None 1: STX 2: ESC
	Footer	(6)	0: CR 1: LF 2: CR+LF
	FCS	(7)	0: OFF 1: ON
	Error output	(8)	0: OFF 1: ON
	Flow control	(9)	0: None 1: RS/CS 2: Xon/Xoff
	Timeout	(10)	1 to 120 s (See note 1.)
Buzzer setting		(11)	1.0 to 1,000.0 ms (See note 2.)
Image storage method		(12)	0: None 1: Only NG 2: All

**Note**

- Expressed in 3 digits, e.g., 1 is expressed as 001.
- Expressed in 5 digits, e.g., 1000.0 is expressed as 10000 and 2.0 is expressed as 00020.
- There are 18 digits total for (1) to (12).  
Output example: 410000000005050001



### Read Scene Data via RS-232C: @CR

Reads scene data settings as numeric values. The scene data for the current scene set in the V530C300E is output. Change the scene to read out data for a different scene using the Scene Change command (@SN). Model registration is not performed and must be performed separately if required.

**Send**

**Read Scene Data via RS-232C**



**Receive**

**Normal QR Reading**



Refer to the table of normal QR reading contents for settings (1) to (12). **page 138**

**Pattern QR Reading**

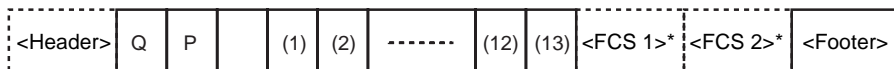

Refer to the table of pattern QR reading contents for settings (1) to (13). **page 139**

**Normal Data Matrix Reading**

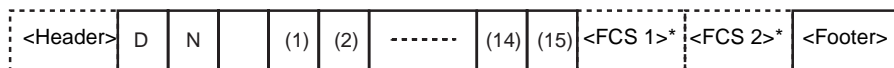

Refer to the table of normal data matrix reading contents for settings (1) to (15). **page 140**

**Pattern Data Matrix Reading**



Refer to the table of pattern data matrix reading contents for settings (1) to (13). **page 142**

**Nothing Registered**

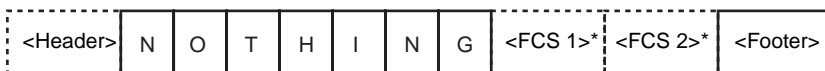

**Note** \*: Settings can be made to control whether or not items with asterisks are included.

## Normal QR Reading Contents

Area	Item	Number	Settings
Image input	Shutter speed	(1)	0: 1/250 s
			1: 1/500 s
			2: 1/1,000 s
	Background cut upper level (See note 1.)	(2)	1 to 255
	Background cut lower level (See note 1.)	(3)	0 to 254
Reading settings	Symbol color	(4)	0: Black
			1: White
	Right & left reverse	(5)	0: OFF
			1: ON
			2: Auto
Gray edge value (See note 1.)	(6)	1 to 127	
Gray edge value retry	(7)	0: OFF	
		1: ON	
Timeout (See note 2.)	(8)	200 to 2,000 ms	
Display settings	Reading data	(9)	0: OFF
			1: ON
	Detailed data	(10)	0: OFF
			1: ON
	Finder patten	(11)	0: OFF
			1: ON
Cell recognition position	(12)	0: OFF	
		1: ON	

- Note**
1. Expressed in 3 digits, e.g., 1 is expressed as 001.
  2. Expressed in 4 digits, e.g., 500 is expressed as 0500.
  3. There are 24 digits total for (1) to (12), including QN.  
Output example: QN 025500000032005000000

## Pattern QR Reading Contents

Area	Item	Number	Settings
Image input	Shutter speed	(1)	0: 1/250 s
			1: 1/500 s
			2: 1/1,000 s
3: 1/2,000 s			
	Background cut upper level (See note 1.)	(2)	1 to 255
	Background cut lower level (See note 1.)	(3)	0 to 254
Reading settings	Symbol color	(4)	0: Black
			1: White
	Right & left reverse	(5)	0: OFF
			1: ON
	Search pixel skipping (See note2.)	(6)	1 to 20
	Correlation (See note1.)	(7)	1 to 100
	Version	(8)	0: Version 1
1: Version 2			
2: Version 3			
3: Version 4			
			4: Version 5
			5: Version 6
	Timeout (See note 3).	(9)	200 to 2,000 ms
Display settings	Reading data	(10)	0: OFF
			1: ON
	Detailed data	(11)	0: OFF
			1: ON
	Finder patter	(12)	0: OFF
			1: ON
Cell recognition position	(13)	0: OFF	
		1: ON	

- Note**
1. Expressed in 3 digits, e.g., 1 is expressed as 001.
  2. Expressed in 2 digits, e.g., 1 is expressed as 01.
  3. Expressed in 4 digits, e.g., 500 is expressed as 0500.
  4. There are 26 digits total for (1) to (13), including QP.  
Output example: QP 02550000005050005000000

## Normal Data Matrix Reading Contents

Area	Item	Number	Settings
Image input	Shutter speed	(1)	0: 1/250 s
			1: 1/500 s
			2: 1/1,000 s
3: 1/2,000 s			
	Background cut upper level (See note 1.)	(2)	1 to 255
	Background cut lower level (See note 1.)	(3)	0 to 254
Reading settings	Symbol color	(4)	0: Black
			1: White
			2: Auto
	Right & left reverse	(5)	0: OFF
			1: ON
			2: Auto
	Matrix size 1 (See note 2.)	(6)	0: 10 x 10
			1: 12 x 12
			2: 14 x 14
			3: 16 x 16
			4: 18 x 18
			5: 20 x 20
			6: 22 x 22
			7: 24 x 24
	Matrix size 2 (See note 2.)	(7)	0: None
			1: 10 x 10
2: 12 x 12			
3: 14 x 14			
4: 16 x 16			
5: 18 x 18			
6: 20 x 20			
7: 22 x 22			
8: 24 x 24			
Free finder length	(8)	0: OFF	
		1: ON	
Finder length (See note 1.)	(9)	50 to 480	
Background cut	(10)	0: Weak	
		1: Middle	
		2: Strong	
Timeout time (See note 3.)	(11)	200 to 2,000 ms	

<b>Area</b>	<b>Item</b>	<b>Number</b>	<b>Settings</b>
Display settings	Reading data	(12)	0: OFF
			1: ON
	Detailed data	(13)	0: OFF
			1: ON
	Finder pattern	(14)	0: OFF
			1: ON
	Cell recognition position	(15)	0: OFF
			1: ON

- Note**
1. Expressed in 3 digits, e.g., 1 is expressed as 001.
  2. Expressed in 2 digits, e.g., 2 is expressed as 02.
  3. Expressed in 4 digits, e.g., 500 is expressed as 0500.
  4. There are 29 digits total for (1) to (15), including DN.  
Output example: DN 02550000003050150105000000

## Pattern Data Matrix Reading Contents

Area	Item	Number	Settings
Image input	Shutter speed	(1)	0: 1/250 s
			1: 1/500 s
			2: 1/1,000 s
	Background cut upper level (See note 1.)	(2)	1 to 255
	Background cut lower level (See note 1.)	(3)	0 to 254
Reading settings	Symbol color	(4)	0: Black
			1: White
	Right & left reverse	(5)	0: OFF
			1: ON
	Matrix size	(6)	0: 10 x 10
			1: 12 x 12
			2: 14 x 14
			3: 16 x 16
			4: 18 x 18
5: 20 x 20			
6: 22 x 22			
7: 24 x 24			
8: 26 x 26			
Display settings	Search pixel skipping (See note2.)	(7)	1 to 20
	Correlation (See note1.)	(8)	1 to 100
	Timeout (See note 3.)	(9)	200 to 2,000 ms
	Reading data	(10)	0: OFF
			1: ON
	Detailed data	(11)	0: OFF
			1: ON
Finder pattern	(12)	0: OFF	
		1: ON	
Cell recognition position	(13)	0: OFF	
		1: ON	

- Note**
1. Expressed in 3 digits, e.g., 1 is expressed as 001.
  2. Expressed in 2 digits, e.g., 1 is expressed as 01.
  3. Expressed in 4 digits, e.g., 500 is expressed as 0500.
  4. There are 27 digits total for (1) to (13), including DP.  
Output example: DP 025500000030505005000000

**Write Scene Data via RS-232C: @CW**

Changes the scene data settings.

**Send**

**Write Command for Normal QR Scene Data**

@	C	W		Q	N		(1)	(2)	-----	(11)	(12)	<Footer>
---	---	---	--	---	---	--	-----	-----	-------	------	------	----------

Refer to the table of normal QR reading contents for settings (1) to (12). **page 138**

**Write Command for Pattern QR Scene Data**

@	C	W		Q	P		(1)	(2)	-----	(12)	(13)	<Footer>
---	---	---	--	---	---	--	-----	-----	-------	------	------	----------

Refer to the table of pattern QR reading contents for settings (1) to (13). **page 139**

**Write Command for Normal Data Matrix Scene Data**

@	C	W		D	N		(1)	(2)	-----	(14)	(15)	<Footer>
---	---	---	--	---	---	--	-----	-----	-------	------	------	----------

Refer to the table of normal data matrix reading contents for settings (1) to (15). **page 140**

**Write Command for Pattern Data Matrix Scene Data**

@	C	W		D	P		(1)	(2)	-----	(12)	(13)	<Footer>
---	---	---	--	---	---	--	-----	-----	-------	------	------	----------

Refer to the table of pattern data matrix reading contents for settings (1) to (13). **page 142**

Model registration is not performed and must be performed separately if required.

**Receive**

**Command Interpreted and Setting Items Match**

<Header>	O	K	<Footer>
----------	---	---	----------

**Command Interpreted and Setting Items Do Not Match**

<Header>	E	R	<Footer>
----------	---	---	----------

**Read Communications Settings via RS-232C: @RR**

Outputs the settings in the system data as numeric values.

Send

**System Data Output Command**

@	R	R	<Footer>
---	---	---	----------

Receive

**Data Reception OK**

<Header>	(1)	(2)	(3)	-----	(9)	(10)	<FCS 1>*	<FCS 2>*	<Footer>
----------	-----	-----	-----	-------	-----	------	----------	----------	----------

- Note**
1. \*: Settings can be made to control whether or not items with asterisks are included.
  2. There is a total of 12 digits from (1) to (10). **page 136.**  
Output example: 410000000005

**Write Communications Settings via RS-232C: @RW**

Changes the settings in the system data.

Send

**System Data Change Command**

@	R	W		(1)	(2)	-----	(9)	(10)	<Footer
---	---	---	--	-----	-----	-------	-----	------	---------

Refer to the table of system data for settings (1) to (10). **page 136**

Receive

**Command Interpreted and Setting Items Match**

<Header>	O	K	<Footer>
----------	---	---	----------

**Command Interpreted and Setting Items Do Not Match**

<Header>	E	R	<Footer>
----------	---	---	----------



**Read Buzzer Setting: @BR**

Outputs the setting in the system data as a numeric value.

Send

**System Data Output Command**

@	B	R	<Footer>
---	---	---	----------

Receive

**Data Reception OK**

<Header>	(11)	<FCS 1>*	<FCS 2>*	<Footer>
----------	------	----------	----------	----------

- Note**
1. \*: Settings can be made to control whether or not items with asterisks are included.
  2. Refer to the table of system data for setting (11). **page 136**.  
Output example: 00500

**Write Buzzer Setting: @BW**

Changes the setting of the buzzer data.

Send

**System Data Change Command**

@	B	W		(11)	<Footer>
---	---	---	--	------	----------

Refer to the table of system data for setting (11). **page 136**.

Receive

**Command Interpreted and Setting Items Match**

<Header>	O	K	<Footer>
----------	---	---	----------

**Command Interpreted and Setting Items Do Not Match**

<Header>	E	R	<Footer>
----------	---	---	----------

**Read Image Storage Setting: @IR**

Reads the image storage method as a numeric value.

Send

**Read Image Storage Setting Command**

@	I	R	<Footer>
---	---	---	----------

Receive

**Data Reception OK**

<Header>	(12)	<FCS 1>*	<FCS 2>*	<Footer>
----------	------	----------	----------	----------

- Note**
1. \*: Settings can be made to control whether or not items with asterisks are included.
  2. Refer to the table of system data for setting (12). **page 136**  
Output example: 1

**Write Image Storage Setting: @IW**

Writes the image storage method.

Send

**Write Image Storage Setting Command**

@	I	W		(12)	<Footer>
---	---	---	--	------	----------

Refer to the table of system data for setting (12). **page 136**

Receive

**Command Interpreted and Setting Items Match**

<Header>	O	K	<Footer>
----------	---	---	----------

**Command Interpreted and Setting Items Do Not Match**

<Header>	E	R	<Footer>
----------	---	---	----------

**Read Version Information: @VR**

Reads the ROM version information.

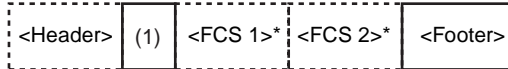
**Send****Read Version Information Command****Receive****Data Reception OK**

- Note**
1. \*: Settings can be made to control whether or not items with asterisks are included.
  2. The contents of (1) is as follows:  
Output example: V530-C300E Ver1.00 2001/04/01 12:00



# **SECTION 7**

## **Regular Inspections**

This section gives basic maintenance procedures and inspection items for the 2-Dimensional Code Reader.

To maintain the V530-C300E in the best condition, perform the following regularly.

- Lightly wipe off dirt with a soft cloth.
- Clean the lens and indicators with a cloth for a lens or air brush.

Inspection items	Details	Required tools
Power Supply	The voltage measured at the power supply terminals on the terminal block must be 24 VDC (+10%, -15%).	Circuit Tester
Ambient Temperature	The operating ambient temperature inside the cabinet must be between 0 to +38°C.	Thermometer
Ambient Humidity	The operating ambient humidity inside the cabinet must be between 35 to +85%.	Hygrometer
Installation	Each cable connector must be correctly inserted and locked.	Phillips screw driver

- Note**
1. Turn OFF the power and take safety precautions before conducting inspections.
  2. Do not use thinners or benzene.

# SECTION 8

## Specifications and Dimensions

This section gives specifications and dimensions for the component parts of the 2-Dimensional Code Reader.

8-1	2-Dimensional Code Reader . . . . .	152
8-2	Cables . . . . .	157
8-3	Console . . . . .	158
8-4	Monitors . . . . .	159
8-4-1	Video Monitor . . . . .	159
8-4-2	LCD Monitor . . . . .	160

# 8-1 2-Dimensional Code Reader

## V530-C300E Controller

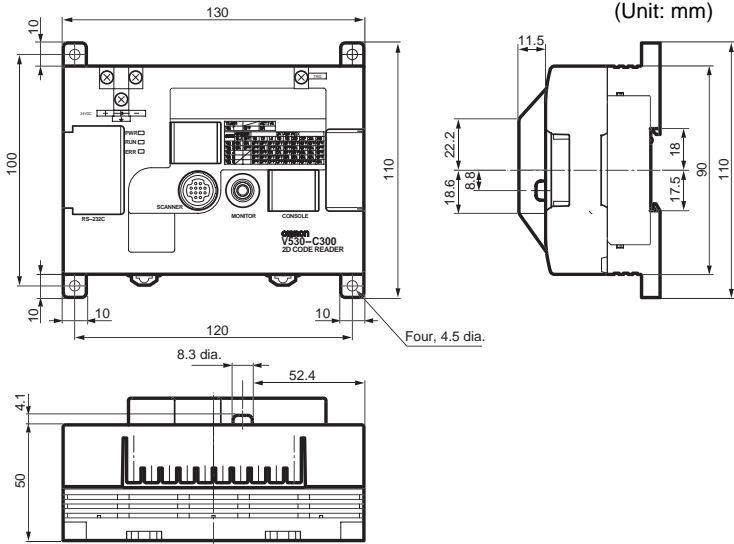

Item		V530-C300E specification
Performance	Applicable code	QR code (model 1.2): Version 1 to 6 (21 x 21 to 41 x 41) Data matrix (ECC200): 10 x 10 to 26 x 26
	Interface	RS-232C



	Item	V530-C300E specification
General specifications	Ambient temperature	Operating: 0 to 50°C; storage: -25 to 60°C (with no icing or condensation)
	Ambient humidity	Operating/storage: 35% to 85% (with no condensation)
	Ambient environment	No corrosive gases
	Power supply voltage	24 VDC (+10%/-15%)
	Current consumption	0.5 A
	Insulation resistance	20 MΩ min. between all DC external terminals and GR terminal (at 100 VDC, with internal surge absorber removed)
	Dielectric strength	1,000 VAC, 50/60 Hz between all DC external terminals and GR terminal (with internal surge absorber removed)
	Leakage current	10 mA max.
	Noise resistance (common mode)	1,500 Vp-p; pulse width: 0.1 μs/1 μs; rising time: 1 ns pulse (for combination of Controller and Scanner)
	Vibration resistance	10 to 150 Hz; half-amplitude: 0.35 mm (max. acceleration: 50 m/s <sup>2</sup> ), 4 times for 8 minutes each in 3 directions
	Shock resistance	150 m/s <sup>2</sup> , 3 times each in 6 directions
	Degree of protection	IEC60529 IP20
Weight		Approx. 500 g
Case material		ABS/PC

**V530-H301 Scanner (Reading Method: Coaxial Illumination)**

(Unit: mm)

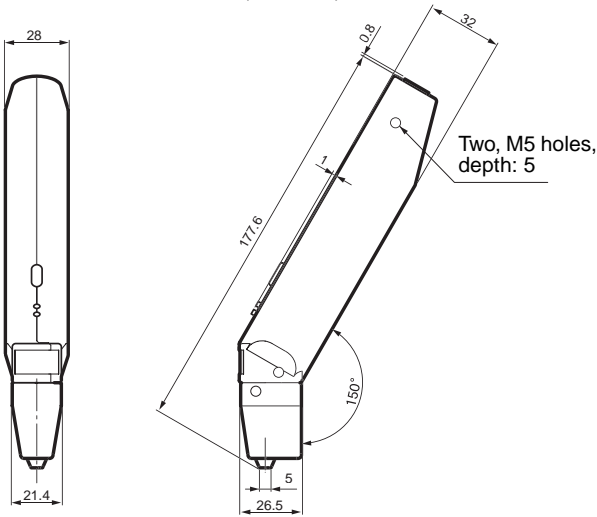

**V530-H302 Scanner (Reading Method: Oblique Illumination)**

(Unit: mm)

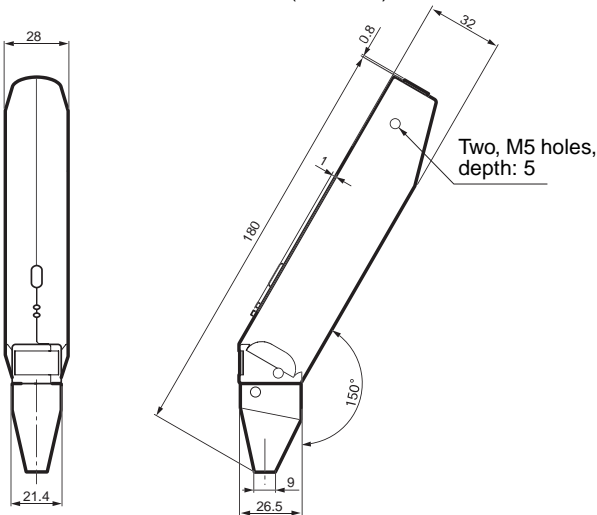

**V530-H303 Scanner (Reading Method: Transmissive Illumination)**

(Unit: mm)

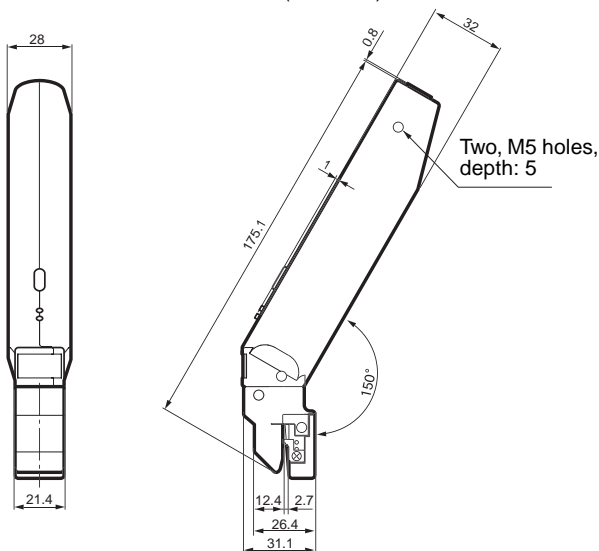

**Specifications**

Item		V530-H301	V530-H302	V530-H303
Performance	Applicable code	QR code (model 1.2): Version 1 to 6 (21 x 21 to 41 x 41) Data matrix (ECC200): 10 x 10 to 26 x 26		
	Field of view	3 x 3 mm	6 x 6 mm	6 x 6 mm
	Resolution	50 μm	100 μm	100 μm
	Illumination	Coaxial	Oblique	Backlight
	Reading method	Touch		

Item		V530-H301	V530-H302	V530-H303
General specifications	Ambient temperature	Operating: 0 to 38°C; storage: -25 to 60°C (with no icing or condensation)		
	Ambient humidity	Operating/storage: 35% to 85% (with no condensation)		
	Ambient environment	No corrosive gases		
	Insulation resistance	20 MΩ min. between all DC external terminals and GR terminal (at 100 VDC, with internal surge absorber removed)		
	Dielectric strength	1,000 VAC, 50/60 Hz between all DC external terminals and GR terminal (with internal surge absorber removed)		
	Leakage current	10 mA max.		
	Noise resistance (common mode)	1,500 Vp-p; pulse width: 0.1 μs/1 μs; rising time: 1 ns pulse (for combination of Controller and Scanner)		
	Vibration resistance	10 to 150 Hz; half-amplitude: 0.35 mm (max. acceleration: 50 m/s <sup>2</sup> ), 4 times for 8 minutes each in 3 directions		
	Shock resistance	150 m/s <sup>2</sup> , 3 times each in 6 directions		
	Degree of protection	IEC60529 IP20		
Weight		Approx. 100 g (without cable)		
Case Material		ABS (reading head: POM)		

## 8-2 Cables

### V530-W001 Scanner Cable

#### Specifications

Item	Specification
Vibration resistance	10 to 150 Hz; half-amplitude: 0.15 mm, 4 times for 8 minutes each in 3 directions
Shock resistance	196 m/s <sup>2</sup> , 3 times each in 6 directions
Ambient temperature	Operating: 0 to 50°C; storage: -25 to 65°C (with no icing or condensation)
Ambient humidity	Operating/storage: 35% to 85% (with no condensation)
Ambient environment	No corrosive gases
Length	2 m
Material	Cable shield: PVC
Minimum bending radius	75 mm

### F150VM Monitor Cable

#### Specifications

Item	Specification
Vibration resistance	10 to 150 Hz; half-amplitude: 0.15 mm, 4 times for 8 minutes each in 3 directions
Shock resistance	196 m/s <sup>2</sup> , 3 times each in 6 directions
Ambient temperature	Operating: 0 to 50°C; storage: -25 to 65°C (with no icing or condensation)
Ambient humidity	Operating/storage: 35% to 85% (with no condensation)
Ambient environment	No corrosive gases
Length	2 m
Material	Cable shield: Ultra flame-resistant vinyl chloride Connector: PVC
Minimum bending radius	50 mm

# 8-3 Console

## F150-KP

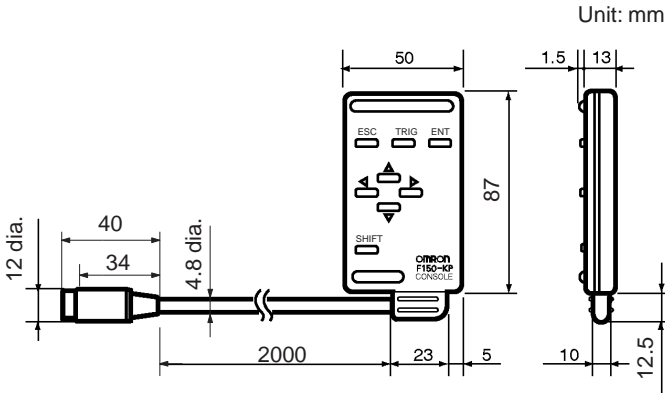

### Specifications

Item	Specification
Vibration resistance	10 to 150 Hz; half-amplitude: 0.15 mm, 4 times for 8 minutes each in 3 directions
Shock resistance	196 m/s <sup>2</sup> , 3 times each in 6 directions
Ambient temperature	Operating: 0 to 50°C; storage: -25 to 65°C (with no icing or condensation)
Ambient humidity	Operating/storage: 35% to 85% (with no condensation)
Ambient environment	No corrosive gases
Degree of protection	IEC60529 IP20 (in-panel)
Length	2 m
Minimum bending radius	75 mm
Material	Body: ABS Cable shield: Heat-resistant vinyl chloride Connector: PC, PBT
Weight	Approx. 135 g

## 8-4 Monitors

### 8-4-1 Video Monitor

#### F150-M09 (OMRON)

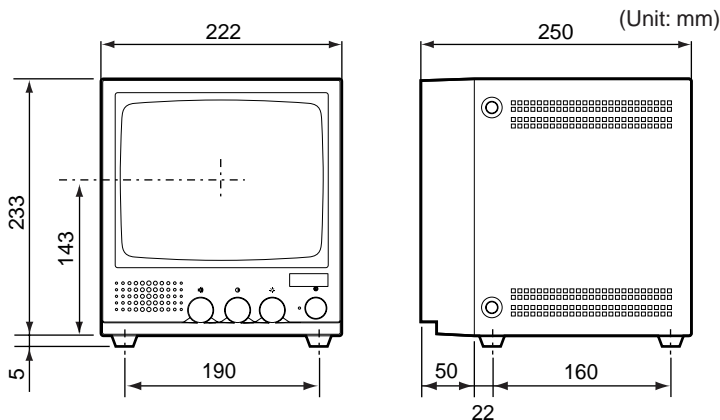

Item	Specification
Supply voltage	85 to 264 VAC, 50/60 Hz
Power consumption	Approx. 20 W max.
Vibration resistance	5 to 100 Hz; double-amplitude of 0.16 mm or acceleration of 7.35 m/s <sup>2</sup> (whichever is smaller), 6 times for 10 minutes each in 3 directions
Ambient temperature	Operating: -10 to 50°C; storage: -20 to 65°C (with no icing or condensation)
Ambient humidity	Operating/storage: 10% to 90% (with no condensation)
Ambient environment	No corrosive gases
Material	ABS Metal plates: SECC (zinc-plated steel sheet)
Panel size	9 inches; 164 x 123 mm (H x V)
Panel type	CRT, monochrome (long persistence)
Resolution	800 TV lines min. (at center)
System	Number of scanning lines: 600 Horizontal frequency: 15.75 kHz Field frequency: 60 Hz
I/O impedance	75 Ω, high impedance (selectable)
I/O level and polarity	Composite video signal: 1 Vp-p Image: 0.7 Vp-p, positive Synchronization: 0.3 Vp-p, negative

Item	Specification
Input signal	NTSC composite video (1.0 V/75 $\Omega$ termination)
Weight	Approx. 4.5 kg

## 8-4-2 LCD Monitor

### F150-M05L

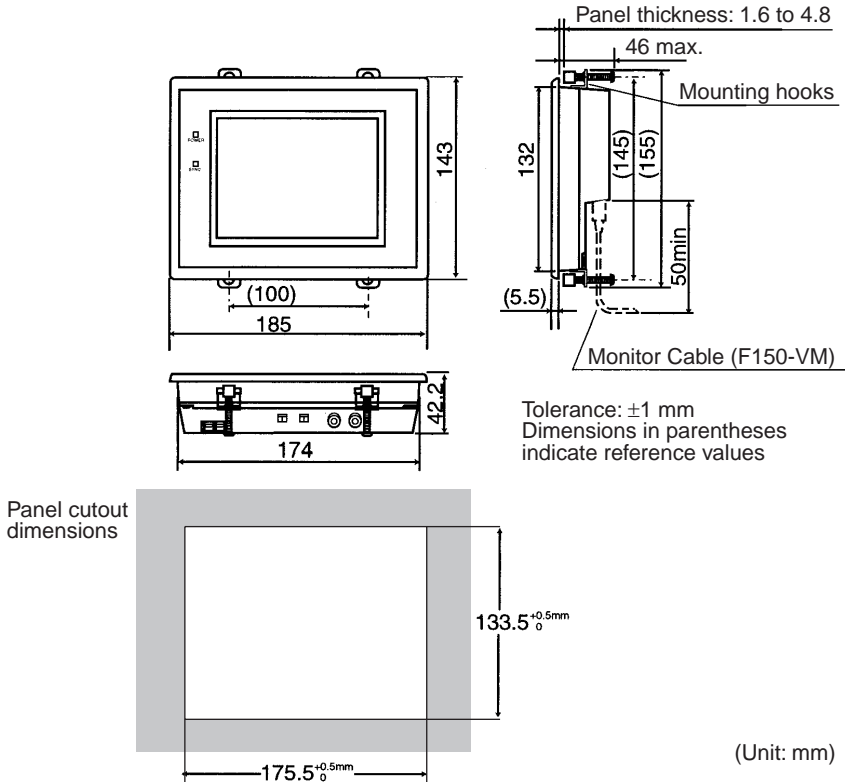

Item	Specification
Supply voltage	24 VDC (+10%/−15%)
Power consumption	15 W max.
Current consumption	700 mA max.
Vibration resistance	10 to 150 Hz; half-amplitude: 0.1 mm, 10 times for 8 minutes each in 3 directions
Shock resistance	150 m/s <sup>2</sup> , 3 times each in 6 directions
Ambient temperature	Operating: 0 to 50°C; storage: −25 to 65°C (with no icing or condensation)



Item	Specification
Ambient humidity	Operating/storage: 35% to 85% (with no condensation)
Ambient environment	No corrosive gases
Material	Case: ABS/PC Display: PMMA (acrylic)
Panel size	5.5 inches
Panel type	Liquid crystal color TFT
Resolution	320 × 240 dots
Image pitch	0.348 × 0.348 mm (H × V)
Image size	111.36 × 83.52 mm (H × V)
Contrast	83:1 (typical)
Viewable angle	25° up/down and 50° left/right (with a contrast ratio > 10)
Luminance	250 cd/m <sup>2</sup> (typical)
Backlight	Cold cathode fluorescent light
Response speed	60 ms max.
Input signal	NTSC composite video (1.0 V/75 Ω termination)
Weight	Approx. 1 kg



# SECTION 9

## Troubleshooting

This section details errors that may occur with the 2-Dimensional Code Reader and gives procedures for dealing with those errors.

9-1	Problems Reading Codes . . . . .	164
9-1-1	Workpieces. . . . .	164
9-1-2	Reading . . . . .	164
9-2	Error Codes and Countermeasures. . . . .	166
9-2-1	QR Code Reading (Normal or Pattern Mode)	166
9-2-2	Data Matrix Reading in Normal Mode	168
9-2-3	Data Matrix Reading in Pattern Mode	170
9-3	Troubleshooting . . . . .	171

## 9-1 Problems Reading Codes

### 9-1-1 Workpieces

Scanners	<p>Select the Scanner According to the workpiece, material and marking condition. <b>page 2</b></p> <ul style="list-style-type: none"> <li>• V530-H301 Scanner with Coaxial Illumination Ideal for codes marked on glossy or mirrored surfaces.             <ul style="list-style-type: none"> <li>• Resolution: 50 <math>\mu\text{m}</math></li> <li>• Field of vision: 3 x 3 mm</li> </ul> </li> <li>• V530-H302 Scanner with Oblique Illumination Ideal for codes marked on PWBs.             <ul style="list-style-type: none"> <li>• Resolution: 100 <math>\mu\text{m}</math></li> <li>• Field of vision: 6 x 6 mm</li> </ul> </li> <li>• V530-H303 Scanner with backlight Illumination Ideal for codes marked on glass or filters.             <ul style="list-style-type: none"> <li>• Resolution: 100 <math>\mu\text{m}</math></li> <li>• Field of vision: 6 x 6 mm</li> </ul> </li> </ul>
----------	--

### 9-1-2 Reading

#### Teaching

Check item	Countermeasure
Check that the code being read agrees with the DIP switch settings.	Set the DIP switch to agree with the code being read.
Check to be sure the reading operation is being performed.	The trigger may not be received if the DIP switch settings are incorrect when teaching. Set the DIP switch to agree with the code being read.

#### Settings

Check item	Countermeasure
Check to be sure the settings have been registered.	Except when teaching, a trigger will not be accepted unless the settings are registered.
Check that the following items match the code being read: <ul style="list-style-type: none"> <li>• Symbol color</li> <li>• Right &amp; Left Reverse</li> <li>• Code size (for Data Matrix reading in Normal mode)</li> <li>• Length of Finder (for Data Matrix reading in Normal mode)</li> <li>• Version (for QR Code reading in Pattern mode)</li> </ul>	Match the settings on the left to the reading code.

**Reading**

Check item	Countermeasure
Check that the code being read is within the field of vision.	Use a monitor to confirm that the code is in the field of vision before reading.
Check that the code is a 2-dimensional code consisting of cells exceeding the required resolution.	Use a code consisting of cells exceeding the required resolution.
Check that the code is marked properly.	Although an error correction function is supported, a code cannot be read if it exceeds the error correction ratio. If the code is not marked clearly enough, use clearer codes.
Check that the code is being picked up clearly.	Some workpieces are subject to the effects of hairlines, such as PWBs. If this occurs, change the angle of the workpiece or the angle of the scanner to reduce the effects of hairlines.  V530-H301 With coaxial illumination, the code may not be picked up at certain angles of the Scanner. Make sure the Scanner is perpendicular to the workpiece when reading.  V530-H302 Regular reflection of the illumination may affect reading. Use a monitor to make sure there is no regular reflection when reading.

**Margin**

Check item	Countermeasure
Check that there is a margin (white region) of 4 cells or more around the code.	Ensure there is a margin around the code.

**Others**

Check item	Countermeasure
Check error codes.	Turn ON the error code output and take countermeasures according to the error codes.

## 9-2 Error Codes and Countermeasures

### 9-2-1 QR Code Reading (Normal or Pattern Mode)

Error Code	Description	Countermeasures
E000	No finder patterns detected	No finder patterns were detected. <ul style="list-style-type: none"> <li>• Make sure that the image is displayed on the screen correctly.</li> <li>• Check the printing of the reading code. Three finder patterns in a corner may be stained or damaged.</li> </ul>
E001	Finder pattern detection error (Two patterns were not detected.)	Only one finder pattern was detected. (The other two patterns were not detected.) <ul style="list-style-type: none"> <li>• Check the printing of the reading code. Two finder patterns may be stained or damaged.</li> <li>• The position of finder patterns can be confirmed on the monitor when <b>Display Settings/Finder Pattern</b> is turned ON.</li> </ul>
E002	Finder pattern detection error (One pattern was not detected.)	Only two finder patterns were detected. (One pattern was not detected.) <ul style="list-style-type: none"> <li>• One finder pattern may be stained or damaged.</li> <li>• The position of finder patterns can be confirmed on the monitor when <b>Display Settings/Finder Pattern</b> is turned ON.</li> </ul>
E003	Finder pattern detection error (The relative positioning is incorrect.)	Three finder patterns were detected. However, the relative positioning of the three finder patterns is incorrect. <ul style="list-style-type: none"> <li>• The code may be bent or part of the finder patterns may be stained or damaged.</li> <li>• The position of finder patterns can be confirmed on the monitor when <b>Display Settings/Finder Pattern</b> is turned ON.</li> </ul>
E004	Finder pattern detection error (4 or more finder patterns were detected.)	Too many finder patterns (4 or more) were detected. <ul style="list-style-type: none"> <li>• Some of the finder patterns may be stained or damaged.</li> <li>• The position of finder patterns can be confirmed on the monitor when <b>Display Settings/Finder Pattern</b> is turned ON.</li> </ul>
E010	Decode error (Tentative version calculation error)	Finder patterns may be bent. Make sure that the image is loaded and at least 5 pixels per cell are displayed. <ul style="list-style-type: none"> <li>• The number of pixels of any section on a screen can be checked under <b>Image Analysis/Measure Length</b>.</li> </ul>
E011	Decode error (Format information error)	“Format information” in QR Codes may be stained or damaged. (Refer to the figure below.)
E012	Decode error	“Version information” in QR Codes is not correct.

Error Code	Description	Countermeasures
E013	Decode error (Cell recognition error)	Codes were restored to correct errors, but not decoded correctly. Data of QR Codes may be stained or damaged.
E020	Decode error (No definition error)	The printing is in a special format and not defined for the V530-C300E (connection mode, etc.). Change the printing format.
E030	Pattern search NG	As a result of the pattern search, 32 or more proposed finder patterns were found. Make sure the image is displayed on the monitor correctly and check the registered mode.
E200	Timeout error	Decoding was not possible within the timeout time. <ul style="list-style-type: none"> <li>• Redo teaching or re-register the pattern to obtain suitable setting.</li> <li>• Increase the timeout time.</li> </ul>

**Confirming Pixels Per Cell**

When **Display Settings/Detail Data** is turned ON, the number of pixels per cell is displayed together with detail information if reading is OK. When reading is NG, confirm the number of pixels per cell under **2. Image Analysis/Measure Length**.

**QR Codes**

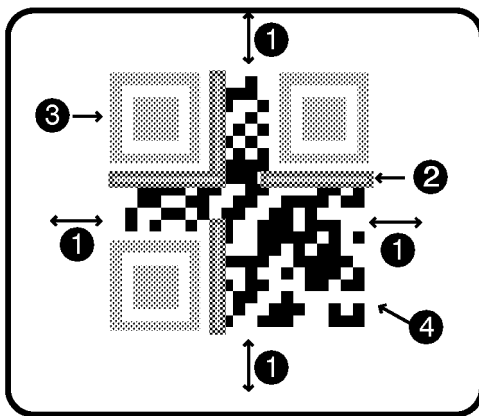

**1,2,3...**

1. A margin of 4 or more cells around the code is required.
2. Format information of the code. (  There are four.)
3. Finder patterns (Symbols in three corners)
4. Parts other than 1 to 3 are data.

## 9-2-2 Data Matrix Reading in Normal Mode

Error Code	Description	Countermeasures
E100	Finder pattern detection error (No candidate finder patterns)	No finder patterns were detected. <ul style="list-style-type: none"> <li>• Make sure that the image is displayed on the monitor correctly.</li> <li>• Check the printing of the reading code. The L-shaped finder pattern may be stained or damaged.</li> </ul>
E110	Finder pattern detection error (No finder patterns were detected.)	No finder patterns were detected. <ul style="list-style-type: none"> <li>• Make sure that the image is displayed on the monitor correctly.</li> <li>• Check the printing of the reading code. The L-shaped finder pattern may be stained or damaged.</li> </ul>
E111	Finder pattern detection error (Only one finder pattern was detected.)	Only one line of finder patterns was detected. <ul style="list-style-type: none"> <li>• Make sure the image is displayed on the monitor correctly. Check the printing of the reading code.</li> <li>• One of the L-shaped finder patterns may be stained or damaged.</li> <li>• The position of finder patterns can be confirmed on the monitor when <b>Display Settings/Finder Pattern</b> is turned ON.</li> </ul>
E112	Finder pattern detection error (The relative positioning is incorrect.)	Two finder patterns (two lines) were detected. However, the relative positioning of the patterns is incorrect. <ul style="list-style-type: none"> <li>• The codes may be bent or part of the finder patterns may be stained or damaged.</li> <li>• The L length (the length of finder patterns) set may be too long. Parameters can be set automatically using the teaching function.</li> </ul>
E120	Decode error (Timing pattern detection error)	Check the printing of the reading codes. <ul style="list-style-type: none"> <li>• The timing patterns in the X or Y directions may be stained or damaged.</li> <li>• The matrix size may not be set correctly. The L length (the length of finder patterns) set may be too short. Parameters can be set automatically using the teaching function.</li> </ul>
E121	Decode error (Timing pattern detection error in X direction)	Check the printing of the reading code. <ul style="list-style-type: none"> <li>• The timing pattern in the X direction may be stained or damaged.</li> <li>• Codes may be bent.</li> </ul>
E122	Decode error (Timing pattern detection error in Y direction)	Check the printing of the reading code. <ul style="list-style-type: none"> <li>• The timing pattern in the Y direction may be stained or damaged.</li> <li>• Codes may be bent.</li> </ul>
E123	Decode error (Cell recognition error)	Codes were restored to correct errors, but not decoded correctly. Part of the codes may be stained or damaged.



Error Code	Description	Countermeasures
E150	Decode error (No definition error)	The printing is in a special format and not defined for the V530-C300E. <ul style="list-style-type: none"> <li>• Change the printing format.</li> <li>• The codes may be bent, stained, or damaged.</li> </ul>
E200	Timeout error	Decoding was not possible within the timeout time. <ul style="list-style-type: none"> <li>• Redo teaching or re-register the pattern to obtain suitable setting.</li> <li>• Increase the timeout time.</li> </ul>

### Confirming Pixels Per Cell

When **Display Settings/Detail Data** is turned ON, the number of pixels per cell is displayed together with detail information in RUN mode. When reading is NG, confirm the number of pixels per cell under **2. Image Analysis/Measure Length**.

### Data Matrix

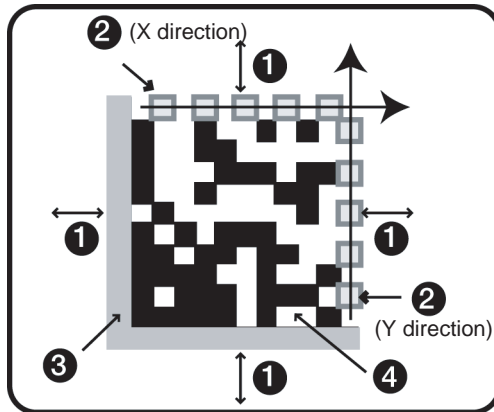

- 1,2,3...**
1. A margin of 4 or more cells around the code is required.
  2. Timing patterns (The cross point between black and white.)
  3. The L-shape in the corner is a finder pattern.
  4. Parts other than 1 to 3 are data.

## 9-2-3 Data Matrix Reading in Pattern Mode

Error Code	Description	Countermeasures
E160	Timing pattern detection error 1 (No finder patterns were detected for models 1 or 2)	<p>No timing pattern was detected.</p> <ul style="list-style-type: none"> <li>• The timing pattern may be stained or damaged. Check the condition of the timing pattern.</li> <li>• The correlation value may be too high. Decrease the correlation value.</li> <li>• A model may not be registered. Confirm that a model is registered.</li> <li>• A model may have been registered with an incorrect code size. Re-register the model.</li> </ul>
E161	Timing pattern detection error 2 (32 or more finder patterns were detected for models 1 or 2)	<p>Too many timing patterns (32 or more) were detected.</p> <ul style="list-style-type: none"> <li>• The correlation value may be too low. Increase the correlation value.</li> </ul>
E170	Finder pattern detection error 1 (No finder pattern was detected for model ABC)	<p>No finder pattern was detected.</p> <ul style="list-style-type: none"> <li>• The finder pattern may be stained or damaged. Check the condition of the finder pattern.</li> <li>• The correlation value may be too high. Decrease the correlation value.</li> <li>• A model may not be registered. Confirm that a model is registered.</li> <li>• A model may have been registered with an incorrect code size. Re-register the model.</li> <li>• Model registration may not have been performed in the optimum way. Re-register the model with reference to page 65.</li> </ul>
E171	Finder pattern detection error 2 (32 or more finder patterns were detected for model ABC)	<p>Too many finder patterns (32 or more) were detected.</p> <ul style="list-style-type: none"> <li>• The correlation value may be too low. Increase the correlation value.</li> <li>• Model registration may not have been performed in the optimum way. Re-register the model with reference to page 65.</li> </ul>
E172	Finder pattern detection error 3 (Relative positioning is incorrect for model ABC)	<p>3 points of the finder pattern were detected. However, the relative positioning of the patterns is incorrect.</p> <ul style="list-style-type: none"> <li>• The finder pattern may be stained or damaged. Check the condition of the finder pattern.</li> <li>• The correlation value may be too high. Decrease the correlation value.</li> <li>• Model registration may not have been performed in the optimum way. Re-register the model with reference to page 65.</li> </ul>

Error Code	Description	Countermeasures
E180 E181 E182	Decode error	<p>An L-shape finder pattern was detected but the data could not be decoded.</p> <ul style="list-style-type: none"> <li>• The data part of the code may be stained or damaged. Check the condition of the data part of the code.</li> <li>• The finder pattern may be stained or damaged. Check the condition of the finder pattern.</li> <li>• Model registration may not have been performed in the optimum way. Re-register the model with reference to page 65.</li> <li>• The cell recognition coordinates may be incorrect. Adjust the field of vision so that the code image is larger and re-enter the settings.</li> </ul>
E200	Timeout error	<p>Decoding was not possible within the timeout time.</p> <ul style="list-style-type: none"> <li>• Redo teaching or re-register the pattern to obtain suitable setting.</li> <li>• Increase the timeout time.</li> </ul>

**Common Check Items for Error Codes E160 to E182**

- Check that the orientation of the code is within  $\pm 10^\circ$ .
- Check that the code size is set correctly.
- Check that the model has been registered correctly using the **Reference Model** procedure given on page 65.

## 9-3 Troubleshooting

### Connection Errors

**The power indicator is not lit.**

- The power supply is not connected properly.
- The supply voltage is not 24 VDC+10%/–15%.

**The RUN indicator is not lit.**

- The cable is not connected correctly. (Use **Image Analysis/ Hardware Check** to confirm.)

**The OK indicator is not lit.**

- The cable is not connected correctly. (Use **Image Analysis/ Hardware Check** to confirm.)
- Teaching has not been performed.
- Use a monitor to be sure the code is picked up by the Scanner.

## **Scanner**

### **The trigger cannot be input.**

- The cable is not connected correctly. (Use **Image Analysis/Hardware Check** to confirm.)

### **Cannot make key inputs from the Console.**

- The Console cable is not correctly connected.

### **The monitor is blank.**

- The power of the monitor is not ON.
- The monitor cable is not connected properly.
- The monitor is malfunctioning.
- The power supply is not sufficient for the LCD monitor (when the LCD monitor is used).

### **The images on the monitor are not clear.**

- There is electrical noise entering from the power supply or cables.
- The monitor cable is not correctly connected.

### **The images on the monitor are hard to read.**

- Using the displayed error code and referring to *Error Codes and Countermeasures* on page 166, adjust the settings, Scanner, and illumination.

## **Errors During Menu Operation**

### **The reading results are not displayed on the monitor.**

- The V530-C300E is not in RUN mode.

## **Terminal Block Errors**

### **Trigger signals (input signals) are not received.**

- The cables are not correctly wired.
- The signal line is disconnected.
- The V530-C300E is not in RUN mode.

## **RS-232C Communications Errors**

### **No communications are possible.**

- The cables are not correctly wired.
- The communications specifications of the V530-C300E do not match those of the external device.
- The V530-C300E is not in RUN mode.

**Initially communications are possible, but the response from the V53-C300E stops after a while.**

- The buffer in the computer receiving data is full. Check to be sure that the computer is receiving data properly.



# Appendix A

## ASCII Codes

Character	Data (Hexadecimal No.)	Character	Data (Hexadecimal No.)	Character	Data (Hexadecimal No.)	Character	Data (Hexadecimal No.)
NUL	00	SP	20	@	40	'	60
SOH	01	!	21	A	41	a	61
STX	02	"	22	B	42	b	62
ETX	03	#	23	C	43	c	63
EOT	04	\$	24	D	44	d	64
ENQ	05	%	25	E	45	e	65
ACK	06	&	26	F	46	f	66
BEL	07	'	27	G	47	g	67
BS	08	(	28	H	48	h	68
HT	09	)	29	I	49	i	69
LF	0A	*	2A	J	4A	j	6A
VT	0B	+	2B	K	4B	k	6B
FF	0C	,	2C	L	4C	l	6C
CR	0D	-	2D	M	4D	m	6D
S0	0E	.	2E	N	4E	n	6E
S1	0F	/	2F	O	4F	o	6F
DLE	10	0	30	P	50	p	70
DC1	11	1	31	Q	51	q	71
DC2	12	2	32	R	52	r	72
DC3	13	3	33	S	53	s	73
DC4	14	4	34	T	54	t	74
NAK	15	5	35	Y	55	u	75
SYN	16	6	36	V	56	v	76
ETB	17	7	37	W	57	w	77
CAN	18	8	38	X	58	x	78
EM	19	9	39	Y	59	y	79
SUB	1A	:	3A	Z	5A	z	7A
ESC	1B	;	3B	[	5B	{	7B
FS	1C	<	3C	\	5C		7C
GS	1D	=	3D	]	5D	}	7D
RS	1E	>	3E	^	5E	(~)	7E
US	1F	?	3F	-	5F	DEL	7F





# Appendix B

## FCS Check Program

### Examples (BASIC)

#### Calculation Examples for Sending FCS

DATA\$	Sample Data Line
L	Data Length
CODE\$	Data Character
A	Exclusive Operation

```

100 *****CALCULATE FCS*****
110 *FCSSET
120 L=LEN(DATA$)
130 A=0
140 FOR J=1 TO L
150 CODE$=MID$(DATA$,J,1)
160 A=ASC(CODE$)XOR A
170 NEXT J
180 FCS$=HEX$(A)
190 IF LEN(FCS$)=1 THEN FCS$="0"+FCS$
200 RETURN

```

#### FCS Check Sub Routine Examples for Received Data

```

1000 *****FCSHECK*****
1010 *FCSHECK
1020 Q=0:FCCK$="OK"
1030 PRINT RESPONSE $
1040 LENG$=LEN(RESPONSE$)-3
1050 FCSP$=MID$(RESPONSE$,LENG$+1,2) .....Response Data of FCS
1060 FOR J=1 TO LENG$ .....Calculation Range of FCS
1070 Q=ASC(MID$(RESPONSE$,J,1))XOR Q
1080 NEXT J
1090 FCSD$=HEX$(Q)
1100 IF LEN(FCSD$)=1 THEN FCSD$="0"+FCSD$ .FCS calculated in a program
1110 IF FCSD$ < > FCSP$ THEN FCCK$="ERR"
1120 PRINT "FCSD$=";FCSD$;"FCSP$=";FCSP$;
"FCCK$=";FCCK$; .....FCS correctly received :OK
1130 RETURN          FCS not received correctly:ERR

```



# Appendix C

## Data Capacity Tables

### QR Code

#### QR Code (Model 2)

The relation between matrix size (number of cells) and data capacity is shown in the table below.

In this example, the matrix size is  $21 \times 21$  cells.

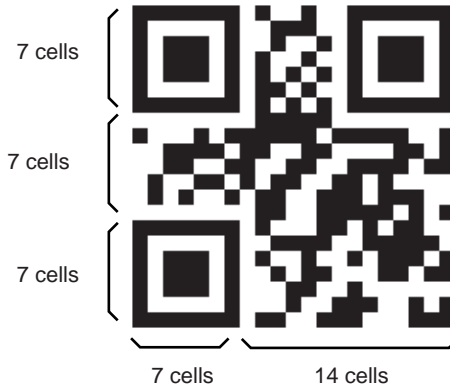

Matrix size (Version)	Error correction level	Data capacity			Matrix size (Version)	Error correction level	Data capacity		
		Num. Cap.	Alpha Num. Cap.	8-bit binary			Num. Cap.	Alpha Num. Cap.	8-bit binary
<b>21 × 21</b> (Version 1)	L (7%)	41	25	17	<b>33 × 33</b> (Version 4)	L (7%)	187	114	78
	M (15%)	34	20	14		M (15%)	149	90	62
	Q (25%)	27	16	11		Q (25%)	111	67	46
	H (30%)	17	10	7		H (30%)	82	50	34
<b>25 × 25</b> (Version 2)	L (7%)	77	47	32	<b>37 × 37</b> (Version 5)	L (7%)	255	154	106
	M (15%)	63	38	26		M (15%)	202	122	84
	Q (25%)	48	29	20		Q (25%)	144	87	60
	H (30%)	34	20	14		H (30%)	106	64	44

Matrix size (Version)	Error correction level	Data capacity			Matrix size (Version)	Error correction level	Data capacity		
		Num. Cap.	Alpha Num. Cap.	8-bit binary			Num. Cap.	Alpha Num. Cap.	8-bit binary
29 × 29 (Version 3)	L (7%)	127	77	53	41 × 41 (Version 6)	L (7%)	322	195	134
	M (15%)	101	61	42		M (15%)	255	154	106
	Q (25%)	77	47	32		Q (25%)	178	108	74
	H (30%)	58	35	24		H (30%)	139	84	58

## Data Matrix

### Data Matrix (ECC200)

The relation between matrix size (number of cells) and data capacity is shown in the table below.

In this example, the matrix size is 12 × 12 cells.

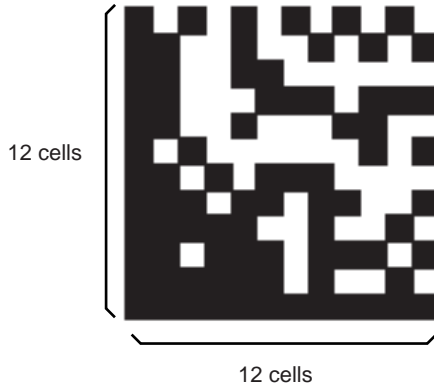

Matrix size	Maximum data capacity		
	Num. Cap.	Alpha Num. Cap.	Alpha Num. Symbols
10 × 10	6	3	3
12 × 12	10	6	5
14 × 14	16	10	9
16 × 16	24	16	14
18 × 18	36	25	22
20 × 20	44	31	28
22 × 22	60	43	38
24 × 24	72	52	46
26 × 26	88	64	57

# Appendix D

## Glossary

This glossary focuses on terms related to QR Codes and Data Matrix codes which are matrix-type 2-dimensional codes. There may be some parts of this glossary that do not apply to other types of 2-dimensional codes.

### Data Matrix

Data Matrix codes were developed by I.D. Matrix, and are used extensively in the semiconductor and electronics industries. Data Matrix codes have a relatively large data capacity for their size. There are several different types of Data Matrix, differentiated by their error correction method. The ECC200 is the most commonly used type.



### QR Code

The “Quick Response Code” type is a 2-dimensional code that was developed in Japan. High-speed reading is possible with QR Codes, but the code size is quite large compared to other 2-dimensional codes.



### Error Correction

This term is used to describe the function which detects and corrects errors using a special mathematical technique (commonly known as the “Reed-Solomon” method). Using this function, reading is possible, to a certain extent, for codes with poor printing quality or that are damaged. There are, however, limits on the extent to which correction is possible, and reading may not be possible for codes if the damage is extensive. There are 2-dimensional codes for which the error correction level can be selected. (For example, with QR Codes, error correction levels of 7%, 15%, 25%, or 30% are available.)

## Pixel

Pixels are the points that make up images. The monitor screen is 512 pixels high and 484 pixels wide which means that the screen contains approximately 250,000 pixels. Adjust the field of vision so that the number of pixels per cell is at least 5. The number of pixels per cell can be measured in **Image Analysis/Measure Length. page 89**

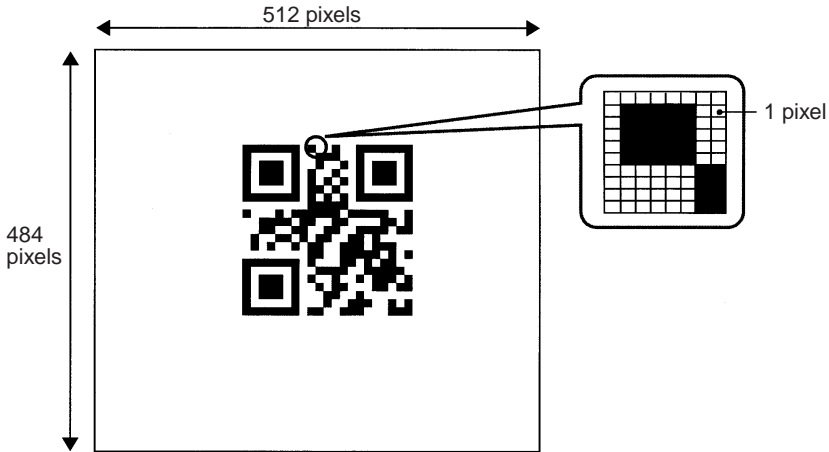

## Maximum Data Capacity

The maximum amount of data that can be stored in a code varies with the code size. In other words, if there is a large amount of data to be stored, then the code size must also be large. The maximum data capacity will also vary with the type of characters used. With QR Codes and Data Matrix codes, the numeric capacity (numbers only) is larger than the alpha numeric capacity (numbers and letters).

## Right and Left Reversal

This is the term used to describe reading 2-dimensional codes marked on a transparent material from the reverse side.

## Black and White Reversal

Usually, in images of 2-dimensional codes, the code itself is black and the background is white. Sometimes, however, due to the material of the reading object and the kind of lighting used, the code will appear white in the image obtained. This phenomenon is called "black and white reversal."

## Cell

These squares are the units that make up matrix-type 2-dimensional codes. Whether these cells are black or white determines the information carried by the code.

## Timing Pattern

These patterns are used to determine symbol density and horizontal and vertical dimensions and thereby obtain a frame of reference for 2-dimensional codes. The timing patterns are straight lines composed of alternating black and white cells.



## Version (QR Code)

The code size of QR Codes is indicated by the version. "Version 1" indicates that a QR Code contains (the minimum) 21 cells both horizontally and vertically. The larger the version number, the larger the number of cells per side.

## Pattern Search

This is a method for locating finder patterns. Images of finder patterns are registered as models in advance and searches are made for similar parts of input images. The degree of similarity is expressed as a correlation value (0 to 100). The more similar the pattern, the higher the correlation value. The place with the highest correlation value out of places with a correlation value over a set threshold value is deemed to be the finder pattern. If it is not possible to detect a finder pattern, decrease this threshold value. If too many finder patterns are detected, increase this threshold value.

## Finder Pattern

These are patterns used to detect the position of 2-dimensional codes. The shape of the finder patterns varies with the type of code.

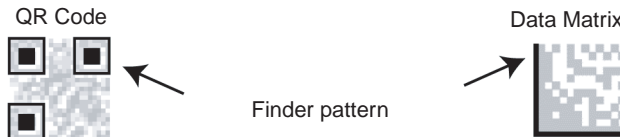

## Resolution

The resolution is a measure of the detail with which images are displayed. The V530-C300E can display images (via a monitor) using approximately 250,000 pixels (512 × 484). This means that if the field of vision is 512 mm × 484 mm, the resolution will be 1 (mm/pixel).

## Marking Methods

There are several marking methods that can be used. The most suitable method will depend on factors such as the material of the object onto which the code is marked. The most commonly used marking devices are listed below.

- Printer

A printer can be used to print codes onto paper and different kinds of labels.

- Laser Marker

A laser marker can be used to mark metal objects. A laser marker can mark very finely enabling the size of 2-dimensional codes can be reduced.

- Exposure Marking

Using exposure marking, particles are not created (unlike laser marking) and even finer marking is possible than with laser marking. Exposure marking is used with semiconductor wafers, LCD panels, and color filters that have exposure processing.

## Margin

This is the empty space around 2-dimensional codes. Usually it is necessary to ensure that there is a margin around 2-dimensional codes.



■ The black area is the margin.



# Index

## Numerics

2-dimensional code xv

## A

ambient humidity  
  inspection 150  
ambient temperature xii  
  inspection 150  
ASCII codes 175

## B

buzzer 109, 145

## C

cables 11, 24  
  precautions xiii  
  specifications 157  
  wiring examples 21, 23  
Camera  
  precautions xv  
cell position 106  
commands  
  input format 124  
  system data commands 136  
communications  
  errors 172  
  examples of settings 22, 23  
  Normal mode 22, 23  
  RS-232C 18, 107  
components  
  connections 10  
  dimensions 151  
  names and functions 8  
  specifications 151  
connections

  components 10  
  errors 171  
  examples 21  
  RS-232C 18  
  to personal computer 23  
connector 16  
Console 35  
  dimensions 158  
  keys 35  
  specifications 158  
Controller  
  mounting/removing 13  
copying  
  scene data 118  
crimp terminals  
  *See* terminals

## D

data  
  capacity 179  
  clearing scene data 119  
  copying scene data 118  
  loading 116  
  output format 19  
  saving 115  
Data Matrix codes  
  data capacity 180  
  error codes for 125  
  list 105  
  Normal mode  
    menu tree 49  
  Pattern mode  
    menu tree 50  
  reading 38  
    errors 168  
detail data 105  
dimensions 151

2-Dimensional Code Reader 152  
Console 158  
LCD Monitor 160  
V530-H301 Scanner 154  
V530-H302 Scanner 154  
V530-H303 Scanner 155  
Video Monitor 159  
DIN Track  
    mounting 13  
display 36

## E

errors  
    error codes 125, 166  
    troubleshooting 163

## F

FCS  
    calculation 20  
    program examples 177  
features 1  
finder pattern 106  
flash memory 120  
flat surface  
    mounting 14  
freeze images 103  
functions 8, 45

## I

images 103  
    adjusting 53  
    model registration 62, 78  
    reference models 66, 81  
    scenes 117  
    storing 110  
inputs  
    input specifications 25  
    input terminals 26

inspections 149  
installation 7  
    ambient temperature xii  
    inspection 150  
    noise resistance xiii  
    precautions xi, 150  
    Scanner xiv  
    Video Monitor xv

## K

keys  
    *See* Console keys

## L

LCD Monitor  
    dimensions 160  
    specifications 160  
loading 116

## M

maintenance 149  
memory  
    images 103  
menu  
    operations  
        errors 172  
        registration 46  
        tree 49  
modes  
    changing 48  
    overview 36  
    RUN mode 102  
    System mode 107  
    Tool mode 113

## N

noise resistance xiii  
nomenclature 8

**O**

- operations 45
  - changing modes 48
  - examples for personal computers 114
  - in SET mode 46
  - overview 4
  - using Console 35, 45
  - using DIP switch 31

**P**

- power supply
  - inspection 150
  - wiring 11, 12
- precautions
  - cables xiii
  - general x
  - installation xi
  - safety x
  - Video Monitor xv
- programming
  - examples 22, 24

**Q**

- QR codes
  - data capacity 179
  - error codes for 125
  - list 105
  - Normal mode
    - menu tree 51
  - Pattern mode
    - menu tree 52
  - reading 41
    - errors 166

**R**

- reading
  - codes 164
  - conditions 31, 37
  - data 104

- Data Matrix codes
  - in Normal mode 49
  - in Pattern mode 50
- performing 43
- QR codes
  - in Normal mode 51
  - in Pattern mode 52
- starting operation 34, 43
- reference models 66, 81

**RS/CS**

- connections 17

**RS-232C**

- communications 18, 107
  - errors 172
- specifications 16

**S**

- saving 115
  - to flash memory 120
- Scanner
  - installation xiv
- scene data
  - clearing 119
  - copying 118
  - See also* data
- scenes 117
- SET mode 46
- specifications 150, 151
  - 2-Dimensional Code Reader 152
  - cables 157
  - components 151
  - Console 158
  - LCD Monitor 160
  - power supply 12
  - RS-232C 16
  - Scanners 155
  - terminal blocks 24
  - Video Monitor 159
- startup 36
- storing 110

**T**

teaching 33, 70, 164  
terminal blocks 15  
    errors 172  
    specifications 24  
terminals 11, 24  
    input terminals 26  
through images 103  
timing 26  
troubleshooting 163

**V**

version information 112  
Video Monitor  
    dimensions 159  
    installation xv  
    specifications 159

**W**

wiring  
    Normal mode 21, 23  
    power supply 11, 12  
    RS-232C 17

# Revision History

A manual revision code appears as a suffix to the catalog number on the front cover of the manual.

Cat. No. Z150-E1-01

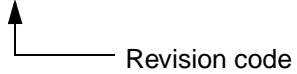

The following table outlines the changes made to the manual during each revision. Page numbers refer to the previous version.

Revision code	Date	Revised content
01	August 2001	Original production