

Σ -II Series SGM□H/SGDH

USER'S MANUAL

Design and Maintenance

SGMAH/SGMPH/SGMGH/SGMSH/SGMDH/SGMUH Servomotors
SGDH Servopack

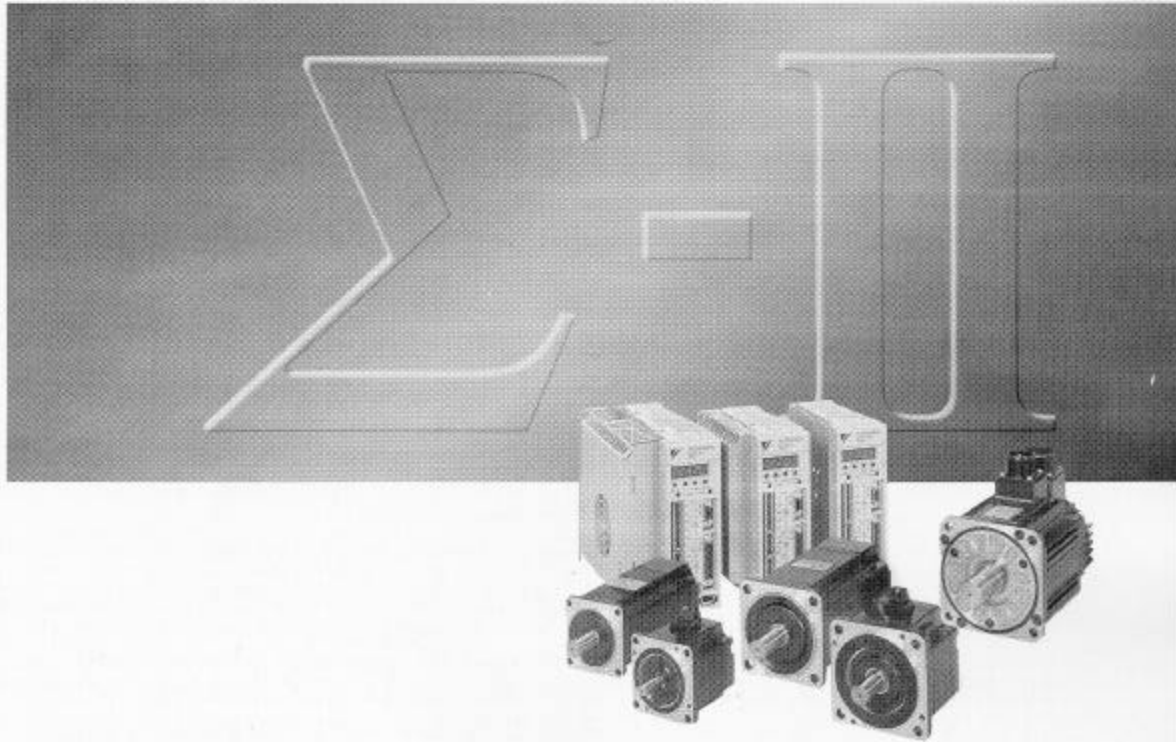

YASKAWA

MANUAL NO. SIE-S800-32.2C



Safety Information

The following conventions are used to indicate precautions in this manual. Failure to heed precautions provided in this manual can result in serious or possibly even fatal injury or damage to the products or to related equipment and systems.

 **WARNING** Indicates precautions that, if not heeded, could possibly result in loss of life or serious injury.

 **CAUTION** Indicates precautions that, if not heeded, could result in relatively serious or minor injury, damage to the product, or faulty operation.

 **PROHIBITED** Indicates actions that must never be taken.

©Yaskawa, 1999

All rights reserved. No part of this publication may be reproduced, stored in a retrieval system, or transmitted, in any form, or by any means, mechanical, electronic, photocopying, recording, or otherwise, without the prior written permission of Yaskawa. No patent liability is assumed with respect to the use of the information contained herein. Moreover, because Yaskawa is constantly striving to improve its high-quality products, the information contained in this manual is subject to change without notice. Every precaution has been taken in the preparation of this manual. Nevertheless, Yaskawa assumes no responsibility for errors or omissions. Neither is any liability assumed for damages resulting from the use of the information contained in this publication.

Visual Aids

The following aids are used to indicate certain types of information for easier reference.



Indicates application examples.



Indicates supplemental information.



Indicates important information that should be memorized, including precautions such as alarm displays to avoid damaging the devices.

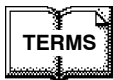

Indicates definitions of difficult terms or terms that have not been previously explained in this manual.

CONTENTS

Safety Information	iii
Visual Aids	iv
Overview	xi
Using This Manual	xii
Safety Precautions	xiii
SGDH Servopack Standards and Certification	xv
1 Checking Products and Part Names	
1.1 Checking Σ-II Series Products on Delivery	1 -2
1.1.1 Servomotors	1 -2
1.1.2 Servopacks	1 -6
1.2 Product Part Names	1 -8
1.2.1 Servomotors	1 -8
1.2.2 Servopacks	1 -9
2 Installation	
2.1 Servomotors	2 -2
2.1.1 Storage Temperature	2 -2
2.1.2 Installation Site	2 -3
2.1.3 Alignment	2 -3
2.1.4 Orientation	2 -3
2.1.5 Allowable Shaft Loads	2 -4
2.1.6 Handling Oil and Water	2 -6
2.1.7 Cable Stress	2 -6
2.2 Servopacks	2 -7
2.2.1 Storage Conditions	2 -7
2.2.2 Operating Conditions	2 -7
2.2.3 Installation Site	2 -8
2.2.4 Orientation	2 -8
2.2.5 Installation	2 -9
2.2.6 Voltage Resistance Test	2 -10
3 Wiring	
3.1 Connecting to Peripheral Devices	3 -3
3.1.1 Single-phase (100 V or 200 V) Main Circuit Specifications	3 -4
3.1.2 Three-phase (200 V) Main Circuit Specifications	3 -5
3.1.3 Three-phase (400 V) Main Circuit Specifications	3 -6
3.2 Servopack Internal Block Diagrams	3 -7
3.2.1 30 to 400 W 200-V and 30 to 200 W 100-V Models	3 -7
3.2.2 0.5 kW to 1.5 kW 200-V Models	3 -8
3.2.3 2.0 kW to 5.0 kW 200-V Models	3 -8
3.2.4 6.0 kW to 15.0 kW 200-V Models	3 -9
3.2.5 0.5 kW to 3.0 kW 400-V Models	3 -9

3.2.6	5.0 kW 400-V Models	3 -10
3.2.7	6.0 kW and 7.5 kW 400-V Models	3 -10
3.2.8	11.0 kW and 15.0 kW 400-V Models	3 -11
3.3	Main Circuit Wiring	3 -12
3.3.1	Names and Descriptions of Main Circuit Terminals	3 -13
3.3.2	Typical Main Circuit Wiring Example	3 -14
3.3.3	Cable Specifications and Peripheral Devices	3 -14
3.3.4	Servopack Power Losses	3 -15
3.3.5	Wiring Main Circuit Terminal Blocks	3 -16
3.4	I/O Signals	3 -18
3.4.1	Examples of I/O Signal Connections	3 -19
3.4.2	List of CN1 Terminals	3 -20
3.4.3	I/O Signal Names and Functions	3 -21
3.4.4	Interface Circuits	3 -24
3.5	Wiring Encoders	3 -27
3.5.1	Connecting an Encoder (CN2) and Output Signals from the Servopack (CN1) .	3 -27
3.5.2	CN2 Encoder Connector Terminal Layout and Types	3 -28
3.6	Examples of Standard Connections	3 -29
3.6.1	Single-phase Power Supply Specifications	3 -29
3.6.2	Three-phase Power Supply Specifications (200 V)	3 -31
3.6.3	Three-phase Power Supply Specifications (400 V)	3 -33
3.6.4	Position Control Mode	3 -35
3.6.5	Speed Control Mode	3 -37
3.6.6	Torque Control Mode	3 -39
4	Trial Operation	
4.1	Two-step Trial Operation	4 -2
4.1.1	Step 1: Trial Operation for Servomotor without Load	4 -3
4.1.2	Step 2: Trial Operation with the Servomotor Connected to the Machine	4 -9
4.2	Supplementary Information on Trial Operation	4 -10
4.2.1	Servomotors with Brakes	4 -10
4.2.2	Position Control by Host Controller	4 -11
4.3	Minimum User Constants and Input Signals	4 -12
4.3.1	User Constants	4 -12
4.3.2	Input Signals	4 -13
5	User Constant Settings and Functions	
5.1	Settings According to Device Characteristics	5 -4
5.1.1	Switching Servomotor Rotation Direction	5 -4
5.1.2	Setting the Overtravel Limit Function	5 -5
5.1.3	Limiting Torques	5 -9
5.2	Settings According to Host Controller	5 -13
5.2.1	Speed Reference	5 -13
5.2.2	Position Reference	5 -15

5.2.3 Using the Encoder Signal Output	5 -21
5.2.4 Sequence I/O Signals	5 -24
5.2.5 Using the Electronic Gear Function	5 -27
5.2.6 Contact Input Speed Control	5 -31
5.2.7 Using Torque Control	5 -36
5.2.8 Torque Feed-forward Function	5 -42
5.2.9 Speed Feed-forward Function	5 -43
5.2.10 Torque Limiting by Analog Voltage Reference, Function 1	5 -44
5.2.11 Torque Limiting by Analog Voltage Reference, Function 2	5 -45
5.2.12 Reference Pulse Inhibit Function (INHIBIT)	5 -47
5.3 Setting Up the Servopack	5 -48
5.3.1 User Constants	5 -48
5.3.2 JOG Speed	5 -49
5.3.3 Input Circuit Signal Allocation	5 -49
5.3.4 Output Circuit Signal Allocation	5 -55
5.3.5 Control Mode Selection	5 -58
5.4 Setting Stop Functions	5 -60
5.4.1 Adjusting Offset	5 -60
5.4.2 Using the Dynamic Brake	5 -61
5.4.3 Using the Zero Clamp Function	5 -62
5.4.4 Using the Holding Brake	5 -64
5.5 Forming a Protective Sequence	5 -68
5.5.1 Using Servo Alarm and Alarm Code Outputs	5 -68
5.5.2 Using the Servo ON Input Signal	5 -70
5.5.3 Using the Positioning Completed Output Signal	5 -71
5.5.4 Speed Coincidence Output	5 -72
5.5.5 Using the Running Output Signal	5 -74
5.5.6 Using the Servo Ready Output Signal	5 -75
5.5.7 Using the Warning Output Signal	5 -76
5.5.8 Using the Near Output Signal	5 -77
5.5.9 Handling Power Loss	5 -79
5.6 Selecting a Regenerative Resistor	5 -80
5.6.1 External Regenerative Resistors	5 -81
5.6.2 Calculating the Required Capacity of Regenerative Resistors	5 -84
5.7 Absolute Encoders	5 -92
5.7.1 Interface Circuit	5 -93
5.7.2 Selecting an Absolute Encoder	5 -94
5.7.3 Handling Batteries	5 -94
5.7.4 Absolute Encoder Setup	5 -95
5.7.5 Absolute Encoder Reception Sequence	5 -97
5.7.6 Multiturn Limit Setting	5 -101

5.8 Special Wiring	5 -105
5.8.1 Wiring Precautions	5 -105
5.8.2 Wiring for Noise Control	5 -109
5.8.3 Using More Than One Servodrive	5 -113
5.8.4 Extending Encoder Cables	5 -114
5.8.5 400-V Power Supply Voltage	5 -116
5.8.6 DC Reactor for Harmonic Suppression	5 -117
6 Servo Adjustment	
6.1 Smooth Operation	6 -2
6.1.1 Using the Soft Start Function	6 -2
6.1.2 Smoothing	6 -3
6.1.3 Adjusting Gain	6 -4
6.1.4 Adjusting Offset	6 -4
6.1.5 Setting the Torque Reference Filter Time Constant	6 -5
6.1.6 Notch Filter	6 -5
6.2 High-speed Positioning	6 -6
6.2.1 Setting Servo Gain	6 -6
6.2.2 Using Feed-forward Control	6 -8
6.2.3 Using Proportional Control	6 -8
6.2.4 Setting Speed Bias	6 -9
6.2.5 Using Mode Switch	6 -10
6.2.6 Speed Feedback Compensation	6 -13
6.3 Autotuning	6 -16
6.3.1 Online Autotuning	6 -16
6.3.2 Machine Rigidity Settings for Online Autotuning	6 -19
6.3.3 Saving Results of Online Autotuning	6 -21
6.3.4 User Constants Related to Online Autotuning	6 -23
6.4 Servo Gain Adjustments	6 -25
6.4.1 Servo Gain User Constants	6 -25
6.4.2 Basic Rules of Gain Adjustment	6 -25
6.4.3 Making Manual Adjustments	6 -27
6.4.4 Gain Setting Reference Values	6 -31
6.5 Analog Monitor	6 -33
7 Using the Digital Operator	
7.1 Basic Operation	7 -2
7.1.1 Connecting the Digital Operator	7 -2
7.1.2 Functions	7 -3
7.1.3 Resetting Servo Alarms	7 -4
7.1.4 Basic Mode Selection	7 -5
7.1.5 Status Display Mode	7 -5
7.1.6 Operation in User Constant Setting Mode	7 -8
7.1.7 Operation in Monitor Mode	7 -14
7.2 Applied Operation	7 -19
7.2.1 Operation in Alarm Traceback Mode	7 -20

7.2.2 Controlling Operation Through the Digital Operator	7 -22
7.2.3 Automatic Adjustment of the Speed and Torque Reference Offset	7 -24
7.2.4 Manual Adjustment of the Speed and Torque Reference Offset	7 -27
7.2.5 Clearing Alarm Traceback Data	7 -31
7.2.6 Checking the Motor Model	7 -33
7.2.7 Checking the Software Version	7 -36
7.2.8 Origin Search Mode	7 -37
7.2.9 Initializing User Constant Settings	7 -39
7.2.10 Manual Zero Adjustment and Gain Adjustment of Analog Monitor Output	7 -41
7.2.11 Adjusting the Motor Current Detection Offset	7 -46
7.2.12 Password Setting (Write Prohibited Setting)	7 -50
7.2.13 Clearing Option Unit Detection Results	7 -52

8 Ratings and Characteristics

8.1 Servomotors	8 -2
8.1.1 Ratings, Specifications, and Dimensional Drawings	8 -2
8.2 Servopacks	8 -28
8.2.1 Combined Specifications	8 -28
8.2.2 Ratings and Specifications	8 -33
8.2.3 Dimensional Drawings	8 -40

9 Inspection, Maintenance, and Troubleshooting

9.1 Servodrive Inspection and Maintenance	9 -2
9.1.1 Servomotor Inspection	9 -2
9.1.2 Servopack Inspection	9 -3
9.1.3 Replacing Battery for Absolute Encoder	9 -4
9.2 Troubleshooting	9 -5
9.2.1 Troubleshooting Problems with Alarm Displays	9 -5
9.2.2 Troubleshooting Problems with No Alarm Display	9 -32
9.2.3 Alarm Display Table	9 -34
9.2.4 Warning Displays	9 -36

A Host Controller Connection Examples

A.1 Connecting the GL-series MC20 Motion Module	A -2
A.2 Connecting the CP-9200SH Servo Controller Module (SVA) ..	A -3
A.3 Connecting the GL-series B2813 Positioning Module	A -4
A.4 Connecting OMRON's C500-NC221 Position Control Unit	A -5
A.5 Connecting OMRON's C500-NC112 Position Control Unit	A -6
A.6 Connecting MITSUBISHI's AD72 Positioning Unit	A -7
A.7 Connecting MITSUBISHI's AD75 Positioning Unit	A -8

B List of User Constants

B.1 User Constants	B -2
B.2 Switches	B -6
B.3 Input Signal Selections	B -11
B.4 Output Signal Selections	B -13
B.5 Auxiliary Functions	B -15
B.6 Monitor Modes	B -16

INDEX	Index-1
--------------------	----------------

Overview

■ About this Manual

This manual provides the following information for the Σ -II Series SGM□H/SGDH Servodrives.

- Procedures for installing and wiring the Servomotor and Servopack.
- Procedures for trial operation of the Servodrive.
- Procedures for using functions and adjusting the Servodrives.
- Procedures for using the built-in Panel Operator and the Hand-held Digital Operator.
- Ratings and specifications for standard models.
- Procedures for maintenance and inspection.

■ Related Manuals

Refer to the following manuals as required.

Read this manual carefully to ensure the proper use of Σ -II Series Servodrives. Also, keep this manual in a safe place so that it can be referred to whenever necessary.

Manual Name	Manual Number	Contents
Σ -II Series SGM□H/SGDH User's Manual Servo Selection and Data Sheets	SIE-S800-32.1	Describes the procedure used to select Σ -II Series Servodrives and capacities.
Σ -II Series Servopack Personal Computer Monitoring Software Operation Manual	SIE-S800-35	Describes the applications and operation of software for the Σ -II Series Servodrive monitoring devices for use on personal computers.
Σ -II Series SGM□H/SGDM Digital Operator Operation Manual	TOE-S800-34	Provides detailed information on the operation of the JUSP-OP02A-2 Digital Operator, which is an optional product.

Using This Manual

■ Intended Audience

This manual is intended for the following users.

- Those designing Σ -II Series Servodrive systems.
- Those installing or wiring Σ -II Series Servodrives.
- Those performing trial operation or adjustments of Σ -II Series Servodrives.
- Those maintaining or inspecting Σ -II Series Servodrives.

■ Description of Technical Terms

In this manual, the following terms are defined as follows:

- **Servomotor** = Σ -II Series SGMAH, SGMPH, SGMGH, SGMSH, SGMDH, or SGMUH Servomotor.
- **Servopack** = Σ -II Series SGDH Servopack.
- **Servodrive** = A set including a Servomotor and Servo Amplifier.
- **Servo System** = A servo control system that includes the combination of a Servodrive with a host computer and peripheral devices.

■ Indication of Reverse Signals

In this manual, the names of reverse signals (ones that are valid when low) are written with a forward slash (/) before the signal name, as shown in the following examples:

- /S-ON
- /P-CON

Safety Precautions

The following precautions are for checking products upon delivery, installation, wiring, operation, maintenance and inspections.

■ Checking Products upon Delivery

CAUTION

- Always use the Servomotor and Servopack in one of the specified combinations.
Not doing so may cause fire or malfunction.

■ Installation

CAUTION

- Never use the products in an environment subject to water, corrosive gases, inflammable gases, or combustibles
Doing so may result in electric shock or fire.

■ Wiring

WARNING

- Connect the ground terminal to electrical codes (ground resistance: 100 Ω or less).
Improper grounding may result in electric shock or fire.

CAUTION

- Do not connect a three-phase power supply to the U, V, or W output terminals.
Doing so may result in injury or fire.
- Securely fasten the power supply terminal screws and motor output terminal screws.
Not doing so may result in fire.

■ Operation

WARNING

- Never touch any rotating motor parts while the motor is running.
Doing so may result in injury.

CAUTION

- Conduct trial operation on the Servomotor alone with the motor shaft disconnected from machine to avoid any unexpected accidents.
Not doing so may result in injury.
- Before starting operation with a machine connected, change the settings to match the user's constants of the machine.
Starting operation without matching the proper settings may cause the machine to run out of control or malfunction.
- Before starting operation with a machine connected, make sure that an emergency stop can be applied at any time.
Not doing so may result in injury.
- Do not touch the heat sinks during operation.
Doing so may result in burns due to high temperatures.

■ Maintenance and Inspection

WARNING

- Never touch the inside of the Servopacks.
Doing so may result in electric shock.
- Do not remove the panel cover while the power is ON.
Doing so may result in electric shock.
- Do not touch terminals for five minutes after the power is turned OFF.
Residual voltage may cause electric shock.

CAUTION

- Do not disassemble the Servomotor.
Doing so may result in electric shock or injury.
- Do not attempt to change wiring while the power is ON.
Doing so may result in electric shock or injury.

■ General Precautions

Note the following to ensure safe application.

- The drawings presented in this manual are sometimes shown without covers or protective guards. Always replace the cover or protective guard as specified first, and then operate the products in accordance with the manual.
- The drawings presented in this manual are typical examples and may not match the product you received.
- This manual is subject to change due to product improvement, specification modification, and manual improvement. When this manual is revised, the manual code is updated and the new manual is published as a next edition. The edition number appears on the front and back covers.
- If the manual must be ordered due to loss or damage, inform your nearest Yaskawa representative or one of the offices listed on the back of this manual.
- Yaskawa will not take responsibility for the results of unauthorized modifications of this product. Yaskawa shall not be liable for any damages or troubles resulting from unauthorized modification.

SGDH Servopack Standards and Certification

SGDH Servopacks conform to the following standards.

- EN55011 group 1 class A
- EN50082-2

However, because this product is a built-in type, reconfirmation is required after being installed in the final product.



1

Checking Products and Part Names

This chapter describes the procedure for checking products upon delivery as well as names for product parts.

1.1	Checking Σ-II Series Products on Delivery	1 - 2
1.1.1	Servomotors	1 - 2
1.1.2	Servopacks	1 - 6
1.2	Product Part Names	1 - 8
1.2.1	Servomotors	1 - 8
1.2.2	Servopacks	1 - 9

1.1 Checking Σ -II Series Products on Delivery

The following procedure is used to check Σ -II Series products upon delivery. Check the following items when Σ -II Series products are delivered.

Check Items	Comments
Are the delivered products the ones that were ordered?	Check the model numbers marked on the nameplates of the Servomotor and Servopack. (Refer to the descriptions of model numbers on following pages)
Does the Servomotor shaft rotate smoothly?	The Servomotor shaft is normal if it can be turned smoothly by hand. Servomotors with brakes, however, cannot be turned manually.
Is there any damage?	Check the overall appearance, and check for damage or scratches that may have occurred during shipping.
Are there any loose screws?	Check screws for looseness using a screwdriver.

If any of the above items are faulty or incorrect, contact your Yaskawa sales representative or the dealer from whom you purchased the products.

1.1.1 Servomotors

External Appearance and Nameplate Examples

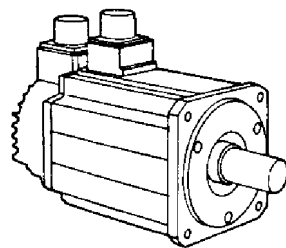

Σ -II Series Servomotor

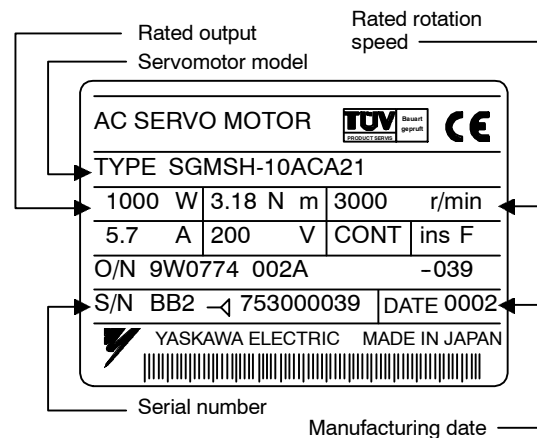

■ Model Numbers

Standard Servomotors

SGMPH - 01 A A A 2 S

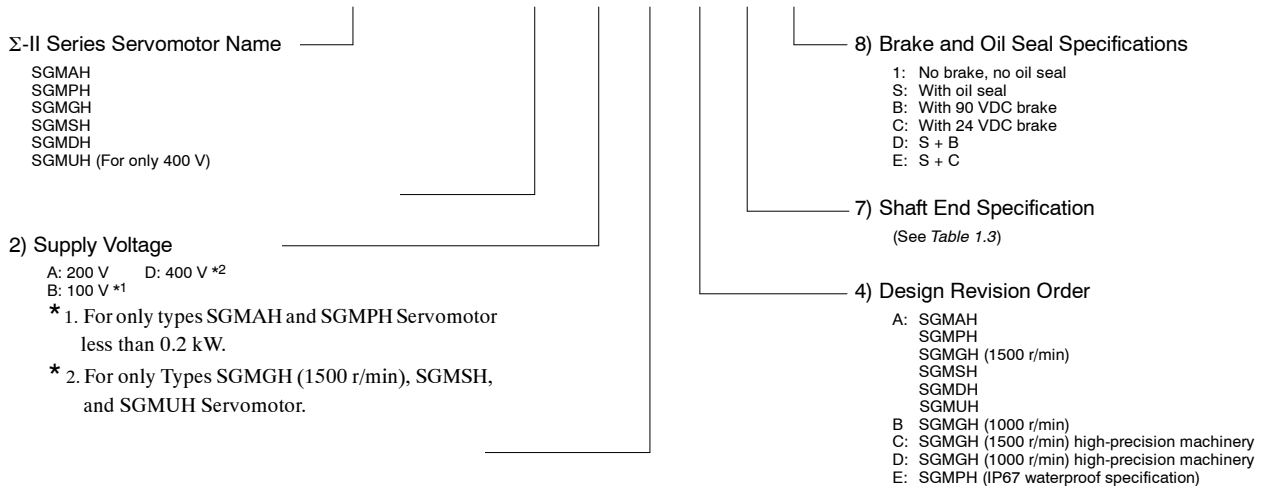

Table 1.1 Servomotor Capacity (kW)

Symbol	SGMAH	SGMPH	SGMGH		SGMSH	SGMDH	SGMUH	Symbol	SGMAH	SGMPH	SGMGH		SGMSH	SGMDH	SGMUH
	3000 r/min	3000 r/min	1500 r/min	1000 r/min	3000 r/min	2000 r/min	6000 r/min		3000 r/min	3000 r/min	1500 r/min	1000 r/min	3000 r/min	2000 r/min	6000 r/min
A3	0.03	-	-	-	-	-	-	15	-	1.5	-	-	1.5	-	1.5
A5	0.05	-	-	-	-	-	-	20	-	-	1.8	2.0	2.0	-	-
01	0.1	0.1	-	-	-	-	-	22	-	-	-	-	-	2.2	-
02	0.2	0.2	-	-	-	-	-	30	-	-	2.9	3.0	3.0	-	3.0
03	-	-	-	0.3	-	-	-	32	-	-	-	-	-	3.2	-
04	0.4	0.4	-	-	-	-	-	40	-	-	-	4.0	4.0	4.0	4.0
05	-	-	0.45	-	-	-	-	44	-	-	4.4	-	-	-	-
06	-	-	-	0.6	-	-	-	50	-	-	-	-	5.0	-	-
08	0.75	0.75	-	-	-	-	-	55	-	-	5.5	5.5	-	-	-
09	-	-	0.85	0.9	-	-	-	75	-	-	7.5	-	-	-	-
10	-	-	-	-	1.0	-	1.0	1A	-	-	11	-	-	-	-
12	-	-	-	1.2	-	-	-	1E	-	-	15	-	-	-	-
13	-	-	1.3	-	-	-	-								

Table 1.2 Serial Encoders

Code	Specification	SGMAH	SGMPH	SGMGH	SGMSH	SGMDH	SGMUH
1	16-bit absolute encoder	Standard	Standard	-	-	-	-
2	17-bit absolute encoder	-	-	Standard	Standard	Standard	-
A	13-bit incremental encoder	Standard	Standard	-	-	-	-
B	16-bit incremental encoder	Optional	Optional	-	-	-	-
C	17-bit incremental encoder	-	-	Standard	Standard	Standard	Standard

Table 1.3 Shaft End Specifications (Straight)

Code	Specification	SGMAH	SGMPH	SGMGH	SGMSH	SGMDH	SGMUH
2	Straight without key	Standard	Standard	Standard	Standard	Standard	Standard
3	Taper 1/10, with parallel key	-	-	Optional	Optional	-	Optional
4	Straight with key	Optional	Optional	-	-	-	-
5	Taper 1/10, with woodruff key	-	-	Optional*	-	-	-
6	Straight with key and tap	Optional	Optional	Optional	Optional	Optional	Optional
8	Straight with tap	Optional	Optional	-	-	-	-

* Varies with the motor capacity.

Servomotors with Gears

SGMPH - 01 A A A G 1 2 B

Σ-II Series Servomotor Name

- SGMAH
- SGMPH
- SGMGH
- SGMSH

8) Brake Specifications

- 1: Without brake
- B: With 90 VDC brake
- C: With 24 VDC brake

7) Shaft End Specifications

(See Table 1.8.)

6) Gear Ratio (See Table 1.7.)

(Varies with gear type.)

5) Gear Type (See Table 1.6.)

* For only types SGMAH and SGMPH Servomotor less than 0.2 kW.

3) Serial Encoder Specifications (See Table 1.5.)

4) Design Revision Order

- A: SGMAH
- SGMPH
- SGMGH (1500 r/min)
- SGMSH
- B: SGMGH (1000 r/min)
- E: SGMPH (IP67 waterproof specification)

Table 1.4 Servomotor Capacity (kW)

Symbol	SGMAH	SGMPH	SGMGH		SGMSH	Symbol	SGMAH	SGMPH	SGMGH		SGMSH
	3000 r/min	3000 r/min	1500 r/min	1000 r/min	3000 r/min		3000 r/min	3000 r/min	1500 r/min	1000 r/min	3000 r/min
A3	0.03	-	-	-	-	15	-	1.5	-	-	1.5
A5	0.05	-	-	-	-	20	-	-	1.8	2.0	2.0
01	0.1	0.1	-	-	-	22	-	-	-	-	-
02	0.2	0.2	-	-	-	30	-	-	2.9	3.0	3.0
03	-	-	-	0.3	-	32	-	-	-	-	-
04	0.4	0.4	-	-	-	40	-	-	-	4.0	4.0
05	-	-	0.45	-	-	44	-	-	4.4	-	-
06	-	-	-	0.6	-	50	-	-	-	-	5.0
08	0.75	0.75	-	-	-	55	-	-	5.5	5.5	-
09	-	-	0.85	0.9	-	75	-	-	7.5	-	-
10	-	-	-	-	1.0						
12	-	-	-	1.2	-						
13	-	-	1.3	-	-						

Table 1.5 Serial Encoders

Code	Specification	SGMAH	SGMPH	SGMGH	SGMSH
1	16-bit absolute encoder	Standard	Standard	-	-
2	17-bit absolute encoder	-	-	Standard	Standard
A	13-bit incremental encoder	Standard	Standard	-	-
B	16-bit incremental encoder	Optional	Optional	-	-
C	17-bit incremental encoder	-	-	Standard	Standard

Table 1.6 Gear Type

Code	Specification	SGMAH	SGMPH	SGMGH	SGMSH
G	HDS planetary low-backlash gear	Standard	Standard		
J	Standard backlash gear	Standard	Standard		
S	With foot			Standard	
T	Flange mounted			Standard	
L	IMT planetary low-backlash gear			Standard	Standard

Table 1.7 Gear Ratio (Varies with Gear Type.)

Code	Specification	SGMAH	SGMPH	SGMGH	SGMSH
A	1/6			S, T*	
B	1/11 or 1/11.13	G	G	S, T	
C	1/21	G, J	G, J	S, T	
1	1/5	G, J	G, J	L	L
2	1/9	G		L	L
3	1/10 or 1/10.3	J	J		
5	1/20			L*	L
7	1/29 or 1/33	G, J	G, J	L, S, T*	L*
8	1/45			L*	L*

* Not all applicable models available.

Table 1.8 Shaft End Specification (Varies with Gear Type.)

Code	Specification	SGMAH	SGMPH	SGMGH	SGMSH
0	No shaft	G	G		
2	Straight, without key	G, J	G, J		
4	Straight, with key	G	G	L	L
6	Straight, with key and tap	G, J	G, J	S, T	
8	Straight, with tap	G	G		

1.1.2 Servopacks

External Appearance and Nameplate Examples

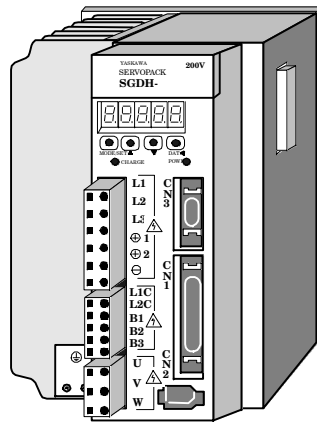

Σ-II Series SGDH Servopack

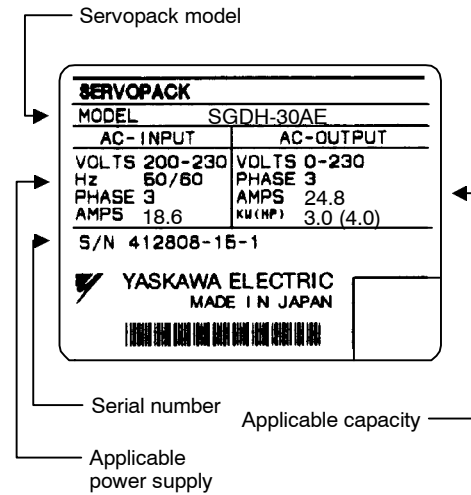

Model Numbers

SGDH - 10 A E - □

Σ-II Series
SGDH Servopack

Maximum Applicable Servomotor Capacity
(See Table 1.9.)

* 1. The only types SGMAH and SGMPPH Servomotor less than 0.2 kW.

* 2. For only 0.5 to 15 kW Servomotor.

Type

E: For torque, speed, and position control (for opinion unit)

Table 1.9

Maximum Applicable Servomotor Capacity Symbol	Capacity (kW)	Maximum Applicable Servomotor Capacity Symbol	Capacity (kW)
A3	0.03	15	1.5
A5	0.05	20	2.0
01	0.10	30	3.0
02	0.20	50	5.0
04	0.40	60	6.0
05	0.45	75	7.5
08	0.75	1A	11
10	1.0	1E	15

1.2 Product Part Names

This section describes product part names.

1.2.1 Servomotors

The figure below shows part names for Servomotors with or without brakes.

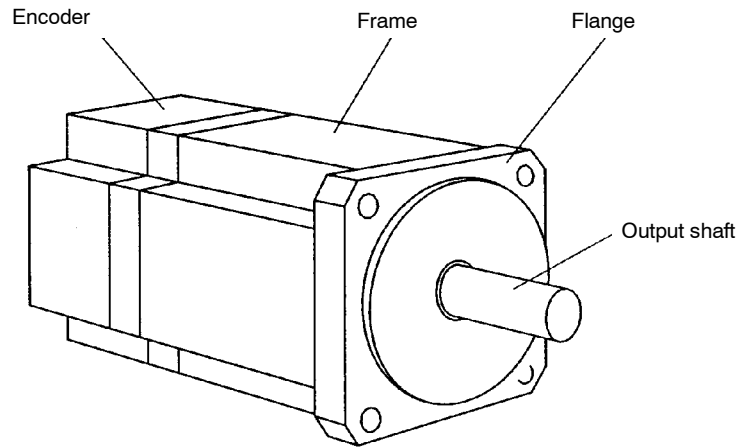

1

1.2.2 Servopacks

The figure below shows the part names for Servopacks.

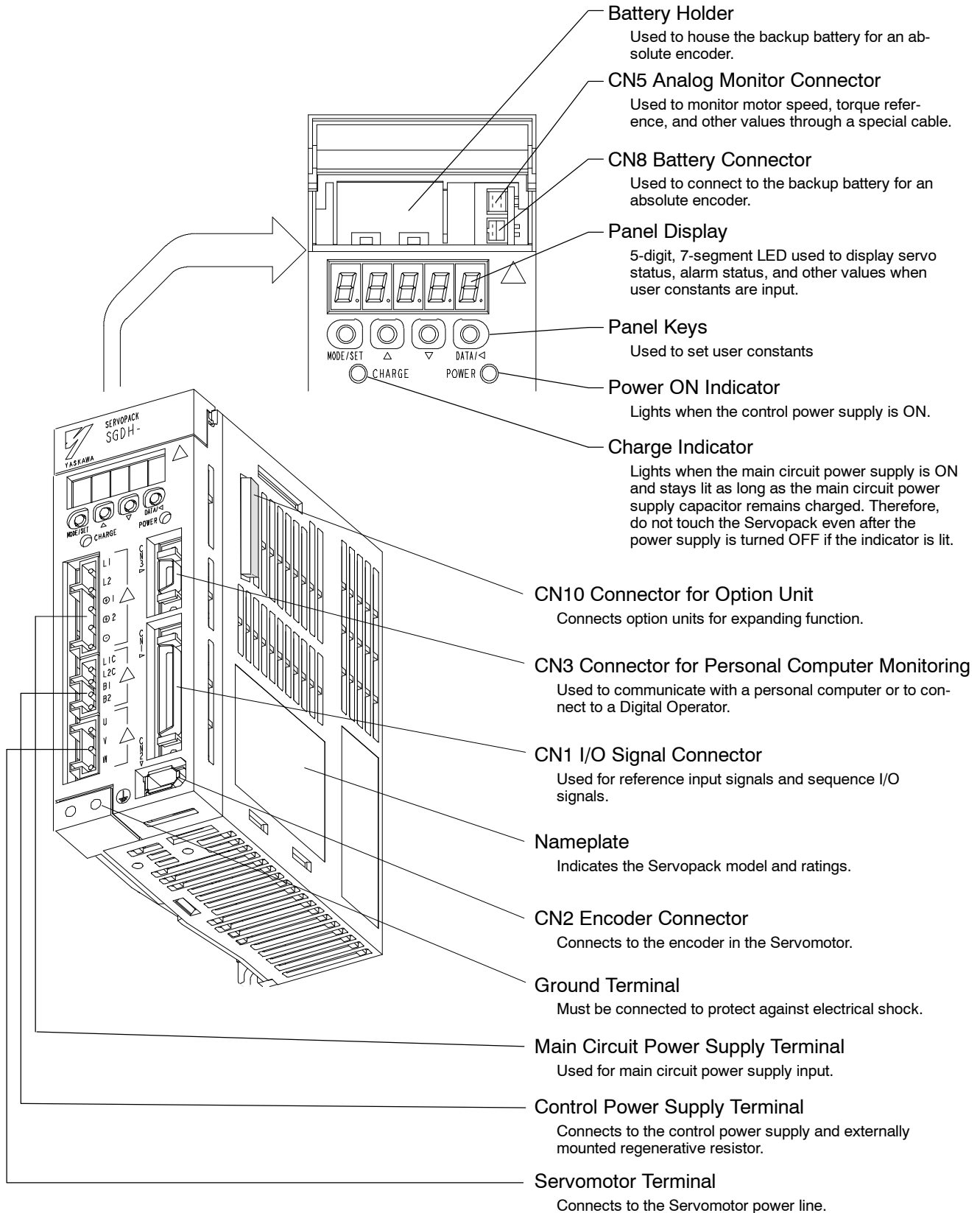

2

Installation

This chapter describes precautions for Σ -II Series Servomotor and Servopack installation.

2.1 Servomotors	2 -2
2.1.1 Storage Temperature	2 -2
2.1.2 Installation Site	2 -3
2.1.3 Alignment	2 -3
2.1.4 Orientation	2 -3
2.1.5 Allowable Shaft Loads	2 -4
2.1.6 Handling Oil and Water	2 -6
2.1.7 Cable Stress	2 -6
2.2 Servopacks	2 -7
2.2.1 Storage Conditions	2 -7
2.2.2 Operating Conditions	2 -7
2.2.3 Installation Site	2 -8
2.2.4 Orientation	2 -8
2.2.5 Installation	2 -9
2.2.6 Voltage Resistance Test	2 -10

2.1 Servomotors

SGM□H Servomotors can be installed either horizontally or vertically.

The service life of the Servomotor will be shortened or unexpected problems will occur if the Servomotor is installed incorrectly or in an inappropriate location. Always observe the following installation instructions.

! CAUTION

- Do not connect the Servomotor directly to a commercial power line. This will damage the Servomotor. The Servomotor cannot operate without the proper Servopack.

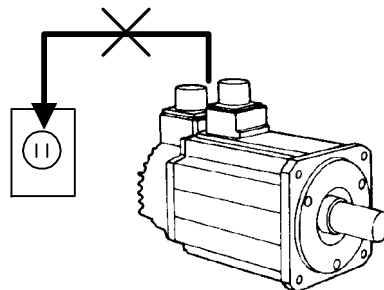

IMPORTANT

Prior to Installation

The end of the motor shaft is coated with anticorrosive paint. Thoroughly remove the paint using a cloth moistened with thinner prior to installation.

Avoid getting thinner on other parts of the Servomotor when cleaning the shaft.

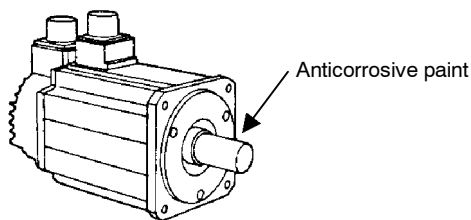

2.1.1 Storage Temperature

Store the Servomotor within the following temperature range if it is stored with the power cable disconnected.

-20 to 60°C

2.1.2 Installation Site

SGM□H Servomotors are designed for indoor use. Install the Servomotor in environments that satisfy the following conditions.

- Free of corrosive or explosive gases.
- Well-ventilated and free of dust and moisture.
- Ambient temperature of 0 to 40°C.
- Relative humidity of 20 to 80% with no condensation.
- Facilitates inspection and cleaning.

2.1.3 Alignment

Align the shaft of the Servomotor with the shaft of the equipment, and then couple the shafts. Install the Servomotor so that alignment accuracy falls within the following range.

Measure this distance at four different positions on the circumference. The difference between the maximum and minimum measurements must be 0.03 mm (0.0012 in) or less. (Turn together with coupling.)

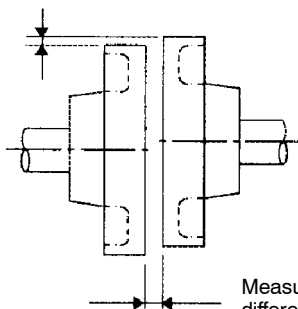

Measure this distance at four different positions on the circumference. The difference between the maximum and minimum measurements must be 0.03 mm (0.0012 in) or less. (Turn together with coupling.)

IMPORTANT

- Vibration that will damage the bearings will occur if the shafts are not properly aligned.
- Do not allow direct impact to be applied to the shafts when installing the coupling. Otherwise the encoder mounted on the opposite end of the shaft may be damaged.

2.1.4 Orientation

SGM□H Servomotors can be installed either horizontally or vertically.

2.1.5 Allowable Shaft Loads

Design the mechanical system so thrust and radial loads applied to the Servomotor shaft end during operation falls within the ranges shown in the *Table 2.1*.

The allowable radial load in the table is the maximum load allowed on the end of the output shaft.

Table 2.1 Allowable Radial and Thrust Loads for the Servomotor

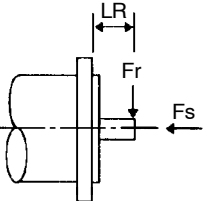
Servomotor Model	Allowable Radial Load * Fr [N (lbf)]	Allowable Thrust Load Fs [N (lbf)]	LR mm (inch)	Reference Diagram	
SGMAH- A3	68 (15.29)	54 (12.14)	20 (0.79)		
	A5	68 (15.29)			54 (12.14)
	01	78 (17.54)			54 (12.14)
	02	245 (55.1)	74 (16.63)		25 (0.98)
	04	245 (55.1)	74 (16.63)		35 (1.38)
	08	392 (88.1)	147 (33.0)		
SGMPH- 01	78 (17.54)	49 (11.02)	20 (0.79)		
	02	245 (55.1)	68 (15.29)		25 (0.98)
	04	245 (55.1)	68 (15.29)		35 (1.38)
	08	392 (88.1)	147 (33.0)		
	15	490 (110)	147 (33.0)		
SGMGH- 05A□A 05D A	490 (110)	98 (22.0)	58 (2.28)		
	09A□A 09D A	490 (110)		98 (22.0)	
	13A□A 13D A	686 (154)		343 (77.1)	
	20A□A 20D A	1176 (264.3)		490 (110)	79 (3.11)
	30A□A 30D A	1470 (330.4)	490 (110)	113 (4.45)	
	44A□A 44D□A	1470 (330.4)	490 (110)		
	55A□A 55D□A	1764 (396.5)	588 (132)	113 (4.45)	
	75A□A 75D□A	1764 (396.5)	588 (132)		
	1AA□A 1AD□A	1764 (396.5)	588 (132)	113 (4.45)	
	1EA□A 1ED□A	4998 (1123)	2156 (485)	116 ()	

Servomotor Model	Allowable Radial Load * Fr [N (lbf)]	Allowable Thrust Load Fs [N (lbf)]	LR mm (inch)	Reference Diagram
SGMGH-	03A□B	490 (110)	98 (22.0)	58 (2.28)
	06A□B	490 (110)	98 (22.0)	
	09A□B	686 (154)	343 (77.1)	
	12A□B	1176 (264.3)	490 (110)	79 (3.11)
	20A□B	1470 (330.4)	490 (110)	
	30A□B	1470 (330.4)	490 (110)	
	40A□B	1764 (396.5)	588 (132)	113 (4.45)
	55A□B	1764 (396.5)	588 (132)	
SGMSH-	10A, 10D	686 (154)	196 (44.1)	45 (1.77)
	15A, 15D	686 (154)	196 (44.1)	
	20A, 20D	686 (154)	196 (44.1)	
	30A, 30D	980 (220)	392 (88.1)	63 (2.48)
	40A, 40D	1176 (264.3)	392 (88.1)	
	50A, 50D	1176 (264.3)	392 (88.1)	
SGMDH-	22A	1176 (264.3)	490 (110)	55 (2.17)
	32A	1176 (264.3)	490 (110)	
	40A	1176 (264.3)	490 (110)	65 (2.56)
SGMUH-	10D	490 (110)	98 (22)	45 (1.77)
	15D	490 (110)	98 (22)	
	30D	686 (154)	196 (44.1)	60 (2.36)
	40D	686 (154)	196 (44.1)	

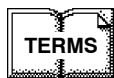
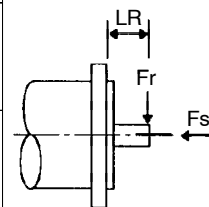

◆ Thrust and radial loads

Thrust load (Fs): Shaft-end load applied parallel to the centerline of the shaft.

Radial load (Fr): Shaft-end load applied perpendicular to the centerline of the shaft.

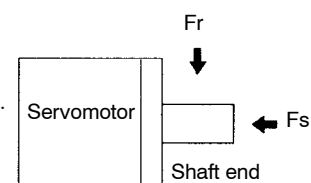

2.1.6 Handling Oil and Water

Install a protective cover over the Servomotor if it is used in a location that is subject to water or oil mist. Also use a Servomotor with an oil seal to seal the through shaft section.

Install the Servomotor with the connector facing down.

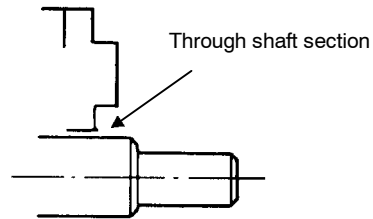

2.1.7 Cable Stress

Make sure there are no bends or tension on the power lines.

Be especially careful to wire signal line cables so that they are not subject to stress because the core wires are very thin at only 0.2 to 0.3 mm (0.0079 to 0.012 in).

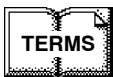

◆ Through sections of the shaft

This refers to the gap where the shaft protrudes from the end of the motor.

2.2 Servopacks

The SGDM Servopacks are base-mounted servoamps. Incorrect installation will cause problems. Always observe the installation instructions below.

2.2.1 Storage Conditions

Store the Servopack within the following temperature range if it is stored with the power cable disconnected.

-20 to 85°C

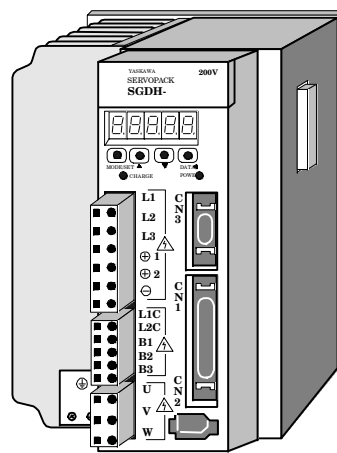

Σ-II Series SGDH Servopack

2.2.2 Operating Conditions

Use the Servopack under the following conditions.

- Installation category (Overvoltage category) * : II
- Pollution degree * : 2
- Protection class * : 1X
- Altitude : 1000 m max.

* Conforming to the following standards.
 EN55011 group 1 class A
 EN50082-2

2.2.3 Installation Site

Take the following precautions at the installation site.

Situation	Installation Precaution
Installation in a Control Panel	Design the control panel size, unit layout, and cooling method so the temperature around the Servopack does not exceed 55°C.
Installation Near a Heating Unit	Minimize heat radiated from the heating unit as well as any temperature rise caused by natural convection so the temperature around the Servopack does not exceed 55°C.
Installation Near a Source of Vibration	Install a vibration isolator beneath the Servopack to avoid subjecting it to vibration.
Installation at a Site Exposed to Corrosive Gas	Corrosive gas does not have an immediate effect on the Servopack, but will eventually cause electronic components and contactor-related devices to malfunction. Take appropriate action to avoid corrosive gas.
Other Situations	Do not install the Servopack in hot and humid locations or locations subject to excessive dust or iron powder in the air.

2.2.4 Orientation

Install the Servopack perpendicular to the wall as shown in the figure. The Servopack must be oriented this way because it is designed to be cooled by natural convection or cooling fan.

Secure the Servopack using 2 to 4 mounting holes. The number of holes depends on the capacity.

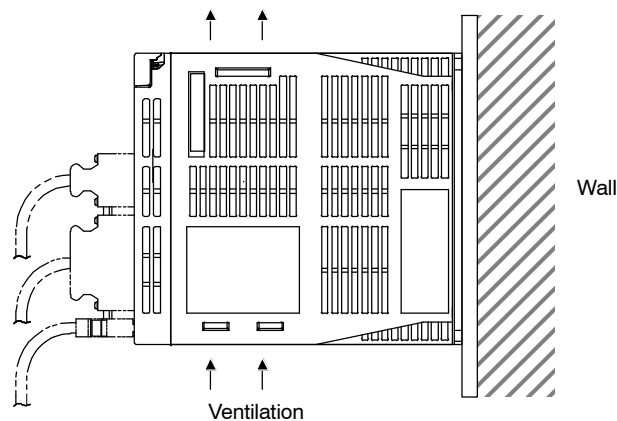

2.2.5 Installation

Follow the procedure below to install multiple Servopacks side by side in a control panel.

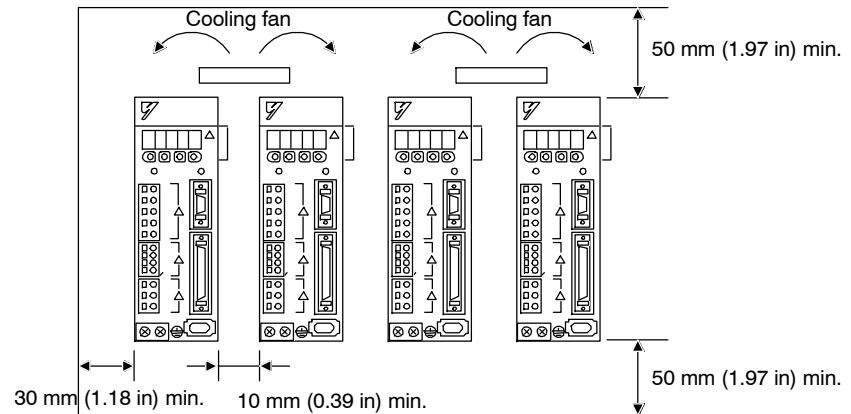

■ Servopack Orientation

Install the Servopack perpendicular to the wall so the front panel containing connectors faces outward.

■ Cooling

As shown in the figure above, allow sufficient space around each Servopack for cooling by cooling fans or natural convection.

■ Side-by-side Installation

When installing Servopacks side by side as shown in the figure above, allow at least 10 mm (0.39 in) between and at least 50 mm (1.97 in) above and below each Servopack. Install cooling fans above the Servopacks to avoid excessive temperature rise and to maintain even temperature inside the control panel.

■ Environmental Conditions in the Control Panel

- Ambient Temperature: 0 to 55°C
- Humidity: 90% RH or less
- Vibration: 0.5 G (4.9 m/s²)
- Condensation and Freezing: None
- Ambient Temperature for Long-term Reliability: 45°C max.

2.2.6 Voltage Resistance Test



WARNING

- After voltage resistance test, wait at least five minutes before servicing the product.
Failure to observe this warning may result in electric shock.

Conduct voltage resistance tests under the following conditions.

- Voltage: 1500 V rms AC. for one minute
- Braking current: 30 mA or more
- Frequency: 50 or 60 Hz
- Voltage applied points
 - For SGDH- AE Servopacks: Between the frame ground and the point where the terminals L1, L2, L3, L1C, L2C, U, V, and W connect.
 - For SGDH- DE Servopacks: Between the neutral ground terminal and the point where the terminals L1, L2, L3, U, V, and W connect.

3

Wiring

3

This chapter describes the procedure used to connect Σ -II Series products to peripheral devices and gives typical examples of main circuit wiring as well as I/O signal connections.

3.1	Connecting to Peripheral Devices	3 -3
3.1.1	Single-phase (100 V or 200 V) Main Circuit Specifications	3 -4
3.1.2	Three-phase (200 V) Main Circuit Specifications	3 -5
3.1.3	Three-phase (400 V) Main Circuit Specifications	3 -6
3.2	Servopack Internal Block Diagrams	3 -7
3.2.1	30 to 400 W 200-V and 30 to 200 W 100-V Models	3 -7
3.2.2	0.5 kW to 1.5 kW 200-V Models	3 -8
3.2.3	2.0 kW to 5.0 kW 200-V Models	3 -8
3.2.4	6.0 kW to 15.0 kW 200-V Models	3 -9
3.2.5	0.5 kW to 3.0 kW 400-V Models	3 -9
3.2.6	5.0 kW 400-V Models	3 -10
3.2.7	6.0 kW and 7.5 kW 400-V Models	3 -10
3.2.8	11.0 kW and 15.0 kW 400-V Models	3 -11
3.3	Main Circuit Wiring	3 -12
3.3.1	Names and Descriptions of Main Circuit Terminals	3 -13
3.3.2	Typical Main Circuit Wiring Example	3 -14
3.3.3	Cable Specifications and Peripheral Devices	3 -14
3.3.4	Servopack Power Losses	3 -15
3.3.5	Wiring Main Circuit Terminal Blocks	3 -16

3.4 I/O Signals	3 -18
3.4.1 Examples of I/O Signal Connections	3 -19
3.4.2 List of CN1 Terminals	3 -20
3.4.3 I/O Signal Names and Functions	3 -21
3.4.4 Interface Circuits	3 -24
3.5 Wiring Encoders	3 -27
3.5.1 Connecting an Encoder (CN2) and Output Signals from the Servopack (CN1)	3 -27
3.5.2 CN2 Encoder Connector Terminal Layout and Types	3 -28
3.6 Examples of Standard Connections	3 -29
3.6.1 Single-phase Power Supply Specifications	3 -29
3.6.2 Three-phase Power Supply Specifications (200 V)	3 -31
3.6.3 Three-phase Power Supply Specifications (400 V)	3 -33
3.6.4 Position Control Mode	3 -35
3.6.5 Speed Control Mode	3 -37
3.6.6 Torque Control Mode	3 -39

3.1 Connecting to Peripheral Devices

This section provides examples of standard Σ -II Series product connections to peripheral devices.

It also briefly explains how to connect each peripheral device.

3.1.1 Single-phase (100 V or 200 V) Main Circuit Specifications

3

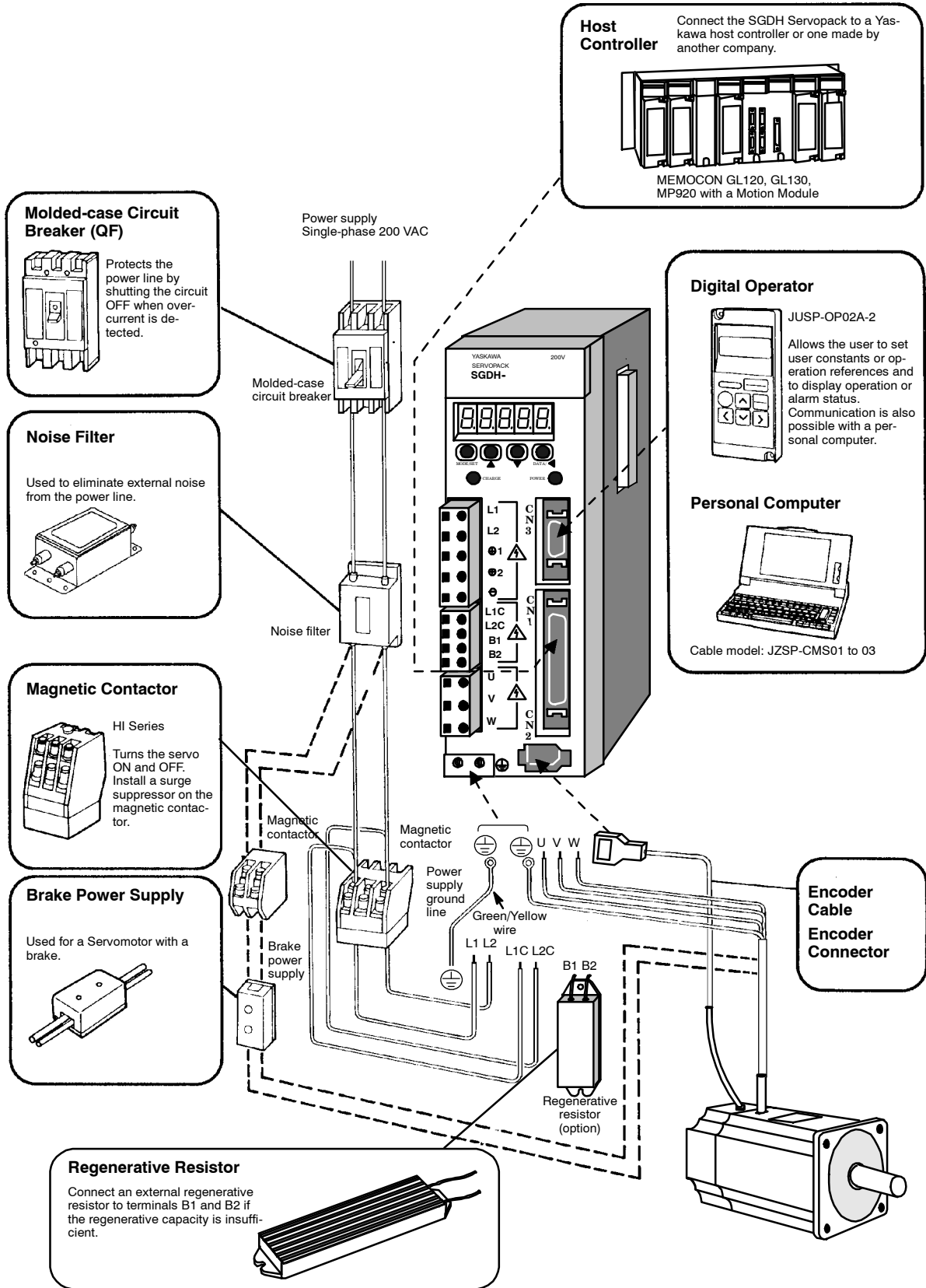

3.1.2 Three-phase (200 V) Main Circuit Specifications

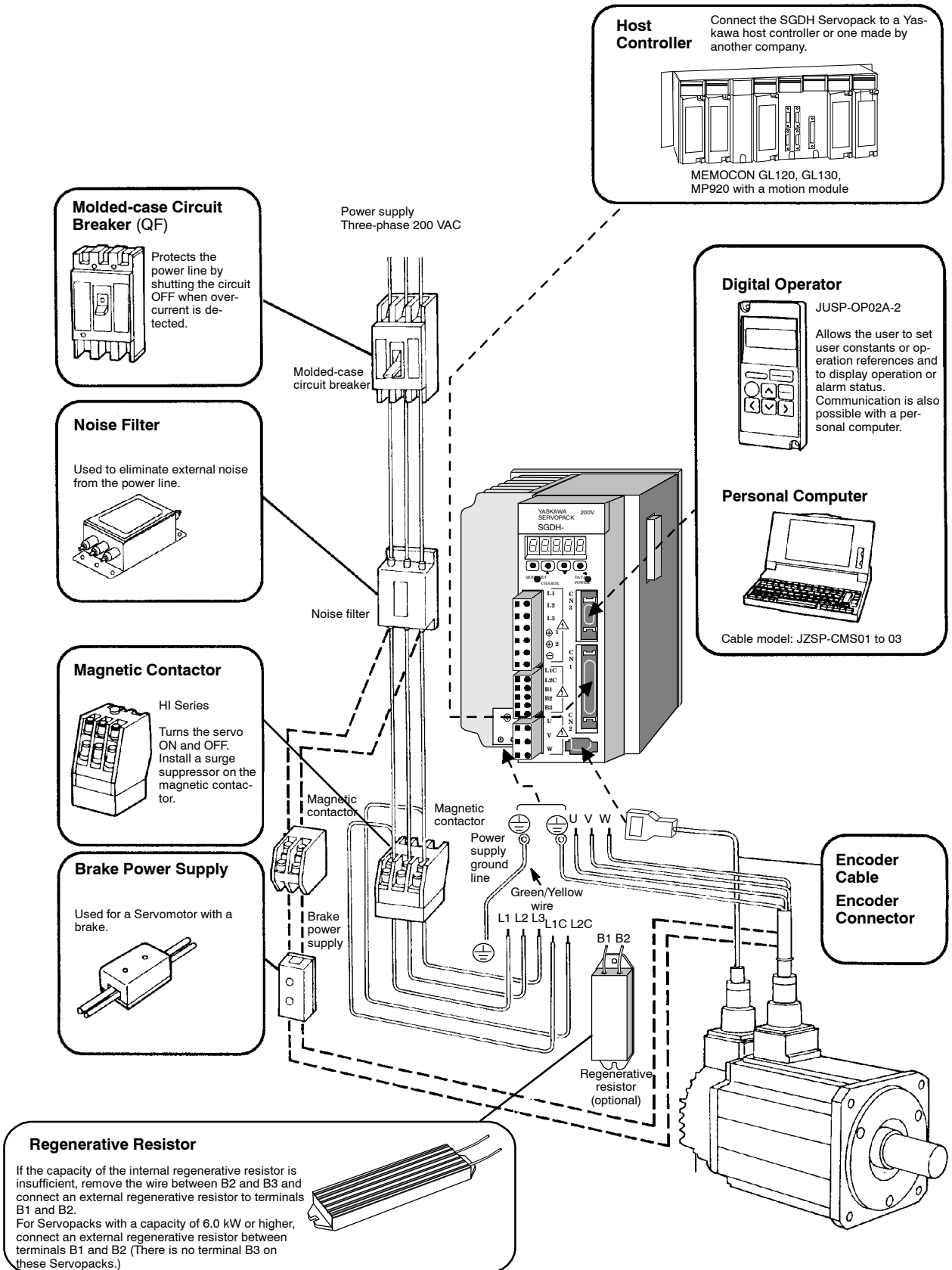

3.1.3 Three-phase (400 V) Main Circuit Specifications

3

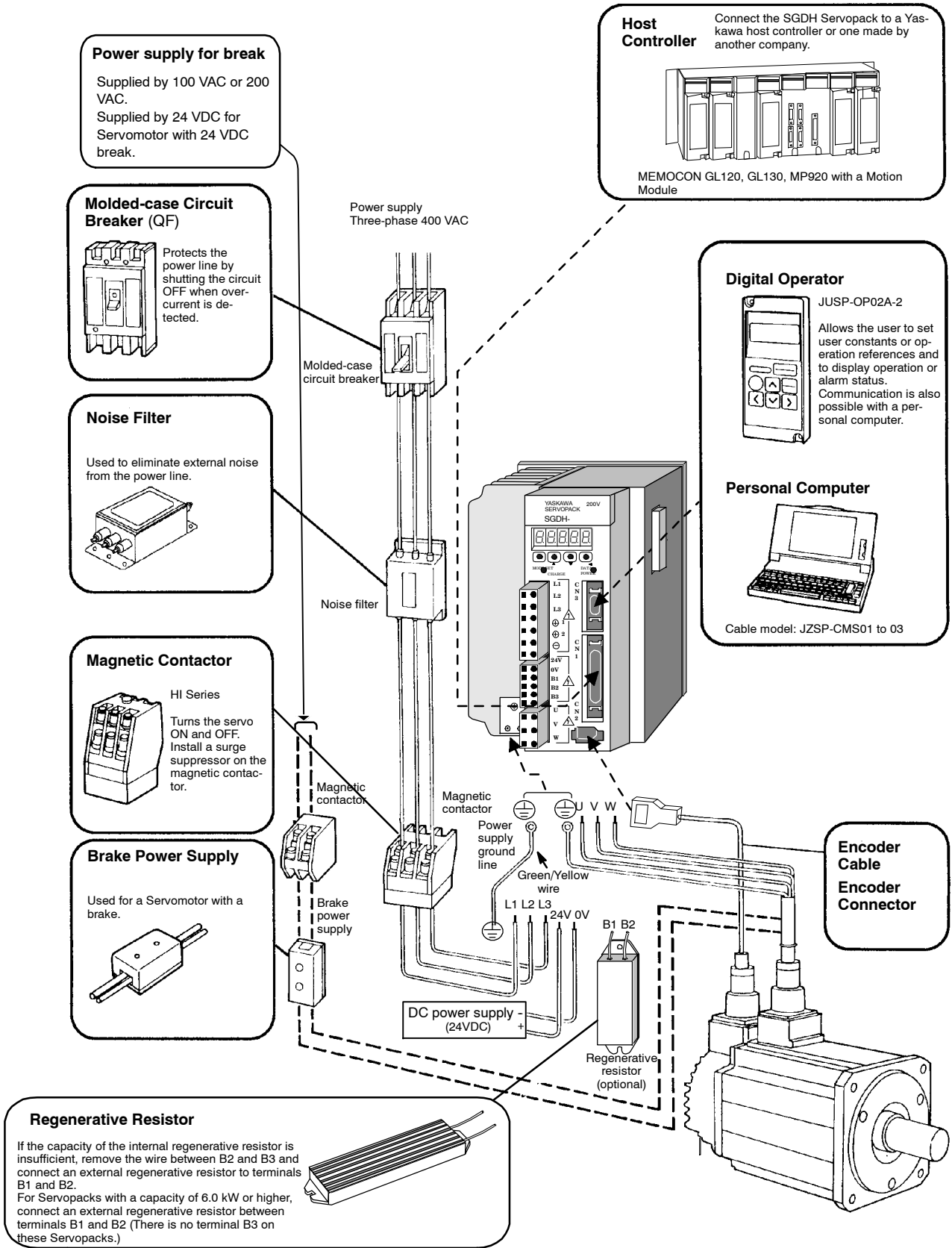

3.2 Servopack Internal Block Diagrams

The following sections show internal block diagrams of the Servopacks.

3.2.1 30 to 400 W 200-V and 30 to 200 W 100-V Models

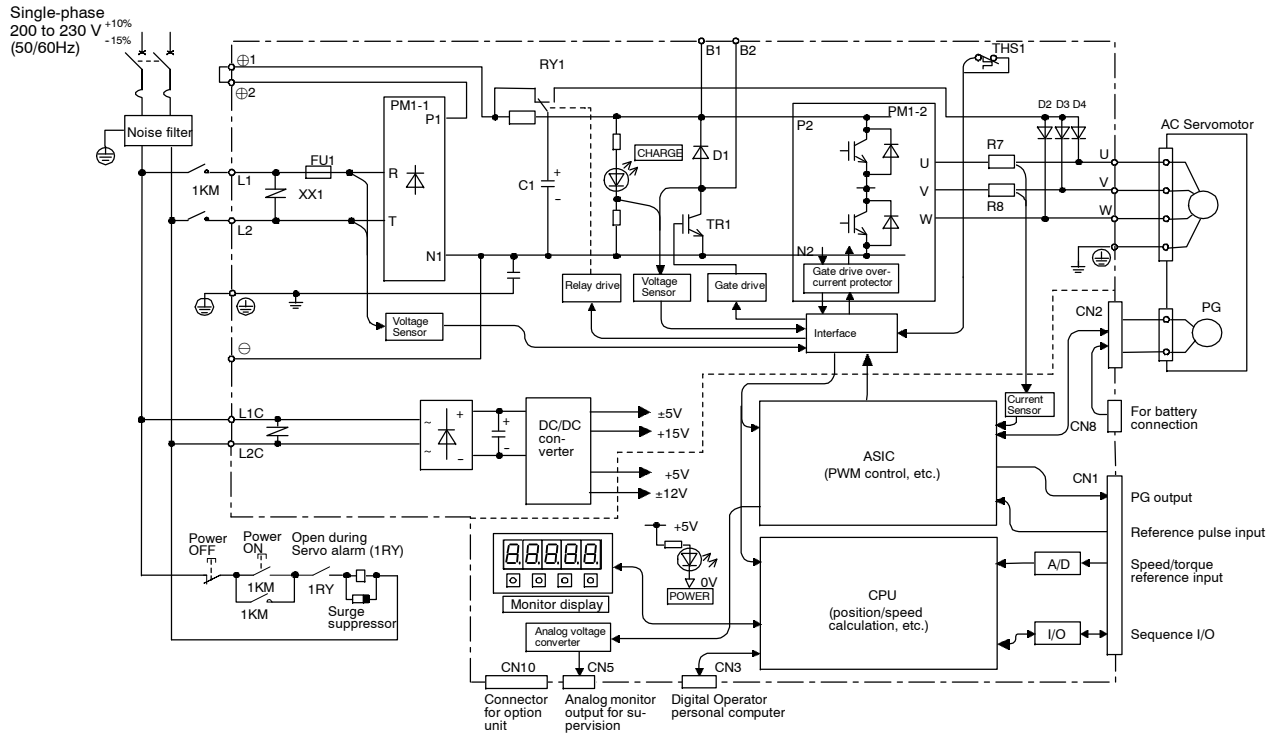

* The power supply voltage is 100 to 115 V $^{+10\%}_{-15\%}$ (50/60 Hz) for the 30 to 200 W 100-V models.

3.2.2 0.5 kW to 1.5 kW 200-V Models

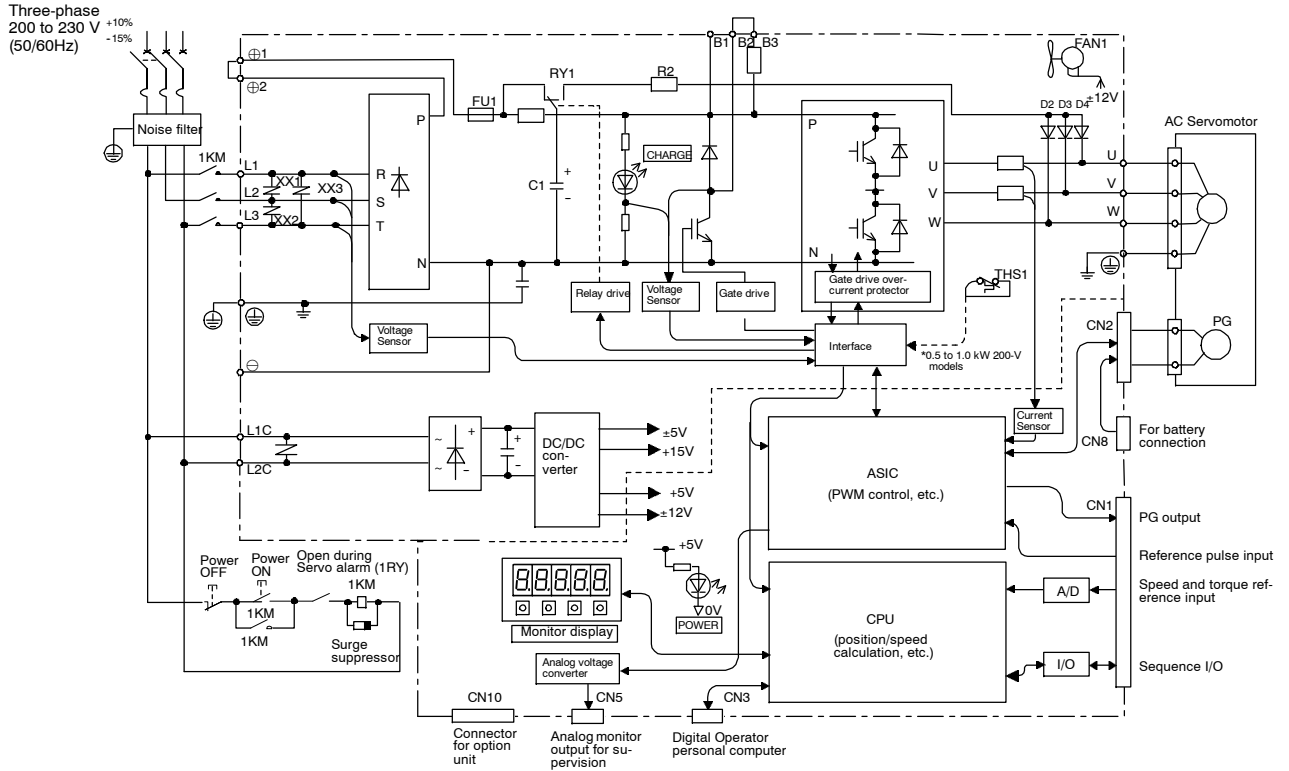

3.2.3 2.0 kW to 5.0 kW 200-V Models

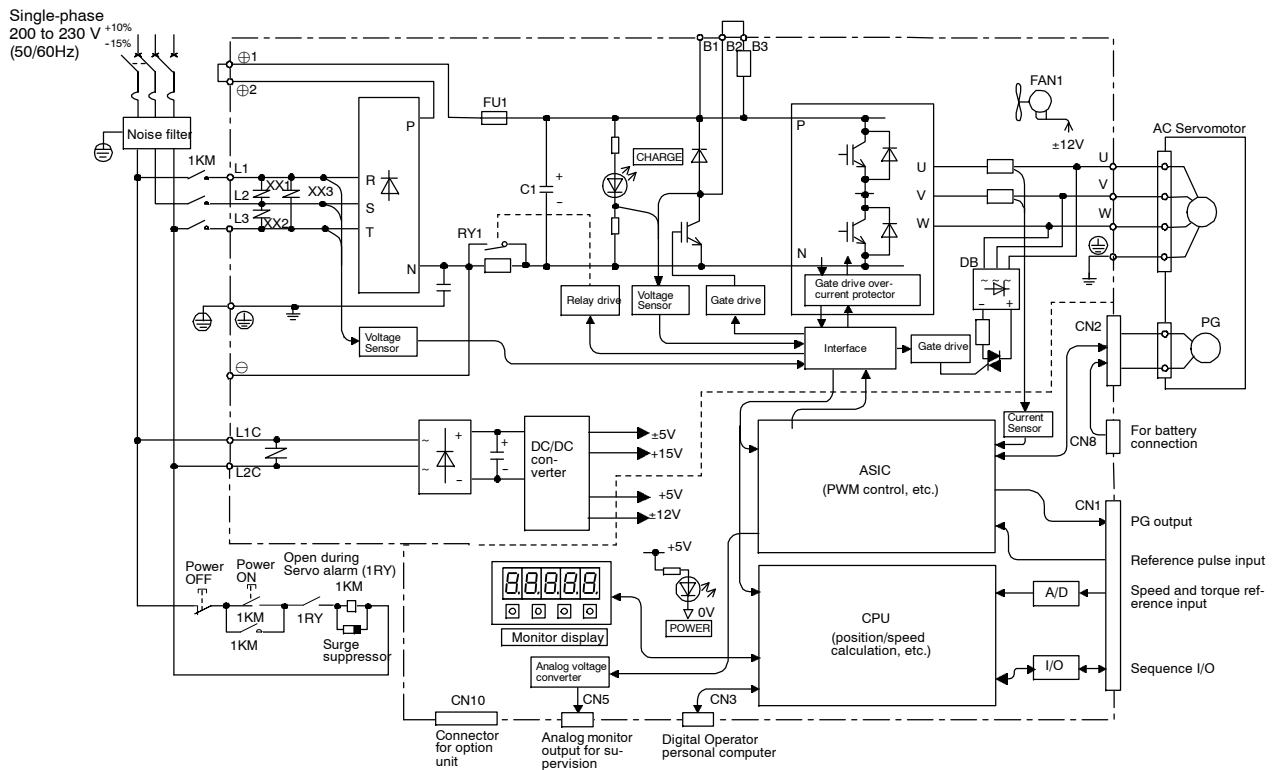

3.2.4 6.0 kW to 15.0 kW 200-V Models

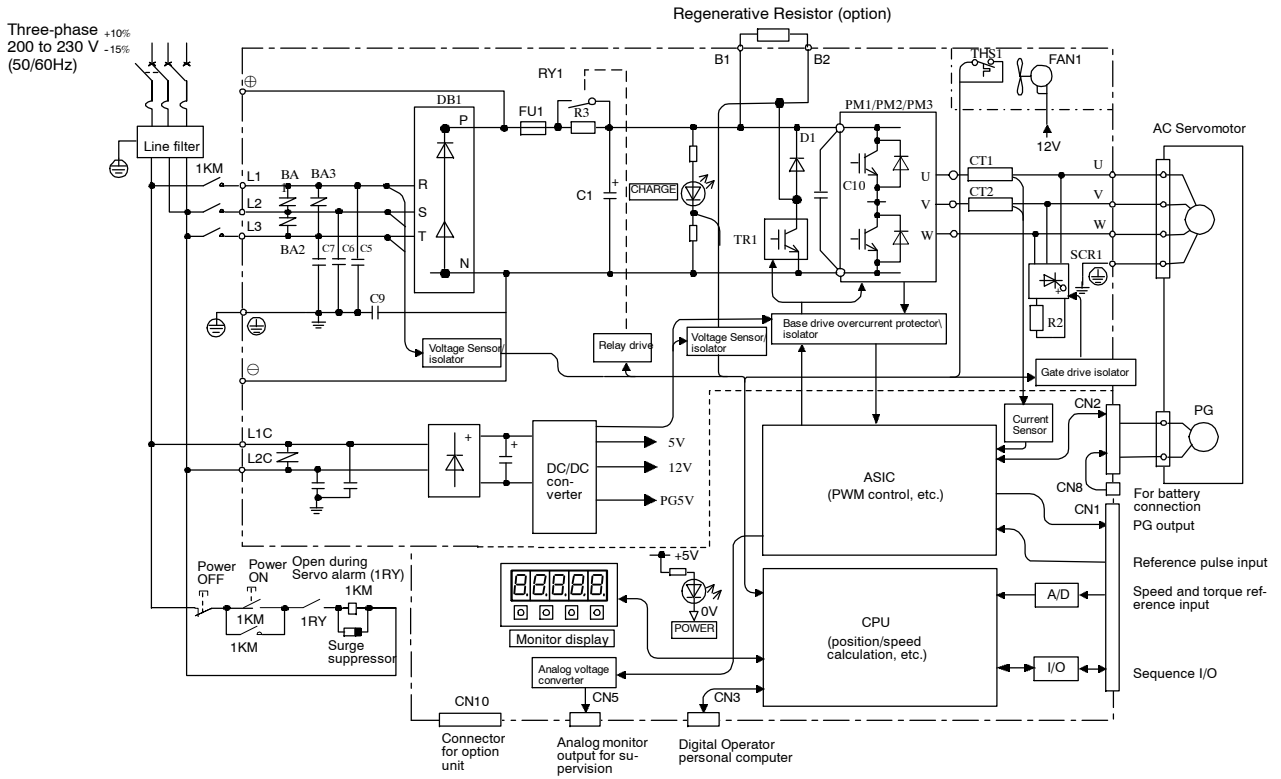

3

3.2.5 0.5 kW to 3.0 kW 400-V Models

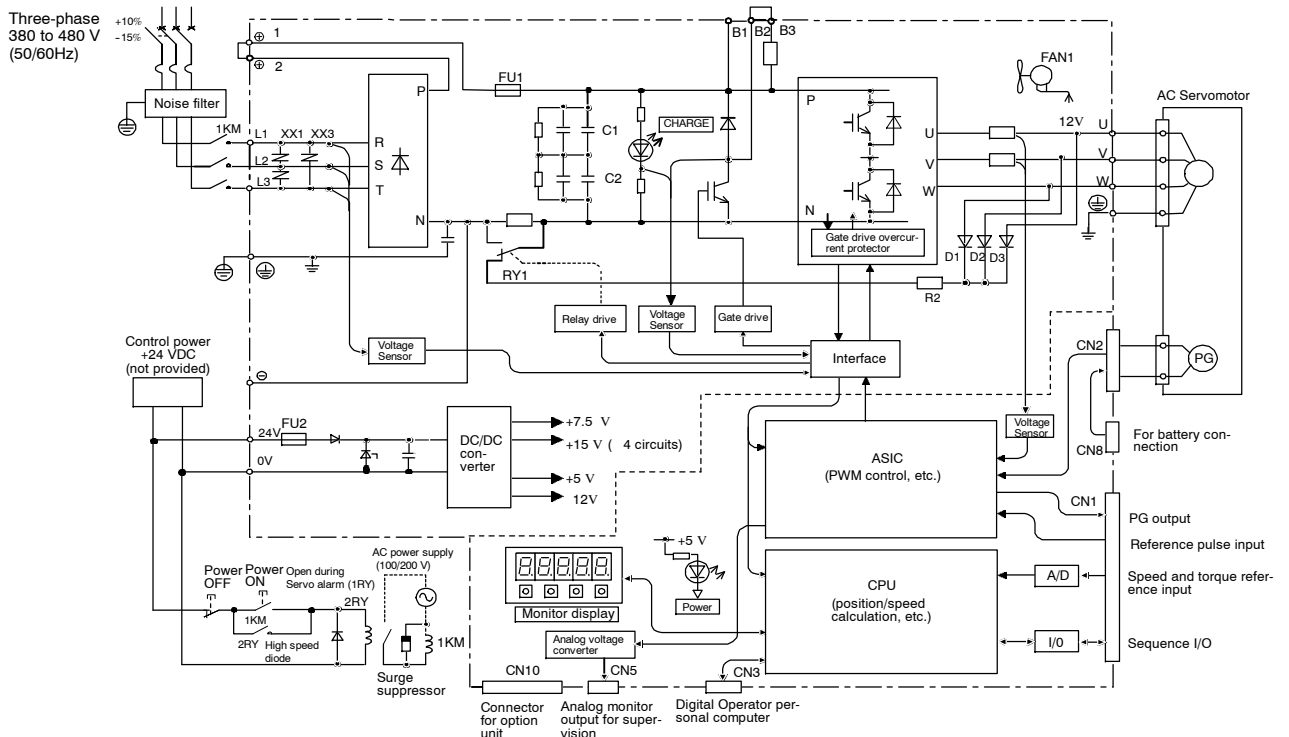

3.2.6 5.0 kW 400-V Models

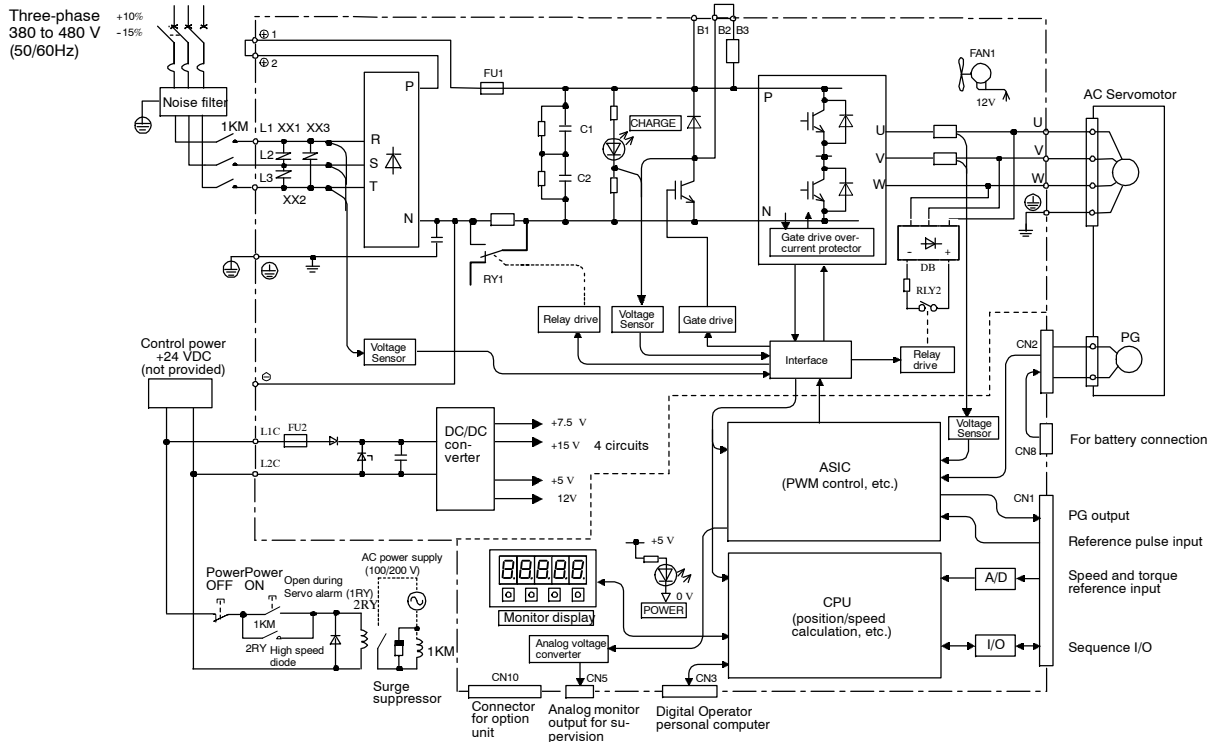

3.2.7 6.0 kW and 7.5 kW 400-V Models

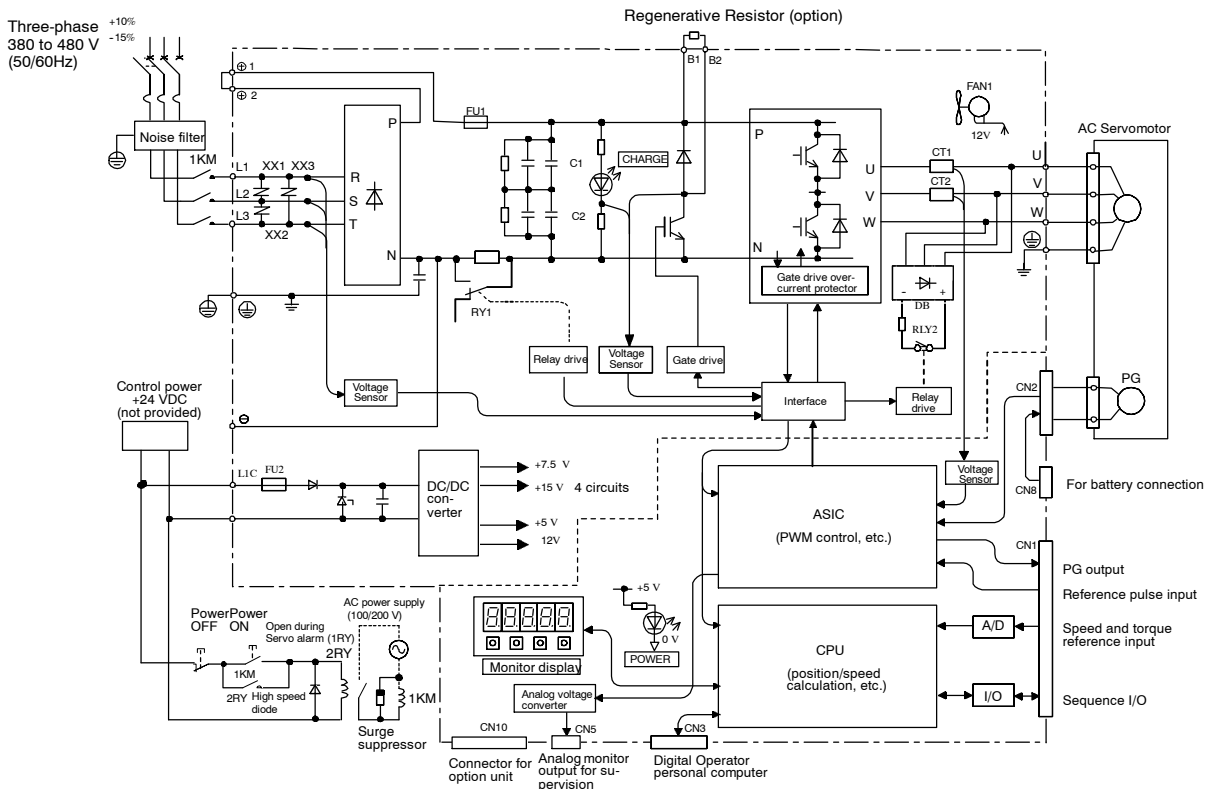

3.2.8 11.0 kW and 15.0 kW 400-V Models

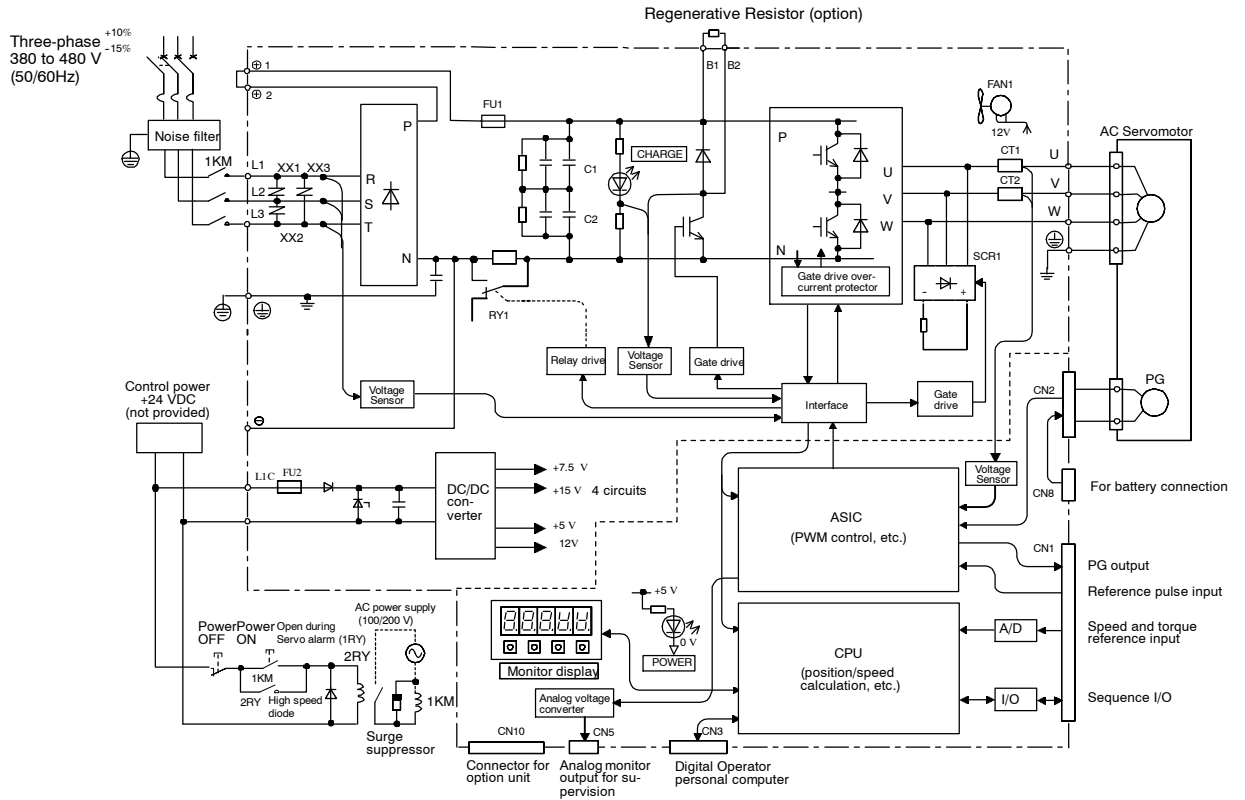

3

3.3 Main Circuit Wiring

This section shows typical examples of main circuit wiring for Σ -II Series servo products, functions of main circuit terminals, and the power ON sequence.

Observe the following precautions when wiring.

CAUTION

- Do not bundle or run power and signal lines together in the same duct. Keep power and signal lines separated by at least 30 cm (11.81 in).
- Use twisted-pair wires or multi-core shielded-pair wires for signal and encoder (PG) feedback lines.
The maximum length is 3 m (118.11 in) for reference input lines and is 20 m (787.40 in) for PG feedback lines.
- Do not touch the power terminals for 5 minutes after turning power OFF because high voltage may still remain in the Servopack.
Make sure the charge indicator is out first before starting an inspection.
- Avoid frequently turning power ON and OFF. Do not turn power ON or OFF more than once per minute.
Since the Servopack has a capacitor in the power supply, a high charging current flows for 0.2 seconds when power is turned ON. Frequently turning power ON and OFF causes main power devices like capacitors and fuses to deteriorate, resulting in unexpected problems.

3.3.1 Names and Descriptions of Main Circuit Terminals

Table 3.1 gives the names and a description of main circuit terminals.

Table 3.1 Main Circuit Names and Description

Name	Terminal Symbol	Main Circuit Voltage [V]	Maximum Applicable Servomotor Capacity [kW]	Description
Main circuit AC input terminal	L1, L2	100	0.03 to 0.2	Single-phase 100 to 115 VAC $+10\%$, -15% (50/60 Hz)
		200	0.03 to 0.4	Single-phase 200 to 230 VAC $+10\%$, -15% (50/60 Hz)
	L1, L2, L3*	200	0.5 to 15.0	Three-phase 200 to 230 VAC $+10\%$, -15% (50/60 Hz)
		400	0.5 to 15.0	Three-phase 380 to 480 VAC $+10\%$, -15% (50/60 Hz)
Servomotor connection terminal	U, V, W	-	-	Connects to the Servomotor.
Control power input terminal	L1C, L2C	100	0.03 to 0.2	Single-phase 100 to 115 VAC $+10\%$, -15% (50/60 Hz)
		200	0.03 to 15.0	Single-phase 200 to 230 VAC $+10\%$, -15% (50/60 Hz)
	24V, 0V	400	0.5 to 15.0	24VDC (15)
Ground terminal		-	-	Connects to the power supply ground terminals and motor ground terminal.
External regenerative resistor terminal	B1, B2	100	0.03 to 0.2	Normally not connected.
		200	0.03 to 0.4	Connect an external regenerative resistor (provided by customer) between B1 and B2 if the regenerative capacity is insufficient.
	B1, B2, B3	200	0.5 to 5.0	Normally short B2 and B3 (for an internal regenerative resistor).
		400	0.5 to 5.0	Remove the wire between B2 and B3 and connect an external regenerative resistor (provided by customer) between B1 and B2 if the capacity of the internal regenerative resistor is insufficient.
	B1, B2	200	6.0 to 15.0	Connect an external regenerative resistor (provided by customer) between terminals B1 and B2. Refer to 4.6 <i>Selecting a Regenerative Resistor</i> for details.
		400	6.0 to 15.0	
DC reactor terminal connection for power supply harmonic wave countermeasure	$\oplus 1, \oplus 2$	100	0.03 to 0.2	Normally short $\oplus 1$ and $\oplus 2$.
		200	0.03 to 5.0	If a countermeasure against power supply harmonic waves is needed, connect a DC reactor between $\oplus 1$ and $\oplus 2$.
		400	0.5 to 15.0	
		200	6.0 or more	These terminals do not exist.
Main circuit plus terminal	\oplus	200	6.0 or more	Normally not connected. Note: This terminal is on Servopacks with a capacity of 6 kW or higher only.
Main circuit minus terminal	\ominus	-	-	Normally not connected.

* SGDH-08AE-S Servopack (for SGMAH-08A, SGMPH-08A Servomotor) and SGDH-15AE-S Servopack (for SGMPH-15A Servomotor) have single-phase, 200 V power supply specifications. Connect the following power supply between L1 to L3.

Single-phase 220 to 230 VAC $+10\%$, -15% (50/60 Hz)

When a power supply of 187 V (-15% of 220 V) or less is used, alarm 41, indicating voltage shortage, may occur when accelerating to max speed with max torque of Servomotor.

3.3.2 Typical Main Circuit Wiring Example

The following figure shows a typical example of main circuit wiring (three-phase, 200 V).

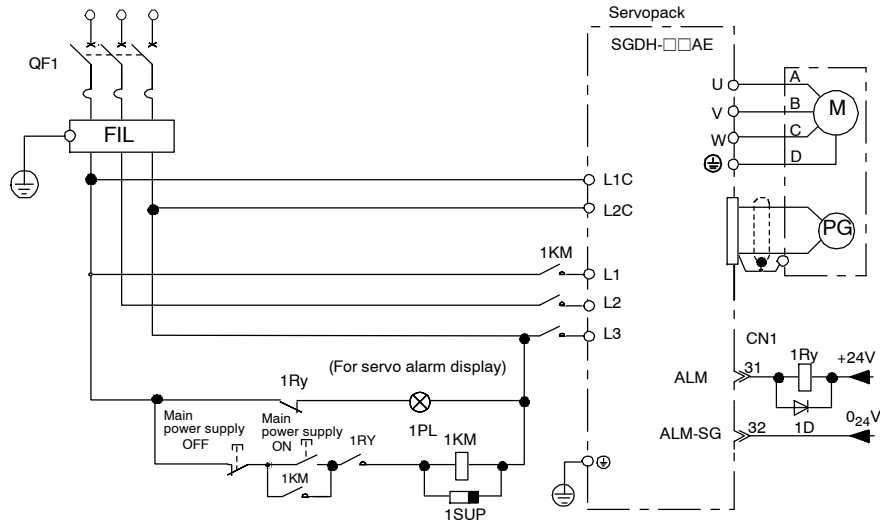

QF1: Molded-case circuit breaker (for the inverter)

FIL: Noise filter

1KM: Magnetic Contactor

1Ry: Relay

1PL: Indicator lamp

1SUP: Surge suppressor

1D: Flywheel diode

■ Designing a Power ON Sequence

Note the following points when designing the power ON sequence.

- Design the power ON sequence so that power is turned OFF when a servo alarm signal is output. (See the circuit figure above.)
- Hold the power ON button for at least two seconds. The Servopack will output a servo alarm signal for two seconds or less when power is turned ON. This is required in order to initialize the Servopack.

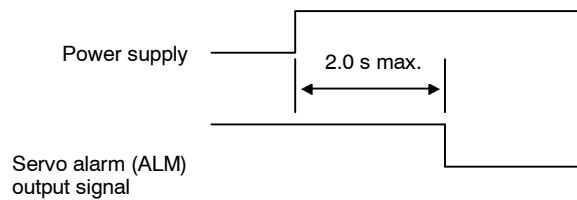

3.3.3 Cable Specifications and Peripheral Devices

Refer to the *SGM□H/SGDH User's Manual: Servo Selection and Data Sheets* (Manual No.: SIE-S800-32.1).

3.3.4 Servopack Power Losses

Table 3.2 shows Servopack power losses at the rated output.

Table 3.2 Servopack Power Losses at Rated Output

Main Circuit Power Supply	Maximum Applicable Servomotor Capacity [kW]	Servopack Model	Output Current (Effective Value) [A]	Main Circuit Power Loss [W]	Regenerative Resistor Power Loss [W]	Control Circuit Power Loss [W]	Total Power Loss [W]
Single-phase 100V	0.03	SGDH-A3BE	0.66	3.5	- *1	13	16.5
	0.05	SGDH-A5BE	0.95	5.2			18.2
	0.10	SGDH-01BE	2.4	12			25
	0.20	SGDH-02BE	3.0	16.4			29.4
Single-phase 200V	0.03	SGDH-A3AE	0.44	3.1	- *1	13	16.1
	0.05	SGDH-A5AE	0.64	4.6			17.6
	0.10	SGDH-01AE	0.91	6.7			19.7
	0.20	SGDH-02AE	2.1	13.3			26.3
	0.40	SGDH-04AE	2.8	20			33
	0.75	SGDH-08AE-S	4.4	47	12 ^{*2}	15	74
	1.50	SGDH-15AE-S	7.5	60	14 ^{*2}		89
Three-phase 200V	0.45	SGDH-05AE	3.8	27	12 ^{*2}	15	54
	0.75	SGDH-08AE	5.7	41			68
	1.0	SGDH-10AE	7.6	55			82
	1.5	SGDH-15AE	11.6	92	14 ^{*2}		121
	2.0	SGDH-20AE	18.5	120	28 ^{*2}		163
	3.0	SGDH-30AE	24.8	155			198
	5.0	SGDH-50AE	32.9	240	56 ^{*2}		311
	6.0	SGDH-60AE	46.9	290	- *3	27	317
	7.5	SGDH-75AE	54.7	330			357
	11.0	SGDH-1AAE	58.6	360		30	390
	15.0	SGDH-1EAE	78.0	490	520		
Three-phase 400V	0.45	SGDH-05DE	1.9	19	14 ^{*2}	15	48
	1.0	SGDH-10DE	3.5	35			64
	1.5	SGDH-15DE	5.4	53			82
	2.0	SGDH-20DE	8.4	83	28 ^{*2}		126
	3.0	SGDH-30DE	11.9	118			161
	5.0	SGDH-50DE	16.5	192			36
	6.0	SGDH-60DE	20.8	232	- *3		247
	7.5	SGDH-75DE	25.4	264			279
	11.0	SGDH-1ADE	28.1	288			303
	15.0	SGDH-1EDE	37.2	392		407	

- * **1.** Servopacks with a capacity of 30 to 400 W do not have built-in regenerative resistors. If the regenerative energy exceeds the specified value, connect an external regenerative resistor. Refer to 4.6.2 *Calculating the Required Capacity of Regenerative Resistors*.
- * **2.** Regenerative resistor power losses are allowable losses. Take the following action if this value is exceeded.
 - Remove the lead from the internal regenerative resistor in the Servopack.
 - Install an external regenerative resistor.
- * **3.** An external regenerative resistor must be connected to Servopacks with a capacity of 6.0 kW or higher. The following Regenerative Resistor Units are provided for this purpose.
 - For the SGDH-60AE: JUSP-RA04 (allowable loss: 180 W)
 - For the SGDH-60DE and 75DE: JUSP-RA18 (allowable loss: 180W)
 - For the SGDH-75AE to 1EAE: JUSP-RA05 (allowable loss: 350W)
 - For the SGDH-1ADE and 1EDE: JUSP-RA19 (allowable loss: 350W)

Note External Regenerative Resistor Units are optional. Refer to 4.6 *Selecting a Regenerative Resistor* for details.

3.3.5 Wiring Main Circuit Terminal Blocks

Observe the following precautions when wiring main circuit terminal blocks.

⚠ CAUTION

- Remove the terminal block from the Servopack prior to wiring.
- Insert only one wire per terminal on the terminal block.
- Make sure that the core wire is not electrically shorted to adjacent core wires.
- Reconnect any wires that were accidentally pulled out.

Servopacks with a capacity below 1.5 kW will have connector-type terminal blocks for main circuit terminals. Follow the procedure below when connecting to the terminal block.

■ Connection Procedure

1. Strip the end of the wire.

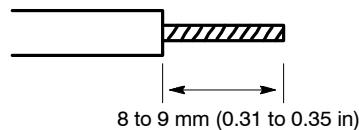

2. Open the wire terminal on the terminal block housing (plug) with the tool using the procedure shown in Fig. A or B.
 - Insert the hook end of the provided tool into the slot as shown in Fig. A. Press on the lever end to open the wire terminal.
 - Use a standard flat-blade screwdriver (blade width of 3.0 to 3.5 mm (0.12 to 0.14 in)). Put the blade into the slot, as shown in Fig. B, and press down firmly to open the wire terminal.

Either the procedure shown in Fig. A or B can be used to open the wire insert opening.

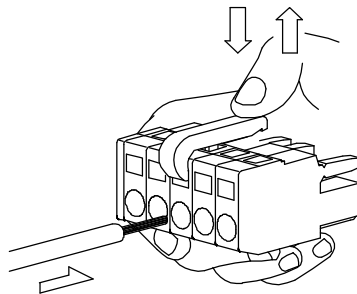

Fig. A

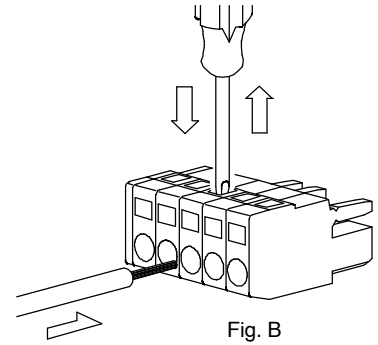

Fig. B

3. Insert the wire core into the opening and then close the opening by releasing the lever or removing the screwdriver.

■ Preparing the End of the Wire

Wire can be used simply by stripping back the outer coating. The following are applicable wire sizes.

- Single wire Ø0.5 to Ø1.6 mm
- Braided wire AWG28 to AWG12



The terminal block for Servopack SGDh- DE for 400 V 50 W to 1.5 kW, has an indication “300 V, 15 A”. This is a rating recognition of UL authorization, which means that the terminal blocks are authorized for “limited rating for industrial use” and applicable up to 600 V. Accordingly, these terminal blocks are applicable for Servopack for 400V.

3.4 I/O Signals

This section describes I/O signals for the SGDH Servopack.

3.4.1 Examples of I/O Signal Connections

The following diagram shows a typical example of I/O signal connections.

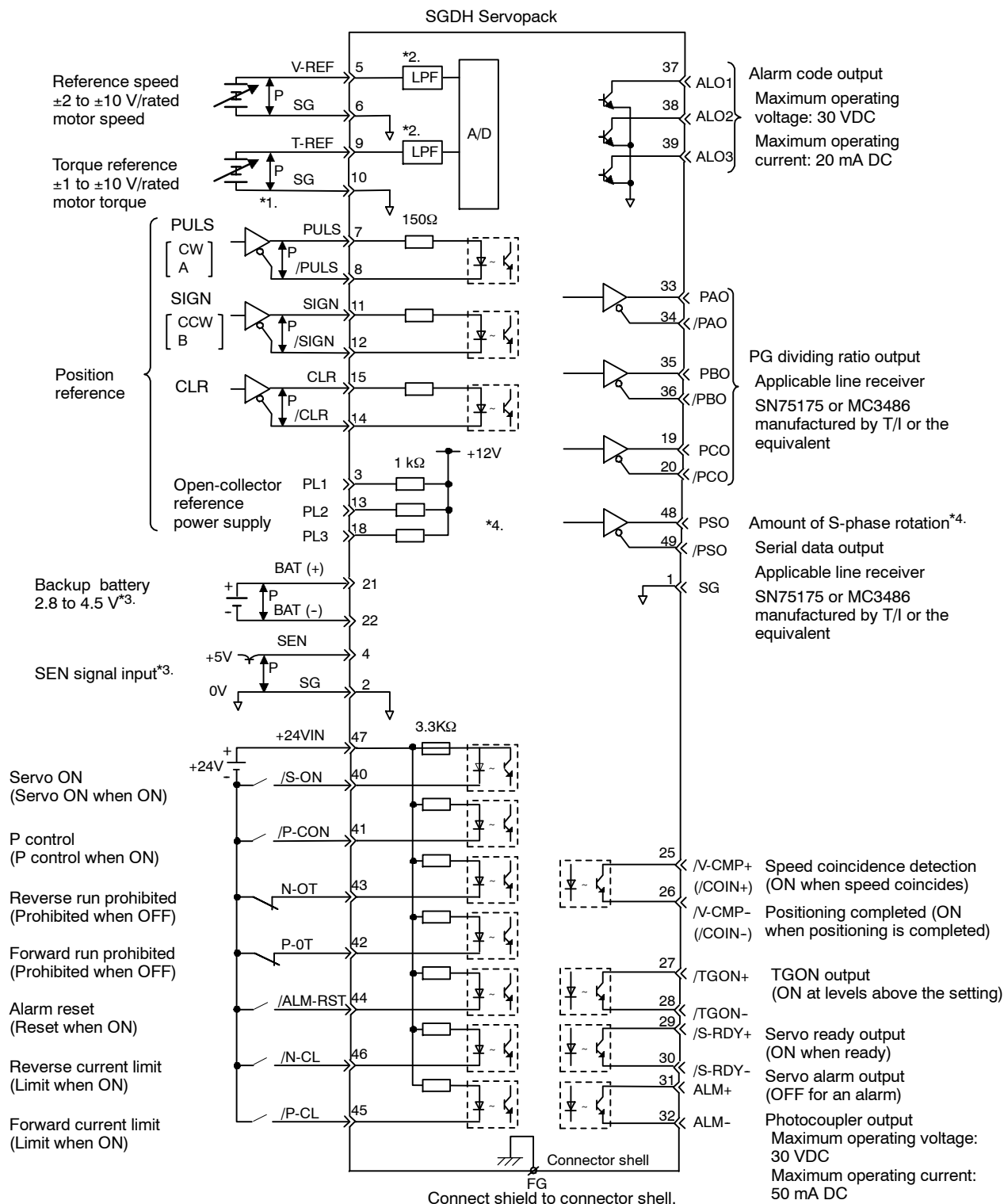

* 1. □P represents twisted-pair wires. * 3. Connect when using an absolute encoder.
 * 2. The time constant for the primary filter is 47 μs. * 4. Used only with an absolute encoder.

3.4.2 List of CN1 Terminals

The following diagram shows the layout and specifications of CN1 terminals.

■ CN1 Terminal Layout

2	SG	GND	1	SG	GND	26	/V-CMP- (/COIN-)	Speed coincidence detection output
4	SEN	SEN signal input	3	PL1	Open-collector reference power supply	27	/TGON+	TGON signal output
6	SG	GND	5	V-REF	Reference speed input	28	/TGON	TGON signal output
8	/PULS	Reference pulse input	7	PULS	Reference pulse input	29	/S-RDY+	Servo ready output
10	SG	GND	9	T-REF	Torque reference input	30	/S-RDY	Servo ready output
12	/SIGN	Reference symbol input	11	SIGN	Reference sign input	31	ALM+	Servo alarm output
14	/CLR	Clear input	13	PL2	Open-collector reference power supply	32	ALM	Servo alarm output
16	-	-	15	CLR	Clear input	33	PAO	PG divided output A-phase
18	PL3	Open-collector reference power supply	17	-	-	34	/PAO	PG divided output A-phase
20	/PCO	PG divided output C-phase	19	PCO	PG divided output C-phase	35	PBO	PG divided output B-phase
22	BAT (-)	Battery (-)	21	BAT (+)	Battery (+)	36	/PBO	PG divided output B-phase
24	-	-	23	-	-	37	ALO1	Alarm code output
			25	/V-CMP+ (/COIN+)	Speed coincidence detection output	38	ALO2	Alarm code output
						39	ALO3	(open-collector output)
						40	/S-ON	Servo ON input
						41	P-CON	P operation input
						42	P-OT	Forward over-travel input
						43	N-OT	Reverse over-travel input
						44	/ALM-RST	Alarm reset input
						45	/P-CL	Forward current limit ON input
						46	/N-CL	Reverse current limit ON input
						47	+24V -IN	External input power supply
						48	PSO	S-phase signal output
						49	/PSO	S-phase signal output
						50	-	-

Note 1. Do not use unused terminals for relays.

2. Connect the shield of the I/O signal cable to the connector shell.
Connect to the FG (frame ground) at the Servopack-end connector.

■ CN1 Specifications

Specifications for Servopack Connectors	Applicable Receptacles		
	Solder Type	Case	Manufacturer
10250-52A2JL or Equivalent 50-p Right Angle Plug	10150-3000VE	10350-52A0-008	Manufactured by Sumitomo 3M Co.

3.4.3 I/O Signal Names and Functions

The following section describes Servopack I/O signal names and functions.4.1.3

■ Input Signals

Signal Name		Pin No.	Function	Reference	
Common	/S-ON	40	Servo ON: Turns ON the servomotor when the gate block in the inverter is released.	4.5.2	
	/P-CON	41	Function selected via user constant.	4.2.1, 4.2.7	
			Proportional operation reference	Switches the speed control loop from PI (proportional/integral) to P (proportional) control when ON.	4.2.1
			Direction reference	With internal reference speed selected: Switches the direction of rotation.	4.2.6
			Control mode switching	Position ↔ speed Control ↔ torque Torque ↔ speed } Enables control mode switching.	4.2.7
			Zero-clamp reference	Speed control with zero-clamp function: Reference speed is zero when ON.	4.4.3
			Reference pulse block	Position control with reference pulse stop: Stops reference pulse input when ON.	4.2.12
	P-OT	42	Forward Run prohibited	Overtravel prohibited: Stops Servomotor when movable part travels beyond the allowable range of motion.	4.1.2
	N-OT	43	Reverse Run prohibited		
	/P-CL /N-CL	45	* Function selected via user constant.		---
		46	Forward current limit ON	Current limit function used when ON.	4.1.3
			Reverse current limit ON		
		46	Internal speed switching	With internal reference speed selected: Switches the internal speed settings.	4.2.6
	/ALM -RST	44	Alarm reset: Releases the servo alarm state.		4.5.1
	+24VIN	47	Control power supply input for sequence signals: Users must provide the +24-V power supply. Allowable voltage fluctuation range: 11 to 25 V		4.2.4
SEN	4 (2)	Initial data request signal when using an absolute encoder.		4.2.3	
BAT (+) BAT (-)	21 22	Connecting pin for the absolute encoder backup battery.		4.2.3	
Speed	V-REF	5 (6)	Speed reference speed input: ±2 to ±10 V/rated motor speed (Input gain can be modified using a user constant.)	4.2.1	

Signal Name		Pin No.	Function	Reference		
Torque	T-REF	9 (10)	Torque reference input: ± 1 to ± 10 V/rated motor torque (Input gain can be modified using a parameter.)	4.2.7		
Position Reference	PULS /PULS	7	Corresponds to reference pulse input	Input mode <ul style="list-style-type: none"> • Code + pulse string • CCW/CW pulse • Two-phase pulse (90° phase differential) 	4.2.2	
	SIGN /SIGN	8				Line-driver
		11				Open-collector
		12				
	CLR /CLR	15 14	Error counter clear: Clears the error counter during position control.		4.2.2	
	PL1 PL2 PL3	3 13 18	+12-V pull-up power supply when PULS, SIGN and CLR reference signals are open-collector outputs (+12-V power supply is built into the Servopack).		4.2.2	

Note 1. The functions allocated to /S-ON, /P-CON, P-OT, N-OT, /ALM-RST, /P-CL, and /N-CL input signals can be changed via user constants. (See 4.3.3 *Input Circuit Signal Allocation*.)

- Pin numbers in parenthesis () indicate signal grounds.
- The voltage input range for speed and torque references is a maximum of ± 12 V.

■ Output Signals

Signal Name		Pin No.	Function	Reference	
Common	ALM+ ALM-	31 32	Servo alarm: Turns OFF when an error is detected.	4.5.1	
	/TGON+ /TGON-	27 28	Detection during Servomotor rotation: Detects whether the Servomotor is rotating at a speed higher than the motor speed setting. Motor speed detection can be set via user constant.	4.5.5	
	/S-RDY + /S-RDY -	29 30	Servo ready: ON if there is no servo alarm when the control/main circuit power supply is turned ON.	4.5.6	
	PAO /PAO PBO /PBO PCO /PCO	33 (1) 34 35 36 19 20	A phase signal B phase signal C phase signal	Converted two-phase pulse (A and B phase) encoder output signal and origin pulse (C phase) signal: RS-422 or the equivalent	4.2.3
	PSO /PSO	48 49	S phase signal	With an absolute encoder: Outputs serial data corresponding to the number of revolutions (RS-422 or equivalent)	4.2.3
	ALO1 ALO2 ALO3	37 38 39 (1)	Alarm code output: Outputs 3-bit alarm codes. Open-collector: 30 V and 20 mA rating maximum		4.5.1
	FG	Shell	Connected to frame ground if the shield wire of the I/O signal cable is connected to the connector shell.		

Signal Name		Pin No.	Function	Reference
Speed	/V-CMP	25	Speed coincidence (output in Speed Control Mode): Detects whether the motor speed is within the setting range and if it matches the reference speed value.	4.5.4
	+ /V-CMP -	26		
Position	/COIN+	25	Positioning completed (output in Position Control Mode): Turns ON when the number of error pulses reaches the value set. The setting is the number of error pulses set in reference units (input pulse units defined by the electronic gear).	4.5.3
	/COIN-	26		
Not used.		16	These terminals are not used. Do not connect relays to these terminals.	---
		17		
		23		
		24		
		50		

Note 1. Pin numbers in parenthesis () indicate signal grounds.

2. The functions allocated to /TGON, /S-RDY, and /V-CMP (/COIN) can be changed via user constants. /CLT, /VCT, /BK, /WARN, and /NEAR signals can also be changed. (See 4.3.4 *Output Circuit Signal Allocation*).

3.4.4 Interface Circuits

This section shows examples of Servopack I/O signal connection to the host controller.

Interface for Reference Input Circuits

Analog Input Circuit

Analog signals are either speed or torque reference signals at the impedance below.

- Reference speed input: About 14 kΩ
- Reference torque input: About 14 kΩ

The maximum allowable voltages for input signals is ±12 V.

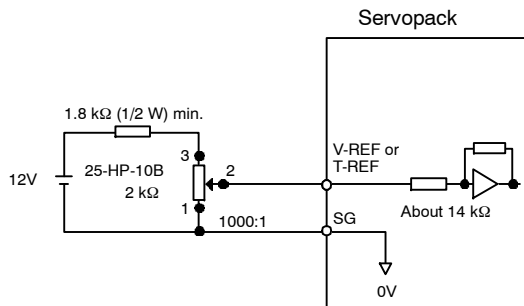

Reference Position Input Circuit

An output circuit for the reference pulse and error counter clear signal at the host controller can be either line-driver or open-collector outputs. These are shown below by type.

- Line-driver Output

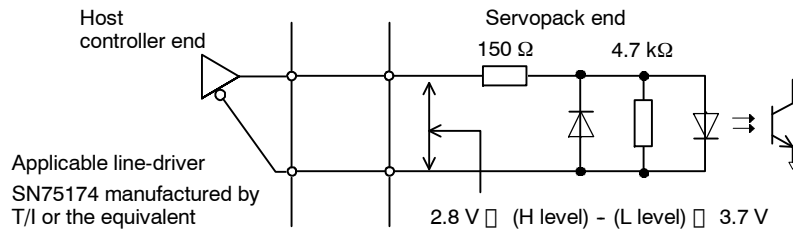

- Open-collector Output, Example 1: Power Supply Provided by User

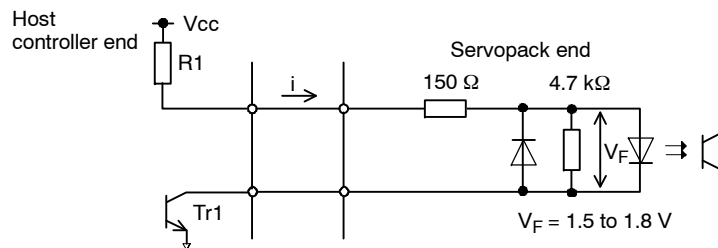

Use the examples below to set pull-up resistor R1 so the input current, i, falls between 7 and 15 mA.

Application Examples		
R1 = 2.2 kΩ with a V _{CC} of 24 V ±5%	R1 = 1 kΩ with a V _{CC} of 12 V ±5%	R1 = 180 Ω with a V _{CC} of 5 V ±5%

3

- Open-collector Output, Example 2: Using 12-V Power Supply Built into Servopack

This circuit uses the 12-V power supply built into the Servopack. The input is not insulated in this case.

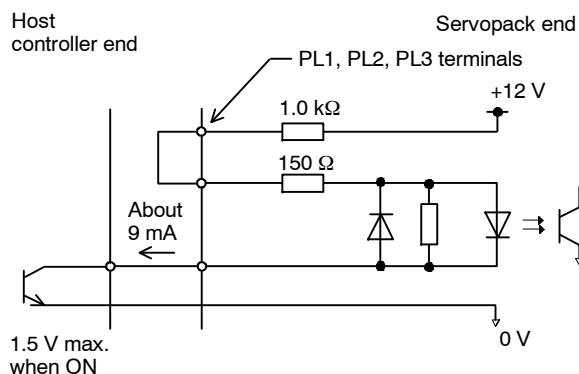

■ Sequence Input Circuit Interface

The sequence input circuit interface connects through a relay or open-collector transistor circuit. Select a low-current relay otherwise a faulty contact will result.

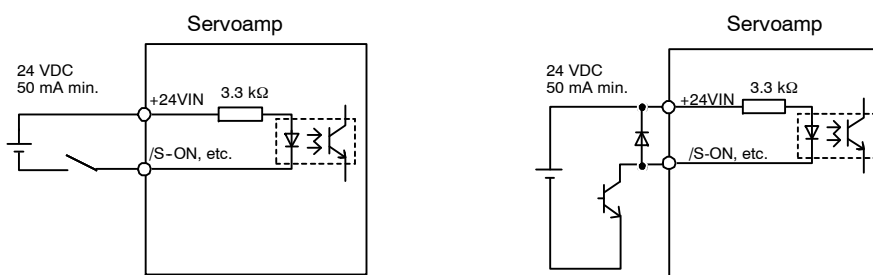

■ Output Circuit Interfaces

Any of the following three types of Servopack output circuits can be used. Form an input circuit at the host controller that matches one of these types.

- Connecting to a Line-driver Output Circuit

Encoder serial data converted to two-phase (A and B phase) pulse output signals (PAO, /PAO, PBO, /PBO), origin pulse signals (PCO, /PCO) and S phase rotation signals (PCO, /PCO) are output via line-driver output circuits that normally comprise the position control system at the host controller. Connect the line-driver output circuit through a line receiver circuit at the host controller.

See 3.5 *Wiring to an Encoder* for connection circuit examples.

● Connecting to an Open-collector Output Circuit

Alarm code signals are output from open-collector transistor output circuits.

Connect an open-collector output circuit through a photocoupler, relay or line receiver circuit.

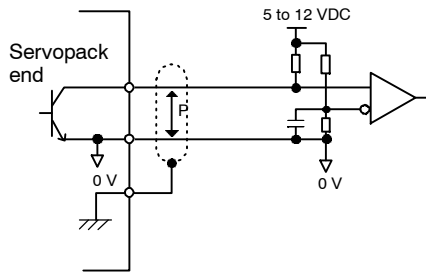
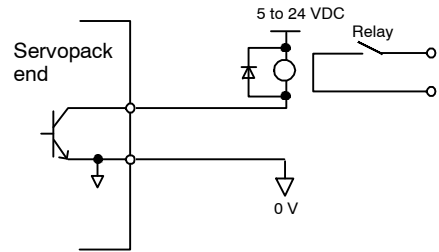
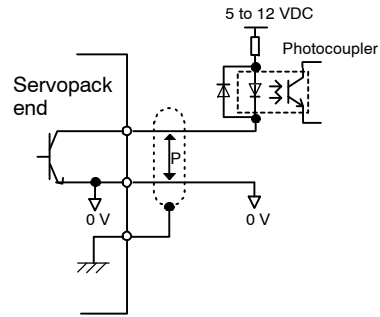

Note The maximum allowable voltage and current capacities for open-collector output circuits are as follows.
 ·Voltage: 30 VDC max.
 ·Current: 20 mA DC max.

● Connecting to a Photocoupler Output Circuit

Photocoupler output circuits are used for servo alarm, servo ready, and other sequence output signal circuits.

Connect a photocoupler output circuit through a relay or line receiver circuit.

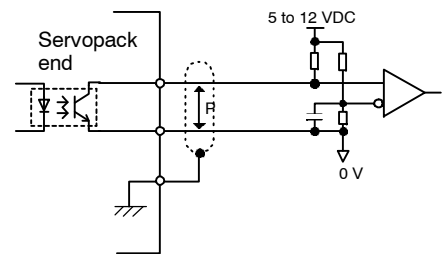
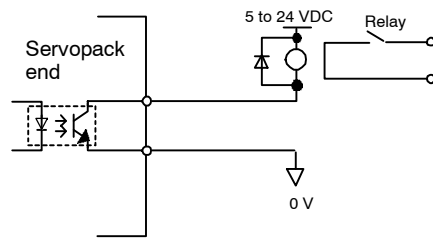

Note The maximum allowable voltage and current capacities for photocoupler output circuits are as follows.
 ·Voltage: 30 VDC max.
 ·Current: 50 mA DC max.

3

3.5 Wiring Encoders

The following sections describe the procedure for wiring a Servopack to the encoder.

3.5.1 Connecting an Encoder (CN2) and Output Signals from the Servopack (CN1)

The following diagrams show wiring for incremental and absolute encoders.

■ Incremental Encoders

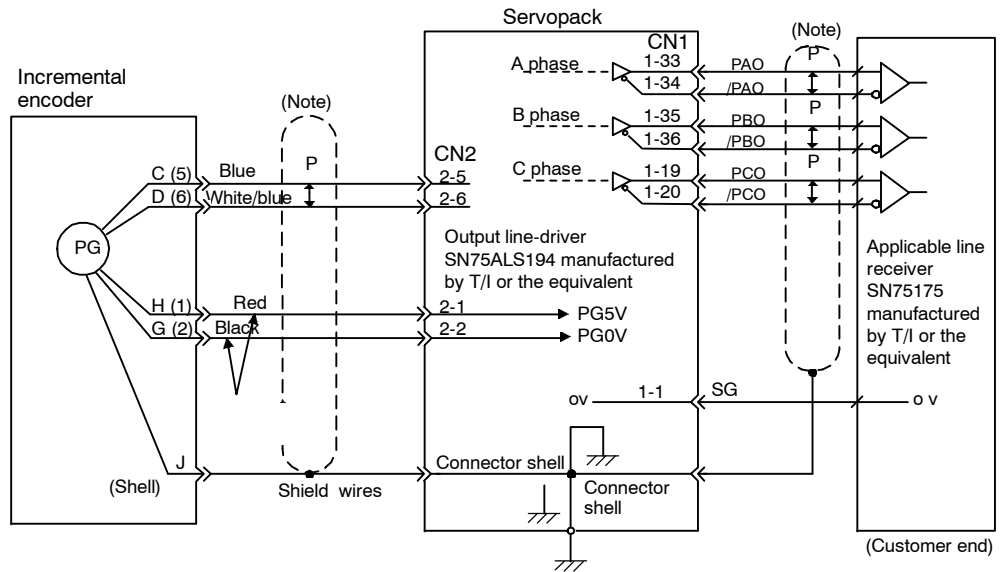

■ Absolute Encoders

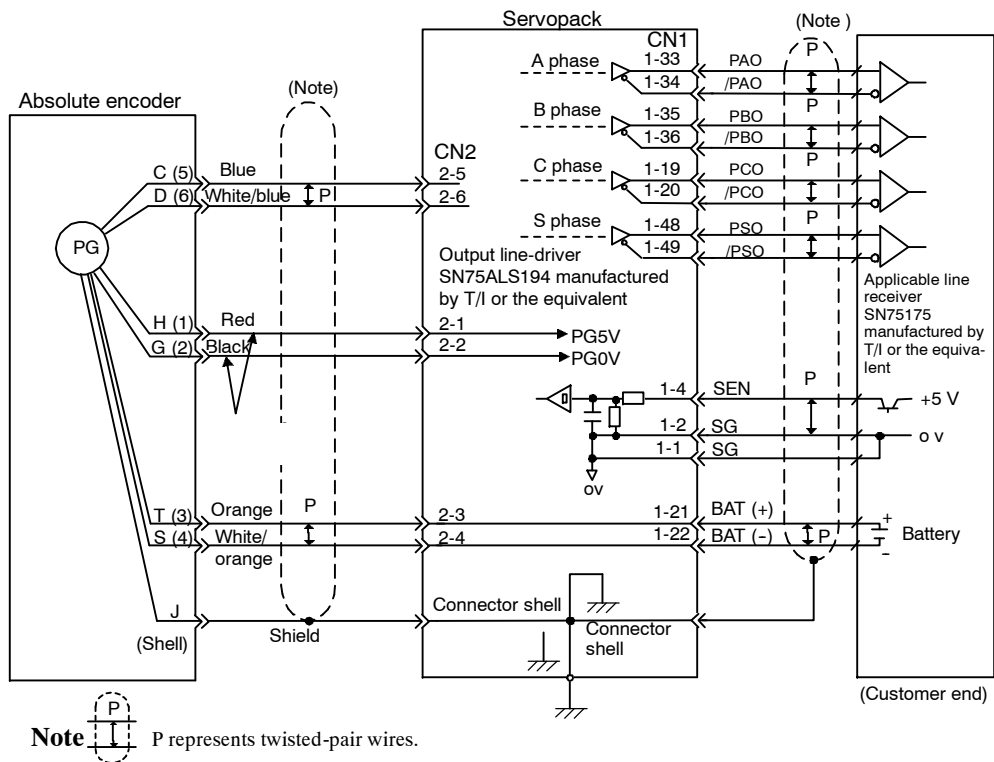

3.5.2 CN2 Encoder Connector Terminal Layout and Types

The following tables describe CN2 connector terminal layout and types.

■ CN2 Connector Terminal Layout

1	PG5V	PG power supply +5 V	2	PG 0 V	PG power supply 0 V
3	BAT (+)	Battery (+) (For an absolute encoder)	4	BAT (-)	Battery (-) (For an absolute encoder)
5	PS	PG serial signal input	6	/PS	PG serial signal input

■ CN2 Connector Models

Servopack Connectors	Applicable Plug (or Socket)		
	Soldered Relay Plug (Servopack Connector)	Soldered Relay Plug (Servomotor Connector)	Manufacturer
53460-0611	55100-0600	54280-0600	Molex Japan Co., Ltd.

Note 1. FA1394 is the product number for the Servopack-end plug and the Servomotor-end socket set from Molex Japan Co., Ltd.

2. The Servomotor-end relay socket connects to the encoder connector for the SGMAH and SGMPH Servomotor.
3. The following encoder connectors are for the SGMGH, SGMSH and SGMDH Servomotor.
 - L-shaped plug: MS3108B20-29S or
 - Straight: MS3106B20-29S
 - Cable clamp: MS3057-12A



Encoder cables are available from Yaskawa. See the data sheets below for more details on the cables.

- Refer to Σ -II Series SGM□H/SGDH User's Manual: Servo Selection and Data Sheets (Manual No.: SIE-S800-32.1).

3.6 Examples of Standard Connections

The following diagrams show examples of standard Servopack connections by specifications and type of control. Design the circuit so that the main circuit power supply turns OFF at emergency stop.

3.6.1 Single-phase Power Supply Specifications

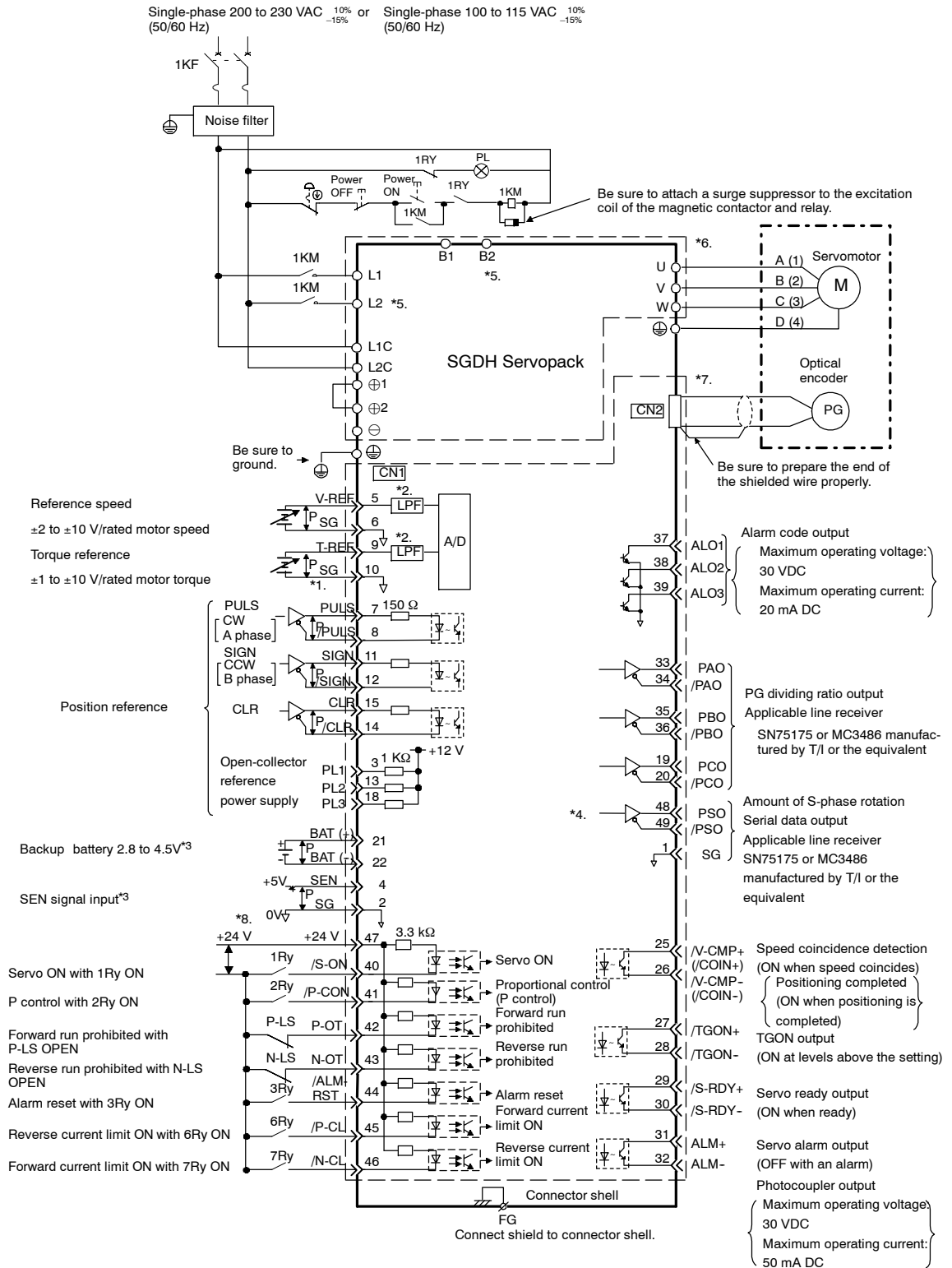

3

3.6.1 Single-phase Power Supply Specifications

- * 1. □P represents twisted-pair wires.
- * 2. The time constant for the primary filter is 47 μ s.
- * 3. Connect when using an absolute encoder.
- * 4. Used only with an absolute encoder.
- * 5. SGMH-08AE-S and SGDH-15AE-S Servopack have changed from three-phase specifications to single-phase power supply specifications. Main circuit connection terminals (L1, L2, L3) remain. These Servopacks have terminal B3 and internal regenerative resistor. Observe the following points.
 1. Connect main power supply shown below to L1 to L3 terminals.

Single-phase 220 to 230 VAC +10% to -15%, 50/60 Hz

If a power supply of 187 V (-15% of 220 V) or less is used, alarm A41 indicating voltage shortage, may occur when accelerating to max speed with max torque of Servomotor.
 2. Short-circuit B2 - B3 terminals using the internal regenerative resistor. If the capacity of the regenerative resistor is insufficient, remove the lead between B2 and B3 terminals, and connect external regenerative resistor unit to the B1 - B2 terminals.
- * 6. These circuits are hazardous and therefore, are separated by protecting separator.
- * 7. These circuits are SELV circuits and are separated from all other circuits by double and reinforced insulation.
- * 8. Use a double-insulated 24-VDC power supply.

3.6.2 Three-phase Power Supply Specifications (200 V)

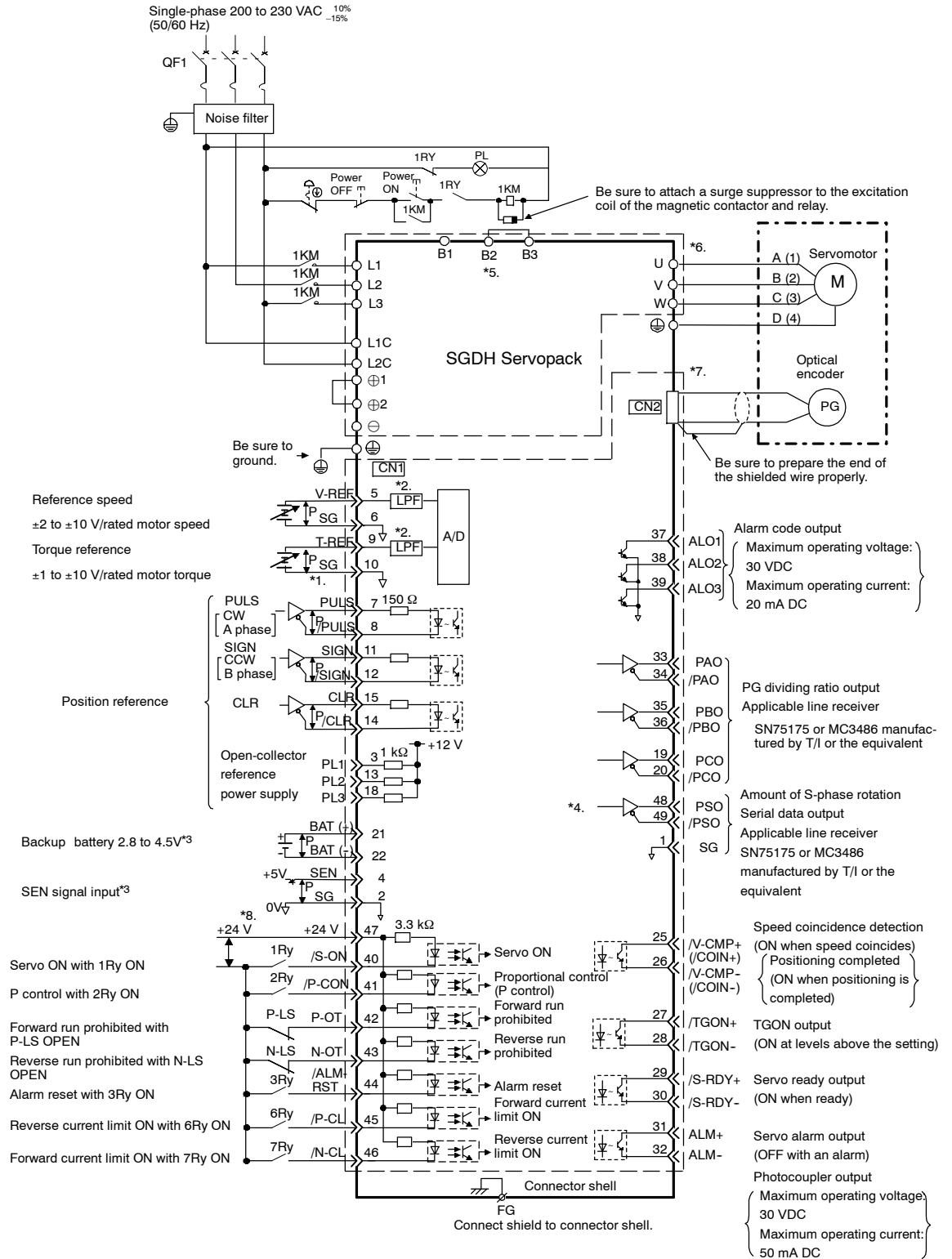

3

3.6.2 Three-phase Power Supply Specifications (200 V)

- * 1. □P represents twisted-pair wires.
- * 2. The time constant for the primary filter is 47 μ s.
- * 3. Connect when using an absolute encoder.
- * 4. Used only with an absolute encoder.
- * 5. Connect an external regenerative resistor between terminals B1 and B2 for Servopacks with a capacity of 6.0 kW or higher. (There is no terminal B3 on these Servopacks.)
- * 6. These circuits are hazardous and therefore, are separated by protecting separator.
- * 7. These circuits are SELV circuits and are separated from all other circuits by double and reinforced insulation.
- * 8. Use a double-insulated 24-VDC power supply.

3.6.3 Three-phase Power Supply Specifications (400 V)

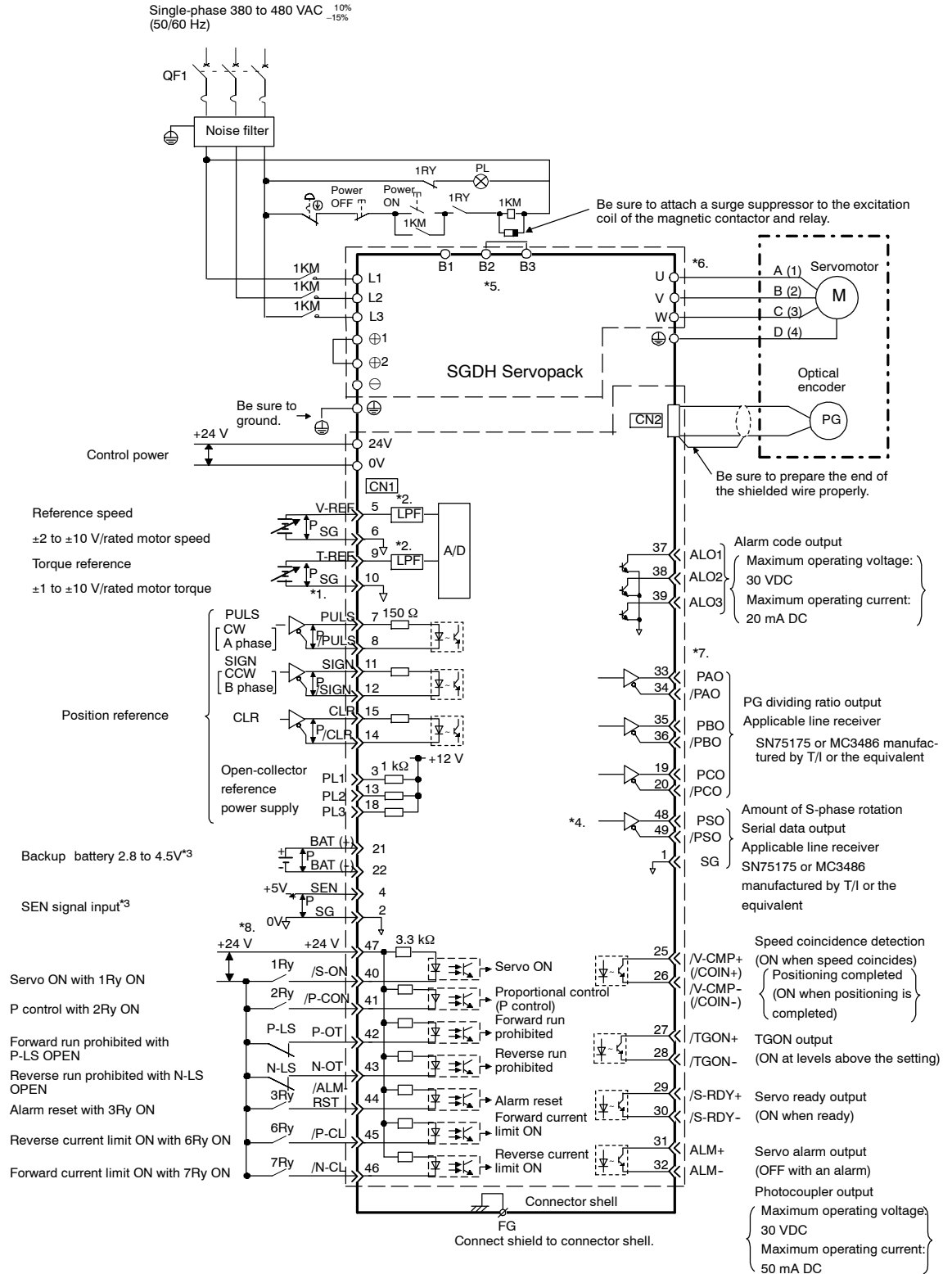

3

3.6.3 Three-phase Power Supply Specifications (400 V)

- * 1. □P represents twisted-pair wires.
- * 2. The time constant for the primary filter is 47 μ s.
- * 3. Connect when using an absolute encoder.
- * 4. Used only with an absolute encoder.
- * 5. Connect an external regenerative resistor between terminals B1 and B2 for Servopacks with a capacity of 6.0 kW or higher. (There is no terminal B3 on these Servopacks.)
- * 6. These circuits are hazardous and therefore, are separated by protecting separator.
- * 7. These circuits are SELV circuits and are separated from all other circuits by double and reinforced insulation.
- * 8. Use a double-insulated 24-VDC power supply.

3.6.4 Position Control Mode

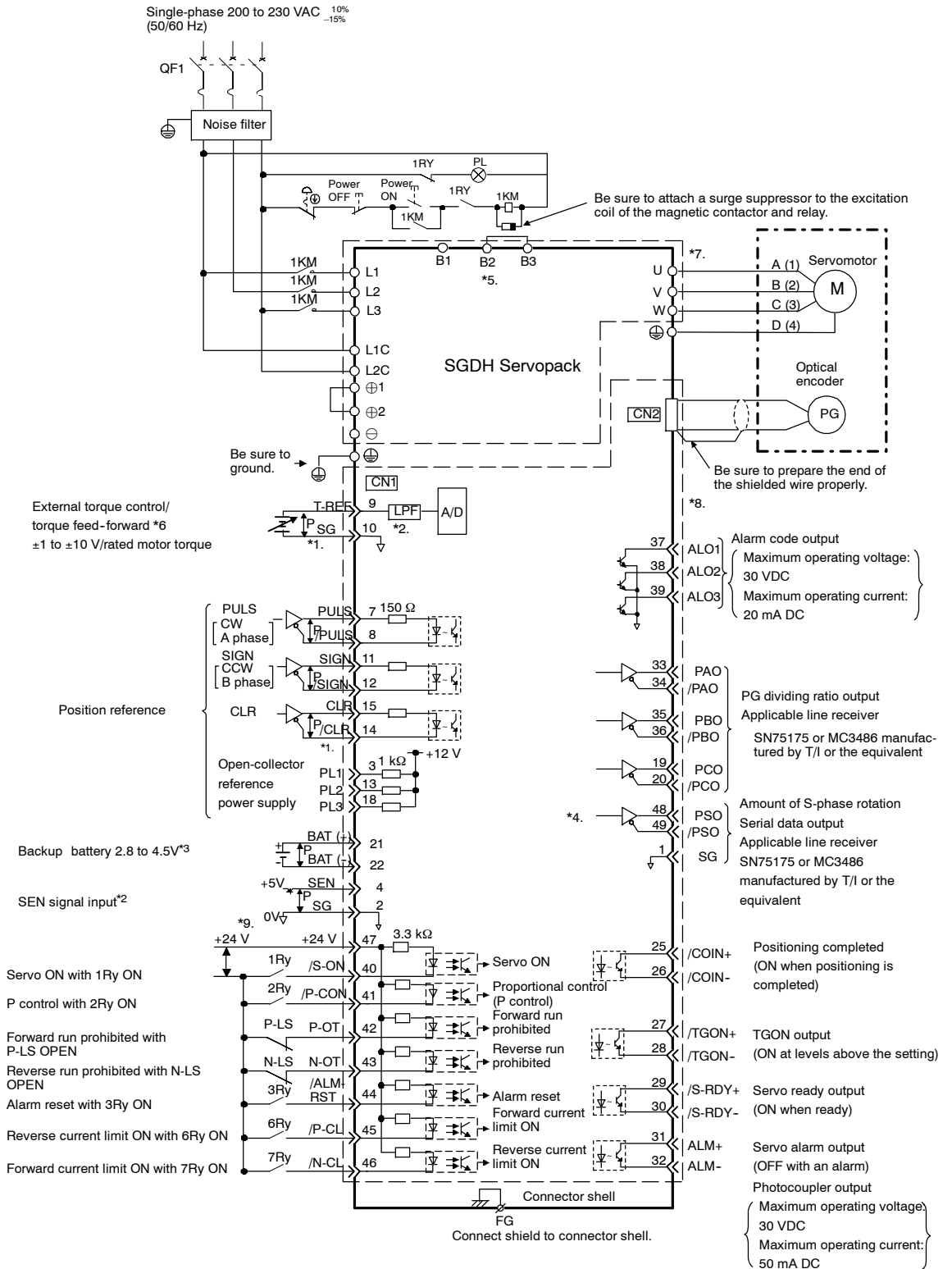

3

3.6.4 Position Control Mode

- * 1. □P represents twisted-pair wires.
- * 2. The time constant for the primary filter is 47 μ s.
- * 3. Connect when using an absolute encoder.
- * 4. Used only with an absolute encoder.
- * 5. Connect an external regenerative resistor between terminals B1 and B2 for Servopacks with a capacity of 6.0 kW or higher. (There is no terminal B3 on these Servopacks.)
- * 6. Set via user constant.
- * 7. These circuits are hazardous and therefore, are separated by protecting separator.
- * 8. These circuits are SELV circuits and are separated from all other circuits by double and reinforced insulation.
- * 9. Use a double-insulated 24-VDC power supply.

3.6.5 Speed Control Mode

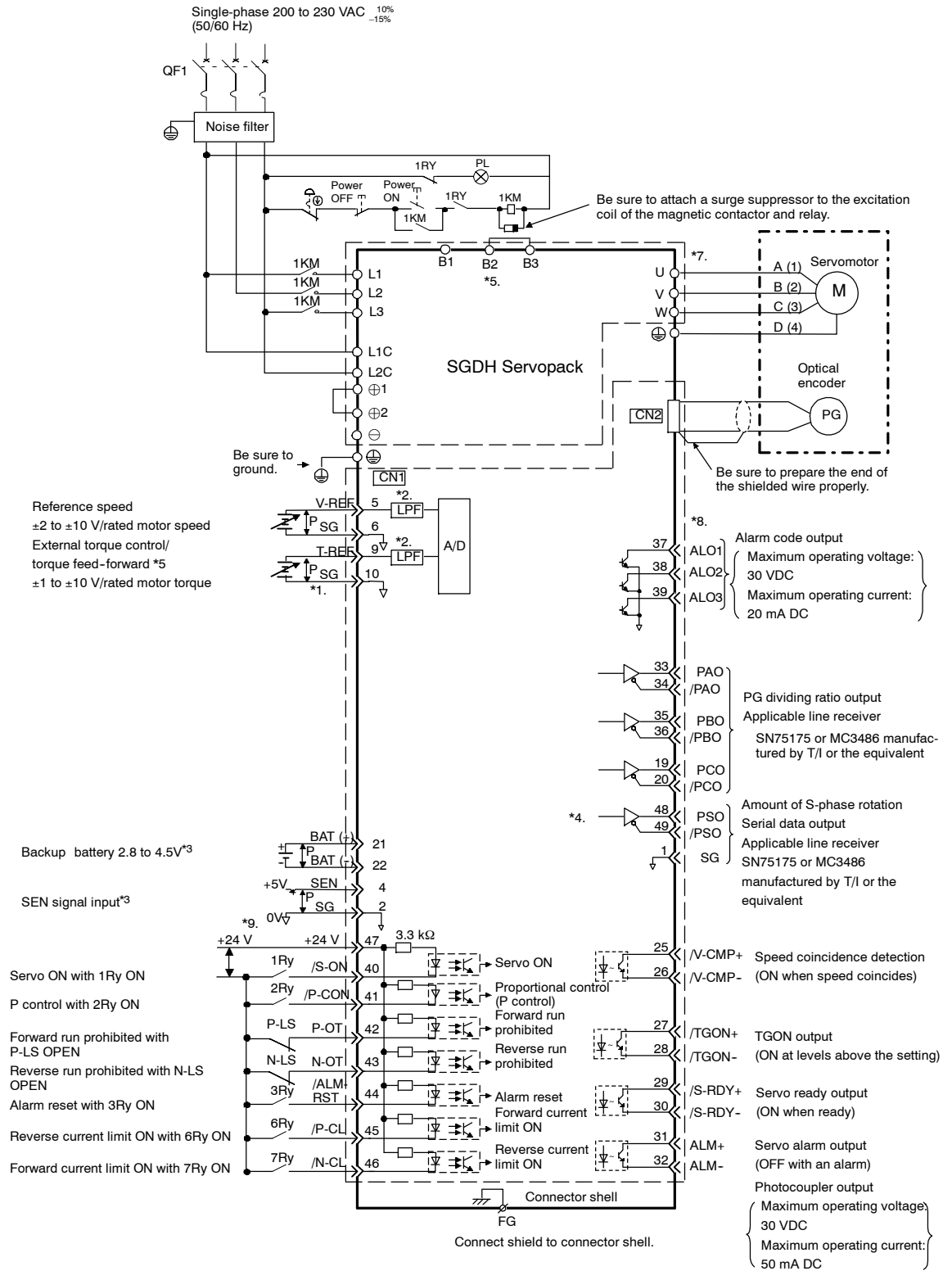

3

3.6.5 Speed Control Mode

- * 1. □P represents twisted-pair wires.
- * 2. The time constant for the primary filter is 47 μ s.
- * 3. Connect when using an absolute encoder.
- * 4. Used only with an absolute encoder.
- * 5. Set via user constant.
- * 6. Connect an external regenerative resistor between terminals B1 and B2 for Servopacks with a capacity of 6.0 kW or higher. (There is no terminal B3 on these Servopacks.)
- * 7. These circuits are hazardous and therefore, are separated by protecting separator.
- * 8. These circuits are SELV circuits and are separated from all other circuits by double and reinforced insulation.
- * 9. Use a double-insulated 24-VDC power supply.

3.6.6 Torque Control Mode

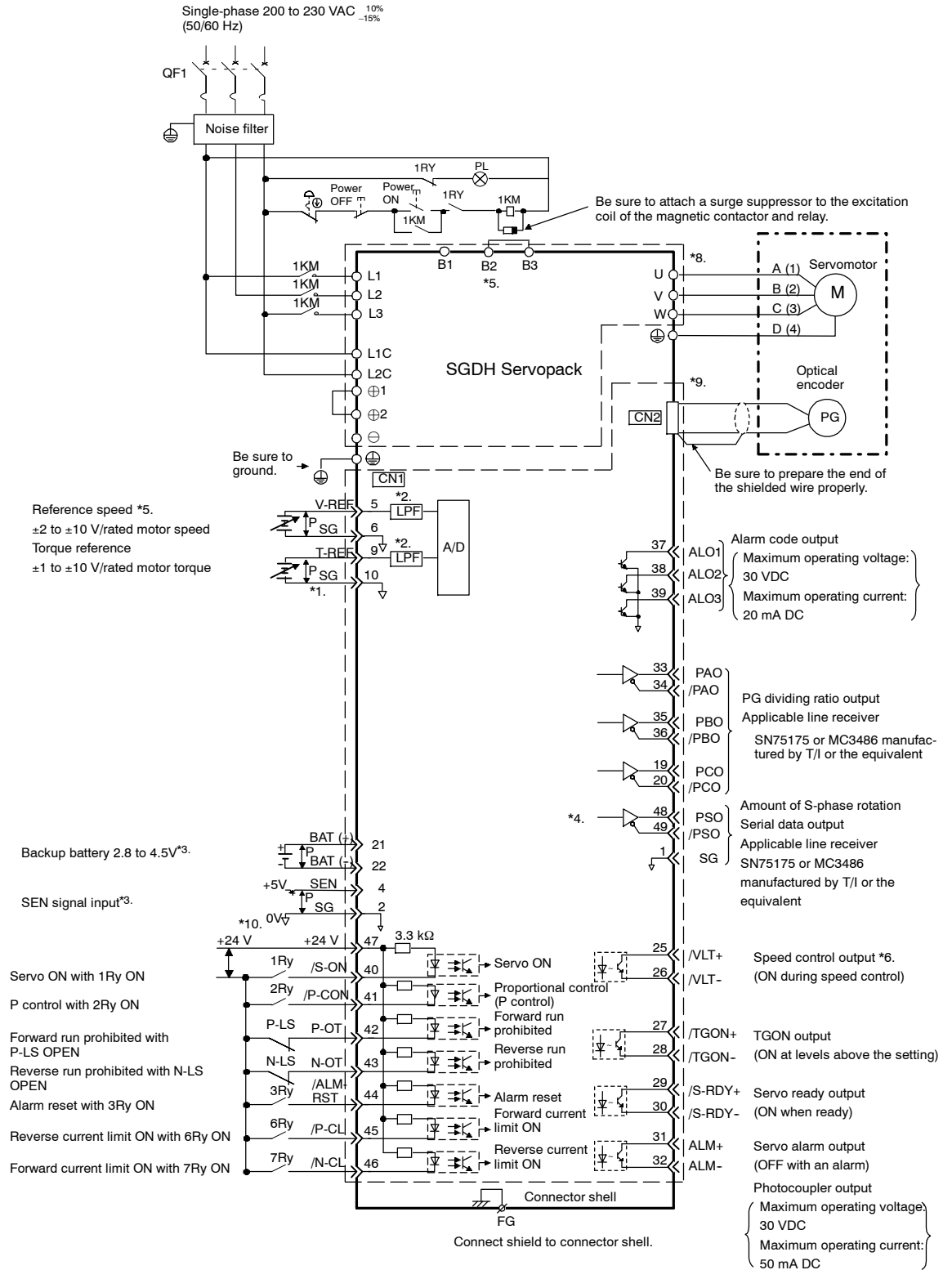

3

3.6.6 Torque Control Mode

- * 1. □P represents twisted-pair wires.
- * 2. The time constant for the primary filter is 47 μ s.
- * 3. Connect when using an absolute encoder.
- * 4. Used only with an absolute encoder.
- * 5. Set via user constant.
- * 6. Set via user constant.
- * 7. Connect an external regenerative resistor between terminals B1 and B2 for Servopacks with a capacity of 6.0 kW or higher. (There is no terminal B3 on these Servopacks.)
- * 8. These circuits are hazardous and therefore, are separated by protecting separator.
- * 9. These circuits are SELV circuits and are separated from all other circuits by double and reinforced insulation.
- * 10. Use a double-insulated 24-VDC power supply.

4

Trial Operation

This chapter describes a two-step trial operation. Be sure to complete step 1 before proceeding to step 2.

4.1 Two-step Trial Operation	4 - 2
4.1.1 Step 1: Trial Operation for Servomotor without Load	4 - 3
4.1.2 Step 2: Trial Operation with the Servomotor Connected to the Machine	4 - 9
4.2 Supplementary Information on Trial Operation	4 - 10
4.2.1 Servomotors with Brakes	4 - 10
4.2.2 Position Control by Host Controller	4 - 11
4.3 Minimum User Constants and Input Signals	4 - 12
4.3.1 User Constants	4 - 12
4.3.2 Input Signals	4 - 13

4.1 Two-step Trial Operation

Make sure that all wiring is completed prior to starting trial operation.

Perform the trial operation in the order given below (step 1 and 2) for your safety. See 4.1.1 and 4.1.2 for more details on the trial operation.

Step 1: Trial Operation for Servomotor without Load

Make sure the Servomotor is wired properly and then turn the shaft prior to connecting the Servomotor to the equipment.

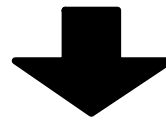
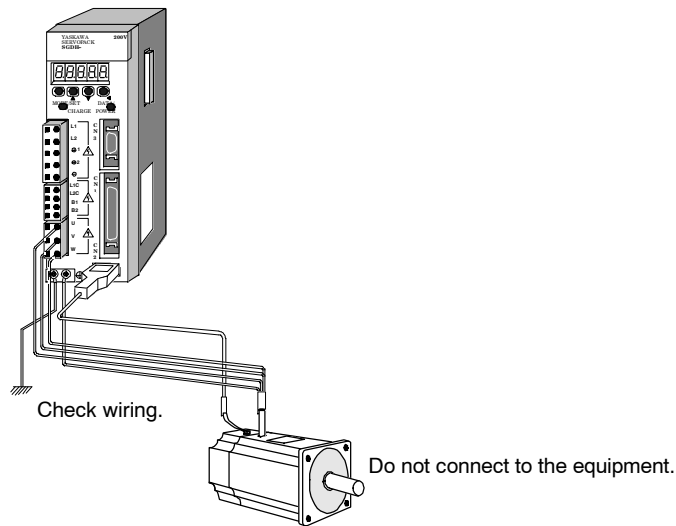

Step 2: Trial Operation with the Equipment and Servomotor Connected

Adjust the Servomotor according to equipment characteristics, connect the Servomotor to the equipment, and perform the trial operation.

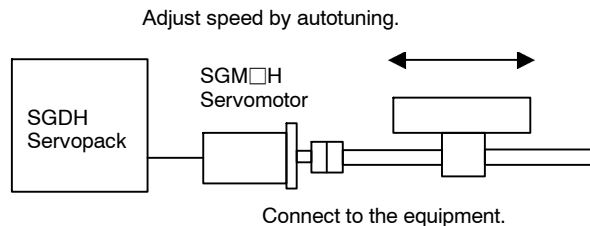

4.1.1 Step 1: Trial Operation for Servomotor without Load

⚠ CAUTION

- Do not operate the Servomotor while it is connected to the equipment.
To prevent accidents, initially perform step 1 where the trial operation is conducted under no-load conditions (with all couplings and belts disconnected).

In step 1, make sure that the Servomotor is wired properly as shown below. Incorrect wiring is generally the reason why Servomotors fail to operate properly during trial operation.

- Check main power supply circuit wiring.
- Check Servomotor wiring.
- Check CN1 I/O signal wiring.

Make sure the host controller and other adjustments are completed as much as possible in step 1 (prior to connecting the Servomotor to equipment).

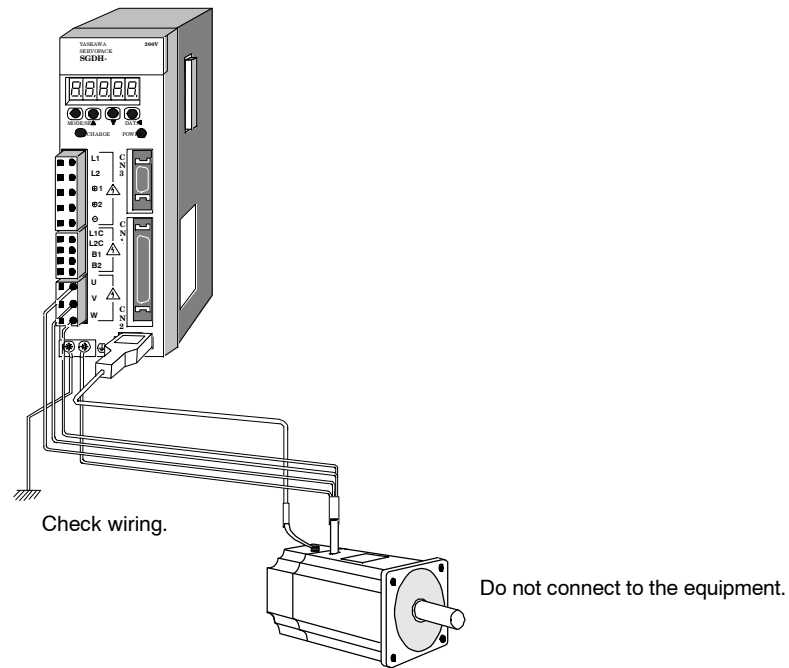

IMPORTANT

Check the items on the following pages in the order given during the Servomotor trial operation.
See 4.2.1 *Servomotors with Brakes* if you are using a Servomotor with brakes.

1. Secure the Servomotor.

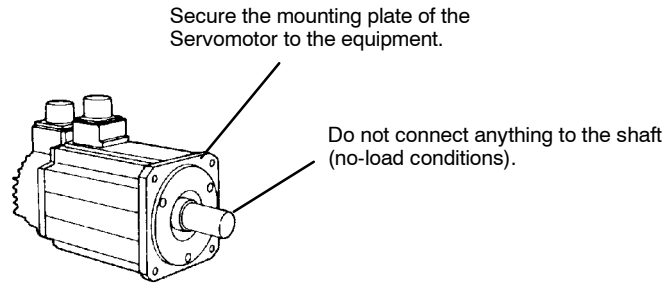

Secure the Servomotor mounting plate to the equipment in order to prevent the Servomotor from moving during operation.

2. Check the wiring.

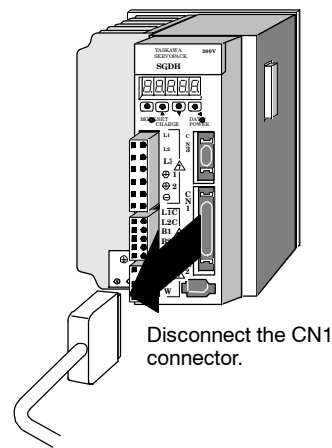

Disconnect the CN1 connector and check Servomotor wiring in the power supply circuit. CN1 I/O signals are not used, so leave the connector disconnected.

3. Turn ON power.

Normal display

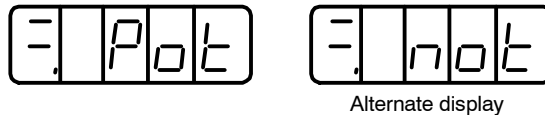

Example of Alarm Display



Turn ON Servopack power. If the Servopack has turned ON normally, the LED display on the front panel of the Servopack will appear as shown above. Power is not supplied to the Servomotor because the servo is OFF.

If an alarm display appears on the LED indicator as shown above, the power supply circuit, Servomotor wiring, or encoder wiring is incorrect. In this case, turn OFF power and take appropriate action. See 7.2 *Troubleshooting*.



If an absolute encoder is used, it must be set up. Refer to 5.7.4 *Absolute Encoder Setup*.

4. Operate with Panel Operator.

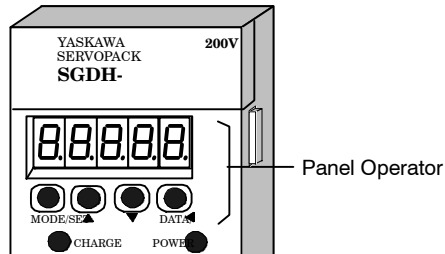

Operate the Servomotor using the Panel Operator. Check to see if the Servomotor runs normally.

See 6.2.2 *Controlling Operation Through the Digital Operator* for more details on the procedure.

5. Connect the signal lines.

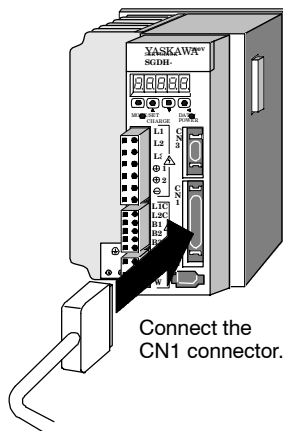

Use the following procedure to connect the CN1 connector.

- a) Turn OFF power.
- b) Connect the CN1 connector.
- c) Turn ON power again.

6. Check the input signals.

Check input signal wiring in Monitor Mode using the Panel Operator. See 6.1.7 *Operation in Monitor Mode* for more details on the procedure.

Turn ON and OFF each signal line to see if the LED monitor bit display on the panel changes as shown below.

Input signal LED display

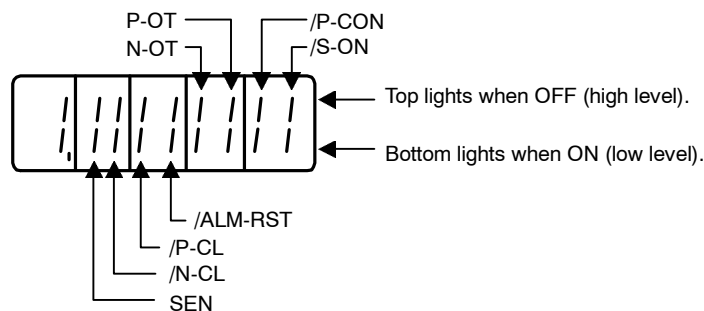

Input Signal Status	LED Display
OFF (high level)	Top LED indicators light.
ON (low level)	Bottom LED indicators light.

IMPORTANT

The Servomotor will not operate properly if the following signal lines are not wired correctly. Short the signal lines if they will not be used. The input signal selections (user constants Pn50A to Pn50D) can be used to eliminate the need for external short circuiting.

Signal Symbol	Connector Pin No.	Description
P-OT	CN1-42	The Servomotor can rotate in the forward direction when this signal line is low (0 V).
N-OT	CN1-43	The Servomotor can rotate in the reverse direction when this signal line is low (0 V).
/S-ON	CN1-40	The Servomotor is turned ON when this signal line is low (0 V). Leave the Servomotor OFF.
+24VIN	CN1-47	Control power supply terminal for sequence signals.



IF an absolute encoder is being used, the servo will not turn ON when the servo ON signal (/S-ON) is input unless the SEN signal is also ON. When the SEN signal is checked in monitor mode, the top of the LED will light because the SEN signal is high when ON.

7. Turn ON the servo.

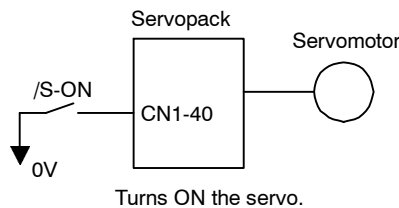

Turn ON the servo using the following procedure.

1. Make sure there are no reference signals input.
 - Set V-REF (CN1-5) and T-REF (CN1-9) to 0 V for speed and torque control.
 - Set PULS (CN1-7) and SIGN (CN1-11) to low for position control.
2. Turn ON the servo ON signal.

Display with the servo ON.

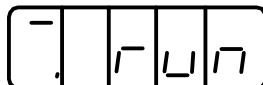

Set /S-ON (CN1-40) to 0 V. If normal, the Servomotor will turn ON and the LED indicator on the front panel will display as shown above. If an alarm display appears, take appropriate action as described in 7.2 *Troubleshooting*.

IMPORTANT

If there is noise in the reference voltage for speed control, the “-” on the left of the 7-segment LED may flash.

■ Operating Using Reference Input

The operating procedure here depends on the user constant settings (control mode selection at memory switch Pn000.1). Use the following procedure for operations with speed and position control.

Operating Procedure in Speed Control Mode: Set Pn000.1 to 0

Standard speed control setting is described here.

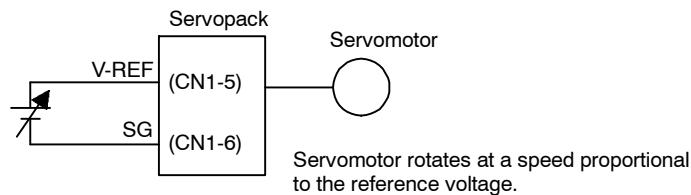

1. Gradually increase the reference speed input (V-REF, CN1-5) voltage. The Servomotor will rotate.
2. Check the following items in Monitor Mode. See 6.1.7 *Operation in Monitor Mode*.

Un000	Actual motor speed
Un001	Reference speed

- Has the reference speed been input?
 - Is the motor speed as designed?
 - Does the reference speed coincide the actual motor speed?
 - Does the Servomotor stop when the speed reference is 0?
3. If the Servomotor rotates at extremely slow speed with 0 V specified for the reference voltage, correct the reference offset value as described in 6.2.3 *Automatic Adjustment of Speed and Torque Reference Offset* or 6.2.4 *Manual Adjustment of Speed and Torque Reference Offset*.
 4. Reset the user constants shown below to change the motor speed or direction of rotation.

Pn300	Sets the reference speed input gain See 5.2.1 <i>Speed Reference</i> .
Pn000.0	Selects the rotation direction. See 5.1.1 <i>Switching Servomotor Rotation Direction</i> .

Operating Procedure in Position Control Mode: Set Pn000.1 to 1

1. Set the user constant Pn200.0 so the reference pulse form is the same as the host controller output form.

Selecting the reference pulse form: See 5.2.2 *Position Reference*.

2. Input a slow speed pulse from the host controller and execute low-speed operation.

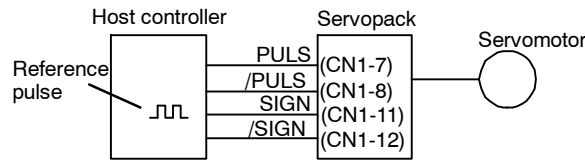

3. Check the following items in Monitor Mode. See 6.1.7 *Operation in Monitor Mode*.

Un000	Actual motor speed
Un007	Reference pulse speed display
Un008	Position offset

- Has the reference pulse been input?
- Is the motor speed as designed?
- Does the reference speed coincide with the actual motor speed?
- Does the Servomotor stop when the speed reference is 0?

4. Reset the user constants shown below to change the motor speed or direction of rotation.

Pn202, Pn203	Electronic gear ratio See 5.2.5 <i>Using the Electronic Gear Function</i> .
Pn000.0	Selects the direction of rotation. See 5.1.1 <i>Switching Servomotor Rotation Direction</i> .

If an alarm occurs or the Servomotor fails to operate during the above operation, CN1 connector wiring is incorrect or user constant settings do not match the host controller specifications. Check the wiring and review the user constant settings, then repeat step 1.



Reference

- List of Alarms: See 7.2.3 *Alarm Display Table*.
- List of User Constants: See *Appendix B List of User Constants*.

4.1.2 Step 2: Trial Operation with the Servomotor Connected to the Machine

⚠ WARNING

- Follow the procedure below for step-2 operation precisely as given.
Malfunctions that occur after the Servomotor is connected to the equipment not only damage the equipment, but may also cause an accident resulting death or injury.

Before proceeding to step 2, repeat step 1 (Servomotor trial operation without a load) until you are fully satisfied that all items including user constants and wiring have been tested completely.

After step 1 has been completed, proceed to step 2 for trial operation with the Servomotor connected to the equipment. The purpose of step 2 is to adjust the Servopack according to equipment characteristics.

- Use autotuning to match the Servopack to equipment characteristics.
- Match the direction of rotation and speed to equipment specifications.
- Check the final control form.

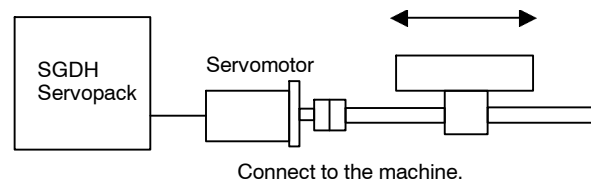

Follow the procedures below to perform the trial operation.

1. Make sure power is OFF.
2. Connect the Servomotor to the equipment.
See *2.1 Servomotors* for more details on connecting the Servomotor.
3. Use autotuning to match the Servopack to equipment characteristics.
See *LEERER MERKER Autotuning*.

4. Operate the Servomotor by reference input.

As in step 1 (Servomotor trial operation with no-load), execute operation by reference input as described in *4.1.1 Step 1: Servomotor Trial Operation*. Tune to match the host controller at this time as well.

5. Set and record user settings.

Set user constants as required and record all settings for use later in maintenance.

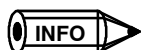

The Servomotor will not be broken in completely during the trial operation. Therefore, let it the system run for a sufficient amount of additional time to ensure that it is properly broken in.

4.2 Supplementary Information on Trial Operation

Always refer to this information before starting trial operation in the following instances:

- 4.2.1 Servomotor with Brakes
- 4.2.2 Position Control by Host Controller

4.2.1 Servomotors with Brakes

Use Servomotors with brakes for vertical shaft applications or when external force is applied to the shaft to prevent the shaft from rotating due to gravity or external force when power is lost.

The Servopack uses the brake interlock output (/BK) signal to control holding brake operation when using Servomotors with brakes.

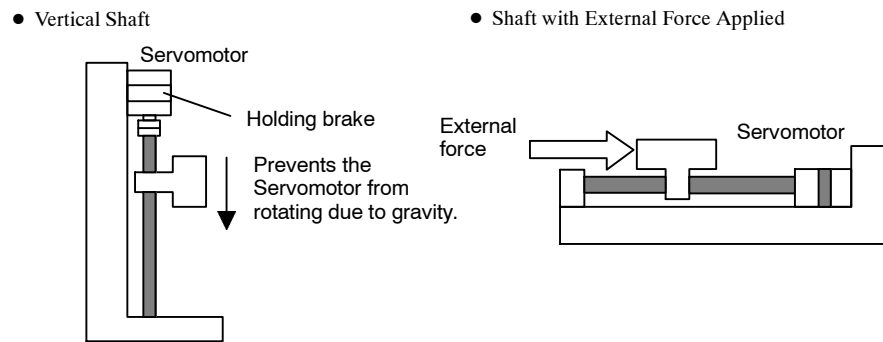

4

IMPORTANT

To prevent faulty operation due to gravity or external force, make sure that the Servomotor and holding brake operate normally with the Servomotor disconnected from the equipment. When both of them operate normally, connect the servomotor to the equipment to start trial operation.

The following figure shows wiring for a Servomotor with brakes. See 5.4.4 *Using the Holding Brake* for details on wiring.

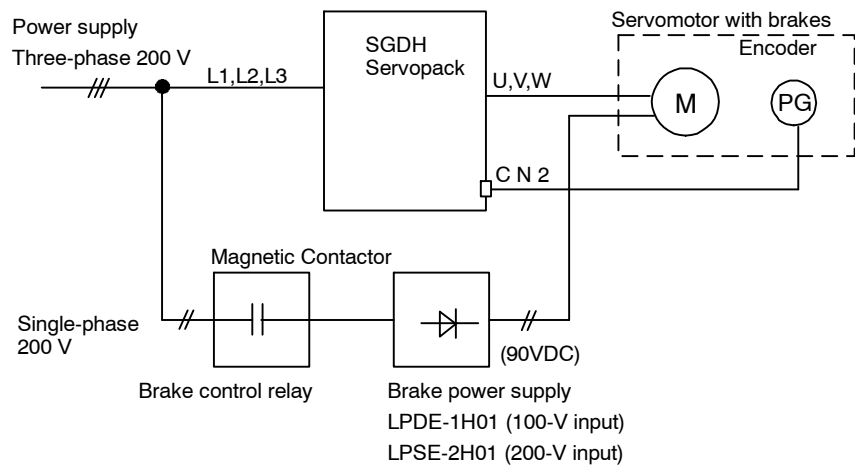

4.2.2 Position Control by Host Controller

If position control from the host controller has not been confirmed, disconnect the Servomotor from the equipment and perform a trial operation, otherwise the Servomotor may run out of control. Check Servomotor operation as described in the following table.

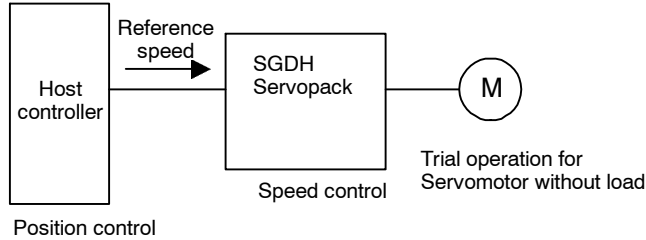

Reference from the Host Controller	Check Item	Check Method	Review Items
JOG Operation (Constant Reference Speed Input from Host Controller)	Motor speed	Check motor speed as follows: <ul style="list-style-type: none"> • Use the speed monitor (Un000) on the Panel Operator. • Run the Servomotor at low speed. Input a reference speed of 60 r/min for example to check to see if the Servomotor makes one revolution per second. 	Check the user constant setting at Pn300 to see if reference speed gain is correct.
Simple Positioning	No. of motor rotations	Input a reference equivalent to one Servomotor rotation and visually check to see if the shaft makes one revolution.	Check the user constant setting at Pn201 to see if the number of dividing pulses is correct.
Overtravel (P-OT and N-OT Used)	Whether the Servomotor stops rotating when P-OT and N-OT signals are input	Check to see if the Servomotor stops when P-OT and N-OT signals are input during continuous Servomotor operation.	Review P-OT and N-OT wiring if the Servomotor does not stop.

4.3 Minimum User Constants and Input Signals

This section describes the minimum user constants and input signals required for trial operation.

4.3.1 User Constants

See 6.1.6 *Operation in User Constant Setting Mode* for more details on setting user constants.

Turn OFF power once after changing any user constant except Pn300. The change will be valid when power is turned ON again.

Basic Parameters

Pn000.1	Function Selection Basic Switches: Control Method Selection	See 5.3.5
----------------	---	-----------

Speed Control

Pn300	Speed Reference Input Gain	See 5.2.1
Pn201	PG Divider	See 5.2.3

Position Control

Pn200.0	Reference Pulse Form	See 5.2.2
Pn202	Electronic Gear Ratio (Numerator)	See 5.2.5
Pn203	Electronic Gear Ratio (Denominator)	See 5.2.5

Changing Servomotor Rotation Direction

The wiring may be incorrect if the specified direction of rotation differs from the actual direction of rotation. Recheck the wiring and correct if necessary. Use the following user constant to reverse the direction of rotation.

Pn000.0	Function Selection Basic Switches: Direction Selection	See 5.1.1
----------------	--	-----------

4.3.2 Input Signals

Refer to the relevant page for details on each input signal.

Input signal selection settings through user constants can be used to eliminate the need for external short circuits.

Signal Name		Pin Number	Description
/S-ON	Servo ON	CN1-40	See 5.5.2 for more details on turning ON and OFF the Servomotor.
P-OT	Forward run prohibited	CN1-42	See 5.1.2 for more details on the overtravel limit switch.
N-OT	Reverse run prohibited	CN1-43	

5

User Constant Settings and Functions

This chapter describes the procedure for setting and applying user constants.

5.1 Settings According to Device	
Characteristics	5 -4
5.1.1 Switching Servomotor Rotation Direction	5 -4
5.1.2 Setting the Overtravel Limit Function	5 -5
5.1.3 Limiting Torques	5 -9
5.2 Settings According to Host Controller	5 -13
5.2.1 Speed Reference	5 -13
5.2.2 Position Reference	5 -15
5.2.3 Using the Encoder Signal Output	5 -21
5.2.4 Sequence I/O Signals	5 -24
5.2.5 Using the Electronic Gear Function	5 -27
5.2.6 Contact Input Speed Control	5 -31
5.2.7 Using Torque Control	5 -36
5.2.8 Torque Feed-forward Function	5 -42
5.2.9 Speed Feed-forward Function	5 -43
5.2.10 Torque Limiting by Analog Voltage Reference, Function 1	5 -44
5.2.11 Torque Limiting by Analog Voltage Reference, Function 2	5 -45
5.2.12 Reference Pulse Inhibit Function (INHIBIT)	5 -47
5.3 Setting Up the Servopack	5 -48
5.3.1 User Constants	5 -48
5.3.2 JOG Speed	5 -49
5.3.3 Input Circuit Signal Allocation	5 -49
5.3.4 Output Circuit Signal Allocation	5 -55

5.3.5	Control Mode Selection	5 -58
5.4	Setting Stop Functions	5 -60
5.4.1	Adjusting Offset	5 -60
5.4.2	Using the Dynamic Brake	5 -61
5.4.3	Using the Zero Clamp Function	5 -62
5.4.4	Using the Holding Brake	5 -64
5.5	Forming a Protective Sequence	5 -68
5.5.1	Using Servo Alarm and Alarm Code Outputs	5 -68
5.5.2	Using the Servo ON Input Signal	5 -70
5.5.3	Using the Positioning Completed Output Signal ..	5 -71
5.5.4	Speed Coincidence Output	5 -72
5.5.5	Using the Running Output Signal	5 -74
5.5.6	Using the Servo Ready Output Signal	5 -75
5.5.7	Using the Warning Output Signal	5 -76
5.5.8	Using the Near Output Signal	5 -77
5.5.9	Handling Power Loss	5 -79
5.6	Selecting a Regenerative Resistor	5 -80
5.6.1	External Regenerative Resistors	5 -81
5.6.2	Calculating the Required Capacity of Regenerative Resistors	5 -84
5.7	Absolute Encoders	5 -92
5.7.1	Interface Circuit	5 -93
5.7.2	Selecting an Absolute Encoder	5 -94
5.7.3	Handling Batteries	5 -94
5.7.4	Absolute Encoder Setup	5 -95
5.7.5	Absolute Encoder Reception Sequence	5 -97
5.7.6	Multiturn Limit Setting	5 -101
5.8	Special Wiring	5 -105
5.8.1	Wiring Precautions	5 -105
5.8.2	Wiring for Noise Control	5 -109
5.8.3	Using More Than One Servodrive	5 -113
5.8.4	Extending Encoder Cables	5 -114
5.8.5	400-V Power Supply Voltage	5 -116
5.8.6	DC Reactor for Harmonic Suppression	5 -117

■ Before Reading this Chapter

This chapter describes the use of each CN1 connector I/O signals in the SGDHServopack as well as the procedure for setting the related user constants for the intended purposes.

The following sections can be used as references for this chapter.

- List of CN1 I/O signals: See 3.4.3 *I/O Signal Names and Functions*.
- CN1 I/O signal terminal layout: See 3.4.2 *List of CN1 Terminals*.
- List of user constants: Appendix *Appendix LEERER MERKER List of User Constants*.
- User constant setting procedure: 6.1.6 *Operation in User Constant Setting Mode*

The CN1 connector is used to exchange signals with the host controller and external circuits.

■ User Constant Configurations

User constants are comprised of the types shown in the following table. See *Appendix B List of User Constants*.

Type	User Constant No.	Description
Function Selection Constants	Pn000 to Pn003	Select basic and application functions such as the type of control or the stop mode used when an alarm occurs.
Servo Gain and Other Constants	Pn100 to Pn123	Set numerical values such as speed and position loop gains.
Position Control Constants	Pn200 to Pn208	Set position control parameters such as the reference pulse input form and gear ratio.
Speed Control Constants	Pn300 to Pn308	Set speed control parameters such as speed reference input gain and soft start deceleration time.
Torque Control Constants	Pn400 to Pn409	Set torque control parameters such as the torque reference input gain and forward/reverse torque limits.
Sequence Constants	Pn500 to Pn512	Set output conditions for all sequence signals and changes I/O signal selections and allocations.
Others	Pn600 to Pn601	Specify the capacity for an external regenerative resistor and reserved constants.
Auxiliary Function Execution	Fn000 to Fn014	Execute auxiliary functions such as JOG Mode operation.
Monitor Modes	Un000 to Un00D	Enable speed and torque reference monitoring, as well as monitoring to check whether I/O signals are ON or OFF.

5.1 Settings According to Device Characteristics

This section describes the procedure for setting user constants according to the dimensions and performance of the equipment used.

5.1.1 Switching Servomotor Rotation Direction

The Servopack has a Reverse Rotation Mode that reverses the direction of Servomotor rotation without rewiring. Forward rotation in the standard setting is defined as counterclockwise as viewed from the load.

With the Reverse Rotation Mode, the direction of Servomotor rotation can be reversed without changing other items. The direction (+, -) of shaft motion is reversed.

	Standard Setting	Reverse Rotation Mode
Forward Reference	<p>Encoder output from Servopack PAO (phase A) PBO (phase B)</p>	<p>Encoder output from Servopack PAO (phase A) PBO (phase B)</p>
Reverse Reference	<p>Encoder output from Servopack PAO (phase A) PBO (phase B)</p>	<p>Encoder output from Servopack PAO (phase A) PBO (phase B)</p>

■ Setting Reverse Rotation Mode

Use user constant Pn000.0.

Pn000.0	Direction Selection	Factory Setting:	Speed/Torque Control, Position Control
		0	

Use the following settings to select the direction of Servomotor rotation.

Setting	Description
0	Forward rotation is defined as counterclockwise (CCW) rotation as viewed from the load. (Standard setting)
1	Forward rotation is defined as clockwise (CW) rotation as viewed from the load. (Reverse Rotation Mode)

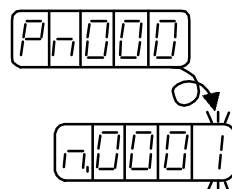

5

5.1.2 Setting the Overtravel Limit Function

The overtravel limit function forces movable equipment parts to stop if they exceed the allowable range of motion.

■ Using the Overtravel Function

To use the overtravel function, connect the overtravel limit switch input signal terminals shown below to the correct pins of the Servopack CN1 connector.

→ Input P-OT CN1-42	Forward Run Prohibited (Forward Overtravel)	Speed/Torque Control, Position Control
→ Input N-OT CN1-43	Reverse Run Prohibited (Reverse Overtravel)	Speed/Torque Control, Position Control

Connect limit switches as shown below to prevent damage to the devices during linear motion.

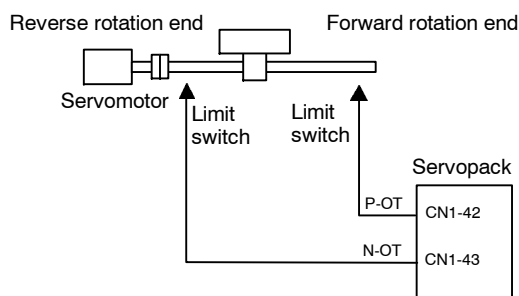

Drive status with an input signal ON or OFF is shown in the following table.

P-OT	CN1-42 at low level when ON	Forward rotation allowed. Normal operation status.
	CN1-42 at high level when OFF	Forward run prohibited (reverse rotation allowed).
N-OT	CN1-43 at low level when ON	Reverse rotation allowed. Normal operation status.
	CN1-43 at high level when OFF	Reverse run prohibited (forward rotation allowed).

■ Enabling/Disabling Input Signals

Set the following user constants to specify whether input signals are used for overtravel or not. The factory setting is “used.”

Pn50A.3	P-OT Signal Mapping (Forward Run Prohibit Input Signal)	Factory Setting: 2	Speed/Torque Control, Position Control
Pn50B.0	N-OT Signal Mapping (Reverse Run Prohibit Input Signal)	Factory Setting: 3	Speed/Torque Control, Position Control

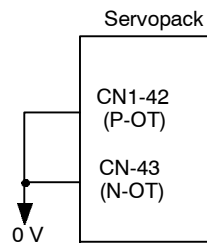

The short-circuit wiring shown in the figure can be omitted when P-OT and N-OT are not used.

User Constant	Setting	Item
Pn50A.3	2 (Factory setting)	Uses the P-OT input signal for prohibiting forward rotation. (Forward rotation is prohibited when CN1-42 is open and is allowed when CN1-42 is at 0 V.)
	8	Does not use the P-OT input signal for prohibiting forward rotation. (Forward rotation is always allowed and has the same effect as shorting CN1-42 to 0 V.)
Pn50B.0	3 (Factory setting)	Uses the N-OT input signal for prohibiting reverse rotation. (Reverse rotation is prohibited when CN1-43 is open and is allowed when CN1-43 is at 0 V.)
	8	Does not use the N-OT input signal for prohibiting reverse rotation. (Reverse rotation is always allowed and has the same effect as shorting CN1-43 to 0 V.)

■ Servomotor Stop Mode for P-OT and N-OT Input Signals

Set the following user constants to specify the Servomotor Stop Mode when P-OT and N-OT input signals are used.

Specify the Servomotor Stop Mode when either of the following signals is input during Servomotor operation.

- Forward run prohibited input (P-OT,CN1-42)
- Reverse run prohibited input (N-OT,CN1-43)

5

Pn001.1	Overtravel Stop Mode	Factory Setting: 0	Speed/Torque Control, Position Control
----------------	-----------------------------	-------------------------------------	---

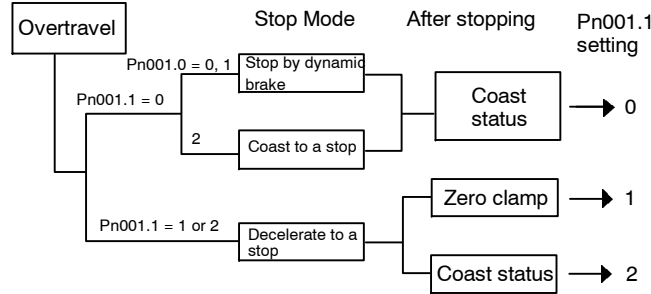

For torque control, the servomotor will be placed in coast status after either decelerating or coasting to a stop (according to the stop mode set in Pn001.0), regardless of the setting of Pn001.1.

User Constant	Setting	Item
Pn001.1	0	Stops the Servomotor the same way as turning the servo OFF (according to Pn001.0).
	1	Decelerates the Servomotor to a stop at the preset torque, and then locks the Servomotor in Zero Clamp Mode. Torque setting: Pn406 emergency stop torque
	2	Decelerates the Servomotor to a stop at the preset torque, and puts the Servomotor in coast status. Torque setting: Pn406 emergency stop torque

Pn406 specifies the stop torque applied for overtravel when the input signal for prohibiting forward or reverse rotation is used.

The torque limit is specified as a percentage of rated torque.

Pn406	Emergency Stop Torque	Unit: %	Setting Range: 0 to Max. Torque	Factory Setting: 800	Valid when Pn001.1 is 1 or 2
--------------	------------------------------	--------------------------	--	---------------------------------------	-------------------------------------

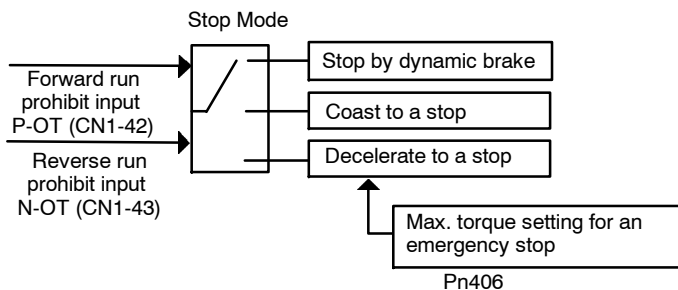

■ Servo OFF Stop Mode Selection

The SGDH Servopack turns OFF under the following conditions:

- Servo ON input signal (/S-ON, CN1-40) is turned OFF.
- Servo alarm occurs.
- Power is turned OFF.

Specify the Stop Mode if any of these occurs during operation.

Pn001.0	Servo OFF or Alarm Stop Mode	Factory Setting: 0	-
----------------	-------------------------------------	-------------------------------------	---

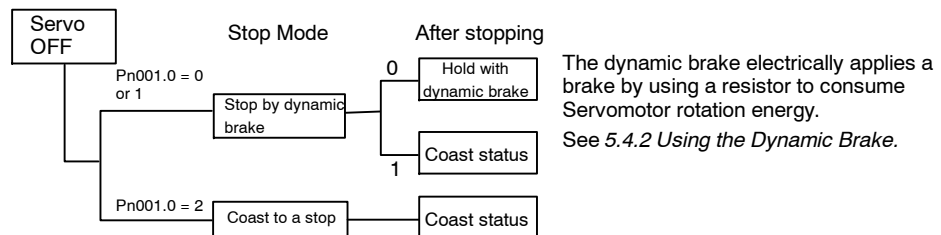

User Constant	Setting	Item
Pn001.0	0 (Factory setting)	Uses the dynamic brake to stop the Servomotor, and maintains dynamic brake status after stopping.
	1	Uses the dynamic brake to stop the Servomotor, and cancels dynamic brake status after stopping to go into coast status.
	2	Coasts the Servomotor to a stop. The Servomotor is turned OFF and stops due to equipment friction.

Note If the Servomotor is stopped or rotating at extremely low speed when the items above are set at 0 (dynamic brake status after stopping with the dynamic brake), then braking power is not generated and the Servomotor will stop the same as in coast status.

5

5.1.3 Limiting Torques

The SGDh Servopack limits torques as follows:

- Level 1: Limits maximum output torque to protect the equipment or workpiece.
- Level 2: Limits torque after the Servomotor moves the equipment to a specified position (internal torque limit).
- Level 3: Always limits output torque rather than speed.
- Level 4: Switches between speed and torque limit.

Application of levels 1 and 2 in the torque limit function are described below.

■ Setting Level 1: Internal Torque Limits

Maximum torque is limited to the values set in the following user constants.

Pn402	Forward Torque Limit	Unit: %	Setting Range: 0 to 800	Factory Setting: 800	Speed/Torque Control, Position Control
Pn403	Reverse Torque Limit	Unit: %	Setting Range: 0 to 800	Factory Setting: 800	Speed/Torque Control, Position Control

This user constant sets the maximum torque limits for forward and reverse rotation.

Use this user constant when torque must be limited due to equipment conditions.

The torque limit function always monitors torque and outputs the signals below when the limit is reached.

The following signals are output by the torque limit function.

<ul style="list-style-type: none"> • /CLT • Monitor Mode (Un006)
<p>Condition that outputs a /CLT signal:</p> <p>Pn50F.0 allocates an output terminal from SO1 to SO3.</p>

The torque limits are specified as a percentage of the rated torque.



If torque limit is set higher than the maximum torque of the Servomotor, the maximum torque of the Servomotor is the limit.

Application Example: Equipment Protection

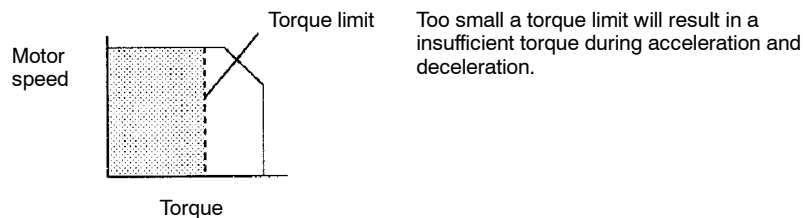

Using /CLT Signal

The following section describes the use of the contact output signal /CLT as a torque limit output signal.

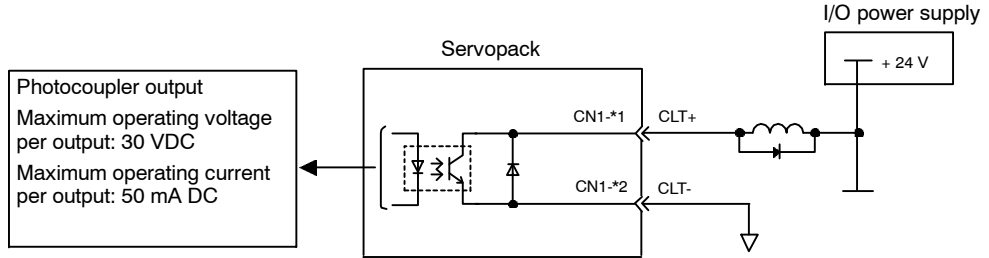

Output → /CLT CN1-*1	Torque Limit Output	Speed/Torque Control, Position Control
----------------------	----------------------------	---

This signal indicates whether Servomotor output torque (current) is being limited.

ON Status	The circuit between CN1-*1 and *2 is closed. CN1-*1 is at low level.	Servomotor output torque is being limited. (Internal torque reference is greater than the limit setting.)
OFF Status	The circuit between CN1-*1 and *2 is closed. CN1-*1 is at low level.	Servomotor output torque is not being limited. (Internal torque reference is less than the limit setting.)

Settings: Pn402 (Forward Torque Limit)

Pn403 (Reverse Torque Limit)

Pn404 (Forward External Torque Limit): /P-CL input only

Pn405 (Reverse External Torque Limit): /N-CL input only

When the /CLT signal is used, the following user constant must be used to select the output signal.

Pn50F	Output Signal Selections 2	Factory Setting: 0000	Speed/Torque Control, Position Control
--------------	-----------------------------------	--	---

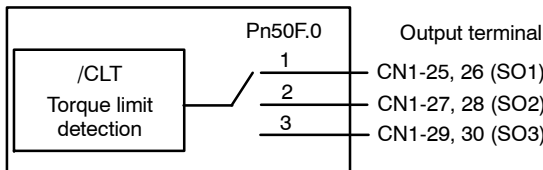

Use the following table to select which terminal will output the /CLT signal.

User Constant	Setting	Output Terminal (CN1-)	
		*1	*2
Pn50F.0	0	-	-
	1	25	26
	2	27	28
	3	29	30

5

Note Multiple signals allocated to the same output circuit are output using OR logic. Set other output signals to a value other than that allocated to the /CLT signal in order to use just the /CLT output signal. See 5.3.4 *Output Circuit Signal Allocation*.

■ Setting Level 2: External Torque Limit

A contact input signal is used to enable the torque (current) limits previously set in user constants. Torque limits can be set separately for forward and reverse rotation.

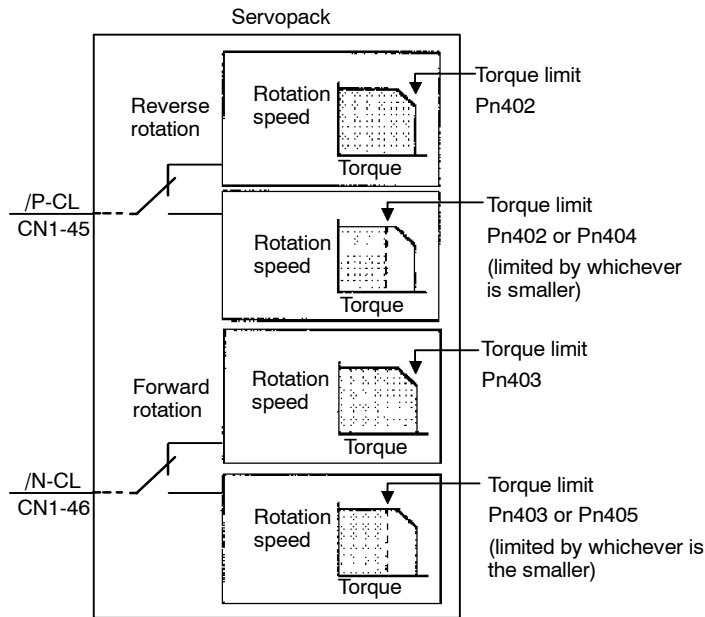

→ Input /P-CL CN1-45	Forward External Torque Limit Input	Speed/Torque Control, Position Control
→ Output /N-CL CN1-46	Reverse External Torque Limit Input	Speed/Torque Control, Position Control

This is the external torque (current) limit input for forward and reverse rotation.

Check input signal allocation status when using this function. (See 5.3.3 *Input Circuit Signal Allocation*.) Factory settings are given in the following table.

/P-CL	CN1-45 at low level when ON	Use forward torque limit.	Limit: Pn404
	CN1-45 at high level when OFF	Do not use forward torque limit. Normal operation.	-
/N-CL	CN1-46 at low level when ON	Use reverse torque limit.	Limit: Pn405
	CN1-46 at high level when OFF	Do not use reverse torque limit. Normal operation.	-

The following output signals and monitor methods are used when torque is being limited.

<ul style="list-style-type: none"> • /CLT • Monitor Mode • Un005: Nos. 6 and 7 (With factory settings) (Refer to 6.1.7 <i>Operation in Monitor Mode.</i>) • Un006: Depending on output signal allocation conditions.
<p>Condition that outputs a /CLT signal:</p> <p>Pn50F.0 is allocated to an output terminal from SO1 to SO3.</p>

Application Examples:

- Forced stop.
- Robot holding a workpiece.

Pn404	Forward External Torque Limit	Unit: %	Setting Range: 0 to 800	Factory Setting: 100	Speed/Torque Control, Position Control
Pn405	Reverse External Torque Limit	Unit: %	Setting Range: 0 to 800	Factory Setting: 100	Speed/Torque Control, Position Control

Set the torque limits when the torque is limited by an external contact input.

/P-CL (CN1-45) Input	Pn404 torque limit applied.
/N-CL (CN1-46) Input	Pn405 torque limit applied.

See 5.2.10 *Using Torque Limiting by Analog Voltage Reference.*

Using /P-CL and /N-CL Signals

The procedure for using /P-CL and /N-CL as torque limit input signals is illustrated below.

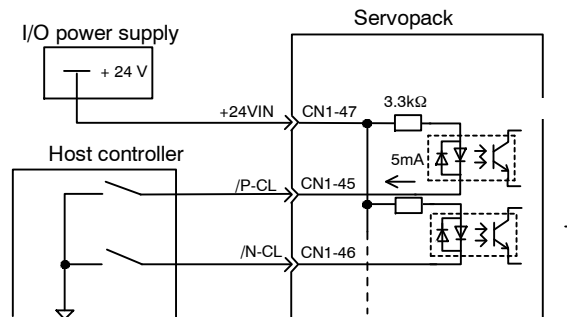

5

5.2 Settings According to Host Controller

This section describes the procedure for connecting a Σ -II Series Servo to a host controller, including the procedure for setting related user constants.

5.2.1 Speed Reference

Input the speed reference using the following input signal speed reference input. Since this signal has various uses, set the optimum reference input for the system created.

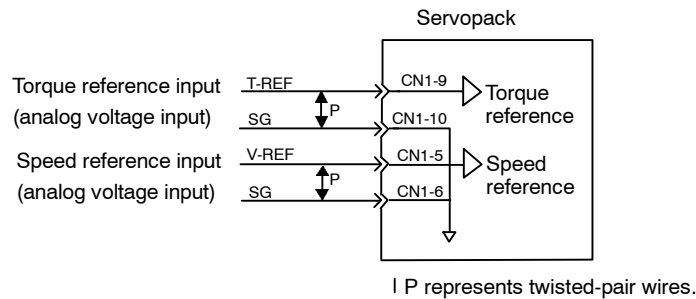

→ Input V-REF CN1-5	Speed Reference Input	Speed Control
→ Input SG CN1-6	Signal Ground	Speed Control

The above inputs are used for speed control (analog reference). (Pn000.1 = 0, 4, 7, 9, or A)

Always wire for normal speed control.

The motor speed is controlled in proportion to the input voltage between V-REF and SG.

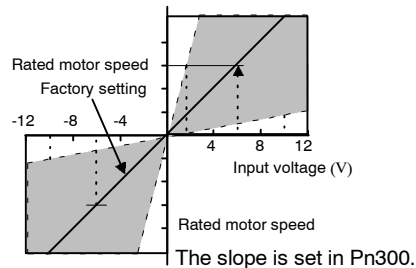

■ Setting Examples

Pn300 = 600: This setting means that 6 V is equivalent to the rated motor speed.

◀EXAMPLE▶

Speed Reference Input	Rotation Direction	Motor Speed	SGMAH Servomotor
+6 V	Forward rotation	Rated motor speed	3000 r/min
+1 V	Forward rotation	(1/6) rated motor speed	500 r/min
-3 V	Reverse rotation	(1/2) rated motor speed	1500 r/min

User constant Pn300 can be used to change the voltage input range.

Input Circuit Example

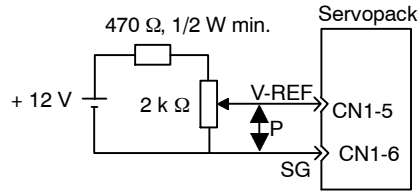

- Always use twisted-pair cable for noise control.

Recommended variable resistor: Model 25HP-10B manufactured by Sakae Tsushin Kogyo Co., Ltd.

Connect V-REF and SG to the speed reference output terminals on the host controller when using a host controller, such as a programmable controller, for position control.

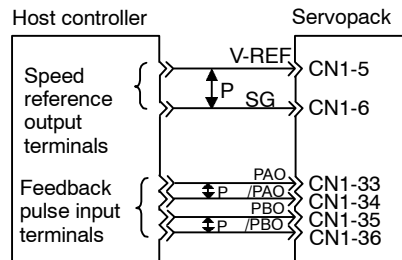

↑ P: Indicates twisted-pair wires.

Adjust Pn300 according to output voltage specifications.

Adjust the speed reference input gain at the following user constant.

Pn300	Speed Reference Input Gain	Unit: 0.01V/rated motor speed	Setting Range: 150 to 3000	Speed Control

Set the voltage range for the speed reference input V-REF at CN1-5 according to host controller and external circuit output form.

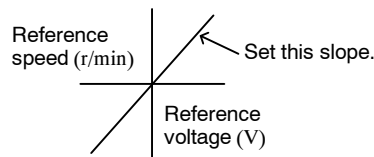

The factory setting is adjusted so that a 6-V input is equivalent to the rated motor speed of all applicable Servomotors.



The maximum allowable voltage to the speed reference input (between CN1-5 and 6) is ± 12 VDC.

5

Using the /P-CON Signal

→ Input /P-CON CN1-41

Proportional Control Reference

Speed Control,
Position Control

The /P-CON input signal switches the Speed Control Mode from PI (proportional-integral) to P (proportional) control in order to reduce Servomotor rotation and minute vibrations due to speed reference input drift. The use of this signal will vary with applications because Servomotor rigidity (holding force) drops when the Servomotor is stopped.

5.2.2 Position Reference

The reference pulse, reference code, and clear inputs are used for the position reference. Since this signal can be used in different ways; set the optimum reference input for the system created.

■ Reference by Pulse Input

Positioning is controlled by inputting a move reference pulse.

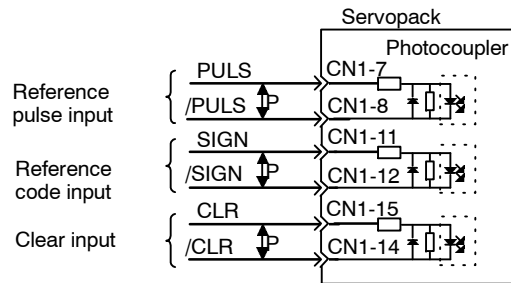

↕ P: Indicates twisted-pair wires.

Any of the following forms can be used for the position reference:

- Line-driver output
- +12-V open-collector output
- +5-V open-collector output

Connection Example 1: Line-driver Output

Applicable line driver: SN75174 manufactured by Texas Instruments Inc., MC3487 or equivalent

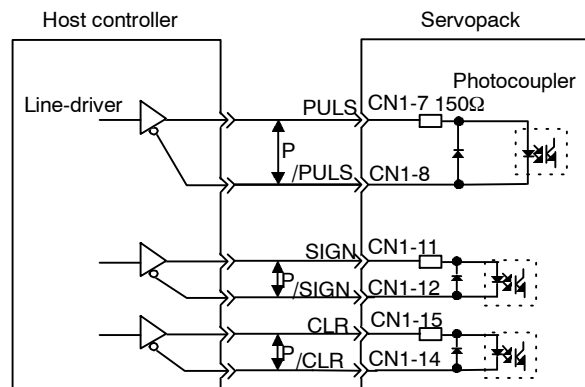

Connection Example 2: Open-collector Output

Set limiting resistor R1 so that input current, i , falls within the following range:

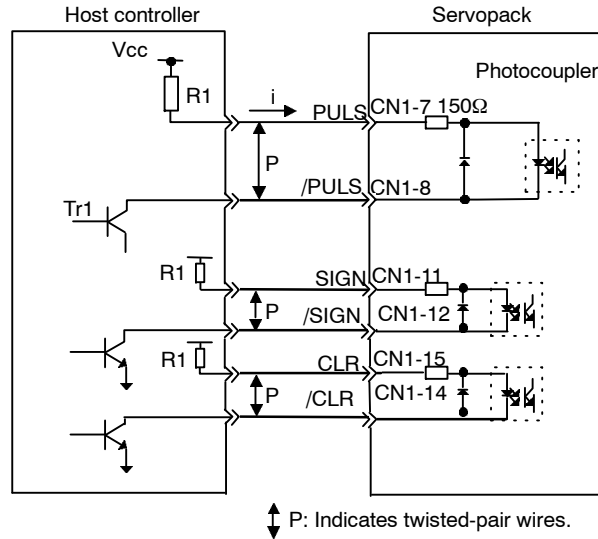

Input current i : 7 to 15 mA

EXAMPLE

- With a V_{cc} of +12 V: $R1 = 1\text{ k}\Omega$
- When V_{cc} is +5 V: $R1 = 180\Omega$

Note The following table shows the signal logic for an open-collector output.

When Tr1 is ON	Equivalent to high-level input
When Tr1 is OFF	Equivalent to low-level input

This circuit uses the 12-V power supply built into the Servopack. Input is not insulated.

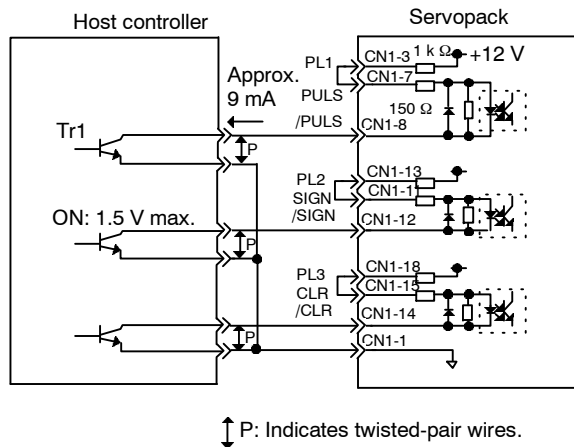

IMPORTANT

The noise margin of the input signal will decrease if the reference pulse is given using an open-collector output. Set user constant Pn200.3 to 1 if the position drifts due to noise.

■ Selecting a Reference Pulse Form

Use the following user constants to select the reference pulse form used.

→ Input PULS CN1-7	Reference Pulse Input	Position Control
→ Input /PULS CN1-8	Reference Pulse Input	Position Control
→ Input SIGN CN1-11	Reference Code Input	Position Control
→ Input /SIGN CN1-12	Reference Code Input	Position Control

The Servomotor only rotates at an angle proportional to the input pulse.

Pn200.0	Reference Pulse Form	Factory Setting: 0	Position Control
----------------	-----------------------------	-------------------------------------	-------------------------

Set reference pulse form input to the Servopack from the host controller.

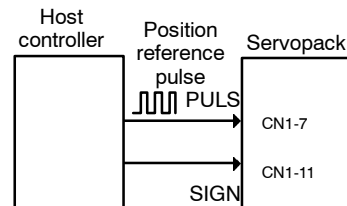

Since the reference pulse form can be selected from among those listed below, set one according to host controller specifications.

User Constant Pn200.0	Reference Pulse Form	Input Pulse Multiplier	Logic	Forward Rotation Reference	Reverse Rotation Reference
0	Sign + pulse train	-	Positive logic	PULS (CN1-7) High SIGN (CN1-11)	PULS (CN1-7) Low SIGN (CN1-11)
1	CW pulse + CCW pulse	-		PULS (CN1-7) Low SIGN (CN1-11)	PULS (CN1-7) Low SIGN (CN1-11)
2	Two-phase pulse train with 90° phase differential	×1		90° PULS (CN1-7) High SIGN (CN1-11) High	90° PULS (CN1-7) High SIGN (CN1-11) High
3		×2			
4		×4			
5	Sign + pulse train	-	Negative logic	PULS (CN1-7) Low SIGN (CN1-11)	PULS (CN1-7) High SIGN (CN1-11)
6	CW pulse + CCW pulse	-		PULS (CN1-7) High SIGN (CN1-11)	PULS (CN1-7) High SIGN (CN1-11)
7	Two-phase pulse train with 90° phase differential	×1		90° PULS (CN1-7) High SIGN (CN1-11) High	90° PULS (CN1-7) High SIGN (CN1-11) High
8		×2			
9		×4			

Input Pulse Multiplier

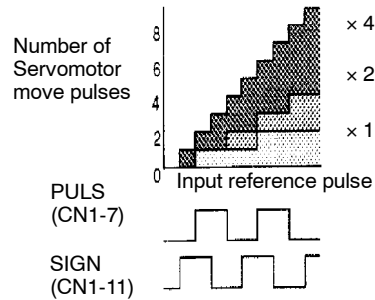

The input pulse multiplier function can be used if the reference form is a two-phase pulse train with a 90° phase differential. The electronic gear function can also be used to convert input pulses.

Example of I/O Signal Generation Timing

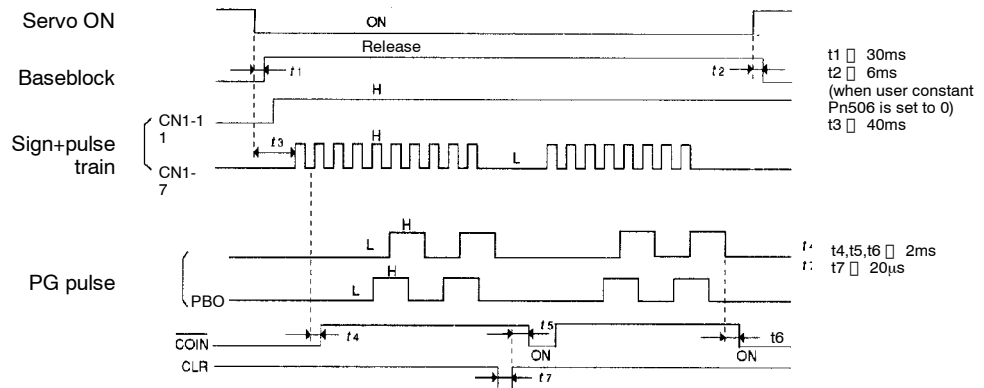

Note 1. The interval from the time the servo ON signal is turned ON until a reference pulse is input must be at least 40 ms. Otherwise the reference pulse may not be input.

2. The error counter clear signal must be ON for at least 20 μs .

5

Reference Pulse Input Signal Timing

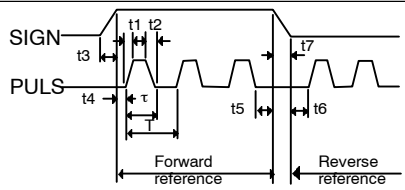
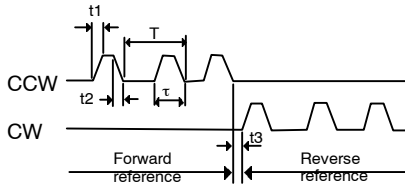
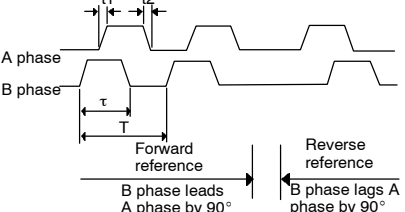
Reference Pulse Form	Electrical Specifications	Remarks
Sign + pulse train input (SIGN + PULS signal) Maximum reference frequency: 500 kpps (200-kpps open-collector output)		Sign (SIGN) H = Forward reference L = Reverse reference
CW pulse and CCW pulse Maximum reference frequency: 500 kpps (200-kpps open-collector output)		-
Two-phase pulse train with 90° phase differential (A phase + B phase) Maximum reference frequency × 1: 500 kpps (200-kpps open-collector output) ×2: 400 kpps ×4: 200 kpps		User constant Pn200.0 is used to switch the input pulse multiplier mode.

■ Error Counter Clear Input

The procedure for clearing the error counter is described below.

→ Input CLR CN1-15	Clear Input	Position Control
→ Input /CLR CN1-14	Clear Input	Position Control

The following occur when the CLR signal is set to high level.

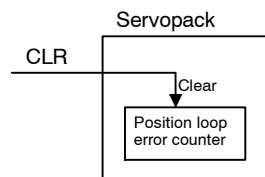

- The error counter inside the Servopack is set to 0.
- Position loop control is prohibited.

Use this signal to clear the error counter from the host controller or select the following clear operation through user constant Pn200.1.

Pn200.1	Error Counter Clear Signal Form	Factory Setting:	Position Control
		0	

Select the pulse form for the error counter clear signal CLR (CN1-15).

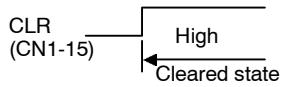
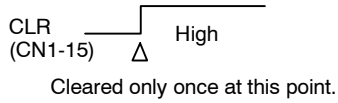
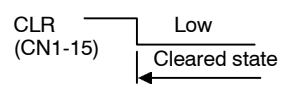
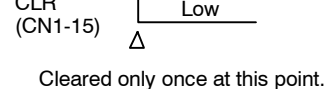
Pn200.1 Setting	Description	Clear Timing
0	<p>Clears the error counter when the CLR signal goes high.</p> <p>Error pulses do not accumulate as long as the signal remains high.</p>	
1	<p>Clears the error counter on the rising edge of the CLR signal.</p> <p>Clears the error counter only once on the rising edge of the CLR signal.</p>	
2	<p>Clears the error counter when the CLR signal goes low.</p> <p>Error pulses do not accumulate as long as the signal remains low.</p>	
3	<p>Clears the error counter on the falling edge of the CLR signal.</p> <p>Clears the error counter only once on the falling edge of the CLR signal.</p>	

5.2.3 Using the Encoder Signal Output

Encoder output signals divided inside the Servopack can be output externally. These signals can be used to form a position control loop in the host controller.

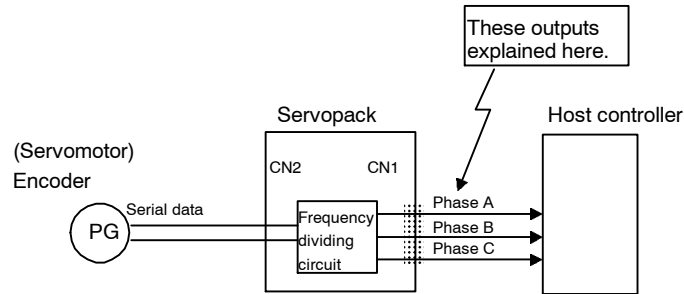

The output circuit is for line-driver output. Connect each signal line according to the following circuit diagram.

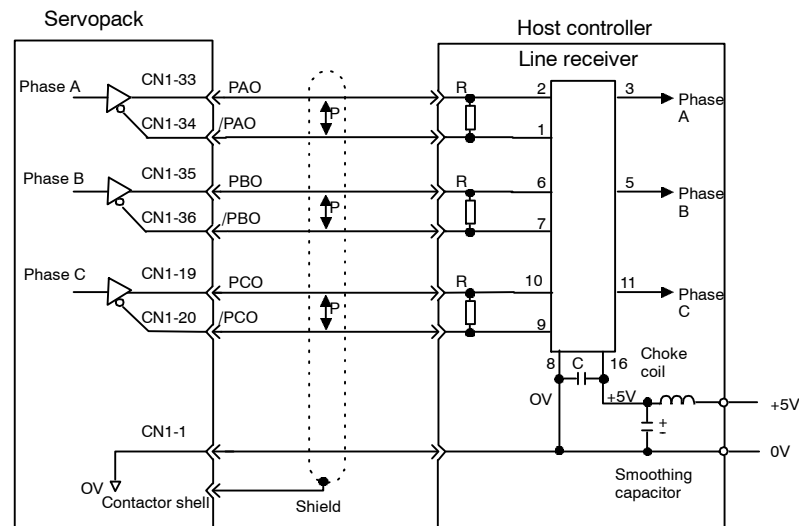

↕ P: Indicates twisted-pair wires.

Applicable line receiver: SN75175 manufactured by Texas Instruments Inc., MC3486 or the equivalent.

R (terminator): 220 to 470 Ω

C (decoupling capacitor): 0.1 μF



◆ Dividing

Dividing means converting an input pulse train from the encoder mounted on the Servomotor according to the preset pulse density and outputting the converted pulse. The units are pulses per revolution.

I/O Signals

I/O signals are described below.

Output → PAO CN1-33	Encoder Output Phase A	Speed/Torque Control, Position Control
Output → /PAO CN1-34	Encoder Output Phase /A	Speed/Torque Control, Position Control
Output → PBO CN1-35	Encoder Output Phase B	Speed/Torque Control, Position Control
Output → /PBO CN1-36	Encoder Output Phase /B	Speed/Torque Control, Position Control
Output → PCO CN1-19	Encoder Output Phase C	Speed/Torque Control, Position Control
Output → /PCO CN1-20	Encoder Output Phase /C	Speed/Torque Control, Position Control

Divided encoder signals are output.

Always connect these signal terminals when a position loop is formed in the host controller for position control.

Set a dividing ratio at the following user constant.

PG Dividing Ratio	Pn201
--------------------------	-------

The dividing ratio setting is not related to the gear ratio setting (Pn202 and 203) for the Servopack electronic gear function during position control.

Output Phase Form

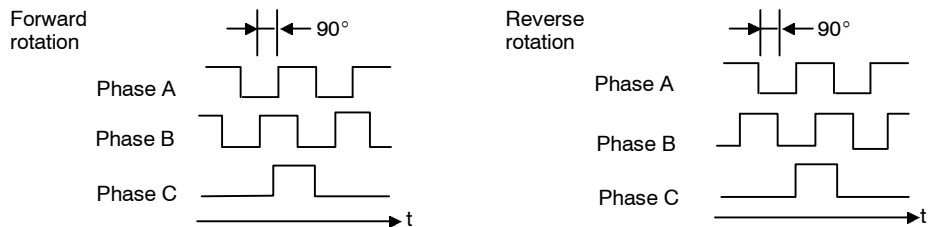

→ Input SEN CN1-4	SEN Signal Input	Speed/Torque Control
→ Input SG CN1-2	Signal Ground	Speed/Torque Control
Output → PSO CN1-48	Encoder Output Phase S	Speed/Torque Control, Position Control
Output → /PSO CN1-49	Encoder Output Phase /S	Speed/Torque Control, Position Control
→ Input BAT (+) CN1-21	Battery (+)	Speed/Torque Control, Position Control
→ Input BAT (-) CN1-22	Battery (-)	Speed/Torque Control, Position Control

Use SEN to BAT (-) signals for absolute encoders. See 5.7 *Absolute Encoder* for more details.

Output → SG CN1-1	Single Ground	Speed/Torque Control, Position Control
-------------------	---------------	---

SG: Connect to 0 V on the host controller.

IMPORTANT

When using the Servopack phase C pulse signal to return to the machine origin, always turn the Servomotor at least twice before starting the origin return operation. If the configuration of the mechanical system prevents turning the Servomotor before the origin return operation, then perform the origin return operation at a Servomotor speed of 600 r/min or below. The phase C pulse signal may not be correctly output if the Servomotor is turned faster than 600 r/min.

■ Pulse Divider Setting

Set the pulse dividing ratio in the following user constant.

Pn201	PG Divider	Unit: P/R	Setting Range: 16 to 16384	Factory Setting: 16384	Speed/Torque Control, Position Control

Set the number of pulses for PG output signals (PAO, /PAO, PBO, /PBO) externally output.

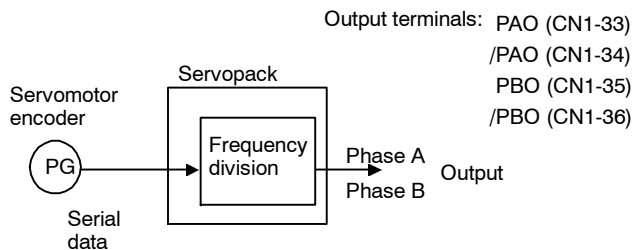

Pulses from the Servomotor encoder (PG) are divided by the preset number of pulses before being output.

The number of output pulses per revolution is set at this user constant. Set the value using the reference units of the equipment or the controller used.

The setting range varies with the encoder used.

Setting Example

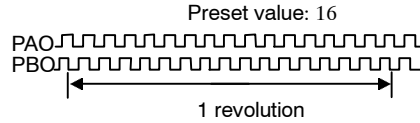

Servomotor Model and Encoder Specifications	Resolution (Bits)	Number of Encoder Pulses Per Revolution (P/R)	Setting Range
A	13	2048 P/R	16 to 2048
B, 1	16	16384 P/R	16 to 16384
C, 2	17		



1. Turn OFF power once and turn ON again after changing the user constant.
2. A 13-bit encoder will run at 2048 P/R even if the setting at Pn201 is set higher than 2049.

5.2.4 Sequence I/O Signals

Sequence I/O signals are used to control Servopack operation. Connect these signal terminals as required.

■ Sink Circuit and Source Circuit

The SERVOPACK's I/O circuit uses a bidirectional photocoupler. Select either the sink circuit or the source circuit according to the specifications required for each machine.

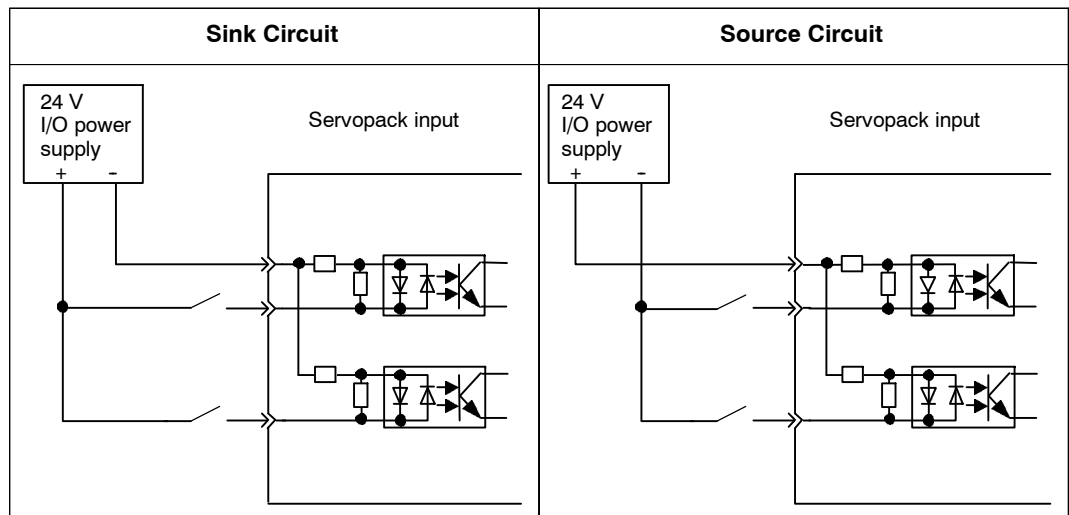

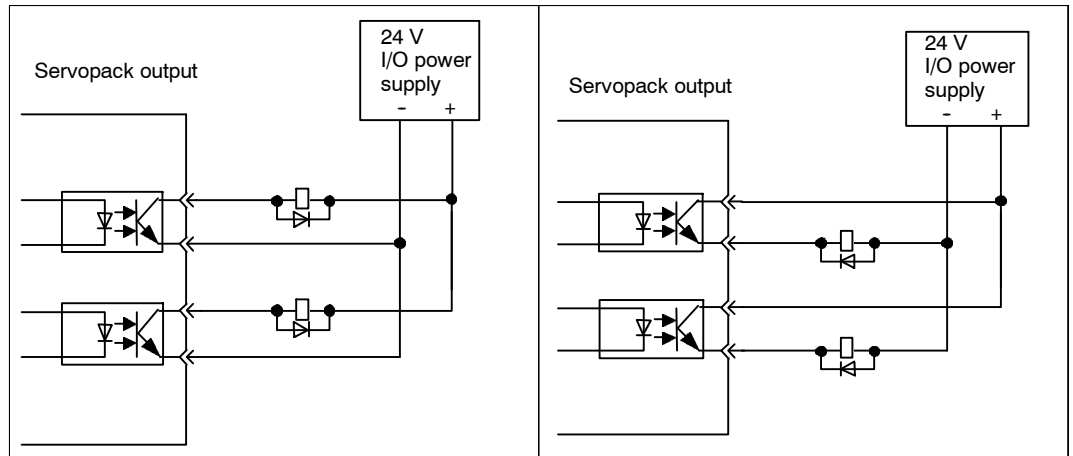

■ Input Signal Connections

Connect the sequence input signals as shown below.

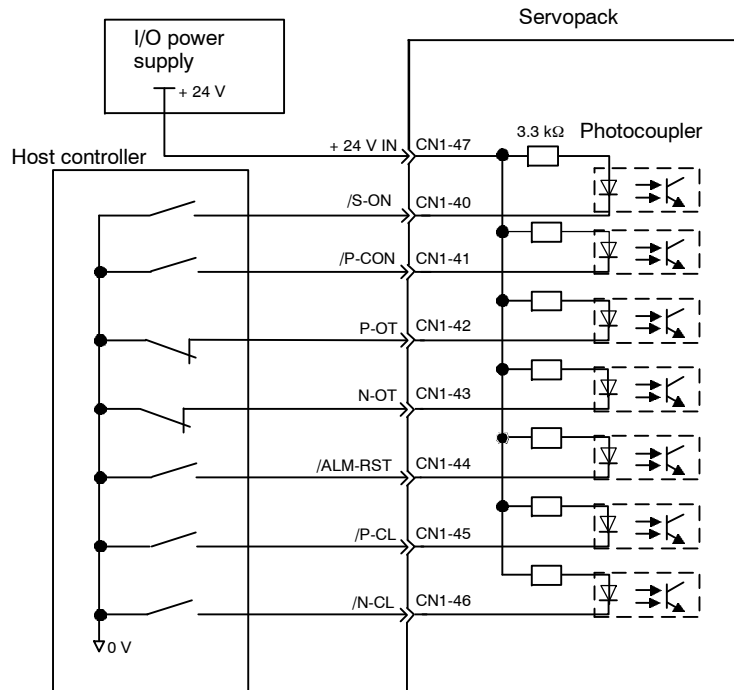

IMPORTANT

Provide an external input power supply; the Servopack does not have an internal 24-V power supply.

- External power supply specifications: 24 ±1 VDC, 50 mA min.

Yaskawa recommends using the same external power supply as that used for output circuits. The allowable voltage range for the 24-V sequence input circuit power supply is 11 to 25 V. Although a 12-V power supply can be used, contact faults can easily occur for relays and other mechanical contacts under low currents. Confirm the characteristics of relays and other mechanical contacts before using a 12-V power supply.

The function allocation for sequence input signal circuits can be changed.

See 5.3.3 *Input Circuit Signal Allocation* for more details.

→ Input +24VIN CN1-47	External I/O Power Supply Input	Speed/Torque Control, Position Control
-----------------------	--	---

The external power supply input terminal is common to sequence input signals.

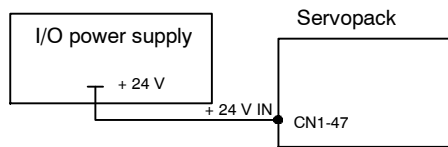

Connect an external I/O power supply.

- Contact input signals: /S-ON (CN1-40)
- /P-CON (CN1-41)
- P-OT (CN1-42)
- N-OT (CN1-43)
- /ALM-RST (CN1-44)
- /P-CL (CN1-45)
- /N-CL (CN1-46)

5

■ Output Signal Connections

Connect the sequence output signals as shown in the following figure.

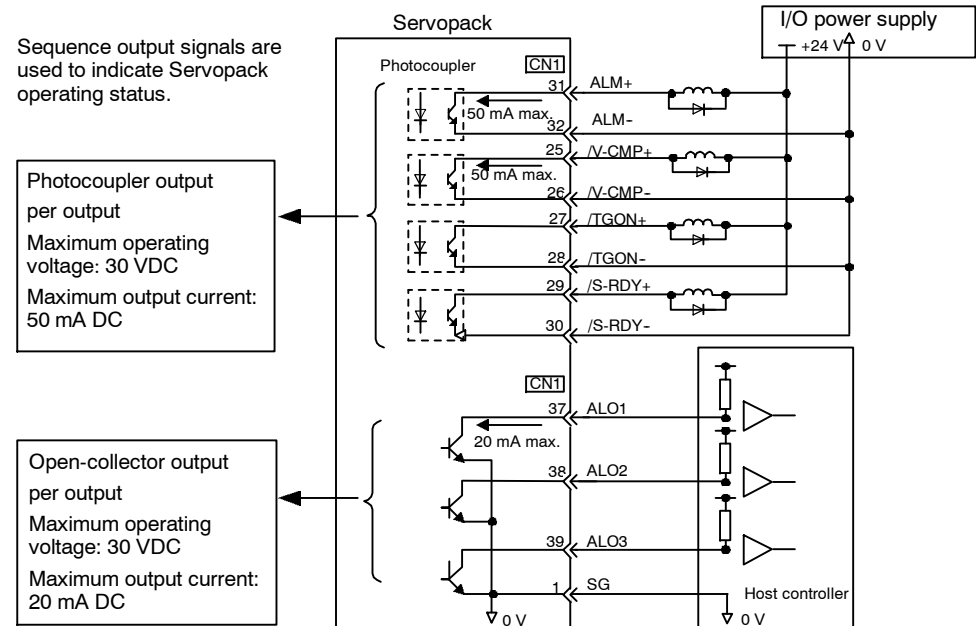

IMPORTANT

Provide a separate external I/O power supply; the Servopack does not have an internal 24-V power supply. Yasukawa recommends using the same type of external power supply as that used for input circuits.

Function allocation for some sequence output signal circuits can be changed.

See 5.3.4 *Output Circuit Signal Allocation* for more details.

5.2.5 Using the Electronic Gear Function

The electronic gear function enables the Servomotor travel distance per input reference pulse to be set to any value. It allows the host controller generating pulses to be used for control without having to consider the equipment gear ratio or the number of encoder pulses.

When the Electronic Gear Function is Not Used

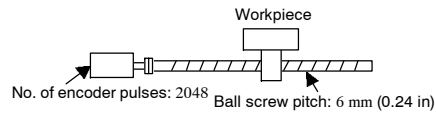

To move a workpiece 10 mm (0.39 in):

1 revolution is 6 mm. Therefore,
 $10 \div 6 = 1.6666$ revolutions
 2048×4 pulses is 1 revolution. Therefore,
 $1.6666 \times 2048 \times 4 = 13653$ pulses
 13653 pulses are input as references.
 The equation must be calculated at the host controller.

When the Electronic Gear Function is Used

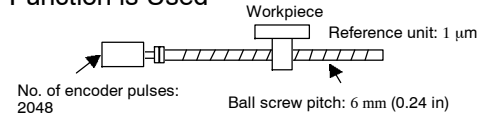

Equipment conditions and reference units must be defined for the electronic gear function beforehand.

To move a workpiece 10 mm (0.39 in):
 Reference unit is 1 μm. Therefore,

$$\frac{10 \text{ mm}}{1 \mu\text{m}} = 10000 \text{ pulses}$$

■ Setting the Electronic Gear

Calculate the electronic gear ratio (B/A) using the following procedure, and set the values in user constants Pn202 and 203.

1. Check equipment specifications.

Items related to the electronic gear:

- Deceleration ratio
- Ball screw pitch
- Pulley diameter

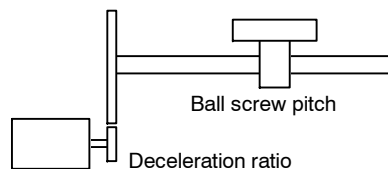

2. Check the number of encoder pulses for the SGM□H Servomotor.

Servomotor Model and Encoder Specifications	Encoder Type	Number of Encoder Pulses Per Revolution (P/R)	
A	Incremental encoder	13-bit	2048
B		16-bit	16384
C		17-bit	32768
1	Absolute encoder	16-bit	16384
2		17-bit	32768



The number of bits representing the resolution of the applicable encoder is not the same as the number of encoder signal pulses (A and B phase) output from the Servopack.

3. Determine the reference unit used.

A reference unit is the minimum position data unit used to move a load. (Minimum unit of reference from the host controller.)

To move a table in 0.001 mm units

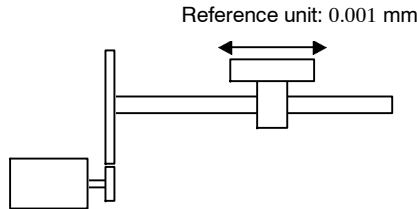

Determine the reference unit according to equipment specifications and positioning accuracy.

EXAMPLE

- 0.01 mm (0.0004 in), 0.001 mm, 0.1°, 0.01 inch.
A reference unit of one pulse moves the load by one reference unit.
- When the reference unit is 1 µm
If a reference of 50000 units is input, the load moves 50 mm (1.97 in) (50000 x 1µm).

4. Determine the load travel distance per load shaft revolution in reference units.

$$\text{Travel distance per load shaft revolution (reference unit)} = \frac{\text{Travel distance per load shaft revolution}}{\text{Reference unit}}$$

EXAMPLE

- When the ball screw pitch is 5 mm (0.20 in) and the reference unit is 0.001 mm

$$\frac{5}{0.001} = 5000 \text{ (reference figure unit)}$$

Ball Screw	Disc Table	Belt and Pulley
<p>Load shaft</p> <p>P</p> <p>P: Pitch</p> <p>1 figure revolution $\frac{P}{\text{reference figure unit}}$</p>	<p>Load shaft</p> <p>1 figure revolution $\frac{360}{\text{reference figure unit}}$</p>	<p>Load shaft</p> <p>πD</p> <p>D: Pulley</p> <p>1 revolution $\frac{\pi D}{\text{reference unit}}$</p>

5. Electronic gear ratio is given as $\frac{B}{A}$

If the decelerator ratio of the motor and the load shaft is given as $\frac{n}{m}$ where m is the rotation of the motor and n is the rotation of the load shaft,

$$\text{Electronic gear ratio } \frac{B}{A} = \frac{\text{No. of encoder pulses}}{\text{Travel distance per load shaft revolution (reference unit)}} \cdot \frac{m}{n}$$

IMPORTANT

Make sure the electronic gear ratio satisfies the following condition:

$$0.01 \leq \text{Electronic gear ratio} \frac{B}{A} \leq 100$$

The Servopack will not work properly if the electronic gear ratio is outside this range. In this case, modify the load configuration or reference unit.

6. Set the user constants.

Reduce the electronic gear ratio $\frac{B}{A}$ to the lower terms so that both A and B are integers smaller than 65535, then set A and B in the respective user constants.

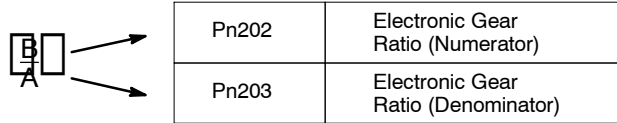

That is all that is required to set the electronic gear ratio.

Pn202	Electronic Gear Ratio (Numerator)	Unit: None	Setting Range: 1 to 65535	Factory Setting: 4	Position Control
Pn203	Electronic Gear Ratio (Denominator)	Unit: None	Setting Range: 1 to 65535	Factory Setting: 1	Position Control

Set the electronic gear ratio according to equipment specifications.

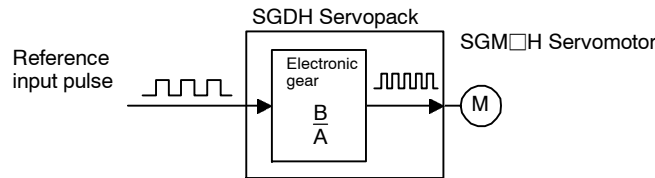

Electronic gear ratio $\frac{B}{A} = \frac{Pn202}{Pn203}$

- $B = [(Number\ of\ encoder\ pulses) \times 4] \times [motor\ speed]$
- $A = [Reference\ units\ (travel\ distance\ per\ load\ shaft\ revolution)] \times [load\ shaft\ revolution\ speed]$

■ Electronic Gear Setting Examples

The following examples show electronic gear settings for different load mechanisms.

Ball Screws

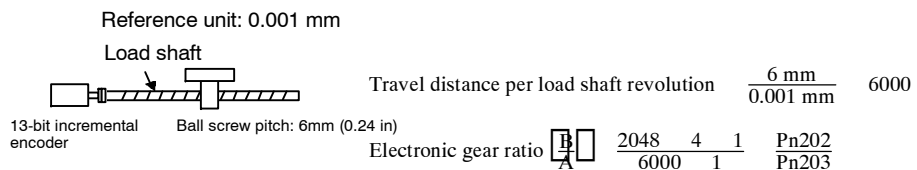

Preset Values	Pn202	8192
	Pn203	6000

Circular Tables

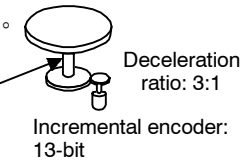

Travel distance per load shaft revolution $\frac{360}{0.1}$

Electronic gear ratio $\frac{B}{A} = \frac{2048}{3600} \cdot \frac{4}{1} \cdot \frac{3}{Pn202} \cdot \frac{Pn203}{Pn203}$

Preset Values	Pn202	24576
	Pn203	3600

Belts and Pulleys

Reference unit: 0.02 mm (0.0008 in)
Load shaft Travel distance per load shaft revolution $\frac{3.14 \cdot 100 \text{ mm}}{0.02 \text{ mm}} = 15700$

Deceleration ratio: 2:1 Pulley diameter: $\phi 100\text{mm}$

Electronic gear ratio $\frac{B}{A} = \frac{16384}{15700} \cdot \frac{4}{1} \cdot \frac{2}{Pn202} \cdot \frac{Pn203}{Pn203}$

$\frac{131072}{15700} = \frac{32768}{3925}$

Set a PG dividing ratio equivalent to 16 bit for the absolute encoder.

Preset Values	Pn202	32768
	Pn203	3925

5

Control Block Diagram

The following diagram illustrates a control block for position control.

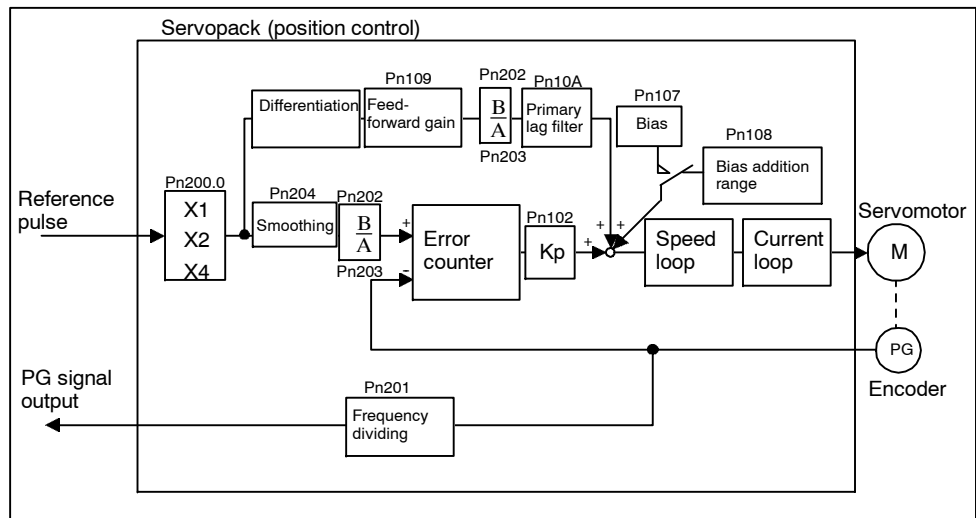

5.2.6 Contact Input Speed Control

The contact input speed control function provides easy-to-use speed control. It allows the user to initially set three different motor speeds with user constants, select one of the speeds externally by contact input, and operate the Servomotor.

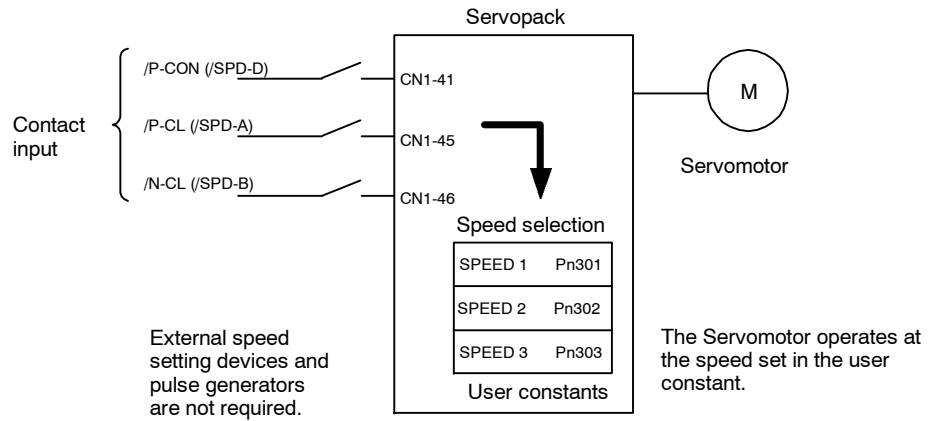

■ Using Contact Input Speed Control

Follow steps 1 to 3 below to use the contact input speed control function.

1. Set contact input speed control as shown below.

Pn000.1	Control Mode Selection	Factory Setting: 0	Speed/Torque Control, Position Control
----------------	-------------------------------	-------------------------------------	---

The speed can be controlled via contact inputs.

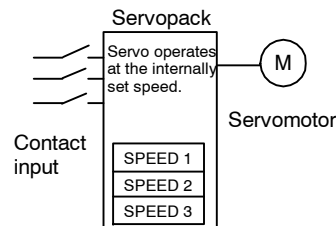

Meanings for the following signals change when the contact input speed control function is used.

Pn000.1 Setting	Description	Input Signal	
0, 1, 2, 7, 8, 9, A, B	Contact input speed control function not used.	/P-CON (CN1-41)	Used to switch between P and PI control.
		/P-CL (CN1-45)	Used to switch between forward external torque limit ON and OFF.
		/N-CL (CN1-46)	Used to switch between reverse external torque limit ON and OFF.

Pn000.1 Setting	Description	Input Signal			
		/P-CON (/SPD-D)	/P-CL (/SPD-A)	/N-CL (/SPD-B)	Speed setting
3, 4, 5, 6	Contact input speed control function used.	Direction of rotation	0	0	0 reference, etc.
		0:Forward	0	1	SPEED 1 (Pn301)
		1:Reverse	1	1	SPEED 2 (Pn302)
			1	0	SPEED 3 (Pn303)

Note 1. 0: OFF (high level); 1: ON (low level)

2. /P-CON, /P-CL and /N-CL functions differ from those in the table above when Pn000.1 is set to 3, 4, 5, or 6. The function is switched automatically when Pn50A.0 is set to 0.
3. The /SPD-D, /SPD-A, and /SPD-B signals can be used only when signals are allocated to the input circuits. See 5.3.3 *Input Circuit Signal Allocation*.

2. Set the motor speeds with the following user constants.

Pn301	Speed 1 (SPEED 1) (Contact Input Speed Control)	Unit: r/min	Setting Range: 0 to 10000	Factory Setting: 100	Speed Control
Pn302	Speed 2 (SPEED 2) (Contact Input Speed Control)	Unit: r/min	Setting Range: 0 to 10000	Factory Setting: 200	Speed Control
Pn303	Speed 3 (SPEED 3) (Contact Input Speed Control)	Unit: r/min	Setting Range: 0 to 10000	Factory Setting: 300	Speed Control

These user constants are used to set motor speeds when the contact input speed control function is selected. If the setting is higher than the maximum motor speed of the Servomotor, then the Servomotor will rotate at its maximum speed.

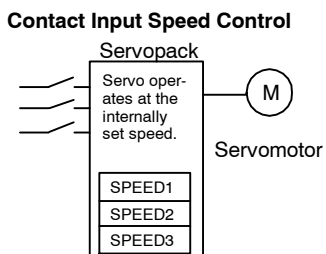

Speed selection input signals /P-CL(/SPD-A)(CN1-45) and /N-CL(/SPD-B)(CN1-46) and the rotation direction selection signal /P-CON (/SPD-D)(CN1-41) enable the Servomotor to run at the preset speeds.

3. Set the soft start time.

Pn305	Soft Start Acceleration Time	Unit: ms	Setting Range: 0 to 10000	Factory Setting: 0	Speed Control
Pn306	Soft Start Deceleration Time	Unit: ms	Setting Range: 0 to 10000	Factory Setting: 0	Speed Control

The Servopack internal speed reference controls speed by applying this acceleration setting.

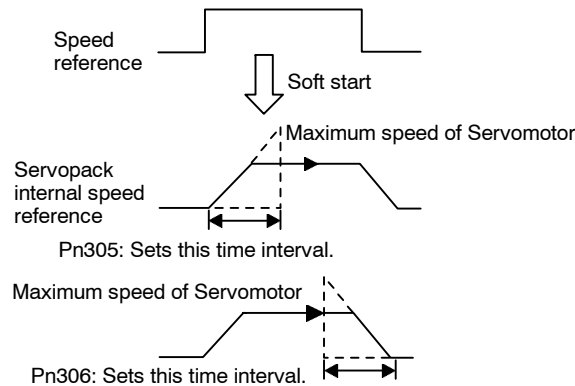

Smooth speed control can be performed by inputting a progressive speed reference or using contact input speed control. Set each constant to 0 for normal speed control.

5

Set each user constant to the following time intervals.

- Pn305: Time interval from when the Servomotor starts until it reaches maximum speed of Servomotor.
- Pn306: Time interval from when the Servomotor maximum speed until it stops.

■ Operation by Contact Input Speed Control

The following describes operation by contact input speed control.

Start and Stop

The following input signals are used to start and stop the Servomotor.

→ Input /P-CL CN1-45	Speed Selection 1 (Forward External Torque Limit Input)	Speed/Torque Control, Position Control
→ Input /N-CL CN1-46	Speed Selection 2 (Reverse External Torque Limit Input)	Speed/Torque Control, Position Control

- Use the following table when contact input speed control is used.

Contact Signal			User Constant	Selected Speed
/P-CON(/SPD-D)	/P-CL (/SPD-A)	/N-CL (/SPD-B)	Pn000.1	
-	0	0	3	Stopped by an internal speed reference of 0.
			4	Analog speed reference (V-REF) input
			5	Pulse reference input (position control)
			6	Analog torque reference input (torque control)
Direction of rotation 0: Forward 1: Reverse	0	1	3, 4, 5, 6 Common	SPEED 1 (Pn301)
	1	1		SPEED 2 (Pn302)
	1	0		SPEED 3 (Pn303)

Note 1. 0: OFF (high level); 1: ON (low level)

- Input signals indicated by the horizontal bar (-) are optional.

- When contact input speed control is not used, input signals are used as external torque limit inputs.



The contact input speed control function is used only when signals are allocated to /SPD-D, /SPD-A, and /SPD-B.

Direction of Rotation Selection

The input signal /P-CON(/SPD-D) is used to specify the direction of Servomotor rotation.

→ Input P-CON CN1-41	Proportional Control Reference, etc.	Speed/Torque Control, Position Control
----------------------	---	---

- When contact input speed control is used, the input signal /P-CON (/SPD-D) specifies the direction of Servomotor rotation.

/P-CON (/SPD-D)	Meaning
0	Forward rotation
1	Reverse rotation

Note 0: OFF (high level); 1: ON (low level)

- When contact input speed control is not used, the /P-CON signal is used for proportional control, zero clamping, and torque/speed control switching.

■ Example of Contact Input Speed Control Operation

The following example shows operation by contact input speed control. Using the soft start function reduces physical shock when the speed is changed.

Contact Input Speed Control

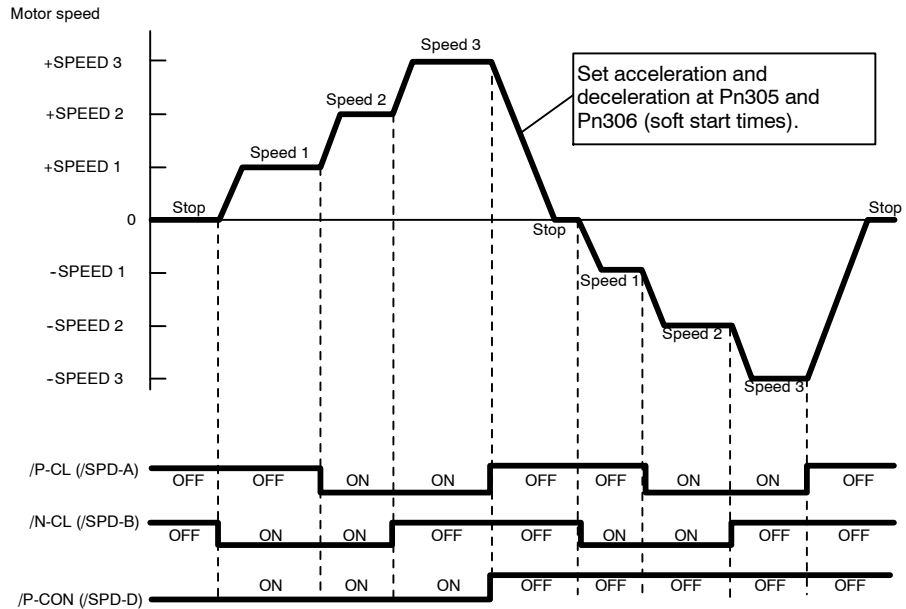

IMPORTANT

The soft start function is available only when contact input speed control is used with Pn000.1 set to 5, and is not available when a pulse reference input is used. If Contact Input Speed Control Mode is switched to Pulse Reference Input Mode while the Servomotor is operating at speed 1, speed 2, or speed 3, the Servopack will not receive a reference pulse until the positioning completed signal /COIN is output. Always start pulse reference output from the host controller after a positioning completed signal is output from the Servopack.

Signal Generation Timing for Position Control

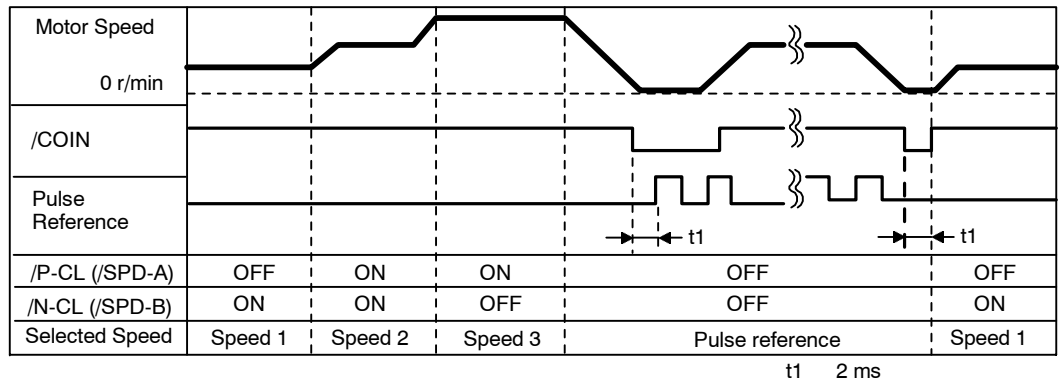

Note 1. The above figure illustrates signal generation timing when the soft start function is used.

2. The value of t_1 is not affected by the use of the soft start function. A maximum 2-ms delay occurs when the /PC-L(/SPD-A) or /N-CL(/SPD-B) signal is read.

5.2.7 Using Torque Control

The SGDM Servopack limits torque as shown below.

- Level 1: Limits maximum output torque to protect the equipment or workpiece.
- Level 2: Limits torque after the Servomotor moves the equipment to a specified position (internal torque limit).
- Level 3: Always control torque rather than speed output.
- Level 4: Switches between speed and torque control.

The following describes uses for levels 3 and 4 in the torque control function.

■ Torque Control Selection

Set in the following user constants to select level 3 or 4 torque control.

Pn000.1	Control Method Selection	Factory Setting: 0	Speed/Torque Control, Position Control
----------------	---------------------------------	-------------------------------------	---

A torque reference is input from the host controller to the Servopack in order to control torque.

Application Examples

- Tension control
- Pressure control

Pn000.1	Control Mode				
<p>2</p>	<p>Torque Control</p> <p>This is a dedicated Torque Control Mode.</p> <ul style="list-style-type: none"> • A torque reference is input from T-REF (CN1-9). • Speed reference input V-REF (CN1-5) cannot be used for speed control if Pn002.1 is set to 1. • User constant Pn407 can be used for maximum speed control. <div style="display: flex; justify-content: space-between; align-items: center;"> <div data-bbox="384 701 616 735"> <p>Application Example</p> </div> <div data-bbox="477 690 1007 863"> </div> </div> <div style="text-align: right; margin-top: 20px;"> </div>				
<p>9</p>	<p>Torque Control <-> Speed Control (Analog Reference)</p> <p>Switches between torque and speed control</p> <ul style="list-style-type: none"> • V-REF (CN1-5) inputs a speed reference or speed limit. • T-REF (CN1-9) inputs a torque reference, torque feed-forward reference or torque limit depending on the control mode. • /P-CON (/C-SEL)(CN1-41) is used to switch between torque and speed control. <table border="1" style="margin-left: auto; margin-right: auto;"> <tr> <td>CN1-41 is open.</td> <td>Torque control</td> </tr> <tr> <td>CN1-41 is 0 V.</td> <td>Speed control</td> </tr> </table> <p>Torque Control: When /P-CON (/C-SEL) is OFF</p> <ul style="list-style-type: none"> • The T-REF reference controls torque. • V-REF can be used to limit Servomotor speed when Pn002.1 is set to 1. V-REF voltage (+) limit Servomotor speed during forward and reverse rotation. • User constant Pn407 can be used to limit the maximum Servomotor speed. <div style="text-align: right; margin-top: 20px;"> </div>	CN1-41 is open.	Torque control	CN1-41 is 0 V.	Speed control
CN1-41 is open.	Torque control				
CN1-41 is 0 V.	Speed control				

Pn000.1	Control Method																							
9	<p>Speed Control: When /P-CON (/C-SEL) is ON</p> <p>Set the user constant Pn002.0 as shown below.</p> <table border="1" style="width: 100%; border-collapse: collapse;"> <thead> <tr> <th style="text-align: center;">User Constant Pn002.0</th> <th style="text-align: center;">Torque Reference Input (T-REF) (CN1-9,10)</th> <th style="text-align: center;">Contents</th> <th style="text-align: center;">Remarks</th> </tr> </thead> <tbody> <tr> <td style="text-align: center;">0</td> <td style="text-align: center;">-</td> <td>Normal speed control</td> <td></td> </tr> <tr> <td style="text-align: center;">1</td> <td>Torque limit input</td> <td>Torque limit speed control by analog voltage reference</td> <td>See 5.2.10 for more details on torque limit speed control by analog voltage reference.</td> </tr> <tr> <td style="text-align: center;">2</td> <td>Torque feed-forward input</td> <td>Speed control with torque feed-forward</td> <td>See 5.2.8 for more details on torque feed-forward speed control.</td> </tr> </tbody> </table>				User Constant Pn002.0	Torque Reference Input (T-REF) (CN1-9,10)	Contents	Remarks	0	-	Normal speed control		1	Torque limit input	Torque limit speed control by analog voltage reference	See 5.2.10 for more details on torque limit speed control by analog voltage reference.	2	Torque feed-forward input	Speed control with torque feed-forward	See 5.2.8 for more details on torque feed-forward speed control.				
User Constant Pn002.0	Torque Reference Input (T-REF) (CN1-9,10)	Contents	Remarks																					
0	-	Normal speed control																						
1	Torque limit input	Torque limit speed control by analog voltage reference	See 5.2.10 for more details on torque limit speed control by analog voltage reference.																					
2	Torque feed-forward input	Speed control with torque feed-forward	See 5.2.8 for more details on torque feed-forward speed control.																					
8	<p>Position Control ↔ Torque Control</p> <p>Can be used to switch between speed (contact reference) and torque control.</p> <ul style="list-style-type: none"> /P-CON (/C-SEL)(CN1-41) is used to switch control. <table border="1" style="width: 100%; border-collapse: collapse;"> <tbody> <tr> <td style="text-align: center;">CN1-41 is open.</td> <td style="text-align: center;">Position control</td> </tr> <tr> <td style="text-align: center;">CN1-41 is 0 V.</td> <td style="text-align: center;">Torque control</td> </tr> </tbody> </table> <p>Position Control When /P-CON (/C-SEL) is OFF</p> <p>Set the user constant Pn002.0 as shown below.</p> <table border="1" style="width: 100%; border-collapse: collapse;"> <thead> <tr> <th style="text-align: center;">User Constant Pn002.0</th> <th style="text-align: center;">Torque Reference Input (T-REF) (CN1-9,10)</th> <th style="text-align: center;">Contents</th> <th style="text-align: center;">Remarks</th> </tr> </thead> <tbody> <tr> <td style="text-align: center;">0</td> <td style="text-align: center;">-</td> <td>Normal position control</td> <td></td> </tr> <tr> <td style="text-align: center;">1</td> <td>Torque limit input</td> <td>Torque limit position control by analog voltage reference</td> <td>See 5.2.10 for more details on torque limit position control by analog voltage reference.</td> </tr> <tr> <td style="text-align: center;">2</td> <td>Torque feed-forward input</td> <td>Position control with torque feed-forward</td> <td>See 5.2.8 for more details on torque feed-forward position control.</td> </tr> </tbody> </table>				CN1-41 is open.	Position control	CN1-41 is 0 V.	Torque control	User Constant Pn002.0	Torque Reference Input (T-REF) (CN1-9,10)	Contents	Remarks	0	-	Normal position control		1	Torque limit input	Torque limit position control by analog voltage reference	See 5.2.10 for more details on torque limit position control by analog voltage reference.	2	Torque feed-forward input	Position control with torque feed-forward	See 5.2.8 for more details on torque feed-forward position control.
CN1-41 is open.	Position control																							
CN1-41 is 0 V.	Torque control																							
User Constant Pn002.0	Torque Reference Input (T-REF) (CN1-9,10)	Contents	Remarks																					
0	-	Normal position control																						
1	Torque limit input	Torque limit position control by analog voltage reference	See 5.2.10 for more details on torque limit position control by analog voltage reference.																					
2	Torque feed-forward input	Position control with torque feed-forward	See 5.2.8 for more details on torque feed-forward position control.																					
6	<p>Speed Control (Contact Reference) ↔ Torque Control</p> <p>Can be used to switch between speed (contact reference) and torque control.</p> <ul style="list-style-type: none"> /P-CON (/C-SEL)(CN1-45) and /N-CL (SPD-B)(CN1-46) are used to switch control. <table border="1" style="width: 100%; border-collapse: collapse;"> <thead> <tr> <th style="text-align: center;">/P-CL (/SPD-A) CN1-45</th> <th style="text-align: center;">/N-CL (/SPD-B) CN1-46</th> <th style="text-align: center;">-</th> <th></th> </tr> </thead> <tbody> <tr> <td style="text-align: center;">0</td> <td style="text-align: center;">0</td> <td style="text-align: center;">-</td> <td>0: OFF</td> </tr> <tr> <td style="text-align: center;">0</td> <td style="text-align: center;">1</td> <td style="text-align: center;">-</td> <td>1: ON</td> </tr> <tr> <td style="text-align: center;">1</td> <td style="text-align: center;">1</td> <td style="text-align: center;">-</td> <td></td> </tr> <tr> <td style="text-align: center;">1</td> <td style="text-align: center;">0</td> <td style="text-align: center;">-</td> <td></td> </tr> </tbody> </table> <p style="text-align: right;">(Contact reference)</p>				/P-CL (/SPD-A) CN1-45	/N-CL (/SPD-B) CN1-46	-		0	0	-	0: OFF	0	1	-	1: ON	1	1	-		1	0	-	
/P-CL (/SPD-A) CN1-45	/N-CL (/SPD-B) CN1-46	-																						
0	0	-	0: OFF																					
0	1	-	1: ON																					
1	1	-																						
1	0	-																						

Note Input signal /C-SEL can be used only when a signal is allocated to the input circuit. See 5.3.3 *Input Circuit Signal Allocation*.

5

Input Signals

Torque Reference Inputs

The following input signals are used for torque control.

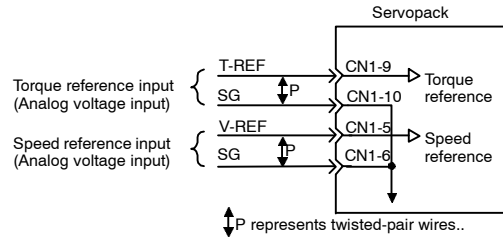

→ Input T-REF CN1-9	Torque Reference Input	Speed/Torque Control
→ Input SG CN1-10	Signal Ground for the Torque Reference Input	Speed/Torque Control

These signals are used when torque control is selected.

Servomotor torque is controlled so that it is proportional to the input voltage between T-REF and SG.

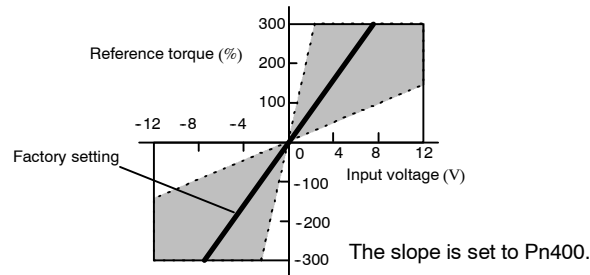

- Factory Settings

Pn400 = 30: This setting means that 3 V is equivalent to the rated torque.

EXAMPLE

+3 V input: Rated torque in the forward direction

+9 V input: 300% of rated torque in the forward direction

-0.3 V input: 10% of rated torque in the reverse direction

User constant Pn400 can be used to change the voltage input range.

- Example of an Input Circuit

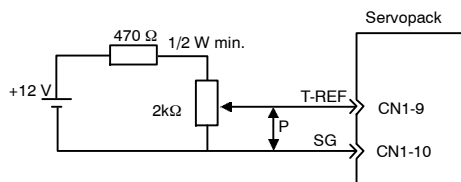

- Always use twisted-pair cables for noise control.
- Recommended variable resistor: Model 25HP-10B manufactured by Sakae Tsushin Kogyo Co., Ltd.

Speed Reference Inputs

Refer to 5.2.1.

Using the /P-CON Signal

→ Input /P-CON CN1-41	Proportional Control, etc.	Speed/Torque Control, Position Control
-----------------------	----------------------------	--

The function of the input signal /P-CON varies with the setting at Pn000.1.

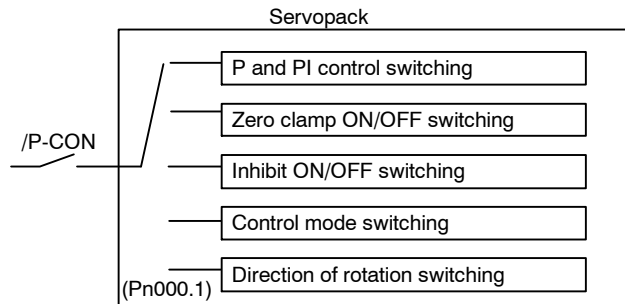

Pn000.1 Setting	/P-CON Function
0, 1	Switches between P (proportional) and PI (proportional-integral) control.
2	Not used.
3, 4, 5, 6	Switches the direction of rotation in Contact Input Speed Control Mode.
7, 8, 9	Switches the control mode.
A	Turns ON/OFF zero clamp.
B	Turns inhibit ON/OFF.



The /P-CON signal function switches automatically when Pn50A.0 is set to 0.

■ User Constant

The following user constant is used for torque control. Set the user constant according to the servo system used.

Pn400	Torque Reference Input Gain	Unit: 0.1 V/rated torque	Setting Range: 10 to 100	Factory Setting: 30	Speed/Torque Control
--------------	------------------------------------	------------------------------------	------------------------------------	-------------------------------	-----------------------------

The user constant sets the voltage range for torque reference input T-REF (CN1-9) according to the output form of the host controller or external circuit.

The factory setting is 30, so the rated torque output is 3 V (30 × 0.1).

5

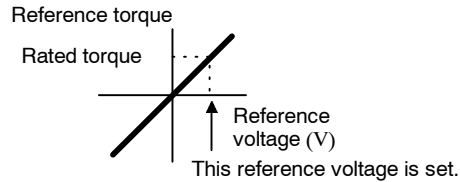

Two speed limit functions during torque control are available by the user constant setting as shown below.

Pn002.1 setting	Description
0	Uses speed limit set by Pn407. (internal speed limit function)
1	Uses V-REF (CN1-5 and 6) as external speed limit input and sets speed limit by voltage which input to V-REF and Pn300. (external speed limit function)

Internal speed limit function

Pn407	Speed Limit during Torque Control	Unit: r/min	Setting Range: 0 to 10000	Factory Setting: 10000	Speed/Torque Control

The user constant sets a motor speed limit when torque control is selected.

It is used to prevent excessive equipment speed during torque control.

Since the speed limit detection signal /VLT functions the same in torque control as the /CLT signal, see 5.1.3 *Limiting Torque*, where the /CLT signal is described.

Torque Control Range

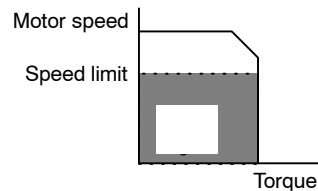

The maximum speed of the Servomotor will be used if Pn407 is set to a value higher than the maximum speed of the Servomotor.

External speed limit function

This is function uses V-REF (CN1-5) as external speed limit input and sets input voltage range by Pn300. Set the range according to host computer and the output state of external circuit.

Pn300	Speed Reference Input Gain	Unit: 0.01V/Rated Speed	Setting Range: 150 to 3000	Factory Setting: 600	Speed/Torque Control

The factory setting is $\pm 1\%$ of the rated motor speed or 6 V.



Principle of Speed Control

Torque reversely proportional to the difference between the speed limit and the speed is fed back to return the system to within the control speed range when the control speed range is exceeded. The actual motor speed limit will thus be increased by negative loads.

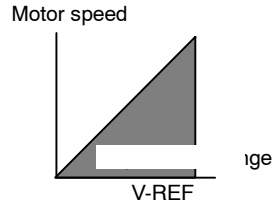

5.2.8 Torque Feed-forward Function

The torque feed-forward function is used only in control mode except for torque control.

This function shortens positioning time, differentiates a speed reference at the host controller to generate a torque feed-forward reference, and inputs this reference together with the speed reference to the Servopack.

Too high a torque feed-forward value will result in overshooting or undershooting. To prevent this, set the optimum value while observing system response.

Connect a speed reference signal line to V-REF (CN1-5 and 6) and a torque feed-forward reference signal line to T-REF (CN1-9 and 10).

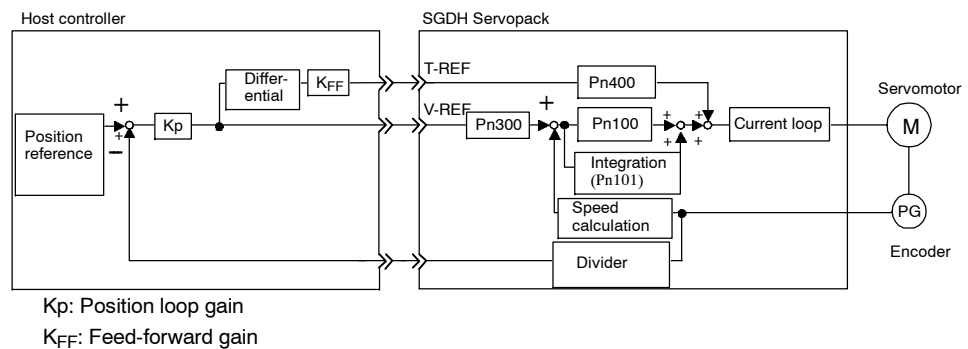

■ Using the Torque Feed-Forward Function

To use the torque feed-forward function, set the following user constant to 2.

Pn002.0	Speed Control Option (T-REF Terminal Allocation)	Factory Setting: 0	Speed Control, Position Control
----------------	---	-----------------------------------	--

This setting enables the torque feed-forward function.

Pn002.0 Setting	Description
0	None.
1	T-REF terminal used for external torque limit input.
2	T-REF terminal used for torque feed-forward input.

5

The torque feed-forward function cannot be used with torque limiting by analog voltage reference described in 5.2.10 *Using Torque Limiting by Analog Voltage Reference*.

■ Setting

Torque feed-forward is set using user constant Pn400.

The factory setting at Pn400 is 30. If, for example, the torque feed-forward value is ± 3 V, then torque is limited to $\pm 100\%$ of the rated torque.

Pn400	Torque Reference Input Gain	Unit: 0.1V/Rated Torque	Setting Range: 10 to 100	Factory Setting: 30	Speed/Torque Control, Position Control
--------------	------------------------------------	--	---	--------------------------------------	---

5.2.9 Speed Feed-forward Function

The speed feed-forward function uses analog voltages and is effective only for position control.

The feed-forward function can be used to shorten positioning time. The host controller creates a feed-forward reference based on the differential of the position reference. This reference is provided to the Servopack with the position reference.

Overshooting and undershooting can result if too much feed-forward is used. Set the optimum settings based on the actual response.

The position reference from the host controller is connected to PULS and SIGN (CN1-7, 8, 11, and 12) and the speed feed-forward reference is connected to V-REF (CN1-5 and 6).

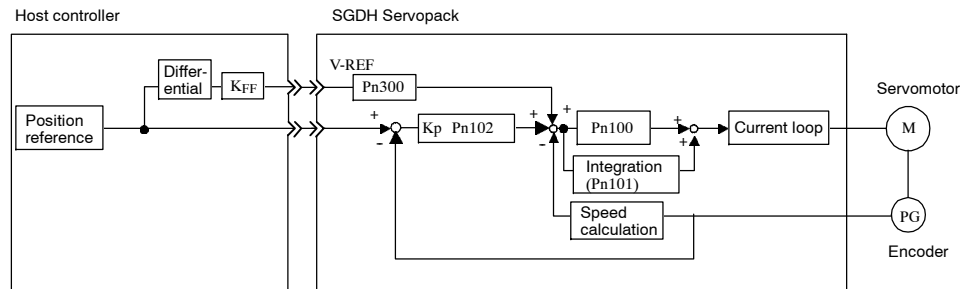

Kp: Position loop gain

K_{FF}: Feed-forward gain

■ Using the Speed Feed-forward Function

Set the following user constant to 1 to use the analog voltage speed feed-forward function.

Pn207.1	Speed Control Option	Factory Setting: 0	Position Control
----------------	-----------------------------	---------------------------	-------------------------

This setting will enable the speed feed-forward function.

Pn207.1 Setting	Description
0	No feed-forward function
1	V-REF terminal used a speed feed-forward input.

■ **Setting**

The speed feed-forward value is set in user constant Pn300.

The factory setting of Pn300 is 600, for which a speed feed-forward value of ±6 V will produce the rated speed.

Pn300	Speed Reference Input Gain	Unit: 0.01V/Rated Speed	Setting Range: 150 to 3000	Factory Setting: 600	Speed/Torque Control, Position Control
--------------	-----------------------------------	-----------------------------------	--------------------------------------	--------------------------------	---

5.2.10 Torque Limiting by Analog Voltage Reference, Function 1

Torque limiting by analog voltage reference limits torque by assigning a torque limit in an analog voltage to the T-REF terminal (CN1-9 and 10). It cannot be used for torque control because the torque reference input terminal T-REF is used as an input terminal.

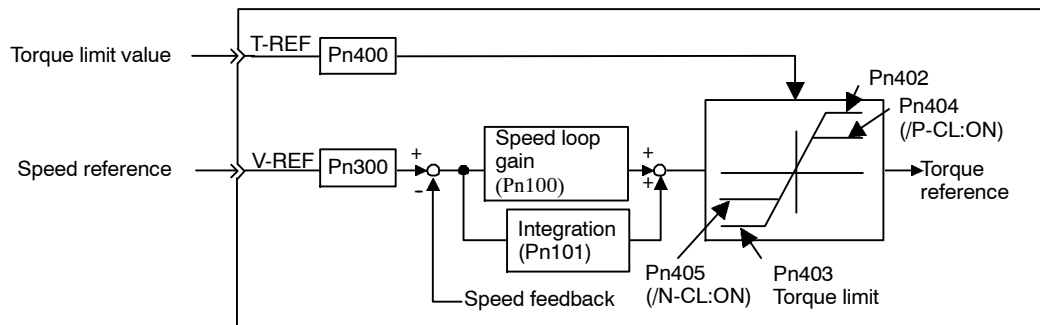

■ **Using Torque Limiting by Analog Voltage Reference**

To use this function, set the following user constant to 1.

Pn002.0	Speed Control Option (T-REF Terminal Allocation)	Factory Setting: 0	Speed Control, Position Control
----------------	---	------------------------------	--

This parameter can be used to enable torque limiting by analog voltage reference.

Torque limiting cannot be set separately for forward and reverse rotation.

Pn002.0 Setting	Description
0	None.
1	T-REF terminal used for external torque limit input.
2	T-REF terminal used for torque feed-forward input.

This function cannot be used with the torque feed-forward function described in 5.2.8 *Using the Torque Feed-forward Function*.

5

■ Setting

The torque limit input gain is set at user constant Pn400.

The factory setting at Pn400 is 30. If, for example, the torque limit is ± 3 V, then torque is limited to 100% of the rated torque. (A torque value higher than 100% torque is clamped at 100%.)

Pn400	Torque Reference Input Gain	Unit: 0.1V/Rated Torque	Setting Range: 10 to 100	Factory Setting: 30	Speed/Torque Control Position Control
--------------	------------------------------------	--	---	--------------------------------------	--

5.2.11 Torque Limiting by Analog Voltage Reference, Function 2

Torque limiting by analog voltage reference limits torque by assigning a torque limit in an analog voltage to the T-REF terminals (CN1-9 and 10). This function cannot be used for torque control because the torque reference input terminal T-REF is used as an input terminal. If the /P-CL signal (CN1-45) is ON, a forward torque limit is applied, and if the /N-CL signal (CN1-46) is ON, a reverse torque limit is applied.

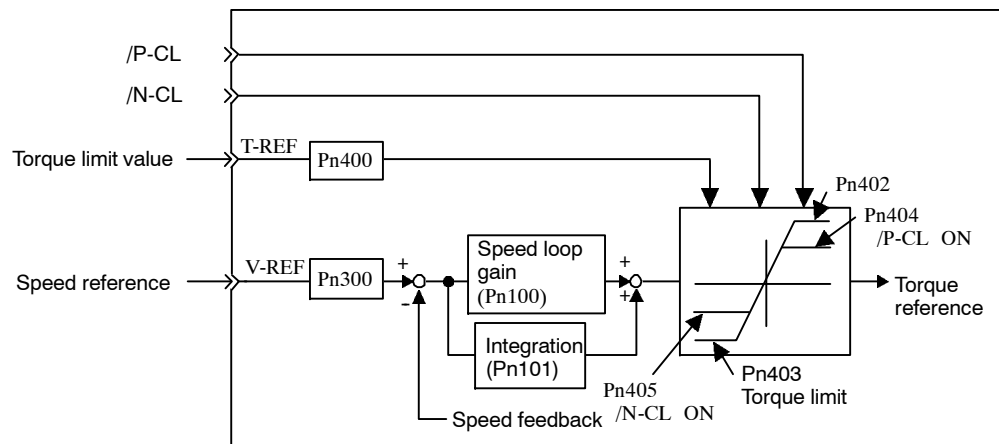

■ Using Torque Limiting by Analog Voltage Reference

To use this function, set the following user constant to 3.

Pn002.0	Speed Control Option (T-REF Terminal Allocation)	Factory Setting: 0	Speed Control, Position Control
----------------	---	-------------------------------------	--

This setting will enable torque limiting by analog voltage reference, function 2.

Pn002.0 Setting	Description
0	None
1	T-REF terminal used for external torque limit input.
2	T-REF terminal used for torque feed-forward input.
3	T-REF terminal used for external torque limiting input when P-CL or N-CL is ON.

This torque limiting function cannot be used at the same time as the torque feed-forward function.

Confirm the allocation of input signals when using this function. (Refer to 5.3.3 *Input Circuit Signal Allocation*.) The factory settings are shown in the following table.

/P-CL	ON and CN1-45 is low	Forward torque limit applied.	Limit: Pn404 or T-REF input, whichever is smaller.
	OFF and CN1-45 is high	Forward torque limit not applied, i.e., normal operation.	-
/N-CL	ON and CN1-46 is low	Reverse torque limit applied.	Limit: Pn405 or T-REF input, whichever is smaller.
	OFF and CN1-46 is high	Reverse torque limit not applied, i.e., normal operation.	-

■ Setting

The torque limit input gain is set at user constant Pn400.

The factory setting at Pn400 is 30. If, for example, the torque limit is ± 3 V, then torque is limited to 100% of the rated torque. (A torque value higher than 100% torque is clamped at 100%. A 100% torque will also be used as the limit if the input torque limit value is -3 V.)

Pn400	Torque Reference Input Gain	Unit: 0.1V/Rated Torque	Setting Range: 10 to 100	Factory Setting: 30	Speed/Torque Control/Position Control
--------------	------------------------------------	-----------------------------------	------------------------------------	-------------------------------	--

The settings of the following user constants are also valid. The torque limit will be either the torque limit value for the analog voltage reference or the setting of Pn404/Pn405, whichever is smaller.

Pn404	Forward External Torque Limit	Unit: %	Setting Range: 0 to 800	Factory Setting: 100	Speed/Torque Control/Position Control
Pn405	Reverse External Torque Limit	Unit: %	Setting Range: 0 to 800	Factory Setting: 100	Speed/Torque Control/Position Control

5

5.2.12 Reference Pulse Inhibit Function (INHIBIT)

This function inhibits the Servopack from counting input reference pulses during position control. The Servomotor remains locked (clamped) while the function is in use. The /P-CON(/INHIBIT) signal is used to enable or disable the function.

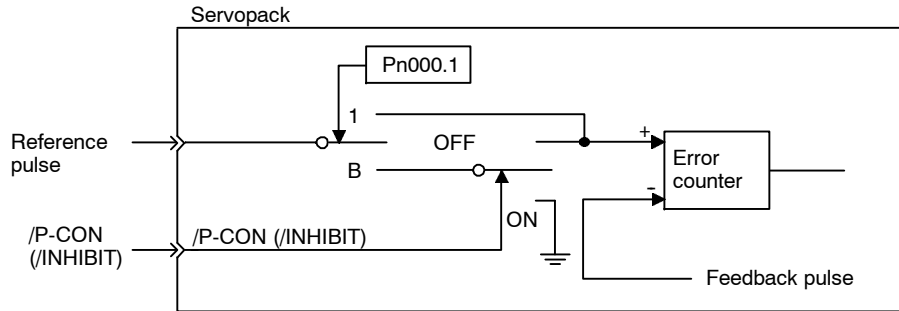

■ Using Reference Pulse Inhibit Function (INHIBIT)

To use the inhibit function, set the user constant as shown below.

Pn000.1	Control Method Selection	Factory Setting: 0	Position Control
----------------	---------------------------------	-------------------------------------	-------------------------

The following settings enable the inhibit function.

Pn000.1 Setting	Description	
1	Enables the inhibit function. Always counts reference pulses.	
B	Enables the inhibit function. The /P-CON (/INHIBIT) signal is used to enable or disable the inhibit function.	
	/P-CON (/INHIBIT)	Description
	OFF	Counts reference pulses.
	ON	Prohibits the Servopack from counting reference pulses. The Servomotor remains locked.

Note Parentheses () around an /INHIBIT signal indicate that a signal has been allocated to the input circuit. See 5.3.3 *Input Circuit Signal Allocation* for more details.

■ Relationship between Inhibit Signal and Reference Pulses

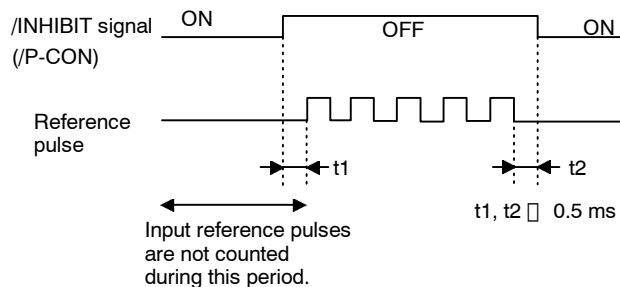

5.3 Setting Up the Servopack

This section describes the procedure for setting user constants to operate the SGDM Servopack.

5.3.1 User Constants

The Σ -II Series Servopack provides many functions and has parameters called user constants that allow the user to specify functions and perform fine adjustments.

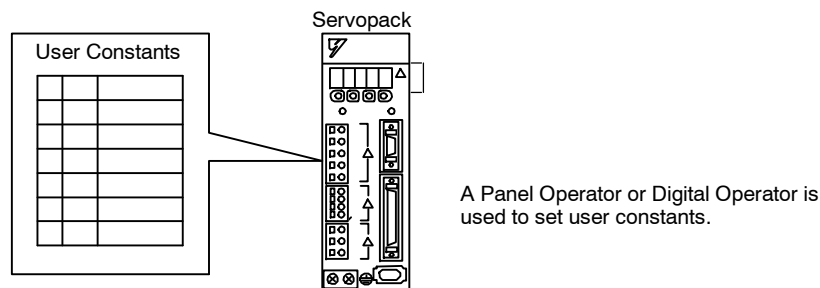

User constants are divided into the following three groups.

User Constant	Function
Pn000 to Pn601	Specify Servopack functions, set servo gains, etc.
Fn000 to Fn013	Execute auxiliary functions such as JOG Mode operations and origin searches.
Un000 to Un00D	Enable monitoring the motor speed and torque reference on the panel display.

Appendix B shows a list of user constants provided for reference. See *6.1.6 Operation in User Constant Setting Mode* for more details on the procedure for setting user constants.

5.3.2 JOG Speed

Use the following user constant to set or modify motor speed when operating the Servomotor from a Panel or Digital Operator.

Pn304	Jog Speed	Unit: r/min	Setting Range: 0 to 10000	Factory Setting: 500	Speed/Torque Control, Position Control
--------------	------------------	-----------------------	-------------------------------------	--------------------------------	---

Use this constant to set the motor speed when operating the Servopack from a Panel or Digital Operator. If the setting is higher than the maximum motor speed of the Servomotor, then the Servomotor will rotate at its maximum speed.

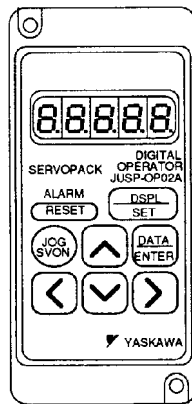

Digital Operator

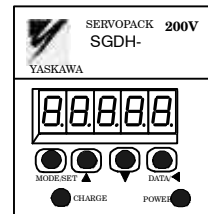

Panel Operator

5.3.3 Input Circuit Signal Allocation

The functions allocated to sequence input signal circuits can be changed. CN1 connector input signals are allocated with the factory settings as shown in the following table.

CN1 Connector Terminal Numbers	Input Terminal Name	Factory Setting	
		Symbol	Name
40	SI0	/S-ON	Servo ON
41	SI1	/P-CON	(Proportional control reference) *
42	SI2	P-OT	Forward run prohibit
43	SI3	N-OT	Reverse run prohibit
44	SI4	/ALM-RST	Alarm reset
45	SI5	/P-CL	(Forward current limit) *
46	SI6	/N-CL	(Reverse current limit) *

* The functions of these input signals are automatically switched according to the setting at user constant Pn000.1 as long as Pn50A.0 is set to 0.

The following user constant is used to enable input signal allocation.

Pn50A.0	Input Signal Allocation Mode	Factory Setting: 0	Speed/Torque Control, Position Control
----------------	-------------------------------------	-------------------------------------	---

Pn50A.0 Setting	Description
0	Factory setting for sequence input signal allocation. This setting is the same as Yaskawa SGDB-□AD□ Servopacks.
1	Enables any sequence input signal settings.



In the factory setting, Pn50A.0 is set to 0. Functions in this manual are generally described for the factory settings.

■ Input Signal Allocation

The following signal can be allocated when Pn50A.0 is set to 1.

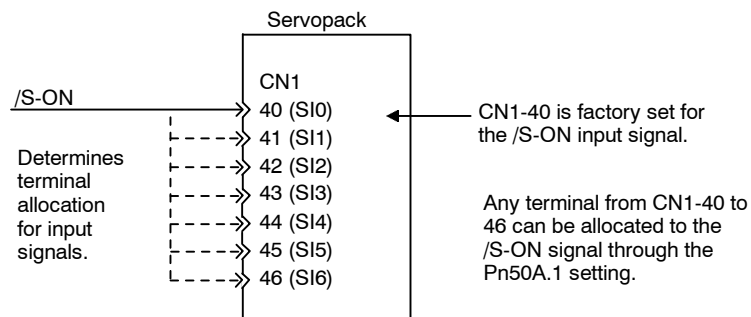

The following table shows the user constant factory settings for input signal selections 1 to 4.

Pn50A	Input Signal Selections 1	Factory Setting: 2100	Speed/Torque Control, Position Control
Pn50B	Input Signal Selections 2	Factory Setting: 6543	Speed/Torque Control, Position Control
Pn50C	Input Signal Selections 3	Factory Setting: 8888	Speed/Torque Control, Position Control
Pn50D	Input Signal Selections 4	Factory Setting: 8888	Speed/Torque Control, Position Control

Select the input terminal on the CN1 connector that will be used for each input signal.

5

- Examples of Input Signal Allocation

The procedure used to allocate sequence input signals is described using the /S-ON signal as a typical example.

Pn50A.1 Setting	Description	Remarks
0	Inputs the /S-ON signal from the SI0 (CN1-40) input terminal.	Signal Polarity: Normal Example: Servo-ON signal (/S-ON) is valid when low (ON).
1	Inputs the /S-ON signal from the SI1 (CN1-41) input terminal.	
2	Inputs the /S-ON signal from the SI2 (CN1-42) input terminal.	
3	Inputs the /S-ON signal from the SI3 (CN1-43) input terminal.	
4	Inputs the /S-ON signal from the SI4 (CN1-44) input terminal.	
5	Inputs the /S-ON signal from the SI5 (CN1-45) input terminal.	
6	Inputs the /S-ON signal from the SI6 (CN1-46) input terminal.	
7	Sets /S-ON signal so that it is always valid.	Set the Servo-ON signal (/S-ON) so that it is always valid or always invalid.
8	Sets /S-ON signal so that it is always invalid.	
9	Inputs the /S-ON signal from the SI0 (CN1-40) input terminal.	Signal Polarity: Reversed Example: Servo-ON signal (/S-ON) is valid when high (OFF).
A	Inputs the /S-ON signal from the SI1 (CN1-41) input terminal.	
B	Inputs the /S-ON signal from the SI2 (CN1-42) input terminal.	
C	Inputs the /S-ON signal from the SI3 (CN1-43) input terminal.	
D	Inputs the /S-ON signal from the SI4 (CN1-44) input terminal.	
E	Inputs the /S-ON signal from the SI5 (CN1-45) input terminal.	
F	Inputs the /S-ON signal from the SI6 (CN1-46) input terminal.	

Note Settings 9 through F can be used to reverse signal polarity.

IMPORTANT

If reverse polarity is set for the Servo-ON, Forward Run Prohibit, or Reverse Run Prohibit signals, safe operation may not occur when troubles, such as broken signal lines, occur. You must confirm operational safety if setting reverse polarity is necessary for one or more of these signals.

As shown in the table above, the /S-ON signal can be allocated to any input terminal from SI0 to SI6. /S-ON is always input when Pn50A.1 is set to 7, and an external signal line would therefore not be needed because the Servopack will determine whether the servo is ON or OFF.

The /S-ON signal is not used when Pn50A.1 is set to 8. This setting is meaningful only in the following instances.

- When the factory set input signal are to be replaced by another input signal.
- The signal must be left ON (low level) during normal operation to make the signal valid when OFF (high level) when forward run prohibit (P-OT) and reverse run prohibit (N-OT) are input. The input terminal signal line must be left ON even in system configu-

rations that do not require this signal, but unnecessary wiring can be eliminated by setting Pn50A.1 to 8.



Signals are input with OR logic when multiple signals are allocated to the same input circuit.

- Allocating Other Input Signals

Input signal allocation can be changed as shown below.

Input Signal		User Constant		Description
Name	Applicable Logic	Number	Setting	
Proportional Control Reference (/P-CON)	ON (low level)	Pn50A.2	0	Inputs the signal on the left from SI0 (CN1-40).
			1	Inputs the signal on the left from SI1 (CN1-41).
			2	Inputs the signal on the left from SI2 (CN1-42).
			3	Inputs the signal on the left from SI3 (CN1-43).
			4	Inputs the signal on the left from SI4 (CN1-44).
			5	Inputs the signal on the left from SI5 (CN1-45).
			6	Inputs the signal on the left from SI6 (CN1-46).
			7	Sets the signal on the left to always enabled.
			8	Sets the signal on the left to always disabled.
			9	Inputs the reverse of the signal on the left from SI0 (CN1-40).
			A	Inputs the reverse of the signal on the left from SI1 (CN1-41).
			B	Inputs the reverse of the signal on the left from SI2 (CN1-42).
			C	Inputs the reverse of the signal on the left from SI3 (CN1-43).
			D	Inputs the reverse of the signal on the left from SI4 (CN1-44).
E	Inputs the reverse of the signal on the left from SI5 (CN1-45).			
F	Inputs the reverse of the signal on the left from SI6 (CN1-46).			
Forward Run Prohibit (/P-OT)	OFF (high level)	Pn50A.3	0 to F	Same as above.*
Reverse Run Prohibit (/N-OT)	OFF (high level)	Pn50B.0	0 to F	Same as above.*
Alarm Reset (/ARM-RST)	ON (low level)	Pn50B.1	0 to F	Same as above.*
Forward Current Limit (/P-CL)	ON (low level)	Pn50B.2	0 to F	Same as above.*
Reverse Current Limit (/N-CL)	ON (low level)	Pn50B.3	0 to F	Same as above.*
Contact Input Speed Control Selection (/SPD-D)	-	Pn50C.0	0 to F	Same as above.*
Contact Input Speed Control Selection (/SPD-A)	-	Pn50C.1	0 to F	Same as above.*
Contact Input Speed Control Selection (/SPD-B)	-	Pn50C.2	0 to F	Same as above.*

Input Signal		User Constant		Description
Name	Applicable Logic	Number	Setting	
Control Mode Selection (/C-SEL)	ON (low level)	Pn50C.3	0 to F	Same as above.*
Zero Clamp (/ZCLAMP)	ON (low level)	Pn50D.0	0 to F	Same as above.*
Reference Pulse Inhibit (/INHIBIT)	ON (low level)	Pn50D.1	0 to F	Same as above.*
Gain Switching (/G-SEL)	ON (low level)	Pn50D.2	0 to F	Same as above.*

* "Same as above" indicates that the user constant can be set to from 0 to F to allocate input signals to the following terminals, as shown in the example for the Proportional Control Reference (/P-CON).

1. Allocation to input terminals SI0 to SI6
2. Setting to always valid or always invalid.
3. Allocation to input terminals SI0 to SI6 and receiving the signals at the Servopack with the reverse logic of the input signal.

5.3.4 Output Circuit Signal Allocation

Output signal functions can be allocated to the sequence signal output circuits shown below.

CN1 Connector Terminal Numbers	Output Terminal Name	Factory Setting		Comments
		Symbol	Name	
25	SO1	/V-CMP+ (/COIN+)	Speed coincidence detection (position- ing completed)	The signal output will vary depend- ing on the control mode.
26 (SG)		/V-CMP- (/COIN-)		
27	SO2	/TGON+	Rotation detection	
28 (SG)		/TGON-		
29	SO3	/S-RDY+	Servo ready	
30 (SG)		/S-RDY-		

The output signal selection user constants and their factory settings are shown below.

Pn50E	Output Signal Selections 1	Factory Setting: 3211	Speed/Torque Control, Position Control
Pn50F	Output Signal Selections 2	Factory Setting: 0000	Speed/Torque Control, Position Control
Pn510	Output Signal Selections 3	Factory Setting: 0000	Speed/Torque Control, Position Control

Select the CN1 connector terminals that will output the signals.

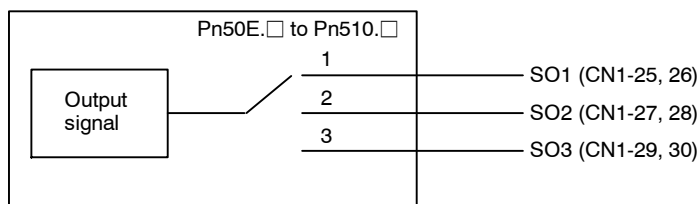

Output Signal	User Constant		Description
	Number	Setting	
Positioning Completed (/COIN)	Pn50E.0	0	Disabled (Not used for the output signal on the left.)
		1	Outputs the signal on the left from the SO1 (CN1-25 and 26) output terminal.
		2	Outputs the signal on the left from the SO2 (CN1-27 and 28) output terminal.
		3	Outputs the signal on the left from the SO3 (CN1-29 and 30) output terminal.
Speed Coincidence Detection (/V-CMP)	Pn50E.1	0 to 3	Same as above
Rotation Detection (/TGON)	Pn50E.2	0 to 3	Same as above
Servo Ready (/S-RDY)	Pn50E.3	0 to 3	Same as above
Torque Limit Detection (/CLT)	Pn50F.0	0 to 3	Same as above
Speed Limit Detection (/VLT)	Pn50F.1	0 to 3	Same as above
Brake Interlock (/BK)	Pn50F.2	0 to 3	Same as above
Warning (/WARN)	Pn50F.3	0 to 3	Same as above
Near (/NEAR)	Pn510.0	0 to 3	Same as above.
Not used.	-	-	-

Note “Same as above” means output signals are disabled or allocated to output terminals SO1 to SO3 through user constant settings 0 to 3.



Signals are output with OR logic when multiple signals are allocated to the same output circuit. Signals that are not detected are invalid. For example, the positioning completed signal /COIN is invalid in Speed Control Mode.

The following user constant can be used to reverse the signals output on output terminals SO1 to SO3.

Pn512	Output Signal Reversal Settings	Factory Setting: 0000	Speed/Torque Control, Position Control
--------------	--	--	---

The settings specify which of the connector CN1 output signals are to be reversed.

Output Terminals	User Constant		Meaning
	Number	Setting	
SO1 (CN1-25, 26)	Pn512.0	0	Output signal not reversed.
		1	Output signal reversed.
SO2 (CN1-27, 28)	Pn512.1	0	Output signal not reversed.
		1	Output signal reversed.
SO3 (CN1-29, 30)	Pn512.2	0	Output signal not reversed.
		1	Output signal reversed.
Not used.	Pn512.3	-	-

5.3.5 Control Mode Selection

The SGDH Servopack offers speed control, position control, torque control, and the other control modes shown in the following table.

The following user constant is used to set the control mode.

Pn000.1	Control Mode Selection	Factory Setting: 0	Speed/Torque Control, Position Control
----------------	-------------------------------	-------------------------------------	---

Pn000.1 Setting	Control Mode
0	Speed Control (Analog Reference)
1	Position Control (Pulse Train Reference)
2	Torque Control (Analog Reference)
3	Contact Input Speed Control Selection (Contact Reference)
4	Contact Input Speed Control Selection (Contact Reference) ↔ Speed Control (Analog Reference)
5	Contact Input Speed Control Selection (Contact Reference) ↔ Position Control (Pulse Train Reference)
6	Contact Input Speed Control Selection (Contact Reference) ↔ Torque Control (Analog Reference)
7	Position Control (Pulse Train Reference) ↔ Speed Control (Analog Reference)
8	Position Control (Pulse Train Reference) ↔ Torque Control (Analog Reference)
9	Torque Control (Analog Reference) ↔ Speed Control (Analog Reference)
A	Speed Control (Analog Reference) ↔ Zero Clamp Control
B	Position Control (Pulse Train Reference) ↔ Position Control (Inhibit)

■ Description of Control Modes

The control modes are described below.

Speed Control (Analog Reference)

This mode controls speed using an analog voltage input reference. See 5.2.1 *Speed Reference*.

Position Control (Pulse Train Reference)

This mode controls positioning using a pulse train input reference. See 5.2.2 *Position Reference*.

Torque Control (Analog Reference)

This mode controls torque using an analog voltage input reference. See 5.2.7 *Using Torque Control*.

Contact Input Speed Control Selection (Contact Reference)

This mode uses the /P-CON (/SPD-D), /P-CL (/SPD-A), and /N-CL (/SPD-B) input signals to control speed as it switches among the three preset operating speeds in the Servopack. See 5.2.6 *Contact Input Speed Control*.

Contact Input Speed Control Selection (Contact Reference) ↔ Speed Control (Analog Reference)

This mode controls speed by switching between contact reference and analog voltage reference speed control. Analog voltage reference speed control is enabled when both /P-CL (/SPD-A) and /N-CL (/SPD-B) input signals are OFF (high level). See 5.2.6 *Contact Input Speed Control*.

Contact Input Speed Control Selection (Contact Reference) ↔ Position Control (Pulse Train Reference)

This mode switches between contact reference speed control and pulse train reference position control. Pulse train reference position control is enabled when both /P-CL (/SPD-A) and /N-CL (/SPD-B) input signals are OFF (high level). See 5.2.6 *Contact Input Speed Control*.

Contact Input Speed Control Selection (Contact Reference) ↔ Torque Control (Analog Reference)

This mode switches between contact reference speed control and analog voltage reference torque control. Torque control using an analog voltage reference is enabled when both /P-CL (/SPD-A) and /N-CL (/SPD-B) input signals are OFF (high level). See 5.2.6 *Contact Input Speed Control*.

Position Control (Pulse Train Reference) ↔ Speed Control (Analog Reference)

This mode switches between position and speed control through the /P-CON (/C-SEL) signal.

Position Control (Pulse Train Reference) ↔ Torque Control (Analog Reference)

This mode switches between position and torque control through the /P-CON (/C-SEL) signal.

Torque Control (Analog Reference) ↔ Speed Control (Analog Reference)

This mode switches between torque and speed control through the /P-CON (/C-SEL) signal. See 5.2.7 *Using Torque Control*.

Speed Control (Analog Reference) ↔ Zero Clamp

This speed control mode is used to set the zero clamp function when the Servopack is stopped. Zero clamp operates when the /P-CON (/ZCLAMP) signal is ON (low level). See 5.4.3 *Using the Zero Clamp Function*.

Position Control (Pulse Train Reference) ↔ Position Control (Inhibit)

This mode controls positioning by inhibiting reference pulse input through the /P-CON (/INHIBIT) signal. See 5.2.12 *Using Reference Pulse Inhibit Function (INHIBIT)*

5.4 Setting Stop Functions

This section describes the procedure used to stop the Servopack stably.

5.4.1 Adjusting Offset

■ When the Servomotor Will Not Stop

The Servomotor may rotate at very low speed and not stop even when 0 V is specified as the reference voltage for Servopack speed and torque control (analog reference). This happens when the reference voltage from the host controller or external circuit is slightly offset (in mV units). The Servomotor will stop if this offset is properly adjusted to 0 V.

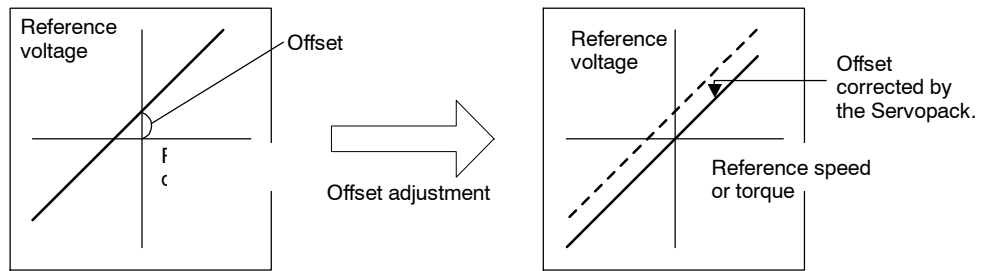

■ Reference Offset Adjustment

The following methods can be used to adjust the reference offset to 0 V.

Automatic Adjustment of Reference Offset	The reference offset is automatically adjusted to 0 V.
Manual Adjustment of Reference Offset	The reference offset can be set to a specified value.

IMPORTANT

Use manual rather than automatic adjustment if a position control loop is formed in the host controller.

See the following sections in *Chapter 6 Using the Digital Operator* for more details on adjustment procedures.

Automatic Adjustment of Reference Offset	6.2.3 <i>Automatic Adjustment of the Speed and Torque Reference Offset</i>
Manual Adjustment of Reference Offset	6.2.4 <i>Manual Adjustment of the Speed and Torque Reference Offset</i>

5

5.4.2 Using the Dynamic Brake

To stop the Servomotor by applying the dynamic brake (DB), set the desired mode in the following user constant. The Servomotor will stop due to equipment friction if the dynamic brake is not applied.

Pn001.0	Servo OFF or Alarm Stop Mode	Factory Setting: 0	Speed/Torque Control, Position Control
----------------	-------------------------------------	-------------------------------------	---

The SGDH Servopack turns OFF under the following conditions:

- The Servo ON input signal (/S-ON, CN1-40) is turned OFF.
- A Servo alarm occurs.
- Main power is turned OFF.

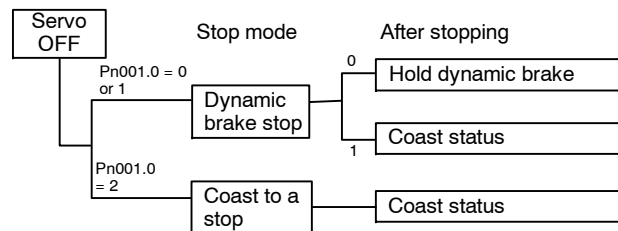

Specify the Stop Mode if any of these occurs during operation.

Pn001.0 Setting	Description
0	Uses the dynamic brake to stop the Servomotor. Maintains dynamic brake after the Servomotor stops. *1
1	Uses the dynamic brake to stop the Servomotor. Releases dynamic brake after the Servomotor stops, and the servomotor coasts to a stop.
2	Coasts the Servomotor to a stop. *2 The Servomotor is turned OFF and motion stops due to equipment friction.

* 1. If the Servomotor is stopped or moving at extremely low speed, it will coast to a stop.

* 2. When the main power supply is turned OFF, the dynamic brakes of the following types of Servopack are used.

30 W to 200 W for 100 V : SGDH-A3BE to -02BD

30 W to 1.5 kW for 200 V : SGDH-A3AE to -04AE

0.5 kW to 7.5 kW for 400 V : SGDH-05DE to -75DE

For the above types of Servopack, the DB circuit is turned ON when the control power supply is OFF.

When the DB circuit should be turned OFF when the main power supply or the control power supply is OFF, disconnect the wiring (U,V, and W) of the Servopack.

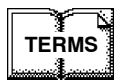

◆ Dynamic brake (DB)

The dynamic brake is a common way of suddenly stopping a Servomotor. Built into the Servopack, the dynamic brake suddenly stops a Servomotor by electrically shorting its electrical circuit.

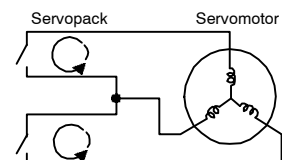

IMPORTANT

The dynamic brake is an emergency stop function. Do not repeatedly start and stop the Servomotor using the servo ON signal (/S-ON) or by repeatedly turning power ON and OFF.

5.4.3 Using the Zero Clamp Function

■ Zero Clamp Function

The zero clamp function is used for systems where the host controller does not form a position loop for the speed reference input. In other words, this function is used to stop and lock the Servomotor even when the input voltage of speed reference V-REF is not 0 V. An internal position loop is temporarily formed to clamp the Servomotor within one pulse when the zero clamp function is turned ON. Even if the Servomotor is forcibly rotated by external force, it will still return to the zero clamp position.

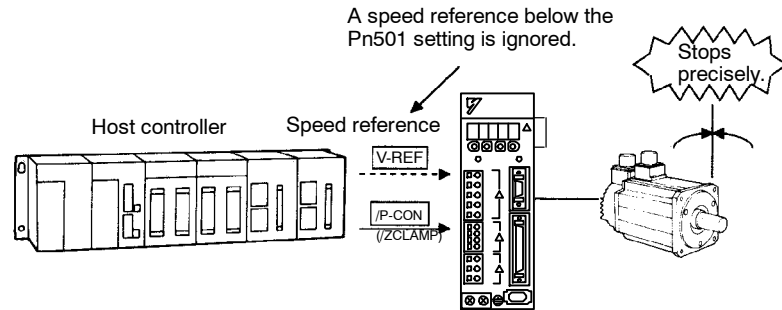

■ User Constant Setting

Set the following user constant so that the input signal /P-CON (/ZCLAMP) can be used to enable or disable the zero clamp function.

Pn000.1	Control Method Selection	Factory Setting: 0	Speed Control
→ Input /P-CON CN1-41		Proportional Control, etc.	Speed/Torque Control, Position Control



The /ZCLAMP signal can be used when an input circuit signal is allocated. See 5.3.3 *Input Circuit Signal Allocation* for more details.

Pn000.1 Setting	Control Mode					
A	<p>Zero Clamp Control Mode</p> <p>This mode allows the zero clamp function to be set when the Servomotor stops.</p> <ul style="list-style-type: none"> The speed reference is input from V-REF (CN1-5). /P-CON (/ZCLAMP)(CN1-41) is used to turn the zero clamp function ON and OFF. <table border="1" data-bbox="727 617 1031 877"> <tr> <td data-bbox="727 617 879 762">CN1-41 is open (OFF).</td> <td data-bbox="879 617 1031 762">Turns the zero clamp function OFF.</td> </tr> <tr> <td data-bbox="727 762 879 877">CN1-41 is 0 V (ON).</td> <td data-bbox="879 762 1031 877">Turns the zero clamp function ON.</td> </tr> </table>	CN1-41 is open (OFF).	Turns the zero clamp function OFF.	CN1-41 is 0 V (ON).	Turns the zero clamp function ON.	<div data-bbox="1082 352 1461 533" style="text-align: right;"> </div> <p>Zero clamp is performed when the following two conditions are satisfied:</p> <p>Condition 1: /P-CON (/ZCLAMP) is ON.</p> <p>Condition 2: Speed reference is below the setting at Pn501.</p>
CN1-41 is open (OFF).	Turns the zero clamp function OFF.					
CN1-41 is 0 V (ON).	Turns the zero clamp function ON.					

■ Setting

Use the following user constant to set the motor speed level at which zero clamp is performed.

Pn501	Zero Clamp Level	Unit: r/min	Setting Range: 0 to 10000	Factory Setting: 10	Speed Control

Set the motor speed at which zero clamp is performed if zero clamp speed control is selected. Even if this value is set higher than the maximum speed of the Servomotor, the maximum speed will be used.

Zero Clamp Conditions

Zero clamp is performed when all the following conditions are satisfied:

- Zero clamp speed control is selected (user constant Pn000.1 is set to A).
- /P-CON (/ZCLAMP)(CN1-41) is ON (0 V).
- Speed reference drops below the setting of Pn501.

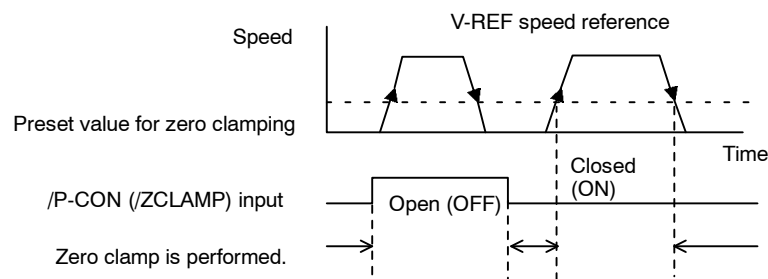



When the /ZCLAMP signal is allocated, the zero clamp operation will be used even for speed control (Pn000.1 = 0).

5.4.4 Using the Holding Brake

The holding brake is used when a Servodrive controls a vertical axis. In other words, a Servomotor with brake prevents the movable part from shifting due to gravity when system power goes OFF.

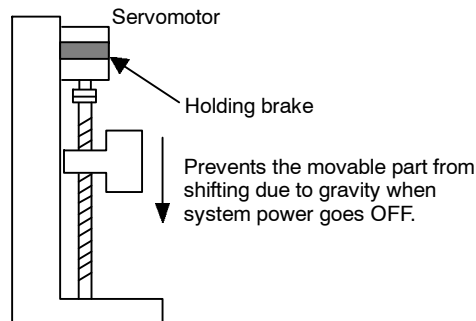

5

IMPORTANT

The brake built into the Servomotor SGM□H with brakes is a de-energization brake, which is used only to hold and cannot be used for braking. Use the holding brake only to hold a stopped motor. Brake torque is at least 120% of the rated motor torque.

■ Wiring Example

Use the Servopack contact output signal /BK and the brake power supply to form a brake ON/OFF circuit. The following diagram shows a standard wiring example.

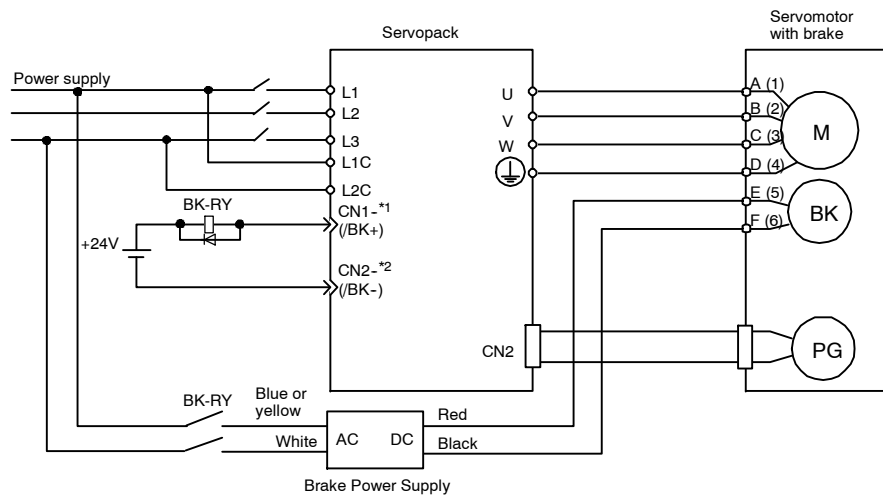

BK-RY: Brake control relay

Brake power supplies are available in 200-V and 100-V models.

*1 and *2 are the output terminals allocated with Pn510.0.

Output /BK	Brake Interlock Output	Speed/Torque Control, Position Control
------------	------------------------	--

This output signal controls the brake when using a Servomotor with a brake and does not have to be connected when using a Servomotor without a brake.

ON: Closed or low level	Releases the brake.
OFF: Open or high level	Applies the brake.

Related User Constants

Pn506	Time Delay from Brake Reference until Servo OFF
Pn507	Speed Level for Brake Reference Output during Motor Operation
Pn508	Timing for Brake Reference Output during Motor Operation

The output signal in the following user constant must be selected when the /BK signal is used.

Pn50F	Output Signal Selections 2	Setting Range: 0000	Speed/Torque Control, Position Control
--------------	-----------------------------------	--------------------------------------	---

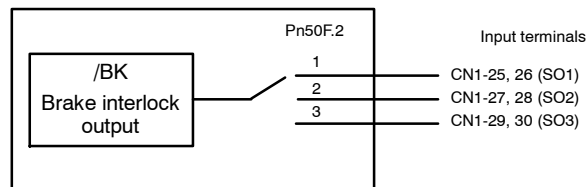

Select the /BK output terminal.

User Constant	Setting	Output Terminal (CN1)	
		*1	*2
Pn50F.2	0	-	-
	1	25	26
	2	27	28
	3	29	30

Note Signals are output with OR logic when multiple signals are allocated to the same output circuit. Set other output signals to a value other than that allocated to the /BK signal in order to output the /BK signal alone. See 5.3.4 *Output Circuit Signal Allocation*.

■ Brake ON Timing

If the equipment moves slightly due to gravity when the brake is applied, set the following user constant to adjust brake ON timing.

Pn506	Brake Reference Servo OFF Delay Time	Unit: 10 ms	Setting Range: 0 to 50	Factory Setting: 0	Speed/Torque Control, Position Control
--------------	---	-----------------------	----------------------------------	------------------------------	---

This user constant is used to set the output time from the brake control signal /BK until the servo OFF operation (Servomotor output stop) when a Servomotor with a brake is used.

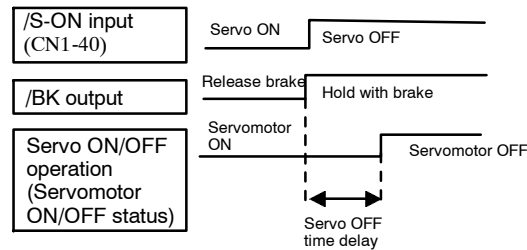

With the standard setting, the servo is turned OFF when the /BK signal (brake operation) is output. The equipment may move slightly due to gravity depending on equipment configuration and brake characteristics. If this happens, use this user constant to delay servo OFF timing.

This setting sets the brake ON timing when the Servomotor is stopped. Use Pn507 and 508 for brake ON timing during operation.

IMPORTANT

The Servomotor will turn OFF immediately if an alarm occurs. The equipment may move due to gravity in the time it takes for the brake to operate.

■ Holding Brake Setting

Set the following user constants to adjust brake ON timing so the holding brake is applied when the Servomotor stops.

Pn507	Brake Reference Output Speed Level	Unit: r/min	Setting Range: 0 to 10000	Factory Setting: 100	Speed/Torque Control, Position Control
Pn508	Timing for Brake Reference Output during Motor Operation	Unit: 10ms	Setting Range: 10 to 100	Factory Setting: 50	Speed/Torque Control, Position Control

Set the brake timing used when the servo is turned OFF by input signal /S-ON (CN1-40) or when an alarm occurs during Servomotor with brake operation.

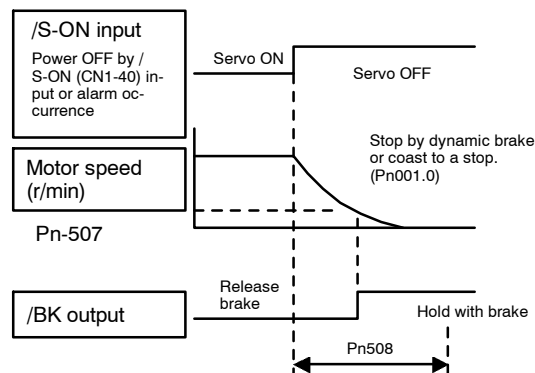

Brake ON timing when the Servomotor stops must be adjusted properly because Servomotor brakes are designed as holding brakes. Adjust the user constant settings while observing equipment operation.

/BK Signal Output Conditions During Servomotor Operation

The circuit is open under either of the following conditions:

1	Motor speed drops below the setting at Pn507 after servo OFF.
2	The time set at Pn508 has elapsed since servo OFF.

The actual setting will be the maximum speed even if Pn507 is set higher than the maximum speed.

5.5 Forming a Protective Sequence

This section describes the procedure for using I/O signals from the Servopack to form a protective safety sequence.

5.5.1 Using Servo Alarm and Alarm Code Outputs

The basic procedure for connecting alarm output signals is described below.

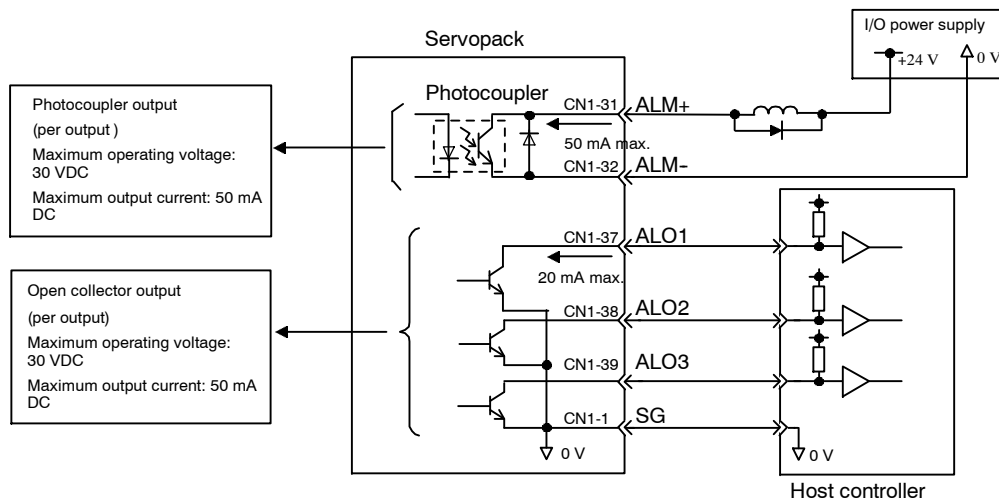

A suitable external I/O power supply must be provided by the user separately because there is no internal 24-V power supply in the Servopack.

The use of the photocoupler outputs is described below.

Output → ALM+ CN1-31	Servo Alarm Output	Speed/Torque Control, Position Control
Output → ALM- CN1-32	Signal Ground for Servo Alarm Output	Speed/Torque Control, Position Control

These alarms are output when a Servopack alarm is detected.

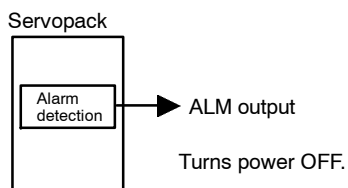

Form an external circuit so this alarm output (ALM) turns the Servopack OFF.

ON: Circuit between CN1-31 and 32 is closed, and CN1-31 is at low level.	Normal state
OFF: Circuit between CN1-31 and 32 is open, and CN1-31 is at high level.	Alarm state

5

Alarm codes ALO1, ALO2 and ALO3 are output to indicate each alarm type.

The uses of open-collector output signals ALO1, ALO2 and ALO3 is described below.

Output → ALO1 CN1-37	Alarm Code Output	Speed/Torque Control, Position Control
Output → ALO2 CN1-38	Alarm Code Output	Speed/Torque Control, Position Control
Output → ALO3 CN1-39	Alarm Code Output	Speed/Torque Control, Position Control
Output → SG CN1-1	Signal Ground for Alarm Code Output	Speed/Torque Control, Position Control

These signals output alarm codes to indicate the type of alarm detected by the Servopack. Use these signals to display alarm codes at the host controller. See 7.2.3 *Alarm Display Table* for more on the relationship between alarm display and alarm code output.

When a Servo alarm (ALM) occurs, eliminate the cause of the alarm and set the following /ALM-RST input signal to high level (ON) to reset the alarm.

→ Input /ALM-RST CN1-44	Alarm Reset	Speed/Torque Control, Position Control
-------------------------	-------------	---

The alarm reset signal is used to reset a Servo alarm.

Form an external circuit so the Servopack turns OFF when an alarm occurs. Alarms are reset automatically when the control power supply is turned OFF.

Alarms can also be reset using a Panel or Digital Operator.

IMPORTANT

1. Encoder alarms cannot always be reset by inputting the /ALM-RST signal. In that case, turn the control power supply OFF to reset the alarm.
2. When an alarm occurs, always eliminate the cause before resetting the alarm. See 7.2.1 *Troubleshooting Problems with Alarm Displays* for more details on troubleshooting the system when an alarm occurs.

5.5.2 Using the Servo ON Input Signal

The basic use and wiring procedure for the Servo ON (/S-ON) input signal (sequence input signal) is described below. Use this signal to forcibly turn OFF the Servomotor from the host controller.

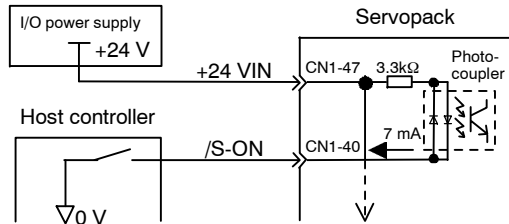

→ Input /S-ON CN1-40	Servo ON	Speed/Torque Control, Position Control
----------------------	-----------------	---

This signal is used to turn the Servomotor ON and OFF.

CN1-40 is ON (Low Level)	Turns the Servomotor ON. This is the normal state (called the Servo ON state).	Servo ON	Servomotor is ON. The Servomotor operates according to signal input.
CN1-40 is OFF (High Level)	The Servomotor is OFF and cannot operate (called the Servo OFF state). Do not turn the Servomotor OFF while it is operating except in an emergency.	Servo OFF	Servomotor is OFF. Servomotor can not operate.

IMPORTANT

Do not use the Servo ON (/S-ON) signal but rather always use an input reference signal to start or stop the Servomotor.

Set the following user constant to 7 if the /S-ON signal will not be used.

Pn50A.1	/S-ON Signal Mapping	Factory Setting: 0	Speed/Torque Control, Position Control
----------------	-----------------------------	-------------------------------------	---

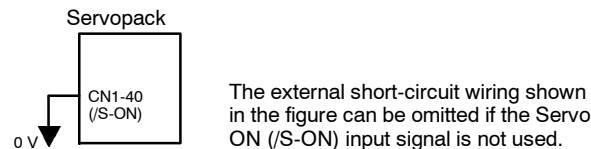

Pn50A.1 Setting	Description
0	Enables the Servo ON (/S-ON) input signal. (The Servo is OFF when CN1-40 is open, and is ON when CN1-40 is at 0 V.)
7	Disables the Servo ON (/S-ON) input signal. (The Servo is always ON, and has the same effect as shorting CN1-40 to 0 V.)

Note See 5.3.3 Input Circuit Signal Allocation for other Pn50A.1 settings.

5.5.3 Using the Positioning Completed Output Signal

The basic use and wiring procedure for the positioning completed (/COIN) output signal (photocoupler output signal) is described below. The signal is output to indicate that Servomotor operation is completed.

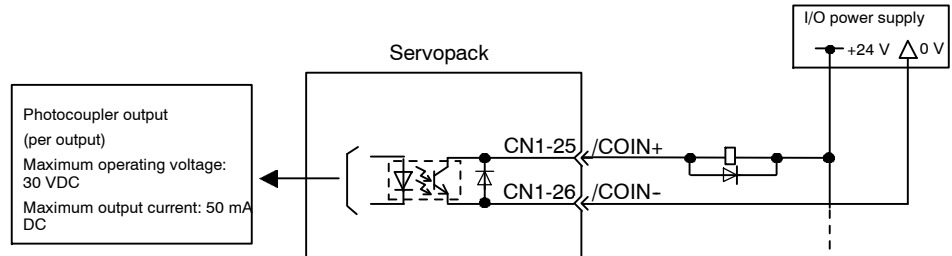

Output → /COIN CN1-25	Positioning Completed Output Signal	Position Control
-----------------------	-------------------------------------	------------------

This signal indicates that Servomotor movement has been completed during position control. The host controller uses the signal as an interlock to confirm on the host controller that positioning is completed.

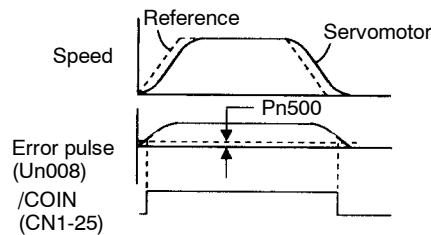

ON: Circuit between CN1-25 and 26 is closed, and CN1-25 is at low level.	Positioning is completed. (Position error is below the setting.)
OFF: Circuit between CN1-25 and 26 is open, and CN1-25 is at high level.	Positioning is not completed. (Position error is above the setting.)

Setting: Pn500 (positioning completed width)

The following user constant setting is used to change the CN1 connector terminal that outputs the /COIN signal.

Pn50E	Output Signal Selections 1	Factory Setting: 3211	Position Control
--------------	-----------------------------------	--	-------------------------

The user constant is factory set so the /COIN signal is output between CN1-25 and 26. See 5.3.4 *Output Circuit Signal Allocation* for more details on user constant Pn50E.

The following user constant is used to set the number of error pulses and to adjust the output timing of the positioning completed signal.

Pn500	Positioning Completed Width	Unit: reference units	Setting Range: 0 to 250	Factory Setting: 7	Position Control
--------------	------------------------------------	--------------------------------------	--	-----------------------------------	-------------------------

This user constant is used to set output timing for the positioning completed signal (/COIN) when the position reference pulse is input and Servomotor operation is completed.

Set the number of error pulses in reference units (the number of input pulses defined using the electronic gear function).

Too large a value set at this user constant may output only a small error during low-speed operation that will cause the /COIN signal to be output continuously.

The positioning completed width setting has no effect on final positioning accuracy.



/COIN is a position control signal.

With the factory setting, this signal is used for the speed coincidence output /V-CMP for speed control, and it is always ON for torque control.

5.5.4 Speed Coincidence Output

The basic use and wiring procedures for the speed coincidence (/V-CMP) output signal used to indicate a match with the speed reference (photocoupler output signal) are described below. The host controller uses the signal as an interlock.

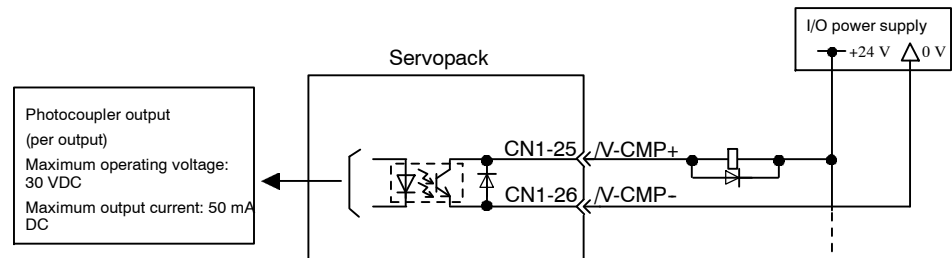

Output → /V-CMP CN1-25	Speed Coincidence Output	Speed Control
-------------------------------	---------------------------------	----------------------

This signal is output when the actual motor speed during speed control is the same as the speed reference input.

ON: Circuit between CN1-25 and 26 is closed, and CN1-25 is at low level.	Speed coincides. (Speed error is below the setting.)
OFF: Circuit between CN1-25 and 26 is open, and CN1-25 is at high level.	Speed does not coincide. (Speed error is above the setting.)

Preset value: Pn503 (Speed Coincidence Signal Output Width)

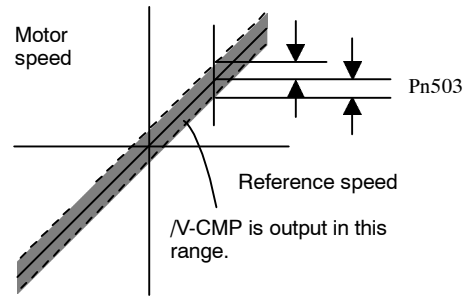

The following user constant setting is used to change the CN1 connector terminal that outputs the \sqrt{V} -CMP signal.

Pn50E	Output Signal Selections 1	Factory Setting: 3211	Speed Control
--------------	-----------------------------------	--	----------------------

The user constant is factory set so the \sqrt{V} -CMP signal is output between CN1-25 and 26. See 5.3.4 *Output Circuit Signal Allocation* for more details on user constant Pn50E.

The following user constant is used to set conditions for speed coincidence output.

Pn503	Speed Coincidence Signal Output Width	Unit: r/min	Setting Range: 0 to 100	Factory Setting: 10	Speed Control
--------------	--	-----------------------	--	--------------------------------------	----------------------

This user constant is used to set conditions for speed coincidence signal \sqrt{V} -CMP output.

The \sqrt{V} -CMP signal is output when the difference between the speed reference and actual motor speed is below this setting.

◀ **EXAMPLE** ▶

The \sqrt{V} -CMP signal turns ON at 1900 to 2100 r/min if the user constant is set to 100 and the reference speed is 2000 r/min.



\sqrt{V} -CMP is a speed control signal.

With the factory setting, this signal is used as the positioning completed signal /COIN for position control, and it is always ON for torque control.

5.5.5 Using the Running Output Signal

The basic use and wiring procedures for the running (/TGON) output signal (photocoupler output signal) are described below. The signal is output to indicate that the Servomotor is currently operating.

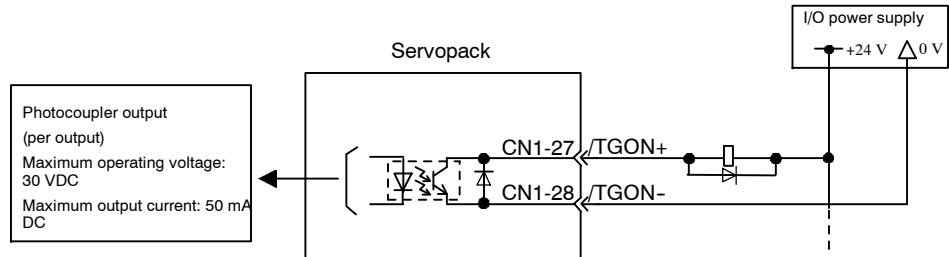

Output → /TGON CN1-27	Running Output Signal	Speed/Torque Control, Position Control
-----------------------	------------------------------	---

This signal is output to indicate that the Servomotor is currently operating. It is used as an external interlock.

ON: Closed or low level	Servomotor is operating. (Motor speed is above the setting.)
OFF: Open or high level	Servomotor is not operating. (Motor speed is below the setting.)

Preset value: Pn502 (Running Output Level)

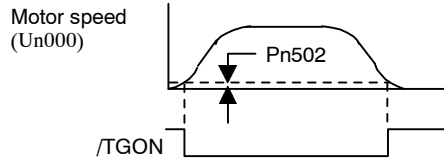

The following user constant setting is used to change the CN1 connector terminal that outputs the /TGON signal.

Pn50E	Output Signal Selections 1	Factory Setting: 3211	Speed/Torque Control, Position Control
--------------	-----------------------------------	--	---

The user constant is factory set so the /V-CMP signal is output between CN1-27 and 28. See 5.3.4 *Output Circuit Signal Allocation* for more details on user constant Pn50E.

This user constant is used to set output conditions for the operation detection output signal /TGON.

Pn502	Rotation Detection Level	Unit: r/min	Setting Range: 1 to 10000	Factory Setting: 20	Speed/Torque Control, Position Control
--------------	---------------------------------	-----------------------	-------------------------------------	-------------------------------	---

This user constant is used to set the speed at which the Servopack determines Servomotor operation and outputs a signal. The following signals are output when motor speed exceeds the preset level.

5

Signals output when Servomotor operation is detected:

- /TGON
- Status Indication Mode
- Monitor Mode Un006

5.5.6 Using the Servo Ready Output Signal

The basic use and wiring procedures for the Servo Ready (/S-RDY) output signal (photocoupler output signal) are described below.

Servo Ready means there are no Servo alarms and the main circuit power supply is turned ON. An added condition with absolute encoder specifications is that the SEN signal is at high level and absolute data was output to the host controller.

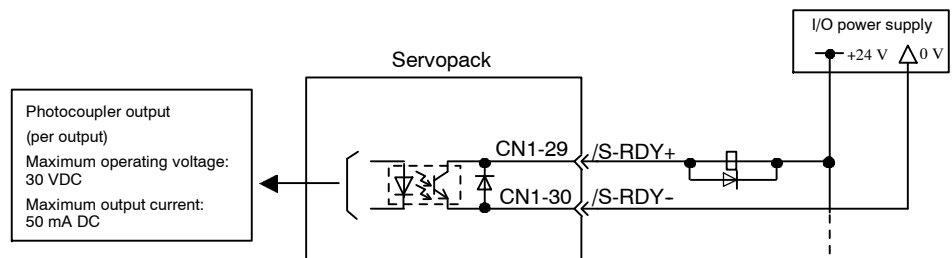

Output → /S-RDY CN1-29

Servo Ready Output Signal

Speed/Torque Control, Position Control

This signal indicates the Servopack received the Servo ON signal and completed all preparations.

ON: Closed or low level	Servo is ready.
OFF: Open or high level	Servo is not ready.

The following user constant setting is used to change the CN1 connector terminal that outputs the /S-RDY signal.

Pn50E	Output Signal Selections 1	Factory Setting: 3211	Speed/Torque Control, Position Control
--------------	-----------------------------------	--	---

The user constant is factory set so the /V-CMP signal is output between CN1-29 and 30. See 5.3.4 *Output Circuit Signal Allocation* for more details on user constant Pn50E.

5.5.7 Using the Warning Output Signal

The basic use and wiring procedure for the warning (/WARN) output signal (photocoupler output signal) are given below.

The signal consists of the following two output signals.

/WARN signals: Overload and regenerative overload

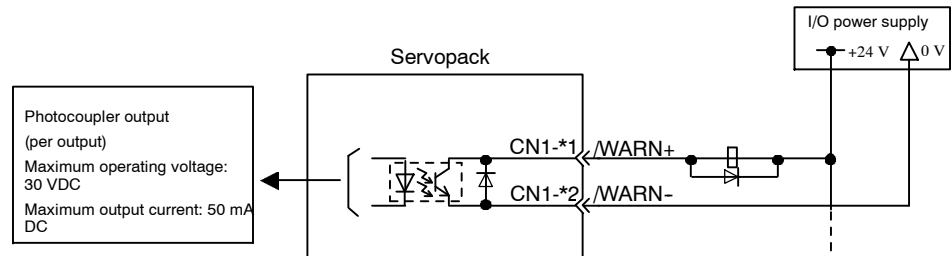

Note User constant Pn50F.3 is used to allocate output terminals for *1 and *2.

Output → /WARN	Warning Output Signal	Speed/Torque Control, Position Control
----------------	-----------------------	--

This output signal indicates an overload or regenerative overload warning.

OFF:	Open or high level	Normal operation.
ON:	Closed or low level	Error warning status

The following user constant setting is used to change the CN1 connector terminal that outputs the /WARN signal.

Pn50F	Output Signal Selections 2	Factory Setting: 0000	Speed/Torque Control, Position Control
--------------	-----------------------------------	---------------------------------	---

Pn50F.3 is used to allocate the /WARN output signals above.

User Constant	Setting	Output Terminal (CN1-)	
		*1	*2
Pn50F.3	0	-	-
	1	25	26
	2	27	28
	3	29	30

Note Multiple signals allocated to the same output circuit are output using OR logic. Set other output signals to a value other than that allocated to the /WARN signal in order to use the /WARN output signal alone. See 5.3.4 Output Circuit Signal Allocation.

5

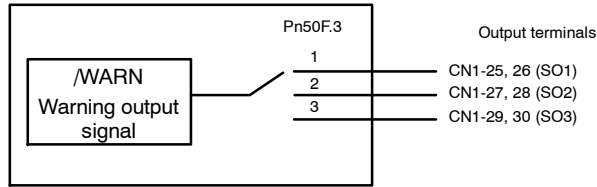

The following user constant is used to output warning details with an alarm code.

Pn001.3	Warning Code Output Selection	Factory Setting: 0	Speed/Torque Control, Position Control
----------------	--------------------------------------	-------------------------------------	---

Pn001.3 Setting	Description
0	Outputs alarm codes alone for alarm codes ALO1, ALO2 and ALO3.
1	Outputs both alarm and warning codes for alarm codes ALO1, ALO2 and ALO3 and outputs an alarm code when an alarm occurs.

The following warning codes are output in 3 bits.

Warning Indication	Warning Code Output			Warning Description
	ALO1	ALO2	ALO3	
A.91	ON signal (low level)	OFF signal (high level)	OFF signal (high level)	Overload
A.92	OFF signal (high level)	ON signal (low level)	OFF signal (high level)	Regenerative overload

5.5.8 Using the Near Output Signal

The basic use and wiring procedures for the near (/NEAR) output signal (photocoupler output signal) are described below. The signal is a sequence signal that is generally output together with the positioning completed signal (/COIN), and it is used to indicate the Servomotor is close to completing operation.

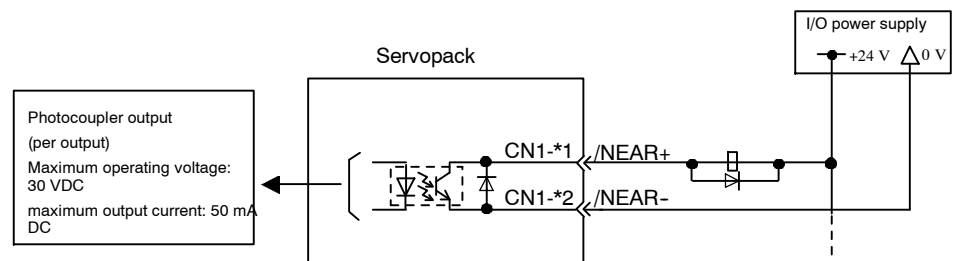

*1 and *2 are the output terminals allocated with Pn510.0.

Output → /NEAR	Near Output Signal	Position Control
-----------------------	---------------------------	-------------------------

The Servopack receives the near signal before the host controller checks the positioning completed signal and prepares the following sequence signal in order to reduce the number of operations required to complete Servomotor operation during position control.

ON: Closed or low level	The Servomotor is close to completing operation. (Position error is below the near signal setting range.)
OFF: Open or high level	The Servomotor is not close to completing operation. (Position error is above the near signal setting range.)

Setting: Pn504 (near signal width)

To use the /NEAR signal, an output terminal must be allocated using the user constant below.

Pn510	Output Signal Selections 3	Factory Setting: 0000	Position Control
--------------	-----------------------------------	--	-------------------------

Pn510.0 is used to allocate the /NEAR output signals above.

User Constant	Setting	Output Terminal (CN1-)	
		*1	*2
Pn510.0	0	-	-
	1	25	26
	2	27	28
	3	29	30

Note Multiple signals allocated to the same output circuit are output using OR logic. Set other output signals to a value other than that allocated to the /NEAR signal in order to use the /NEAR output signal alone. See 5.3.4 *Output Circuit Signal Allocation*.

The following user constant is used to set the timing for /NEAR signal output.

Pn504	NEAR Signal Width	Unit: reference units	Setting Range: 1 to 250	Factory Setting: 7	Position Control
--------------	--------------------------	--	--	-------------------------------------	-------------------------

Generally set the near signal width higher than the positioning completed width. Also see 5.5.3 *Using the Positioning Completed Output Signal*.

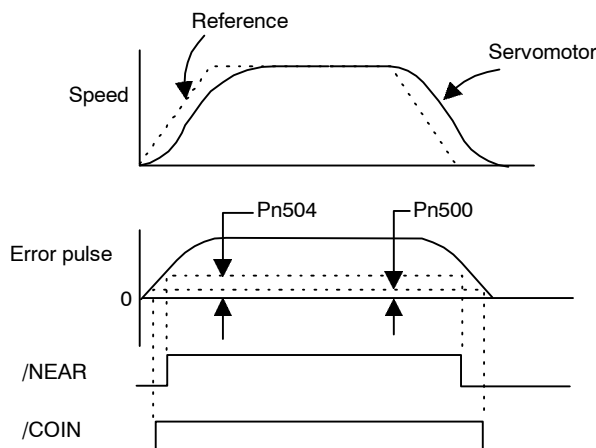

5

5.5.9 Handling Power Loss

The following user constant is used to specify whether the Servomotor holds or continues when a power loss occurs.

Pn509	Momentary Hold Time	Unit: ms	Setting Range: 20 to 1000	Factory Setting: 20	Speed/Torque Control, Position Control
--------------	----------------------------	--------------------	-------------------------------------	-------------------------------	---

The Servopack turns the Servomotor OFF if it detects an instantaneous voltage drop in the power supply. This factory setting of 20 ms means that Servomotor operation will continue if power is lost for less than 20 ms.

In the following instances, however, a Servo alarm is generated or control is lost (equivalent to normal power OFF operation) regardless of the user constant setting.

- When an insufficient voltage alarm (A.41) occurs during power loss with a large Servomotor load.
- When control is lost (equivalent to normal power OFF operation) with loss of the control power supply.

In power loss detection, the status of the main circuit power supply is detected and OFF status is ignored so Servomotor operation will continue if the Servomotor turns back ON within the time set at user constant Pn509.

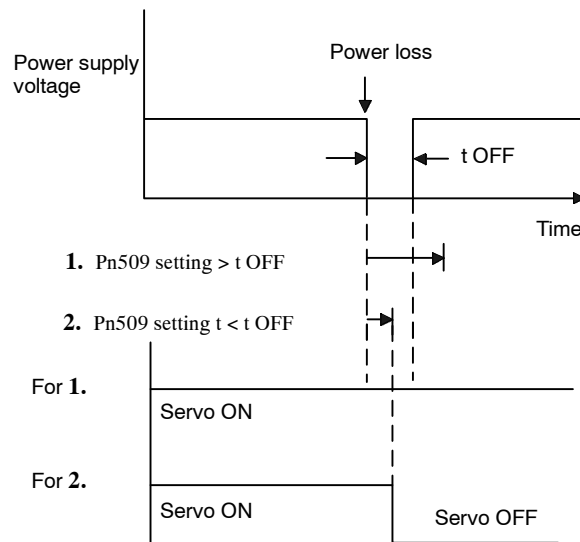

5.6 Selecting a Regenerative Resistor

When the Servomotor is driven in generator mode, power is returned to the Servopack. This is called regenerative power. The regenerative power is absorbed by charging the smoothing capacitor, but when the chargeable energy is exceeded, the regenerative power is further consumed by the regenerative resistor.

The Servomotor is driven in regeneration (generator) mode in the following circumstances:

- While decelerating to a stop during acceleration and deceleration operation.
- With a load on the vertical axis.
- During continuous operation with the Servomotor rotated from the load side (negative load).

The capacity of the Servopack's built-in regenerative resistor is sufficient for short-time operation only, such as for the deceleration stop period. Operation under a negative load is not possible.

If the regenerative power exceeds the processing capacity of the Servopack, then install an external regenerative resistor. The following table shows the specifications of the Servopack's built-in resistor and the amount of regenerative power (average values) that it can process.

Applicable Servopacks		Specifications of Built-in Resistor		Regenerative Power Processed by Built-in Resistor*1 (W)	Minimum Allowable Resistance (Ω)
		Resistance (Ω)	Capacity (W)		
Single-phase 100 V	SGDH-A3BE to -02BE	-	-	-	40
	SGDH-A3AE to -04AE	-	-	-	40
Single-phase 200 V	SGDH-08AE-S	50	60	12	40
	SGDH-15AE-S	25	140	28	20
	SGDH-05AE to -10AE	50	60	12	40
Three-phase 200 V	SGDH-15AE	30	70	14	20
	SGDH-20AE	25	140	28	12
	SGDH-30AE	12.5	140	28	12
	SGDH-50AE	8	280	56	8
	SGDH-60AE	(6.25)*2	(880)*2	(180)*2	5.8
	SGDH-75AE to -1EAE	(3.13)*3	(1760)*3	(350)*3	2.9
	SGDH-05DE to -15DE	108	70	14	73
Three-phase 400 V	SGDH-20DE, -30DE	45	140	28	44
	SGDH-50DE	32	180	36	28
	SGDH-60DE to -75DE	(18)*4	(880)*4	(180)*4	18
	SGDH-1ADE to -1EDE	(14.25)*5	(1760)*5	(350)*5	14.2

- * 1. The average regenerative power that can be handled is 20% of the rated capacity of the regenerative resistor built into the Servopack.
- * 2. The values in parentheses are for the optional JUSP-RA04 Regenerative Resistor Unit.
- * 3. The values in parentheses are for the optional JUSP-RA05 Regenerative Resistor Unit.
- * 4. The values in parentheses are for the optional JUSP-RA18 Regenerative Resistor Unit.
- * 5. The values in parentheses are for the optional JUSP-RA19 Regenerative Resistor Unit.

When installing an external regenerative resistor, make sure that the resistance is the same as that of the Servopack's built-in resistor. If combining multiple small-capacity regenerative resistors to increase the regenerative resistor capacity (W), select resistors so that the resistance value including error is at least as high as the minimum allowable resistance shown in the above table.

5.6.1 External Regenerative Resistors

When installing an external regenerative resistor, a user constant setting must be changed as shown below.

Pn600	Regenerative Resistor Capacity	Unit: 10 W	Setting Range: 0 to Servopack capacity	Factory Setting: 0	Speed/Torque Control, Position Control
--------------	---------------------------------------	-----------------------	---	-------------------------------	---

The factory setting of "0" in the above table is the set value used when the Servopack's built-in resistor is used or when a Servopack without a built-in resistor is used.

When installing an external regenerative resistor, set the regenerative resistor's capacity (W).

◀EXAMPLE▶

When the external regenerative resistor's actual consumable capacity is 100 W, set the user constant to "10."

IMPORTANT

1. In general, when resistors for power are used at the rated load ratio, the resistor temperature increases to between 200°C and 300°C. The resistors must be used at or below the rated values. Check with the manufacturer for the resistor's load characteristics. Use resistors at no more than 20% of the rated load ratio with natural convection cooling, and no more than 50% of the rated load ratio with forced air cooling.
2. For safety's sake, it is recommended that resistors with thermostats be used.

■ Connecting Regenerative Resistors

The method for connecting regenerative resistors is shown below.

Servopacks with Capacities of 400 W or Less

Connect an external regenerative resistor between the Servopack's B1 and B2 terminals.

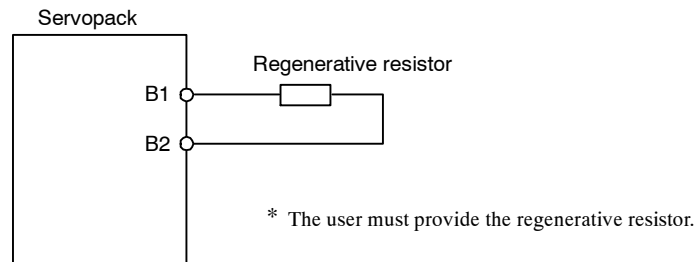

Servopacks with Capacities of 0.5 to 5.0 kW

Disconnect the wiring between the Servopack's B2 and B3 terminals and connect an external regenerative resistor between the B1 and B2 terminals.

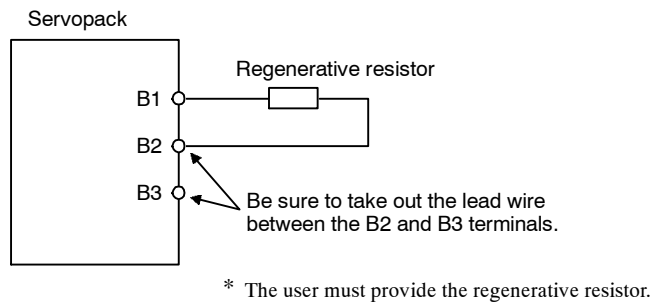

Servopacks with Capacities of 6.0 kW or More

Servopacks with capacities of 6.0 kW or more do not have regenerative resistors built in. A regenerative resistor must be connected externally. The following Regenerative Resistor Units are available for this purpose.

Servopack	Applicable Regenerative Resistor Unit	Resistance (Ω)	Specifications
SGDH-60AE	JUSP-RA04	6.25	25 Ω (220 W) \times 4 resistors in parallel
SGDH-75AE to -1EAE	JUSP-RA05	3.13	25 Ω (220 W) \times 8 resistors in parallel
SGDH-60DE, -75DE	JUSP-RA18	18	18 Ω (220 W) \times 4 resistors in serial-parallel
SGDH-1ADE, 1EDE	JUSP-RA19	14.25	28.5 Ω (220 W) \times 8 resistors in serial-parallel

5

Connect the Servopack and Regenerative Resistor Unit as shown in the following diagram.

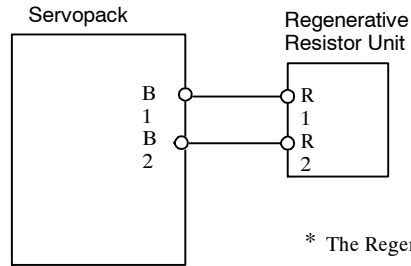

* The Regenerative Resistor Unit is sold as an option.

IMPORTANT

Regenerative resistors reach high temperatures, so be careful to cool them. Also use heat-resistant, non-flammable wiring and make sure that the wiring does not come into contact with the resistors.

5.6.2 Calculating the Required Capacity of Regenerative Resistors

■ By Means of a Simple Calculation

When driving a Servomotor normally with the horizontal axis, check the external regenerative resistor requirements using the calculation method shown below.

Servopacks with Capacities of 400 W or Less

Servopacks with capacities of 400 W or less do not have built-in regenerative resistors. The energy that can be charged by capacitors is shown in the following table. If the rotational energy in the servo system exceeds these values, then connect a regenerative resistor externally.

Voltage	Applicable Servopacks	Regenerative Energy that Can be Processed (joules)	Remarks
100 V	SGDH-A3BE	7.8	Value when main circuit input voltage is 100 VAC
	SGDH-A5BE to -02BE	15.7	
200 V	SGDH-A3AE, -A5AE	18.5	Value when main circuit input voltage is 200 VAC
	SGDH-01AE to -04AE	37.1	

Calculate the rotational energy in the servo system from the following equation:

$$E_S = J \times (N_M)^2 / 182 \text{ (joules)}$$

- $J = J_M + J_L$
- J_M : Servomotor rotor inertia ($\text{kg}\cdot\text{m}^2$) ($\text{oz}\cdot\text{in}\cdot\text{s}^2$)
- J_L : Motor axis conversion load inertia ($\text{kg}\cdot\text{m}^2$) ($\text{oz}\cdot\text{in}\cdot\text{s}^2$)
- N_M : Rotation speed used by Servomotor (r/min)

Servopacks with Capacities of 0.5 to 5.0 kW

Servomotors with capacities of 0.5 to 5.0 kW have built-in regenerative resistors. The allowable frequencies for just the Servomotor in acceleration and deceleration operation, during the rotation speed cycle from 0 to the maximum rotation speed to 0, are summarized in the following table.

Convert the data into the values obtained with actual rotation speed used and load inertia to determine whether an external regenerative resistor is needed.

Voltage	Series	Allowable Frequencies in Regeneration Mode (r/min)											
		Capacity Symbol	03	05	06	08	09	10	12	13	15	20	30
200 V	SGMAH		-	-	-	89	-	-	-	-	-	-	-
	SGMPH		-	-	-	29	-	-	-	-	17	-	-
	SGMGH-□A□A		-	34	-	-	13	-	-	10	-	12	8
	SGMGH-□A□B		96	-	39	-	22	-	15	-	-	20	13
	SGMSH		-	-	-	-	-	39	-	-	31	48	20
400 V	SGMGH		-	42	-	-	15	-	-	10	-	12	8
	SGMSH		-	-	-	-	-	47	-	-	31	48	20
	SGMUH		-	-	-	-	-	27	-	-	19	-	13

Voltage	Series	Allowable Frequencies in Regeneration Mode (r/min)					
		Capacity Symbol	22	32	40	44	50
200 V	SGMGH-□A□A		-	-	-	11	-
	SGMGH-□A□B		-	-	20	-	-
	SGMSH		-	-	29	-	22
	SGMDH		7	11	8	-	-
400 V	SGMGH		-	-	-	11	-
	SGMSH		-	-	29	-	22
	SGMUH		-	-	19	-	-

5

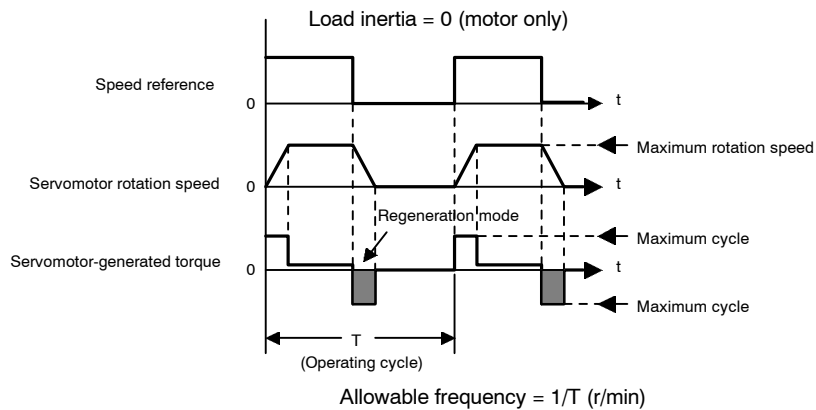

Figure 5.1 Operating Conditions for Allowable Regenerative Frequency Calculation

Use the following equation to calculate the allowable frequency for regeneration mode operation.

$$\text{Allowable frequency} = \frac{\text{Allowable frequency for Servomotor only}}{(1 - n)} \times \frac{\text{Max. rotation speed}^2}{\text{Rotation speed used}^2} \text{ (r/min)}$$

- $n = J_I/J_M$
- J_M : Servomotor rotary inertia ($\text{kg}\cdot\text{m}^2$) ($\text{oz}\cdot\text{in}\cdot\text{s}^2$)
- J_L : Motor axis conversion load inertia ($\text{kg}\cdot\text{m}^2$) ($\text{oz}\cdot\text{in}\cdot\text{s}^2$)

Servopacks with Capacities of 6.0 kW or More

Servopacks with capacities of 6.0 kW or more do not have built-in regenerative resistors. The following table shows the allowable frequencies in regeneration mode when the Servopack is combined with the JUSP-RA04 or JUSP-RA05 Regenerative Resistor Unit.

The equation used to calculate the allowable frequency from the Servomotor drive conditions and load inertia are the same as the one give above for Servopack with capacities of 0.5 to 5.0 kW.

Voltage	Series	Allowable Frequencies in Regeneration Mode (r/min)			
	Capacity Symbol	55	75	1A	1E
200 V	SGMGH-□A□A	26	36	36	32
	SGMGH-□A□B	44	-	-	-
400 V	SGMGH-□D	26	18	36	32

■ By Calculating the Regenerative Energy

This section shows the procedure for calculating the regenerative resistor capacity when acceleration and deceleration operation is as shown in the following diagram.

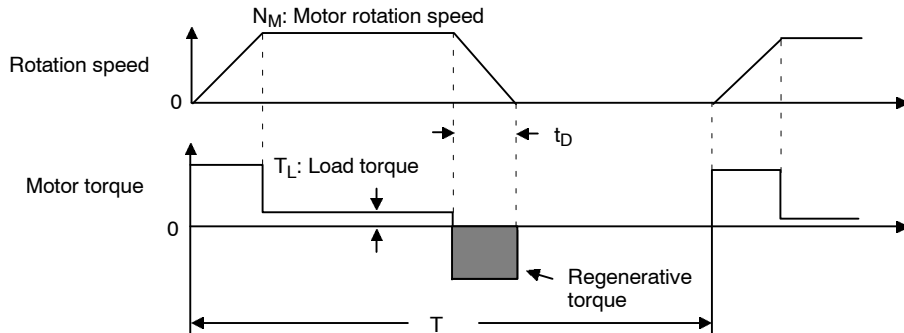

Calculation Procedure

The procedure for calculating the capacity is as follows:

Step	Item	Symbol	Equation
1	Find the rotational energy of the servo system.	E_S	$E_S = JN_M^2/182$
2	Find the energy consumed by load system loss during the deceleration period.	E_L	$E_L = (\pi/60) N_M T_L t_D$
3	Calculate the energy lost from Servomotor winding resistance.	E_M	(Value calculated from “Servomotor Winding Resistance Loss” diagrams) $\times t_D$
4	Calculate the servoamp energy that can be absorbed.	E_C	Calculate from the “Absorbable Servoamp Energy” diagrams.
5	Find the energy consumed by the regenerative resistor.	E_K	$E_K = E_S - (E_L + E_M + E_C)$
6	Calculate the required regenerative resistor capacity.	W_K	$W_K = E_K / (0.2 \times T)$

5

- Note 1.** The “0.2” in the equation for calculating W_K is the value for when the regenerative resistor’s utilized load ratio is 20%.
2. The units for the various symbols are as follows:
 E_S to E_K : Energy joules (J) T_L : Load torque (N·m) (oz·in)
 W_K : Regenerative resistor required capacity (W) t_D : Deceleration stopping time (s)
 J : ($= J_M + J_L$) (kg·m²) (oz·in·s²) T : Servomotor repeat operation period (s)
 N_M : Rotation speed used by Servomotor (r/min)

If the above calculation determines that the amount of regenerative power (W_K) that can be processed by the built-in resistor is not exceeded, then an external regenerative resistor is not required.

If the amount of regenerative power that can be processed by the built-in resistor is exceeded, then install an external regenerative resistor for the capacity obtained from the above calculation.

If the energy consumed by load system loss (in step 2 above) is unknown, then perform the calculation using $E_L = 0$.

When the operation period in regeneration mode is continuous, add the following items to the above calculation procedure in order to find the required capacity (W) for the regenerative resistor.

- Energy for continuous regeneration mode operation period: E_G (joules)
- Energy consumed by regenerative resistor: $E_K = E_S - (E_L + E_M + E_C) + E_G$
- Required capacity of regenerative resistor: $W_K = E_K / (0.2 \times T)$

Here, $E_G = (2\pi/60) N_{MG} T_G t_G$

- T_G : Servomotor’s generated torque (N·m) (oz·in) in continuous regeneration mode operation period
- N_{MG} : Servomotor rotation speed (r/min) for same operation period as above
- t_G : Same operation period (s) as above

Servomotor Winding Resistance Loss

The following diagrams show the relationship, for each Servomotor, between the Servomotor’s generated torque and the winding resistance loss.

1. Servomotor for 100 V

• SGMAH Servomotor, 100 V

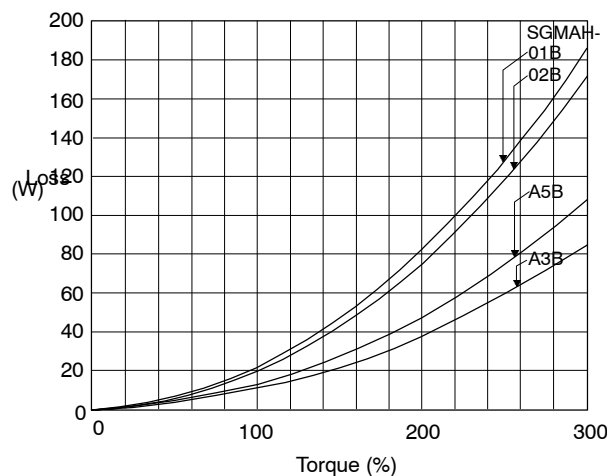

• SGMPH Servomotor, 100 V

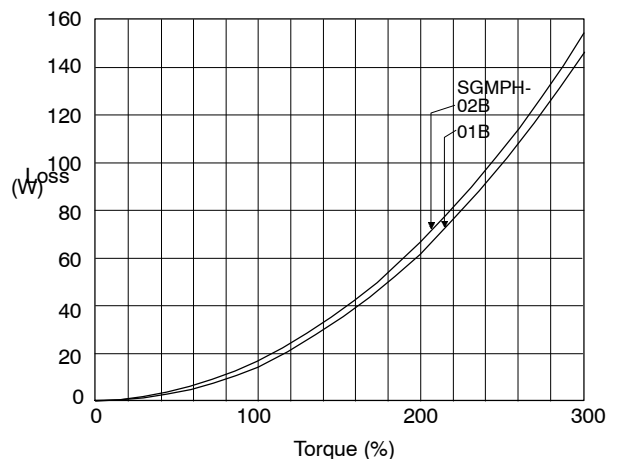

2. Servomotor for 200 V

• SGMAH Servomotor, 200 V

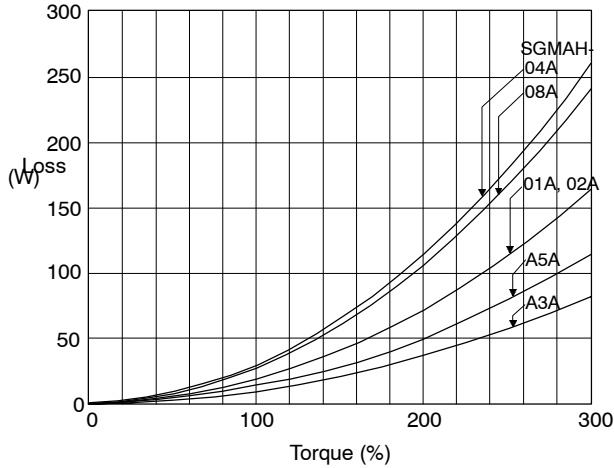

• SGMPH Servomotor, 200 V

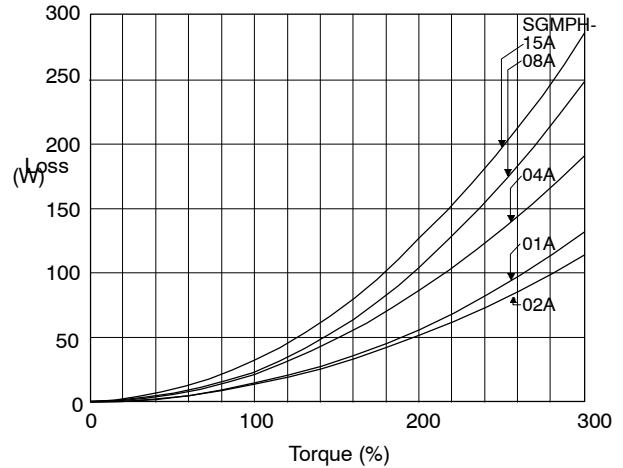

• SGMGH Servomotor, 200 V, 1500 r/min

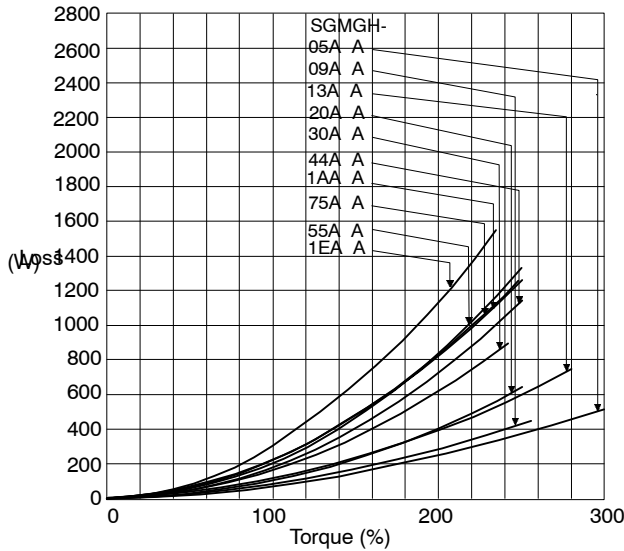

• SGMGH Servomotor, 200 V, 1000 r/min

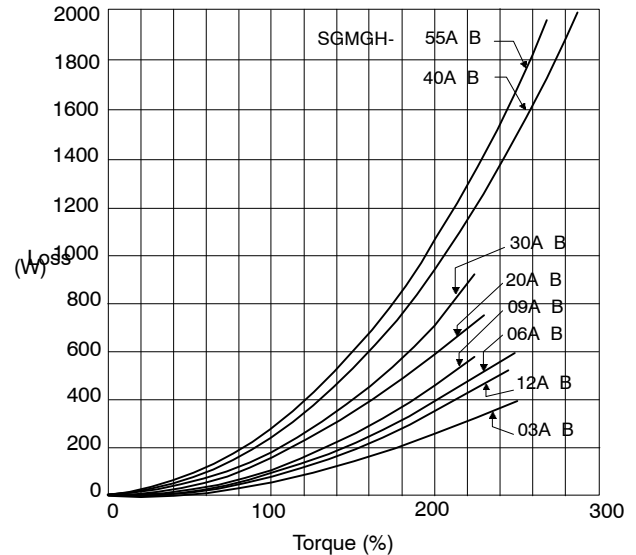

• SGMSH Servomotor, 200 V

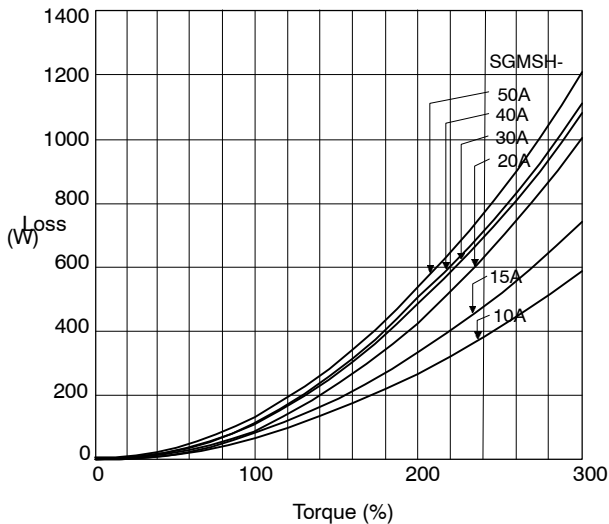

• SGMDH Servomotor, 200 V

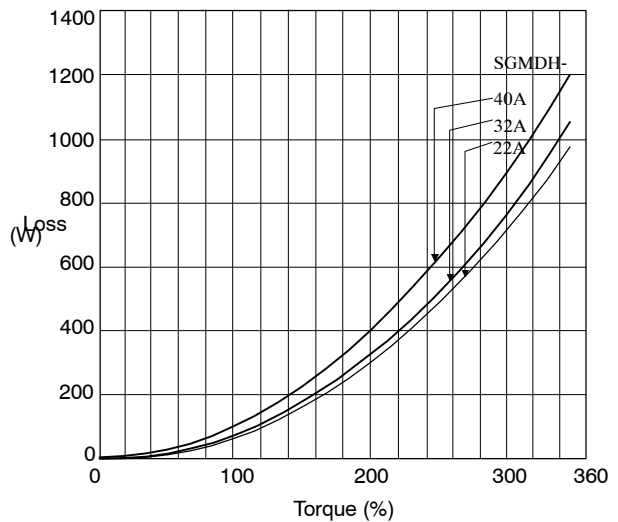

5

3. Servomotor for 400 V

• SGMGH Servomotor, 400 V, 1500 r/min

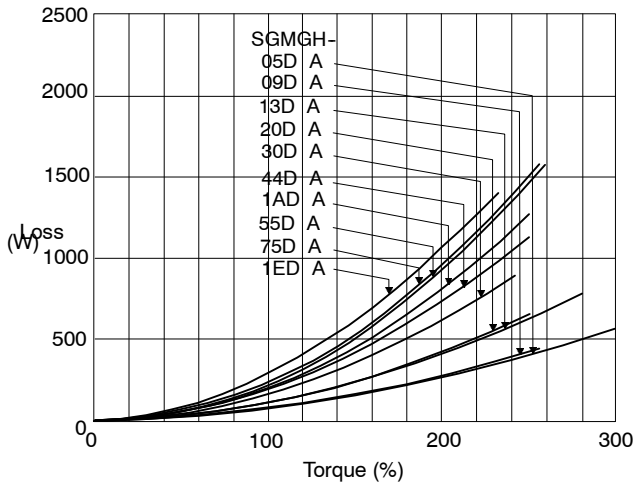

• SGMSH Servomotor, 400 V

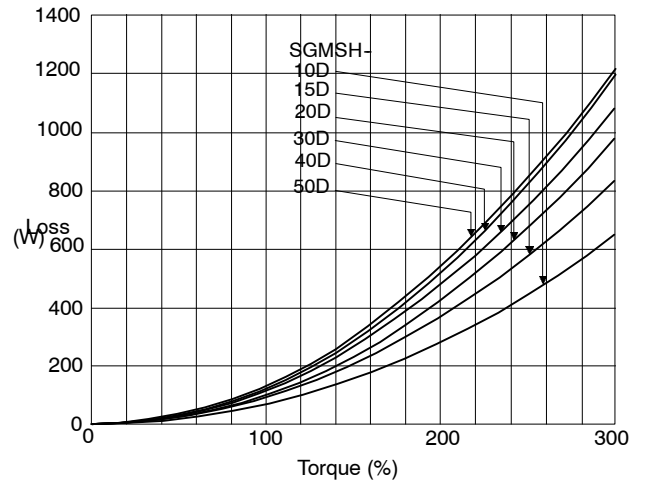

• SGMUH Servomotor, 400 V,

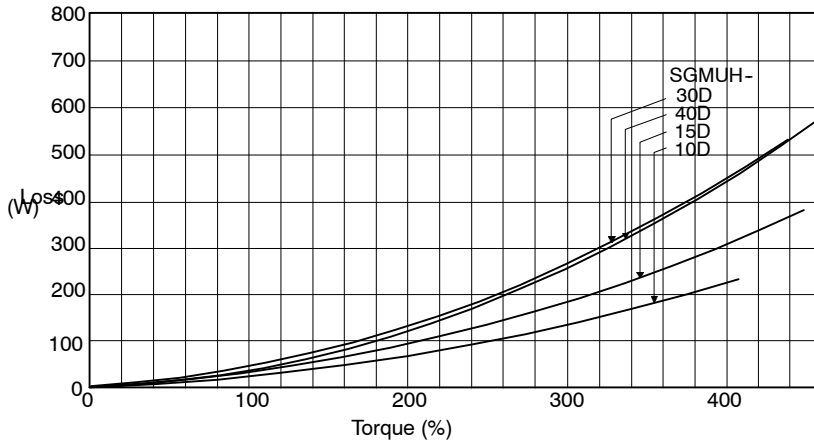

5

Servopack's Absorbable Energy

The following diagrams show the relationship between the Servopack's input power supply voltage and its absorbable energy.

• Servopack for 100 V

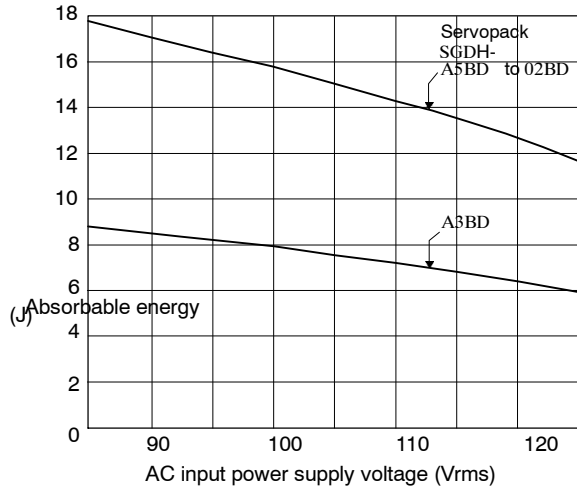

• Servopack for 200 V

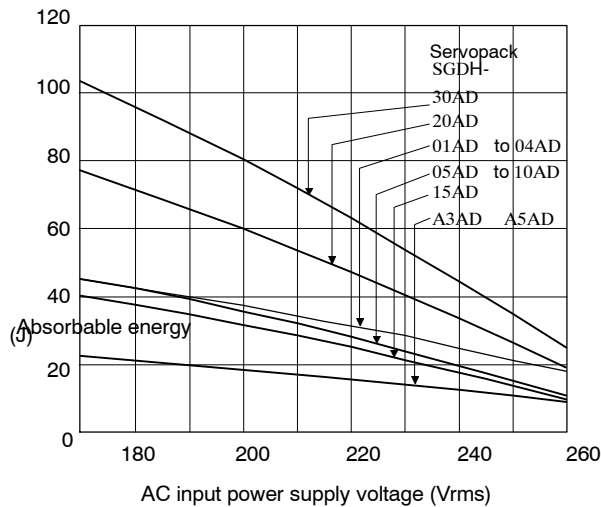

• Servopack for 200 V, Continued

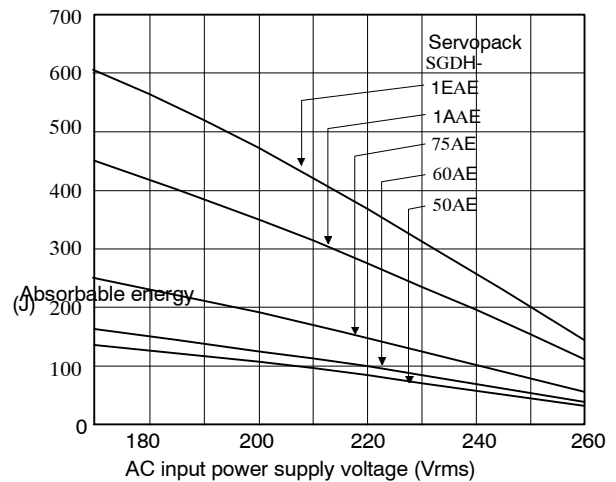

• Servopack for 400 V

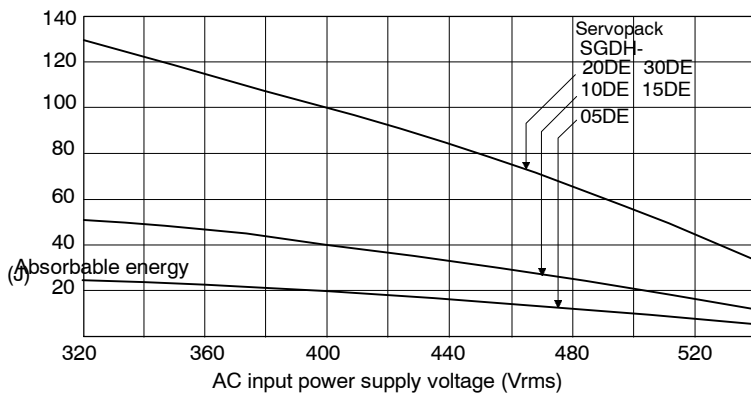

5

- Servopack for 400 V, Continued

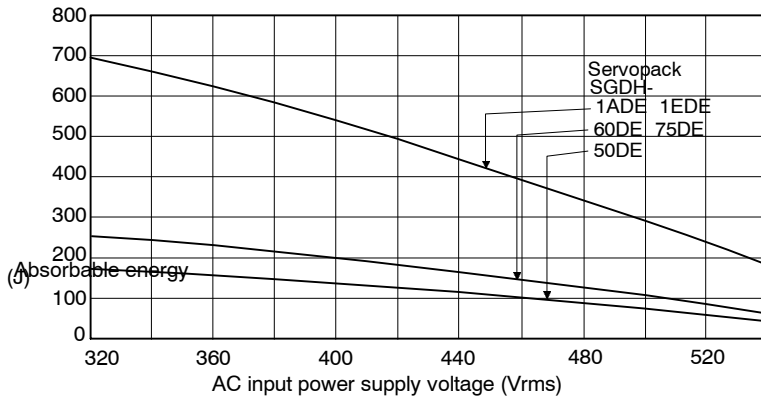

5.7 Absolute Encoders

If a motor with an absolute encoder is used, a system to detect the absolute position can be made in the host controller. If such a system is to be combined with a host controller, use a Servomotor with an absolute encoder. Consequently, operation can be performed without origin return operation immediately after the power is turned ON.

MotorSGM□H-□□□1□...With 16-bit absolute encoder

SGM□H-□□□2□...With 17-bit absolute encoder

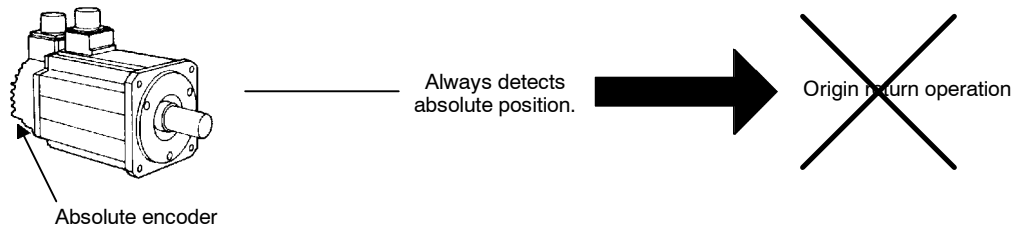

! WARNING

- The output range of multiturn data for □- series absolute detection system differs from that for conventional systems (15-bit encoder and 12-bit encoder). Specially when Infinite length positioning system of conventional type is to be configured with □ - series, be sure to make the following system modification.

Absolute Encoder Type	Output Range of Multiturn Data	Motion When Exceeds the Limit
Conventional Types (12-bit and 15-bit)	-99999 to +99999	<ul style="list-style-type: none"> • When exceeds the upper limit (+99999) in the positive direction, the multiturn data is 0. • When exceeds the lower limit (-99999) in the negative direction, the multiturn data is 0.
□- Series (16-bit and 17-bit)	-32768 to +32767	<ul style="list-style-type: none"> • When exceeds the upper limit (+32767) in the positive direction, the multiturn data is -32768. • When exceeds the lower limit (-32768) in the negative direction, the multiturn data is +32767.*

* When the multiturn limit setting (Pn205) is changed, the motion differs. Refer to 5.7.6 Multiturn Limit Setting.

5.7.1 Interface Circuit

The following diagram shows the standard connections for an absolute encoder mounted to a Servomotor.

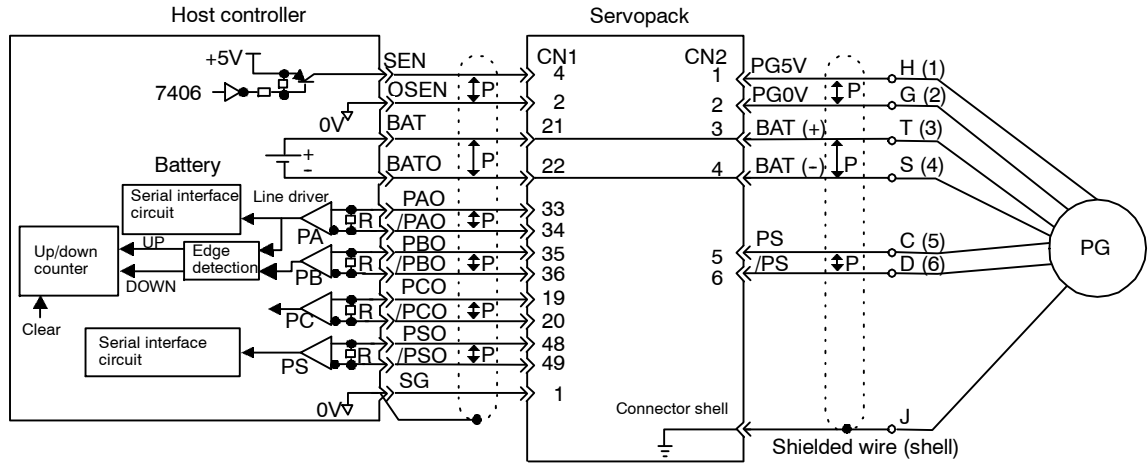

⇕ P: Indicates twisted pair wires.

Applicable line drivers: SN75175 or MC3486 by T/I.

Terminating resistance R:220 to 470 Ω

■ SEN Signals

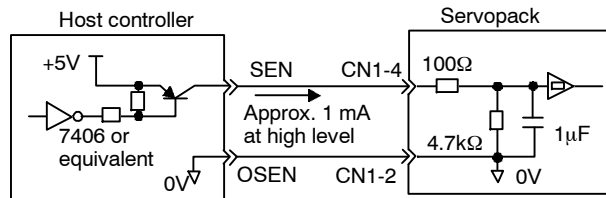

PNP is recommended for transistors.

Signal Levels

High level: 4.0 V min.; Low level: 0.8 V max.

- Let at least three seconds elapse after turning on the power before raising the SEN signal to high level.
- When the SEN signal is changed from low level to high level, the multi-turn data and initial incremental pulses are output.
- Until these operations are completed, the motor cannot be operated regardless of the status of the servo ON signal (/S-ON).

IMPORTANT

If for some reason it is necessary to turn OFF a SEN signal that is already ON, and then to turn it back ON again, maintain the high level for at least 1.3 seconds before turning it ON and OFF.

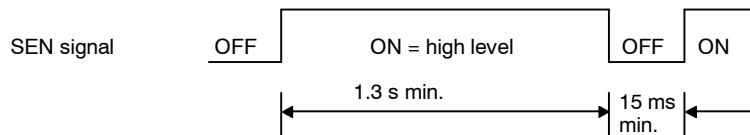

5.7.2 Selecting an Absolute Encoder

Select the absolute encoder usage with the following user constant.

Pn002.2	Absolute Encoder Usage	Factory Setting: 0	Speed, Torque Control, Position Control
----------------	-------------------------------	-------------------------------------	--

“0” in the following table must be set to enable the absolute encoder.

Pn002.2 Setting	Contents
0	Use the absolute encoder as an absolute encoder.
1	Use the absolute encoder as an incremental encoder.

Note This user definition goes into effect when the power is turned OFF after the change has been made.

5.7.3 Handling Batteries

In order for the absolute encoder to retain position data when the power is turned OFF, the data must be backed up by a battery.

■ Installing the Battery at the Host Device

Lithium battery, by Toshiba: ER6VC3, 3.6 V, 2000 mAh

■ Battery Provided for Servopack

Lithium battery: JZSP-BA01 (includes battery and connector)

Battery: Toshiba, ER3 V, 3.6 V, 1000 mAh

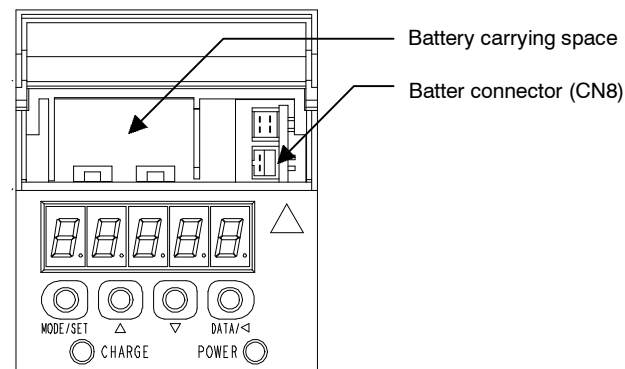

Figure 5.2 Servopacks with Capacities of 30 W to 5.0 kW

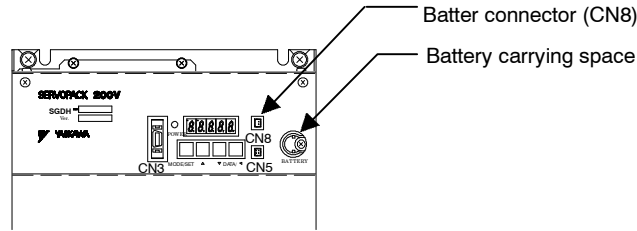

Figure 5.3 Servopacks with Capacities of 6.0 to 15 kW

⊘ PROHIBITED

- Install the battery at either the host controller or the Servopack. It is dangerous to install batteries at both simultaneously, because that sets up a loop circuit between the batteries.

5.7.4 Absolute Encoder Setup

Perform the setup operation for the absolute encoder in the following circumstances:

- When starting the machine for the first time.
- When an encoder backup alarm is generated.
- When the Servopack's power supply is turned OFF and the encoder's cable is removed.

The setup operation can be performed by using the Hand-held Digital Operator or the Servopack's Panel Operator, or else personal computer monitor software can be employed.

The setup operation procedure shown here uses the Digital Operator. For more details, refer to *Chapter 6 Using the Digital Operator*.



The absolute encoder setup operation is only possible when the servo is OFF. After the setup processing is finished, turn the power back ON again.

■ Setup Using the Hand-held Digital Operator

1. Press the DSPL/SET Key to select the auxiliary function mode.

Fn000

2. Select the user constant Fn008. Press the Left or Right Cursor Key to select the digit to set, and then press the Up or Down Cursor Key to change the number.

Fn008

3. Press the DATA/ENTER Key. The following display will appear.

PCL1

- Pressing the Up Cursor Key will change the display as shown below. Continue pressing the Up Cursor Key until “PGCL5” is displayed. If an erroneous key entry is made, “nO_OP” will flash for one second and the display will return to the auxiliary function mode. In that case, go back to step 3 above and perform the operation again.

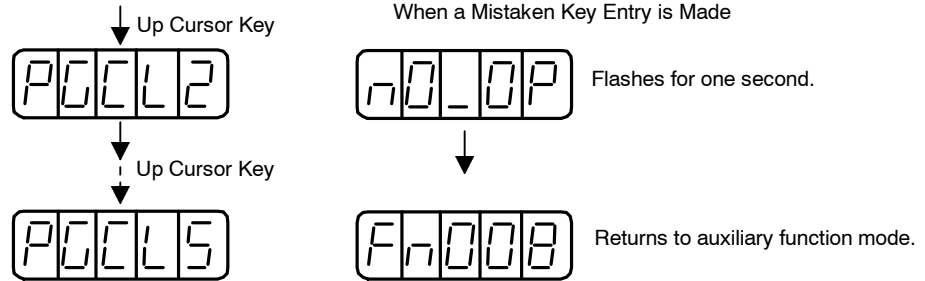

- When “PGCL5” is displayed, press the DSPL/SET Key. The display will change as follows, and the absolute encoder’s multi-turn data will be cleared.

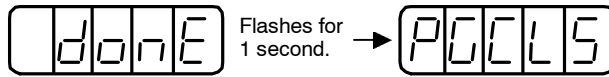

- Press the DATA/ENTER Key to return to the auxiliary function mode.



This completes the absolute encoder’s setup operation. Turn the power OFF and then back ON again.

■ Setup Using the Built-in Panel Operator

- Press the DSPL/SET Key to select the auxiliary function mode.



- Press the Up or Down Cursor Key to select the user constant Fn008.

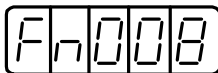

- Press the DATA/SHIFT Key for at least one second. The following display will appear.

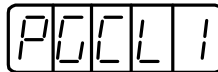

- Pressing the Up Cursor Key will change the display as shown below. Continue pressing the Up Cursor Key until “PGCL5” is displayed. If an erroneous key entry is made, “nO_OP” will flash for one second and the display will return to the auxiliary function mode. In that case, go back to step 3 above and perform the operation again.

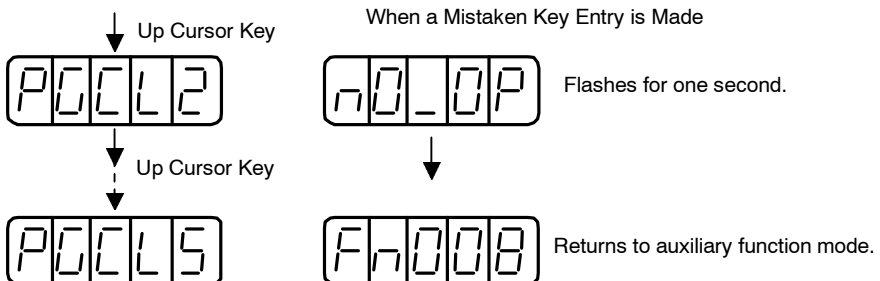

5. When “PGCL5” is displayed, press the MODE/SET Key. The display will change as follows, and the absolute encoder’s multi-turn data will be cleared.

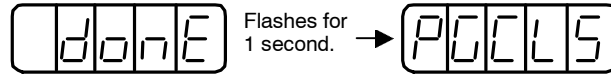

6. Press the DATA/SHIFT Key to return to the auxiliary function mode.



This completes the absolute encoder’s setup operation. Turn the power OFF and then back ON again.

IMPORTANT

If the following absolute encoder alarms are displayed, the alarms must be cleared using the method described above for the setup operation. They cannot be cleared by the Servopack’s alarm reset (/ARM-RST) input signal.

- Encoder backup alarm (A.81)
- Encoder sum check alarm (A.82)

In addition, if a monitoring alarm is generated in the encoder, the alarm must be cleared by turning OFF the power.

5.7.5 Absolute Encoder Reception Sequence

The sequence in which the Servopack receives outputs from the absolute encoder and transmits them to the host device is shown below.

Be sure you understand this section when designing the host device.

■ Outline of Absolute Signals

The absolute encoder’s outputs are PAO, PBO, PCO, and PSO signals as shown below.

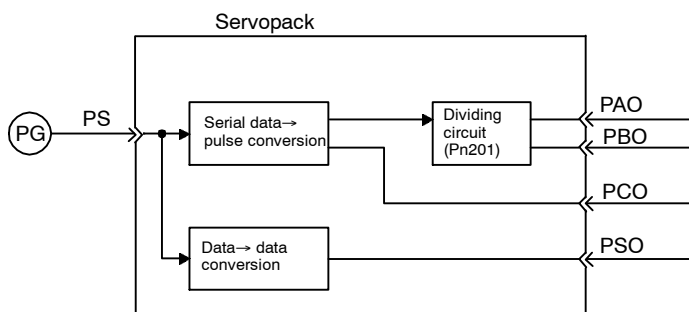

Signal Name	Status	Signal Contents
PAO	Initial state	Serial data Initial incremental pulse
	Normal state	Incremental pulse
PBO	Initial state	Initial incremental pulse
	Normal state	Incremental pulse
PCO	Normal state	Origin pulse
PSO	Normal state	Rotation count serial data

■ Contents of Absolute Data

- Serial data: Indicates how many turns the motor shaft has made from the reference position (position specified at setup).
- Initial incremental pulse: Outputs pulses at the same pulse rate as when the motor shaft rotates from the origin to the current position at approximately 2500 r/min (for 16 bits when the dividing pulse is at the factory setting)

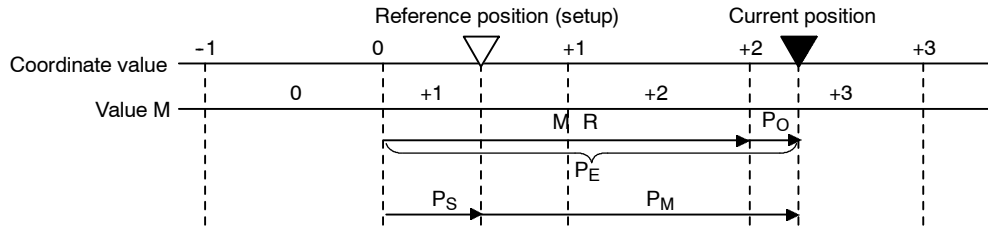

The final absolute data P_M can be found by using the following formula.

$$P_E = M \times R + P_O$$

$$P_M = P_E - P_S$$

Use the following for reverse rotation mode ($Pn000.0 = 1$).
 $P_E = -M \times R + P_O$
 $P_M = P_E - R_S$

P_E	Current value read by encoder
M	Multi-turn data (rotation count data)
P_O	Number of initial incremental pulses
P_S	Number of initial incremental pulses read at setup (This is saved and controlled by the host controller.)
P_M	Current value required for the user's system.
R	Number of pulses per encoder revolution (pulse count after dividing, value of Pn201)

■ Absolute Encoder Transmission Sequence

1. Set the SEN signal at high level.
2. After 100 ms, set the system to serial data reception-waiting-state. Clear the incremental pulse up/down counter to zero.
3. Receive eight bytes of serial data.
4. The system enters a normal incremental operation state approximately 50 ms after the last serial data is received.

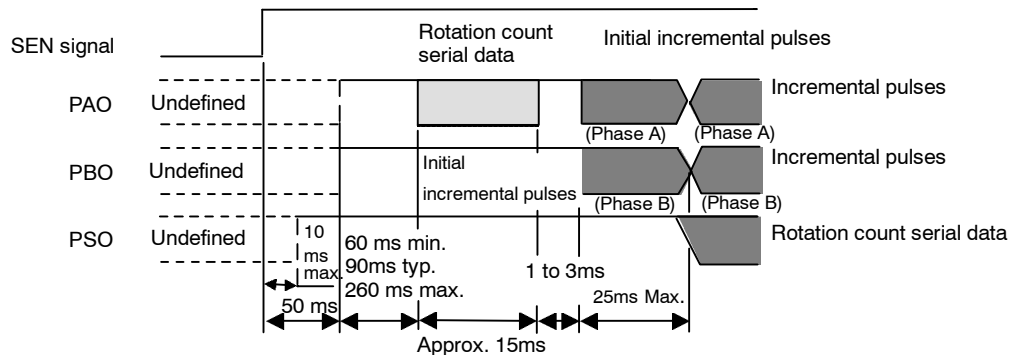

5

■ Detailed Signal Specifications

PAO Serial Data Specifications

The number of revolutions is output in five digits.

Data Transfer Method	Start-stop Synchronization (ASYNC)
Baud rate	9600 bps
Start bits	1 bit
Stop bits	1 bit
Parity	Even
Character code	ASCII 7-bit code
Data format	8 characters, as shown below.

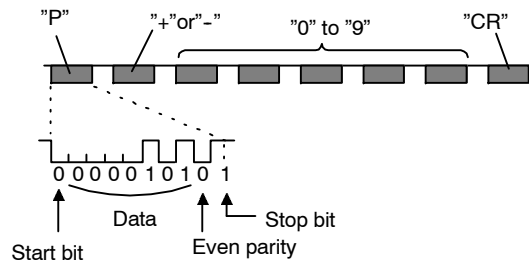

Note 1. Data is "P+00000" (CR) or "P-00000" (CR) when the number of revolutions is zero.

2. The revolution range is "+32767" to "-32768." When this range is exceeded, the data changes from "+32767" to "-32768" or from "-32768" to "+32767." When changing multiturn limit, the range changes. For details, see 5.7.6 *Multiturn Limit Setting*.

PSO Serial Data Specifications

The number of revolutions and the absolute position within one revolution are always output in five and 7 digits, respectively. The data output cycle is approximately 40 ms.

Data Transmission Method	Start-stop Synchronization (ASYNC)
Baud rate	9600 bps
Start bits	1 bit
Stop bits	1 bit
Parity	Even
Character code	ASCII 7-bit code
Data format	13 characters, as shown below.

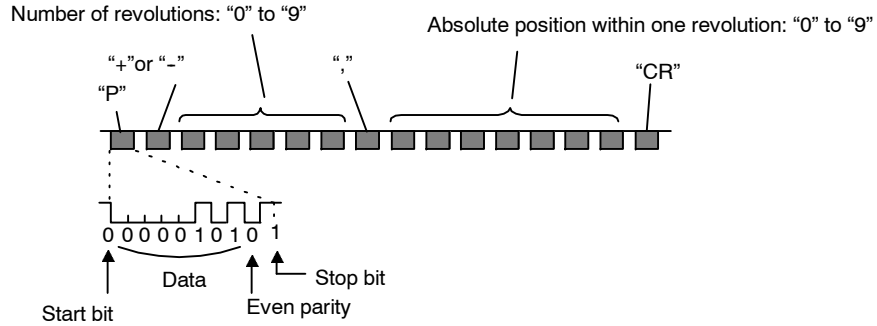

- Note 1.** The absolute position data within one revolution is the value before dividing.
 2. Absolute position data increases during forward rotation. (Not valid in reverse rotation mode.)

Incremental Pulses and Origin Pulses

Just as with normal incremental pulses, initial incremental pulses which provide absolute data are first divided by the frequency divider inside the Servopack and then output.

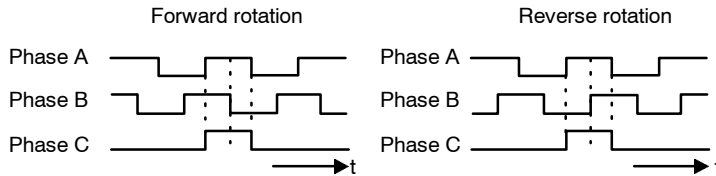

Setting the Pulse Dividing Ratio

Use the following user constant to set the pulse dividing ratio.

Pn201	PG Divider	Unit: P/R	Setting Range: 16 to 16384	Factory Setting: 16384	Speed/Torque Control, Position Control
-------	------------	--------------	----------------------------------	------------------------------	--

This user constant sets the number of output pulses for PG output signals (PAO, /PAO, PBO, /PBO) sent externally.

Pulses from the motor encoder (PG) are divided by the number of pulses set here before being output.

The set value is the number of output pulses per revolution. Set this value according to the reference unit of the machine or controller to be used.

The setting range varies according to the encoder used.

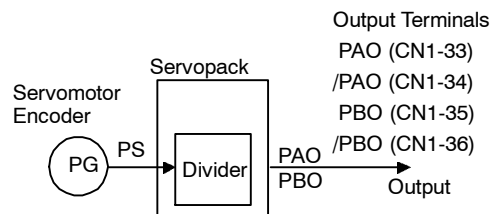

Setting Example

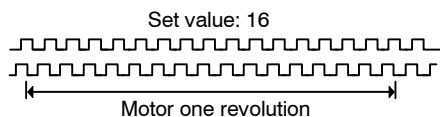

5

■ Transferring Alarm Contents

When an absolute encoder is used, SEN signals can be utilized to transfer the alarm detection contents from PAO outputs to the host device as serial data.

Table 5.1 Alarm Contents Output Example

SEN Signal		
Digital Operator Display		
PAO Serial Data	<p>Incremental pulses</p>	ALM81

Refer to 7.2.3 *Alarm Display Table* for a table of alarm contents.

5.7.6 Multiturn Limit Setting

When implementing absolute detection systems for machines that turn m times in response to n turns in the load shaft, such as round tables, it is convenient to reset the multiturn data from the encoder to 0 every m turns. The Multiturn Limit Setting allows the value m to be set for the encoder.

The use of an absolute encoder can be specified by setting the following user constant.

Pn002.2	Absolute Encoder Usage	Factory Setting: 0	Speed/Torque Control, Position Control
----------------	-------------------------------	------------------------------	---

“0” in the following table must be set in order to enable the absolute encoder.

Pn002.2 Setting	Contents
0	Use the absolute encoder as an absolute encoder.
1	Use the absolute encoder as an incremental encoder.

The multiturn limit is set in the Servopack using the following user constant.



◆ Multiturn limit

The multiturn limit is the upper limit of the multiturn data. If Pn002.2 = 0, the multiturn data will vary between 0 and the value set for Pn205 (Multiturn Limit Setting).

Pn205	Multiturn Limit Setting	Unit: rev	Setting Range: 0 to 65535	Factory Setting: 65535	Speed/Torque Control, Position Control
--------------	--------------------------------	---------------------	-------------------------------------	----------------------------------	---

If the Multiturn Limit Setting is set to 65535 (factory setting), the multiturn data will vary from -32768 to 32767. If any other value is set, the multiturn data will vary from 0 to the setting of Pn205.

- Variation of multiturn data when the multiturn limit value is 65535 (factory setting).

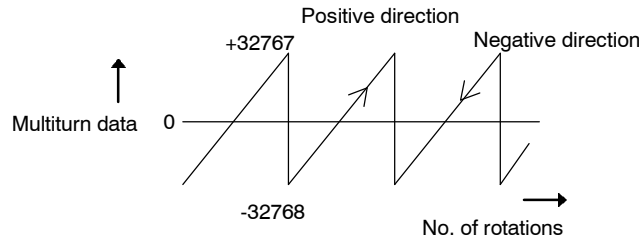

- Variation of multiturn data when the multiturn limit value is other than 65535 (factory setting).

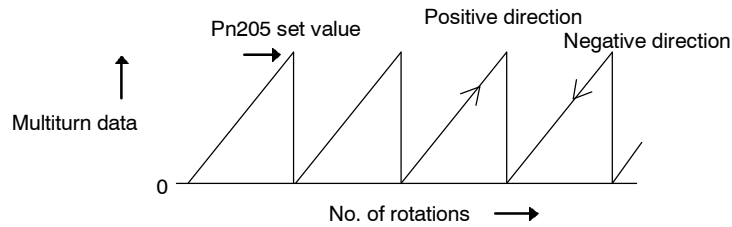

If the Servomotor rotates in the negative direction from 0, the multiturn data will change to the value set for Pn205. If the Servomotor rotates in the positive direction from the value set in Pn205, the multiturn data will change to 0. Set Pn205 to $m - 1$.



Turn the power OFF and then back ON after changing the setting of user constant Pn002.2 or Pn205.

The multiturn limit value in the Encoder is factory set to 65535, the same as the Servopack. If the multiturn limit value in the Servopack is changed with Pn205 and then the Servopack power is turned OFF and ON, the following alarm will occur.

Alarm Name: Multiturn Limit Disagreement

Alarm Display	Alarm Code Outputs			Meaning of Alarm
	ALO1	ALO2	ALO3	
A.CC	ON	OFF	ON	The multiturn limit value is different in the Encoder and Servopack.

Note ON signals are low level; OFF signals are high level.

When this alarm occurs, the multiturn limit in the Encoder must be changed. The auxiliary function mode of the Digital Operator is used to change this setting. It can also be set from a personal computer using the Monitor Software.

The procedure to set the multiturn limit in the Encoder using the Digital Operation is provided next. Refer also to *Chapter 6 Using the Digital Operator*.



The multiturn limit setting in the Encoder can be changed only when the Multiturn Limit Disagreement alarm has occurred. After changing the setting, turn the power supply OFF and then back ON.

■ Changing the Setting with the Hand-held Digital Operator

1. Press the DSPL/SET Key to select the auxiliary function mode.

2. Select the user function Fn013. Press the Left or Right Cursor Key to select the digit to set, and then press the Up or Down Cursor Key to change the number.

3. Press the DATA/ENTER Key. The following display will appear.

4. Press the DSPL/SET Key. The following display will appear and the multiturn limit setting in the absolute encoder will be changed.

5. Press the DATA/ENTER Key to return to the auxiliary function mode.

This completes the procedure to change the multiturn limit setting in the absolute encoder. Turn the power supply OFF and then back ON.

■ Changing the Setting with the Built-in Panel Operator

1. Press the DSPL/SET Key to select the auxiliary function mode.

2. Press the Up or Down Cursor Key to select the user constant Fn013.

3. Press the DATA/SHIFT Key for at least one second. The following display will appear.

4. Press the MODE/SET Key. The following display will appear and the multiturn limit setting in the absolute encoder will be changed.

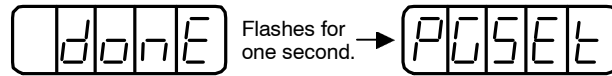

5. Press the DATA/SHIFT Key for at least one second to return to the auxiliary function mode.



This completes the procedure to change the multiturn limit setting in the absolute encoder. Turn the power supply OFF and then back ON.

⚠ WARNING The multiturn limit value must be changed only for special applications. Changing it inappropriately or unintentionally can be dangerous.

⚠ WARNING If the Multiturn Limit Disagreement alarm occurs, check the setting of user constant Pn205 in the Servopack to be sure that it is correct. If Fn013 is executed when an incorrect value is set in Pn205, an incorrect value will be set in the Encoder. The alarm will disappear even if an incorrect value is set, but incorrect positions will be detected, resulting a dangerous situation where the machine will move to unexpected positions.

5.8 Special Wiring

This section describes special wiring methods including the one for noise control. In addition to 5.8.1 *Wiring Precautions* and 5.8.2 *Wiring for Noise Control*, refer to other sections as necessary.

5.8.1 Wiring Precautions

To ensure safe and stable operation, always observe the following wiring precautions.

IMPORTANT

1. Always use the following cables for reference input and encoder wiring.

-	Cable Type	Yaskawa Drawing No.	Maximum Allowable Length
Reference Input	Twisted-pair wires	JZSP-CKI01	3 m (118 in)
Encoder	Multiconductor shielded twisted-pair wire	JZSP-CMP09	20 m (787 in)
		JZSP-CMP19	50 m (1969 in)

- Trim off the excess portion of the cable to minimize the cable length.
2. For a ground wire, use as thick a cable as possible (2.0 mm² or thicker).



- At least class-3 ground (100 Ω max.) is recommended.
 - Ground to one point only.
 - If the motor is insulated from the machine, ground the motor directly.
3. Do not bend or apply tension to cables.
The conductor of a signal cable is very thin (0.2 to 0.3 mm (0.0079 to 0.012 in)), so handle the cables with care.
 4. Use a noise filter to prevent noise interference.
(For details, refer to 5.8.2 *Wiring for Noise Control*.)
 - If the equipment is to be used near private houses or may receive noise interference, install a noise filter on the input side of the power supply line.
 - Since this Servopack is designed as an industrial device, it provides no mechanism to prevent noise interference.

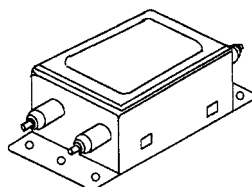

5. To prevent malfunction due to noise, take the following actions:

- Position the input reference device and noise filter as close to the Servopack as possible.
- Always install a surge absorber circuit in the relay, solenoid and electromagnetic contactor coils.
- The distance between a power line (such as a power supply line or motor cable) and a signal line must be at least 30 cm. Do not put the power and signal lines in the same duct or bundle them together.
- Do not share the power supply with an electric welder or electrical discharge machine. When the Servopack is placed near a high-frequency oscillator, install a noise filter on the input side of the power supply line.

Note 1. Since the Servopack uses high-speed switching elements, signal lines may receive noise. To prevent this, always take the above actions.

2. For details on grounding and noise filters, refer to *5.8.2 Wiring for Noise Control*.

6. Use a molded-case circuit breaker (QF) or fuse to protect the power supply line from high voltage.

- This Servopack connects directly to a commercial power supply without a transformer, so always use an QF or fuse to protect the servo system from accidental high voltage.
- Select an appropriate QF or fuse according to the Servopack capacity and the number of Servopacks to be used as shown in the following table.

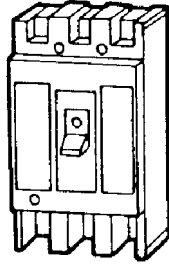

■ QF or Fuse According to Power Capacity

The following table shows the QF or fuse capacity for each power supply capacity.

Main Circuit Power Supply	Servopack Model		Applicable Motor	Power Capacity per Servopack (kVA) *1	Current Capacity per QF or Fuse (A _{Rms}) *1,*2
	Capacity (kW)	SGDH-			
Single-phase: 100 V	0.03	A3BE	SGMAH-A3B	0.15	4
	0.05	A5BE	SGMAH-A5B	0.25	
	0.10	01BE	SGMAH-01B SGMPH-01B	0.40	
	0.20	02BE	SGMAH-02B	0.60	6
			SGMPH-02B		
Single-phase: 200 V	0.03	A3AE	SGMAH-A3A	0.20	4
	0.05	A5AE	SGMAH-A5A	0.25	
	0.10	01AE	SGMAH-01A	0.40	
			SGMPH-01A		
	0.20	02AE	SGMAH-02A	0.75	
			SGMPH-02A		
	0.40	04AE	SGMAH-04A	1.2	8
			SGMPH-04A		
0.75	08AE-S	SGMAH-08A	2.1	11	
		SGMPH-08A			
1.50	15AE-S	SGMPH-15A	4.0	19	
Three-phase: 200 V	0.45	05AE	SGMGH-05A A	1.4	4
			SGMGH-03A B		
	0.75	08AE	SGMAH-08A	1.9	7
			SGMPH-08A		
			SGMGH-06A B		
	1.0	10AE	SGMGH-09A□A	2.3	
			SGMGH-09A□B		
			SGMSH-10A		
	1.5	15AE	SGMPH-15A	3.2	10
			SGMGH-13A□A		
			SGMGH-12A□B		
	2.0	20AE	SGMSH-15A	4.3	13
			SGMGH-20A□A		
			SGMGH-20A□B		
	3.0	30AE	SGMDH-22A	5.9	17
SGMGH-30A□A					
SGMGH-30A□B					
5.0	50AE	SGMSH-30A	7.5	28	
		SGMDH-32A			
		SGMDH-40A			
		SGMSH-40A			
		SGMGH-44A□A			
6.0	60AE	SGMGH-40A□B	12.5	32	
		SGMSH-50A			
7.5	75AE	SGMGH-75A□A	15.5	41	

Main Circuit Power Supply	Servopack Model		Applicable Motor	Power Capacity per Servopack (kVA) *1	Current Capacity per QF or Fuse (A _{rms}) *1,*2
	Capacity (kW)	SGDH-			
Three-phase: 200 V	11.0	1AAE	SGMGH-1AA	22.7	60
	15.0	1EAE	SGMGH-1EA	30.9	81
Three-phase: 400 V	0.45	05DE	SGMGH-05D	1.1	1.6
	1.0	10DE	SGMGH-09D	2.3	3.4
			SGMSH-10D		
			SGMUH-10D		
	1.5	15DE	SGMGH-13D	3.2	4.6
			SGMSH-15D		
			SGMUH-15D		
	2.0	20DE	SGMGH-20D	4.9	7.1
			SGMSH-20D		
	3.0	30DE	SGMGH-30D	6.7	9.7
			SGMSH-30D		
			SGMUH-30D		
	5.0	50DE	SGMGH-44D□A	10.3	14.9
			SGMSH-40D□A		
			SGMSH-50D□A		
SGMUH-40D□A					
6.0	60DE	SGMGH-55D□A	12.4	17.8	
7.5	75DE	SGMGH-75D□A	15.4	22.3	
11.0	1ADE	SGMGH-1AD□A	22.6	32.7	
15.0	1EDE	SGMGH-1ED□A	30.9	44.6	

* 1. This is the net value at the rated load. When actually selecting fuses, determine the capacity using the prescribed derating.

* 2. Operating characteristics (at 25°C): 2 seconds or more for 200%, 0.01 second or more for 700%

Note A fast-operating fuse cannot be used because the Servopack power supply is a capacitor input type. A fast-operating fuse may blow out when the power is turned ON.

IMPORTANT

SGDH Servopacks do not have built-in ground protection circuits. To configure a safer system, install an earth leakage breaker for protection against overloads and short-circuiting, or else install an earth leakage breaker for ground protection in combination with a wiring circuit breaker.

5.8.2 Wiring for Noise Control

■ Wiring Example

This Servopack uses high-speed switching elements in the main circuit. It may receive “switching noise” from these high-speed switching elements if wiring or grounding around the Servopack is not appropriate. To prevent this, always wire and ground the Servopack correctly.

This Servopack has a built-in microprocessor (CPU), so it is necessary to protect it from external noise as much as possible by installing a noise filter in the appropriate place.

The following is an example of wiring for noise control.

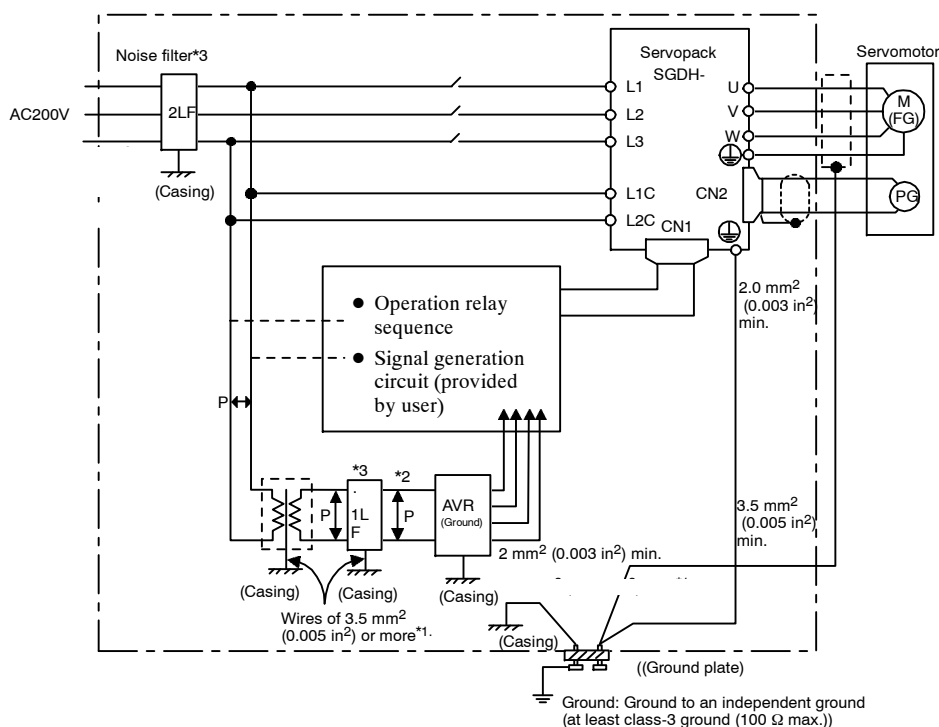

Note 1. For ground wires connected to the casing, use a thick wire with a thickness of at least 3.5 mm² (0.005 in²) (preferably, plain stitch cooper wire).

2. For wires indicated by P use twisted-pair wires whenever possible.

3. When using a noise filter, follow the precautions in ■ *Using Noise Filters*.

■ Correct Grounding

Grounding the Motor Frame

Always connect servomotor frame terminal FG to the Servopack ground terminal \oplus . Also be sure to ground the ground terminal \oplus .

If the servomotor is grounded via the machine, a switching noise current will flow from the Servopack power unit through motor stray capacitance. The above grounding is required to prevent the adverse effects of switching noise.

Noise on the Reference Input Line

If the reference input line receives noise, ground the 0 V line (SG) of the reference input line. If the main circuit wiring for the motor is accommodated in a metal conduit, ground the conduit and its junction box. For all grounding, ground at one point only.

All grounds must be made to only one point in the system.

■ Using Noise Filters

Use an inhibit type noise filter to prevent noise from the power supply line. The following table lists recommended noise filters for each Servopack model.

Install a noise filter on the power supply line for peripheral equipment as necessary.

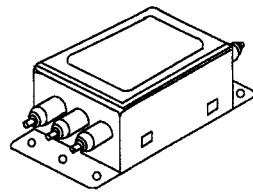

Table 5.2 Noise Filters

Voltage	Servopack Model	Recommended Noise Filter		
		Model	Manufacturer	
Single-phase 100 V	SGDH-A3BE to -01BE	FN2070-6/07	SCHAFFNER	
	SGDH-02BE	FN2070-10/07		
Single-phase 200 V	SGDH-A3AE to -02AE	FN2070-6/07		
	SGDH-04AE	FN2070-10/07		
	SGDH-08AE-S	FN2070-16/07		
	SGDH-15AE-S	FN350-30/33		
Three-phase 200 V	SGDH-05AE to -20AE	FN258L-7/07		TIMONTA
	SGDH-30AE	FN258L-30/07		
	SGDH-50AE, -60AE	FNAC0934-5010		
	SGDH-75AE	FNAC0934-6410		
	SGDH-1AAE, -1EAE	FS5559-150-35	SCHAFFNER	

Voltage	Servopack Model	Recommended Noise Filter	
		Model	Manufacturer
Three-phase 400 V	SGDH-05DE to -15DE	FN258L-7/07	SCHAFFNER
	SGDH-20DE, -30DE	FN258L-16/07	
	SGDH-50DE to -75DE	FS5559-35-	
	SGDH-1ADE, -1EDE	FS5559-80-34	

Note These noise filters are manufactured by Tokin Corp. and available from Yaskawa. For noise filters, contact your nearest Yaskawa representatives.

Always observe the following installation and wiring instructions. Incorrect use of a noise filter halves its benefits.

- Separate input lines from output lines.

Do not put the input and output lines in the same duct or bundle them together.

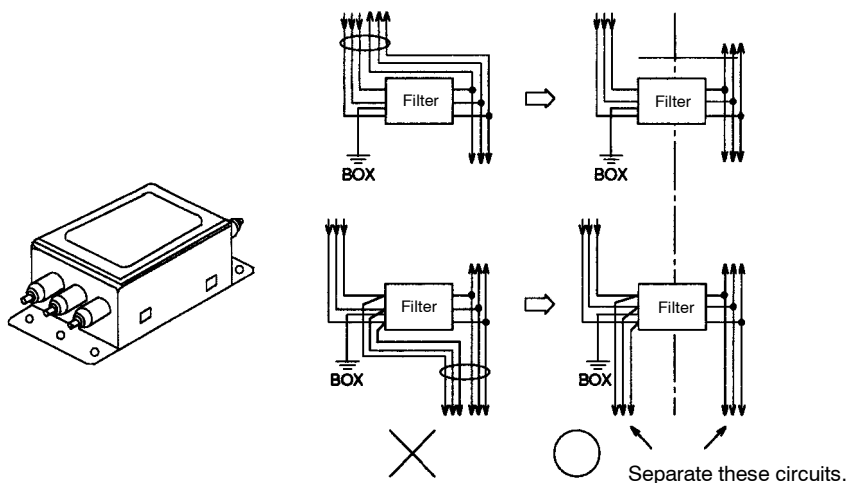

- Separate the noise filter ground wire from the output lines.

Do not accommodate the noise filter ground wire, output lines and other signal lines in the same duct or bundle them together.

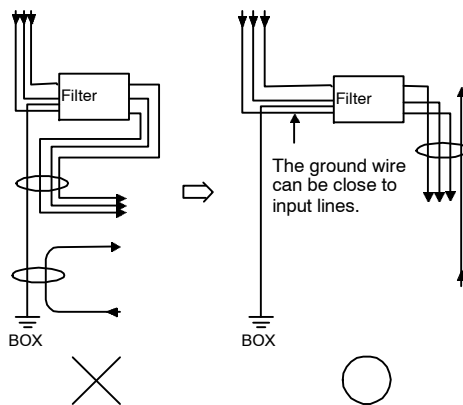

- Connect the noise filter ground wire directly to the ground plate.
Do not connect the noise filter ground wire to other ground wires.

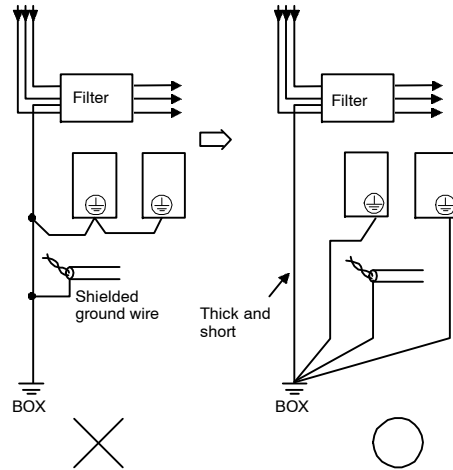

- When grounding a noise filter inside a Unit.

If a noise filter is located inside a Unit, connect the noise filter ground wire and the ground wires from other devices inside the Unit to the ground plate for the Unit first, then ground these wires.

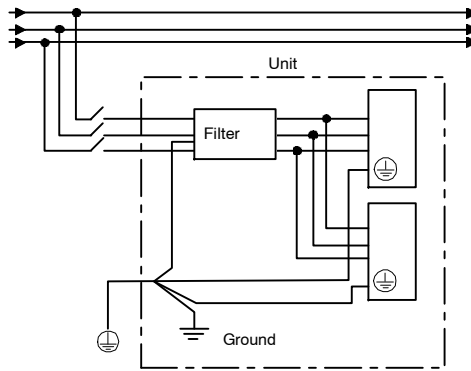

5

5.8.3 Using More Than One Servodrive

The following diagram is an example of the wiring when more than Servodrive is used.

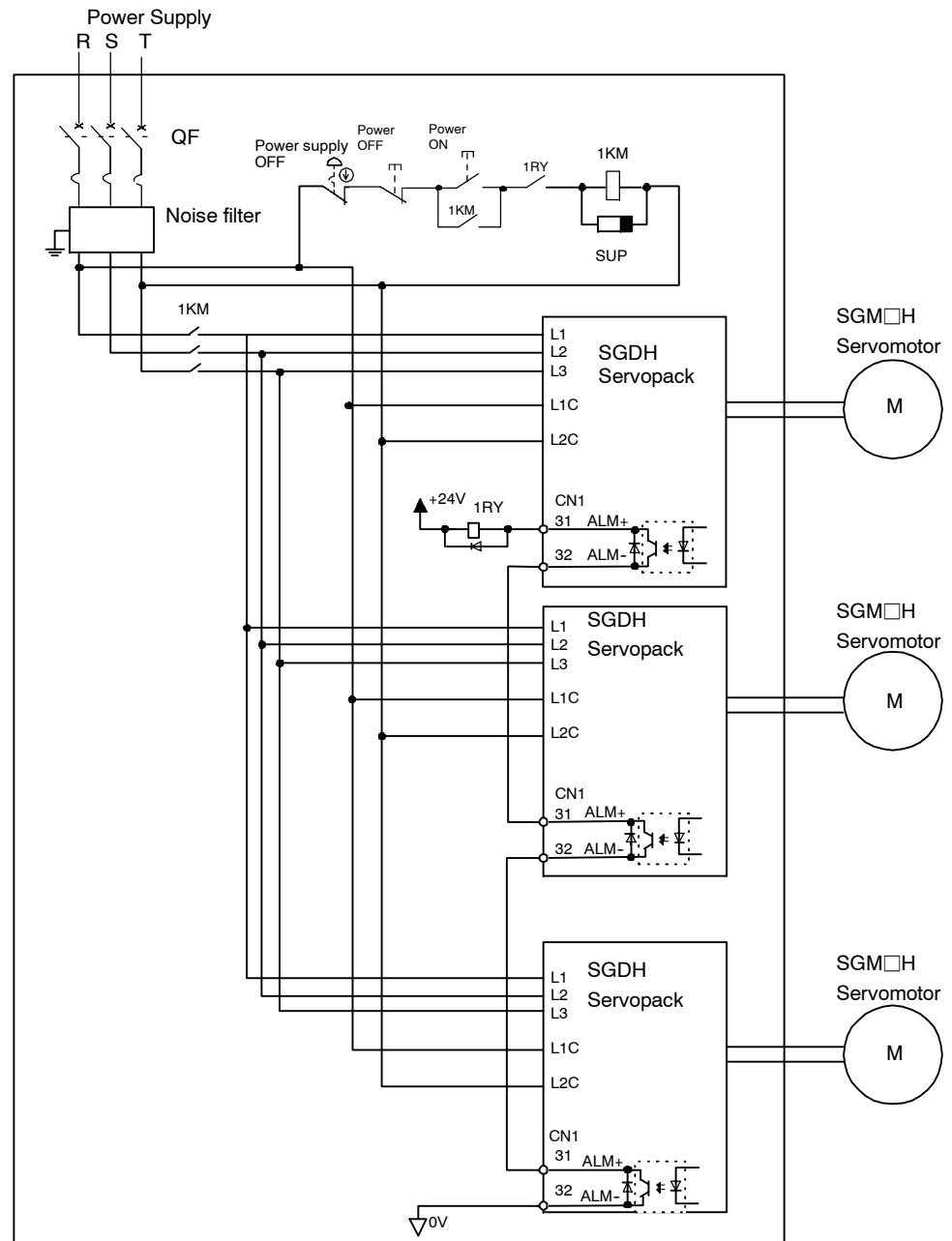

Note Wire the system so that the power supply's S phase is the ground.

Connect the alarm output (ALM) terminals for the three Servopacks in series to enable alarm detection relay 1RY to operate.

The output transistor is turned OFF when the ALM output signal invokes the alarm state.

Multiple servos can share a single QF or noise filter. Always select a QF or noise filter that has enough capacity for the total power capacity (load conditions) of those servos. For details, refer to 5.8.1 *Wiring Precautions*.

5.8.4 Extending Encoder Cables

Standard encoder cables have a maximum length of 20 m. If a longer cable is required, prepare an extension cable as described below. The maximum allowable cable length is 50 m.

For more details, refer to the Σ -II Series SGM□H/SGDH User's Manual: Servo Selection and Data Sheets (SIE-S800-32.1).

Preparing 50-m (1968.50 in) Encoder Cables

- Cable Lines

Length	Cable Line Model Numbers
30 m (1181.10 in)	JZSP-CMP19-30
40 m (1574.80 in)	JZSP-CMP19-40
50 m (1968.50 in)	JZSP-CMP19-50

When specifying the cable length, just specify the model number: JZSP-CMP19-□. The □ in the model number designates the length of the cable (in meters).

EXAMPLE

For example, to order 35-m cable, specify JZSP-CMP19-35 as the model number.

- Connectors or Connector Kits

Type		Model
Servopack end	Encoder connector (CN2) socket	JZSP-CMP9-1
Servomotor end	Encoder connector socket for SGMAH and SGMPH Servomotors	JZSP-CMP9-2
	Encoder connector plug and cable plug for SGMGH, SGMSH, SGMDH and SGMUH Servomotors	Plug L: MS3108B20-29S Straight: MS3106B20-29S Cable clamp: MS3057-12A

● Preparing Encoder Cables

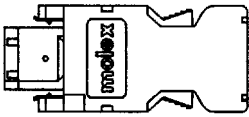
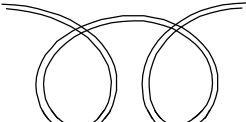
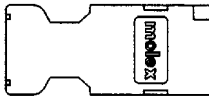
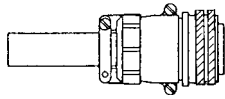
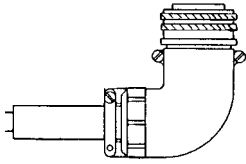
• Encoder Connector at Servopack	• Cable Line	• Encoder Connector at Servomotor	
 <p>(JZSP-CMP9-1)</p>	 <p>(JZSP-CMP19-□)</p>		For SGMAH and SGMPH Servomotors
			For SGMGH, SGMSH, SGMDH and SGMUH Servomotors
			

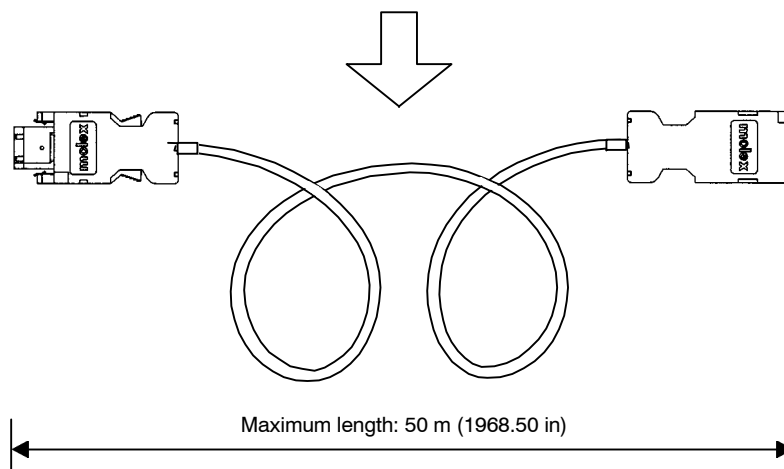

5.8.5 400-V Power Supply Voltage

CAUTION

- Do not connect the Servopack for 100 V and 200 V directly to a voltage of 400 V. The Servopack will be destroyed.

There are four types of SGDH Servopacks, for the power supply voltages: Single-phase 100 VAC, single-phase 200 VAC, three-phase 200 VAC, and three-phase 400 VAC. When using the Servopack for 100 V or 200 V with the three-phase 400-VAC class (380 V to 480 V), prepare the following voltage conversion transformers (single-phase or three-phase).

Primary Voltage	Secondary Voltage
1. 380 VAC to 480 V →	200 VAC
2. 380 VAC to 480 V →	100 VAC

Refer to the capacities shown in the following table when selecting a voltage conversion transformer.

Voltage	Servopack Model	Voltage capacity per Servopack* kVA
Single-phase 100 V	SGDH-A3BE	0.15
	SGDH-A5BE	0.25
	SGDH-01BE	0.40
	SGDH-02BE	0.60
Single-phase 200 V	SGDH-A3AE	0.20
	SGDH-A5AE	0.25
	SGDH-01AE	0.40
	SGDH-02AE	0.75
	SGDH-04AE	1.2
	SGDH-08AE-S	2.1
	SGDH-15AE-S	4.0
Three-phase 200 V	SGDH-05AE	1.4
	SGDH-08AE	1.9
	SGDH-10AE	2.3
	SGDH-15AE	3.2
	SGDH-20AE	4.3
	SGDH-30AE	5.9
	SGDH-50AE	7.5
	SGDH-60AE	12.5
	SGDH-75AE	15.5
	SGDH-60AE	12.5
	SGDH-75AE	15.5
	SGDH-1AAE	22.7
	SGDH-1EAE	30.9

* This is the net value at the rated load.

When using a 400-V class power supply, turn the power supply ON and OFF at the primary side of the voltage conversion transformer.

IMPORTANT

Transformer inductance will cause a surge voltage if the power is turned ON and OFF at the secondary, damaging the Servopack.

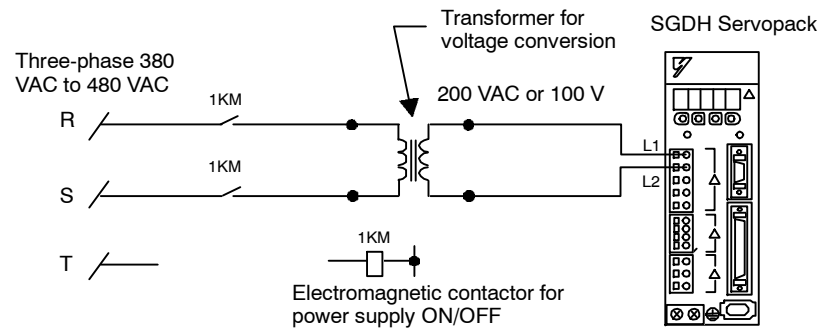

Figure 5.4 Single-phase Power Supply Connection Example

5.8.6 DC Reactor for Harmonic Suppression

SGDH Servopacks have DC reactor connection terminals for power supply harmonic suppression. Servopacks with capacities of 6 kW or more do not have these terminals.

■ Connecting a DC Reactor

The DC reactor is connected in series to the rectifier circuit's output side. Refer to 3.2 *Servopack Internal Block Diagrams*.

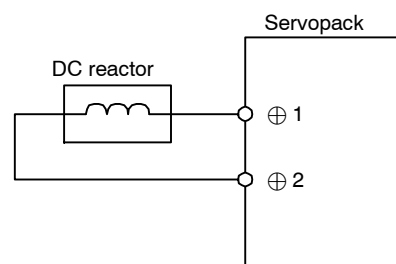

At the time of shipping, the DC reactor's (+)1 and (+)2 are short-circuited. Remove the lead wire between the two terminals and connect the DC reactor.

■ DC Reactor Specifications

The following table shows the specifications for the DC reactors provided by Yaskawa.

Applicable Servopacks		Reactor Specifications		Reactor Model
		Inductance (mH)	Rated current (A)	
Single-phase 100 V	SGDH-A3BE	-	-	-
	SGDH-A5BE	-	-	-
	SGDH-01BE	10.0	1.8	X5063
	SGDH-02BE	4.7	3.5	X5062
Single-phase 200 V	SGDH-A3AE	-	-	-
	SGDH-A5AE	-	-	-
	SGDH-01AE	40	0.85	X5071
	SGDH-02AE	20	1.65	X5070
	SGDH-04AE	10	3.3	X5069
	SGDH-08AE-S	4	5.3	X5079
	SGDH-15AE-S	2.5	10.5	X5078
Three-phase 200 V	SGDH-05AE	2.0	4.8	X5061
	SGDH-08AE			
	SGDH-10AE			
	SGDH-15AE	1.5	8.8	X5060
	SGDH-20AE			
	SGDH-30AE	1.0	14.0	X5059
	SGDH-50AE	0.47	26.8	X5068
Three-phase 400 V	SGDH-05DE	4.7	1.5	X5074
	SGDH-10DE	3.3	4.5	X5075
	SGDH-15DE			
	SGDH-20DE	2.2	8.6	X5076
	SGDH-30DE			
	SGDH-50DE	1.5	14.1	X5077

6

Servo Adjustment

This chapter describes the functions required for servo adjustment. Find the required information by selecting the section from the following table of contents.

6.1 Smooth Operation	6 - 2
6.1.1 Using the Soft Start Function	6 - 2
6.1.2 Smoothing	6 - 3
6.1.3 Adjusting Gain	6 - 4
6.1.4 Adjusting Offset	6 - 4
6.1.5 Setting the Torque Reference Filter Time Constant	6 - 5
6.1.6 Notch Filter	6 - 5
6.2 High-speed Positioning	6 - 6
6.2.1 Setting Servo Gain	6 - 6
6.2.2 Using Feed-forward Control	6 - 8
6.2.3 Using Proportional Control	6 - 8
6.2.4 Setting Speed Bias	6 - 9
6.2.5 Using Mode Switch	6 - 10
6.2.6 Speed Feedback Compensation	6 - 13
6.3 Autotuning	6 - 16
6.3.1 Online Autotuning	6 - 16
6.3.2 Mechanical Rigidity Settings for Online Autotuning	6 - 19
6.3.3 Saving Results of Online Autotuning	6 - 21
6.3.4 User Constants Related to Online Autotuning	6 - 23
6.4 Servo Gain Adjustments	6 - 25
6.4.1 Servo Gain User Constants	6 - 25
6.4.2 Basic Rules of Gain Adjustment	6 - 25
6.4.3 Making Manual Adjustments	6 - 27
6.4.4 Gain Setting Reference Values	6 - 31
6.5 Analog Monitor	6 - 33

6.1 Smooth Operation

This section provides technical information on the smooth operation of Servomotors.

6.1.1 Using the Soft Start Function

The soft start function adjusts progressive speed reference input inside the Servopack so that acceleration and deceleration can be as constant as possible. To use this function, set the following user constants.

Pn305	Soft Start Acceleration Time	Unit: ms	Setting Range: 0 to 10000	Factory Setting: 0	Speed Control
Pn306	Soft Start Deceleration Time	Unit: ms	Setting Range: 0 to 10000	Factory Setting: 0	Speed Control

In the Servopack, a speed reference is multiplied by the acceleration or deceleration value set in Pn305 or Pn306 to provide speed control.

The soft start function enables smooth speed control when inputting progressive speed references or when selecting internally-set speeds. Set both Pn305 and Pn306 to “0” for normal speed control.

Set these user constants as follows:

- Pn305: The time interval from the time the motor starts until the motor maximum speed is reached.
- Pn306: The time interval from the time the motor is operating at the motor maximum speed until it stops.

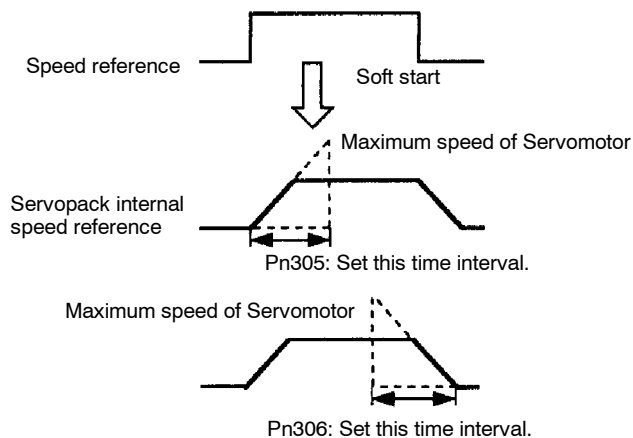

6.1.2 Smoothing

A filter can be applied in the Servopack to a constant-frequency reference pulse. Use the following user constant to set the type of filter to be applied.

Pn207.0	Position Reference Filter Selection	Factory Setting: 0	Position Control
----------------	--	-------------------------------------	-------------------------

Either an acceleration/deceleration or average movement filter can be selected.

Pn207.0 Setting	Meaning
0	Acceleration/deceleration filter
1	Average movement filter

The time constant and time for these filters are set in the following user constants.

Time Constant for Acceleration/Deceleration Filter

Pn204	Position Reference Acceleration/Deceleration Time Constant	Unit: 0.01ms	Setting Range: 0 to 6400	Factory Setting: 0	Position Control
--------------	---	-------------------------------	---	-------------------------------------	-------------------------

Averaging Time for Average Movement Filter

Pn208	Position Reference Movement Averaging Time	Unit: 0.01ms	Setting Range: 0 to 6400	Factory Setting: 0	Position Control
--------------	---	-------------------------------	---	-------------------------------------	-------------------------

After resetting the constant, turn OFF the power once and turn ON it again.

This function provides smooth motor operating in the following cases:

- When the host device which outputs references cannot perform acceleration/deceleration processing.
- When the reference pulse frequency is too low.
- When the reference electronic gear ratio is too high (i.e., 10 × or more).

This function does not affect the travel distance (i.e., the number of pulses).

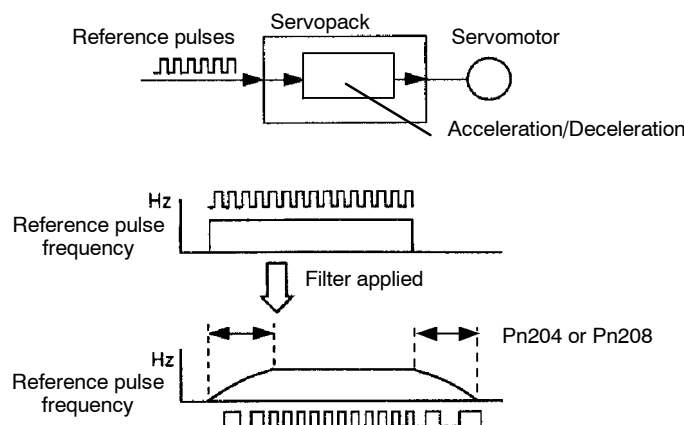

6.1.3 Adjusting Gain

If speed loop gain or position loop gain exceeds the allowable limit for the servo system including the machine to be controlled, the system will tend to vibrate or become too sensitive. Smooth operation is not possible under such conditions, so reduce each loop gain value to an appropriate value.

Refer to 6.2.1 *Setting Servo Gain* for details regarding servo gain adjustment.

6.1.4 Adjusting Offset

The servo system does not operate smoothly if reference voltage from the host controller or external equipment has a reference offset value in close proximity to 0 V. In that case, adjust the reference offset value to 0 V.

■ Reference Voltage Offset from Host Controller or External Circuitry

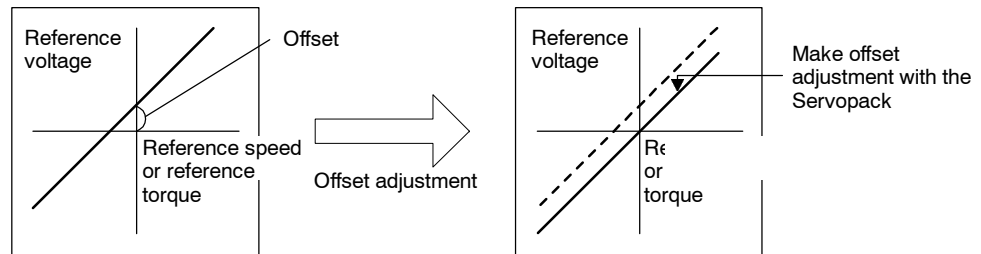

■ Reference Offset Adjustment

The following two methods are available to set the reference offset value to 0 V.

Reference offset automatic adjustment	The reference offset value is automatically set to 0 V.
Reference offset manual adjustment	The reference offset value can be adjusted manually.

IMPORTANT

If a position loop is formed in the host controller, be sure to make manual offset adjustment and do not make automatic reference offset adjustment.

Refer to the following sections in *Chapter 7 Using the Digital Operator* for reference offset adjustment in detail.

Reference Offset Automatic Adjustment	7.2.3 <i>Automatic Adjustment of the Speed and Torque Reference Offset</i>
Reference Offset Manual Adjustment	7.2.4 <i>Manual Adjustment of the Speed and Torque Reference Offset</i>

6.1.5 Setting the Torque Reference Filter Time Constant

If there is machine vibration which may be caused by the servodrive, try adjusting the filter time constant in Pn401. This may stop the vibration.

Pn401	Torque Reference Filter Time Constant	Unit: 0.01ms	Setting Range: 0 to 65535	Factory Setting: 100	Speed/Torque Control, Position Control
--------------	--	------------------------	-------------------------------------	--------------------------------	---

The above constant is the filter time constant of the torque reference to be set in the Servopack. The smaller the value, the faster the speed control response will be. There is, however, a certain limit depending on machine conditions.

6.1.6 Notch Filter

Vibration in the machine can sometimes be eliminated by using a notch filter for the frequency at which the vibration is occurring.

Pn408.0	Notch Filter Selection	Factory Setting: 0	Speed/Torque Control, Position Control
----------------	-------------------------------	------------------------------	---

This user constant can be set to enable the notch filter.

Pn408.0 Setting	Contents
0	None
1	Notch filter used for torque reference.

The frequency at which the machine is vibrating is set in the following user constant.

Pn409	Notch Filter Frequency	Unit: Hz	Setting Range: 50 to 2000	Factory Setting: 2000	Speed/Torque Control, Position Control
--------------	-------------------------------	--------------------	-------------------------------------	---------------------------------	---

6.2 High-speed Positioning

This section provides technical information on high-speed positioning.

6.2.1 Setting Servo Gain

Use the servo gain setting function in the following cases.

- To check each servo gain value that is automatically set after auto-tuning.
- To directly set each of the above servo gain values in another Servopack.
- To further refine responsiveness after autotuning (either to increase responsiveness or to reduce it).

■ Setting Speed Loop Gain

Set the following speed-loop-related user constants as required.

Pn100	Speed Loop Gain (Kv)	Unit: Hz	Setting Range: 1 to 2000	Factory Setting: 40	Speed/Torque Control, Position Control
Pn101	Speed Loop Integral Time Constant (Ti)	Unit: 0.01ms	Setting Range: 15 to 51200	Factory Setting: 2000	Speed Control, Position Control

The above constants are the Servopack's speed loop gain and integral time constant respectively.

The higher the speed loop gain, or the smaller the speed loop integral time constant value, the faster the speed control response will be. There is, however, a certain limit depending on machine characteristics.

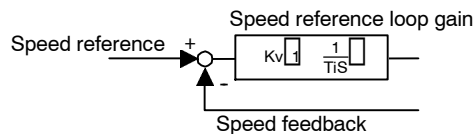

Speed loop gain Kv is adjusted in 1-Hz increments provided that the following user constant is set correctly.

Pn103	Inertia Ratio	Unit: %	Setting Range: 0 to 10000	Factory Setting: 0	Speed/Torque Control, Position Control
--------------	----------------------	--------------------------	--	-------------------------------------	---

$$\text{Inertia ratio} = \frac{\text{Motor axis conversion load inertia (J}_L\text{)}}{\text{Servomotor rotor inertia (J}_M\text{)}} \times 100(\%)$$

The load inertia of the Servopack converted on the basis of the motor shaft is factory-set to the rotor inertia of the Servomotor. Therefore, obtain the inertia ratio from the above formula and set user constant Pn103 properly.

The above user constants are automatically set by the autotuning operation.

■ Setting Position Loop Gain

Set the following position loop-related user constant as required.

Pn102	Position Loop Gain (Kp)	Unit: 1/s	Setting Range: 1 to 2000	Factory Setting: 40	Speed Control, Position Control
-------	-------------------------	--------------	--------------------------------	---------------------------	------------------------------------

The above constant is the position loop gain for the Servopack.

The higher the position loop gain, the smaller the position control error will be. There is, however, a certain limit depending on machine characteristics.

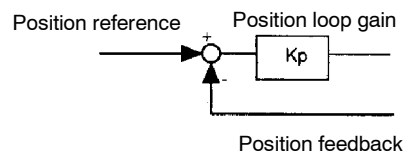

This gain setting is also valid for zero clamp operation.

The above user constant is automatically set by the autotuning operation.

Pn505	Overflow level	Unit: 256 reference units	Setting Range: 1 to 32767	Factory Setting: 1024	Position Control
-------	----------------	------------------------------------	---------------------------------	-----------------------------	------------------

Set in this user constant the error pulse level at which a position error pulse overflow alarm (A.d0) is detected.

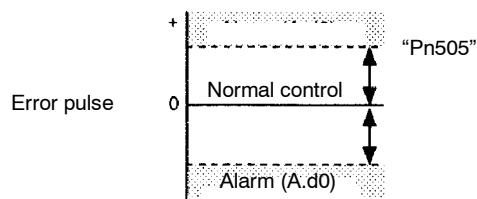

If the machine permits only a small position loop gain value to be set in Pn102, an overflow alarm may arise during high-speed operation. In this case, increase the value set in this user constant to suppress alarm detection.

6.2.2 Using Feed-forward Control

The time required for positioning can be shortened with feed-forward control by setting the following user constant.

Pn109	Feed-forward	Unit: %	Setting Range: 0 to 100	Factory Setting: 0	Speed Control Position Control
--------------	---------------------	-------------------	--	-------------------------------------	---

This user constant is set to apply feed-forward frequency compensation to position control inside the Servopack. Use this user constant to shorten positioning time. Too high a value may cause the machine to vibrate. For ordinary machines, set 80% or less in this constant.

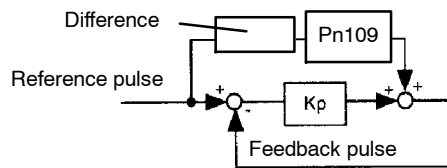

6.2.3 Using Proportional Control

If user constant Pn000.1 is set to 0 or 1 as shown below, input signal /P-CON serves as a PI/P control changeover switch.

- PI control: Proportional/integral control.
- P control: Proportional control.

Pn000.1	Control Method Selection	Factory Setting: 0	Speed Control Position Control
----------------	---------------------------------	-------------------------------------	---

Pn000.1 setting	Control Mode					
0	Speed Control	Usual speed control or position control is selected. Input signal /P-CON (CN1-41) is used to select PI control or P control.				
1	Position Control	<table border="1"> <tr> <td>CN1-41 is open.</td> <td>PI control</td> </tr> <tr> <td>CN1-41 is 0 V</td> <td>P control</td> </tr> </table>		CN1-41 is open.	PI control	CN1-41 is 0 V
CN1-41 is open.	PI control					
CN1-41 is 0 V	P control					



◆ Feed-forward control

Feed-forward control is a type of control in which necessary control connections are made in advance before the control system is affected by external disturbance. Feed-forward control increases the effective servo gain, thus making it possible to improve the response performance of the system.

■ Methods for Using Proportional Control

Proportional control can be used in the following two ways.

- When operation is performed by sending speed references from the host controller to the Servopack, the host controller can selectively use P control mode for particular conditions only. This method can suppress overshooting and shorten setting time. Refer to 6.2.5 *Using Mode Switch* for particular conditions.
- If PI control mode is used when the speed reference has a reference offset, the motor may rotate at a very slow speed and fail to stop even if 0 is specified as a speed reference. In this case, use P control mode to stop the motor.

6.2.4 Setting Speed Bias

The settling time for positioning can be reduced by assigning bias to the speed reference block in the Servopack. To assign bias, use the following constants.

Pn107	Bias	Unit: r/min	Setting Range: 0 to 450	Factory Setting: 0	Position Control
Pn108	Bias Addition Width	Unit: Reference units	Setting Range: 0 to 250	Factory Setting: 7	Position Control

Set the constants to shorten the time required for positioning according to the application.

The bias increment width (Pn108) is expressed by a error pulse width that determine the timing of giving bias input (Pn107). The bias input is ON if the error pulse width exceeds the value set in Pn108.

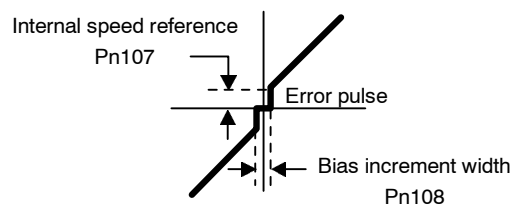

6.2.5 Using Mode Switch

Use the mode switch function for the following purposes.

- To suppress overshooting during acceleration or deceleration (for speed control).
- To suppress undershooting during positioning and to shorten the setting time (for position control).

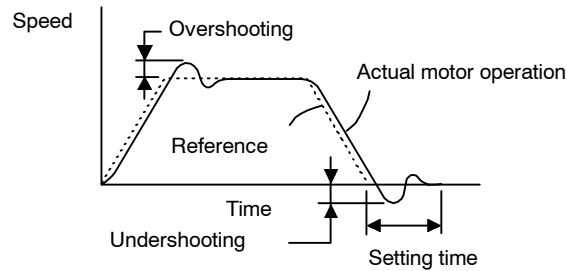

The mode switch function makes it possible to automatically switch over the Servopack's internal speed control mode from PI to P control mode and vice versa when specified conditions are satisfied.

IMPORTANT

1. The mode switch is used to fully utilize performance of a servodrive to achieve very high-speed positioning. The speed response waveform must be observed to adjust the mode switch.
2. For normal use, the speed loop gain and position loop gain set by autotuning provide sufficient speed/position control. Even if overshooting or undershooting occur, they can be suppressed by setting the acceleration/deceleration time constant for the host device, the soft start time constants (Pn305, Pn306), or position reference acceleration/deceleration constant (Pn204) for the Servopack.

■ Selecting Mode Switch Setting

The Servopack incorporates four mode switch settings (0 to 3). Select a mode switch with the following user constant (Pn10B.0).



◆ From PI control to P control

PI control means proportional/integral control and P control means proportional control. In short, switching "from PI control to P control" reduces effective servo gain, making the servo system more stable.

Setting	Selection	User Constant to Set Detective Point	Set Unit
0	Uses torque reference as the detection point. (Standard setting)	Pn10C	Percentage of rated torque: %
1	Uses speed reference input as the detection point.	Pn10D	Motor speed: r/min
2	Uses acceleration as the detection point.	Pn10E	Motor acceleration: 10 (r/min)/s
3	Uses error pulse input as the detection point.	Pn10F	Reference unit
4	Mode switch function is not used.	-	-

Torque Reference Input Used as Detection Point (Standard Setting)

With this setting, if the value of torque reference input exceeds the torque set in user constant Pn10C, the speed loop switches to P control.

The Servopack is factory-set to this standard mode (Pn10C = 200).

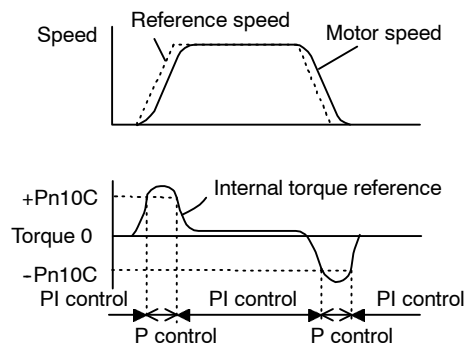

EXAMPLE

Operating Example

If the system is always in PI control without using the mode switch function, the speed of the motor may overshoot or undershoot due to torque saturation at the time of the acceleration or deceleration of the motor. The mode switch function suppresses torque saturation and eliminates the overshooting or undershooting of the speed of the motor.

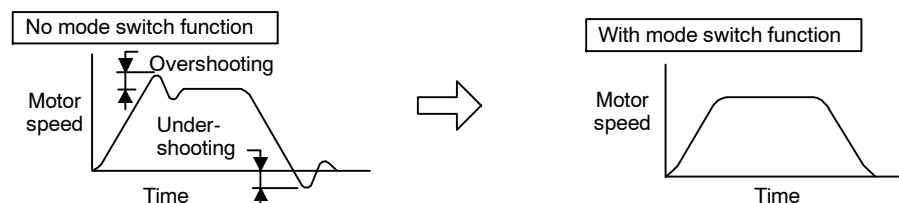

Speed Reference Used as Detection Point

With this setting, if a speed reference exceeds the value set in user constant Pn10D, the speed loop switches to P control.

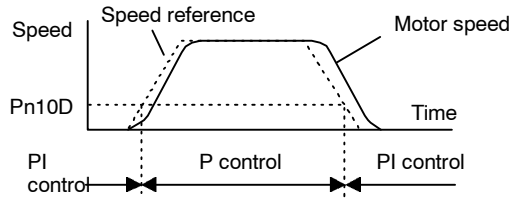

EXAMPLE

Operating Example

In this example, the mode switch is used to reduce setting time. Generally, speed loop gain must be increased to reduce setting time. Using the mode switch suppresses the occurrence of overshooting and undershooting when speed loop gain is increased.

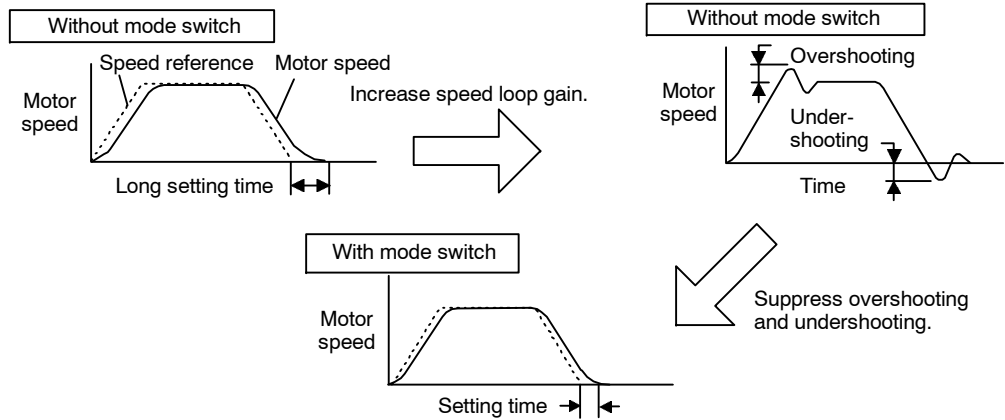

Acceleration Used as Detection Point

If motor acceleration exceeds the value set in user constant Pn10E, the speed loop switches to P control.

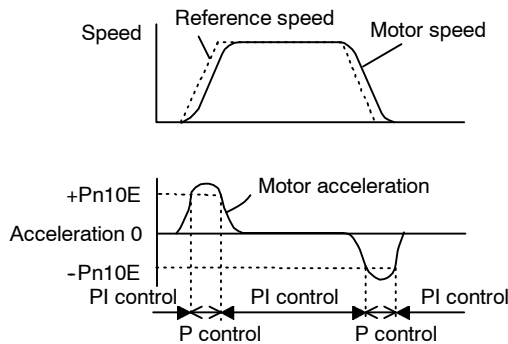

EXAMPLE

Operating Example

If the system is always in PI control without using the mode switch function, the speed of the motor may overshoot or undershoot due to torque saturation at the time of the acceleration or deceleration of the motor. The mode switch function suppresses torque saturation and eliminates the overshooting or undershooting of the motor speed.

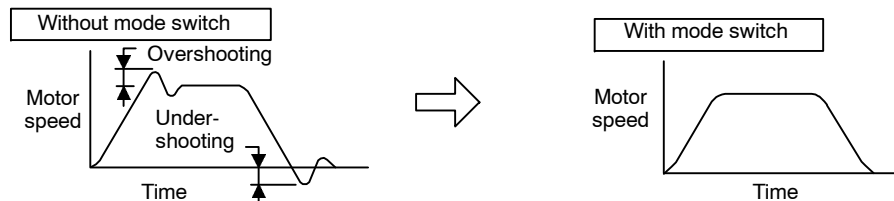

Error Pulse Used as Detection Point

This setting is enabled for position control operation only.

If an error pulse exceeds the value set in user constant Pn10F, the speed loop switches to P control.

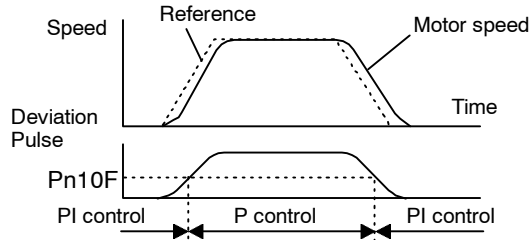

EXAMPLE

Operating Example

In this example, the mode switch is used to reduce setting time. Generally, speed loop gain must be increased to reduce setting time. Using the mode switch suppresses the occurrence of overshoot and undershoot when speed loop gain is increased.

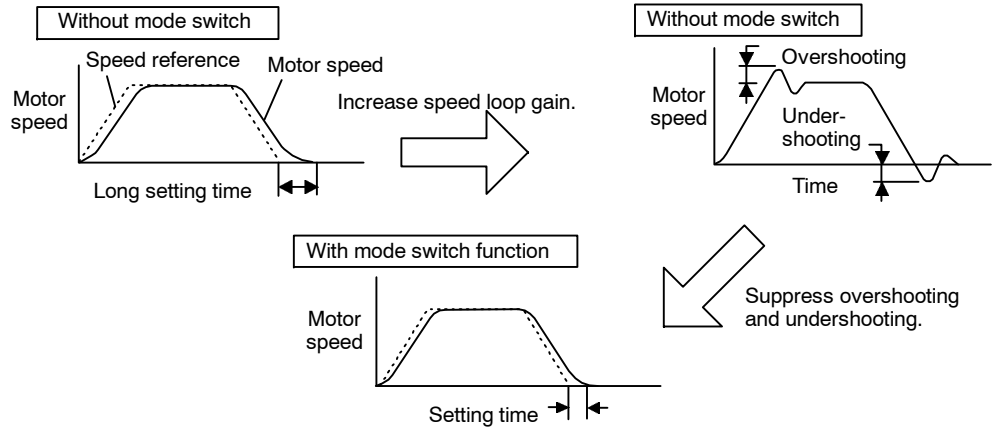

6.2.6 Speed Feedback Compensation

Use this function for shortening the setting time of the system in positioning operation.

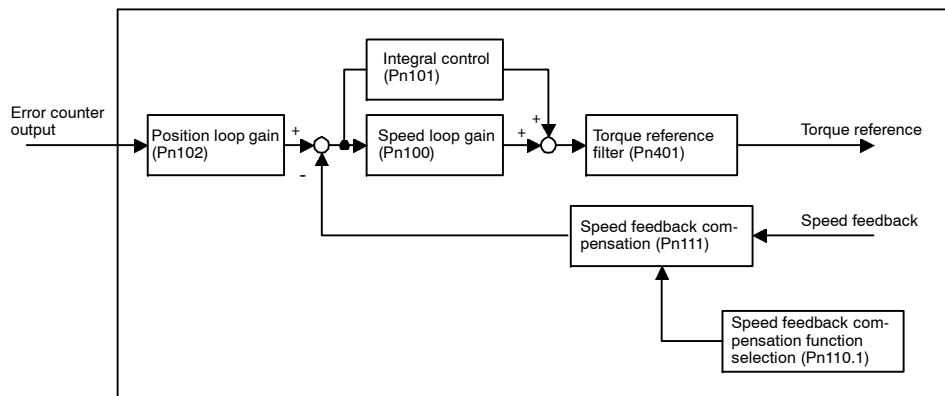



This function is available provided that the inertia ratio set in Pn103 is correct. Therefore, perform online autotuning to obtain and save the results as the user constants. Refer to 6.3 *Autotuning* for details. Alternatively, directly set the inertia ratio.

■ Adjustment Procedure

When adding the value of speed feedback compensation, be sure to follow the procedure described below and make servo gain adjustments while watching the analog monitor to observe the position error and torque reference. Refer to *LEERER MERKER Analog Monitor* for details.

1. Set user constant Pn110 to “0002” so that the online autotuning function will be disabled. Refer to 6.3.4 *User Constants Related to Online Autotuning* and *Appendix LEERER MERKER List of User Constants* for details regarding Pn110.
2. First, make normal servo gain adjustments with no feedback compensation. In this case, gradually increase the speed loop gain in Pn100 while reducing the speed loop integral time constant Pn101, and finally set the speed loop gain in Pn100 to the same value as that of the position loop gain in Pn102.

The relationship between the speed loop gain and integral time constant is as follows:

Take the value obtained from the following formula as a reference value for setting the speed loop integral time constant in Pn101.

$$\text{Speed loop integral time constant} = \frac{4}{2\pi \times \text{Speed loop gain}} \text{ [sec]}$$

Unit of speed loop gain :[Hz]

Check the unit when setting the speed loop integral time constant in Pn101. Pn101 can be set in 0.01 ms increments.

The unit of speed loop gain (i.e., Hz) and that of position loop gain (i.e., 1/s) are different to each other. Set these gains to the same value, however.

3. Repeat step 2. to increase the speed loop gain while watching the position error of the analog monitor to observe the setting time and the torque reference of the analog monitor to observe any occurrence of vibration. If there is any oscillating noise or noticeable vibration, gradually increase the time constant of the torque reference filter in Pn401.
4. Gradually increase only the position loop gain. When it has been increased about as far as possible, then decrease the speed feedback compensation in Pn111 from 100% to 90%. Then repeat steps 2. and 3.
5. Decrease the speed feedback compensation to a value lower than 90%. Then repeat steps 2. through 4. to shorten the setting time. If the speed feedback compensation is too low, however, the response waveform will vibrate.
6. Find the condition in which the shortest setting time is obtainable within the range where the position error or torque reference waveform observed through the analog monitor is not vibrating or unstable.
7. The servo gain adjustment is completed when no further shortening of the positioning time is possible.

IMPORTANT

Speed feedback compensation usually makes it possible to increase the speed loop gain and position loop gain. The machinery may vibrate excessively if the compensation value greatly changes or Pn110.1 is set to “1” (i.e., no speed feedback compensation enabled) after increasing the speed loop gain or position loop gain.

6.3 Autotuning

If positioning is taking a long time, the speed loop gain or position loop gain of the servo system may not be set properly. If the gain settings are wrong, set them properly in accordance with the configuration and rigidity of the machinery.

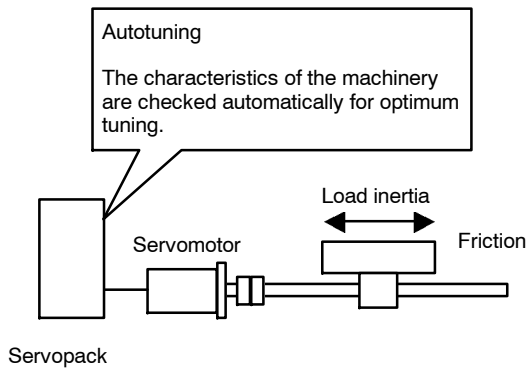

The Servopack incorporates an online autotuning function, which checks the characteristics of the machinery automatically and makes the necessary servo gain adjustments. The function is easy to use and makes it possible for even beginners to perform servo gain tuning and set all servo gains as user constants.

The following user constants can be set automatically by using the online autotuning function.

User Constant	Content
Pn100	Speed loop gain
Pn101	Speed loop integral time constant
Pn102	Position loop gain
Pn401	Torque reference filter time constant

6.3.1 Online Autotuning

Online autotuning is a control function which enables the Servoamp to check changes in the load inertia during operation in order to maintain the target value for speed loop gain or position loop gain.

Online autotuning may not work well in the following cases.

- When the cycle for load inertia change is 200 ms or shorter (when the load changes rapidly).
- When the application has slow acceleration or deceleration using the soft start function, and the speed error of the Servomotor being driven is small.
- When adjusting the Servomotor manually and operating at low gain (a machine rigidity of 1 or less).

Disable the online autotuning function if tuning is not possible. (See 6.4.3.)

IMPORTANT

Do not use online autotuning in the following cases.

- When driving using Torque Control Mode.
 - When using IP control for the speed loop.
 - When using the torque feed-forward function.
 - When switching gain using /G-SEL.
-

■ Setting User Constants for Online Autotuning

The following flowchart shows the procedure for setting the user constants for online autotuning.

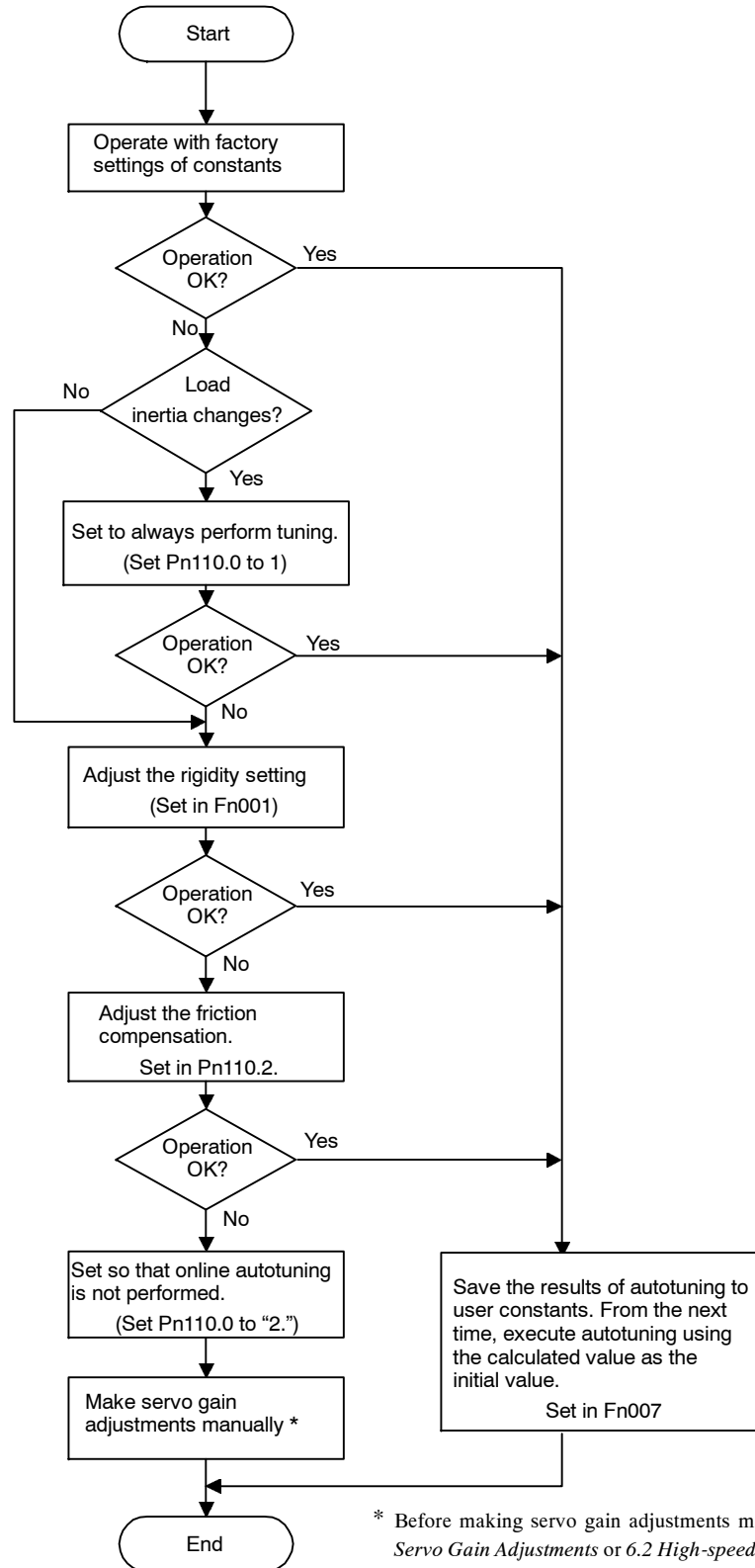

* Before making servo gain adjustments manually, refer to 6.4 Servo Gain Adjustments or 6.2 High-speed Positioning.

6

6.3.2 Machine Rigidity Settings for Online Autotuning

For the machine rigidity settings at the time of online autotuning, select the target values for speed loop gain and position loop gain of the servo system. Any of the following ten levels of rigidity can be selected.

Rigidity Setting Fn001	Position Loop Gain [S ⁻¹] Pn102	Speed Loop Gain [Hz] Pn100	Speed Loop Integral Time Constant [0.01ms] Pn101	Torque Reference Filter Time Constant [0.01ms] Pn401
1	15	15	6000	250
2	20	20	4500	200
3	30	30	3000	130
4	40	40	2000	100
5	60	60	1500	70
6	85	85	1000	50
7	120	120	800	30
8	160	160	600	20
9	200	200	500	15
10	250	250	400	10

Note The Rigidity value is factory-set to 4.

As the rigidity value is increased, the servo system loop gain increases and the time required for positioning is shortened. If the rigidity is excessively high, however, it may cause the machinery to vibrate. In that case, decrease the set value.

The rigidity value setting automatically changes the user constants in the above table.



If user constants Pn102, Pn100, Pn101, and Pn401 are set manually with the online autotuning function enabled, tuning is performed with the manually set values as target values.

■ Changing the Rigidity Setting

Use user constant Fn001 in the auxiliary function mode to change the rigidity setting.

The procedure for changing the setting is as follows:

Using the Hand-held Digital Operator

1. Press the DSPL/SET Key and select Fn001 in the auxiliary function mode.

Fn001

2. Press the DATA/ENTER Key. The following data will be displayed.

d.0004

3. Press the Up or Down Cursor Key to select the rigidity setting.

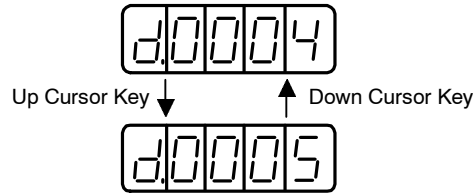

4. Press the DSPL/SET Key. The following display will flash for 1 second and then the rigidity setting will be changed.



5. Press the DATA/ENTER Key to return to the auxiliary function mode.



This completes the procedure for changing the rigidity setting.

Using the Built-in Panel Operator

1. Press the MODE/SET Key to select Fn007 in the auxiliary function mode.



2. Press the DATA/SHIFT Key for a minimum of 1 second. The following data will be displayed.



3. Press Up or Down Cursor Key to select the rigidity setting.

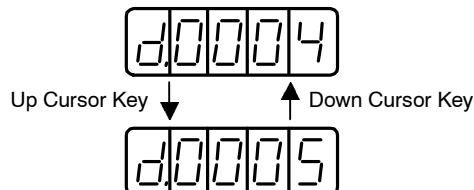

4. Press the MODE/SET Key. The following display will flash for 1 second and then the rigidity setting will be changed.

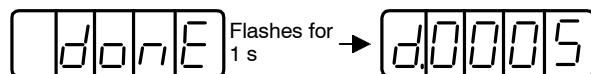

5. Press the DATA/SHIFT Key for a minimum of 1 second to return to the auxiliary function mode.

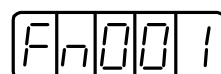

This completes the procedure for changing the rigidity setting.

6

6.3.3 Saving Results of Online Autotuning

Online autotuning always processes the latest load inertia to renew data so that the speed loop gain will reach the target value that has been set. When the Servopack is turned off, all the processed data is lost. Therefore, when the Servopack is turned on again, online autotuning is performed by processing the factory-set values in the Servopack.

To save the results of online autotuning and use them as the initial values set in the Servopack when the Servopack is turned on again, it is necessary to use constant Fn007 in the auxiliary function mode. In this case, the inertia value set in user constant Pn103 can be changed.

On the basis of the rotor inertia of the Servomotor, the inertia ratio is expressed in percentage terms by the load inertia. The value set in Pn103 is used to calculate the load inertia at the time of online autotuning.

Pn103	Inertia Ratio	Unit:	Setting Range:	Factory Setting:	Speed/Torque Control, Position Control
		%	0 to 10000	0	

$$\text{Inertia ratio} = \frac{\text{Motor axis conversion load inertia (J}_L\text{)}}{\text{Servomotor moment of inertia (J}_M\text{)}} \times 100(\%)$$

The inertia ratio is factory-set to 0%.

IMPORTANT

Before making servo gain adjustments manually, be sure to set the inertia ratio in Pn103. If the inertia ratio is incorrect, the speed loop gain (in 1-Hz increments) set in Pn100 will be wrong.

For details on setting Pn103, refer to 7.1.6 *Operation in User Constant Setting Mode*.

■ Procedure for Saving Results of Online Autotuning

The procedure for saving the results of online autotuning is as follows:

Using the Hand-held Digital Operator

1. Press the DSPL/SET Key to select Fn007 in the auxiliary function mode.

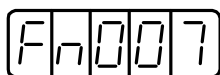

The display shows the text 'Fn007' in a digital font, indicating that the auxiliary function mode Fn007 has been selected.

2. Press the DATA/ENTER Key. If the inertia ratio is 200%, for example, the following data will be displayed.

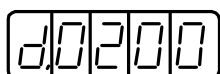

The display shows the text 'd.0200' in a digital font, representing the inertia ratio of 200%.

3. Press the DSPL/SET Key. The following display will flash for 1 second and then the inertia ratio will be saved.

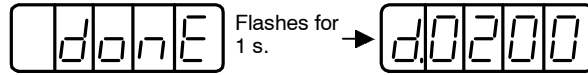

4. Press the DATA/ENTER Key to return to the auxiliary function mode.

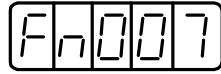

This completes the procedure for saving the results of online autotuning. When the Servopack is turned on again, the inertia ratio set in Pn103 will be used as the default value.

Using the Built-in Panel Operator

1. Press the MODE/SET Key and select Fn007 in the auxiliary function mode.



2. Press the DATA/SHIFT Key for a minimum of 1 second. If the inertia ratio is 200%, for example, the following data will be displayed.

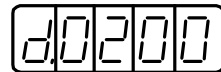

3. Press the MODE/SET Key. The following display will flash for 1 second and then the inertia ratio will be saved.

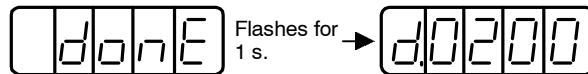

4. Press the DATA/SHIFT Key for a minimum of 1 second to return to the auxiliary function mode.

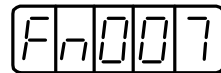

This completes the procedure for saving the results of online autotuning. When the Servopack is turned on again, the inertia ratio set in Pn103 will be used as the default value.

6.3.4 User Constants Related to Online Autotuning

This section provides information on a variety of user constants related to online autotuning.

■ Online Autotuning Method

The following user constant is used for setting the autotuning conditions.

Pn110.0	Online Autotuning Method	Factory Setting: 0	Speed Control, Position Control
----------------	---------------------------------	------------------------------	--

Pn110.0 Setting	Description
0	Autotuning is performed only when the system runs for the first time after the power is turned ON. After the load inertia is calculated, the calculated data is not refreshed.
1	Autotuning is continuously performed (inertia value calculation).
2	The online autotuning function is not used.

This user constant is factory-set to “0”. If the load inertia change is minimal or if the application makes few changes, there is no need to continue calculating the inertia while the system is in operation. Instead, continue to use the value that was calculated when the system was first started up.

Set this user constant to “1” if the load inertia always fluctuates due to the load conditions. Then the response characteristics can be kept stable by continuously refreshing the inertia calculation data is refreshed continuously and reflecting them in the servo gain.

If the load inertia fluctuation results within 200 ms, the inertia calculation data may not be refreshed properly. If that happens, set Pn110.0 to “0” or “2.”

Set Pn110.0 to “2” if autotuning is not available or if the online autotuning function is not used because the load inertia is already known and the Servopack is manually adjusted by setting the inertia ratio data in Pn103.

■ Speed Feedback Compensation Selection

Use the following user constant to enable or disable speed feedback compensation. Refer to 6.2.6 *Speed Feedback Compensation*.

This user constant can be left as it is if online autotuning is performed. If this user constant is set manually, however, the setting is reflected to the operational setting made during online autotuning.

Pn110.1	Speed Feedback Compensation Selection	Factory Setting: 1	Speed Control, Position Control
----------------	--	------------------------------	--

Pn110.1 Setting	Description
0	Enabled
1	Disabled

■ Friction Compensation Selection

Use the following user constant to enable or disable friction compensation to determine whether or not the friction of the servo system is to be taken into consideration for the calculation of load inertia.

If this compensation function is enabled, select small or large friction compensation according to the extent of friction in order to ensure highly precise load inertia calculation.

Pn110.2	Friction Compensation Selection	Factory Setting: 1	Speed Control, Position Control
----------------	--	-------------------------------------	--

Pn110.2 Setting	Description
0	Friction compensation: Disabled
1	Friction compensation: Small
2	Friction compensation: Large



1. Do not set friction compensation for loads with low friction (10% rated torque/speed or less).
2. Autotuning will be perform as if the load inertia was 30 times the motor inertia.

6.4 Servo Gain Adjustments

This section describes information on the basic rules of gain adjustments in the Servopack, adjustment methods in a variety of cases, and reference set values.

6.4.1 Servo Gain User Constants

The following user constants must be set properly for servo gain adjustments.

- Pn100: Speed loop gain
- Pn101: Speed loop integral time constant
- Pn102: Position loop gain
- Pn401: Torque reference filter time constant

If the Servopack is used in the speed control mode with the analog voltage reference, the position loop is controlled by the host device. Therefore, position loop gain is adjusted through the host device.

If the host is not available for adjustments of position loop gain, set the speed reference input gain in user constant Pn300. If the set value is improper, the Servomotor may not run at top speed.

6.4.2 Basic Rules of Gain Adjustment

The servo system consists of three feedback loops (i.e., position loop, speed loop, and current loop). The innermost loop must have the highest response speed and the middle loop must have higher response speed than the outermost. If this principle is not followed, it will result in vibration or poor responsiveness.

The Servopack is designed to ensure that the current loop has good response performance. The user need only adjust position loop and speed loop gain.

The servo system block diagram consists of the position, speed, and current loops, as shown below.

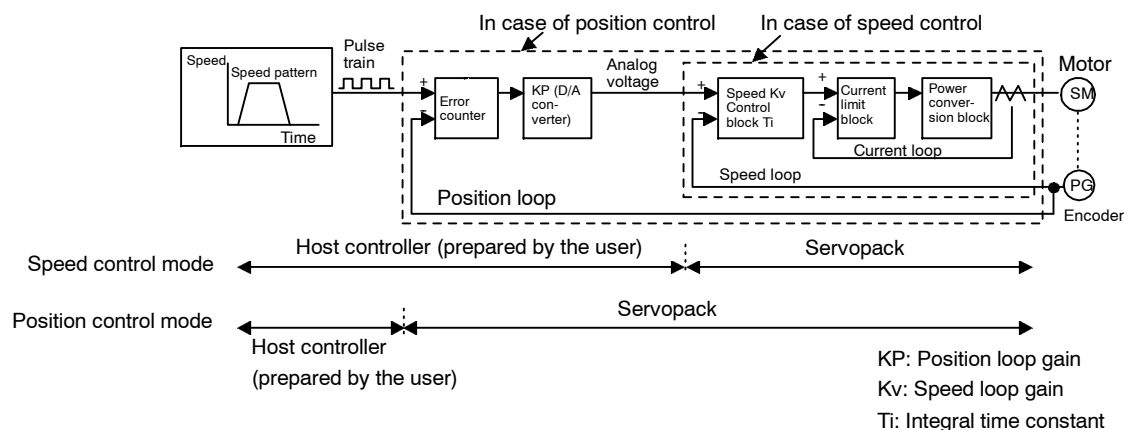

Figure 6.1 Servo System Block Diagram

- Generally speaking, the responsiveness of the position loop cannot be higher than that of the speed loop. Therefore, to increase the position loop gain, you must first increase the speed loop gain. If only the position loop gain is increased, oscillation will result in the speed reference and positioning time will increase, not decrease.

Position loop gain can be increased only to the point where oscillation begins in the mechanical system.

- If the position loop response is faster than the speed loop response, speed reference output from the position loop cannot follow the position loop response due to the slow speed loop response. Therefore, smooth linear acceleration or deceleration will not be possible and the position loop will keep accumulating errors, thus increasing the amount of speed reference output.

As a result, the motor speed will be excessive and the position loop will try decreasing the amount of speed reference output. The speed loop responsiveness will be poor, however, and the motor will not be able to catch up with the speed reference. As a result, the speed reference will oscillate as shown in the following graph. If this happens, reduce the position loop gain or increase the speed loop gain to prevent the speed reference from oscillating.

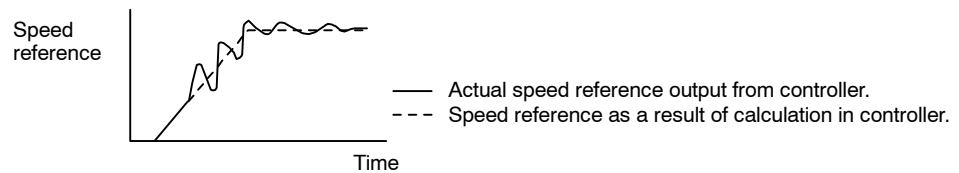

Figure 6.2 Speed Reference with Position Loop Gain and Speed Loop Responsiveness Not Well-balanced

6

- The position loop gain must not exceed the natural frequency of the mechanical system. For example, if the mechanical system is an articulated robot, the rigidity of the machinery mechanism is very low because the mechanism incorporates a wave reduction gear and the natural frequency of the mechanical system is 10 to 20 Hz. In this case, the position loop gain can be set to 10 to 20 (1/s).

If the mechanical system is a chip mounting machine, IC bonding machine, or high-precision machining tool, the natural frequency of the system is 70 Hz or more. Therefore, the position loop gain can be set to 70 (1/s) or higher.

- When high responsiveness is required, it is not only important to ensure the responsiveness of the servo system that is employed (the controller, Servopack, motor, and encoder), but it is also necessary to ensure that the mechanical system have high rigidity.

6.4.3 Making Manual Adjustments

The autotuning function uses a gain adjustment algorithm with a comparatively large safety margin by considering a variety of mechanical systems to which the Servopack is applied. Therefore, the Servopack may not satisfy the response characteristics of some applications. The autotuning function is not available to machines with low rigidity or high fluctuation.

In such cases, observe the mechanical systems and make manual adjustments of user constants.

■ Speed Control

Required User Constants

The following user constants are used.

- Speed Loop Gain (Pn100)

This user constant is used for determining the response speed of the speed loop. The response speed increases if the constant is set to a large value provided that the mechanical system does not vibrate. The value of speed loop gain is the same as the set value of Pn100 if the inertia ratio set in Pn103 is correct.

Speed loop gain $K_v = \text{Set value of Pn100 (Hz)}$

Set Pn103 to the following value.

$$\text{Pn103 setvalue} = \frac{\text{Motor axis conversion load inertia (J}_L\text{)}}{\text{Servomotor rotor inertia (J}_M\text{)}} \times 100(\%)$$



In the case of manual adjustments of user constants, the user must set the value of user constant Pn103. The inertia ratio can be obtained if the servo gain constant is written with user constant Fn007 after autotuning has been performed. For details regarding Fn007, refer to 6.3 *Autotuning*.

- Speed Loop Integral Time Constant (Pn101)

The speed loop has an integral element so that the speed loop can respond to minute inputs. This integral element delays the operation of the servo system, so a longer positioning setting time is required with slower response speed as the value of the time constant increases. If the load inertia is large or the mechanical system is likely to vibrate, make sure that the speed loop integral time constant is large enough; otherwise the mechanical system will vibrate. The following formula is the standard.

$$T_i \approx 2.3 \frac{1}{K_v}$$

T_i : Integral time constant [s]

K_v : Speed loop gain (calculated from the above) [Hz]

- Torque Reference Filter Time Constant (Pn401)

If the mechanical system uses ball screws, torsion resonance may result, in which case the oscillation noise will be a high-pitched tone. The oscillation may be stopped by increasing the time constant of the torque reference filter. Like the integral time constant, this filter causes a delay in the operation of the servo system. Therefore, this constant must not be set to an excessively large value.

- Speed Reference Input Gain (Pn300)

Changing the speed reference input gain set in Pn300 is equivalent to changing the position loop gain. In other words, an increase in the speed reference input gain set in Pn300 is equivalent to a decrease in the position loop gain and vice versa. Use this user constant in the following cases.

- When the host controller does not have a function for adjusting the position loop gain. (The host incorporates a D/A converter to change the number of bits but cannot make fine adjustments of position loop gain.)
- When it is necessary to clamp the full range of the speed reference output of the host device to a specified rotation speed.

In normal operation, the factory-set value can be used as it is.



If the Servopack is used for speed control, the position loop gain set in Pn102 is enabled in zero-clamp mode only. In normal control operation, change the position loop gain through the host or change the speed reference input gain in Pn300 in the Servopack. The position loop gain remains the same if the setting in Pn102 is changed.

Adjustment Method

1. Set the position loop gain to a comparatively low value in the host device. Then increase the speed loop gain set in Pn100 to within a range where there is no noise or oscillation resulting. If the position loop gain cannot be changed through the host device, increase the speed reference input gain set in Pn300 to a larger value.
2. Decrease the speed loop gain a little from the value set in step 1. Then increase the position loop gain through the host controller to within a range where there is no noise or oscillation resulting. As in step 1., decrease the set value of Pn300 if the position loop gain cannot be changed through the host device.
3. Set the speed loop integral time constant in Pn101 while observing the positioning setting time and the vibration of the mechanical system. If the constant is too large, positioning setting time will be long.
4. Set the torque reference filter to a small value in Pn401 if the mechanical system has shaft torsion resonance. If the mechanical system generates oscillation noise in a high-pitched tone, shaft torsion resonance may be occurring. In that case, set Pn401 to a larger value.
5. Finally, progressively make fine adjustments to user constants such as the position loop gain, speed loop gain, and integral time constant to find the optimal points.

■ Position Control

User Constants

The following user constants are used.

- Speed Loop Gain (Pn100)

This user constant is used for determining the response speed of the speed loop. The response speed increases if the constant is set to a large value provided that the mechanical system does not vibrate. The value of speed loop gain is the same as the set value of Pn100 if the inertia ratio set in Pn103 is correct.

Speed loop gain $K_v = \text{Set value of Pn100 (Hz)}$

Set Pn103 to the following value.

$$\text{Pn103 set value} = \frac{\text{Motor axis conversion load inertia (J}_L\text{)}}{\text{Servomotor rotor inertia (J}_M\text{)}} \times 100(\%)$$



In the case of manual adjustments of user constants, the user must set the value of user constant Pn103. The inertia ratio can be obtained if the servo gain constant is written with user constant Fn007 after autotuning has been performed. For details regarding Fn007, refer to 6.3 *Autotuning*.

- Speed Loop Integral Time Constant (Pn101)

The speed loop has an integral element so that the speed loop can respond to minute inputs. This integral element delays the operation of the servo system, so a longer positioning setting time is required with slower response speed as the value of the time constant increases.

If the load inertia is large or the mechanical system is likely to vibrate, make sure that the speed loop integral time constant is large enough; otherwise the mechanical system will vibrate. The following is a standard.

$$T_i \square 2.3 \frac{1}{K_v}$$

Ti: Integral time constant [s]

Kv: Speed loop gain (calculated from the above) [Hz]

- Torque Reference Filter Time Constant (Pn401)

If the mechanical system uses ball screws, torsion resonance may result, in which case the oscillation noise will be a high-pitched tone. The oscillation may be stopped by increasing the time constant of the torque reference filter. Like the integral time constant, this filter causes a delay in the operation of the servo system. Therefore, this constant must not be set to an excessively large value.

- **Position Loop Gain (Pn102)**

The responsiveness of the servo system is determined by the position loop gain. The response speed increases if the position loop gain is set to a high value, so the time required for positioning will be shortened. In order to set the position loop gain to a high value, the rigidity and natural frequency of the mechanical system must be high.

The responsiveness of the whole servo system may become unstable if only the position loop gain is increased, because the speed reference as output from the position loop is likely to become unstable. Increase the speed loop gain while observing the response.

Adjustment Method

1. Set the position loop gain to a comparatively low value. Then increase the speed loop gain set in Pn100 to within a range where there is no noise or oscillation resulting.
2. Decrease the speed loop gain a little from the value set in step 1. Then increase the position loop gain to within a range where there is no overshooting or oscillation resulting.
3. Set the speed loop integral time constant in Pn101 while observing the positioning setting time and the vibration of the mechanical system. If the constant is too large, the positioning setting time will be too long.
4. Set the torque reference filter to a small value in Pn401 if the mechanical system has shaft torsion resonance. If the mechanical system generates oscillation noise in a high-pitched tone, shaft torsion resonance may be resulting. In that case, set Pn401 to a larger value.
5. Finally, progressively make fine adjustments to user constants such as the position loop gain, speed loop gain, and integral time constant to find the optimal points.

6 ■ Function to Improve Response Characteristics

The mode switch, feed-forward, and bias functions can improve the response characteristics of the servo system only if they are used properly. If they are used improperly, they will worsen the response characteristics. Refer to the following instructions and make adjustments to these functions while observing the change in the actual response characteristics.

Mode Switch

Use the mode switch function in order to improve the saturation characteristics of the servo system if there is torque reference saturation at the time of acceleration or deceleration of the Servomotor. If an appropriate value is set with this function, the speed loop in PI (proportional and integral) control is switched over to P (proportional) control when the operation speed exceeds the set value.

Feed-forward Functions

The responsiveness is increased by using one of the feed-forward functions. A feed-forward function is not so effective, however, if the position loop gain is set to a high enough value. Adjust the feed-forward set value of Pn109 as described below.

1. Adjust the speed loop and position loop according to the method described on page 6 -30.
2. Gradually increase the set value of Pn109 so that the positioning completion signal (/COIN) will be output quickly.

Make sure that the positioning completion signal (/COIN) is not broken (i.e., turned on and off repeatedly within a short period) and that speed overshooting does not result. These are likely to occur if the feed-forward value is too high.

It is possible to add a primary delay filter (to be set in Pn10A) to the feed-forward function. The primary delay filter may prevent the positioning completion signal from breaking and the system speed from overshooting.

Bias Function

This function adds the bias set in Pn107 to the output (i.e., speed reference) of the error counter if the number of accumulated pulses of the error counter exceeds the bias increment width set in Pn108 and stops adding the bias if the output is within the bias increment width. As a result, the number of accumulated pulses of the error counter decreases and the time required for positioning can be shortened.

If the bias set value of Pn107 is too large, the motor rotation will be unstable. The optimum bias value varies with the load, gain, and bias increment width. Make bias adjustments while observing the response. When not using this function, set Pn107 to 0.

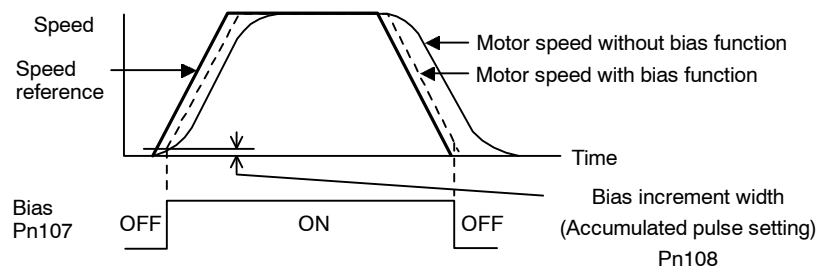

6.4.4 Gain Setting Reference Values

This section describes information on servo gain values as reference for making gain adjustments.

Refer to the following for standards for gain adjustments according to the rigidity of the mechanical system. Refer to these values and use the previously mentioned methods to make gain adjustments. These values are for reference only and do not mean that the mechanical system has good response characteristics or is free from oscillation in the specified ranges.

Observe the response by monitoring the response waveform and make the optimum gain adjustments. If the rigidity of the machinery is high, further gain increments exceeding the described ranges are possible.

■ Machines with High Rigidity

These machines are directly connected to ball screws.

Example: Chip mounting machine, bonding machine, high-precision machine tool

Position Loop Gain (Pn102) [1/s]	Speed Loop Gain (Pn100) [Hz]	Speed Loop Integral Time Constant (Pn101) [ms]
50 to 70	50 to 70	5 to 20

■ Machines with Medium Rigidity

These machines are driven by ball screws through speed reducers or long-length machines directly driven by screws.

Example: General machining tool, transverse robot, and conveyor

Position Loop Gain (Pn102) [1/s]	Speed Loop Gain (Pn100) [Hz]	Speed Loop Integral Time Constant (Pn101) [ms]
30 to 50	30 to 50	10 to 40

■ Machines with Low Rigidity

These machines are driven by timing belts or chains or machines with wave reduction gears.

Example: Conveyor and articulated robot

Position Loop Gain (Pn102) [1/s]	Speed Loop Gain (Pn100) [Hz]	Speed Loop Integral Time Constant (Pn101) [ms]
10 to 20	10 to 20	50 to 120

IMPORTANT

If the inertia ratio is a little larger than 10, start gain adjustments with the position and speed loop gains slightly below the above corresponding ranges and the speed loop integral constant slightly exceeding the above corresponding range. If the inertia ratio is much larger, start the gain adjustments with the position and speed loop gains set to the smallest values and the speed loop integral constant to the largest value in the above corresponding ranges.

In speed control operation, the position loop gain is set through the host device. If that is not possible, adjust the position loop gain with the speed reference input gain in Pn300 in the Servopack. In speed control operation, the position loop gain set in Pn102 is enabled in zero-clamp mode only. Position loop gain K_p is obtainable from the following.

$$K_p \square \frac{V_s}{\epsilon}$$

- K_p (1/S): Position Loop Gain
- V_s (PPS): Constant Speed Reference
- ϵ (Pulse): Constant error: The number of accumulated pulses of the error counter at the above constant speed.

6.5 Analog Monitor

The analog monitor can observe a variety of signals through analog voltages.

Analog monitor signals must be observed through the CN5 connector using DE9404559 dedicated cable.

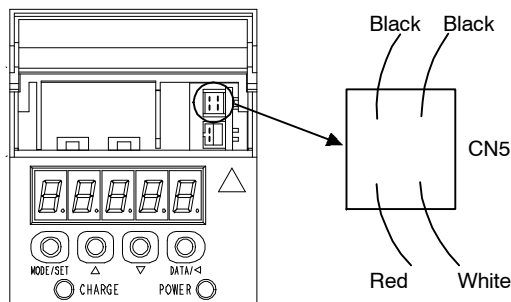

Cable Color	Signal Name	Description
White	Analog monitor 1	Torque reference: 1 V/100% rated torque
Red	Analog monitor 2	Motor r/min: 1 V/1000 r/min
Black (two wires)	GND(0 V)	-

Analog monitor signals can be selected with user constants Pn003.0 and Pn003.1.

Pn003.0	Analog Monitor 1	Factory Setting: 2	Speed/Torque Control, Position Control
Pn003.1	Analog Monitor 2	Factory Setting: 0	Speed/Torque Control, Position Control

The following monitor signals can be observed.

Settings in Pn003.0 and Pn003.1	Description	
	Monitor signal	Observation gain
0	Motor r/min	1 V/1000 r/min
1	Speed reference	1 V/1000 r/min
2	Torque reference	1 V/100% rated torque
3	Position error	0.05 V/1 reference unit
4	Position error	0.05 V/100 reference unit
5	Reference pulse frequency (converted to r/min)	1 V/1000 r/min
6	Motor r/min	1 V/250 r/min
7	Motor r/min	1 V/125 r/min
8 to E	Reserved monitor signal	-

Note In the case of torque control or speed control, the monitor signal of position error monitor signal is indefinite.



The output voltage of the analog monitor is ± 8 V max. The output voltage will be reversed if ± 8 V is exceeded.



7

Using the Digital Operator

This chapter describes the basic operation of the Digital Operator and the features it offers. All constant settings and motor operations can be executed by simple, convenient operations. Operate the Digital Operator as you read through this chapter.

7.1 Basic Operation	7 -2
7.1.1 Connecting the Digital Operator	7 -2
7.1.2 Functions	7 -3
7.1.3 Resetting Servo Alarms	7 -4
7.1.4 Basic Mode Selection	7 -5
7.1.5 Status Display Mode	7 -5
7.1.6 Operation in User Constant Setting Mode	7 -8
7.1.7 Operation in Monitor Mode	7 -14
7.2 Applied Operation	7 -19
7.2.1 Operation in Alarm Traceback Mode	7 -20
7.2.2 Controlling Operation Through the Digital Operator	7 -22
7.2.3 Automatic Adjustment of the Speed and Torque Reference Offset	7 -24
7.2.4 Manual Adjustment of the Speed and Torque Reference Offset	7 -27
7.2.5 Clearing Alarm Traceback Data	7 -31
7.2.6 Checking the Motor Model	7 -33
7.2.7 Checking the Software Version	7 -36
7.2.8 Origin Search Mode	7 -37
7.2.9 Initializing User Constant Settings	7 -39
7.2.10 Manual Zero Adjustment and Gain Adjustment of Analog Monitor Output	7 -41
7.2.11 Adjusting the Motor Current Detection Offset	7 -46
7.2.12 Password Setting (Write Prohibited Setting)	7 -50
7.2.13 Clearing Option Unit Detection Results	7 -52

7.1 Basic Operation

This section provides information on the basic operation of the Digital Operator for setting operating conditions.

7.1.1 Connecting the Digital Operator

There are two types of Digital Operator. One is a built-in operator incorporating a panel indicator and switches located on the front panel of the Servopack. This type of Digital Operator is also called a Panel Operator. The other one is a Hand-held Operator (i.e., the JUSP-OP02A-2 Digital Operator), which can be connected to the Servopack through connector CN3 of the Servopack.

There is no need to turn OFF the Servopack to connect this Hand-held Operator to the Servopack. Refer to the following illustrations to connect the Hand-held Digital Operator to the Servopack.

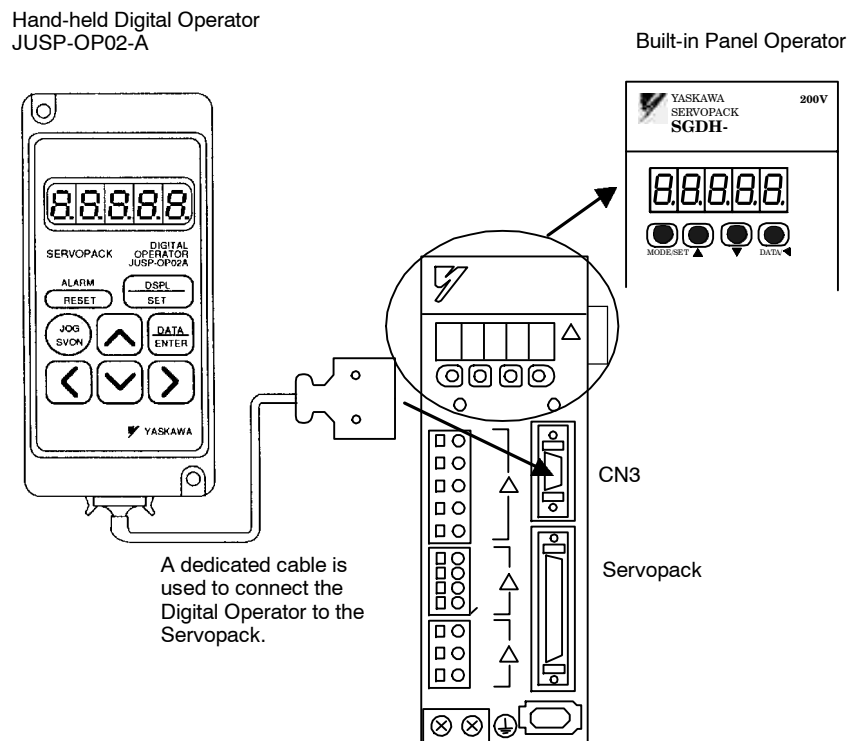

IMPORTANT

If the Hand-held Digital Operator is connected to the Servopack, the built-in Panel Operator does not display anything.

7.1.2 Functions

The Digital Operator can be used user constant settings, operating references, and status displays.

This section provides information on the keys and their functions available from the initial displays.

Hand-held Digital Operator

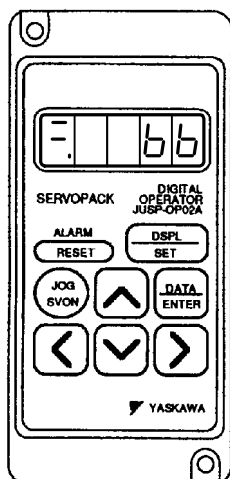

Key	Name		Function
	RESET Key		Press this key to reset the servo alarm.
	DSPL/SET Key		<ul style="list-style-type: none"> Press this key to select the status display mode, auxiliary function mode, user constant setting mode, or monitor mode. This key is used for data selection in user constant setting mode.
	DATA/ENTER Key		Press this key to set each user constant or display the set value of each user constant.
	Value Change/JOG Key	Up Cursor Key	Press this key to increase the set value. This key is used as a forward start key in JOG operation.
		Down Cursor Key	Press this key to decrease the set value. This key is used as a reverse start key in JOG operation.
	Digit Select Key	Right Cursor Key	<ul style="list-style-type: none"> Press this key to select the digit to be changed. The selected digit flashes. Press the Right Cursor Key to shift to the next digit on the right.
		Left Cursor Key	<ul style="list-style-type: none"> Press the Left Cursor Key to shift to the next digit on the left.
	SVON Key		Press this key to perform the JOG operation with the Digital Operator.

Built-in Panel Operator

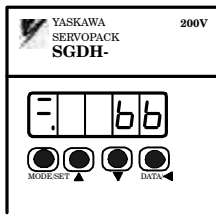

Key	Name	Function
	Up Cursor Key	<ul style="list-style-type: none"> Press this key to set user constants or display the set values of user constants. Press the Up Cursor Key to increase the set value.
	Down Cursor Key	<ul style="list-style-type: none"> Press the Down Cursor Key to decrease the set value. Press the Up and Down Cursor Keys together to reset a servo alarm.
	MODE/SET Key	Press this key to select the status indicator mode, auxiliary function mode, user constant setting mode, or monitor mode.
	DATA/SHIFT Key	<ul style="list-style-type: none"> Press this key to set each user constant or display the set value of each user constant. This key is used for selecting the editing (flashing) digit or data setting.

7.1.3 Resetting Servo Alarms

Servo alarms can be reset using the Digital Operator.

■ Using the Hand-held Digital Operator

Press the RESET Key in status display mode.

■ Using the Built-in Panel Operator

Press the Up and Down Cursor Keys together in status display mode.

The alarm can be reset with CN1-44, or /ALM-RST signal input. Refer to 5.5.1 *Using Servo Alarm and Alarm Code Outputs*.

The servo alarm need not be reset if the control power supply is turned OFF.

IMPORTANT

If an alarm is ON, reset the alarm after eliminating the cause of the alarm. Refer to 8.2 *Troubleshooting*.

7.1.4 Basic Mode Selection

The basic mode selection of the Digital Operator is used for indicating the status of the Servopack in operation and setting a variety of user constants and operation references.

The status display, auxiliary function, user constant setting, and monitor modes are the basic modes. As shown below, the mode is selected in the following order by pressing the key.

Hand-held Digital Operator

Press the DSPL/SET Key.
The basic mode changes.

Panel Operator

Press the MODE/SET Key.
The basic mode changes.

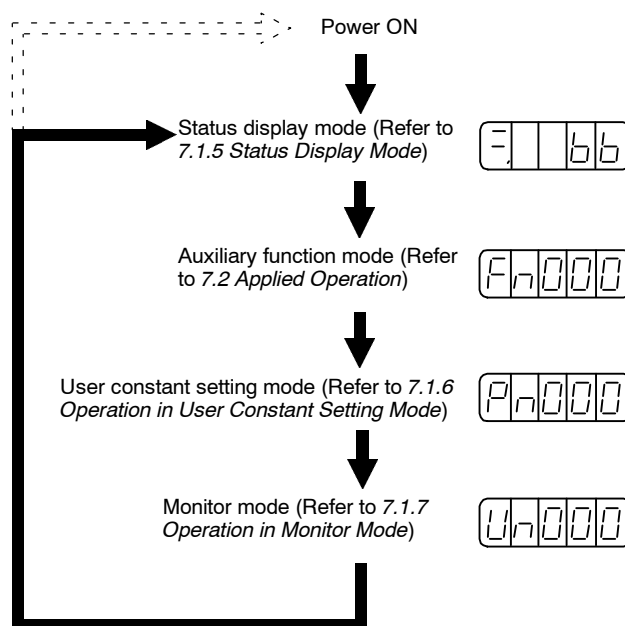

7.1.5 Status Display Mode

In status display mode, bit data and codes are displayed to indicate the status of the Servopack.

■ Selecting Status Display Mode

The Digital Operator goes into status display mode when the Digital Operation is turned ON.

■ Items Indicated in Status Display Mode

The displayed contents in the status display mode are different for the speed and torque control mode and the position control mode.

Speed and Torque Control Mode

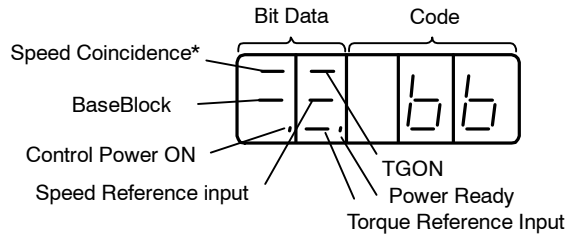

* This indicator is always lit when the Servopack is in torque control mode.

The following tables list bit data items, codes, and their meanings.

Table 7.1 Bit Data and Meanings in Speed and Torque Control Mode

Bit Data	Meaning
Control Power ON	Lit when Servopack control power is ON.
Baseblock	Lit for baseblock. Not lit when servo is ON.
Speed Coincidence	Lit when the difference between the motor speed and reference speed is the same as or less than the value set in Pn503. The standard value set in Pn503 is 10 r/min.
/TGON	Lit if motor speed exceeds preset value. Not lit if motor speed is below preset value. Preset value: Set in Pn502 (20 r/min is factory setting)
Speed Reference Input	Lit if input speed reference exceeds preset value. Not lit if input speed reference is below preset value. Specified value: Set in Pn502 (20 r/min is factory setting)
Torque Reference Input	Lit if input torque reference exceeds preset value. Not lit if input torque reference is below preset value. Preset value: 10% rated torque is standard setting
Power Ready	Lit when main power supply circuit is normal. Not lit when power is OFF.

Table 7.2 Codes and Meanings in Speed and Torque Control Mode

Code	Meaning
bb	Baseblock Servo OFF (motor power OFF)
run	Run Servo ON (motor power ON)
Pot	Forward Run Prohibited CN1-42 (P-OT) is OFF. Refer to 5.1.2 <i>Setting the Overtravel Limit Setting</i> .
not	Reverse Run Prohibited CN1-43 (N-OT) is OFF. Refer to 5.1.2 <i>Setting the Overtravel Limit Setting</i> .
A02	Alarm Status Displays the alarm number. Refer to 8.2 <i>Troubleshooting</i> .
A03	

Position Control Mode

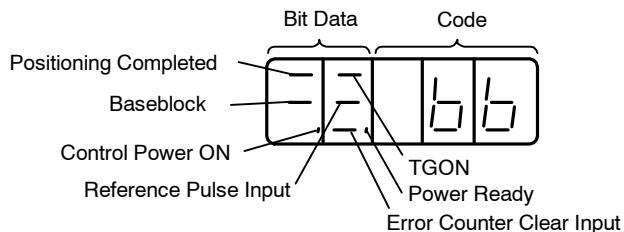

The following tables list bit data items, codes, and their meanings.

Table 7.3 Bit Data and Meanings in Position Control Mode

Bit Data	Meaning
Control Power ON	Lit when Servopack control power ON.
Baseblock	Lit for baseblock. Not lit at servo ON.
Positioning Completed	Lit if error between position reference and actual motor position is below preset value. Not lit if error between position reference and actual motor position exceeds preset value. Preset value: Set in PN500 (7 pulses are standard setting)
/TGON	Lit if motor speed exceeds preset value. Not lit if motor speed is below preset value. Preset value: Set in Pn502 (20 r/min is standard setting)
Reference Pulse Input	Lit if reference pulse is input Not lit if no reference pulse is input.
Error Counter Clear Input	Lit when error counter clear signal is input. Not lit when error counter clear signal is not input.
Power Ready	Lit when main power supply circuit is normal. Not lit when power is OFF.

Table 7.4 Codes and Meanings in Position Control Mode

Code	Meaning
bb	Baseblock Servo OFF (motor power OFF)
run	Run Servo ON (motor power ON)
Pot	Forward Run Prohibited CN1-42 (P-OT) is OFF. Refer to 5.1.2 <i>Setting the Overtravel Limit Setting</i> .
not	Reverse Run Prohibited CN1-43 (N-OT) is OFF. Refer to 5.1.2 <i>Setting the Overtravel Limit Setting</i> .
A02	Alarm Status Displays the alarm number. Refer to 8.2 <i>Troubleshooting</i> .
A03 :	

7.1.6 Operation in User Constant Setting Mode

Functions can be selected or adjusted by setting user constants. There are two types of user constants. One type requires value setting and the other requires function selection. These two types use different setting methods.

With value setting, a user constant is set to a value within the specified range of the user constant. With function selection, the functions allocated to each digit of the seven-segment LED panel indicator (five digits) can be selected. Refer to *Appendix B List of User Constants*.

■ Changing Constant Settings

The constant settings can be used for changing constant data. Check the permitted range of the constants in *Appendix LEERER MERKER List of User Constants*, before changing the data. The example below shows how to change user constant Pn507 from 100 to 85.

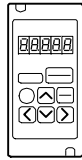

Using the Hand-held Digital Operator

1. Press DSPL/SET Key to select the user constant setting mode.

Pn0000

2. Select the user constant number to set. (Pn507 is selected in this example.)

Press the Left or Right Cursor Key to select the digit. The selected digit will flash.

Press the Up or Down Cursor Key to change the value.

3. Press the DATA/ENTER Key to display the current data for the user constant selected at step 2.

00100

4. Change to the required data.

Press the Left or Right Cursor Key to select the digit. The selected digit will flash.

Press the Up or Down Cursor Key to change the value. Continue pressing the key until "00085" is displayed.

5. Press the DATA/ENTER Key to store the data. The display will flash.

00085

6. Press the DATA/ENTER Key again to return to the user constant number display.

Pn507

This procedure has changed the setting of the user constant Pn507 from 100 to 85. Repeat steps 2. to 6. as often as required.



Using the Panel Operator

1. Press the MODE/SET Key to select the user constant setting mode.

Pn000

2. Press the Up or Down Cursor Key to select the user constant number to set. (Pn507 is selected in this example.)
3. Press the DATA/SHIFT Key for a minimum of one second to display the current data for the user constant selected in step 2.

00100

4. Press the Up or Down Cursor Key to change to the desired value of “00085”.
As you keep pressing the Up or Down Cursor Key, and the display changes faster.
5. Press the DATA/SHIFT Key for a minimum of one second to save the data. The display will flash.

00085

6. Press the DATA/SHIFT Key once more for a minimum of one second to display the user constant number again.

Pn507

This has changed the setting of the user constant Pn507 from 100 to 85.

Repeat steps 2. to 6. as often as required.

IMPORTANT

Press the DATA/SHIFT Key for a maximum of one second to shift to a higher (left) digit.



User constant numbers that are not defined are skipped during Operator operations.

■ Function Selection User Constants

Types of Function Selection User Constants

The following table shows user the constants used for selecting Servopack functions.

Category	User Constant No.	Name	Factory Setting	Remarks
Function Selection Constants	Pn000	Function Selection Basic Switches	0000	(See 1.)
	Pn001	Function Selection Application Switches 1	0000	(See 1.)
	Pn002	Function Selection Application Switches 2	0000	(See 1.)
	Pn003	Function Selection Application switches 3	0002	
Gain-related Constants	Pn10B	Gain-related Application Switches	0000	(See 2.)
	Pn110	Online Autotuning Switches	0010	(See 2.)
Position Control-related Constant	Pn200	Position Control Reference Selection Switches	0000	(See 1.)
Sequence-related Constants	Pn50A	Input Signal Selections 1	2100	(See 1.)
	Pn50B	Input Signal Selections 2	6543	(See 1.)
	Pn50C	Input Signal Selections 3	8888	(See 1.)
	Pn50D	Input Signal Selections 4	8888	(See 1.)
	Pn50E	Output Signal Selections 1	3211	(See 1.)
	Pn50F	Output Signal Selections 2	0000	(See 1.)
	Pn510	Output Signal Selections 3	0000	(See 1.)

IMPORTANT

1. After changing these user constants, turn OFF the main circuit and control power supplies and then turn them ON again to enable the new settings.
2. Pn10B.1 and Pn110.0 require the power to be reset as mentioned above.

User constant settings are displayed in two patterns as shown below.

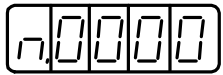
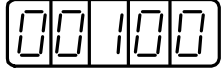
User constants for function selection		Hexadecimal display for each digit
User constants for constant settings		Decimal display in five digits

Since each digit in the function selection user constants has a significant meaning, the value can only be changed for each individual digit. Each digit displays a value within its own setting range.

Definition of Display for Function Selection User Constants

Each digit of the function selection user constants has a unique meaning.

For example, the rightmost digit of user constant Pn000 is expressed as “Pn000.0”.

IMPORTANT

Each digit of the function selection user constants is defined as shown below. The user constant display example shows how user constants are displayed in digits for set values.

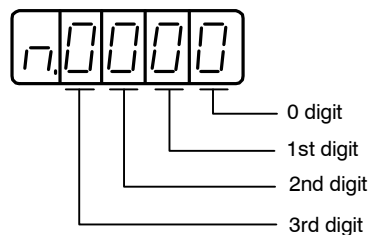

How to Display User Contents

- Pn000.0: Indicates the value for the 0 digit of user constant Pn000.
- Pn000.1: Indicates the value for the 1st digit of user constant Pn000
- Pn000.2: Indicates the value for the 2nd digit of user constant Pn000
- Pn000.3: Indicates the value for the 3rd digit of user constant Pn000

■ Changing Function Selection User Constant Settings

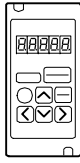

Using the Hand-held Digital Operator

1. Press the DSPL/SET Key to select the constant setting mode.



2. Select the user constant number to be set.

Press the Left or Right Cursor Key to select the digit. The selected digit will flash. Press the Up or Down Cursor Key to change the value. (Pn000 is selected in this example.)

3. Press the DATA/ENTER Key to display the current data of the user constant selected in the above step 2.

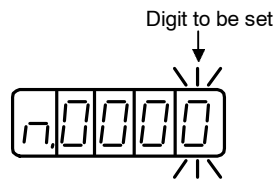

4. Press the Left or Right Cursor Key to select the digit.

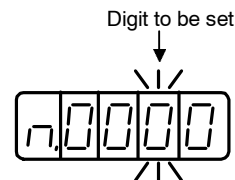

5. Press the Up or Down Cursor Key to select the value defined as a function setting for the selected digit.

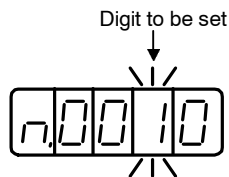

Repeat the above steps 4. and 5. for changing the data as required.

6. Press the DATA/ENTER Key to save the data. The display will flash.



7. Press the DATA/ENTER Key once more to return to the user constant number display.



This has changed the 1st digit of user constant Pn000 to "1".



Using the Panel Operator

1. Press the MODE/SET Key to select the constant setting mode.



2. Press the Up or Down Cursor Key to select the user constant number to be set. (Pn000 is selected in this example.)
3. Press the DATA/SHIFT Key for a minimum of one second to display the current data for the selected user constant.

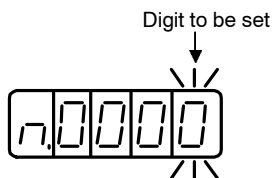

4. Press the DATA/SHIFT Key to select the digit to be set.

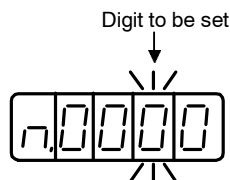

5. Press the Up or Down Cursor Key to select the value defined as a function setting for the selected digit.

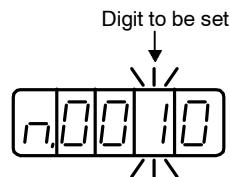

Repeat the above steps 4. and 5. for changing the data as required.

6. Press the DATA/SHIFT Key for a minimum of one second to save the data. The display will flash.



7. Press the DATA/SHIFT Key once more for a minimum of one second to return to the user constant number display.



This has changed the 1st digit of user constant Pn000 to "1".

7.1.7 Operation in Monitor Mode

The monitor mode can be used for monitoring the reference values, I/O signal status, and Servo-pack internal status.

The monitor mode can be set during motor operation.

■ Using the Monitor Mode

The example below shows how to display 1500, the contents of monitor number Un000 when the Servomotor rotates at 1500 r/min.

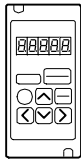

With the Hand-held Digital Operator

1. Press the DSPL/SET Key to select the monitor mode.

Un000

2. Press the Up or Down Cursor Key to select the monitor number to be displayed.
3. Press the DATA/ENTER Key to display the monitor number selected in the above step 2.

Data
1500

4. Press the DATA/ENTER Key once more to return to the monitor number display.

Un000

This is how to display 1500, the contents of monitor number Un000.



With the Panel Operator

1. Press the MODE/SET Key to select the monitor mode.

Un000

2. Press the Up or Down Cursor Key to select the monitor number to be displayed.
3. Press the DATA/SHIFT Key for a minimum of one second to display the monitor number selected in the above step 2.

Data
1500

4. Press the DATA/SHIFT Key once more for a minimum of one second to return to the monitor number display.

Un000

This completes the example procedure for displaying 1500, the contents of monitor number Un000.

■ Contents of Monitor Mode Display

The following table shows contents of the monitor mode display.

Monitor Number	Monitor Display	Unit	Remarks
Un000	Actual motor speed	r/min	
Un001	Input speed reference	r/min	*3
Un002	Internal torque reference	%	Value for rated torque
Un003	Rotation angle 1	pulses	Number of pulses from the origin
Un004	Rotation angle 2	deg	Angle (electrical angle) from the origin
Un005	Input signal monitor	-	*1
Un006	Output signal monitor	-	*1
Un007	Input reference pulse speed	r/min	*4
Un008	Error counter value	reference unit	Positional error *4
Un009	Accumulated load rate	%	Value for the rated torque as 100% Displays effective torque in 10 cycle.
Un00A	Regenerative load rate	%	Value for the processable regenerative power as 100% Displays regenerative consumption power in 10 cycle.
Un00B	Power consumed by DB resistance	%	Value for the processable power when dynamic brake is applied as 100% Displays DB power consumption in 10-s cycle.
Un00C	Input reference pulse counter	-	In hexadecimal*2, *4
Un00D	Feedback pulse counter	-	In hexadecimal

* 1. Refer to *Sequence I/O Signal Monitor* on the next page.

* 2. Refer to *Reference Pulse/Feedback Pulse Counter Monitor Display*.

* 3. Displayed only in speed control mode.

* 4. Displayed only in position control mode.

Sequence I/O Signal Monitor Display

The following section describes the monitor display for sequence I/O signals.

Input Signal Monitor Display



LED Number	Input Terminal Name	Factory Setting
1	SI0 (CN1-40)	/S-ON
2	SI1 (CN1-41)	/P-CON
3	SI2 (CN1-42)	P-OT
4	SI3 (CN1-43)	N-OT
5	SI4 (CN1-44)	/ALM-RST
6	SI5 (CN1-45)	/P-CL
7	SI6 (CN1-46)	/N-CL
8	(CN1-4)	SEN

Note Refer to 5.3.3 *Input Circuit Signal Allocation* for details on input terminals.

Input signals are allocated as shown above and displayed on the panel display of the Servopack or the Digital Operator. They are indicated by ON/OFF display of seven-segment LEDs in top and bottom rows. These segments turn ON depending on the input signals (ON for “L” level and OFF for “H” level).

7

EXAMPLE

- When /S-ON signal is ON (Servo ON at “L” signal)

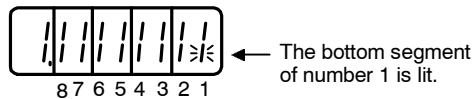

- When /S-ON signal is OFF

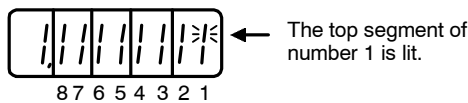

- When P-OT signal operates (Operates at “H” signal)

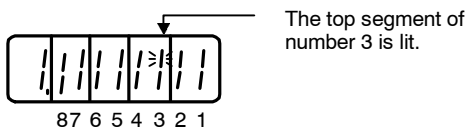

Output Signal Monitor Display



LED Number	Output Terminal Name	Factory Setting
1	(CN1-31, -32)	ALM
2	SO1 (CN1-25, -26)	/COIN or /V-CMP
3	SO2 (CN1-27, -28)	/TGON
4	SO3 (CN1-29, -30)	/S-RDY
5	(CN1-37)	AL01
6	(CN1-38)	AL02
7	(CN1-39)	AL03

Note Refer to 5.3.4 *Output Circuit Signal Allocation* for details on output terminals.

Output signals are allocated as shown above and displayed on the panel display of the Servopack or the Digital Operator. They are indicated by ON/OFF display of seven-segment LEDs in top and bottom rows. These segments turn ON depending on the output signals (ON for "L" level and OFF for "H" level).

◀EXAMPLE▶

- When ALM signal operates (alarm at "H")

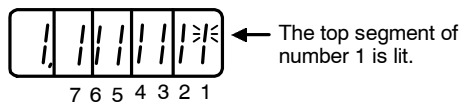

■ Reference Pulse/Feedback Pulse Counter Monitor Display

The monitor display of reference pulse counter and feedback pulse counter is expressed in 32-bit hexadecimal.

The display procedure is as follows:

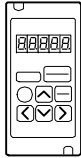

Using the Hand-held Digital Operator

1. Press the DSPL/SET Key to select the monitor mode.
2. Press the Up or Down Cursor Key to select “Un00C” or “Un00D”.
3. Press the DATA/ENTER Key to display the data for the monitor number selected in the above step.

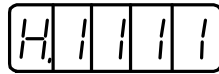

4. Press the Up or Down Cursor Key to alternately display the leftmost 16-bit data and rightmost 16-bit data.

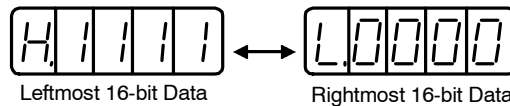

5. Press both the Up and Down Cursor Keys simultaneously to clear the 32-bit counter data.
6. Press the DATA/ENTER Key once more to return to the monitor number display.

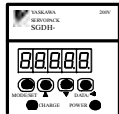

Using the Panel Operator

1. Press the MODE/SET Key to select the monitor mode.
2. Press the Up or Down Cursor Key to select “Un00C” or “Un00D”.
3. Press the DATA/SHIFT Key for a minimum of one second to display the data for the monitor number selected in the above step.

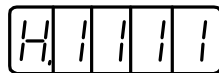

4. Press the Up or Down Cursor Key to alternately display the leftmost 16-bit data and rightmost 16-bit data.

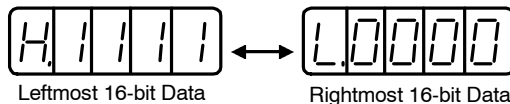

5. Press both the Up and Down Cursor Keys simultaneously to clear the 32-bit counter data.
6. Press the DATA/SHIFT Key once more for a minimum of one second to return to the monitor number display.

7.2 Applied Operation

This section describes how to apply the basic operations using the Digital Operator to run and adjust the motor. Read the basic operations described in *section 7.1* before proceeding to this section.

User constants for applied operation can be set in the auxiliary function mode. The following table shows the user constants in the auxiliary function mode.

User Constant Number	Function	Remarks
Fn000	Alarm traceback data display	
Fn001	Rigidity setting during online autotuning	(See note.)
Fn002	JOG mode operation	
Fn003	Zero-point search mode	
Fn004	(Reserved constant)	
Fn005	User constant settings initialization	(See note.)
Fn006	Alarm traceback data clear	(See note.)
Fn007	Writing inertia ratio data obtained from online autotuning to EEPROM	(See note.)
Fn008	Absolute encoder multi-turn reset and encoder alarm reset.	(See note.)
Fn009	Automatic tuning of analog (speed, torque) reference offset	(See note.)
Fn00A	Manual adjustment of speed reference offset	(See note.)
Fn00B	Manual adjustment of torque reference offset	(See note.)
Fn00C	Manual zero-adjustment of analog monitor output	(See note.)
Fn00D	Manual gain-adjustment of analog monitor output	(See note.)
Fn00E	Automatic offset-adjustment of motor current detection signal	(See note.)
Fn00F	Manual offset-adjustment of motor current detection signal	(See note.)
Fn010	Password setting (protects from user constant changes)	-
Fn011	Motor models display	-
Fn012	Software version display	-
Fn013	Multiturn limit value setting change when a Multiturn Limit Disagreement alarm occurs	(See note.)
Fn014 *	Clear of option unit detection results	

* User constant Fn014 is supported by the new version of SGD Servopacks only.

Note These user constants and those indicated as Pn□□□ are displayed as shown below if their passwords are set (Fn010). These user constants cannot be changed.



7.2.1 Operation in Alarm Traceback Mode

The alarm traceback mode can display up to ten alarms that have occurred, thus making it possible to check what kind of alarms have been generated.

The alarm traceback data is not cleared on alarm reset or when the Servopack power is turned OFF. This does not adversely affect operation.

The data can be cleared using the special “clear alarm traceback mode.” Refer to *Section 7.2.5 Clearing Alarm Traceback Data* for details.

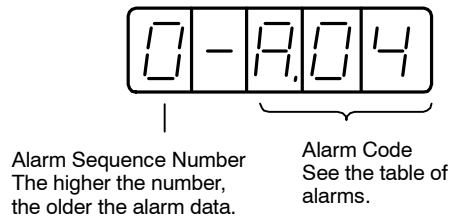

■ Checking Alarms

Follow the procedure below to determine which alarms have been generated.

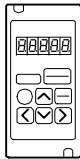

Using the Hand-held Digital Operator

1. Press the DSPL/SET Key to select the “Displaying alarm traceback data (Fn000)” in the auxiliary function mode.



2. Press the DATA/ENTER Key, and the alarm traceback data will be displayed.
3. Press the Up Cursor Key or Down Cursor Key to scroll the alarm sequence numbers up or down and display information on previous alarms.

The higher the left-hand digit (alarm sequence number), the older the alarm data.



Using the Panel Operator

1. Press the MODE/SET Key to select the “Displaying alarm traceback data (Fn000)” in the auxiliary function mode.

 Alarm Traceback
Display

2. Press the DATA/SHIFT for a minimum of one second to display the alarm traceback data.
3. Press the Up Cursor Key or Down Cursor Key to scroll the alarm sequence numbers up or down and display information on previous alarms.

The higher the left-hand digit (alarm sequence number), the older the alarm data.

For descriptions of each alarm code, refer to *Section 8.2 Troubleshooting*.

The following are Operator-related alarms which are not recorded in the traceback data.

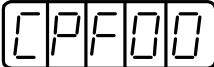
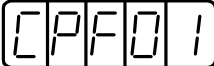
	Digital Operator transmission error 1
	Digital Operator transmission error 2

The display will be as shown below while no alarm is detected.

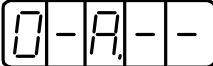

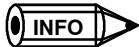

Alarm traceback data will not be updated when the same alarm occurs repetitively.

7.2.2 Controlling Operation Through the Digital Operator

⚠ CAUTION

- Forward run prohibited (P-OT) and reverse run prohibited (N-OT) signals are not effective during jog operations using user constant Fn002.

Controlling operation through the Digital Operator allows the Servopack to run the motor. This allows rapid checking of motor's rotation direction and speed setting during machine set-up and testing, without the trouble of connecting a host controller.

For motor speed setting procedure, refer to 7.1.6 *Operation in User Constant Setting Mode* and 5.3.2 *Setting JOG Speed*.

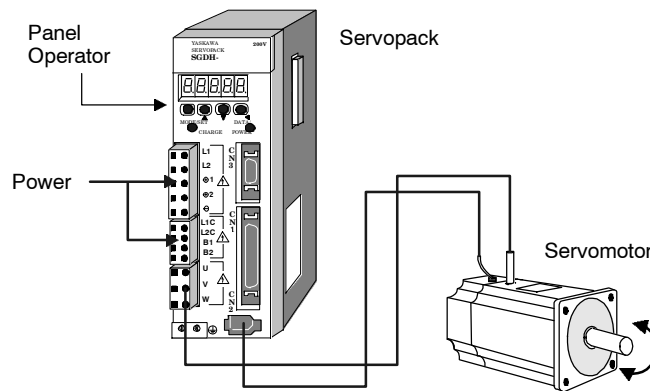

The following conditions must be satisfied to perform JOG mode operation.

- If the Servo-ON input signal (/S-ON) is ON, turn it OFF.
- Release the Servo-ON signal mask if user constant Pn50A.1 is set to 7, and the Servo has been set to always be ON.

Operation procedure using the Digital Operator is described on the following pages.

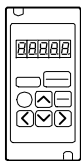

Using the Hand-held Digital Operator

1. Press the DSPL/SET Key to select Fn002 in the auxiliary function mode.

Fn002

2. Press the DATA/ENTER Key to select the Digital Operator operation mode. Operation is now possible using the Digital Operator.

F. J000

3. Press the SVON key to set to the servo ON state (with motor power turned ON).

- J000

4. Press the Up Cursor Key or Down Cursor Key to operate the motor. The motor keeps operating while the key is pressed.

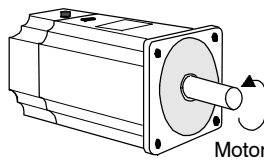

Motor Forward
Rotation

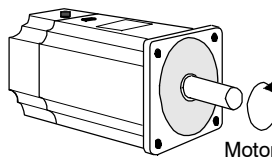

Motor Reverse
Rotation

5. Press the DSPL/SET Key, and the display will revert to Fn002. This sets to the servo OFF state (with motor power turned OFF). Alternatively, press the SVON Key to set to the servo OFF state.

Fn002

This disables operation under Digital Operator control.



Using the Panel Operator

1. Press the MODE/SET Key to select Fn002 in the auxiliary function mode.

Fn002

2. Press the DATA/SHIFT Key for a minimum of one second to select the Panel Operator operation mode. Operation is now possible using the Panel Operator.

F. J000

3. Press the MODE/SET Key to set to the servo ON (with motor power turned ON).

- J000

4. Press the Up Cursor Key or Down Cursor Key to operate the motor. The motor keeps operating while the key is pressed.

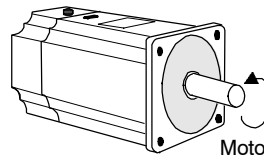

Motor Forward
Rotation

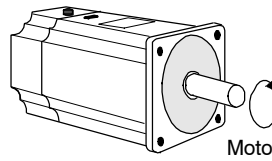

Motor Reverse
Rotation

5. Press the MODE/SET Key to set to the servo OFF state (with motor power turned OFF). Alternatively, press the DATA/SHIFT Key for a minimum of one second to set to the servo OFF state.
6. Press the DATA/SHIFT Key for a minimum of one second, and the display will revert to Fn002 in the auxiliary function mode.

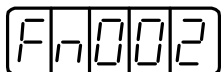

This ends operation under Panel Operator control.

The motor speed for operation under Digital Operator control can be changed with a user constant:

User constant: Pn304, Unit: r/min. Standard setting: 500



The rotation direction of the Servomotor depends on the setting of user constant Pn000.0 "Rotation Direction." The above example shows a case where Pn000.0 is set to "0". as a factory setting.

7.2.3 Automatic Adjustment of the Speed and Torque Reference Offset

When speed and torque control are used, the motor may rotate slowly even when 0 V is specified as the analog reference voltage. This occurs when the host controller or external circuit has a small offset (measured in mV) in the reference voltage.

The reference offset automatic adjustment mode automatically measures the offset and adjusts the reference voltage. It adjusts both the speed and torque references.

The following diagram illustrates automatic adjustment of an offset in the reference voltage by the Servopack.

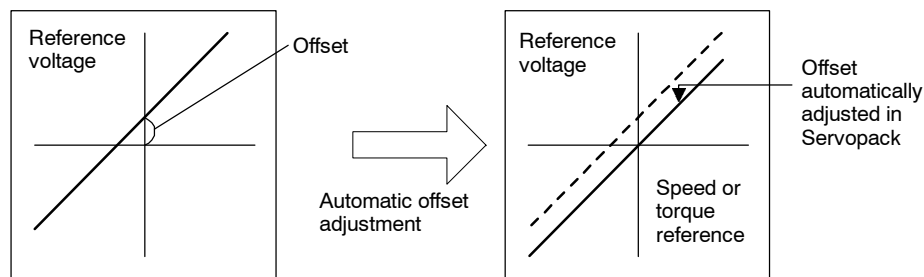

After completion of offset automatic adjustment, the amount of offset is stored in the Servopack.

The amount of offset can be checked in the speed reference offset manual adjustment mode. Refer to *Section 7.2.4 Manual Adjustment of the Speed and Torque Reference Offset* for details.

The reference offset automatic adjustment mode cannot be used for setting the error pulses to zero for a stopped Servopack when a position loop is formed with a host controller. In such cases, use the reference offset manual adjustment mode. Refer to *Section 7.2.4 Manual Adjustment of the Speed and Torque Reference Offset* for details.

The zero-clamp speed control function is available to force the motor to stop while the zero speed reference is given. Refer to *Section 5.4.3 Using the Zero Clamp Function*.

IMPORTANT

Automatic adjustment of the speed/torque reference offset must be performed under the servo OFF state.

Follow the procedure below to automatically adjust the speed/torque reference offset.

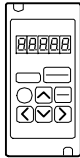
**Using the Hand-held Digital Operator**

1. Input the (intended) 0 V reference voltage from the host controller or external circuit.

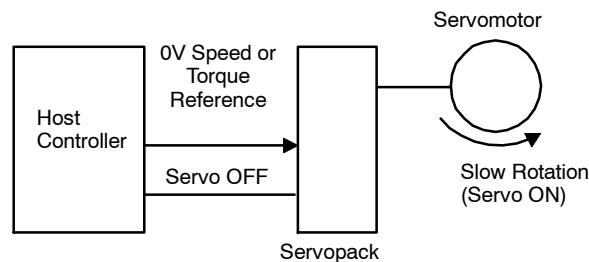

2. Press the DSPL/SET Key to select the auxiliary function mode.

`Fn000`

3. Select the user constant Fn009.

`Fn009`

Press the Left or Right Cursor Key to select the digit.

Press the Up or Down Key to change the value.

4. Press the DATA/ENTER Key, and the display will be as shown below.

`rEFLo`

5. Press the DSPL/SET Key, and the following display will flash for one second. The reference offset will be automatically adjusted.

`done` Flashing for one second → `rEFLo`

6. Press the DATA/ENTER Key to return to the auxiliary function mode display.

`Fn009`

This completes the speed/torque reference offset automatic adjustment.



Using the Panel Operator

1. Input the (intended) 0V reference voltage from the host controller or external circuit.

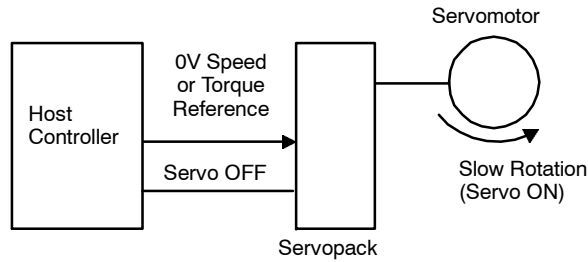

2. Press the MODE/SET Key to select the auxiliary function mode.



3. Press the Up or Down Cursor Key to select the user constant Fn009.



4. Press the DATA/SHIFT Key for a minimum of one second, and the display will be as shown below.

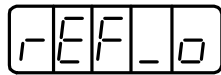

5. Press the MODE/SET Key, and the following display will flash for one second. The reference offset will be automatically adjusted.

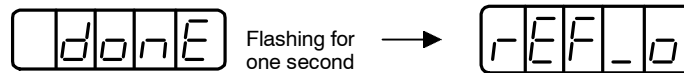

6. Press the DATA/SHIFT Key for a minimum of one second to return to the auxiliary function mode display.

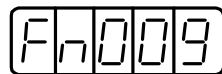

This completes the speed/torque reference offset automatic adjustment.

7

7.2.4 Manual Adjustment of the Speed and Torque Reference Offset

Speed/torque reference offset manual adjustment is very convenient in the following situations:

- If a loop is formed with the host controller and the error is zeroed when servo lock is stopped.
- To deliberately set the offset to some value.

This mode can also be used to check the data set in the reference offset automatic adjustment mode.

In principle, this mode operates in the same way as the reference offset automatic adjustment mode, except that the amount of offset is directly input during the adjustment. The offset amount can be set in the speed reference or torque reference.

The offset setting range and setting units are as follows:

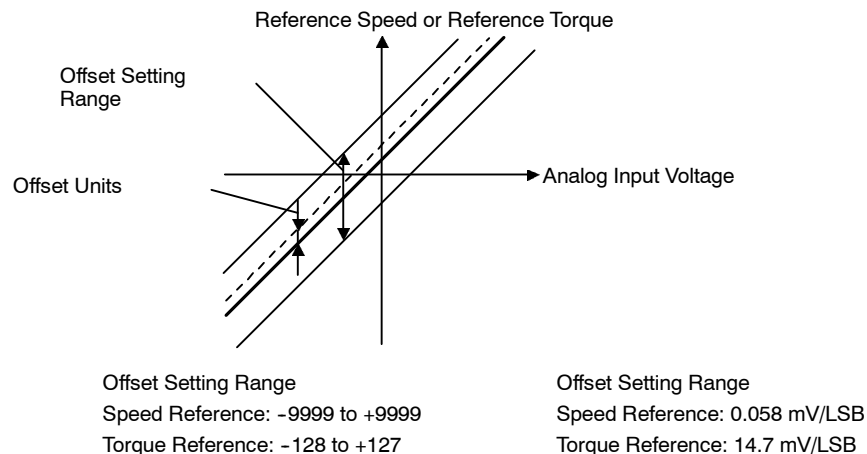

■ Speed Reference Offset Manual Adjustment

Follow the procedure below to manually adjust the speed reference offset.

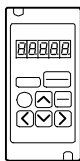

Using the Hand-held Digital Operator

1. Press the DSPL/SET Key to select the auxiliary function mode.

Fn000

2. Select the user constant Fn00A.

Press the Left or Right Cursor Key to select the digit.

Press the Up or Down Cursor Key to change the value.

Fn00A

3. Press the DATA/ENTER Key, and the display will be as shown below. The manual adjustment mode for the speed reference offset will be entered.

-.SPd

4. Turn ON the Servo ON (/S-ON) signal. The display will be as shown below.



5. Press the Left or Right Cursor Key, to display the speed reference offset amount.



6. Press the Up or Down Cursor Key to adjust the amount of offset (adjustment of the speed reference offset).
7. Press the Right Cursor Key to return to the display shown in the above step 4.
8. Press the DATA/ENTER Key to return to the auxiliary function mode display.

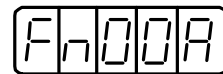

This completes the speed reference offset manual adjustment.



Using the Panel Operator

1. Press the MODE/SET Key to select the auxiliary function mode.

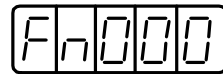

2. Press the Up or Down Cursor Key to select the user constant Fn00A.



3. Press the DATA/SHIFT Key for a minimum of one second, and the display will be as shown below. The manual adjustment mode for the speed reference offset will be entered.

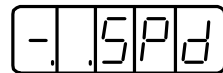

4. Turn ON the Servo ON (/S-ON) signal. The display will be as shown below.

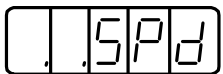

5. Press the DATA/SHIFT Key for less than one second to display the speed reference offset amount.



6. Press the Up or Down Cursor Key to adjust the amount of offset (adjustment of the speed reference offset).
7. Press the DATA/SHIFT Key for less than one second to return to the display shown in the above step 4.
8. Press the DATA/SHIFT Key to return to the auxiliary function mode display.



This completes the speed reference offset manual adjustment.

■ Torque Reference Offset Manual Adjustment

Follow the procedure below to manually adjust the torque reference offset.

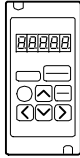

Using the Hand-held Digital Operator

1. Press the DSPL/SET Key to select the auxiliary function mode.

F_n0000

2. Select the user constant F_n00B.

Press the Left or Right Cursor Key to select the digit.

Press the Up or Down Cursor Key to change the value.

F_n000b

3. Press the DATA/ENTER Key, and the display will be as shown below. The manual adjustment mode for the torque reference offset will be entered.

- . . t r 9

4. Turn ON the Servo ON (/S-ON) signal. The display will be as shown below.

. . t r 9

5. Press the Left or Right Cursor Key to display the torque reference offset amount.

00000

6. Press the Up or Down Cursor Key to adjust the offset amount (adjustment of torque reference offset).

7. Press the Left or Right Cursor Key, and the display will be as shown in the above step 4.

8. Press the DATA/ENTER Key to return to the auxiliary function mode display.

F_n000b

This completes the torque reference offset manual adjustment.

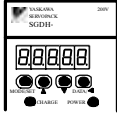

Using the Panel Operator

1. Press the MODE/SET Key to select the auxiliary function mode.

F_n000

2. Press the Up or Down Cursor Key to select the user constant F_n00B.

F_n00b

3. Press the DATA/SHIFT Key for a minimum of one second, and the display will be as shown below. The manual adjustment mode for the torque reference offset will be entered.

- . 1 9

4. Turn ON the Servo ON (/S-ON) signal. The display will be as shown below.

. . 1 9

5. Press the DATA/SHIFT Key for less than one second, to display the torque reference offset amount.

- 0 0 0 0

6. Press the Up or Down Cursor Key to adjust the offset amount. (Adjustment of torque reference offset)
7. Press the DATA/SHIFT Key for less than one second, and the display will be as shown in the above step 4.
8. Press the DATA/SHIFT Key to return to the auxiliary function mode.

F_n00b

This completes the torque reference offset manual adjustment.

7.2.5 Clearing Alarm Traceback Data

This procedure clears the alarm history, which stores the alarms generated in the Servopack. Each alarm in the alarm history is set to A.- -, which is not an alarm code. Refer to *Section 7.2.1 Operation in Alarm Traceback Mode* for details.

Follow the procedure below to clear the alarm traceback data.

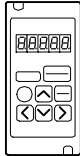

Using the Hand-held Digital Operator

1. Press the DSPL/SET Key to select the auxiliary function mode.

F_n000

2. Select the user constant Fn006.

Press the Left or Right Cursor Key to select the digit.

Press the Up or Down Cursor Key to change the value.

F_n006

3. Press the DATA/ENTER Key, and the display will be as shown below.

ErCLr

4. Press the DSPL/SET Key to clear the alarm traceback data. The following display will flash for one second, and, after the alarm traceback data is cleared, the display will return to the one in the above step 3.

done → ErCLr

Flashing for one second

5. Press the DATA/ENTER Key to return to the user constant code display.

F_n006

This completes the alarm traceback data clearing procedure.



Using the Panel Operator

1. Press the MODE/SET Key to select the auxiliary function mode.

Fn000

2. Press the Up or Down Cursor Key to select the user constant Fn006.

Fn006

3. Press the DATA/SHIFT Key for a minimum of one second, and the display will be as shown below.

ErCLr

4. Press the MODE/SET Key to clear the alarm traceback data. The following display will flash for one second, and, after the alarm traceback data is cleared, the display will return to the one in the above step 3.

done → ErCLr

Flashing for one second

5. Press the DATA/SHIFT Key for a minimum of one second to return to the user constant code display.

Fn006

This completes the alarm traceback data clearing procedure.

7.2.6 Checking the Motor Model

Set the user constant Fn011 to select the motor model check mode. This mode is used for motor maintenance, and can also be used to check the specification codes of Servopacks made with special specifications.

Follow the procedure below to check the motor model.

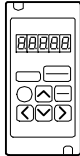

Using the Hand-held Digital Operator

1. Press the DSPL/SET Key to select the auxiliary function mode.

Fn000

2. Select the user constant Fn011.
Press the Left or Right Cursor Key to select the digit.
Press the Up or Down Key to change the value.

Fn011

3. Press the DATA/ENTER Key to display the Servomotor model and voltage code.

F.0100

Voltage Servomotor Model

Voltage

Code	Voltage
00	100 VAC or 140 VDC
01	200 VAC or 280 VDC
02	400 VAC or 560 VDC

Servomotor Model

Code	Servomotor Model
00	SGMAH
01	SGMPH
02	SGMSH
03	SGMGH-□A (1500 r/min)
04	SGMGH-□B (1000 r/min)
05	SGMDH
06	SGMUH

4. Press the DSPL/SET Key to display the Servomotor capacity.

P.0010

Capacity: Displayed value × 10 (W)
In this example, the capacity is 100 W.

5. Press the DSPL/SET Key to display the encoder type and resolution code.

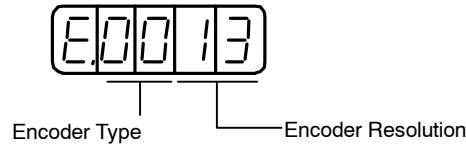

Encoder Type

Code	Type
00	Incremental encoder
01	Absolute encoder

Encoder Resolution

Code	Resolution
13	13 bits
16	16 bits
17	17 bits
20	Reserved

6. Press the DSPL/SET Key to display the Servopack's special specification code (Y-specification code).

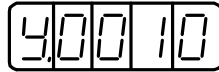

This example shows specification code "Y10" (Indicated in decimal).

7. Press the DATA/ENTER Key to return to the auxiliary function mode display. Pressing the DATA/ENTER Key after the above display 3. to 5. will also return to the auxiliary function mode display.

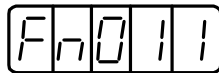

This ends checking motor type procedure.



Using the Panel Operator

1. Press the MODE/SET Key to select the auxiliary function mode.

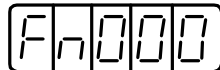

2. Press the Up or Down Cursor Key to select the user constant Fn011.

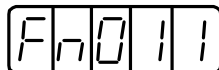

3. Press the DATA/SHIFT Key for a minimum of one second to display the Servomotor model and voltage code.

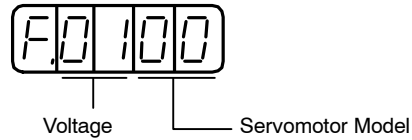
**Voltage**

Code	Voltage
00	100 VAC or 140 VDC
01	200 VAC or 280 VDC
02	400 VAC or 560VDC

Servomotor Model

Code	Servomotor Model
00	SGMAH
01	SGMPH
02	SGM5H
03	SGMGH-□A (1500 r/min)
04	SGMGH-□B (1000 r/min)
05	SGMDH
06	SGMUH

4. Press the MODE/SET Key to display the Servomotor capacity.

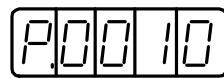

Capacity unit: Displayed value × 10 [W]
This example shows 100 W.

5. Press the MODE/SET Key, and the encoder type and resolution code will be displayed.

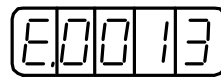

Encoder Type Encoder Resolution

Encoder Type

Code	Type
00	Incremental encoder
01	Absolute encoder

Encoder Resolution

Code	Resolution
13	13 bits
16	16 bits
17	17 bits
20	Reserved

6. Press the MODE/SET Key to display the Servopack's modification index (Modification No.)

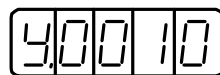

This example shows modification index "Y10".
(Indicated in decimal).

7. Press the DATA/SHIFT Key to return to the auxiliary function mode display. Pressing the DATA/SHIFT Key after the above display 3. to 5. will also return to the auxiliary function mode display.

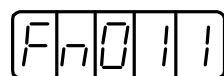

This completes the motor type checking procedure.

7.2.7 Checking the Software Version

Set Fn012 to select the software-version check mode.
This mode is used for the motor maintenance.

Follow the procedure below to check the software version.

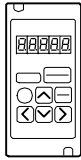

Using the Hand-held Operator

1. Select the user constant Fn012.
2. Press the DATA/ENTER Key, and the Servopack software version will be displayed.

Software Version Display

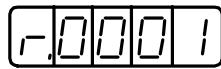

Software
Version

3. Press the DSPL/SET Key, and the software version of the encoder mounted on the motor will be displayed.

Software Version Display



Software Version

4. Press the DATA/ENTER Key to return to the user constant code display.

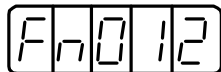

This completes the checking software version procedure.



Using the Panel Operator

1. Select the user constant Fn012.
2. Press the DATA/SHIFT Key for a minimum of one second to display the Servopack software version.
3. Press the MODE/SET Key to display the encoder software version.
4. Press the DATA/SHIFT Key for a minimum of one second to return to the user constant code display.

7.2.8 Origin Search Mode

⚠ CAUTION

- Forward run prohibited (P-OT) and reverse run prohibited (N-OT) signals are not effective during origin search mode operations using user constant Fn003.

The origin search mode is designed to position the origin pulse position of the encoder and to clamp at the position. This mode is used when the motor shaft needs to be aligned to the machine. Execute the origin search without connecting the couplings.

The speed for executing the origin search is 60 r/min.

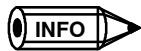
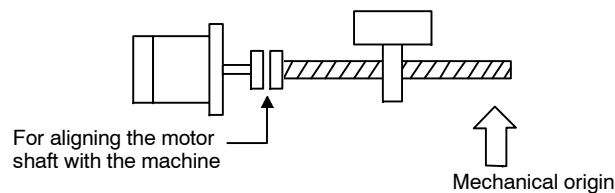

The following conditions must be met to perform the origin search operation.

- If the Servo-ON input signal (/S-ON) is ON, turn it OFF.
- Release the Servo-ON signal mask if the user constant Pn 50A.1 is set to 7, and the Servo has been set to always be ON.

Follow the procedure below to execute the origin search.

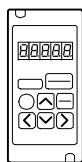

Using the Hand-held Digital Operator

1. Press the DSPL/SET Key to select the auxiliary function mode.

Fn000

2. Select the user constant Fn003.
Press the Left or Right Cursor Key to select the digit.
Press the Up or Down Cursor Key to change the value.

Fn003

3. Press the DATA/ENTER Key, and the display will be as shown below.

- . 0 5 r

4. Press the SVON Key, and the display will be as shown below. Now it is ready for executing the origin search.

. . 0 5 r

5. Hold down the Up or Down Cursor Key to execute the origin search.

When the user constant is set to Pn000.0 = 0 (default), pressing the Up Cursor Key will rotate the motor in the forward direction. Pressing the Down Cursor Key will rotate the motor in the reverse direction. When the user constant is set to Pn000.0 = 1, the rotation of the motor is reversed.

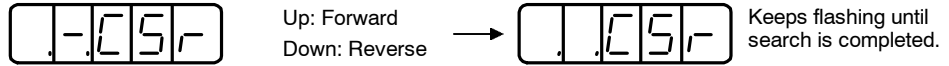

6. Press the DATA/ENTER Key to return to the auxiliary function mode display.



This completes the origin search execution.

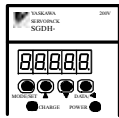

Using the Panel Operator

1. Press the MODE/SET Key to select the auxiliary function mode.

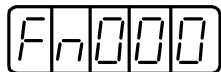

2. Press the Up or Down Cursor Key to select the user constant Fn003.

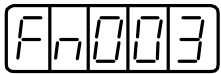

3. Press the DATA/SHIFT Key for a minimum of one second, and the display will be as shown below.

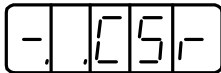

4. Press the MODE/SET Key, and the display will change as shown below. Now it is ready for executing the origin search mode.



5. Hold down the Up or Down Cursor Key to execute the origin search.

When the user constant is set to Pn000.0 = 0 (default), pressing the Up Cursor Key will rotate the motor in the forward direction. Pressing the Down Cursor Key will rotate the motor in the reverse direction. When the user constant is set to Pn000.0 = 1, the rotation of the motor is reversed.

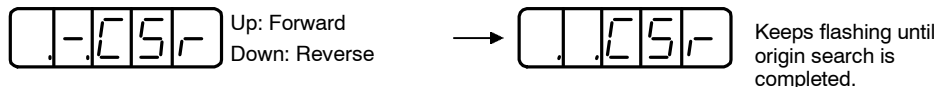

6. Press the DATA/SHIFT Key for a minimum of one second to return to the auxiliary function mode display.

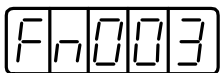

This completes the origin search execution.

7.2.9 Initializing User Constant Settings

This function is used when returning to the standard settings (factory settings) after changing user constant settings.

IMPORTANT

Initialize the user constant settings with the servo OFF.

Follow the procedure below to initialize user constant settings.

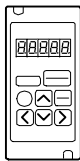

Using the Hand-held Digital Operator

1. Press the DSPL/SET Key to select the auxiliary function mode.

Fn000

2. Select the user constant Fn005.

Press the Left or Right Cursor Key to select the digit.
Press the Up or Down Cursor Key to change the value.

Fn005

3. Press the DATA/ENTER Key, and the display will be as shown below.

P. In It

4. Press the DSPL/SET Key, and the display will be as shown below. The user constants will be initialized.

P. In It

Flashing during
initialization → End

done

Flashing for
one second →

P. In It

5. Press the DATA/ENTER Key to return to the auxiliary function mode display.

Fn005

This completes the initialization of user constant settings.



Using the Panel Operator

1. Press the MODE/SET Key to select the auxiliary function mode.



2. Press the Up or Down Cursor Key to select the user constant Fn005.



3. Press the DATA/SHIFT Key for a minimum of one second, and the display will be as shown below.

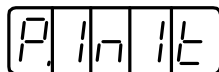

4. Press the MODE/SET Key, and the display will be as shown below. The user constants will be initialized.

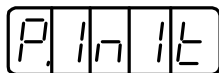

Flashing during initialization → End

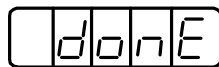

Flashing for one second →

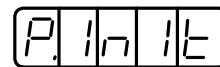

5. Press the DATA/SHIFT Key for a minimum of one second to return to the auxiliary function mode display.

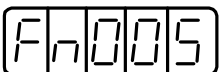

This completes the initialization of user constant settings.



User constants will not be initialized by pressing the DSPL/SET or MODE/SET Key with the servo ON. Turn the power OFF and then back ON after initialization.

7.2.10 Manual Zero Adjustment and Gain Adjustment of Analog Monitor Output

Motor speed, torque reference, and position error can be monitored through the analog monitor output. Refer to *Section 6.5 Analog Monitor*.

Use the manual zero adjustment function to compensate for the output voltage drift or the zero point drift caused by noise entering the monitor system. The gain adjustment function can be changed to match the sensitivity of the measuring system.

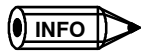
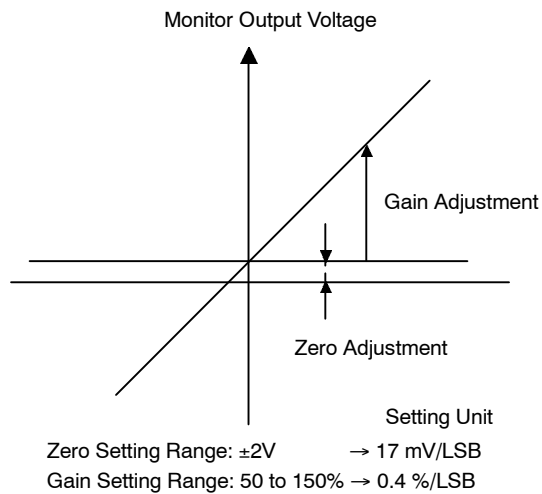

The output voltage of the analog monitor is ± 8 V. The output voltage will be reversed if ± 8 V is exceeded.

Manual Zero Adjustment of Analog Monitor Output

Follow the procedure below to execute the manual zero adjustment of analog monitor output.

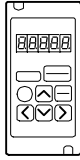

Using the Hand-held Digital Operator

1. Press the DSPL/SET Key to select the auxiliary function mode.

F_n000

2. Select the user constant F_n00C.
Press the Left or Right Cursor Key to select the digit.
Press the Up or Down Cursor Key to change the value.

F_n00C

3. Press the DATA/ENTER Key, and the display will be as shown below.

CH1_0

4. Press the DSPL/SET Key, and the monitor output for the two channels will be displayed alternately as shown below.



5. Press the Left or Right Cursor Key to display the analog monitor output data. Pressing the Left or Right Cursor Key again will return to the display shown in the above step LEERER MERKER or LEERER MERKER

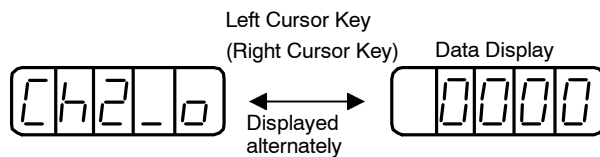

6. Press the Up or Down Cursor Key to perform zero adjustment of the analog monitor output.



7. When zero adjustment has been completed for the two channels, press the DATA/ENTER Key to return to the auxiliary function mode display.

F_n00C

This completes the manual zero adjustment of the analog monitor output.



Using the Panel Operator

1. Press the MODE/SET Key to select the auxiliary function mode.

Fn000

2. Press the Up or Down Cursor Key to select the user constant Fn00C.

Fn00C

3. Press the DATA/SHIFT Key for a minimum of one second, and the display will be as shown below

Ch1_o

4. Press the MODE/SET Key, and the monitor output for the two channels will be displayed alternately as shown below.

Ch1_o \longleftrightarrow Ch2_o
 MODE/SET Key
 Displayed Alternately

5. Press the DATA/SHIFT Key for less than one second, and the analog monitor gain constant will be displayed. Pressing the DATA/SHIFT Key again for less than one second will return to the display shown in the above step 3. or 4.

Ch2_o \longleftrightarrow 0000
 DATA/SHIFT Key
 Displayed Alternately
 Data Display

6. Press the Up or Down Cursor Key to perform zero adjustment of the analog monitor output.

0000 \longrightarrow -0001
 Data Setting Change

7. When zero adjustment has been completed for the two channels, press the DATA/SHIFT Key for a minimum of one second to return to the auxiliary function mode display.

Fn00C

This completes the manual zero adjustment of the analog monitor output.

Manual Gain Adjustment of Analog Monitor Output

Follow the procedure below to execute the manual gain adjustment of analog monitor output.

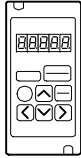

Using the Hand-held Digital Operator

1. Press the DSPL/SET Key to select the auxiliary function mode.

F_n000

2. Select the user constant F_n00D.
Press the Left or Right Cursor Key to select the digit.
Press the Up or Down Cursor Key to change the value.

F_n00D

3. Press the DATA/ENTER Key, and the display will be as shown below.

CH1_G

4. Press the DSPL/SET Key, and the monitor output for the two channels will be displayed alternately as shown below.

CH1_G ↔ CH2_G
DSPL/SET Key
Displayed Alternately

5. Press the Left or Right Cursor Key to display the analog monitor gain constant. Pressing the Left or Right Cursor Key again will return to the display shown in the above step 3. or 4.

CH2_G ↔ 0000
Left Cursor Key (Right Cursor Key)
Data Display
Displayed Alternately

6. Press the Up or Down Cursor Key to adjust the gain for the analog monitor output.

0000 → 0001
Data Setting Change

7. When the gain adjustment has been completed for the two channels, press the DATA/ENTER Key to return to the auxiliary function mode display.

F_n00D

This completes the manual gain adjustment of the analog monitor output.



Using the Panel Operator

1. Press the MODE/SET Key to select the auxiliary function mode.

Fn000

2. Press the Up or Down Cursor Key to select the user constant Fn00D.

Fn00D

3. Press the DATA/SHIFT Key for a minimum of one second, and the display will be as shown below.

CH1_0

4. Press the MODE/SET Key, and the monitor output for the two channels will be displayed alternately as shown below.

CH1_0 \longleftrightarrow CH2_0
 MODE/SET Key
 Displayed Alternately

5. Press the DATA/SHIFT Key for less than one second. The gain constant for the analog monitor will be displayed. Pressing the DATA/SHIFT Key again for less than one second will return to the display shown in the above step 3. or 4.

CH2_0 \longleftrightarrow 0000
 DATA/SHIFT Key
 Displayed Alternately
 Data Display

6. Press the Up or Down Cursor Key to adjust the gain for the analog monitor output.

0000 \longrightarrow 0001
 Data Setting Change

7. When the gain adjustment has been completed for the two channels, press the DATA/SHIFT Key for a minimum of one second to return to the auxiliary function mode display.

Fn00D

This completes the manual gain adjustment of the analog monitor output.

7.2.11 Adjusting the Motor Current Detection Offset

Motor current detection offset adjustment is performed at Yaskawa before shipping. Basically, the user need not perform this adjustment. Perform this adjustment only if highly accurate adjustment is required for reducing torque ripple caused by current offset.

The following sections describe automatic and manual adjustment of the current detection offset.

IMPORTANT

If this function, particularly manual adjustment, is executed carelessly, it may worsen the characteristics.

■ Automatic Adjustment of the Motor Current Detection Offset

Follow the procedure below to perform automatic adjustment of the current detection offset.



Automatic adjustment is possible only with power supplied to the main circuits and with the servo OFF.

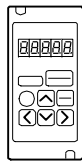

Using the Hand-held Digital Operator

1. Press the DSPL/SET Key to select the auxiliary function mode.

`Fn000`

2. Select the user constant Fn00E.
Press the Left or Right Cursor Key to select the digit.
Press the Left or Right Cursor Key to change the value.

`Fn00E`

3. Press the DATA/ENTER Key, and the display will be as shown below.

`Cur_o`

4. Press the DSPL/SET Key. The display will change as shown below and offset will be automatically adjusted.

`done` Flashing for one second → `Cur_o`

5. Press the DATA/ENTER Key to return to the auxiliary function mode display.

`Fn00E`

This completes the automatic adjustment of the motor current detection offset.



Using the Panel Operator

1. Press the MODE/SET Key to select the auxiliary function mode.

F_n0000

2. Press the Up or Down Cursor Key to select the user constant Fn00E.

F_n000E

3. Press the DATA/SHIFT Key for a minimum of one second, and the display will be as shown below.

C_ur_lo

4. Press the MODE/SET Key. The display will change as shown below and the offset will be automatically adjusted.

d_on_e → C_ur_lo

Flashing for one second

5. Press the DATA/SHIFT Key for a minimum of one second to return to the auxiliary function mode display.

F_n000E

This completes the automatic adjustment of the motor current detection offset.

Manually Adjusting the Motor Current Detection Offset

Follow the procedure below to manually adjust the current detection offset.

IMPORTANT

When making manual adjustments, run the motor at a speed of approximately 100 r/min, and adjust the Operator until the torque monitor ripple is minimized. (Refer to *Section 6.5 Analog Monitor*.) Adjust the U-phase and V-phase offsets alternately several times until these offsets are well balanced.

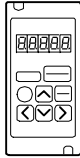

Hand-held Digital Operator

1. Press the DSPL/SET Key to select the auxiliary function mode.

F_n000

2. Select the user constant Fn00F.

Press the Left or Right Cursor Key to select the digit.
Press the Up or Down Cursor Key to change the value.

F_n00F

3. Press the DATA/ENTER Key, and the display will be as shown below.

Cu1_0

4. Press the DSPL/SET Key to switch between the U-phase (Cu1_0) and V-phase (Cu2_0) current detection offset adjustment mode.

Cu1_0 ↔ Cu2_0
DSPL/SET Key
Displayed Alternately

5. Press the Left or Right Cursor Key to display the current detection data. Pressing the Left or Right Cursor Key again will return to the display shown in the above step 3. or 4.

Cu2_0 ↔ 0000
Left Cursor Key (Right Cursor Key)
Data Display
Displayed Alternately

6. Press the Up or Down Cursor Key to adjust the offset. Carefully adjust the offset while monitoring the torque reference monitor signal.

0000 → -0001
Data Setting Change

7. When the current offset adjustment has been completed for the U-phase (Cu1_0) and V-phase (Cu2_0), press the DATA/ENTER Key to return to the auxiliary function mode display.

F_n00F

This completes the manual adjustment of the motor current detection offset.



Using the Panel Operator

1. Press the MODE/SET Key to select the auxiliary function mode.

Fn000

2. Press the Up or Down Cursor Key to select the user constant Fn00F.

Fn00F

3. Press the DATA/SHIFT Key for a minimum of one second, and the display will be as shown below.

Cu1_0

4. Press the MODE/SET Key to switch between U-phase (Cu1_0) and V-phase (Cu2_0) current detection offset adjustment mode.

Cu1_0 $\xleftrightarrow[\text{Displayed Alternately}]{\text{MODE/SET Key}}$ Cu2_0

5. Press the DATA/SHIFT Key for less than one second to display the current detection data. Press the DATA/SHIFT Key again for less than one second, and the display will return to one shown in the above step 3. or 4.

Cu2_0 $\xleftrightarrow[\text{Displayed Alternately}]{\text{DATA/SHIFT Key}}$ Data Display 0000

6. Press the Up or Down Cursor Key to adjust the offset. Carefully adjust the offset while monitoring the torque reference monitor signal.

0000 $\xrightarrow{\text{Data Setting Change}}$ -0001

7. When the current offset adjustment has been completed for the U-phase (Cu1_0) and V-phase (Cu2_0), press the DATA/SHIFT Key to return to the auxiliary function mode display.

Fn00F

This completes the manual adjustment of the motor current detection offset.

7.2.12 Password Setting (Write Prohibited Setting)

The password setting is used for preventing careless changes of the user constant. User constants Pn□□□ and some of Fn□□□ become write prohibited by setting the password.

Password setting values are as follows:

- “0000”: Write enabled (Releases write prohibited mode.)
- “0001”: Write prohibited (User constants become write enabled from the next power ON.)

Follow the procedure below to set the password.

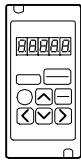

Using the Hand-held Digital Operator

1. Press the DSPL/SET Key to select the auxiliary function mode.

F_n0000

2. Select the user constant Fn010.
Press the Left or Right Cursor Key to select the digit.
Press the Up or Down Cursor Key to change the value.

F_n010

3. Press the DATA/ENTER Key, and the display will be as shown below.

P.0000

4. Input the password (0001) and press the DSPL/SET Key. The display will change as shown below and the password will be registered.

done → P.00001
Flashing for one second

5. Press the DATA/ENTER Key to return to the auxiliary function mode display.

F_n010

This completes the password setting. The newly set password will become valid from the next time the power is turned ON.



Using the Panel Operator

1. Press the MODE/SET Key to select the auxiliary function mode.

Fn0000

2. Press the Up or Down Cursor Key to select the user constant Fn010.

Fn010

3. Press the DATA/SHIFT Key for a minimum of one second, and the display will be as shown below.

P.00000

4. Input the password (0001) and press the MODE/SET Key. The display will change to one shown below and the password will be registered.

done → P.00001
Flashing for one second

5. Press the DATA/SHIFT Key for a minimum of one second to return to the auxiliary function mode display.

Fn010

This completes the procedure for setting the password. The newly set password will become valid from the next power ON.

7.2.13 Clearing Option Unit Detection Results

The alarm A.E7 (option unit detection fail) occurs when turning ON the power for the first time when the SGDh is used without option unit after the SGDh has been used with option unit.

The following operation does not permanently reset the alarm A.E7. Restarting again after performing the following operation will clear and reset the alarm A.E7. Then, the operation of SGDh without option unit is enabled.

IMPORTANT

Because the user constant is set for the SGDh with an option unit, change the setting or initialize the user constant value (Fn005 of auxiliary function mode) as required.

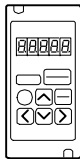

Using the Hand-held Digital Operator

1. Press the DSPL/SET Key to select the auxiliary function mode.

Fn000

2. Select the user constant Fn014.
Press the Left or Right Cursor Key to select the digit.
Press the Up or Down Cursor Key to change the value.

Fn014

3. Press the DATA/ENTER Key, and the display will be as shown below.

o.ln.lt

4. Press the DSPL/SET Key, and the display will be as shown below. The option unit detection results will be cleared.

o.ln.lt

Flashing during initialization → End

done

Flashing for one second →

o.ln.lt

5. Press the DATA/ENTER Key to return to the auxiliary function mode display.

Fn014

This completes the clear of the option unit detection results.



Using the Panel Operator

1. Press the MODE/SET Key to select the auxiliary function mode.

Fn000

2. Press the Up or Down Cursor Key to select the user constant Fn014.

Fn014

3. Press the DATA/SHIFT Key for a minimum of one second, and the display will be as shown below.

o.inIt

4. Press the MODE/SET Key, and the display will be as shown below. The option unit detection results will be cleared.

o.inIt

Flashing during
initialization → End

done

Flashing for
one second →

o.inIt

5. Press the DATA/SHIFT Key to return to the auxiliary function mode display.

Fn014

This completes the clear of the option unit detection results.



8

Ratings and Characteristics

This chapter provides the ratings, torque-speed characteristics diagrams, and dimensional drawings of the Σ -II Series Servo Drives.

8.1 Servomotors	8 - 2
8.1.1 Ratings, Specifications, and Dimensional Drawings	8 - 2
8.2 Servopacks	8 - 28
8.2.1 Combined Specifications	8 - 28
8.2.2 Ratings and Specifications	8 - 33
8.2.3 Dimensional Drawings	8 - 40

8.1 Servomotors

This section describes ratings, specifications, and dimensional drawings of the Servomotors. Refer to this section for selecting an appropriate Servo Drivers.

8.1.1 Ratings, Specifications, and Dimensional Drawings

The following sections provide the ratings specifications, and dimensional drawings of the Servomotors by model.

■ SGMAH Servomotors

Ratings and Specifications for Standard Servomotors

- Time Rating: Continuous
- Vibration Class: 15 μm or below
- Insulation Resistance: 500 VDC, 10 M Ω min.
- Ambient Temperature: 0 to 40°C
- Excitation: Permanent magnet
- Mounting: Flange method
- Thermal Class: B
- Withstand Voltage: 1500 VAC for one minute
- Enclosure: Totally enclosed, self-cooled, IP55 (except for through sections of the shaft)
- Ambient Humidity: 20% to 80% (with no condensation)
- Drive Method: Direct drive

Table 8.1 SGMAH Standard Servomotor Ratings and Specifications

Voltage		200 V						100 V			
Servomotor Model SGMAH-		A3A	A5A	01A	02A	04A	08A	A3B	A5B	01B	02B
Rated Output *1	kW	0.03	0.05	0.1	0.2	0.4	0.75	0.03	0.05	0.1	0.2
Rated Torque *1,*2	N·m	0.0955	0.159	0.318	0.637	1.27	2.39	0.0955	0.159	0.318	0.637
	oz·in	13.52	22.5	45.1	90.2	180	338	13.52	22.5	45.1	90.2
Instantaneous Peak Torque *1	N·m	0.286	0.477	0.955	1.91	3.82	7.16	0.286	0.477	0.955	1.91
	oz·in	40.6	67.6	135.2	270	541	1010	40.6	67.6	135.2	270
Rated Current *1	A (rms)	0.44	0.64	0.91	2.1	2.8	4.4	0.66	0.95	2.4	3.0
Instantaneous Max. Current *1	A (rms)	1.3	2.0	2.8	6.5	8.5	13.4	2.0	2.9	7.2	9.0
Rated Speed *1	r/min	3000									
Max. Speed *1	r/min	5000									
Torque Constant	N·m/A (rms)	0.238	0.268	0.378	0.327	0.498	0.590	0.157	0.182	0.146	0.234
	oz·in/A (rms)	33.7	38.0	53.6	46.2	70.6	83.6	22.2	25.8	20.7	33.2
Moment of Inertia	$\times 10^{-4}$ kg·m ²	0.0166	0.0220	0.0364	0.106	0.173	0.672	0.0166	0.0220	0.0364	0.106
	$\times 10^{-3}$ oz·in·s ²	0.235	0.312	0.515	1.501	2.45	9.52	0.235	0.312	0.515	1.501
Rated Power Rate *1	kW/s	5.49	11.5	27.8	38.2	93.7	84.8	5.49	11.5	27.8	38.2

Voltage		200 V						100 V			
Servomotor Model SGMAH-		A3A	A5A	01A	02A	04A	08A	A3B	A5B	01B	02B
Rated Angular Acceleration *1	rad/s ²	57500	72300	87400	60100	73600	35500	57500	72300	87400	60100
Inertia Time Constant	ms	1.4	0.88	0.53	0.39	0.25	0.26	1.4	0.85	0.61	0.41
Inductive Time Constant	ms	1.0	1.1	1.2	4.6	5.4	8.7	1.0	1.1	1.1	4.4

* 1. These items and torque-motor speed characteristics quoted in combination with an SGDH Servopack are at an armature winding temperature of 100°C. Other values quoted at 20°C. All values are typical.

* 2. Rated torques are continuous allowable torque values at 40°C with a 250 × 250 × 6 (mm) (10 × 10 × 0.25 (in.)) heat sink attached.

SGMAH Servomotor Torque-Motor Speed Characteristics

The torque-motor speed characteristics are shown below for the SGMAH Servomotors.

● **200-V Servomotors**

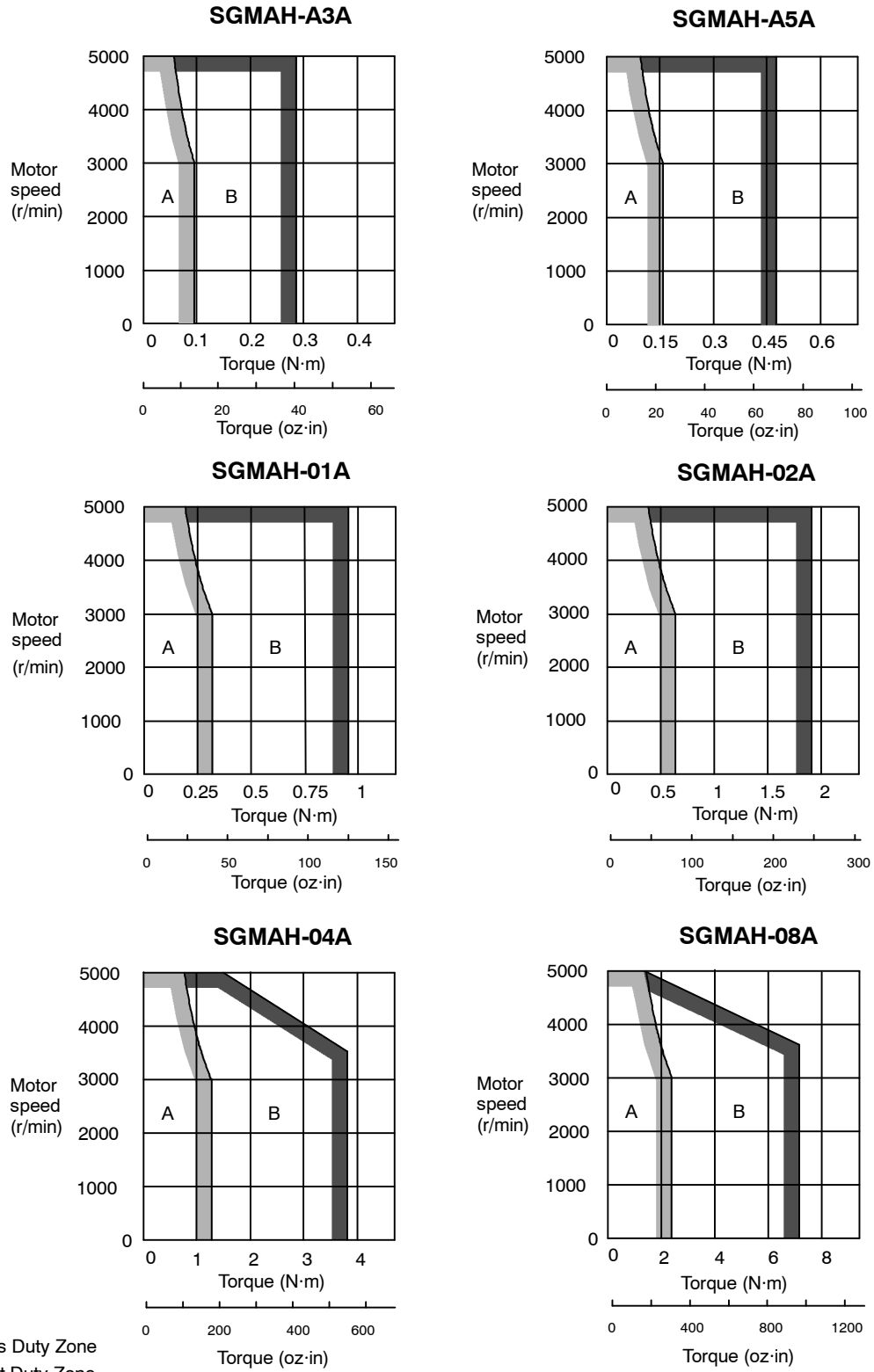

8

● 100-V Servomotors

SGMAH-A3B

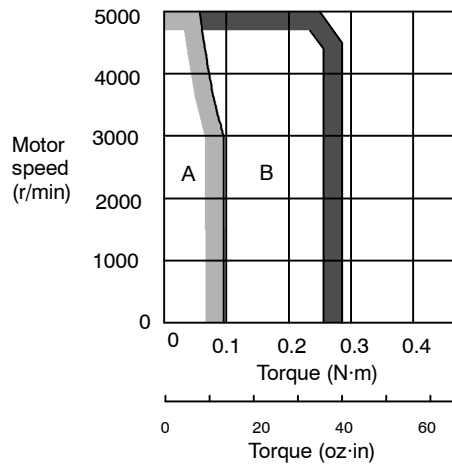

SGMAH-A5B

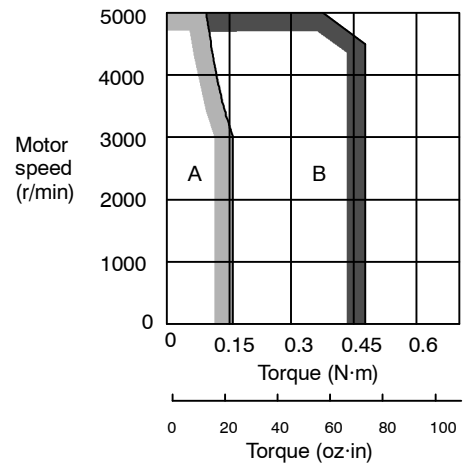

SGMAH-01B

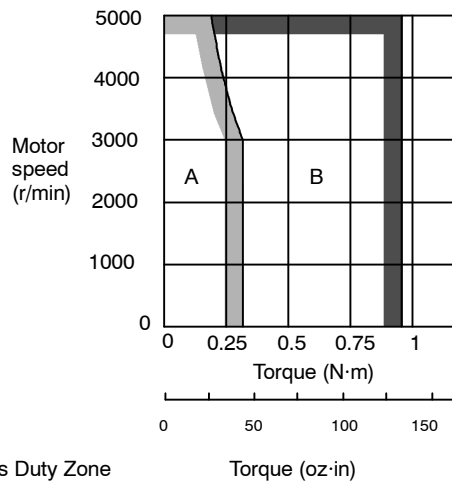

SGMAH-02B

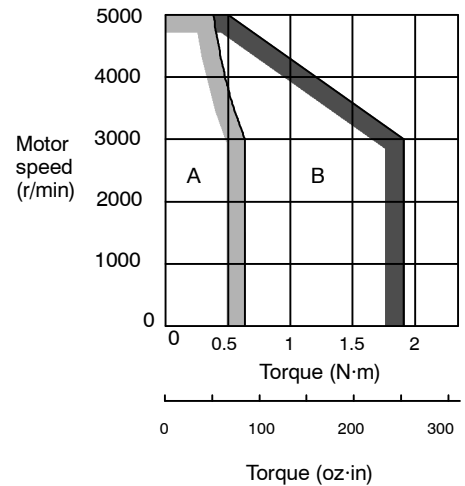

A: Continuous Duty Zone
 B: Intermittent Duty Zone

Dimensional Drawings

Dimensional drawings of the SGMAH Servomotors are shown below.

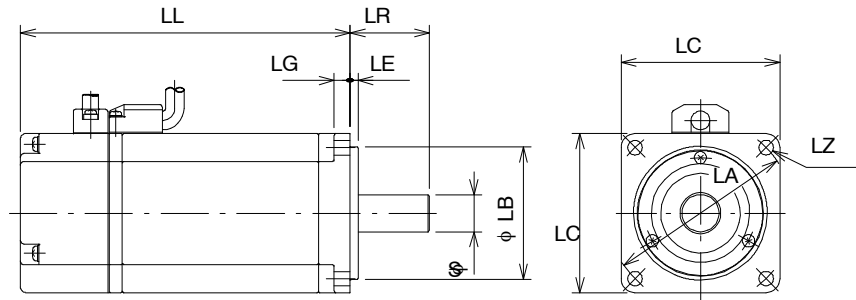

Unit: mm (in)

Model	LL	LC	LA	LZ	LG	LB	LE	S	LR	Mass kg (lb)
SGMAH-A3A (B)	69.5 (2.74)	40 (1.57)	46 (1.81)	4.3 (0.17)	5 (0.20)	$30 \begin{matrix} 0 \\ -0.021 \end{matrix} \begin{matrix} 1.19 \\ -0.0008 \end{matrix}$	2.5 (0.098)	$6 \begin{matrix} 0 \\ -0.008 \end{matrix} \begin{matrix} 0.24 \\ -0.0003 \end{matrix}$	25 (0.98)	0.3 (0.661)
SGMAH-A5A (B)	77.0 (3.03)									0.4 (0.882)
SGMAH-01A (B)	94.5 (3.72)									0.5 (1.10)
SGMAH-02A (B)	96.5 (3.80)	60 (2.36)	70 (2.76)	5.5 (0.22)	6 (0.24)	$50 \begin{matrix} 0 \\ -0.025 \end{matrix} \begin{matrix} 1.98 \\ -0.0010 \end{matrix}$	3 (0.12)	$14 \begin{matrix} 0 \\ -0.011 \end{matrix} \begin{matrix} 0.56 \\ -0.0004 \end{matrix}$	30 (1.18)	1.1 (2.43)
SGMAH-04A	124.5 (4.90)									1.7 (3.75)
SGMAH-08A	145 (5.71)									3.4 (7.50)
		80 (3.15)	90 (3.54)	7 (0.28)	8 (0.31)	$70 \begin{matrix} 0 \\ -0.030 \end{matrix} \begin{matrix} 2.78 \\ -0.0012 \end{matrix}$		$16 \begin{matrix} 0 \\ -0.011 \end{matrix} \begin{matrix} 0.64 \\ -0.0004 \end{matrix}$	40 (1.57)	

■ SGMPH Servomotors

Ratings and Specifications for Standard Servomotors

- Time Rating: Continuous
- Vibration Class: 15 μ m or below
- Insulation Resistance: 500 VDC, 10 M Ω min.
- Ambient Temperature: 0 to 40°C
- Excitation: Permanent magnet
- Mounting: Flange method
- Thermal Class: B
- Withstand Voltage: 1500 VAC for one minute
- Enclosure: Totally enclosed, self-cooled, IP55 (except for through sections of the shaft)
- Ambient Humidity: 20% to 80% (with no condensation)
- Drive Method: Direct drive

Table 8.2 SGMPH Standard Servomotor Ratings and Specifications

Voltage		200 V					100 V	
Servomotor Model		01A	02A	04A	08A	15A	01B	02B
SGMPH-								
Rated Output *1	kW	0.1	0.2	0.4	0.75	1.5	0.1	0.2
Rated Torque *1,*2	N·m	0.318	0.637	1.27	2.39	4.77	0.318	0.637
	oz·in	45.1	90.2	180	338	676	45.1	90.2
Instantaneous Peak Torque *1	N·m	0.955	1.91	3.82	7.16	14.3	0.955	1.91
	oz·in	135	270	541	1010	2030	135.2	270
Rated Current *1	A (rms)	0.89	2.0	2.6	4.1	7.5	2.2	2.7
Instantaneous Max. Current *1	A (rms)	2.8	6.0	8.0	13.9	23.0	7.1	8.4
Rated Speed *1	r/min	3000						
Max. Speed *1	r/min	5000						
Torque Constant	N·m/A (rms)	0.392	0.349	0.535	0.641	0.687	0.160	0.258
	oz·in /A (rms)	55.6	49.4	75.8	91.0	97.4	22.8	36.5
Moment of Inertia	$\times 10^{-4}$ kg·m ²	0.0491	0.193	0.331	2.10	4.02	0.0491	0.193
	$\times 10^{-3}$ oz·in·s ²	0.695	2.73	4.69	29.7	56.9	0.695	2.73
Rated Power Rate *1	kW/s	20.6	21.0	49.0	27.1	56.7	20.6	21.0
Rated Angular Acceleration *1	rad/s ²	64800	33000	38500	11400	11900	64800	33000
Inertia Time Constant	ms	0.53	0.54	0.36	0.66	0.46	0.56	0.64
Inductive Time Constant	ms	3.7	7.4	8.6	18	22	3.6	6.3

* 1. These items and torque-motor speed characteristics quoted in combination with an SGD Servopack are at an armature winding temperature of 100°C. Other values quoted at 20°C. All values typical.

* 2. Rated torques are continuous allowable torque values at 40°C with a heat sink attached.

Heat sink dimensions

250 × 250 × 6 (mm) (10 × 10 × 0.25 (in)): 0.1 kW to 0.4 kW

300 × 300 × 12 (mm) (12 × 12 × 0.5 (in)): 0.75 kW to 1.5 kW

SGMPH Servomotor Torque-Motor Speed Characteristics

The torque-motor speed characteristics are shown below for the SGMPH Servomotors.

● **200-V Servomotors**

SGMPH-01A

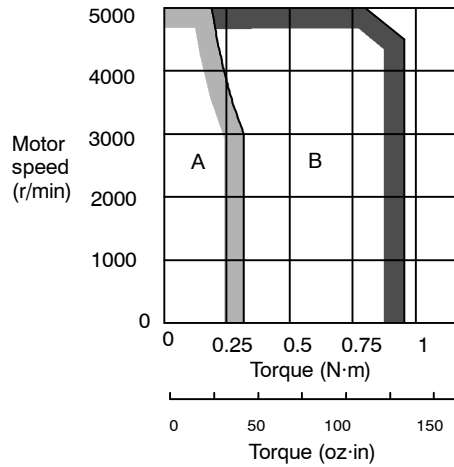

SGMPH-02A

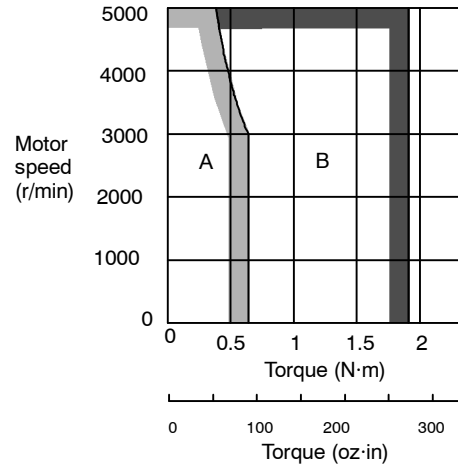

SGMPH-04A

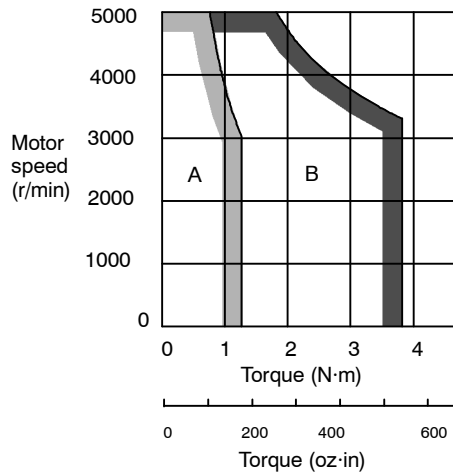

SGMPH-08A

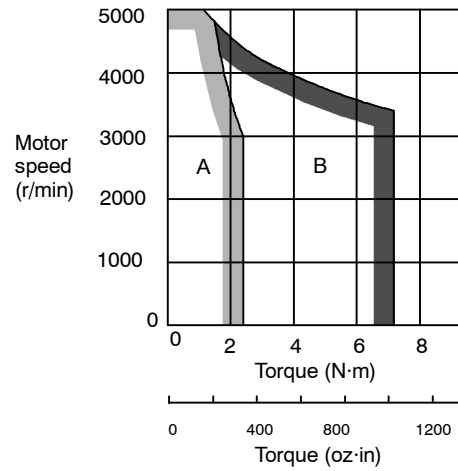

SGMPH-15A

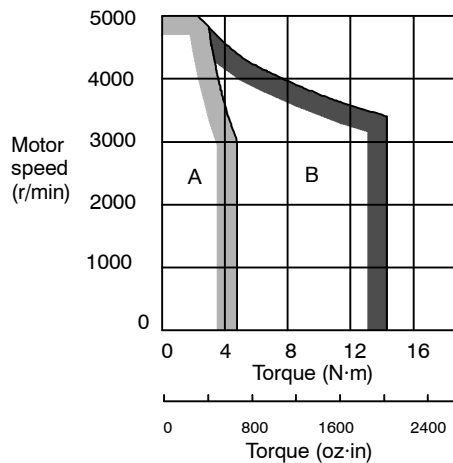

A: Continuous Duty Zone
B: Intermittent Duty Zone

• 100-V Servomotors

SGMPH-01B

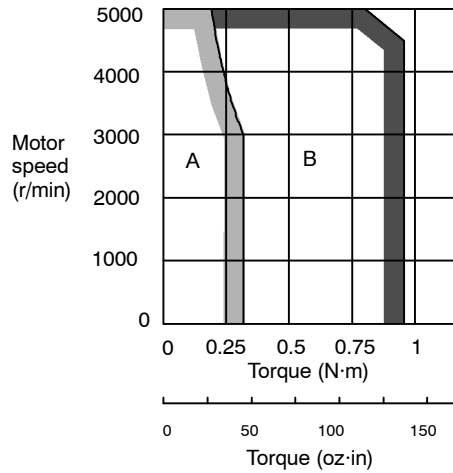

SGMPH-02B

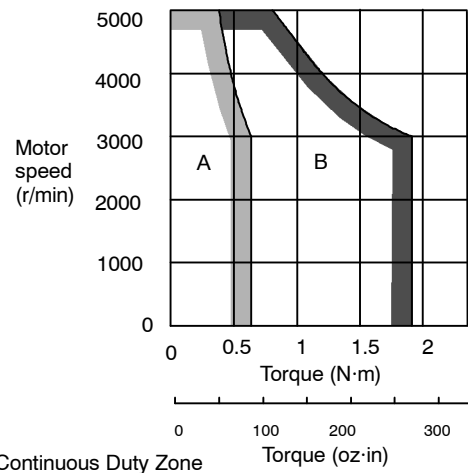

A: Continuous Duty Zone
B: Intermittent Duty Zone

Dimensional Drawings

Dimensional drawings of the SGMPH Servomotors are shown below.

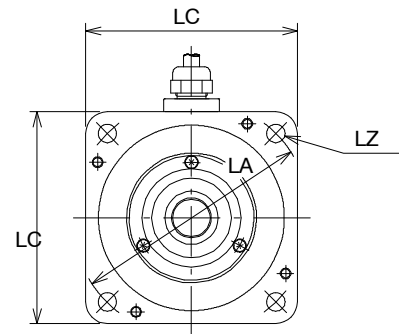
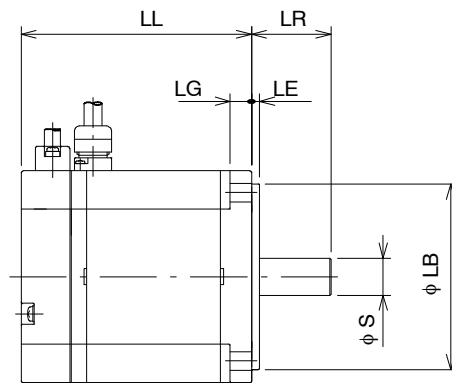

Unit: mm (in)

Model	LL	LC	LA	LZ	LG	LB	LE	S	LR	Mass kg (lb)
SGMPH-01A (B)	62 (2.44)	60 (2.36)	70 (2.76)	5.5 (0.22)	6 (0.24)	$50 \begin{matrix} 0 \\ -0.025 \end{matrix} \begin{matrix} 1.98 \\ -0.0010 \end{matrix}$	3 (0.12)	$8 \begin{matrix} 0 \\ -0.009 \end{matrix} \begin{matrix} 0.32 \\ -0.0004 \end{matrix}$	25 (0.98)	0.7 (1.54)
SGMPH-02A (B)	67 (2.64)	80 (3.15)	90 (3.54)	7 (0.28)	8 (0.31)	$70 \begin{matrix} 0 \\ -0.030 \end{matrix} \begin{matrix} 2.78 \\ -0.0012 \end{matrix}$		$14 \begin{matrix} 0 \\ -0.011 \end{matrix} \begin{matrix} 0.56 \\ -0.0004 \end{matrix}$	30 (1.18)	1.4 (3.09)
SGMPH-04A	87 (3.43)									2.1 (4.63)
SGMPH-08A	86.5 (3.41)	120 (4.72)	145 (5.71)	10 (0.39)	10 (0.39)	$110 \begin{matrix} 0 \\ -0.035 \end{matrix} \begin{matrix} 4.37 \\ -0.0014 \end{matrix}$	3.5 (0.14)	$16 \begin{matrix} 0 \\ -0.011 \end{matrix} \begin{matrix} 0.64 \\ -0.0004 \end{matrix}$	40 (1.57)	4.2 (9.26)
SGMPH-15A	114.5 (4.51)									6.6 (14.6)

■ SGMGH Servomotors for 1500 r/min

Rating and Specifications for Standard Servomotors

- Time Rating: Continuous
- Vibration Class: 15 μ m or below
- Insulation Resistance: 500 VDC, 10 M Ω min.
- Ambient Temperature: 0 to 40°C
- Excitation: Permanent magnet
- Mounting: Flange method
- Thermal Class: F
- Withstand Voltage:
 - 1500 VAC for one minute (200 V specification)
 - 1800 VAC for one minute (400 V specification)
- Enclosure: Totally enclosed, IP67 self cooled (except for through sections of the shaft)
- Ambient Humidity: 20% to 80% (with no condensation)
- Drive Method: Direct drive

Table 8.3 SGMGH Standard Servomotor Ratings and Specifications (200 V)

Voltage		200 V									
Servomotor Model SGMGH-		05A□ A	09A□ A	13A□ A	20A□ A	30A□ A	44A□ A	55A□ A	75A□ A	1AA□ A	1EA□ A
Rated Output *	kW	0.45	0.85	1.3	1.8	2.9	4.4	5.5	7.5	11	15
Rated Torque *	N·m	2.84	5.39	8.34	11.5	18.6	28.4	35.0	48.0	70.0	95.4
	lb·in	25	48	74	102	165	252	310	425	620	845
Instantaneous Peak Torque *	N·m	8.92	13.8	23.3	28.7	45.1	71.1	87.6	119	175	224
	lb·in	79	122	207	254	404	630	775	1050	1550	1984
Rated Current *	A (rms)	3.8	7.1	10.7	16.7	23.8	32.8	42.1	54.7	58.6	78.0
Instantaneous Max. Current *	A (rms)	11	17	28	42	56	84	110	130	140	170
Rated Speed *	r/min	1500									
Max. Speed *	r/min	3000								2000	
Torque Constant	N·m/A (rms)	0.82	0.83	0.84	0.73	0.83	0.91	0.88	0.93	1.25	1.32
	lb·in/A (rms)	7.26	7.35	7.43	6.46	7.35	8.05	7.79	8.23	11.1	11.7
Moment of Inertia	x10 ⁻⁴ kg·m ²	7.24	13.9	20.5	31.7	46.0	67.5	89.0	125	281	315
	x10 ⁻³ lb·in·s ²	6.41	12.3	18.2	28.1	40.7	59.8	78.8	111	250	355
Rated Power Rate *	kW/s	11.2	20.9	33.8	41.5	75.3	120	137	184	174	289
Rated Angular Acceleration *	rad/s ²	3930	3880	4060	3620	4050	4210	3930	3850	2490	3030
Inertia Time Constant	ms	5.0	3.1	2.8	2.1	1.9	1.3	1.3	1.1	1.2	0.98
Inductive Time Constant	ms	5.1	5.3	6.3	12.5	12.5	15.7	16.4	18.4	22.6	27.2

Table 8.4 SGMGH Standard Servomotor Ratings and Specifications (400 V)

Voltage		400 V									
Servomotor Model SGMGH-		05D□ A	09D□ A	13D□ A	20D□ A	30D□ A	44D□ A	55D□ A	75D□ A	1AD□ A	1ED□ A
Rated Output *	kW	0.45	0.85	1.3	1.8	2.9	4.4	5.5	7.5	11	15
Rated Torque *	N·m	2.84	5.39	8.34	11.5	18.6	28.4	35.0	48.0	70.0	95.4
	lb·in	25	48	74	102	165	252	310	425	620	845

Servomotor Model SGMGH-		05D□ A	09D□ A	13D□ A	20D□ A	30D□ A	44D□ A	55D□ A	75D□ A	1AD □A	1ED□ A
Instantaneous Peak Torque *	N·m	8.92	13.8	23.3	28.7	45.1	71.1	90.7	123	175	221
	lb·in	79	122	207	254	400	630	804	1091	1550	1960
Rated Current *	A (rms)	1.9	3.5	5.4	8.4	11.9	16.5	20.8	25.4	28.1	37.2
Instantaneous Max. Current *	A (rms)	5.5	8.5	14	20	28	40.5	55	65	70	85
Rated Speed *	r/min	1500									
Max. Speed *	r/min	3000								2000	
Torque Constant	N·m/A (rms)	1.64	1.65	1.68	1.46	1.66	1.82	1.74	2.0	2.56	2.64
	lb·in/A (rms)	14.5	14.6	14.9	12.9	14.7	16.1	15.4	17.7	22.7	23.4
Moment of Inertia	x10 ⁻⁴ kg·m ²	7.24	13.9	20.5	31.7	46.0	67.5	89.0	125	281	315
	x10 ⁻³ lb·in·s ²	6.42	12.3	18.2	28	40.7	59.8	78.8	111	250	355
Rated Power Rate *	kW/s	11.2	20.9	33.8	41.5	75.3	120	137	184	174	289
Rated Angular Acceleration *	rad/s ²	3930	3880	4060	3620	4050	4210	3930	3850	2490	3030
Inertia Time Constant	ms	5.6	3.1	2.9	2.4	2.0	1.4	1.4	1.1	1.1	1.0
Inductive Time Constant	ms	4.5	5.3	6.1	11.1	12.3	15.2	14.4	17.6	22.9	26.2

* These items and torque-motor speed characteristics quoted in combination with an SGD7 Servopack are at an armature winding temperature of 20°C.

Note These characteristics are values with the following heat sinks attached for cooling.

400 × 400 × 20 (mm) (15.75 × 15.75 × 0.79 (in)): 05A□A to 13A□A Servomotors,
05D A to 13D A Servomotors

550 × 550 × 30 (mm) (21.65 × 21.65 × 1.18 (in)): 20A□A to 75A□A Servomotors,
20D A to 30D A Servomotors

SGMGH Servomotor Torque-Motor Speed Characteristics

The following sections provide the torque-motor speed characteristics of the SGMGH Servomotors at 1500 r/min.

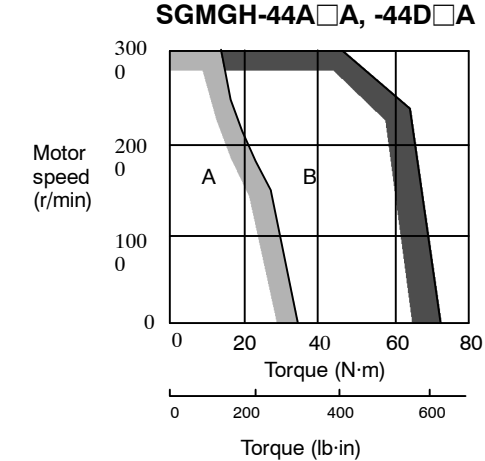
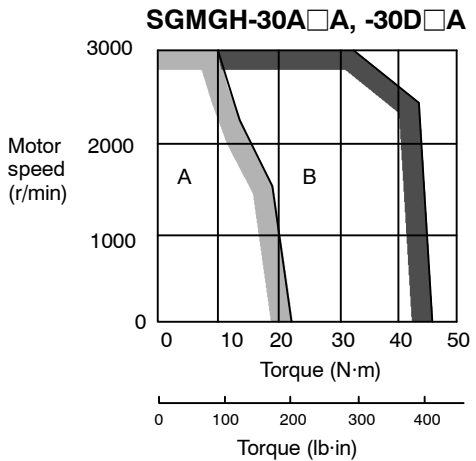
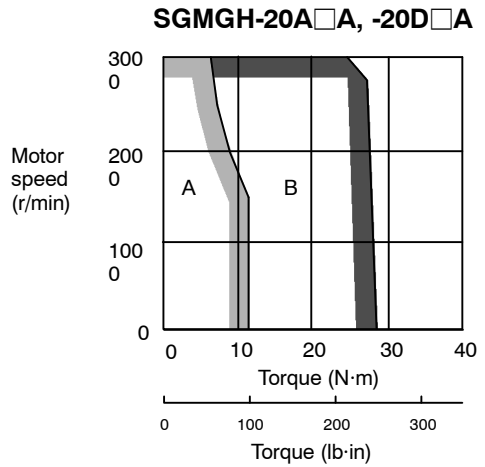
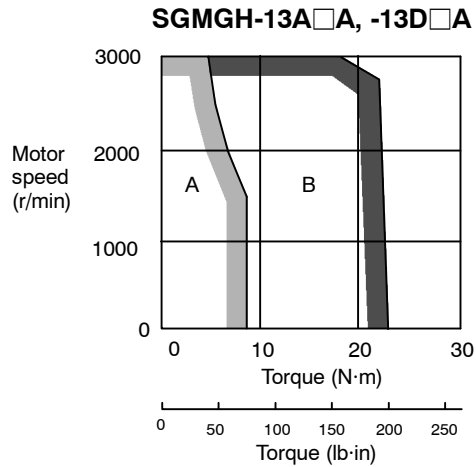
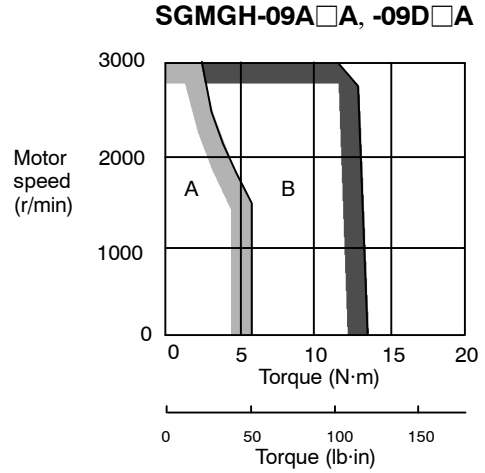
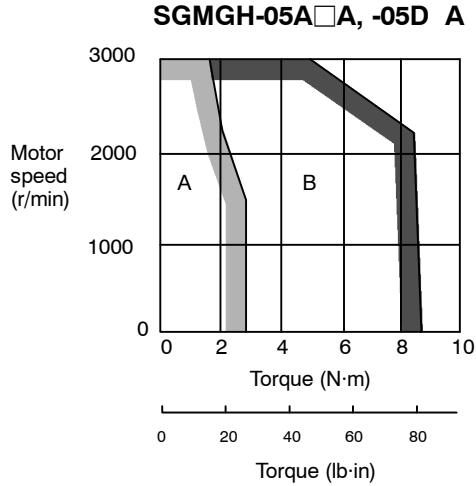

A: Continuous Duty Zone
 B: Intermittent Duty Zone

8

SGMGH-55A□A, -55D□A

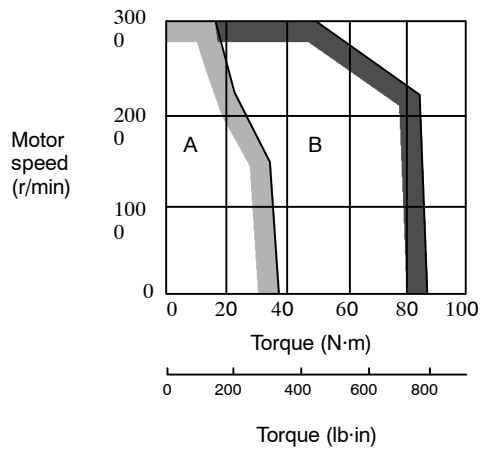

SGMGH-75A□A -75D□A

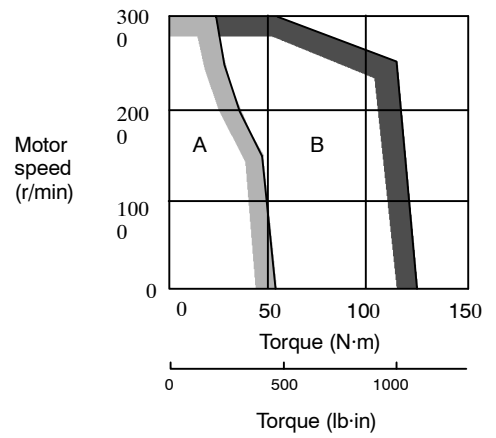

SGMGH-1AA□A, -1AD□A

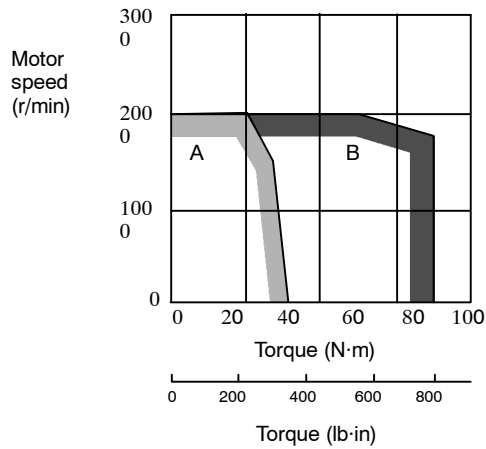

SGMGH-1EA□A, -1ED□A

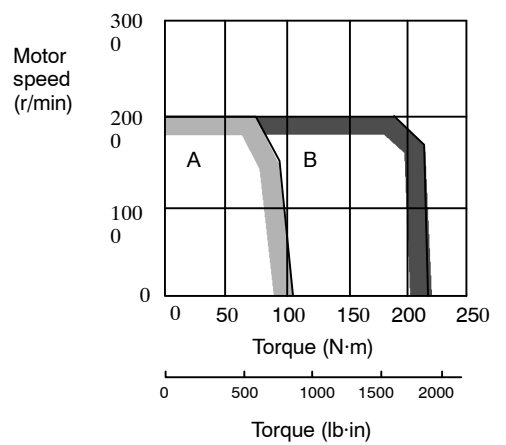

A: Continuous Duty Zone
B: Intermittent Duty Zone

Dimensional Drawings

Dimensional drawings of the SGMGH Servomotors (1500 r/min) are shown below.

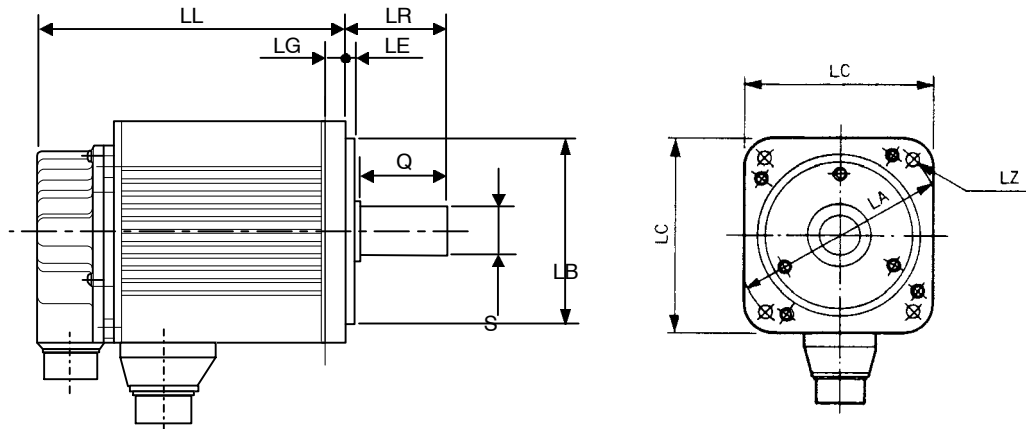

Unit: mm (in)

Model	LL	LC	LA	LZ	LG	LB	LE	Q	S	LR	Mass kg (lb)			
SGMGH-05A □A -05D □A	138 (5.43)	130 (5.12)	145 (5.71)	9 (0.35)	12 (0.47)	110 ⁰ _{-0.035} □ 433 ⁰ _{-0.0014} □	6 (0.24)	40 (1.57)	19 ⁰ _{-0.013} □ 075 ⁰ _{-0.0005} □	58 (2.28)	5.5 (12.1)			
SGMGH-09A □A -09D □A	161 (6.34)										7.6 (16.8)			
SGMGH-13A □A -13D □A	185 (7.28)										9.6 (21.2)			
SGMGH-20A □A -20D □A	166 (6.54)	180 (7.09)	200 (7.87)	13.5 (0.53)	18 (0.71)	114.3 ⁰ _{-0.025} □ 450 ⁰ _{-0.0010} □	3.2 (0.13)	76 (2.99)	35 ^{0.01} ₀ □ 138 ^{0.0004} ₀ □	79 (3.11)	14 (30.9)			
SGMGH-30A □A -30D □A	192 (7.56)										18 (39.7)			
SGMGH-44A A -44D □A	226 (8.9)										23 (50.7)			
SGMGH-55A A -55D □A	260 (10.2)										110 (4.33)	42 ⁰ _{-0.016} □ 165 ⁰ _{-0.0006} □	113 (4.45)	30 (66.1)
SGMGH-75A A -75D □A	334 (13.1)													40 (88.2)
SGMGH-1AA A -1AD □A	338 (13.3)										220 (8.66)	235 (9.25)		
SGMGH-1EA A -1ED □A	457 (18.0)	20 (0.79)	55 ^{0.030} _{0.011} □ 217 ^{0.0012} _{0.0004} □	86 (188.2)										

8

■ SGMGH Servomotors for 1000 r/min

Rating and Specifications for Standard Servomotors

- Time Rating: Continuous
- Vibration Class: 15 μm or below
- Insulation Resistance: 500 VDC, 10 M Ω min.
- Ambient Temperature: 0 to 40°C
- Excitation: Permanent magnet
- Mounting: Flange method
- Thermal Class: F
- Withstand Voltage: 1500 VAC for one minute
- Enclosure: Totally enclosed, IP67 self cooled (except for through sections of the shaft)
- Ambient Humidity: 20% to 80% (with no condensation)
- Drive Method: Direct drive

Table 8.5 SGMGH Standard Servomotor Ratings and Specifications

Servomotor Model SGMGH-		03A□B	06A□B	09A□B	12A□B	20A□B	30A□B	40A B	55A B
Rated Output *	kW	0.3	0.6	0.9	1.2	2.0	3.0	4.0	5.5
Rated Torque *	N·m	2.84	5.68	8.62	11.5	19.1	28.4	38.2	52.6
	lb·in	25	50	76	102	169	252	338	466
Instantaneous Peak Torque *	N·m	7.17	14.1	19.3	28.0	44.0	63.7	107	136.9
	lb·in	63	125	171	248	390	564	947	1212
Rated Current *	A (rms)	3.0	5.7	7.6	11.6	18.5	24.8	30	43.2
Instantaneous Max. Current *	A (rms)	7.3	13.9	16.6	28	42	56	84	110
Rated Speed *	r/min	1000							
Max. Speed *	r/min	2000							
Torque Constant	N·m/A (rms)	1.03	1.06	1.21	1.03	1.07	1.19	1.34	1.26
	lb·in/A (rms)	9.12	9.38	10.7	9.12	9.47	10.5	11.9	11.2
Moment of Inertia	$\times 10^{-4}$ kg·m ²	7.24	13.9	20.5	31.7	46.0	67.5	89.0	125
	$\times 10^{-3}$ lb·in·s ²	6.41	12.3	18.2	28.1	40.7	59.8	78.8	111
Rated Power Rate *	kW/s	11.2	23.2	36.3	41.5	79.4	120	164	221
Rated Angular Acceleration *	rad/s ²	3930	4080	4210	3620	4150	4210	4290	4200
Inertia Time Constant	ms	5.1	3.8	2.8	2.0	1.7	1.4	1.3	1.1
Inductive Time Constant	ms	5.1	4.7	5.7	13.5	13.9	15.5	14.6	16.5

* These items and torque-motor speed characteristics quoted in combination with an SGD Servopack are at an armature winding temperature of 20°C.

Note These characteristics are values with the following heat sinks attached for cooling.
 400 × 400 × 20 (mm) (15.75 × 15.75 × 0.79 (in)): 03A□B to 09A□B Servomotors
 550 × 550 × 30 (mm) (21.65 × 21.65 × 1.18 (in)): 12A□B to 55A□B Servomotors

SGMGH Servomotor Torque-Motor Speed Characteristics

The following sections provide the torque-motor speed characteristics of the SGMGH Servomotors at 1000 r/min.

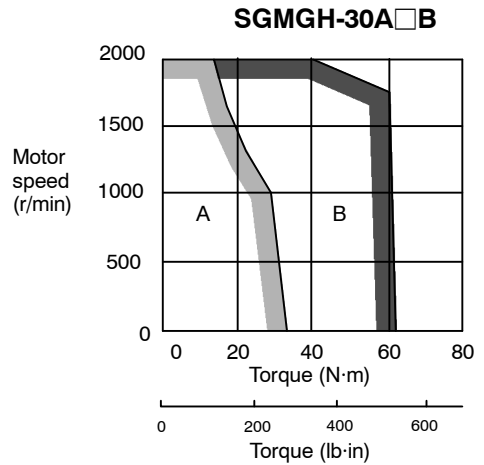
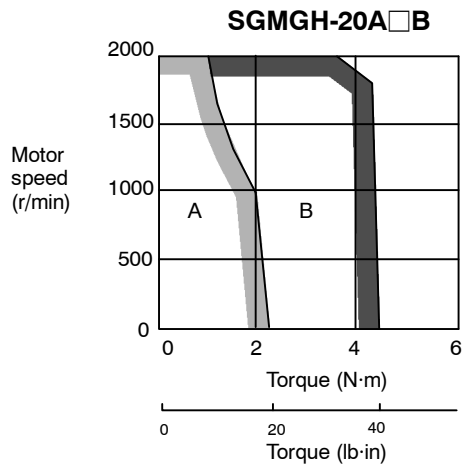
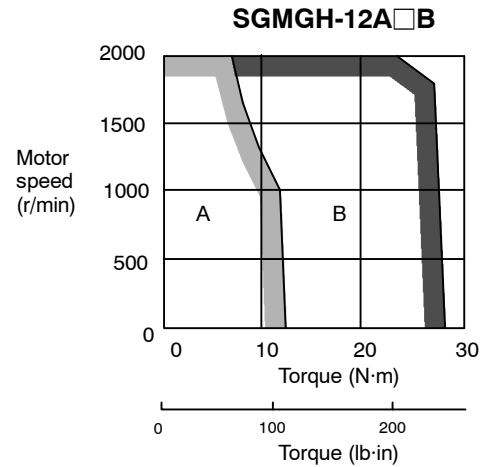
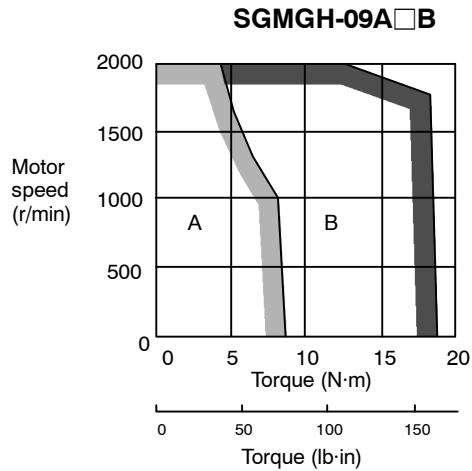
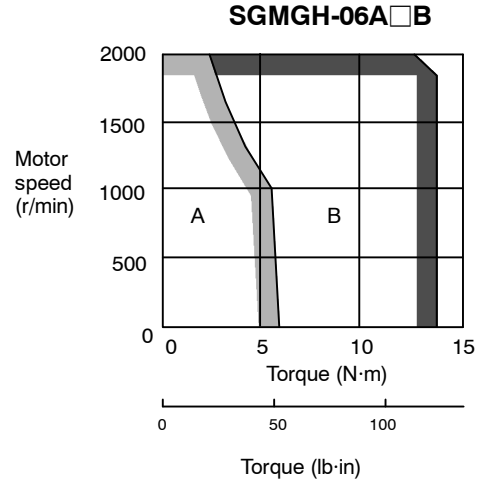
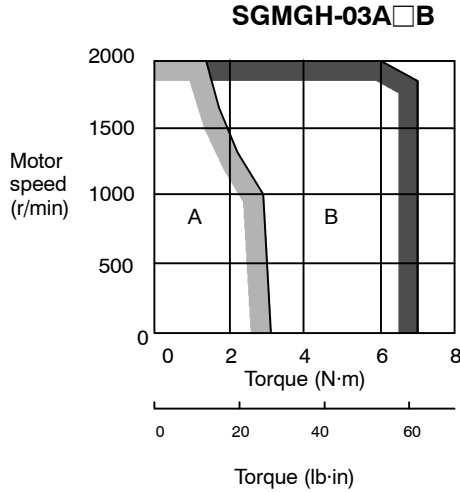

A: Continuous Duty Zone
 B: Intermittent Duty Zone

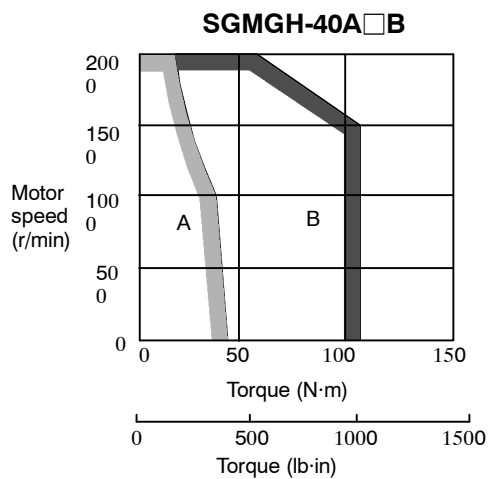

A: Continuous Duty Zone

B: Intermittent Duty Zone

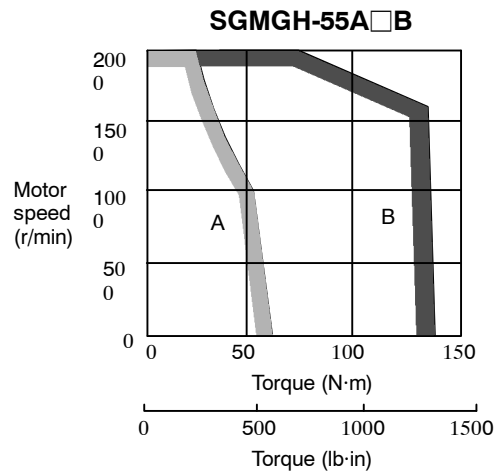

Dimensional Drawings

Dimensional drawings of the SGMGH Servomotors (1000 r/min) are shown below.

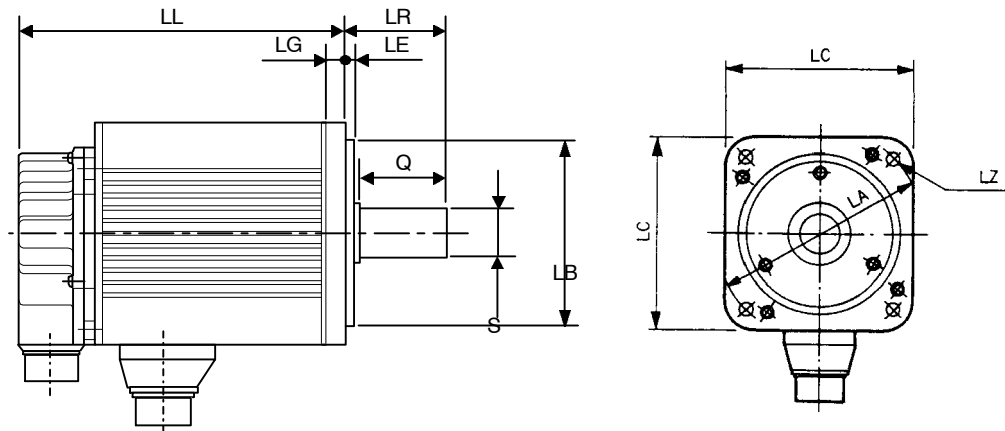

Unit: mm (in)

Model	LL	LC	LA	LZ	LG	LB	LE	Q	S	LR	Mass kg (lb)
SGMGH-03A□B	138 (5.43)	130 (5.12)	145 (5.71)	9 (0.35)	12 (0.47)	110 ⁰ _{-0.035} 433 ⁰ _{-0.0014}	6 (0.24)	40 (1.57)	19 ⁰ _{-0.013} 075 ⁰ _{-0.0005}	58 (2.28)	5.5 (12.1)
SGMGH-06A□B	161 (6.34)										7.6 (16.8)
SGMGH-09A□B	185 (7.28)								22 ⁰ _{-0.013} 087 ⁰ _{-0.0005}	9.6 (21.2)	
SGMGH-12A□B	166 (6.54)	180 (7.09)	200 (7.87)	13.5 (0.53)	18 (0.71)	114.3 ⁰ _{-0.025} 450 ⁰ _{-0.0010}	3.2 (0.13)	76 (2.99)	35 ^{0.01} ₀ 138 ^{0.0004} ₀	79 (3.11)	14 (30.9)
SGMGH-20A□B	192 (7.56)										18 (39.7)
SGMGH-30A□B	226 (8.90)										23 (50.7)
SGMGH-40A B	260 (10.2)								110 (4.33)	42 ⁰ _{-0.016} 165 ⁰ _{-0.0006}	113 (4.45)
SGMGH-55A B	334 (13.1)	40 (88.2)									

8

■ SGMSH Servomotors

Rating and Specifications for Standard Servomotors

- Time Rating: Continuous
- Vibration Class: 15 μ m or below
- Insulation Resistance: 500 VDC, 10 M Ω min.
- Ambient Temperature: 0 to 40°C
- Excitation: Permanent magnet
- Mounting: Flange method
- Thermal Class: F
- Withstand Voltage:
 - 1500 VAC for one minute (200 V specification)
 - 1800 VAC for one minute (400 V specification)
- Enclosure: Totally enclosed, IP67 self cooled (except for through sections of the shaft)
- Ambient Humidity: 20% to 80% (with no condensation)
- Drive Method: Direct drive

Table 8.6 SGMSH Standard Servomotor Ratings and Specifications

Voltage		200 V						400 V					
Servomotor Model		10A	15A	20A	30A	40A	50A	10D	15D	20D	30D	40D	50D
SGMSH-		□A	□A	□A	□A	A	A	□A	□A	□A	□A	□A	□A
Rated Output *	kW	1.0	1.5	2.0	3.0	4.0	5.0	1.0	1.5	2.0	3.0	4.0	5.0
Rated Torque *	N·m	3.18	4.9	6.36	9.8	12.6	15.8	3.18	4.9	6.36	9.8	12.6	15.8
	lb·in	28.2	43	56.4	87	112	140	28.2	43	56.4	87	112	140
Instantaneous Peak Torque *	N·m	9.54	14.7	19.1	29.4	37.8	47.6	9.54	14.7	19.1	29.4	37.8	47.6
	lb·in	84.4	130	169	260	336	422	84.4	130	169	260	336	422
Rated Current *	A (rms)	5.7	9.7	12.7	18.8	25.4	28.6	2.8	4.7	6.2	8.9	12.5	13.8
Instantaneous Max. Current *	A (rms)	17	28	42	56	77	84	8.5	14	19.5	28	38	42
Rated Speed *	r/min	3000											
Max. Speed *	r/min	5000											
Torque Constant	N·m/A (rms)	0.636	0.561	0.544	0.573	0.53	0.60	1.27	1.15	1.12	1.19	1.07	1.24
	lb·in/A (rms)	5.63	4.97	4.81	5.07	4.69	5.31	11.2	10.2	9.9	10.5	9.49	11.0
Moment of Inertia	$\times 10^{-4}$ kg·m ²	1.74	2.47	3.19	7.00	9.60	12.3	1.74	2.47	3.19	7.0	9.60	12.3
	$\times 10^{-3}$ lb·in·s ²	1.54	2.19	2.82	6.20	8.50	10.90	1.54	2.19	2.82	6.20	8.50	10.90
Rated Power Rate *	kW/s	57.9	97.2	127	137	166	202	57.9	97.2	127	137	166	202
Rated Angular Acceleration *	rad/s ²	18250	19840	19970	14000	13160	12780	18250	19840	19970	14000	13160	12780
Inertia Time Constant	ms	0.87	0.74	0.62	0.74	0.65	0.59	0.97	0.8	0.66	0.76	0.62	0.55
Inductive Time Constant	ms	7.1	7.7	8.3	13.0	14.1	14.7	6.3	6.8	7.3	16.3	14.4	15.2

* These items and torque-motor speed characteristics quoted in combination with an SGDH Servopack are at an armature winding temperature of 20°C.

Note These characteristics are values with the following heat sinks attached for cooling.

300 × 300 × 12 (mm) (12 × 12 × 0.5 (in)): 10A□A to 20A□A Servomotors, 10D□A to 20D A Servomotors

400 × 400 × 20 (mm) (16 × 16 × 0.8 (in)): 30A A to 50A□A Servomotors, 30D A Servomotors

SGMSH Servomotor Torque-Motor Speed Characteristics

The following sections provide the torque-motor speed characteristics of the SGMSH Servomotors.

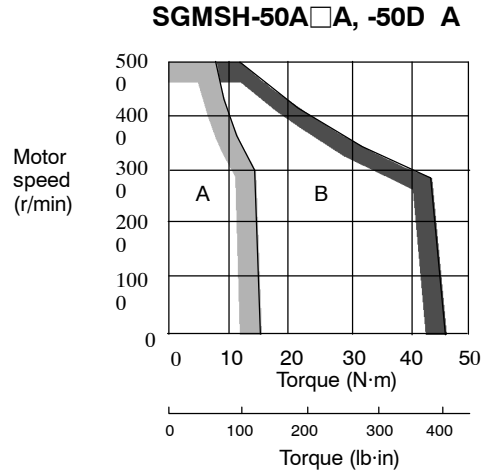
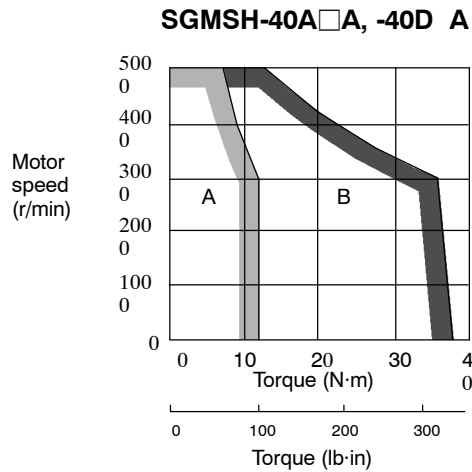
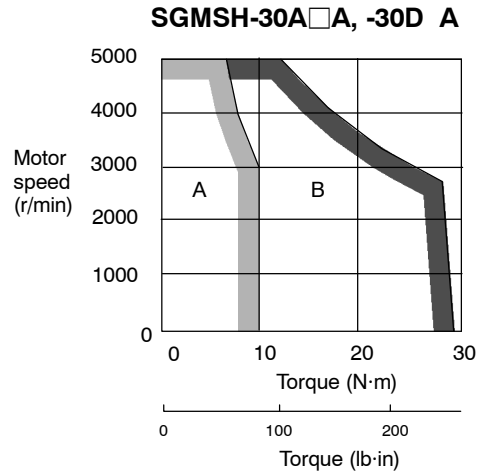
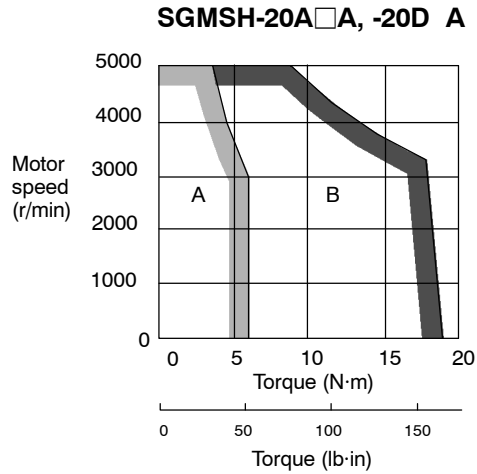
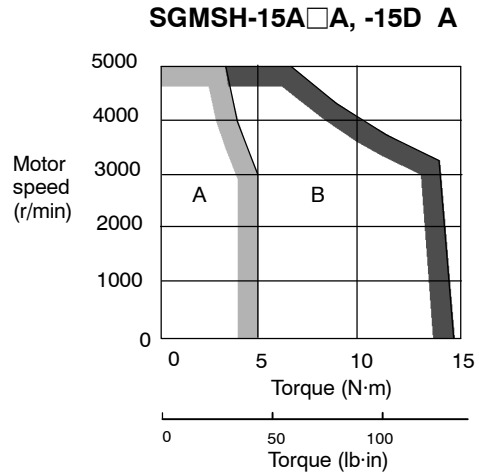
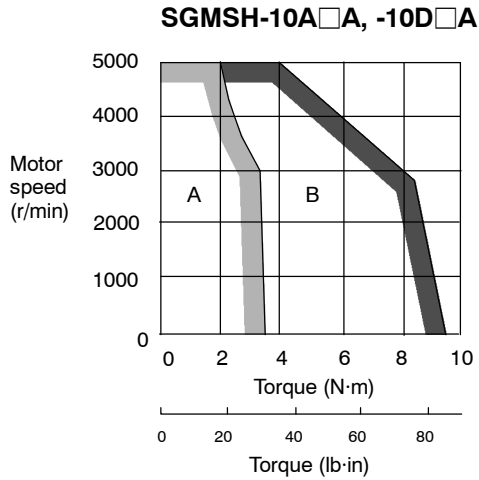

A: Continuous Duty Zone
 B: Intermittent Duty Zone

8

Dimensional Drawings

Dimensional drawings of the SGMSH Servomotors are shown below.

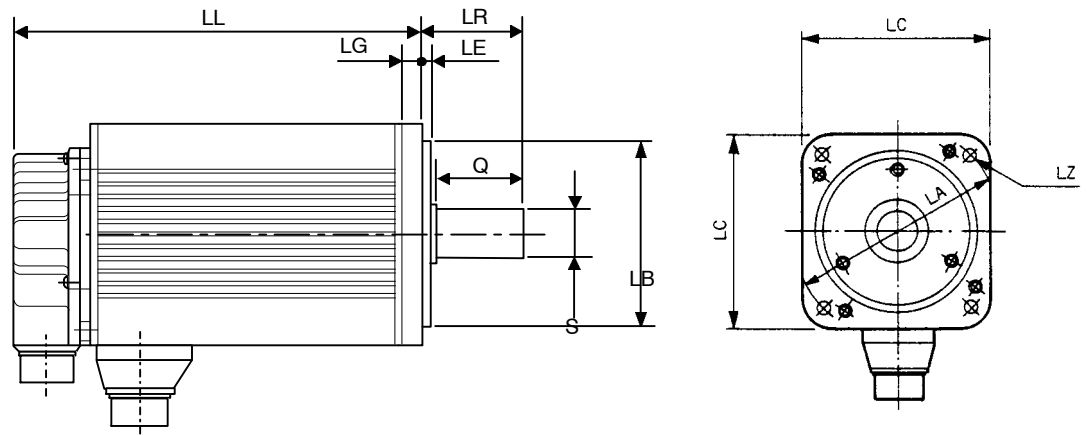

Unit: mm (in)

Model	LL	LC	LA	LZ	LG	LB	LE	Q	S	LR	Mass kg (lb)
SGMSH-10A□A -10D A	149 (5.87)	100 (3.94)	115 (4.53)	7 (0.28)	10 (0.39)	$95 \begin{matrix} 0 \\ -0.035 \end{matrix}$ $3 \begin{matrix} 0 \\ -0.0014 \end{matrix}$	3 (0.12)	40 (1.57)	$24 \begin{matrix} 0 \\ -0.013 \end{matrix}$ $0 \begin{matrix} 0 \\ -0.0005 \end{matrix}$	45 (1.77)	4.6 (10.1)
SGMSH-15A□A -15D A	175 (6.89)					5.8 (12.8)					
SGMSH-20A□A -20D A	198 (7.80)					7.0 (15.4)					
SGMSH-30A□A -30D A	199 (7.83)	130 (5.12)	145 (5.71)	9 (0.35)	12 (0.47)	$110 \begin{matrix} 0 \\ -0.035 \end{matrix}$ $4 \begin{matrix} 0 \\ -0.0014 \end{matrix}$	6 (0.24)	55 (2.17)	$28 \begin{matrix} 0 \\ -0.013 \end{matrix}$ $1 \begin{matrix} 0 \\ -0.0005 \end{matrix}$	63 (2.48)	11 (24.3)
SGMSH-40A A -40D A	236 (9.29)					14 (30.9)					
SGMSH-50A A -50D A	276 (10.9)					17 (37.5)					

■ SGMDH Servomotors

Ratings and Specifications for Standard Motors (with Holding Brakes)

- Time Rating: Continuous
- Vibration Class: 15 μm or below
- Insulation Resistance: 500 VDC, 10 M Ω min.
- Ambient Temperature: 0 to 40°C
- Excitation: Permanent magnet
- Mounting: Flange method
- Thermal Class: F
- Withstand Voltage: 1500 VAC for one minute
- Enclosure: Totally enclosed, IP67 self cooled (except for through sections of the shaft)
- Ambient Humidity: 20% to 80% (with no condensation)
- Drive Method: Direct drive
- Holding Brake: 90 VDC, static friction torque: 29.4 N·m

Table 8.7 Ratings and Specifications for Standard SGMDH Servomotors (with Holding Brakes)

Servomotor Model SGMDH-		22A A B	32A A B	40A A B
Rated Output *	kW	2.2	3.2	4.0
Rated Torque *	N·m	10.5	15.3	19.1
	lb·in	93	135	169
Instantaneous Peak Torque *	N·m	36.7	53.5	66.9
	lb·in	326	474	592
Rated Current *	A (rms)	15.7	20.9	23.2
Instantaneous Max. Current *	A (rms)	54	73	77
Rated Speed *	r/min	2000		
Max. Speed *	r/min	3000		
Torque Constant	N·m/A (rms)	0.72	0.78	0.92
	lb·in/A (rms)	6.4	6.9	8.1
Moment of Inertia	$\times 10^{-4}$ kg·m ²	56.6	74.2	91.8
	$\times 10^{-3}$ lb·in·s ²	50.3	65.9	81.5
Rated Power Rate *	kW/s	19.5	31.5	39.7
Rated Angular Acceleration *	rad/s ²	1850	2060	2080
Inertia Time Constant	ms	3.7	2.4	2.2
Inductive Time Constant	ms	16.2	18.2	17.8

* These items and torque-motor speed characteristics quoted in combination with an SGD Servopack are at an armature winding temperature of 20°C.

Note These characteristics are values with the following heat sinks attached for cooling.
650 × 650 × 35 (mm) (26 × 26 × 1.4 (in)): 22A□A□B to 40A□A□B Servomotors

SGMDH Servomotor Torque-Motor Speed Characteristics

The following sections provide the torque-motor speed characteristics of the SGMDH Servomotors.

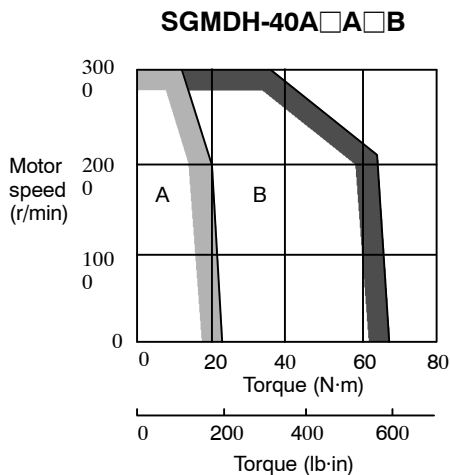
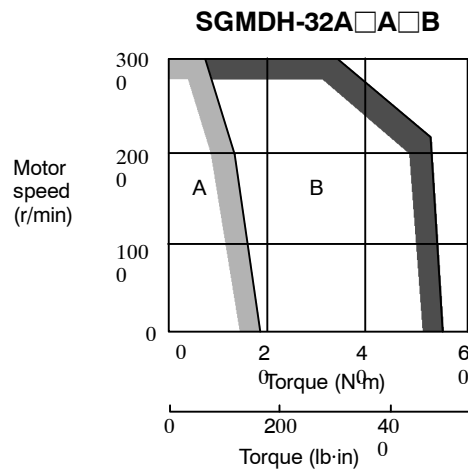
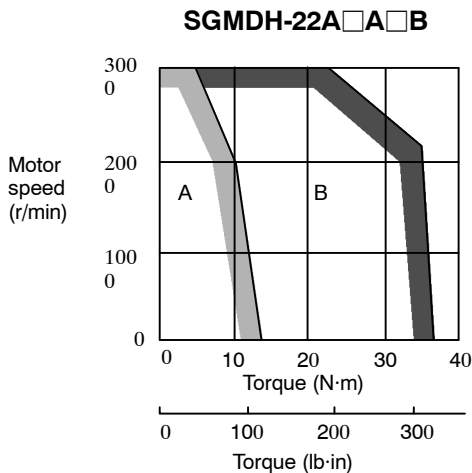

- A: Continuous Duty Zone
- B: Intermittent Duty Zone

Dimensional Drawings

Dimensional drawings of the SGMDH Servomotors are shown below.

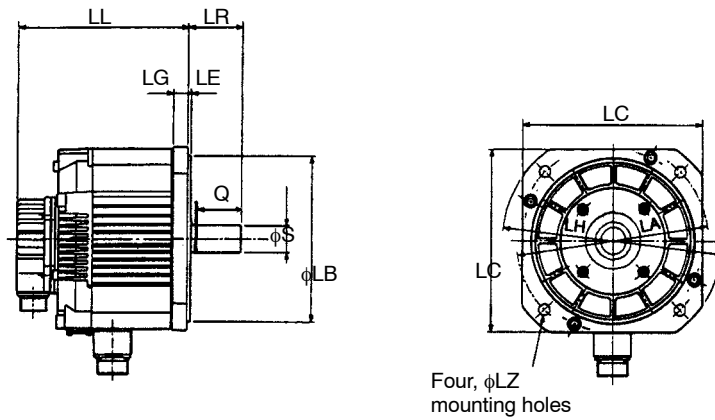

Unit: mm (in)

Model	LL	LC	LA	LZ	LG	LB	LE	Q	S	LR	Mass kg (lb)	
											W/o Brake	W/ Brake
SGMDH-22A A	187 (7.36)	220 (8.66)	235 (9.25)	13.5 (0.53)	18 (0.71)	200 ⁰ _{-0.046} 7.87 ⁰ _{-0.0018}	4 (0.16)	50 (1.97)	28 ⁰ _{-0.013} 110 ⁰ _{-0.0005}	55 (2.17)	15.5 (34.2)	20.5 (45.2)
SGMDH-32A A	199 (7.83)										18.5 (40.8)	23.5 (51.8)
SGMDH-40A A	209 (8.23)							60 (2.36)			32 ⁰ _{-0.016} 126 ⁰ _{-0.0006}	65 (2.56)

■ SGMUH Servomotors

Ratings and Specifications for Standard Motors

- Time Rating: Continuous
- Vibration Class: 15 μm or below
- Insulation Resistance: 500 VDC, 10 M Ω min.
- Ambient Temperature: 0 to 40°C
- Excitation: Permanent magnet
- Mounting: Flange method
- Thermal Class: F
- Withstand Voltage: 1800 VAC for one minute
- Enclosure: Totally enclosed, IP67 self cooled (except for through sections of the shaft)
- Ambient Humidity: 20% to 80% (with no condensation)
- Drive Method: Direct drive

Table 8.8 Ratings and Specifications for Standard SGMUH Servomotors

Servomotor Model SGMUH-		10D A	15D A	30D A	40D A
Rated Output *	kW	1.0	1.5	3.0	4.0
Rated Torque *	N·m	1.59	2.45	4.9	6.3
	lb·in	14.1	21.7	43.5	55.9
Instantaneous Peak Torque *	N·m	6.5	11	21.5	29
	lb·in	57.6	97.5	190	257
Rated Current *	A (rms)	2.7	4.1	8.1	9.6
Instantaneous Max. Current *	A (rms)	8.5	14	28	38.5
Rated Speed *	r/min	6000			
Max. Speed *	r/min	6000			
Torque Constant	N·m/A (rms)	0.81	0.83	0.81	0.80
	lb·in/A (rms)	7.2	7.4	7.2	7.1
Moment of Inertia	$\times 10^{-4}$ kg·m ²	1.74	2.47	7.0	9.6
	$\times 10^{-3}$ lb·in·s ²	1.54	2.19	6.2	8.5
Rated Power Rate *	kW/s	14.5	24.3	34.3	41.3
Rated Angular Acceleration *	rad/s ²	9130	9910	7000	6550
Inertia Time Constant	ms	0.87	0.70	0.72	0.59
Inductive Time Constant	ms	7.1	7.7	17.3	14.5

* These items and torque-motor speed characteristics quoted in combination with an SGDHD Servopack are at an armature winding temperature of 20 °C.

Note These characteristics are values with the following heat sinks attached for cooling.

300 × 300 × 12 (mm) (12 × 12 × 0.5 (in)) 10D A to 15D A Servomotors

400 × 400 × 20 (mm) (16 × 16 × 0.8 (in)) 30D A Servomotors

SGMUH Servomotor Torque-motor Speed Characteristics

The following sections provide the torque-motor speed characteristics of the SGMUH Servomotors.

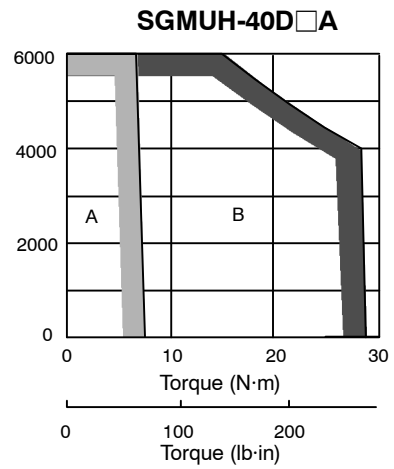
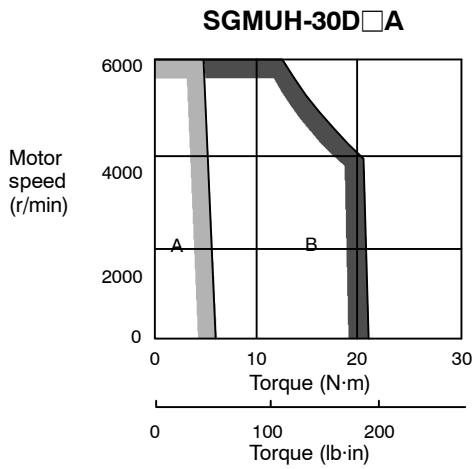
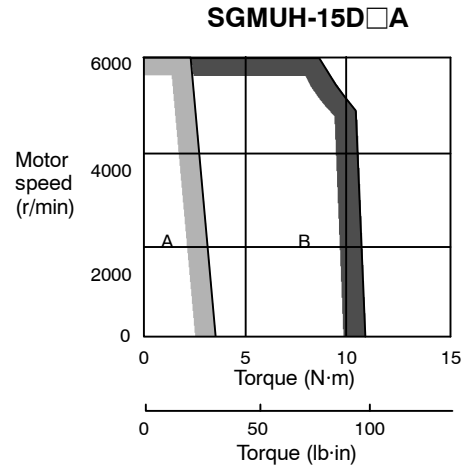
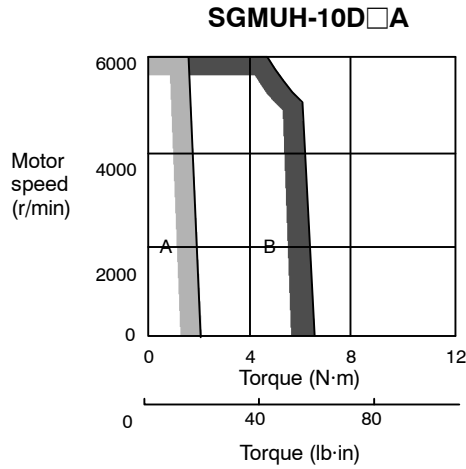

- A: Continuous Duty Zone
- B: Intermittent Duty Zone

Dimensional Drawings

Dimensional drawings of the SGMUH Servomotors are shown below.

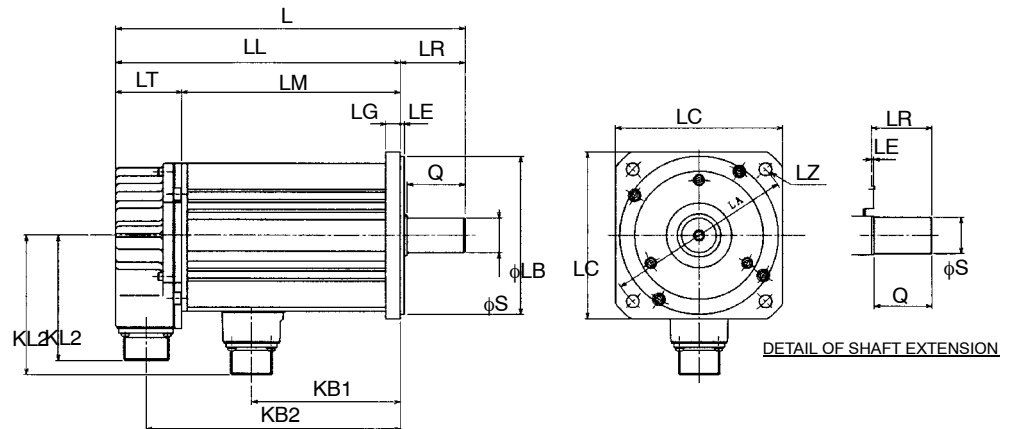

Unit: mm (in)

Model	LL	LC	LA	LZ	LG	LB	LE	Q	S	LR	Mass kg (lb)
SGMUH-10D A	149 (5.87)	116 (4.57)	130 (5.12)	9 (0.35)	10 (0.39)	110 ^{0.013} _{-0.009} 4 ₃₃ ^{0.0005} _{-0.0004}	3.5 (0.14)	40 (1.57)	24 ⁰ _{-0.013} 0 ⁰ _{-0.0005}	45 (1.77)	4.6 (10.1)
SGMUH-15D A	175 (6.89)	116 (4.57)	130 (5.12)	9 (0.35)	10 (0.39)	110 ^{0.013} _{-0.009} 4 ₃₃ ^{0.0005} _{-0.0004}	3.5 (0.14)	40 (1.57)	24 ⁰ _{-0.013} 0 ⁰ _{-0.0005}	45 (1.77)	5.8 (12.8)
SGMUH-30D A	199 (7.83)	155 (6.10)	165 (6.50)	11 (0.43)	12 (0.47)	130 ^{0.014} _{-0.011} 5 ₁₁ ^{0.0005} _{-0.0004}	3.5 (0.14)	55 (2.17)	28 ⁰ _{-0.013} 0 ⁰ _{-0.0005}	60 (2.36)	11 (24.2)
SGMUH-40D A	239 (9.41)	155 (6.10)	165 (6.50)	11 (0.43)	12 (0.47)	130 ^{0.014} _{-0.011} 5 ₁₁ ^{0.0005} _{-0.0004}	3.5 (0.14)	55 (2.17)	28 ⁰ _{-0.013} 0 ⁰ _{-0.0005}	60 (2.36)	14 (30.7)

8.2 Servopacks

This section presents tables of SGDH Servopack ratings and specifications.

8.2.1 Combined Specifications

The following table provides specifications of the SGDH Servopacks and SGMAH, SGMPH, SGMGH, SGMSH, SGMDH and SGMUH Servomotor combinations.

■ Servopack for Single-phase 100 V and Servomotor Combinations

Table 8.9 Servopack for Single-phase 100 V and SGMAH/SGMPH Servomotor Combination Specifications

Voltage			Single-phase 100 V			
Servopack Model SGDH-			A3BE	A5BE	01BE	02BE
SGMAH Series	Applicable Servomotor	Model SGMAH-	A3B	A5B	01B	02B
		Capacity kW	0.03	0.05	0.1	0.2
		Motor Speed (r/min)	Rated 3000/maximum 5000			
	Applicable Encoder		Standard: 13-bit incremental encoder			
	Continuous Output Current A (rms)		0.66	0.95	2.4	3.0
	Max. Output Current A (rms)		2.0	2.9	7.2	9.0
	Allowable Regenerative Energy*1 (Joules)		7.8	15.7		
SGMPH Series	Applicable Servomotor	Model SGMPH-	-	-	01B	02B
		Capacity kW	-	-	0.1	0.2
		Motor Speed (r/min)	Rated 3000/maximum 5000			
	Applicable Encoder		Standard: 13-bit incremental encoder			
	Continuous Output Current A (rms)		-	-	2.2	2.7
	Max. Output Current A (rms)		-	-	7.1	8.4
	Allowable Regenerative Energy*1 (Joules)		-		15.7	

* Allowable regenerative energy is the value with an AC input power supply voltage of 100 Vrms. The allowable regenerative energy may vary with power supply fluctuations.

■ Servopack for Single/Three-phase 200 V and Servomotor Combinations

Table 8.10 Servopack for Single/Three-phase 200 V and SGMAH/SGMPH Servomotor Combination Specifications

Voltage			Single-phase 200 V						Three-phase 200 V				
Servopack Model SGDH-			A3AE	A5AE	01AE	02AE	04AE	08AE-S	15AE-S	05AE	08AE	10AE	15AE
SGMAH Series	Appl-icable Servo-motor	Model SGMAH-	A3A	A5A	01A	02A	04A	08A	-	-	08A	-	-
		Capacity (kW)	0.03	0.05	0.1	0.2	0.4	0.75	-	-	0.75	-	-
		Motor Speed (r/min)	Rated 3000/maximum 5000										
	Applicable Encoder		Standard: 13-bit incremental encoder										
	Continuous Output Current A (rms)		0.44	0.64	0.91	2.1	2.8	4.4	-	-	4.4	-	-
	Max. Output Current A (rms)		1..3	2.0	2.8	6.5	8.5	13.4	-	-	13.4	-	-
	Allowable Regenerative Energy*1 (Joules)		18.5		37.1			-		-			
	Allowable Regenerative Frequency *2 (times/min)		-						-	89	-		
SGMPH Series	Appl-icable Servo-motor	Model SGMPH-	-	-	01A	02A	04A	08A	15A	-	08A	-	15A
		Capacity (kW)	-	-	0.1	0.2	0.4	0.75	1.5	-	0.75	-	1.5
		Motor Speed (r/min)	Rated 3000/maximum 5000										
	Applicable Encoder		Standard: 13-bit incremental encoder										
	Continuous Output Current A (rms)		-	-	0.89	2.0	2.6	4.1	7.5	-	4.1	-	7.5
	Max. Output Current A (rms)		-	-	2.8	6.0	8.0	13.9	23.0	-	13.9	-	23.0
	Allowable Regenerative Energy*1 (Joules)		-		37.1			-		-			
	Allowable Regenerative Frequency *2 (times/min)		-						-	29	-	17	

* 1. Allowable regenerative energy is the value with an AC input power supply voltage of 200 Vrms. The allowable regenerative energy may vary with power supply fluctuations.

* 2. Allowable regenerative frequency is the allowable frequency in the Servomotor while accelerating and decelerating through a 0 → maximum motor speed → 0 (r/min) cycle.

■ Servopack for Three-phase 200 V and Servomotor Specifications

Table 8.11 Servopack for Three-phase 200 V and SGMGH Servomotor Combination Specifications

Voltage			Three-phase 200 V										
Servopack Model SGDH-			05AE	08AE	10AE	15AE	20AE	30AE	50AE	60AE	75AE	1AAE	1EAE
SGMGH Series	Appli- cable Servo- motor	Model SGMGH-	05A□A	-	09A□ A	13A□ A	20A□ A	30A□ A	44A□ A	55A□ A	75A□ A	1AA- □A	1EA- □A
		Capacity (kW)	0.45	-	0.85	1.3	1.8	2.9	4.4	5.5	7.5	11	15
		Motor Speed (r/min)	Rated 1500/maximum 3000										Rated 1500/ maximum 2000
	Applicable Encoder		Standard: 17-bit incremental encoder										
	Continuous Output Current A (rms)		3.8	-	7.1	10.7	16.7	23.8	32.8	42.1	54.7	58.6	78.0
	Max. Output Cur- rent A (rms)		11	-	17	28	42	56	84	110	130	140	170
	Allowable Regenerative Frequency *1 (times/min)		34	-	13	10	12	8	11	26*2	36*2	36*2	36*2
SGMGH Series	Appli- cable Servo- motor	Model SGMGH-	03A□B	06A□ B	09A□ B	12A□ B	20A□ B	30A□ B	40A□ B	55A□ B	-	-	-
		Capacity (kW)	0.3	0.6	0.9	1.2	2.0	3.0	4.0	5.5	-	-	-
		Motor Speed (r/min)	Rated 1000/maximum 2000										
	Applicable Encoder		Standard: 17-bit incremental encoder										
	Continuous Output Current A (rms)		3.0	5.7	7.6	11.6	18.5	24.8	30	43.2	-	-	-
	Max. Output Cur- rent A (rms)		7.3	13.9	16.6	28	42	56	84	110	-	-	-
	Allowable Regenerative Frequency *1 (times/min)		96	39	22	15	20	13	20	44*2	-	-	-

* 1. Allowable regenerative frequency is the allowable frequency in the Servomotor while accelerating and decelerating through a 0 → maximum motor speed → 0 (r/min) cycle.

* 2. The regenerative frequency for motor combinations with the SGDH-60AE to -1EAE assume that the JUSP-RA04 or JUSP-RA05 Regenerative Resistor Unit is used. For information on Regenerative Resistor Units, refer to 5.6.1 External Regenerative Resistors or to 5.2.5 Regenerative Resistor Units in the Σ-II Series SGM-□H/SGDH User's Manual: Servo Selection and Datasheets (manual number: SIE-S800-32.1).

Table 8.12 Servopack for Three-phase 200 V and SGMSH/SGMDH Servomotor Combination Specifications

Voltage			Three-phase 200 V								
Servopack Model SGDH-			05AE	08AE	10AE	15AE	20AE	30AE	50AE		
SGMSH Series	Applicable Servomo- tor	Model SGMSH-	-	-	10A	15A	20A	30A	40A	50A	
		Capacity (kW)	-	-	1.0	1.5	2.0	3.0	4.0	5.0	
		Motor Speed (r/min)	Rated 3000/maximum 5000								
	Applicable Encoder		Standard: 17-bit incremental encoder								
	Continuous Output Current A (rms)		-	-	5.7	9.7	12.7	18.8	25.4	28.6	
	Max. Output Current A (rms)		-	-	17	28	42	56	77	84	
	Allowable Regenerative Frequency * (times/min)		-	-	39	31	48	20	29	22	
SGMDH Series	Applicable Servomo- tor	Model SGMDH-	-	-	-	-	-	22A	32A	40A	
		Capacity (kW)	-	-	-	-	-	2.2	3.2	4.0	
		Motor Speed (r/min)	Rated 2000/maximum 3000								
	Applicable Encoder		Standard: 17-bit incremental encoder								
	Continuous Output Current A (rms)		-	-	-	-	-	15.7	20.9	23.2	
	Max. Output Current A (rms)		-	-	-	-	-	54	73	77	
	Allowable Regenerative Frequency * (times/min)		-	-	-	-	-	7	11	8	

* Allowable regenerative frequency is the allowable frequency in the Servomotor while accelerating and decelerating through a 0 → maximum motor speed → 0 (r/min) cycle.

■ Servopack for Three-phase 400 V and Servomotor Combinations

Table 8.13 Servopack for Three-phase 400 V and SGMGH/SGMSH/SGMUH Servomotor Combination Specifications

Voltage			Three-phase 400 V									
Servopack Model SGDH-			05DE	10DE	15DE	20DE	30DE	50DE	60DE	75DE	1ADE	1EDE
SGMGH Series	Applicable Servomotor	Model SGMGH-	05D	09D	13D	20D	30D	44D	55D	75D	1AD	1ED
		Capacity (kW)	0.45	0.85	1.3	1.8	2.9	4.4	5.5	7.5	11	15
		Motor Speed (r/min)	Rated 1500/maximum 3000									Rated 1500/maximum 2000
	Applicable Encoder		Standard: 17-bit incremental encoder									
	Continuous Output Current A (rms)		1.9	3.5	5.4	8.4	11.9	16.5	20.8	25.4	28.1	37.2
	Max. Output Current A (rms)		5.5	8.5	14	20	28	40.5	55	65	70	85
	Allowable Regenerative Frequency * (times/min)		42	15	10	12	8	11	26	18	36	32
SGMSH Series	Applicable Servomotor	Model SGMSH-	-	10D	15D	20D	30D	40D	50D	-		
		Capacity (kW)	-	1.0	1.5	2.0	3.0	4.0	5.0	-		
		Motor Speed (r/min)	Rated 3000/maximum 5000									
	Applicable Encoder		Standard: 17-bit incremental encoder									
	Continuous Output Current A (rms)		-	2.8	4.7	6.2	8.9	12.5	13.8	-		
	Max. Output Current A (rms)		-	8.5	14	19.5	28	38	42	-		
	Allowable Regenerative Frequency * (times/min)		-	47	31	48	20	29	22	-		
SGMUH Series	Applicable Servomotor	Model SGMUH-	-	10D	15D	-	30D	40D	-			
		Capacity (kW)	-	1.0	1.5	-	3.0	4.0	-			
		Motor Speed (r/min)	Rated 6000/maximum 6000									
	Applicable Encoder		Standard: 17-bit incremental encoder									
	Continuous Output Current A (rms)		-	2.7	4.1	-	8.1	9.6	-			
	Max. Output Current A (rms)		-	8.5	14	-	28	38.5	-			
	Allowable Regenerative Frequency * (times/min)		-	27	19	-	13	19	-			

* Allowable regenerative frequency is the allowable frequency in the Servomotor while accelerating and decelerating through a 0 → maximum motor speed → 0 (r/min) cycle.



Refer to *Section 5.6 Selecting a Regeneration Resistor* for more details on allowable regenerative energy and frequency.

8.2.2 Ratings and Specifications

The following table shows ratings and specifications for the SGDH Servopack. Refer to them as required when selecting a Servopack.

Table 8.14 Servopack Ratings and Specifications

Servopack Model SGDH-			A3	A5	01	02	04	05	08	10	15	20	30	
Appli- cable Servo- motor	100V	SGMAH-□B	A3	A5	01	02	-	-	-	-	-	-	-	
		SGMPH-□B	-	-	01	02	-	-	-	-	-	-	-	
	200V	SGMAH-□A	A3	A5	01	02	04	-	08	-	-	-	-	
		SGMPH-□A	-	-	01	02	04	-	08	-	15	-	-	
		SGMGH-□A□A (1500r/min)	-	-	-	-	-	05	-	09	13	20	30	
		SGMGH-□A□B (1000r/min)	-	-	-	-	-	03	06	09	12	20	30	
		SGMSH-□A	-	-	-	-	-	-	-	10	15	20	30	
		SGMDH-□A	-	-	-	-	-	-	-	-	-	-	22	
	400V	SGMGH-□D	-	-	-	-	-	05	-	09	13	20	30	
		SGMSH-□D	-	-	-	-	-	-	-	10	15	20	30	
SGMUH-□D		-	-	-	-	-	-	-	10	15	-	30		
Basic Specifi- cations	Max. Applicable Servomotor Capacity [kW]		0.03	0.05	0.1	0.2	0.4	0.45	0.75	1.0	1.5	2.0	3.0	
	100V	Continuous Output Current [A rms]	0.66	0.95	2.4	3.0	-	-	-	-	-	-	-	
		Max. Output Current [A rms]	2.0	2.9	7.2	9.0	-	-	-	-	-	-	-	
	200V	Continuous Output Current [A rms]	0.44	0.64	0.91	2.1	2.8	3.8	5.7	7.6	11.6	18.5	24.8	
		Max. Output Current [A rms]	1.3	2.0	2.8	6.5	8.5	11.0	13.9	17	28	42	56	
	400V	Continuous Output Current [A rms]	-	-	-	-	-	1.9	-	3.5	5.4	8.4	11.9	
		Max. Output Current [A rms]	-	-	-	-	-	5.5	-	8.5	14	20	28	
	Input Power Supply *1	Main circuit	100 V	Single-phase 100 to 115 VAC +10 to -15%, 50/60 Hz										
			200 V	Single/Three-phase 200 to 230 VAC +10 to -15%, 50/60 Hz*6										
			400 V	Three-phase 380 to 480 VAC +10 to -15%, 50/60 Hz										
		Control circuit	100 V	Single-phase 100 to 115 VAC +10 to -15%, 50/60 Hz										
			200 V	Single-phase 200 to 230 VAC +10 to -15%, 50/60 Hz										
			400 V	24 VDC 15%										
	Control Method		Single or three-phase full-wave rectification IGBT-PWM (sine-wave driven)											
	Feedback		Serial encoder: 13, 16 or 17-bit (incremental/absolute value) * The 13 bit encoder is incremental only.											
Condi- tions	Ambient/Storage Temperature *2		0 to +55°C/-20 to +85°C											
	Ambient/Storage Humidity		90% RH or less (with no condensation)											
	Vibration/Shock Resistance		4.9 m/s ² /19.6 m/s ²											
Configuration		Base mounted (Can be rack mounted with optional specifications.)												

Servopack Model SGDH-			A3	A5	01	02	04	05	08	10	15	20	30	
Speed and Torque Control Modes	Performance	Speed Control Range		1:5000 (The lowest speed of the speed control range is the speed at which the Servomotor will not stop with a rated torque load.)										
		Speed Regulation *3	Load Regulation	0 to 100% load: 0.01% max. (at rated speed)										
			Voltage Regulation	Rated Voltage $\pm 10\%$: 0% (at rated speed)										
			Temperature Regulation	25 ± 25 °C: $\pm 0.1\%$ max. (at rated speed)										
		Frequency Characteristics		400 Hz (at $J_L = J_M$)										
		Torque Control Tolerance (Repeatability)		$\pm 2\%$										
	Soft Start Time Setting		0 to 10 s (Can be set individually for acceleration and deceleration.)											
	Input Signals	Speed Reference Input	Reference Voltage *4	± 6 VDC (Variable setting range: ± 2 to ± 10 VDC) at rated torque (positive torque reference with positive reference), input voltage: ± 12 V (max.)										
			Input Impedance	About 14 k Ω										
			Circuit Time Constant	About 47 μ s										
		Torque Reference Input	Reference Voltage *4	± 3 VDC (Variable setting range: ± 1 to ± 10 VDC) at rated torque (positive torque reference with positive reference), input voltage: ± 12 V (max.)										
			Input Impedance	About 14 k Ω										
			Circuit Time Constant	About 47 μ s										
		Contact Speed Reference	Rotation Direction Selection	With P control signal										
			Speed Selection	With forward/reverse current limit signal (speed 1 to 3 selection), Servomotor stops or another control method is used when both are OFF.										
	Position Control Modes	Performance	Bias Setting		0 to 450 r/min (setting resolution: 1 r/min)									
			Feed Forward Compensation		0 to 100% (setting resolution: 1%)									
Positioning Completed Width Setting			0 to 250 reference units (setting resolution: 1 reference unit)											
Input Signals		Reference Pulse	Type	Sign + pulse train, 90° phase difference 2-phase pulse (A phase + B phase), or CCW + CW pulse train										
			Form	Line driver (+5 V level), open collector (+5 V or +12 V level)										
			Frequency	500/200 kpps max. (line driver/open collector)										
Control Signal		Clear Signal (input pulse form identical to reference pulse)												
Built-in Open Collector Power Supply *5		+12 V (1-k Ω resistor built in)												

Servopack Model SGDH-			A3	A5	01	02	04	05	08	10	15	20	30		
I/O Signals	Position Output	Form	A-, B-, C-phase line driver S-phase line driver (only with an absolute encoder)												
		Frequency Dividing Ratio	Any												
	Sequence Input	Signal allocation can be modified. Sequence Input	Servo ON, P control (or Control Mode switching, forward/reverse motor rotation by internal speed setting, zero clamping, reference pulse prohibited), forward run prohibited (P-OT), reverse run prohibited (N-OT), alarm reset, forward current limit and reverse current limit (or internal speed selection)												
	Sequence Output	Fixed Output	Servo alarm, 3-bit alarm codes												
Signal allocation can be modified.		Positioning completed (speed coincidence), during Servomotor rotation, servo ready, during current limiting, during speed limiting, brake released, warning, selecting three of the NEAR signals.													
Internal Functions	Dynamic Brake		Operated at main power OFF, servo alarm, servo OFF or overtravel.												
	Regeneration		External regenerative resistor							Built-in					
	Overtravel Stop		Dynamic brake stop at P-OT or N-OT, deceleration to a stop, or free run to a stop												
	Electronic Gear		0.01 □ B/A □ 100												
	Protection		Overcurrent, overvoltage, low voltage, overload, regeneration error, main circuit voltage error, heat sink overheated, no power supply, overflow, overspeed, encoder error, overrun, CPU error, parameter error, etc.												
	LED Display		Charge, Power, five 7-segment LEDs (built-in Digital Operator functions)												
	CN5 Analog Monitoring		Analog monitor connector built in for monitoring speed, torque and other reference signals. Speed: 1 V/1000 r/min Torque: 1 V/rated torque Pulses remaining: 0.05 V/1 reference units or 0.05 V/100 reference units												
	Communications	Connected Devices		Digital Operator (hand-held model), RS-422A port such as for a personal computer (RS-232C ports under certain conditions)											
		1:N Communications		Up to N = 14 for RS-422A ports											
		Axis Address Setting		Set with user constants.											
Functions		Status display, user constant setting, monitor display, alarm trace-back display, JOG and auto-tuning operations, speed, torque reference signal and other drawing functions.													
Others		Reverse rotation connection, origin search, automatic Servomotor ID, DC reactor connection terminal for high power supply frequency control													

* 1. Supply voltage must not exceed the following values. Otherwise, Servopack may malfunction. If the voltage exceeds these values, use a step-down transformer so that the voltage will be within the specified range.

Servopack for 100 V 127 Vrms (max.)

Servopack for 200 V 253 Vrms (max.)

Servopack for 400 V 528 Vrms (max.)

* 2. Use the Servopack within the ambient temperature range. When enclosed in a box, internal temperatures must not exceed the ambient temperature range.

* 3. Speed regulation is defined as follows:

$$\text{Speed regulation} = \frac{\text{No-load motor speed} - \text{Total load motor speed}}{\text{Rated motor speed}} \times 100\%$$

The motor speed may change due to voltage variations or amplifier drift and changes in processing resistance due to temperature variation. The ratio of speed changes to the rated speed represent speed regulation due to voltage and temperature variations.

* 4. Forward is clockwise viewed from the non-load side of the Servomotor. (Counterclockwise viewed from the load and shaft end)

* 5. The built-in open collector power supply is not electrically insulated from the control circuit in the Servopack.

* 6. Main circuit power supply for SGDH-08AE-S/SGDH-15AE-S Servopacks are as follows

Single-phase 220 to 230 VAC +10 to -15%, 50/60 Hz

When a power supply of 187 V (-15% of 220 V) or less is used, alarm 41, indicating voltage shortage, may occur when accelerating to max speed with max torque of Servomotor.

Table 8.15 Servopack Ratings and Specifications 2

Servopack Model SGDH-			50	60	75	1A	1E	
Appli- cable Servo- motor	200V	SGMGH-□A□A (1500r/min)	44	55	75	1A	1E	
		SGMGH-□A□B (1000r/min)	40	55	-	-	-	
		SGMSH-□A	40	50	-	-	-	
		SGMDH-□A	40	-	-	-	-	
	400V	SGMGH-□D	44	55	75	1A	1E	
		SGMSH-□D	40	50	-	-	-	
SGMUH-□D		40	-	-	-	-		
Basic Specifi- cations	Max. Applicable Servomotor Capacity [kW]		5.0	6.0	7.5	11	15	
	200V	Continuous Output Current [A rms]	32.9	46.9	54.7	58.6	78.0	
		Max. Output Current [A rms]	84	110	130	140	170	
	400V	Continuous Output Current [A rms]	16.5	20.8	25.4	28.1	37.2	
		Max. Output Current [A rms]	40.5	55	65	70	85	
	Input Power Supply *1	Main circuit	200 V	Three-phase 200 to 230 VAC +10 to -15%, 50/60 Hz				
			400 V	Three-phase 380 to 480 VAC +10 to -15%, 50/60 Hz				
		Control Circuit	200 V	Single-phase 200 to 230 VAC +10 to -15%, 50/60 Hz				
			400 V	24 VDC 15%				
	Control Method			Three-phase full-wave rectification IGBT-PWM (sine-wave driven)				
Feedback			Serial encoder: 13, 16 and 17-bit (incremental/absolute value) * The 13 bit encoder is incremental only.					

8

Servopack Model SGDH-			50	60	75	1A	1E
Basic Specifications	Condi- tions	Ambient/Storage Temperature *2	0 to +55°C/-20 to +85°C				
		Ambient/Storage Humidity	90% RH or less (with no condensation)				
		Vibration/Shock Resistance	4.9 m/s ² /19.6 m/s ²				
	Configuration		Base mounted (Can be rack mounted with optional specifications.)	Base mounted (Can be duct ventilated with optional specifications.)			
Speed and Torque Control Modes	Perfor- mance	Speed Control Range		1:5000 (The lowest speed of the speed control range is the speed at which the Servomotor will not stop with a rated torque load.)			
		Speed Regu- lation *3	Load Regu- lation	0 to 100% load: 0.01% max. (at rated speed)			
			Voltage Regulation	Rated Voltage ±10%: 0% (at rated speed)			
			Tempera- ture Regu- lation	25 ± 25 °C: ±0.1% max. (at rated speed)			
		Frequency Charac- teristics		400 Hz (at J _L = J _M)			
		Torque Control Toler- ance (Repeatability)		±2%			
		Soft Start Time Set- ting		0 to 10 s (Can be set individually for acceleration and deceleration.)			
	Input Signals	Speed Refer- ence In- put	Reference Voltage *4	±6 VDC (Variable setting range: ±2 to ±10 VDC) at rated torque (positive torque reference with positive reference), input voltage: ±12 V (max.)			
			Input Im- pedance	About 14 kΩ			
			Circuit Time Constant	About 47 μs			
		Torque Refer- ence In- put	Reference Voltage *4	±3 VDC (Variable setting range: ±1 to ±10 VDC) at rated torque (positive torque reference with positive reference), input voltage: ±12 V (max.)			
			Input Im- pedance	About 14 kΩ			
			Circuit Time Constant	About 47 μs			
		Contact Speed Refer- ence	Rotation Direction Selection	With P control signal			
Speed Selection			With forward/reverse current limit signal (speed 1 to 3 selection), Servomotor stops or another control method is used when both are OFF.				

Servopack Model SGDH-			50	60	75	1A	1E	
Position Control Modes	Performance	Bias Setting	0 to 450 r/min (setting resolution: 1 r/min)					
		Feed Forward Compensation	0 to 100% (setting resolution: 1%)					
		Positioning Completed Width Setting	0 to 250 reference units (setting resolution: 1 reference unit)					
	Input Signals	Reference Pulse	Type	Sign + pulse train, 90° phase difference 2-phase pulse (A phase + B phase), or CCW + CW pulse train				
			Form	Line driver (+5 V level), open collector (+5 V or +12 V level)				
			Frequency	500/200 kpps max. (line driver/open collector)				
		Control Signal	Clear Signal (input pulse form identical to reference pulse)					
Built-in Open Collector Power Supply *5	+12 V (1-kΩ resistor built in)							
I/O Signals	Position Output	Form	A-, B-, C-phase line driver S-phase line driver (only with an absolute encoder)					
		Frequency Dividing Ratio	Any					
	Sequence Input	Signal allocation can be modified.	Servo ON, P control (or Control Mode switching, forward/reverse motor rotation by internal speed setting, zero clamping, reference pulse prohibited), forward run prohibited (P-OT), reverse run prohibited (N-OT), alarm reset, forward current limit and reverse current limit (or internal speed selection)					
	Sequence Output	Fixed Output	Servo alarm, 3-bit alarm codes					
		Signal allocation can be modified.	Positioning completed (speed coincidence), during Servomotor rotation, servo ready, during current limiting, during speed limiting, brake released, warning, selecting three of the NEAR signals.					

Servopack Model SGDH-		50	60	75	1A	1E
Internal Func- tions	Dynamic Brake		Operated at main power OFF, servo alarm, servo OFF or overtravel.			
	Regeneration		Built-in	External regenerative resistor		
	Overtravel Stop		Dynamic brake stop at P-OT or N-OT, deceleration to a stop, or free run to a stop			
	Electronic Gear		0.01 □ B/A □ 100			
	Protection		Overcurrent, overvoltage, low voltage, overload, regeneration error, main circuit voltage error, heat sink overheated, no power supply, overflow, overspeed, encoder error, overrun, CPU error, parameter error, etc.			
	LED Display		Charge, Power, five 7-segment LEDs (built-in Digital Operator functions)			
	CN5 Analog Monitoring		Analog monitor connector built in for monitoring speed, torque and other reference signals. Speed: 1 V/1000 r/min Torque: 1 V/rated torque Pulses remaining: 0.05 V/1 reference units or 0.05 V/100 reference units			
	Communications	Connected Devices	Digital Operator (hand-held model), RS-422A port such as for a personal computer (RS-232C ports under certain conditions)			
		1:N Communications	Up to N = 14 for RS-422A ports			
		Axis Address Setting	Set with user constants.			
Functions		Status display, user constant setting, monitor display, alarm trace-back display, JOG and auto-tuning operations, speed, torque reference signal and other drawing functions.				
Others		Reverse rotation connection, origin search, automatic Servomotor ID, DC reactor connection terminals for high power supply frequency control ^{*6}				

* 1. Supply voltage must not exceed 230 V +10% (253 V). A step-down transformer is required if the voltage exceeds these values.

* 2. Use the Servopack within the ambient temperature range. When enclosed in a box, internal temperatures must not exceed the ambient temperature range.

* 3. Speed regulation is defined as follows:

$$\text{Speed regulation} = \frac{\text{No-load motor speed} - \text{Total load motor speed}}{\text{Rated motor speed}} \times 100\%$$

The motor speed may change due to voltage variations or amplifier drift and changes in processing resistance due to temperature variation. The ratio of speed changes to the rated speed represent speed regulation due to voltage and temperature variations.

* 4. Forward is clockwise viewed from the non-load side of the Servomotor. (Counterclockwise viewed from the load and shaft end)

* 5. The built-in open collector power supply is not electrically insulated from the control circuit in the Servopack.

* 6. The DC reactor connection terminals for power supplies designed for minimum harmonics are not included in Servopacks with capacities of 6 kW or more.

8.2.3 Dimensional Drawings

Dimensional drawings of the Base Mounting Standard Servopacks are shown below. For detailed dimensional drawings, refer to *Servo Selection and Data Sheets*.

For details of the Rack Mounting and Duct-ventilated Servopacks, refer also to *Servo Selection and Data Sheets*.

■ Base Mounting Models

Unit: mm (in)

SGDH-A3BE to -01BE (Single-phase, 100 V, 30 to 100W)
SGDH-A3AE to -02AE (Single-phase, 200 V, 30 to 200 W)

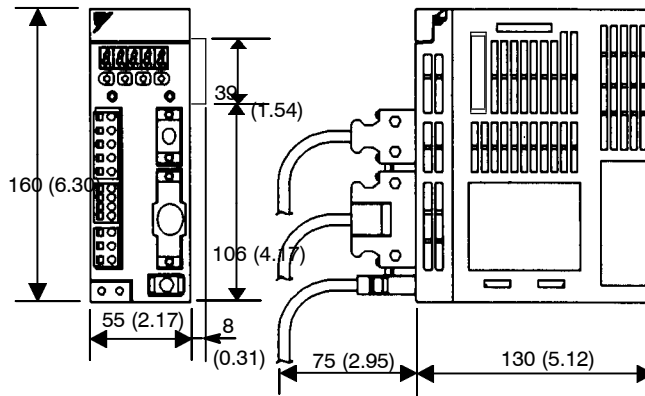

Approx. mass: 0.8 kg (1.76 lb)

SGDH-02BE (Single-phase, 100 V, 200 W)
SGDH-04AE (Single-phase, 200 V, 400 W)

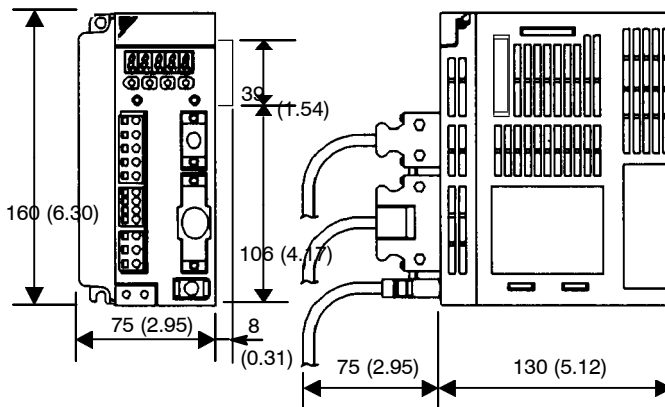

Approx. mass: 1.1 kg (2.43 lb)

SGDH-05AE to-10AE (Three-phase, 200 V, 0.5 to 1.0 kW)

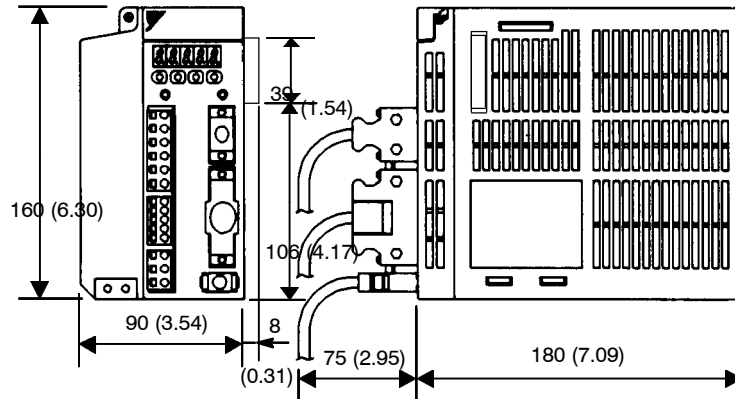

Approx. mass: 1.7 kg (3.75 lb)

SGDH-15AE (Three-phase, 200 V, 1.5 kW) SGDH-05DE to -15DE (Three-phase, 400 V, 0.5 to 1.5kW)

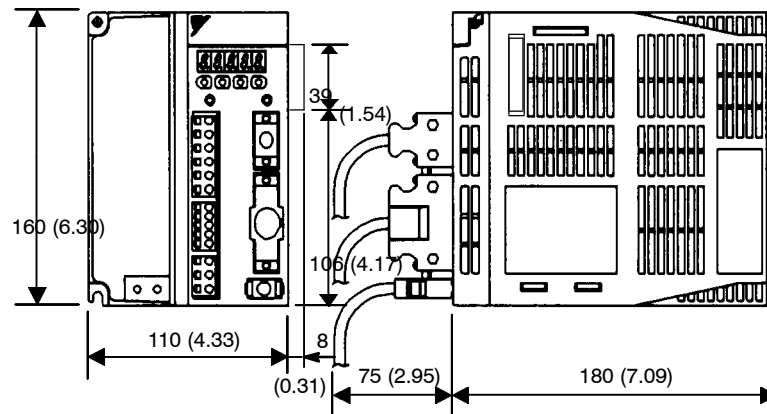

Approx. mass: 2.8 kg (6.17 lb)

SGDH-20AE, -30AE (Three-phase, 200 V, 2.0 kW, 3.0 kW)
SGDH-20DE, -30DE (Three-phase, 400 V, 2.0 kW, 3.0 kW)

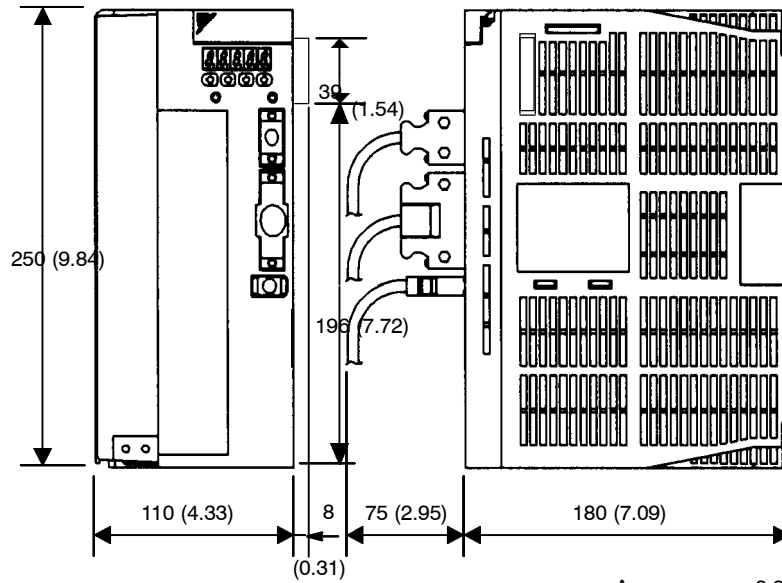

Approx. mass: 3.8 kg (8.38 lb)

SGDH-50AE (Three-phase, 200 V, 5.0 kW)

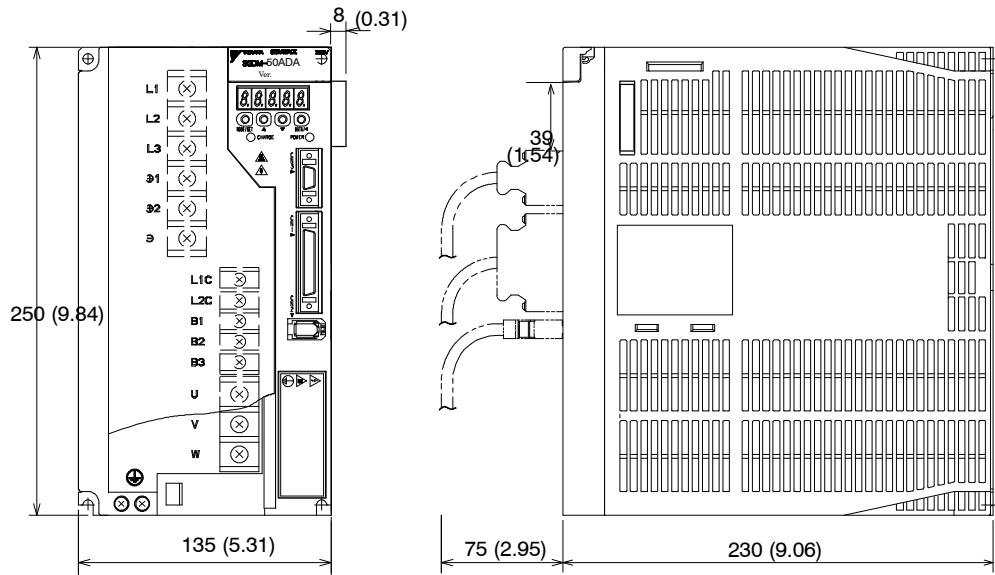

Approx. mass: 5.5 kg (12.1 lb)

SGDH-50DE (Three-phase, 400 V, 5.0 kW)

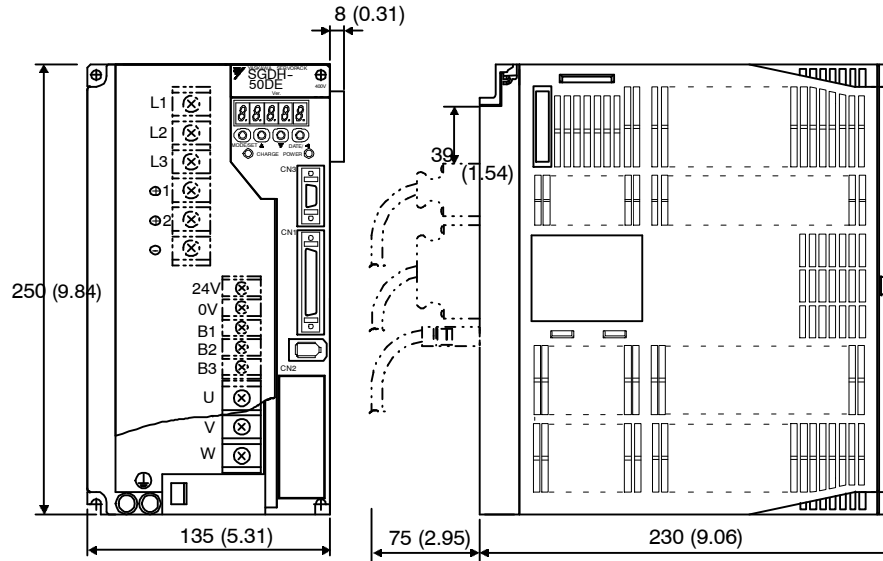

Approx. mass: 5.5 kg (12.1 lb)

SGDH-60AE, -75AE (Three-phase, 200 V, 6.0 kW, 7.5 kW)

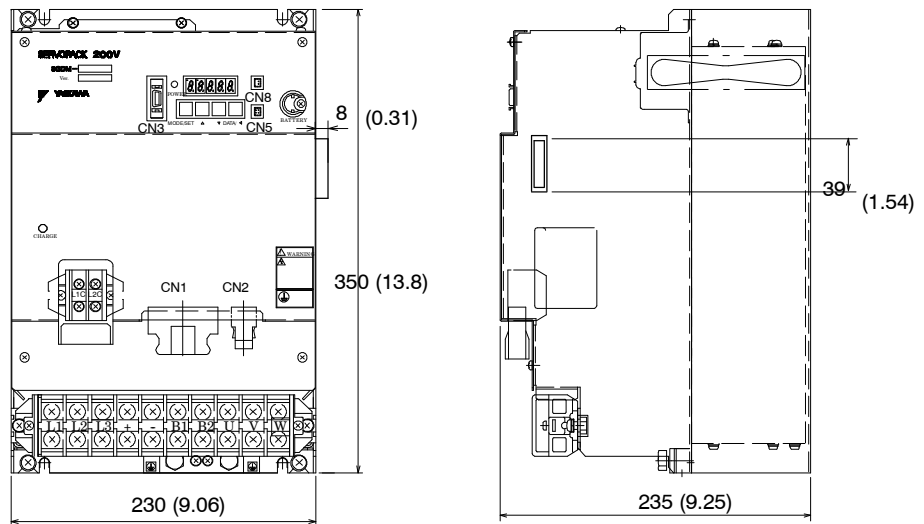

Approx. mass: 14.3 kg (31.5 lb)

SGDH-60DE, -75DE (Three-phase, 400 V, 6.0 kW, 7.5 kW)

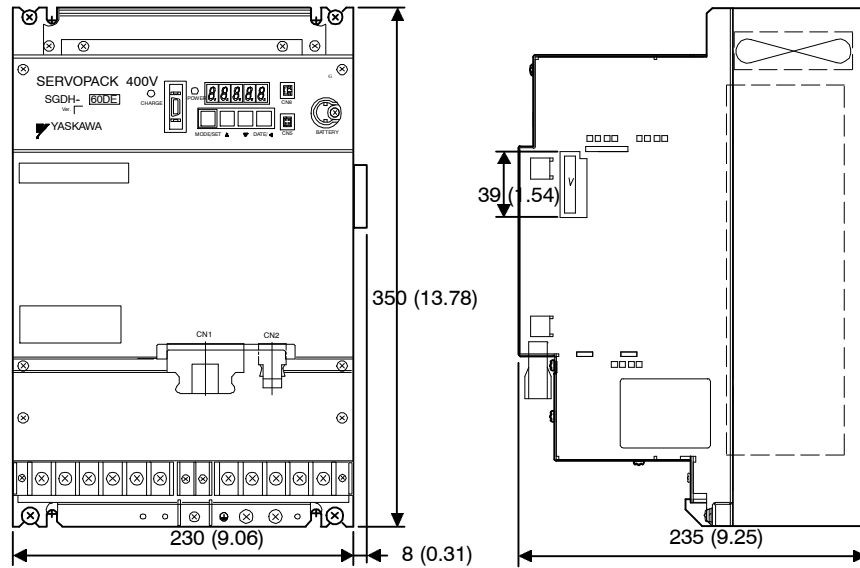

Approx. mass: 13.5 kg (29.8 lb)

SGDH-1AAE, -1EAE (Three-phase, 200 V, 11.0 kW, 15.0 kW)

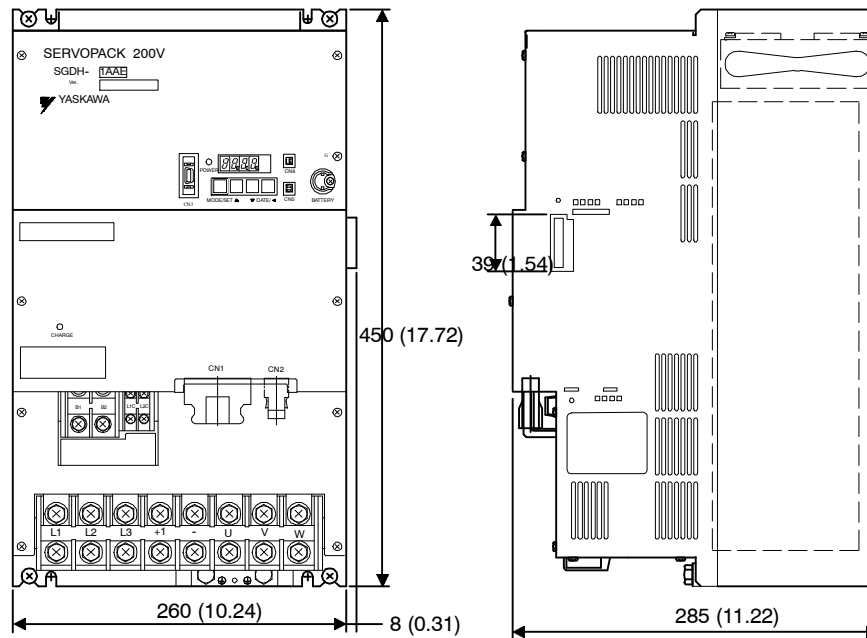

Approx. mass: 26 kg (57.3 lb)

8

SGDH-1ADE, -1EDE (Three-phase, 400 V, 11.0 kW, 15.0 kW)

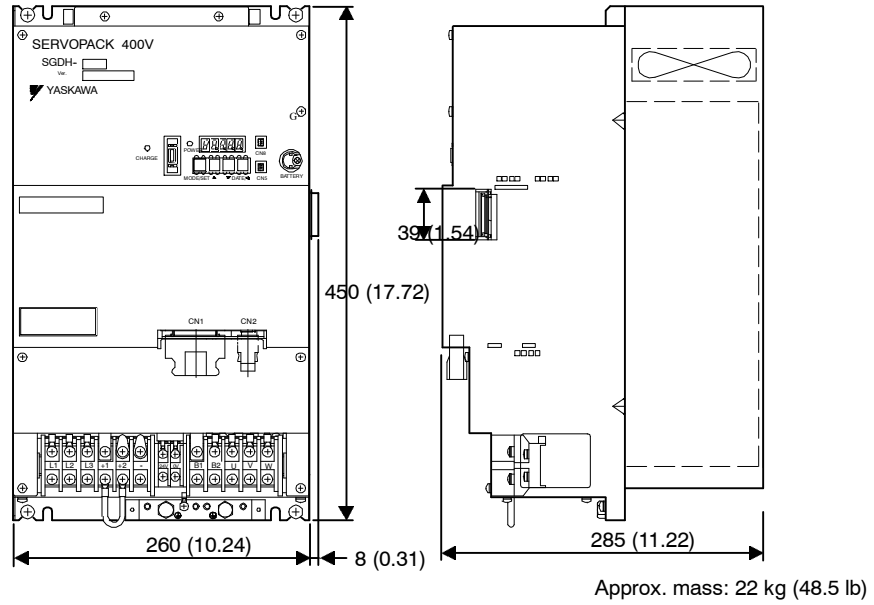



9

Inspection, Maintenance, and Troubleshooting

This chapter describes the basic inspection and maintenance to be carried out by the user. In addition, troubleshooting procedures are described for problems which cause an alarm display and for problems which result in no alarm display.

9.1 Servodrive Inspection and Maintenance . . .	9 - 2
9.1.1 Servomotor Inspection	9 - 2
9.1.2 Servopack Inspection	9 - 3
9.1.3 Replacing Battery for Absolute Encoder	9 - 4
9.2 Troubleshooting	9 - 5
9.2.1 Troubleshooting Problems with Alarm Displays . . .	9 - 5
9.2.2 Troubleshooting Problems with No Alarm Display .	9- 32
9.2.3 Alarm Display Table	9 - 34
9.2.4 Warning Displays	9 - 36

9.1 Servodrive Inspection and Maintenance

This section describes the basic inspections and maintenance of Servomotors and Servopacks and the procedures for replacing the battery for absolute encoders.

9.1.1 Servomotor Inspection

For inspection and maintenance of Servomotors, follow the simple, daily inspection procedures in the following table.

The AC Servomotors are brushless. Simple, daily inspection is sufficient. The inspection and maintenance frequencies in the table are only guidelines. Increase or decrease the frequency to suit the operating conditions and environment.

IMPORTANT

During inspection and maintenance, do not disassemble the Servomotor. If disassembly of the Servomotor is required, contact your Yaskawa representative.

Table 9.1 Servomotor Inspections

Item	Frequency	Procedure	Comments
Vibration and Noise	Daily	Touch and listen.	Levels higher than normal?
Exterior	According to degree of contamination	Clean with cloth or compressed air.	-
Insulation Resistance Measurement	At least once a year	Disconnect Servopack and test insulation resistance at 500 V. Must exceed 10 M Ω .*	Contact your Yaskawa representative if the insulation resistance is below 10 M Ω .
Replacing Oil Seal	At least once every 5000 hours	Remove Servomotor from machine and replace oil seal.	Applies only to motors with oil seals.
Overhaul	At least once every 20000 hours or 5 years	Contact your Yaskawa representative.	The user should not disassemble and clean the Servomotor.

* Measure across the Servomotor FG and the U-phase, V-phase, or W-phase power line

9.1.2 Servopack Inspection

For inspection and maintenance of the Servopack, follow the inspection procedures in the following table at least once every year. Other routine inspections are not required.

Table 9.2 Servopack Inspections

Item	Frequency	Procedure	Comments
Clean Interior and Circuit Boards	At least once a year	Check for dust, dirt, and oil on the surfaces.	Clean with compressed air.
Loose Screws	At least once a year	Check for loose terminal block and connector screws.	Tighten any loose screws.
Defective Parts in Unit or on Circuit Boards	At least once a year	Check for discoloration, damage or discontinuities due to heating.	Contact your Yaskawa representative.

■ Part Replacement Schedule

The following parts are subject to mechanical wear or deterioration over time. To avoid failure, replace these parts at the frequency indicated.

The user constants of any Servopacks overhauled by Yaskawa are reset to the standard settings before shipping. Be sure to confirm that the user constants are properly set before starting operation.

Table 9.3 Periodical Part Replacement

Part	Standard Replacement Period	Replacement Method
Cooling Fan	4 to 5 years	Replace with new part.
Smoothing Capacitor	7 to 8 years	Test. Replace with new part if necessary.
Relays	-	Test. Replace if necessary.
Fuse	10 years	Replace with new part.
Aluminum Electrolytic Capacitor on Circuit Board	5 years	Test. Replace with new circuit board if necessary.

Operating Conditions:

- Ambient Temperature: Annual average of 30°C
- Load Factor: 80% max.
- Operation Rate: 20 hours/day max.

9.1.3 Replacing Battery for Absolute Encoder

If the voltage of the battery for an absolute encoder drops to approx. 2.7 V or less, an Absolute Encoder Battery Alarm (A. 83) will occur in the Servopack. This alarm occurs when the Servopack receives a signal from the absolute encoder when the power to the Servopack is turned ON. Therefore, the Servopack will not give an alarm when the battery voltage drops below the minimum voltage level while the power is being supplied to the Servopack.

Refer to *5.7.3 Handling Batteries* for the battery type recommended for absolute encoders.

Replace the battery using the following procedure if the battery voltage drops below the minimum required battery voltage.

■ Battery Replacement Procedure

1. Replace the battery while the control power to the Servopack is ON.
2. After replacement, turn OFF the power to the Servopack in order to clear the Absolute Encoder Battery Alarm (A. 83).
3. Turn ON the power to the Servopack again and confirm that it operates properly to complete battery replacement.

IMPORTANT

The absolute encoder data will be lost when the control power to the Servopack is turned OFF and when the encoder cable is disconnected from the battery. If the data is lost, refer to *5.7.4 Initializing the Absolute Encoder* and initialize the absolute encoder.

9.2 Troubleshooting

This section describes causes and remedies for problems which cause an alarm display and for problems which result in no alarm display.

9.2.1 Troubleshooting Problems with Alarm Displays

Problems that occur in the Servodrives are displayed on the panel operator as “A.□□” or “CPF-□□”. “A.- -”, however, does not indicate an alarm. Refer to the following sections to identify the cause of an alarm and the action to be taken.

Contact your Yaskawa representative if the problem cannot be solved by the described procedures.

■ A.02

A.02: User Constants Breakdown

Display and Outputs

Alarm Outputs			
Alarm Code Outputs			ALM Output
ALO1	ALO2	ALO3	
OFF	OFF	OFF	OFF

Note OFF: Output transistor is OFF (alarm state).

Status and Remedy for Alarm

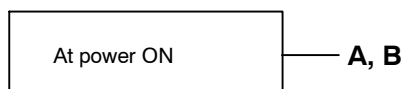

Cause		Remedy
A	Power turned OFF during parameter write. Alarm occurred at next power ON.	<ul style="list-style-type: none"> Initialize user constants using Fn005 and reinput user settings. Replace Servopack.
B	Circuit board (1PWB) defective.	Replace Servopack.

■ **A.03**

A.03: Main Circuit Detector Error

Display and Outputs

Alarm Outputs			
Alarm Code Outputs			ALM Output
ALO1	ALO2	ALO3	
OFF	OFF	OFF	OFF

Note OFF: Output transistor is OFF (alarm state).

Status and Remedy for Alarm

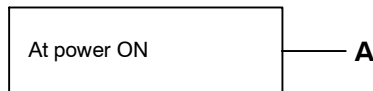

Cause		Remedy
A	Circuit board (1PWB or 2PWB) defective.	Replace Servopack.

■ **A.04**

A.04: User Constant Setting Error

Display and Outputs

Alarm Outputs			
Alarm Code Outputs			ALM Output
ALO1	ALO2	ALO3	
OFF	OFF	OFF	OFF

Note OFF: Output transistor is OFF (alarm state)

Status and Remedy for Alarm



Cause		Remedy
A	An out-of-range user constant was previously set or loaded.	<ul style="list-style-type: none"> • Reset all user constants in range. • Otherwise, re-load correct user constant.
B	Circuit board (1PWB) defective.	Replace Servopack.

■ A.05

A.05: Combination Error

Display and Outputs

Alarm Outputs			
Alarm Code Outputs			ALM Output
ALO1	ALO2	ALO3	
OFF	OFF	OFF	OFF

Note OFF: Output transistor is OFF (alarm state).

Status and Remedy for Alarm

At power ON

— A, B

Cause		Remedy
A	The range of Servomotor capacities that can be combined has been exceeded.	Replace the Servomotor so that a suitable combination is achieved.
B	Encoder parameters have not been written properly.	Replace the Servomotor.

■ **A.10**

A.10: Overcurrent or Heat Sink Overheated

Display and Outputs

Alarm Outputs			
Alarm Code Outputs			ALM Output
ALO1	ALO2	ALO3	
ON	OFF	OFF	OFF

Note OFF: Output transistor is OFF (alarm state). ON: Output transistor is ON.

Status and Remedy for Alarm



Cause		Remedy
A	Wiring shorted between Servopack and Servomotor.	Check and correct wiring.
B	Servomotor U, V, or W phase shorted.	Replace Servomotor.
C	<ul style="list-style-type: none"> • Circuit board (1PWB) defective. • Power transistor defective. 	Replace Servopack.
D	Current feedback circuit, power transistor, DB circuit, or circuit board defective.	Replace Servopack.
E	The ambient temperature of the Servopack exceeded 55°C.	Alter conditions so that the ambient temperature goes below 55°C.
F	The air flow around the heat sink is bad.	Follow the installation method and provide sufficient space as specified.
G	Fan stopped.	Replace Servopack.
H	Servopack is operating under an overload.	Reduce load.

Note E to H can occur with a Servopack with a capacity of all models (400 V) and 1.5 kW to 5 kW (200 V).

■ A.30

A.30: Regenerative Error Detected

Display and Outputs

Alarm Outputs			
Alarm Code Outputs			ALM Output
ALO1	ALO2	ALO3	
ON	ON	OFF	OFF

Note OFF: Output transistor is OFF (alarm state). ON: Output transistor is ON.

Status and Remedy for Alarm

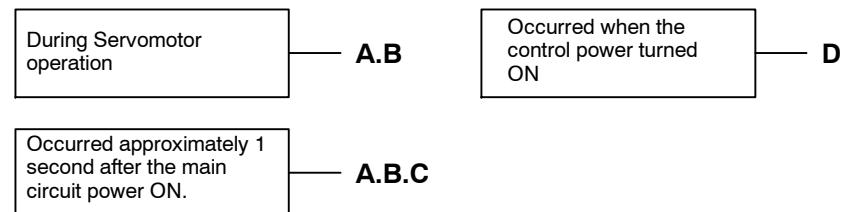

Cause		Remedy
A	Regenerative transistor is abnormal.	Replace Servopack.
B	Disconnection of the regenerative resistor.	Replace Servopack or regenerative resistor.
C	Regenerative Unit disconnected (for an external regenerative resistor).	Check wiring of the external regenerative resistor.
D	Servopack defective.	Replace Servopack.

■ **A.32**

A.32: Regenerative Overload

Display and Outputs

Alarm Outputs			
Alarm Code Outputs			ALM Output
ALO1	ALO2	ALO3	
ON	ON	OFF	OFF

Note OFF: Output transistor is OFF (alarm state). ON: Output transistor is ON.

Status and Remedy for Alarm

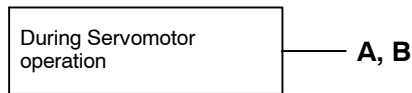

Cause		Remedy
A	Regenerative power exceeds the allowable value.	Use an external regenerative resistor that matches the regenerative power capacity.
B	Alarm occurs although an external regenerative resistor is used and the temperature rise of the regenerative resistor is small.	Correct user constant Pn600.

■ A.40

A.40: Main Circuit DC Voltage Error Detected: Overvoltage

Display and Outputs

Alarm Outputs			
Alarm Code Outputs			ALM Output
ALO1	ALO2	ALO3	
OFF	OFF	ON	OFF

Note OFF: Output transistor is OFF (alarm state). ON: Output transistor is ON.

Status and Remedy for Alarm

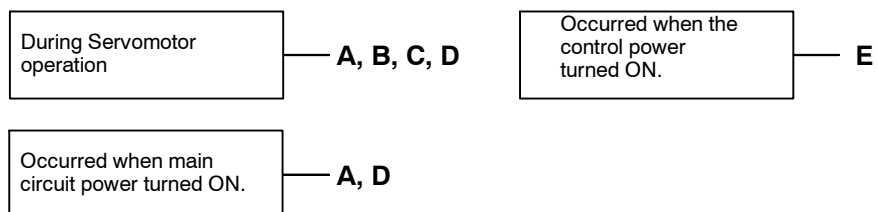

Cause		Remedy
A	The power supply voltage is not within the range of specifications.	Check power supply.
B	Load exceeds capacity of the Regenerative Unit.	Check specifications of load inertia and overhanging load.
C	Regenerative transistor is abnormal.	Replace Servopack.
D	Rectifying diode defective.	
E	Servopack defective.	

■ **A.41**

A.41: Main Circuit DC Voltage Error Detected: Undervoltage

Display and Outputs

Alarm Outputs			
Alarm Code Outputs			ALM Output
ALO1	ALO2	ALO3	
OFF	OFF	ON	OFF

Note OFF: Output transistor is OFF (alarm state). ON: Output transistor is ON.

Status and Remedy for Alarm

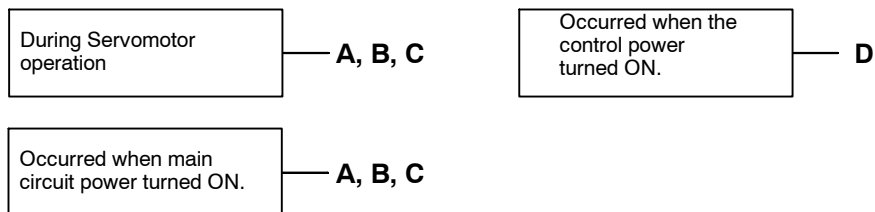

Cause		Remedy
A	The power supply voltage is not within the range of specifications.	Check power supply voltage.
B	Fuse blown.	Replace Servopack.
C	Rectifying diode defective.	
D	Servopack defective.	

■ A.51

A.51: Overspeed

Display and Outputs

Alarm Outputs			
Alarm Code Outputs			ALM Output
ALO1	ALO2	ALO3	
ON	OFF	ON	OFF

Note OFF: Output transistor is OFF (alarm state). ON: Output transistor is ON.

Status and Remedy for Alarm

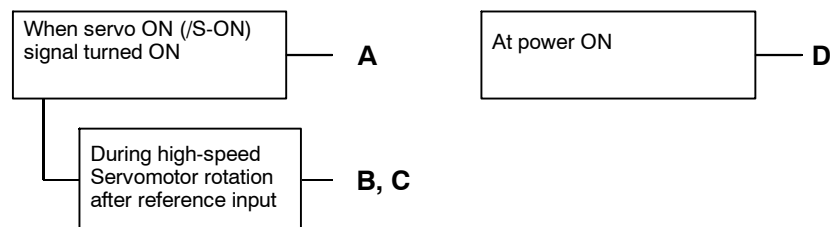

Cause		Remedy
A	Servomotor wiring incorrect.	Check and correct wiring. (Check for U-, V-, and W-phase wiring errors.)
B	Position or speed reference input is too large.	Lower the reference input values.
C	Incorrect reference input gain settings.	Check and correct user constant settings.
D	Circuit board (1PWB) defective.	Replace Servopack.

■ **A.71**

A.71: Overload: High Load

The alarm output, status, and remedy for A.71 are the same as for A.72.

■ **A.72**

A.72: Overload: Low Load

Display and Outputs

Alarm Outputs			
Alarm Code Outputs			ALM Output
ALO1	ALO2	ALO3	
ON	ON	ON	OFF

Note OFF: Output transistor is OFF (alarm state). ON: Output transistor is ON.

Status and Remedy for Alarm

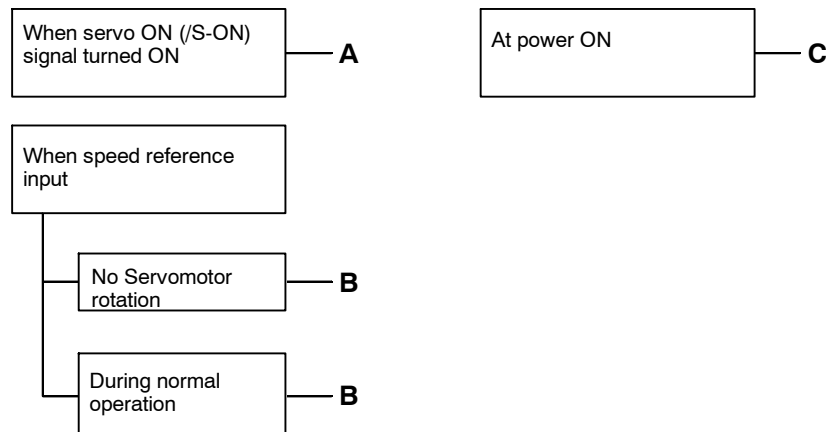

	Cause	Remedy
A	Servomotor wiring incorrect or disconnected.	Check wiring and connectors at Servomotor.
B	Load greatly exceeds rated torque.	Reduce load torque and inertia. Otherwise, replace with larger capacity Servomotor.
C	Circuit board (1PWB) defective.	Replace Servopack.

■ A.73

A.73: Dynamic Brake Overload

Display and Outputs

Alarm Outputs			
Alarm Code Outputs			ALM Output
ALO1	ALO2	ALO3	
ON	ON	ON	OFF

Note OFF: Output transistor is OFF (alarm state). ON: Output transistor is ON.

Status and Remedy for Alarm



	Cause	Remedy
A	The product of the square of rotational motor speed and the combined inertia of the motor and load (rotation energy) exceeds the capacity of the dynamic brake resistor built into Servopack.	<ul style="list-style-type: none"> • Lower the rotational speed. • Lower the load inertia. • Minimize the use of the dynamic brake.
B	Circuit board (1PWB) defective.	Replace Servopack.

■ A.74

A.74: Overload of Surge Current Limit Resistor

Display and Outputs

Alarm Outputs			
Alarm Code Outputs			ALM Output
ALO1	ALO2	ALO3	
ON	ON	ON	OFF

Note OFF: Output transistor is OFF (alarm state). ON: Output transistor is ON.

Status and Remedy for Alarm



	Cause	Remedy
A	Frequently turning the main circuit power ON/OFF.	Do not repeatedly turn ON/OFF the main circuit power.
B	Circuit board (1PWB) defective.	Replace Servopack.

■ **A.7A**

A.7A: Heat Sink Overheated

Display and Outputs

Alarm Outputs			
Alarm Code Outputs			ALM Output
ALO1	ALO2	ALO3	
ON	ON	ON	OFF

Note OFF: Output transistor is OFF (alarm state). ON: Output transistor is ON.

Status and Remedy for Alarm

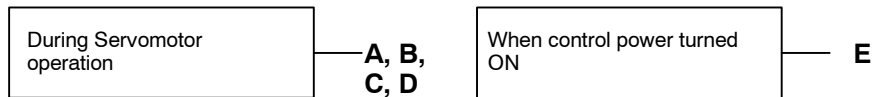

Cause		Remedy
A	The ambient temperature of the Servopack exceeds 55°C.	Alter conditions so that the ambient temperature goes below 55°C.
B	The air flow around the heat sink is bad.	Follow installation methods and provide sufficient space as specified.
C	Fan stopped.	Replace Servopack.
D	Servopack is operating under overload.	Reduce load.
E	Servopack defective	Replace Servopack.

Note This alarm display tends to occur only with a Servopack of 30 W to 1000 W.

■ A.81

A.81: Absolute Encoder Backup Error

Display and Outputs

Alarm Outputs			
Alarm Code Outputs			ALM Output
ALO1	ALO2	ALO3	
OFF	OFF	OFF	OFF

Note OFF: Output transistor is OFF (alarm state).

Status and Remedy for Alarm

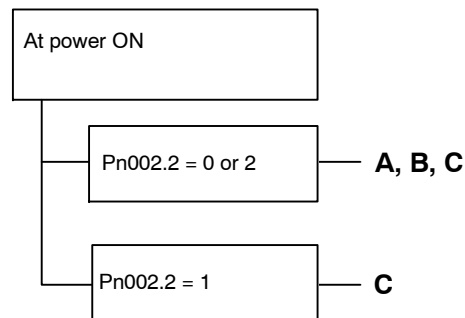

Cause		Remedy
A	The following power supplies to the absolute encoder all failed: <ul style="list-style-type: none"> • +5 V supply • Battery power 	Follow absolute encoder set-up procedure.
B	Absolute encoder malfunctioned.	Replace Servomotor.
C	Circuit board (1PWB) defective.	Replace Servopack.

■ **A.82**

A.82: Encoder Checksum Error

Display and Outputs

Alarm Outputs			
Alarm Code Outputs			ALM Output
ALO1	ALO2	ALO3	
OFF	OFF	OFF	OFF

Note OFF: Output transistor is OFF (alarm state).

Status and Remedy for Alarm

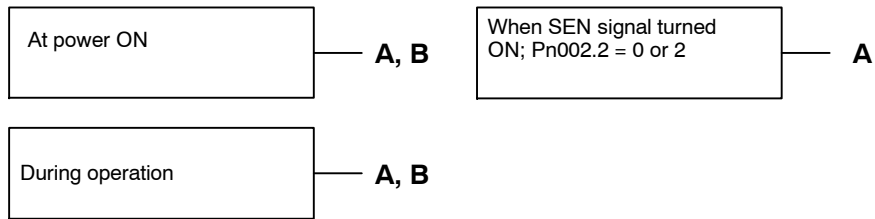

Cause		Remedy
A	Error during encoder memory check	<ul style="list-style-type: none"> Follow absolute encoder set-up procedure. Replace Servomotor if error occurs frequently.
B	Circuit board (1PWB) defective.	Replace Servopack.

■ A.83

A.83: Absolute Encoder Battery Error

Display and Outputs

Alarm Outputs			
Alarm Code Outputs			ALM Output
ALO1	ALO2	ALO3	
OFF	OFF	OFF	OFF

Note OFF: Output transistor is OFF (alarm state).

Status and Remedy for Alarm

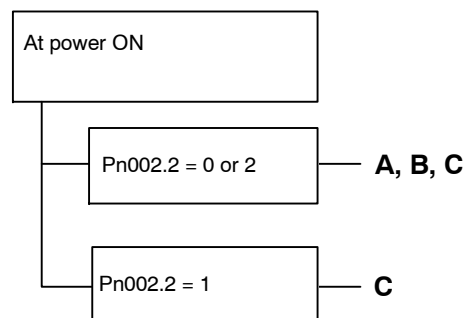

Cause		Remedy
A	<ul style="list-style-type: none"> Battery not connected Battery connection defective 	Check and correct battery connection.
B	Battery voltage below specified value. Specified value: 2.7 V.	Install a new battery while the control power to Servopack is ON. After replacement, turn ON the power again.
C	Circuit board (1PWB) defective.	Replace Servopack.

Note No alarm will occur at the Servopack is the battery error occurs during operation.

■ **A.84**

A.84: Absolute Encoder Data Error

Display and Outputs

Alarm Outputs			
Alarm Code Outputs			ALM Output
ALO1	ALO2	ALO3	
OFF	OFF	OFF	OFF

Note OFF: Output transistor is OFF (alarm state).

Status and Remedy for Alarm



Cause		Remedy
A	Faulty encoder.	Replace the Servomotor is the problem occurs often.
B	Operational error in encoder caused by external noise.	Check and correct wiring around the encoder (grounding of the Servomotor, separation between the encoder cable and the servomotor power cable, insertion of toroidal cores onto cables, etc.).

■ A.85

A.85: Absolute Encoder Overspeed

Display and Outputs

Alarm Outputs			
Alarm Code Outputs			ALM Output
ALO1	ALO2	ALO3	
OFF	OFF	OFF	OFF

Note OFF: Output transistor is OFF (alarm state).

Status and Remedy for Alarm



Cause		Remedy
A	Absolute encoder turned ON at a speed exceeding 200 r/min.	Turn ON power supply with the Servomotor stopped.
B	Circuit board (1PWB) defective.	Replace Servopack.

■ A.86

A.86: Encoder Overheated

Display and Outputs

Alarm Outputs			
Alarm Code Outputs			ALM Output
ALO1	ALO2	ALO3	
OFF	OFF	OFF	OFF

Note OFF: Output transistor is OFF (alarm state).

Status and Remedy for Alarm



Cause		Remedy
A	The ambient temperature of the Servomotor is high.	Alter conditions so that the ambient temperature goes below 40°C
B	Servomotor is operating under overload.	Reduce load.
C	Circuit board (1PWB) defective.	Replace Servopack.
D	Encoder defective.	Replace Servopack.

■ **A.b1**

A.b1: Reference Speed Input Read Error

Display and Outputs

Alarm Outputs			
Alarm Code Outputs			ALM Output
ALO1	ALO2	ALO3	
OFF	OFF	OFF	OFF

Note OFF: Output transistor is OFF (alarm state).

Status and Remedy for Alarm



Cause		Remedy
A	Error in reference read-in unit (A/D Converter, etc.).	Reset alarm and restart operation.
B	Reference read-in unit faulty (A/D Converter, etc.).	Replace Servopack.
C	Circuit board (1PWB) defective.	Replace Servopack.

■ **A.b2**

A.b2: Reference Torque Input Read Error

Display and Outputs

Alarm Outputs			
Alarm Code Outputs			ALM Output
ALO1	ALO2	ALO3	
OFF	OFF	OFF	OFF

Note OFF: Output transistor is OFF (alarm state).

Status and Remedy for Alarm



Cause		Remedy
A	Error in reference read-in unit (A/D Converter, etc.).	Reset alarm and restart operation.
B	Reference read-in unit faulty (A/D Converter, etc.).	Replace Servopack.
C	Circuit board (1PWB) defective.	Replace Servopack.

■ A.C1

A.C1: Servo Overrun

Display and Outputs

Alarm Outputs			
Alarm Code Outputs			ALM Output
ALO1	ALO2	ALO3	
ON	OFF	ON	OFF

Note OFF: Output transistor is OFF (alarm state). ON: Output transistor is ON.

Status and Remedy for Alarm

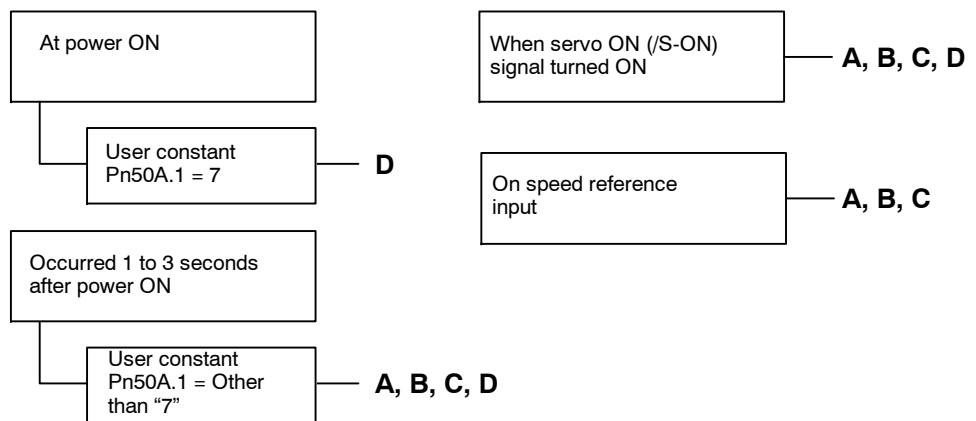

Cause		Remedy
A	Servomotor wiring incorrect or disconnected.	Check wiring and connectors at Servomotor.
B	Encoder wiring incorrect or disconnected.	Check wiring and connectors at encoder.
C	Encoder defective.	Replace Servomotor.
D	Circuit board (1PWB) defective.	Replace Servopack.

■ **A.C8**

A.C8: Absolute Encoder Clear Error and Multi-turn Limit Setting Error

Display and Outputs

Alarm Outputs			
Alarm Code Outputs			ALM Output
ALO1	ALO2	ALO3	
ON	OFF	ON	OFF

Note OFF: Output transistor is OFF (alarm state). ON: Output transistor is ON.

Status and Remedy for Alarm

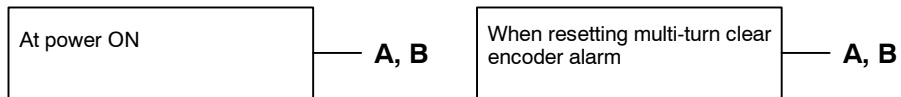

Cause		Remedy
A	Encoder defective.	Replace Servomotor.
B	Servopack defective.	Replace Servopack.

■ **A.C9**

A.C9: Encoder Communications Error

Display and Outputs

Alarm Outputs			
Alarm Code Outputs			ALM Output
ALO1	ALO2	ALO3	
ON	OFF	ON	OFF

Note OFF: Output transistor is OFF (alarm state). ON: Output transistor is ON.

Status and Remedy for Alarm

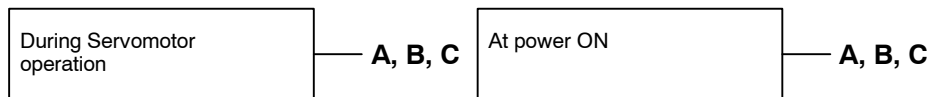

Cause		Remedy
A	Encoder wiring incorrect or disconnected	Check wiring and connectors at encoder.
B	Encoder defective.	Replace Servomotor.
C	Servopack defective.	Replace Servopack.

■ A.CA

A.CA: Encoder Parameter Error

Display and Outputs

Alarm Outputs			
Alarm Code Outputs			ALM Output
ALO1	ALO2	ALO3	
ON	OFF	ON	OFF

Note OFF: Output transistor is OFF (alarm state). ON: Output transistor is ON.

Status and Remedy for Alarm



Cause		Remedy
A	Encoder defective.	Replace Servomotor.
B	Servopack defective.	Replace Servopack.

■ A.Cb

A.Cb: Encoder Echoback Error

Display and Outputs

Alarm Outputs			
Alarm Code Outputs			ALM Output
ALO1	ALO2	ALO3	
ON	OFF	ON	OFF

Note OFF: Output transistor is OFF (alarm state). ON: Output transistor is ON.

Status and Remedy for Alarm



Cause		Remedy
A	Encoder wiring incorrect or disconnected.	Check wiring and connectors at encoder.
B	Encoder defective.	Replace Servomotor.
C	Servopack defective.	Replace Servopack.

■ **A.CC**

A.CC: Multiturn Limit Disagreement Alarm

Display and Outputs

Alarm Outputs			
Alarm Code Outputs			ALM Output
ALO1	ALO2	ALO3	
ON	OFF	ON	OFF

Note OFF: Output transistor is OFF (alarm state). ON: Output transistor is ON.

Status and Remedy for Alarm



Cause		Remedy
A	The setting of the Multiturn Limit Setting (Pn205) user constant in the Servopack is incorrect.	Change use constant Pn205.
B	The multiturn limit has not been set in the encoder.	Check to be sure the Multiturn Limit Setting (Pn205) user constant in the Servopack is correct, create a Multiturn Limit Disagreement Alarm (A.CC), and then execute the encoder multiturn limit setting change (Fn013).

■ A.d0

A.d0: Position Error Pulse Overflow

Display and Outputs

Alarm Outputs			
Alarm Code Outputs			ALM Output
ALO1	ALO2	ALO3	
ON	ON	OFF	OFF

Note OFF: Output transistor is OFF (alarm state). ON: Output transistor is ON.

Status and Remedy for Alarm

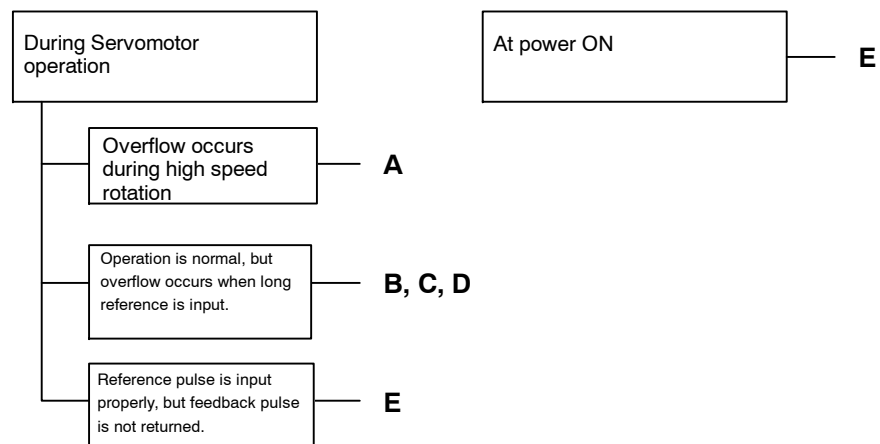

	Cause	Remedy
A	Servomotor wiring incorrect or poor connection	Check wiring and connectors at encoder.
B	Servopack was not correctly adjusted.	Increase speed loop gain (Pn100) and position loop gain (Pn102).
C	Motor load was excessive.	Reduce load torque or inertia. If problem not corrected, replace with a motor with larger capacity.
D	Position reference pulse frequency was too high.	<ul style="list-style-type: none"> • Increase or decrease reference pulse frequency. • Add smoothing function. • Correct electronic gear ratio.
E	Circuit board (1PWB) defective.	Replace Servopack.

■ **A.E7**

A.E7: Option Unit Detection Error

A.E7 occurs when the SGDh is used without option unit after it has been used with option unit.

This alarm can not be cleared by alarm reset. Clear the alarm by Fn014 (option unit detection result clear) of auxiliary function mode.

Display and Outputs

Alarm Outputs			
Alarm Code Outputs			ALM Output
ALO1	ALO2	ALO3	
ON	ON	OFF	OFF

Note OFF: Output transistor is OFF (alarm state). ON: Output transistor is ON.

Status and Remedy for Alarm

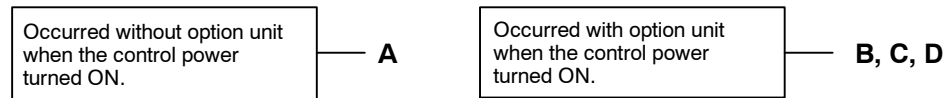

Cause		Remedy
A	The SGDh is used without option unit after it has been used with option unit.	To continue using the SGDh without option unit, execute Fn014 (option unit detection result clear) of the auxiliary function mode and restart the power.
B	Option unit connection defective.	Check and correct the connection.
C	Option unit defective.	Replace option unit.
D	Connector Cn10 of Servopack defective.	Replace Servopack.

■ A.F1

A.F1: Power Line Open Phase

Display and Outputs

Alarm Outputs			
Alarm Code Outputs			ALM Output
ALO1	ALO2	ALO3	
OFF	ON	OFF	OFF

Note OFF: Output transistor is OFF (alarm state). ON: Output transistor is ON.

Status and Remedy for Alarm

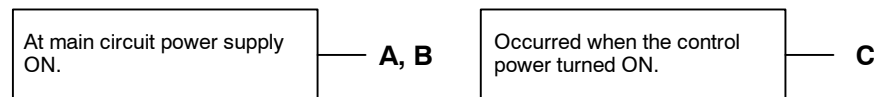

Cause		Remedy
A	One phase (L1, L2, or L3) of the main circuit power supply is disconnected.	<ul style="list-style-type: none"> • Check power supply. • Check wiring of the main circuit power supply. • Check QF, noise filter, magnetic contactor.
B	There is one phase where the line voltage is low.	Check power supply.
C	Servopack defective.	Replace Servopack.

Note A and B tend to occur in a Servopack with a capacity of 500 W or higher.

■ **CPF00**

CPF00: Digital Operator Transmission Error 1

This alarm is not stored in the alarm trace-back function memory.

Display and Outputs

Alarm Outputs			
Alarm Code Outputs			ALM Output
ALO1	ALO2	ALO3	
Not specified			

Status and Remedy for Alarm

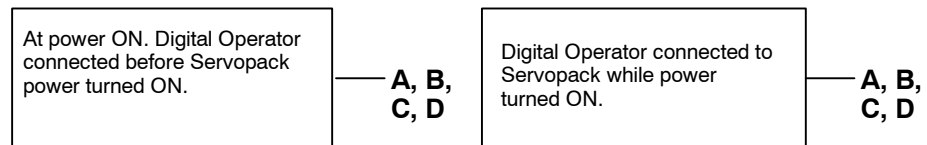

Cause		Remedy
A	Cable defective or poor contact between Digital Operator and Servopack.	<ul style="list-style-type: none"> • Check connector connections. • Replace cable.
B	Malfunction due to external noise.	Separate Digital Operator and cable from noise source.
C	Digital Operator defective.	Replace Digital Operator.
D	Servopack defective.	Replace Servopack.

■ CPF01

CPF01: Digital Operator Transmission Error 2

This alarm is not stored in the alarm trace-back function memory.

Display and Outputs

Alarm Outputs			
Alarm Code Outputs			ALM Output
ALO1	ALO2	ALO3	
Not specified			

Status and Remedy for Alarm

During operation

A, B, C, D

Cause		Remedy
A	Cable defective or poor contact between Digital Operator and Servopack.	<ul style="list-style-type: none"> • Check connector connections. • Replace cable.
B	Malfunction due to external noise	Separate Digital Operator and cable from noise source.
C	Digital Operator defective.	Replace Digital Operator.
D	Servopack defective.	Replace Servopack.

■ A.- -

A.- -: Normal Operation

This is not an alarm display.

Display and Outputs

Alarm Outputs			
Alarm Code Outputs			ALM Output
ALO1	ALO2	ALO3	
OFF	OFF	OFF	ON

Note OFF: Output transistor is OFF (alarm state). ON: Output transistor is ON.

9.2.2 Troubleshooting Problems with No Alarm Display

Refer to the tables below to identify the cause of a problem which causes no alarm display and take the remedy described.

Turn OFF the servo system power supply before commencing the shaded procedures.

Contact your Yaskawa representative if the problem cannot be solved by the described procedures.

Table 9.4 Troubleshooting Table No Alarm Display

Symptom	Cause	Inspection	Remedy
Servomotor Does Not Start	Power not connected	Check voltage between power supply terminals.	Correct the power circuit.
	Loose connection	Check terminals of connectors (CN1, CN2).	Tighten any loose parts.
	Connector (CN1) external wiring incorrect	Check connector (CN1) external wiring	Refer to connection diagram and correct wiring.
	Servomotor or encoder wiring disconnected.	---	Reconnect wiring
	Overloaded	Run under no load.	Reduce load or replace with larger capacity Servomotor.
	Speed/position references not input	Check reference input pins.	Correctly input speed/position references.
	/S-ON is turned OFF	Check settings of user constants Pn50A.0 and Pn50A.1.	Turn /S-ON input ON.
	/P-CON input function setting incorrect	Check user constant Pn000.1.	Refer to section 5.3.5 and set user constants to match application.
	Reference pulse mode selection incorrect.	Refer to section 5.2.2	Correct setting of user constant Pn200.0.
	Encoder type differs from user constant setting.	Incremental or absolute encoder?	Set user constant Pn002.2 to the encoder type being used.
	P-OT and N-OT inputs are turned OFF.	Refer to section 5.1.2.	Turn P-OT and N-OT input signals ON.
	CLR input is turned ON	Check status of error counter clear input.	Turn CLR input OFF.
SEN input is turned OFF.	When absolute encoder is used.	Turn SEN input ON.	
Servomotor Moves Instantaneously, then Stops	Servomotor or encoder wiring incorrect.	---	Refer to chapter 3 and correct wiring.
Suddenly Stops during Operation and will Not Restart	Alarm reset signal (/ALM-RST) is turned ON because an alarm occurred	---	Remove cause of alarm. Turn alarm reset signal (ALM-RST) from ON to OFF.

Symptom	Cause	Inspection	Remedy
Servomotor Speed Unstable	Wiring connection to motor defective	Check connection of power lead (U, V, and W phases) and encoder connectors.	Tighten any loose terminals or connectors.
Servomotor Vibrates at Approximately 200 to 400 Hz.	Speed loop gain value too high.	---	Reduce speed loop gain (Pn100) preset value.
	Speed/position reference input lead too long.	---	Minimize length of speed/position reference input lead, with impedance not exceeding several hundred ohms
	Speed/position reference input lead is bundled with power cables.	---	Separate reference input lead at least 30 cm from power cables.
High Rotation Speed Overshoot on Starting and Stopping.	Speed loop gain value too high.	---	Reduce speed loop gain (Pn100) preset value. Increase integration time constant (Pn101).
	Speed loop gain is too low compared to position loop gain.	---	Increase the value of user constant Pn100 (speed loop gain). Reduce the integration time constant (Pn101).
Servomotor Overheated	Ambient temperature too high	Measure Servomotor ambient temperature.	Reduce ambient temperature to 40°C max.
	Servomotor surface dirty	Visual check	Clean dust and oil from motor surface.
	Overloaded	Run under no load.	Reduce load or replace with larger capacity Servomotor.
Abnormal Noise	Mechanical mounting incorrect	Servomotor mounting screws loose?	Tighten mounting screws.
		Coupling not centered?	Center coupling.
		Coupling unbalanced?	Balance coupling.
	Bearing defective	Check noise and vibration near bearing.	Consult your Yaskawa representative if defective.
Machine causing vibrations	Foreign object intrusion, damage or deformation of sliding parts of machine.	Consult with machine manufacturer.	
Speed Reference 0 V but Servomotor Rotates.	Speed reference voltage offset applied	---	Adjust reference offset. Refer to sections 7.2.4 and 7.2.5

9.2.3 Alarm Display Table

A summary of alarm displays and alarm code outputs is given in the following table.

Table 9.5 Alarm Display Table

Alarm Display	Alarm Code Outputs			ALM Output	Alarm Name	Meaning
	ALO1	ALO2	ALO3			
A.02	OFF	OFF	OFF	OFF	User Constant Breakdown ^{*2}	EEPROM data of Servopack is abnormal.
A.03					Main Circuit Encoder Error	Detection data for power circuit is abnormal.
A.04					User Constant Setting Error ^{*2}	The user constant setting is outside the allowable setting range.
A.05					Combination Error	Servopack and Servomotor capacities do not match each other.
A.10	ON	OFF	OFF	OFF	Overcurrent or Heat Sink Overheated ^{*2}	An overcurrent flowed through the IGBT. Heat sink of Servopack was overheated.
A.30	ON	ON	OFF	OFF	Regeneration Error Detected	<ul style="list-style-type: none"> Regenerative circuit is faulty Regenerative resistor is faulty.
A.32					Regenerative Overload	Regenerative energy exceeds regenerative resistor capacity.
A.40	OFF	OFF	ON	OFF	Overvoltage ^{*4}	Main circuit DC voltage is excessively high.
A.41					Undervoltage ^{*4}	Main circuit DC voltage is excessively low.
A.51	ON	OFF	ON	OFF	Overspeed	Rotational speed of the motor is excessively high.
A.71	ON	ON	ON	OFF	Overload: High Load	The motor was operating for several seconds to several tens of seconds under a torque largely exceeding ratings.
A.72					Overload: Low Load	The motor was operating continuously under a torque largely exceeding ratings
A.73					Dynamic Brake Overload	When the dynamic brake was applied, rotational energy exceeded the capacity of dynamic brake resistor.
A.74					Overload of Surge Current Limit Resistor	The main circuit power was frequently turned ON and OFF.
A.7A					Heat Sink Overheated ^{*1}	The heat sink of Servopack overheated.

Alarm Display	Alarm Code Outputs			ALM Output	Alarm Name	Meaning
	ALO1	ALO2	ALO3			
A.81	OFF	OFF	OFF	OFF	Encoder Backup Error* ²	All the power supplies for the absolute encoder have failed and position data was cleared.
A.82					Encoder Checksum Error* ²	The checksum results of encoder memory is abnormal.
A.83					Absolute Encoder Battery Error	Battery voltage for the absolute encoder has dropped.
A.84					Encoder Data Error* ²	Data in the encoder is abnormal.
A.85					Encoder Overspeed	The encoder was rotating at high speed when the power was turned ON.
A.86					Encoder Overheated	The internal temperature of encoder is too high.
A.b1					Reference Speed Input Read Error	The A/D converter for reference speed input is faulty.
A.b2					Reference Torque Input Read Error	The A/D converter for reference torque input is faulty.
A.bF					System Alarm* ²	A system error occurred in the Servopack.
A.C1	ON	OFF	ON	OFF	Servo Overrun Detected	The Servomotor ran out of control.
A.C8					Absolute Encoder Clear Error and Multi-turn Limit Setting Error* ²	The multi-turn for the absolute encoder was not properly cleared or set.
A.C9					Encoder Communications Error* ²	Communications between Servopack and encoder is not possible.
A.CA					Encoder Parameter Error* ²	Encoder parameters are faulty.
A.Cb					Encoder Echoback Error* ²	Contents of communications with encoder is incorrect.
A.CC					Multiturn Limit Disagreement* ³	Different multiturn limits have been set in the encoder and Servopack.
A.d0	ON	ON	OFF	OFF	Position Error Pulse Overflow	Position error pulse exceeded user constant (Pn505).
A.E7	OFF	ON	ON	OFF	Option Unit Detection Error	Option unit detection fails.
A.F1	OFF	ON	OFF	OFF	Power Line Open Phase	One phase is not connected in the main power supply
CPF00	Not specified				Digital Operator Transmission Error	Digital Operator (JUSP-OP02A-2) fails to communicate with Servopack (e.g., CPU error).
CPF01						
A. - -	OFF	OFF	OFF	ON	Not an error	Normal operation status

Note OFF: Output transistor is OFF (high).
 ON: Output transistor is ON (low).

- * 1. This alarm display appears only within the range of 30 W to 1000 W.
- * 2. These alarms are not reset for the alarm reset signal (/ALM-RST). Eliminate the cause of the alarm and then turn OFF the power supply to reset the alarms.
- * 3. This alarm will occur for the new version (SGDM-□DA) only.
- * 4. For the Servopack with a capacity of 6.0 kW or higher, alarm 40 indicates main circuit DC voltage is excessively high or low.

9.2.4 Warning Displays

The relation between warning displays and warning code outputs are shown in the following table.

Table 9.6 Warning Displays and Outputs

Warning Display	Warning Code Outputs			Warning Name	Meaning of Warning
	ALO1	ALO2	ALO3		
A.91	ON	OFF	OFF	Overload	This warning occurs before the overload alarms (A.71 or A.72) occur. If the warning is ignored and operation continues, an overload alarm may occur.
A.92	OFF	ON	OFF	Regenerative Overload	This warning occurs before the regenerative overload alarm (A.32) occurs. If the warning is ignored and operation continues, a regenerative overload alarm may occur.

Note OFF: Output transistor is OFF (high). ON: Output transistor is ON (low).

A

Host Controller Connection Examples

This appendix provides examples of connecting SGD Servopacks to typical host controllers. Refer to the manuals for the host controller when actually connecting to them.

A.1	Connecting the GL-series MC20 Motion Module	A - 2
A.2	Connecting the CP-9200SH Servo Controller Module (SVA)	A - 3
A.3	Connecting the GL-series B2813 Positioning Module	A - 4
A.4	Connecting OMRON's C500-NC221 Position Control Unit	A - 5
A.5	Connecting OMRON's C500-NC112 Position Control Unit	A - 6
A.6	Connecting MITSUBISHI's AD72 Positioning Unit	A - 7
A.7	Connecting MITSUBISHI's AD75 Positioning Unit	A - 8

A.1 Connecting the GL-series MC20 Motion Module

The following diagram shows an example of connecting to the GL-series MC20 Motion Module. In this example, the Servopack is used in Speed Control Mode.

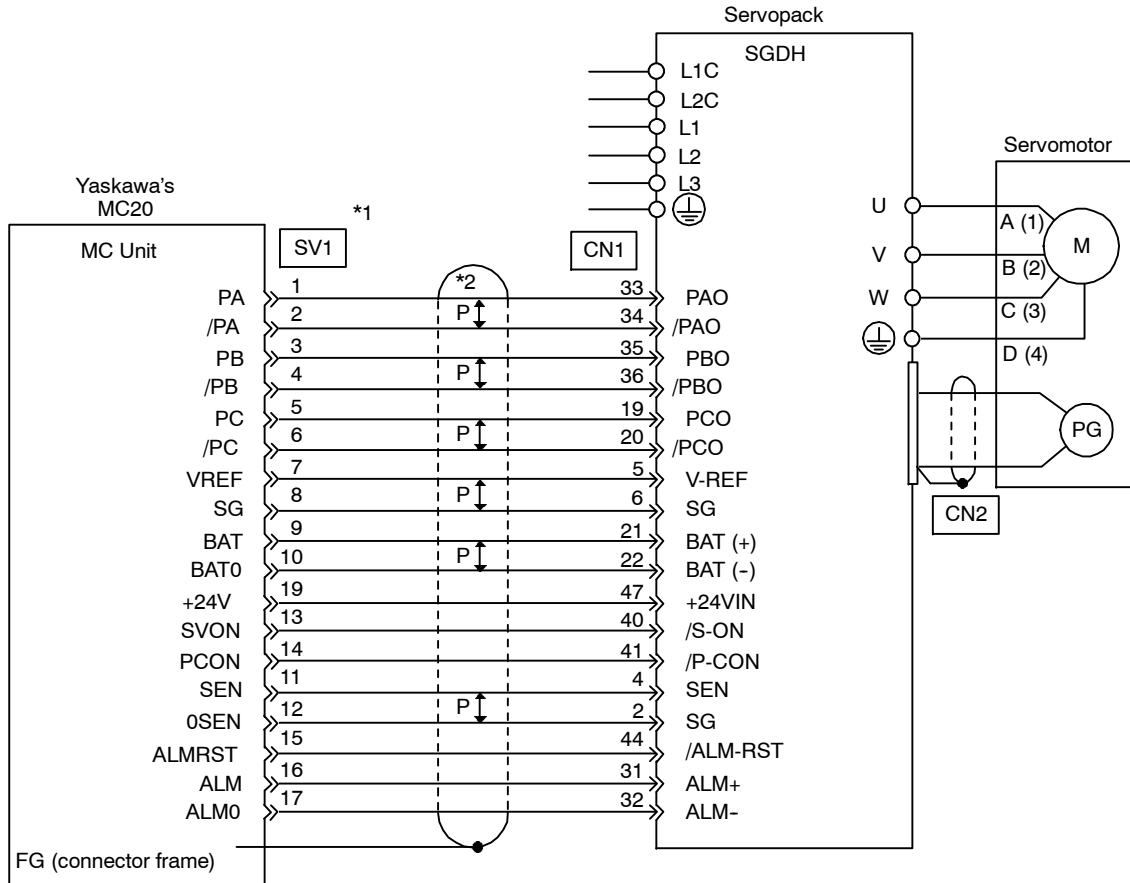

* 1. These pin numbers are the same for SV2 to SV4.

* 2. \updownarrow P indicates twisted-pair wires.

A.2 Connecting the CP-9200SH Servo Controller Module (SVA)

The following diagram shows an example of connecting to the CP-9200SH Servo Controller Module (SVA). In this example, the Servopack is used in Speed Control Mode.

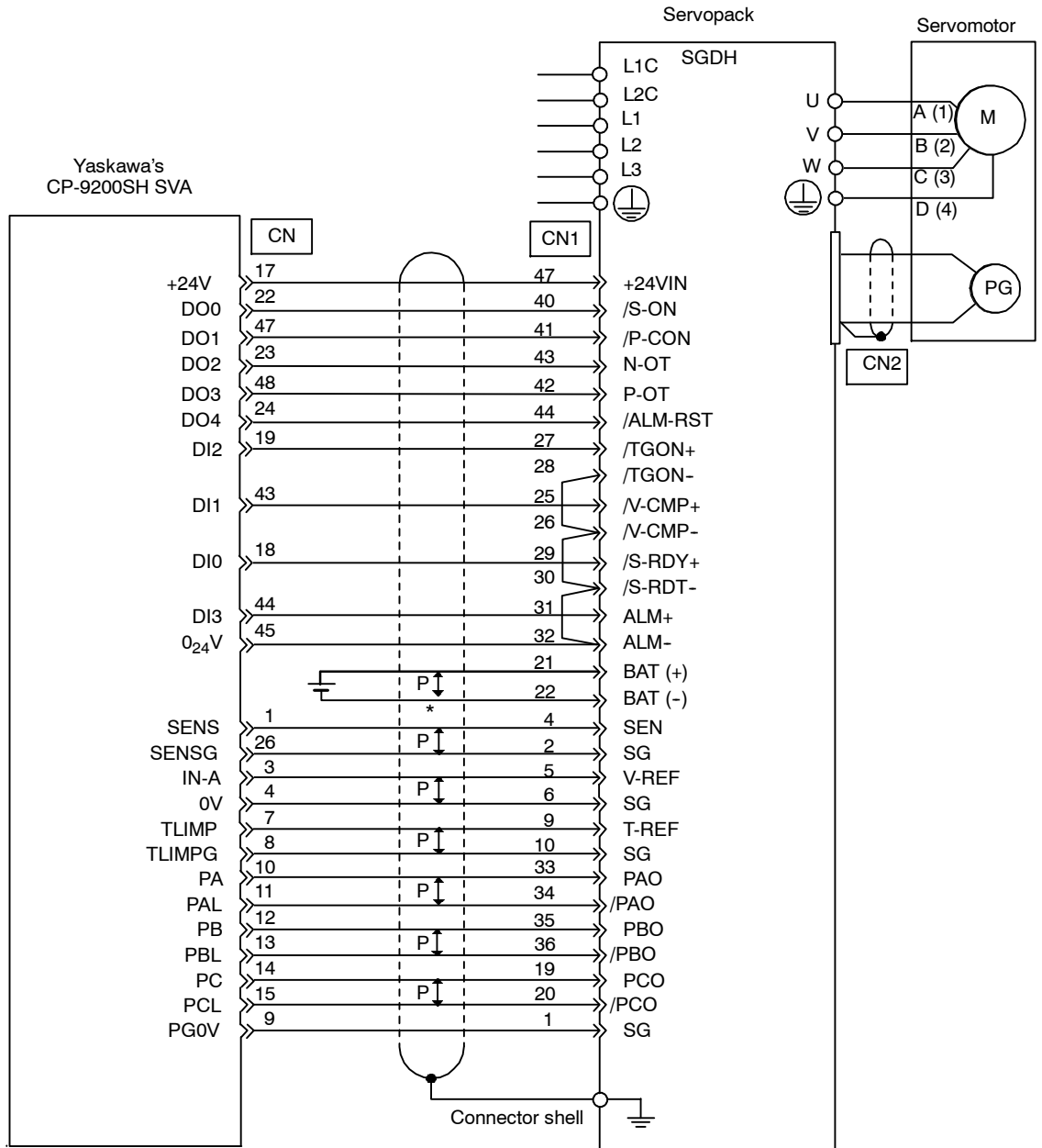

* ↑ P indicates twisted-pair wires.

A.3 Connecting the GL-series B2813 Positioning Module

The following diagram shows an example of connecting to the GL-series B2813 Positioning Module. In this example, the Servopack is used in Position Control Mode.

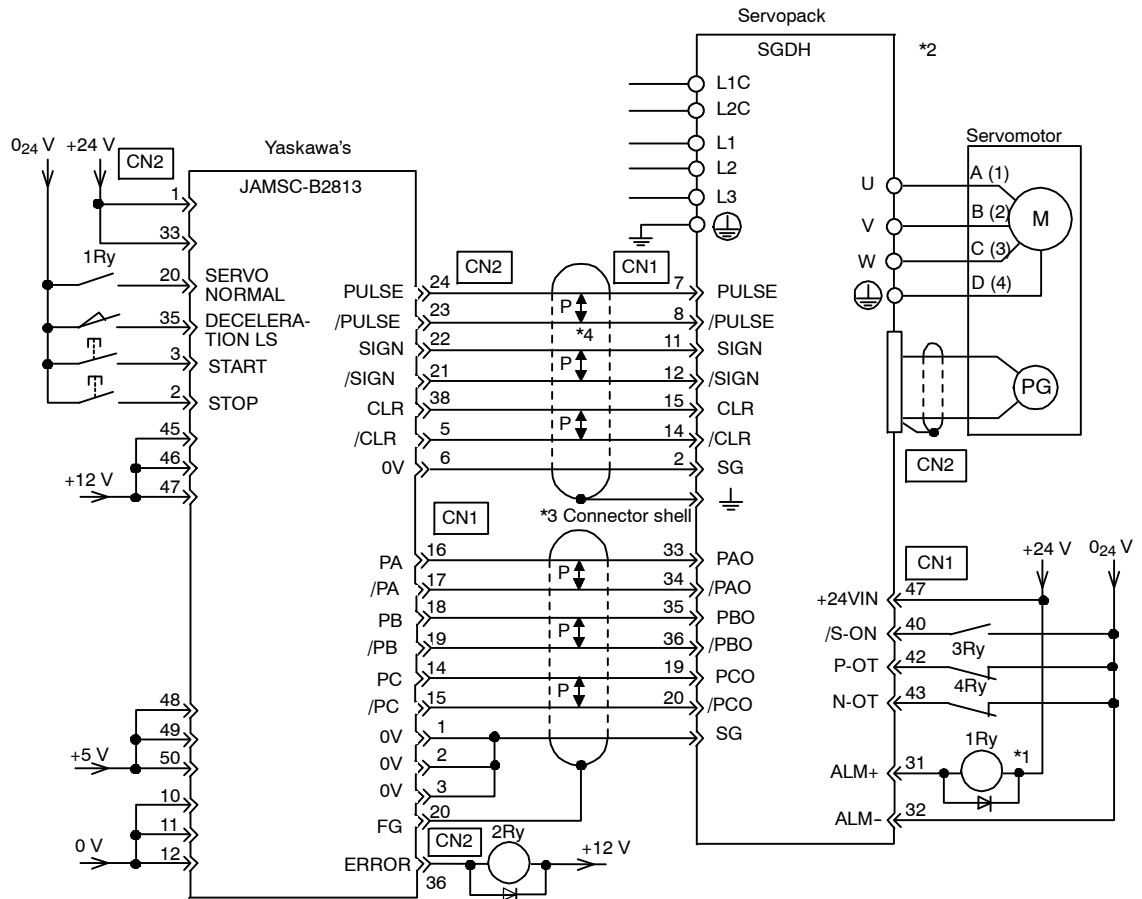

- * 1. The ALM signal is output for approximately two seconds when the power is turned ON. Take this into consideration when designing the power ON sequence. The ALM signal actuates the alarm detection relay 1Ry to stop main circuit power supply to the Servopack.
- * 2. Set user constant Pn200.0 to "1".
- * 3. Connect the shield wire to the connector shell.
- * 4. ⤴ indicates twisted-pair wires.

A.4 Connecting OMRON's C500-NC221 Position Control Unit

The following diagram shows an example of connecting to an OMRON C500-NC221 Position Control Unit. In this example, the Servopack is used in Speed Control Mode.

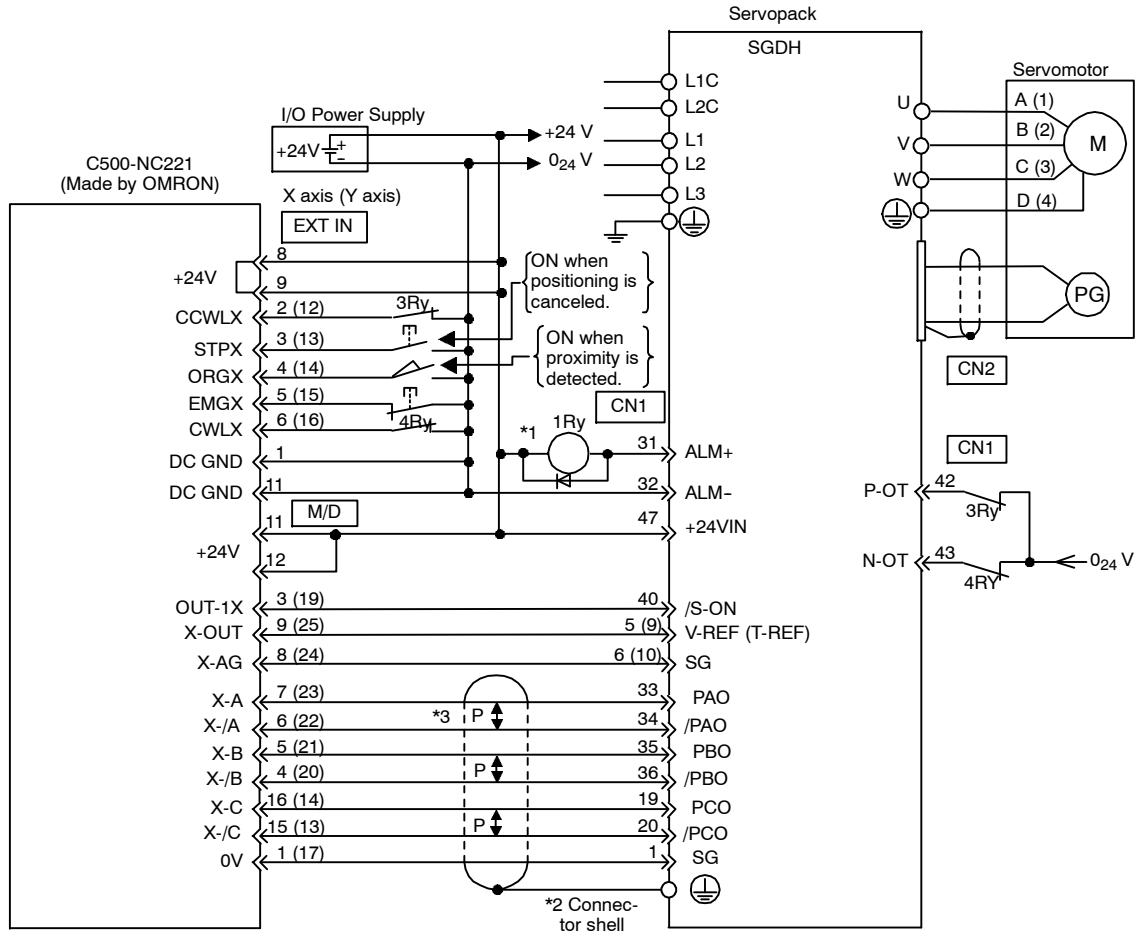

- * 1. The ALM signal is output for approximately two seconds when the power is turned ON. Take this into consideration when designing the power ON sequence. The ALM signal actuates the alarm detection relay 1Ry to stop main circuit power supply to the Servopack.
- * 2. Connect the shield wire of the I/O cable to the connector shell.
- * 3. \updownarrow P indicates twisted-pair wires.

Note Only signals applicable to OMRON's C500-NC221 Position Control Unit and Yaskawa's SGDH Servopack are shown here.

A.5 Connecting OMRON's C500-NC112 Position Control Unit

The following diagram shows an example of connecting to the OMRON C500-NC112 Position Control Unit. In this example, the Servopack is used in the position control mode.

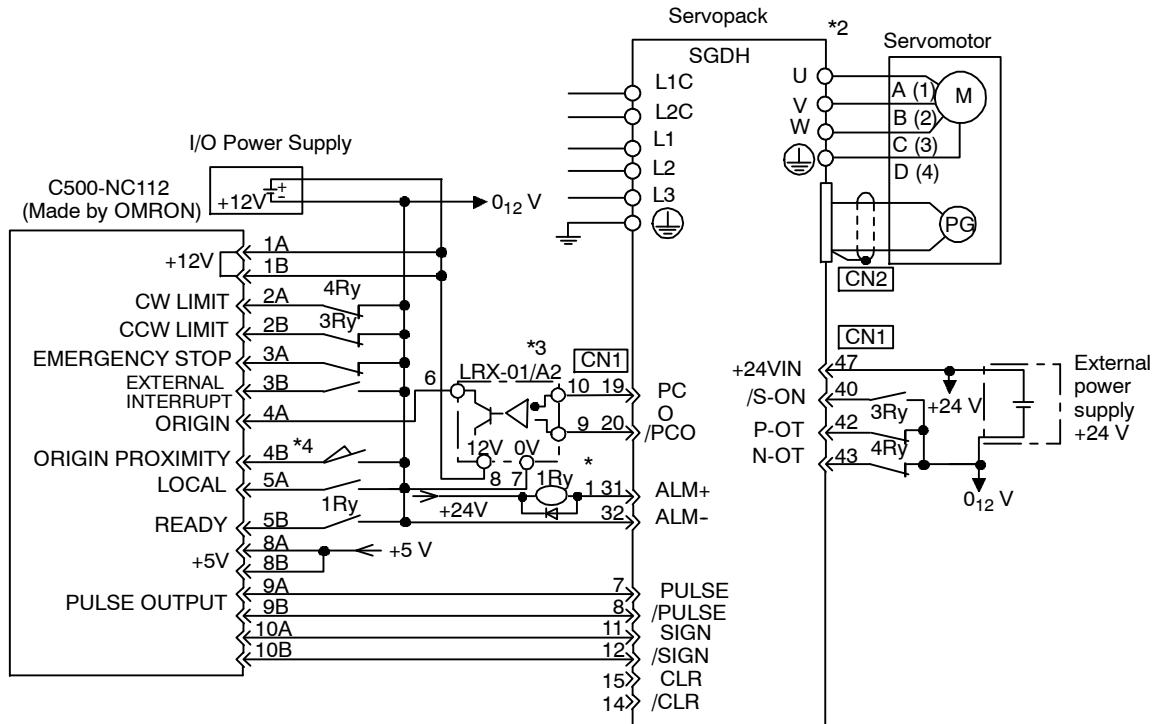

- * 1. The ALM signal is output for approximately two seconds when the power is turned ON. Take this into consideration when designing the power ON sequence. The ALM signal actuates the alarm detection relay 1Ry to stop main circuit power supply to Servopack.
- * 2. Set user constant Pn200.0 to "1".
- * 3. Manufactured by Yaskawa Controls Co., Ltd.

Note Only signals applicable to OMRON's C500-NC112 Position Control Unit and Yaskawa's SGDH Servopack are shown here.

A.6 Connecting MITSUBISHI's AD72 Positioning Unit

The following diagram shows an example of connecting to the MITSUBISHI AD72 Positioning Unit. In this example, the Servopack is used in Speed Control Mode.

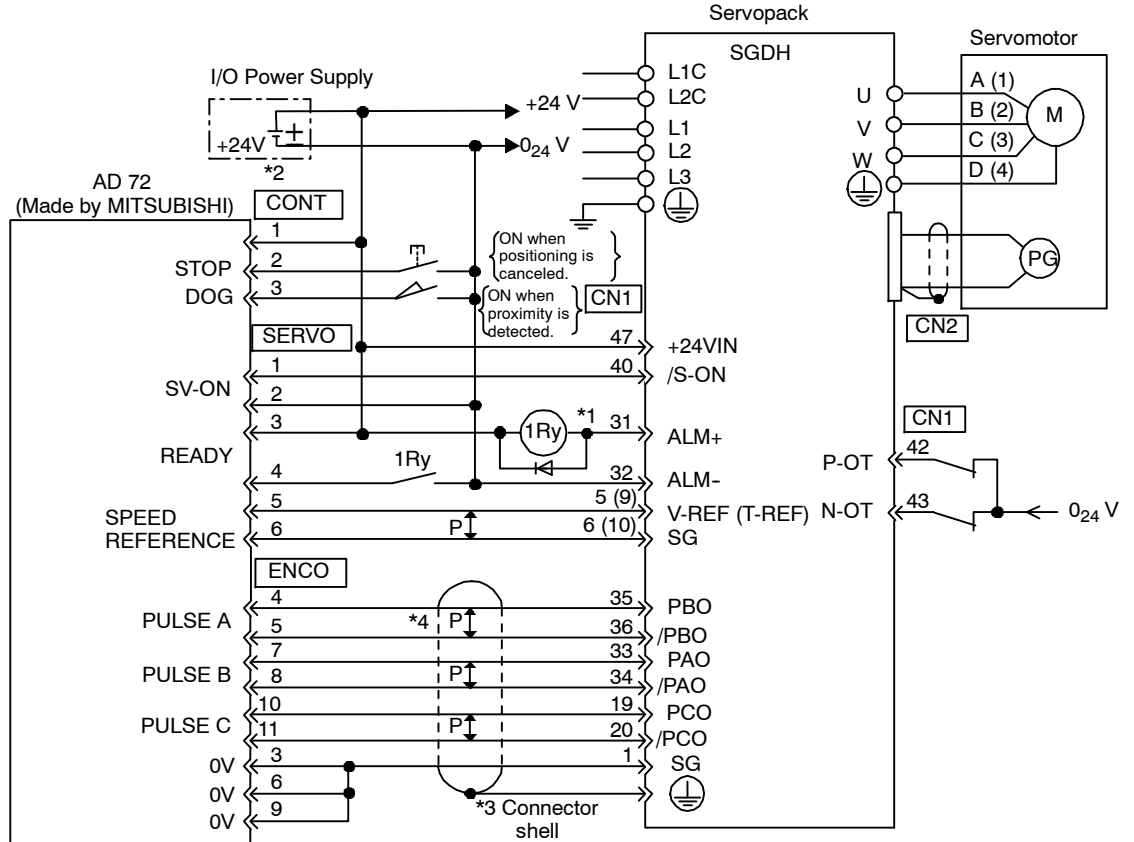

- * 1. The ALM signal is output for approximately two seconds when the power is turned ON. Take this into consideration when designing the power ON sequence. The ALM signal actuates the alarm detection relay 1Ry to stop main circuit power supply to Servopack.
- * 2. Pin numbers are the same both for X axis and Y axis.
- * 3. Connect the connector wire of the cable to the connector shell.
- * 4. \updownarrow P indicates twisted-pair wires.

Note Only signals applicable to Mitsubishi's AD72 Positioning Unit and Yaskawa's SGDh Servopack are shown here.

A.7 Connecting MITSUBISHI's AD75 Positioning Unit

The following diagram shows an example of connecting to the MITSUBISHI AD75 Positioning Unit. In this example, the Servopack is used in Position Control Mode.

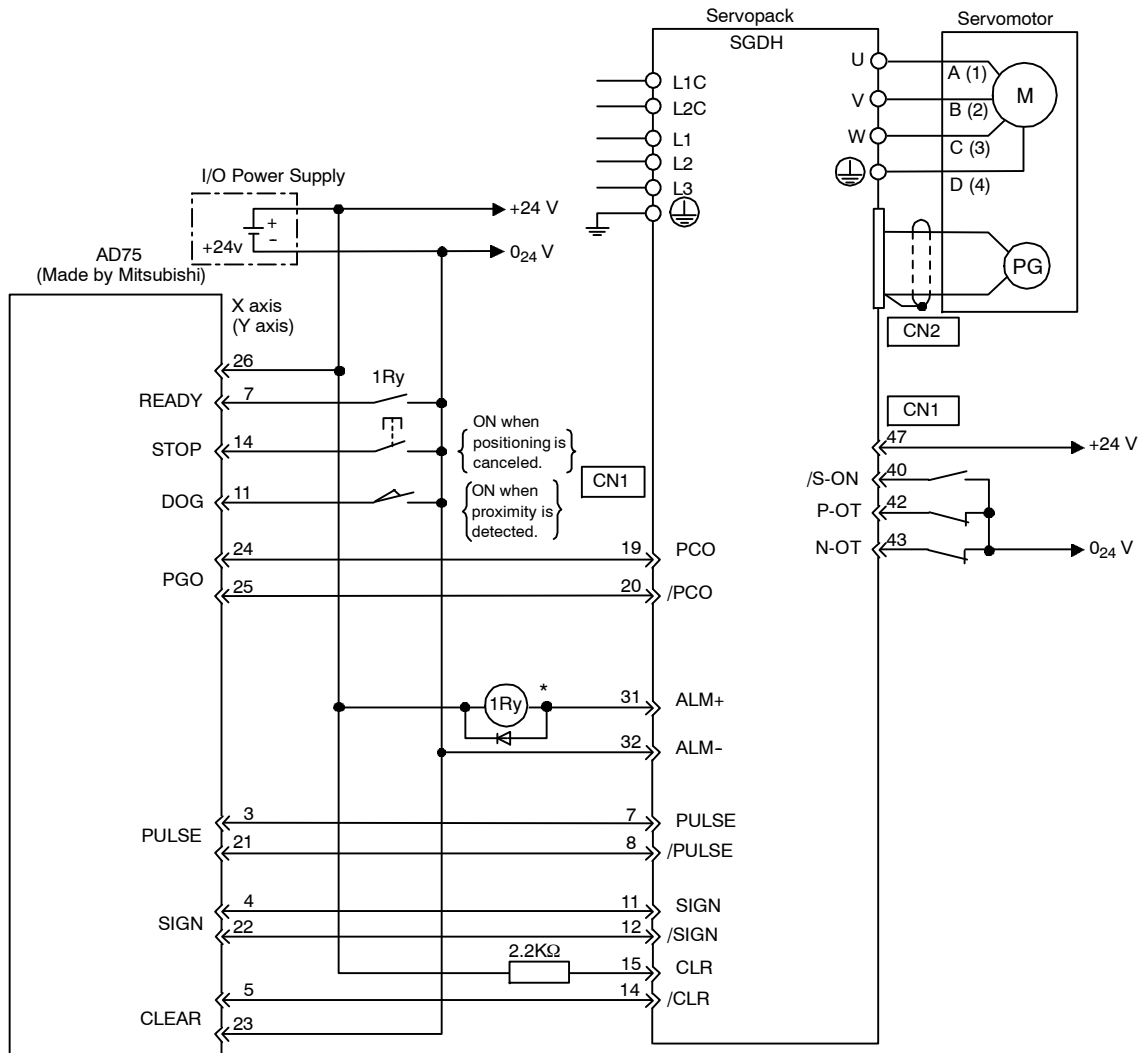

* The ALM signal is output for approximately two seconds when the power is turned ON. Take this into consideration when designing the power ON sequence. The ALM signal actuates the alarm detection relay 1Ry to stop main circuit power supply to Servopack.

Note Only signals applicable to MITSUBISHI's AD75 Positioning Unit and Yaskawa's SGDH Servopack are shown here.

B

List of User Constants

B

This appendix lists the user constants, switches, input signal selections, output signal selections, auxiliary functions, and monitor modes for SGDH Servopacks.

B.1 User Constants	B - 2
B.2 Switches	B - 6
B.3 Input Signal Selections	B - 11
B.4 Output Signal Selections	B - 13
B.5 Auxiliary Functions	B - 15
B.6 Monitor Modes	B - 16

B.1 User Constants

The following list shows user constants and their settings.

Category	User Constant No.	Name	Unit	Setting Range	Factory Setting	Reference
Function Selection Constants	Pn000	Function Selection Basic Switches (See note 3.)	---	---	0000	5.1.1 5.3.5
	Pn001	Function Selection Application Switches 1 (See note 3.)	---	---	0000	5.1.2 5.4.2 5.5.7
	Pn002	Function Selection Application Switches 2 (See note 3.)	---	---	0000	5.2.8 5.2.10 5.7.2
	Pn003	Function Selection Application Switches 3	---	---	0002	6.5
	Pn004	Fixed constants (Do not change.)	---	---	0000	---
	Pn005		---	---	0000	---
Gain Related Constants	Pn100	Speed Loop Gain	Hz	1 to 2000	40	---
	Pn101	Speed Loop Integral Time Constant	0.01 ms	15 to 51200	2000	6.2.1
	Pn102	Position Loop Gain	1/s	1 to 2000	40	6.2.1
	Pn103	Inertia Ratio	%	0 to 10000	0	6.2.1 6.3.3
	Pn104	2nd Speed Loop Gain	Hz	1 to 2000	40	---
	Pn105	2nd Speed Loop Integral Time Constant	0.01 ms	15 to 51200	2000	---
	Pn106	2nd Position Loop Gain	1/s	1 to 2000	40	---
	Pn107	Bias	r/min	0 to 450	0	6.2.4
	Pn108	Bias Width Addition	reference units	0 to 250	7	6.2.4
	Pn109	Feed-forward	%	0 to 100	0	6.2.2
	Pn10A	Feed-forward Filter Time Constant	0.01 ms	0 to 6400	0	5.2.5
	Pn10B	Gain-related Application Switches (See note 3.)	---	---	0000	6.2.5
	Pn10C	Mode Switch Torque Reference	%	0 to 800	200	6.2.5
	Pn10D	Mode Switch Speed Reference	r/min	0 to 10000	0	6.2.5
	Pn10E	Mode Switch Acceleration	10 r/min/s	0 to 3000	0	6.2.5
	Pn10F	Mode Switch Error Pulse	reference units	0 to 10000	0	6.2.5
	Pn110	Online Autotuning Switches (See note 3.)	---	---	0010	6.3.4
Pn111	Speed Feedback Compensation (See note 2.)	%	1 to 500	100	6.2.6	

Category	User Constant No.	Name	Unit	Setting Range	Factory Setting	Reference
Gain Related Constants	Pn112	Fixed constants (Do not change.)	%	0 to 1000	100	---
	Pn113		---	0 to 1000	1000	---
	Pn114		---	0 to 1000	200	---
	Pn115		---	0 to 65535	32	---
	Pn116		---	0 to 65535	16	---
	Pn117		%	20 to 100	100	---
	Pn118		%	20 to 100	100	---
	Pn119		1/S	1 to 2000	50	---
	Pn11A		0.1%	1 to 2000	1000	---
	Pn11B		Hz	1 to 150	50	---
	Pn11C		Hz	1 to 150	70	---
	Pn11D		%	0 to 150	100	---
	Pn11E		%	0 to 150	100	---
	Pn11F		ms	0 to 2000	0	---
	Pn120		0.01 ms	0 to 51200	0	---
Pn121	Hz	10 to 250	50	---		
Pn122	Hz	0 to 250	0	---		
Pn123	%	0 to 100	0	---		
Position Related Constants	Pn200	Position Control Reference Selection Switches (See note 3.)	---	---	0000	5.2.2
	Pn201	PG Divider (See note 3.)	p/r	16 to 16384	16384	5.2.3
	Pn202	Electronic Gear Ratio (Numerator) (See note 3.)	---	1 to 65535	4	5.2.5
	Pn203	Electronic Gear Ratio (Denominator) (See note 3.)	---	1 to 65535	1	5.2.5
	Pn204	Position Reference Accel/Decel Constant	0.01 ms	0 to 6400	0	6.1.2
	Pn205	Multi-turn Limit Setting (See notes 1 and 3.)	rev	0 to 65535	65535	5.7.6
	Pn206	Fixed constants (Do not change.)	P/rev	513 to 65535	16384	-
	Pn207	Position Control Function Switches (See note 3.)	-	-	0000	5.2.9 6.1.2
	Pn208	Position Reference Movement Averaging Time (See note 3.)	0.01 ms	0 to 6400	0	6.1.2

Category	User Constant No.	Name	Unit	Setting Range	Factory Setting	Reference
Speed Related Constants	Pn300	Speed Reference Input Gain	0.01 V/ rated speed	150 to 3000	600	5.2.1
	Pn301	Speed 1	r/min	0 to 10000	100	5.2.6
	Pn302	Speed 2	r/min	0 to 10000	200	5.2.6
	Pn303	Speed 3	r/min	0 to 10000	300	5.2.6
	Pn304	Jog Speed	r/min	0 to 10000	500	5.3.2
	Pn305	Soft Start Acceleration Time	ms	0 to 10000	0	6.1.1
	Pn306	Soft Start Deceleration Time	ms	0 to 10000	0	6.1.1
	Pn307	Speed Reference Filter Time Constant	0.01 ms	0 to 65535	40	---
	Pn308	Speed Feed-forward Filter Time Constant	0.01 ms	0 to 65535	0	---
Torque related constants	Pn400	Torque Reference Input Gain	0.1 V/rated torque	10 to 100	30	5.2.7
	Pn401	Torque Reference Filter Time Constant	0.01 ms	0 to 65535	100	6.1.5
	Pn402	Forward Torque Limit	%	0 to 800	800	5.1.3
	Pn403	Reverse Torque Limit	%	0 to 800	800	5.1.3
	Pn404	Forward External Torque Limit	%	0 to 800	100	5.1.3
	Pn405	Reverse External Torque Limit	%	0 to 800	100	5.1.3
	Pn406	Emergency Stop Torque	%	0 to 800	800	5.1.2
	Pn407	Speed Limit during Torque Control	r/min	0 to 10000	10000	5.2.7
	Pn408	Torque Function Switches	---	---	0000	6.1.6
Pn409	Notch Filter Frequency	Hz	50 to 2000	2000	6.1.6	

Category	User Constant No.	Name	Unit	Setting Range	Factory Setting	Reference
Sequence related constants	Pn500	Positioning Completed Width	reference units	0 to 250	7	5.5.3
	Pn501	Zero Clamp Level	r/min	0 to 10000	10	5.4.3
	Pn502	Rotation Detection Level	r/min	1 to 10000	20	5.5.5
	Pn503	Speed Coincidence Signal Output Width	r/min	0 to 100	10	5.5.4
	Pn504	NEAR Signal Width	reference units	1 to 250	7	5.5.8
	Pn505	Overflow Level	256 reference units	1 to 32767	1024	6.2.1
	Pn506	Brake Reference Servo OFF Delay Time	10 ms	0 to 50	0	5.4.4
	Pn507	Brake Reference Output Speed Level	r/min	0 to 10000	100	5.4.4
	Pn508	Timing for Brake Reference Output during Motor Operation	10 ms	10 to 100	50	5.4.4
	Pn509	Momentary Hold Time	ms	20 to 1000	20	5.5.9
	Pn50A	Input Signal Selections 1 (See note 3.)	---	---	2100	5.3.3
	Pn50B	Input Signal Selections 2 (See note 3.)	---	---	6543	5.3.3
	Pn50C	Input Signal Selections 3 (See note 3.)	---	---	8888	5.3.3
	Pn50D	Input Signal Selections 4 (See note 3.)	---	---	8888	5.3.3
	Pn50E	Output Signal Selections 1 (See note 3.)	---	---	3211	5.3.4
	Pn50F	Output Signal Selections 2 (See note 3.)	---	---	0000	5.3.4
	Pn510	Output Signal Selections 3 (See note 3.)	---	---	0000	5.3.4
	Pn511	Reserved constant (Do not change.)	---	---	8888	---
Pn512	Output Signal Reversal Settings (See note 3.)	---	---	0000	5.3.4	
Other constants	Pn600	Regenerative Resistor Capacity (See note 4.)	10 W	0 to capacity ^{*5}	0	5.6.1
	Pn601	Fixed constant (Do not change.)	---	0 to capacity ^{*5}	0	---

- * 1. The multiturn limit must be changed only for special applications. Changing this limit inappropriate or unintentionally can be dangerous.
- * 2. The setting of user constant Pn111 is valid only when user constant Pn110.1 is set to 0.
- * 3. After changing these user constants, turn OFF the main circuit and control power supplies and then turn them ON again to enable the new settings. (except Pn 110.1 and Pn 110.2)
- * 4. Normally set to "0". When using an External Regenerative Resistor, set the capacity (W) of the regenerative resistor.
- * 5. The upper limit is the maximum output capacity (W) of the Servopack.

B.2 Switches

The following list shows the switches and their factory settings.

User Constant	Digit Place	Name	Setting	Contents	Factory Setting
Pn000 Function Selection Basic Switches	0	Direction Selection	0	Sets CCW as forward direction.	0
			1	Sets CW as forward direction (reverse rotation mode).	
	1	Control Method Selection	0	Speed control (analog reference)	0
			1	Position control (pulse train reference)	
			2	Torque control (analog reference)	
			3	Internal set speed control (contact reference)	
			4	Internal set speed control (contact reference)/Speed control (analog reference)	
			5	Internal set speed control (contact reference)/Position control (pulse train reference)	
			6	Internal set speed control (contact reference)/Torque control (analog reference)	
			7	Position control (pulse train reference)/Speed control (analog reference)	
			8	Position control (pulse train reference)/Torque control (analog reference)	
			9	Torque control (analog reference)/Speed control (analog reference)	
			A	Speed control (analog reference)/Zero clamp	
			B	Position control (pulse train reference)/Position control (Inhibit)	
	2	Axis Address	0 to F	Sets Servopack axis address.	0
3	Reserved		---	0	

User Constant	Digit Place	Name	Setting	Contents	Factory Setting	
Pn001 Function Selection Application Switches	0	Servo OFF or Alarm Stop Mode	0	Stops the motor by applying dynamic brake (DB).	0	
			1	Stops the motor by applying dynamic brake (DB) and then releases DB.		
			2	Makes the motor coast to a stop state without using the dynamic brake (DB).		
	1	Overtravel Stop Mode	0	Same setting as Pn001.0 (Stops the motor by applying DB or by coasting.)	0	
			1	Sets the torque of Pn406 to the maximum value, decelerates the motor to a stop, and then sets it to servolock state.		
			2	Sets the torque of Pn406 to the maximum value, decelerates the motor to a stop, and then sets it to coasting state.		
	2	AC/DC Power Input Selection	0	Not applicable to DC power input: Input AC power supply through L1, L2, and (L3) terminals.	0	
			1	Applicable to DC power input: Input DC power supply through (+)1 and (-) terminals.		
	3	Warning Code Out- put Selection	0	ALO1, ALO2, and ALO3 output only alarm codes.	0	
			1	ALO1, ALO2, and ALO3 output both alarm codes and warning codes. While warning codes are output, ALM signal output remains ON (normal state).		
	Pn002 Function Selection Application Switches	0	Speed, Position Control Option (T-REF Terminal Allocation)	0	None	0
				1	Uses T-REF as an external torque limit input.	
2				Uses T-REF as a torque feed-forward input.		
3				Uses T-REF as an external torque limit input when P-CL and N-CL are ON.		
1		Torque Control Op- tion (V-REF Termi- nal Allocation)	0	None	0	
			1	Uses V-REF as an external speed limit input.		
2		Absolute Encoder Usage	0	Uses absolute encoder as an absolute encoder.	0	
			1	Uses absolute encoder as an incremental en- coder.		
3		Fixed constant (Do not change.)	0 to 4	---	0	

User Constant	Digit Place	Name	Setting	Contents	Factory Setting
Pn003 Function Selection Application Switches	0	Analog Monitor 1 Torque Reference Monitor	0	Motor speed: 1 V/1000 r/min.	2
			1	Speed reference: 1 V/1000 r/min.	
	1	Analog Monitor 2 Speed Reference Monitor	2	Torque reference: 1 V/100%	0
			3	Position error: 0.05 V/1 reference unit	
			4	Position error: 0.05 V/100 reference unit	
			5	Reference pulse frequency (converted to r/min): 1 V/1000 r/min.	
			6	Motor speed × 4: 1 V/250 r/min.	
			7	Motor speed × 8: 1 V/125 r/min.	
			8	Fixed constant (Do not change.)	
			9		
			A		
			B		
	C				
	D				
		E			
		F			
2	Not used.		---	0	
3	Not used.		---	0	
Pn10B Gain Application Switches	0	Mode Switch Selec- tion	0	Uses internal torque reference as the condition (Level setting: Pn10C)	0
			1	Uses speed reference as the condition (Level setting: Pn10D)	
			2	Uses acceleration as the condition (Level set- ting: Pn10E)	
			3	Uses error pulse as the condition (Level set- ting: Pn10F)	
			4	No mode switch function available	
	1	Speed Loop Control Method	0	PI control	0
			1	IP control	
	2	Not used.	0	---	0
3	Fixed constant (Do not change.)	0 to 2	---	0	

User Constant	Digit Place	Name	Setting	Contents	Factory Setting
Pn110 Online Autotuning Switches	0	Online Autotuning Method	0	Tunes only at the beginning of operation.	0
			1	Always tunes.	
			2	Does not perform autotuning.	
	1	Speed Feedback Compensation Selection	0	Enabled	1
			1	Disabled	
	2	Friction Compensa- tion Selection	0	Friction compensation: Disabled	0
			1	Friction compensation: Small	
			2	Friction compensation: Large	
	3	Fixed Constant (Do not change.)	0 to 3	---	0
	Pn200 Position Control References Selection Switches	0	Reference Pulse Form	0	Sign + pulse, positive logic
1				CW + CCW, positive logic	
2				A phase + B phase (x1), positive logic	
3				A phase + B phase (x2), positive logic	
4				A phase + B phase (x4), positive logic	
5				Sign + pulse, negative logic	
6				CW + CCW, negative logic	
7				A phase + B phase (x1), negative logic	
8				A phase + B phase (x2), negative logic	
9				A phase + B phase (x4), negative logic	
1		Error Counter Clear Signal Form	0	Clears error counter when the signal goes high.	0
			1	Clears error counter at the rising edge of the signal.	
			2	Clears error counter when the signal goes low.	
			3	Clears error counter at the falling edge of the signal.	
2		Clear Operation	0	Clears error counter at the baseblock.	0
			1	Does not clear error counter. (Possible to clear error counter only with CLR signal.)	
			2	Clears error counter when an alarm occurs.	
3		Filter Selection	0	Reference input filter for line driver signals.	0
			1	Reference input filter for open collector signals.	
Pn207 Position Control Function Switches		0	Position Reference Filter Selection	0	Acceleration/deceleration filter
	1			Average movement filter	
	1	Position Control Op- tion	0	Disabled.	0
			1	Uses V-REF as a speed feed-forward input.	
	2	Not used.		---	0
	3	Not used.		---	0

User Constant	Digit Place	Name	Setting	Contents	Factory Setting
Pn408 Torque Function Switches	0	Notch Filter Selection	0	Disabled.	0
			1	Uses a notch filter for torque reference.	
	1	Not used.		---	0
	2	Not used.		---	0
	3	Not used.		---	0

B.3 Input Signal Selections

The following list shows input signal selections and their factory settings.

User Constant	Digit Place	Name	Setting	Contents	Factory Setting
Pn50A	0	Input Signal Allocation Mode	0	Sets the input signal allocation for the sequence to the same one as for the SGDB Servopack. *1	0
			1	Possible to freely allocate the input signals.	
	1	/S-ON Signal Mapping (Servo ON when low.)	0	Inputs from the SI0 (CN1-40) input terminal.	0: SI0
			1	Inputs from the SI1 (CN1-41) input terminal.	
			2	Inputs from the SI2 (CN1-42) input terminal.	
			3	Inputs from the SI3 (CN1-43) input terminal.	
			4	Inputs from the SI4 (CN1-44) input terminal.	
			5	Inputs from the SI5 (CN1-45) input terminal.	
			6	Inputs from the SI6 (CN1-46) input terminal.	
			7	Sets signal ON.	
			8	Sets signal OFF.	
			9	Inputs the reverse signal from the SI0 (CN1-40) input terminal.	
			A	Inputs the reverse signal from the SI1 (CN1-41) input terminal.	
			B	Inputs the reverse signal from the SI2 (CN1-42) input terminal.	
			C	Inputs the reverse signal from the SI3 (CN1-43) input terminal.	
			D	Inputs the reverse signal from the SI4 (CN1-44) input terminal.	
			E	Inputs the reverse signal from the SI5 (CN1-45) input terminal.	
F	Inputs the reverse signal from the SI6 (CN1-46) input terminal.				
Pn50A	2	/P-CON Signal Mapping (P control when low.)	0 to F	Same as above.	1: SI1
	3	P-OT Signal Mapping (Overtravel when high.)	0 to F	Same as above.	2: SI2

User Constant	Digit Place	Name	Setting	Contents	Factory Setting
Pn50B	0	N-OT Signal Mapping (Over-travel when high.)	0 to F	Same as above.	3: SI3
	1	/ALM-RST Signal Mapping (Alarm reset when low.)	0 to F	Same as above.	4: SI4
	2	/P-CL Signal Mapping (Torque control when low.)	0 to F	Same as above.	5: SI5
	3	/N-CL Signal Mapping (Torque control when low.)	0 to F	Same as above.	6: SI6
Pn50C	0	/SPD-D Signal Mapping (Internal Set Speed Selection)	0 to F	Same as above.	8: OFF
	1	/SPD-A Signal Mapping (Internal Set Speed Selection)	0 to F	Same as above.	8: OFF
	2	/SPD-B Signal Mapping (Internal Set Speed Selection)	0 to F	Same as above.	8: OFF
	3	/C-SEL Signal Mapping (Control Mode Switching)	0 to F	Same as above.	8: OFF
Pn50D	0	/ZCLAMP Signal Mapping (Zero Clamping)	0 to F	Same as above.	8: OFF
	1	/INHIBIT Signal Mapping (Disabling Reference Pulse)	0 to F	Same as above.	8: OFF
	2	/G-SEL Signal Mapping (Gain Switching)	0 to F	Same as above.	8: OFF
	3	(Reserved)	0 to F	Same as above.	8: OFF

* When Pn50A.0 is set to 0 for the SGDB Servopack, only the following modes are compatible: Pn50A.1=7, Pn50A.3=8, and Pn50B.0=8.

B.4 Output Signal Selections

The following list shows output signal selections and their factory settings.

User Constant	Digit Place	Name	Setting	Contents	Factory Setting
Pn50E	0	/COIN Signal Mapping	0	Disabled.	1: SO1
			1	Outputs from the SO1 (CN1-25, 26) output terminal.	
			2	Outputs from the SO2 (CN1-27, 28) output terminal.	
			3	Outputs from the SO3 (CN1-29, 30) output terminal.	
	1	/V-CMP Signal Mapping	0 to 3	Same as above.	1: SO1
	2	/TGON Signal Mapping	0 to 3	Same as above.	2: SO2
3	/S-RDY Signal Mapping	0 to 3	Same as above.	3: SO3	
Pn50F	0	/CLT Signal Mapping	0 to 3	Same as above.	0: Not used
	1	/VLT Signal Mapping	0 to 3	Same as above.	
	2	/BK Signal Mapping	0 to 3	Same as above.	
	3	/WARN Signal Mapping	0 to 3	Same as above.	
Pn510	0	/NEAR Signal Mapping	0 to 3	Same as above.	0
	1	Reserved	0 to 3	Same as above.	
	2	Not used.	0	---	
	3	Not used.	0	---	
Pn512	0	Output Signal Reversal for SO1 (CN1-25 and 26)	0	Output signal is not reversed.	0: Not reversed
			1	Output signal is reversed.	
	1	Output Signal Reversal for SO2 (CN1-27 and 28)	0	Output signal is not reversed.	0: Not reversed
			1	Output signal is reversed.	
	2	Output Signal Reversal for SO3 (CN1-29 and 30)	0	Output signal is not reversed.	0: Not reversed
			1	Output signal is reversed.	
3	Not used.	---	---	0	

- Note 1.** When more than one signal is allocated to the same output circuit, data is output using OR logic.
2. Depending on the control mode, undetected signals are treated as OFF. For example, in the speed control mode, the /COIN signal is treated as OFF.
 3. Types of /WARN signals: Overload and regenerative overload.

B.5 Auxiliary Functions

The following list shows the available auxiliary functions.

User Constant	Function
Fn000	Alarm traceback data display.
Fn001	Rigidity setting during online autotuning.
Fn002	JOG mode operation.
Fn003	Zero-point search mode.
Fn004	(Fixed constant)
Fn005	User constant settings initialization.
Fn006	Alarm traceback data clear.
Fn007	Writing to EEPROM inertia ratio data obtained from online autotuning.
Fn008	Absolute encoder multi-turn reset and encoder alarm reset.
Fn009	Automatic tuning of analog (speed, torque) reference offset.
Fn00A	Manual adjustment of speed reference offset.
Fn00B	Manual adjustment of torque reference offset.
Fn00C	Manual zero-adjustment of analog monitor output.
Fn00D	Manual gain-adjustment of analog monitor output.
Fn00E	Automatic offset-adjustment of motor current detection signal.
Fn00F	Manual offset-adjustment of motor current detection signal.
Fn010	Password setting (protects user constants from being changed).
Fn011	Motor models display.
Fn012	Software version display.
Fn013	Multiturn limit setting change when a Multiturn Limit Disagreement Alarm (A.CC) occurs.
Fn014	Option unit detection results clear.

B.6 Monitor Modes

The following list shows monitor modes available.

User Constant	Content of Display	Unit	Remarks
Un000	Actual motor speed	r/min	---
Un001	Input speed reference	r/min	---
Un002	Internal torque reference	%	Value for rated torque
Un003	Rotation angle 1	pulse	Number of pulses from the origin
Un004	Rotation angle 2	deg	Angle from the origin (electrical angle)
Un005	Input signal monitor	---	---
Un006	Output signal monitor	---	---
Un007	Input reference pulse speed	r/min	---
Un008	Error counter value	reference units	Amount of position error
Un009	Accumulated load rate	%	Value for the rated torque as 100% Displays effective torque in 10-s cycle.
Un00A	Regenerative load rate	%	Value for the processable regenerative power as 100% Displays effective torque in 10-s cycle.
Un00B	Power consumed by DB resistance	%	Value for the processable power when dynamic brake is applied as 100% Displays effective torque in 10-s cycle.
Un00C	Input reference pulse counter	---	Displayed in hexadecimal.
Un00D	Feedback pulse counter	---	Displayed in hexadecimal.

INDEX

Symbols

/ALM-RST input signal, 5 -69
 /BK signal, 5 -67
 /CLT signal, 5 -10
 /N-CL signal, 5 -12
 /P-CL signal, 5 -12
 /P-CON signal, 5 -34, 5 -40, 5 -47
 using the, 5 -15
 /TGON signal, 5 -74

A

absolute data, 5 -98
 absolute encoders, 3 -27, 5 -92
 battery replacement, 9 -4
 mounted to Servomotor, 5 -93
 multiturn limit setting, 5 -101
 reception sequence, 5 -97
 selecting, 5 -94
 setup, 5 -95
 transmission sequence, 5 -98
 absolute signals, 5 -97
 absorbable energy, 5 -90
 acceleration, used as detection point, 6 -12
 adjusting gain, 6 -4
 adjusting offset, 6 -4
 alarm code, outputs, 5 -68
 alarm contents, transferring, 5 -101
 alarm display, table, 9 -34
 alarm displays, used for troubleshooting, 9 -5
 alarm traceback data, clearing, 7 -32
 alarm traceback mode, 7 -21
 alarms, checking, 7 -21
 analog input circuit, 3 -24
 analog monitor, 6 -33, 7 -42
 analog signals, 3 -24
 analog voltage reference
 function 1, 5 -44
 function 2, 5 -45
 automatic adjustment, of speed and torque reference offset, 7 -25
 autotuning, 6 -16
 auxiliary functions, B -15

B

batteries, 5 -94
 absolute encoder, 9 -4
 bias function, 6 -31
 brake ON timing, 5 -66
 Built-in Panel Operator, 5 -96, 5 -103, 6 -20, 6 -22, 7 -2, 7 -9

C

cable stress, 2 -6
 cables
 encoder, 5 -114
 specifications, 3 -14
 CN1
 specifications, 3 -20
 terminal layout, 3 -20
 CN2
 connector models, 3 -28
 connector terminal layout, 3 -28
 contact input speed control, 5 -31
 example, 5 -35
 operation by, 5 -33
 selection, 5 -58, 5 -59
 using, 5 -31
 control modes
 description, 5 -58
 selection, 5 -58
 control panel, Servopacks, 2 -9
 cooling, Servopacks, 2 -9
 CP-9200SH Servo Controller Module, A -3
 current loop, 6 -25

D

DATA/ENTER Key, 6 -19
 DATA/SHIFT Key, 7 -9
 DC reactor, 5 -117
 detection point, 6 -11, 6 -12, 6 -13
 Digital Operator, 7 -1
 See also Built-in Panel Operator; Hand-held Digital Operator
 alarm traceback mode, 7 -21
 basic mode selection, 7 -5
 connecting the, 7 -2
 functions, 7 -3
 initializing user constant settings, 7 -40
 monitor mode, 7 -14

- origin search mode, 7 -38
- password setting, 7 -51
- position control mode, 7 -7
- reference offset automatic adjustment mode, 7 -25
- reference offset manual adjustment mode, 7 -28
- speed and torque display mode, 7 -6
- status display mode, 7 -5
- types, 7 -2
- user constant setting mode, 7 -8

- dimensional drawings
 - Servopacks, 8 -40
 - SGMAH Servomotors, 8 -6
 - SGMDH Servomotors, 8 -24
 - SGMGH Servomotors, 8 -14, 8 -18
 - SGMPH Servomotors, 8 -9
 - SGMSH Servomotors, 8 -21

- DSPL/SET Key, 6 -19

- dynamic brake, 5 -61

E

- electronic gear, setting the, 5 -27
 - examples, 5 -29

- electronic gear function, 5 -27

- encoder alarms, resetting, 5 -69

- encoder signal output, 5 -21

- encoders

- absolute, 3 -27, 5 -92
 - battery replacement, 9 -4
 - multiturn limit setting, 5 -101
 - reception sequence, 5 -97
 - selecting, 5 -94
 - setup, 5 -95
 - transmission sequence, 5 -98
- cables, 5 -114
- incremental, 3 -27
- wiring to Servopack, 3 -27

- error counter, clearing, 5 -19

- error pulses, used as detection point, 6 -13

- external power supply input, 24 V, 5 -26

F

- feed-forward control, 6 -8

- feed-forward functions, 6 -31
 - speed, 5 -43
 - torque, 5 -42

- feedback loops, 6 -25

- feedback pulse counter monitor display, 7 -19

- forward rotation prohibited signal, 7 -23, 7 -38

- friction compensation, 6 -24

- functions, selection, 7 -10

- fuse capacity, 5 -107

G

- gain, adjusting, 6 -4, 7 -42, 7 -45

- GL-series B2813 Positioning Module, A -4

- GL-series MC20 Motion Module, A -2

- grounding, 5 -108, 5 -110

H

- Hand-held Digital Operator, 5 -95, 5 -103, 6 -19, 6 -21, 7 -2
 - using the, 7 -8

- harmonic suppression, 5 -117

- high-speed positioning, 6 -6

- holding brake, 5 -64, 5 -67

- host controller connection examples, A -1

- host controller input circuit, 5 -14

- host controllers, 3 -6

I

- I/O signal generation, timing example, 5 -18

- I/O signals, 5 -22

- names and functions, 3 -21
 - SGDM Servopack, 3 -18
 - used for protective sequence, 5 -68

- incremental encoders, 3 -27

- incremental pulses, 5 -100

- index, 6 -31

- inertia ratio, 6 -6

- INHIBIT, 5 -47

- INHIBIT function, 5 -47

- INHIBIT signal, and reference pulses, 5 -47

- input pulse multiplier, 5 -18

- input signal monitor display, 7 -17

- input signals, 3 -21, 4 -13
 - allocation, 5 -49
 - enabling and disabling, 5 -6
 - required for trial operation, 4 -12
 - selections, B -11

- inspection, 9 -1

- Servomotors, 9 -2

- Servopacks, 9 -3

- installation, Servopacks, 2 -9

- installation direction, Servomotors, 2 -3

installation site
 Servomotors, 2 -3
 Servopacks, 2 -8

insufficient voltage alarm, 5 -79

integral time constant, 6 -6

interface circuit, absolute encoder and Servomotor, 5 -93

interface circuits, 3 -24

interlock, 5 -72

J

JOG speed, 5 -49

L

line driver output circuit, connecting to, 3 -25

line-driver output, connection example, 5 -15

load inertia, 6 -6, 6 -16

M

main circuit
 power supply, 5 -79
 terminal blocks, wiring, 3 -16
 terminals, 3 -13
 wiring, 3 -12
 example, 3 -14
 precautions, 3 -12

maintenance, 9 -1

manual adjustment, of speed and torque reference offset, 7 -28

manual adjustments, 6 -27

manual zero adjustment, 7 -42

MCCB capacity, 5 -107

mechanical rigidity settings, for online autotuning, 6 -19

Mitsubishi
 AD72 Positioning Unit, A -7
 AD75 Positioning Unit, A -8

mode switch function, 6 -10

mode switch, 6 -10

monitor modes, B -16

motor current detection offset, 7 -47

motor model, checking the, 7 -34

multiturn limit setting, 5 -101

N

near output signal, 5 -77

noise control, 5 -109

noise filters, 5 -110

notch filter, 6 -5

O

offset
 adjusting, 5 -60, 6 -4
 automatic adjustment, 7 -25
 manual adjustment, 7 -28

oil and water, Servomotors, 2 -6

OMRON
 C500-NC112 Position Control Unit, A -6
 C500-NC221 Position Control Unit, A -5

online autotuning, 6 -16
 mechanical rigidity settings for, 6 -19
 related user constants, 6 -23
 saving results of, 6 -21
 setting user constants for, 6 -18

open collector output circuit, connecting to, 3 -26

open-collector output, connection example, 5 -16

operating conditions, Servopacks, 9 -3

orientation
 Servomotors, 2 -3
 Servopacks, 2 -8

origin pulses, 5 -100

output circuit interfaces, 3 -25

output pulse form, 5 -22

output signal monitor display, 7 -18

output signals, 3 -22
 allocation, 5 -55
 selections, B -13

overload signal, 5 -76

overshooting, 6 -10

overtravel limit function
 setting the, 5 -5
 using the, 5 -5

P

Panel Operator, using the. *See* Built-in Panel Operator

PAO serial data, specifications, 5 -99

peripheral devices, 3 -14
 connecting to, 3 -3
 single-phase specifications, 3 -4
 three-phase specifications, 3 -5, 3 -6

PG dividing ratio, 5 -100

PG dividing ratio setting, 5 -22

photocoupler output circuit, connecting to, 3 -26

photocoupler output signals, 5 -68, 5 -72

position control, 6 -29

position control (inhibit), 5 -59

position control (pulse train reference), 5 -59

Position Control Mode, 3 -35
 trial operation, 4 -8

position loop, 6 -4, 6 -25

position loop gain, 6 -15, 6 -16, 6 -26, 6 -30, 6 -32
 setting, 6 -7

position reference, 5 -15

positioning, high-speed, 6 -6

positioning completed output signal, 5 -71

power loss, 5 -79

power supply
 harmonic suppression, 5 -117
 single-phase, specifications, 3 -29
 three-phase, specifications, 3 -31, 3 -33

proportional (P) control, 6 -10

proportional control, 6 -8

proportional/integral (PI) control, 6 -10

protective sequence, 5 -68

PSO serial data, specifications, 5 -99

pulse control (pulse train reference), 5 -58

pulse divider, setting the, 5 -23

pulse dividing ratio, setting the, 5 -100

R

radial load, Servomotors, 2 -4

reception sequence, 5 -97

reference input circuits, 3 -24

reference input line, noise, 5 -110

reference offset, adjustment, 5 -60, 6 -4

reference position input circuit, 3 -24

reference pulse counter monitor display, 7 -19

reference pulse form, selecting, 5 -17

reference pulse input signal, timing, 5 -19

reference speed input, 3 -24

reference torque input, 3 -24

reference voltage, offset, 6 -4

regenerative energy, calculating, 5 -86

regenerative overload signal, 5 -76

regenerative resistors
 built-in, 5 -80
 calculating capacity, 5 -84
 connecting, 5 -82
 external, 5 -81

response characteristics, 6 -30

responsiveness, 6 -26, 6 -30

Reverse Rotation Mode, 5 -4
 setting the, 5 -4

reverse rotation prohibited signal, 7 -23, 7 -38

rigidity, 6 -32

running output signal, 5 -74

S

SEN signal, 5 -75, 5 -93, 5 -101

sequence I/O signal monitor display, 7 -17

sequence I/O signals, 5 -24

sequence input circuit interface, 3 -25

Serial Encoders, 1 -4

servo alarm
 outputs, 5 -68
 resetting, 7 -4

servo gain, 6 -16
 adjusting, 6 -25
 setting, 6 -6
 user constants, 6 -25

Servo ON input signal, 5 -70

Servo Ready output signal, 5 -75

servo system block diagram, 6 -25

Servomotor Stop Mode, 5 -6

Servomotors, 1 -2, 2 -2
 handling oil and water, 2 -6
 inspection, 9 -2
 installation site, 2 -3
 product part names, 1 -8
 ratings, 8 -2
 rotation direction, 7 -25
 setting rotation direction, 5 -34
 SGMAH dimensional drawings, 8 -6
 SGMAH ratings and specifications, 8 -2
 SGMAH torque and motor speed, 8 -4
 SGMDH dimensional drawings, 8 -24
 SGMDH ratings and specifications, 8 -22
 SGMDH torque and motor speed, 8 -23
 SGMGH dimensional drawings, 8 -14, 8 -18
 SGMGH ratings and specifications, 8 -10, 8 -15
 SGMGH torque and motor speed, 8 -12, 8 -16
 SGMPH dimensional drawings, 8 -9
 SGMPH ratings and specifications, 8 -7
 SGMPH torque and motor speed, 8 -8
 SGMSH dimensional drawings, 8 -21
 SGMSH ratings and specifications, 8 -19

- SGMSH torque and motor speed, 8 -20
 - shaft alignment, 2 -3
 - shaft load, 2 -4
 - storage temperature, 2 -2
 - switching rotation direction, 5 -4
 - winding resistance loss, 5 -87
 - Servopacks, 1 -6, 2 -7
 - absorbable energy, 5 -90
 - control panel, 2 -9
 - cooling, 2 -9
 - dimensional drawings, 8 -40
 - I/O signals, 3 -18
 - inspection, 9 -3
 - installation, 2 -9
 - installation site, 2 -8
 - internal block diagrams, 3 -7
 - online autotuning function, 6 -16
 - operating conditions, 9 -3
 - orientation, 2 -8
 - output circuits, 3 -25
 - power loss, 3 -15
 - product part names, 1 -9
 - ratings, 8 -33
 - Reverse Rotation Mode, 5 -4
 - setting up the SGDM, 5 -48
 - specifications, 8 -28
 - standard connection examples, 3 -29
 - stopping, 5 -60
 - storage conditions, 2 -7
 - user constants, 5 -48
 - wiring to encoders, 3 -27
 - shaft alignment, Servomotors, 2 -3
 - shaft load, Servomotors, 2 -4
 - signals
 - /ALM-RST, 5 -69
 - /BK, 5 -67
 - /CLT, 5 -10
 - /COIN, 5 -71, 5 -77
 - /N-CL, 5 -12
 - /NEAR, 5 -77
 - /P-CL, 5 -12
 - /P-CON, 5 -34, 5 -40, 5 -47
 - /S-RDY, 5 -75
 - /TGON, 5 -74
 - /V-CMP, 5 -72
 - /WARN, 5 -76
 - absolute, 5 -97
 - analog, 3 -24
 - analog monitor, 6 -33
 - forward rotation prohibited, 7 -23, 7 -38
 - I/O connections, 3 -19
 - photocoupler output, 5 -68
 - reverse rotation prohibited, 7 -23, 7 -38
 - SEN, 5 -75, 5 -93, 5 -101
 - Servo ON, 5 -70
 - smoothing capacitor, 5 -80
 - smoothing function, 6 -3
 - soft start function, 6 -2
 - software version, checking the, 7 -37
 - specifications
 - SGMAH Servomotors, 8 -2
 - SGMDH Servomotors, 8 -22
 - SGMGH Servomotors, 8 -10, 8 -15
 - SGMPH Servomotors, 8 -7
 - SGMSH Servomotors, 8 -19
 - speed bias, 6 -9
 - speed coincidence output, 5 -72
 - speed control, 6 -32
 - adjusting manually, 6 -27
 - principle of, 5 -42
 - speed control (analog reference), 5 -58, 5 -59
 - Speed Control Mode, 3 -37
 - trial operation, 4 -7
 - speed feed-forward function, 5 -43
 - speed feedback compensation, 6 -13, 6 -23
 - speed loop, 6 -17, 6 -25
 - speed loop gain, 6 -15, 6 -16, 6 -29
 - setting, 6 -6
 - speed loop integral time constant, 6 -29
 - speed reference, 5 -13, 6 -9, 6 -11, 6 -26
 - speed reference input gain, 6 -28
 - speed reference offset, manual adjustment, 7 -28
 - standard Servopack connections, examples, 3 -29
 - storage conditions, Servopacks, 2 -7
 - switches, and factory settings, B -6
- ## T
- single-phase power supply, specifications, 3 -29
 - three-phase power supply, specifications, 3 -31, 3 -33
 - thrust load, Servomotors, 2 -4
 - torque control, using, 5 -36
 - torque control (analog reference), 5 -58, 5 -59
 - Torque Control Mode, 3 -39, 6 -17
 - torque feed forward function, 6 -17
 - torque feed-forward function, 5 -42
 - torque limiting, by analog voltage reference
 - function 1, 5 -44
 - function 2, 5 -45
 - torque limits, 5 -7, 5 -9
 - external, 5 -11
 - torque reference filter, time constant, 6 -5, 6 -25
 - torque reference filter time constant, 6 -28, 6 -29
 - torque reference inputs, 5 -39, 6 -11
 - torque reference offset, manual adjustment, 7 -30

torsion resonance, 6 -28
transmission sequence, 5 -98
trial operation
 in Position Control Mode, 4 -8
 in Speed Control Mode, 4 -7
 input signals, 4 -12
 Servomotor without load, 4 -3
 two-step, 4 -2
 user constants, 4 -12
 using reference input, 4 -7
troubleshooting, 9 -1, 9 -5
 with alarm display, 9 -5
 with no alarm display, 9 -32
two-step trial operation, 4 -2

U

undershooting, 6 -10
user constants, 5 -48
 configuration, 5 -3
 function selection, 7 -10

initializing settings, 7 -40
 list of, B -2
 numbers, 7 -9
 setting from host controller, 5 -13

W

warning displays, 9 -36
warning output signal, 5 -76
winding resistance loss, 5 -87
wiring, 5 -105
 Servopacks to encoders, 3 -27
wiring example, 3 -14
wiring precautions, 3 -12, 5 -105

Z

zero clamp, 5 -59, 5 -62
 conditions, 5 -63



Σ-II Series SGM□H/SGDH

USER'S MANUAL

Design and Maintenance

TOKYO OFFICE

New Pier Takeshiba South Tower, 1-16-1, Kaigan, Minatoku, Tokyo 105-6891 Japan
Phone 81-3-5402-4511 Fax 81-3-5402-4580

YASKAWA ELECTRIC AMERICA, INC.

2121 Norman Drive South, Waukegan, IL 60085, U.S.A.
Phone 1-847-887-7000 Fax 1-847-887-7370

MOTOMAN INC. HEADQUARTERS

805 Liberty Lane West Carrollton, OH 45449, U.S.A.
Phone 1-937-847-6200 Fax 1-937-847-6277

YASKAWA ELÉTRICO DO BRASIL COMÉRCIO LTDA.

Avenida Fagundes Filho, 620 Bairro Saude-Sao Paulo-SP, Brazil CEP: 04304-000
Phone 55-11-5071-2552 Fax 55-11-5581-8795

YASKAWA ELECTRIC EUROPE GmbH

Am Kronberger Hang 2, 65824 Schwalbach, Germany
Phone 49-6196-569-300 Fax 49-6196-868-301

Motoman Robotics Europe AB

Box 504 S38525 Torsås, Sweden
Phone 46-486-48800 Fax 46-486-41410

Motoman Robotec GmbH

Kammerfeldstraße 1, 85391 Allershausen, Germany
Phone 49-8166-900 Fax 49-8166-9039

YASKAWA ELECTRIC UK LTD.

1 Hunt Hill Orchardton Woods Cumbernauld, G68 9LF, United Kingdom
Phone 44-1236-735000 Fax 44-1236-458182

YASKAWA ELECTRIC KOREA CORPORATION

Klpa Bldg #1201, 35-4 Youido-dong, Yeongdungpo-Ku, Seoul 150-010, Korea
Phone 82-2-784-7844 Fax 82-2-784-8495

YASKAWA ELECTRIC (SINGAPORE) PTE. LTD.

151 Lorong Chuan, #04-01, New Tech Park Singapore 556741, Singapore
Phone 65-282-3003 Fax 65-289-3003

YASKAWA ELECTRIC (SHANGHAI) CO., LTD.

4F No.18 Aona Road, Waigaoqiao Free Trade Zone, Pudong New Area, Shanghai 200131, China
Phone 86-21-5866-3470 Fax 86-21-5866-3869

YATEC ENGINEERING CORPORATION

Shen Hsiang Tang Sung Chiang Building 10F 146 Sung Chiang Road, Taipei, Taiwan
Phone 886-2-2563-0010 Fax 886-2-2567-4677

YASKAWA ELECTRIC (HK) COMPANY LIMITED

Rm. 2909-10, Hong Kong Plaza, 186-191 Connaught Road West, Hong Kong
Phone 852-2803-2385 Fax 852-2547-5773

BEIJING OFFICE

Room No. 301 Office Building of Beijing International Club, 21
Jianguomenwai Avenue, Beijing 100020, China
Phone 86-10-6532-1850 Fax 86-10-6532-1851

TAIPEI OFFICE

Shen Hsiang Tang Sung Chiang Building 10F 146 Sung Chiang Road, Taipei, Taiwan
Phone 886-2-2563-0010 Fax 886-2-2567-4677

SHANGHAI YASKAWA-TONGJI M & E CO., LTD.

27 Hui He Road Shanghai China 200437
Phone 86-21-6531-4242 Fax 86-21-6553-6060

BEIJING YASKAWA BEIKE AUTOMATION ENGINEERING CO., LTD.

30 Xue Yuan Road, Haidian, Beijing P.R. China Post Code: 100083
Phone 86-10-6233-2782 Fax 86-10-6232-1536

SHOUGANG MOTOMAN ROBOT CO., LTD.

7, Yongchang-North Street, Beijing Economic Technological Investment & Development Area,
Beijing 100076, P.R. China
Phone 86-10-6788-0551 Fax 86-10-6788-2878



YASKAWA

YASKAWA ELECTRIC CORPORATION

Specifications are subject to change without notice
for ongoing product modifications and improvements.