

■ XW2B-20J6-1B

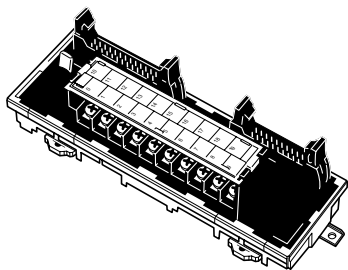

This Servo Relay Unit connects to the following OMRON Position Control Units. Communications are not supported.

- CS1W-NC113/-NC133
- CJ1W-NC113/-NC133
- C200HW-NC113
- C200H-NC112
- 3F88M-DRT141

● External Dimensions

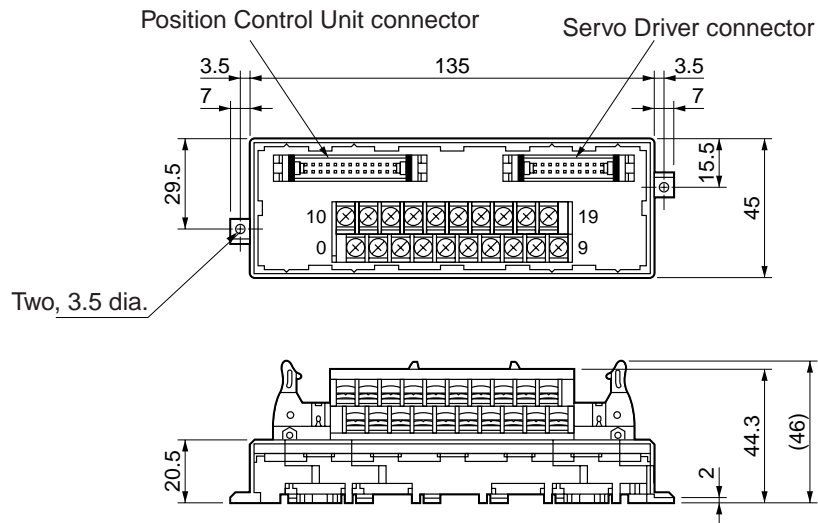

Note Terminal Block pitch: 7.62 mm

● Wiring

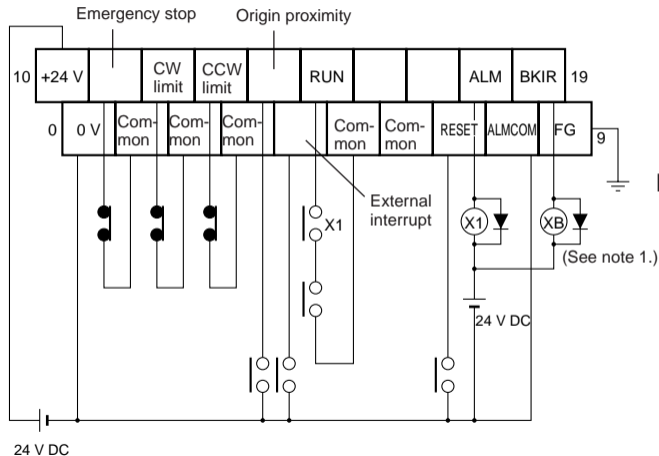

- Note**
1. The XB contact is used to turn ON/OFF the electromagnetic brake.
 2. Do not connect unused terminals.
 3. The 0 V terminal is internally connected to the common terminals.
 4. The following crimp terminal is applicable: R1.25-3 (round with open end).