

## SRT2-ID32ML

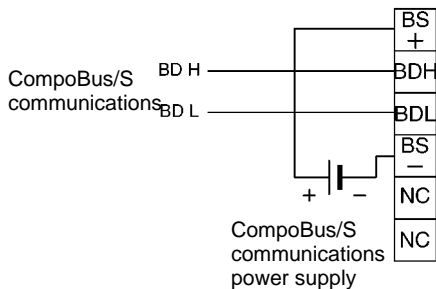

## SRT2-ID32ML-1

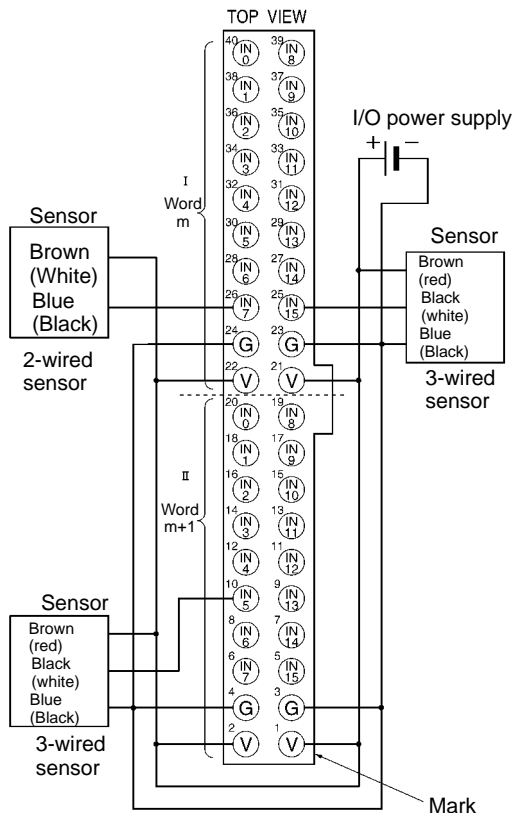
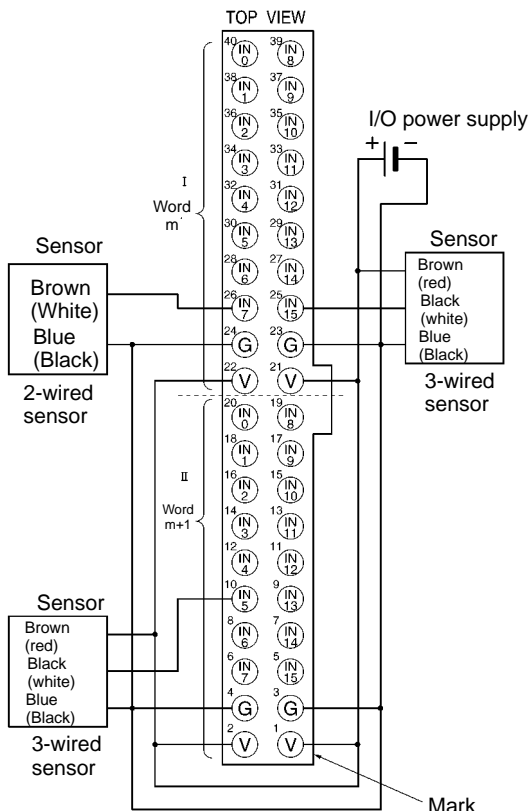
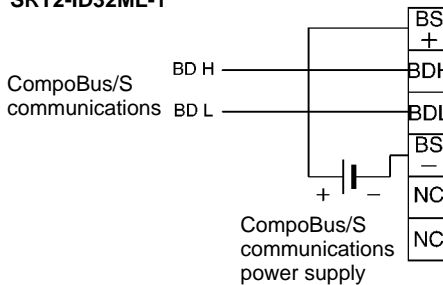

- Note**
1. The V terminals are all connected internally, as are the G terminals.
  2. In accordance with the changes in the standards for photoelectric sensors and proximity sensors, wire colors have been changed. Colors in parentheses are the old wire colors.