

CN1

I/O word "n"

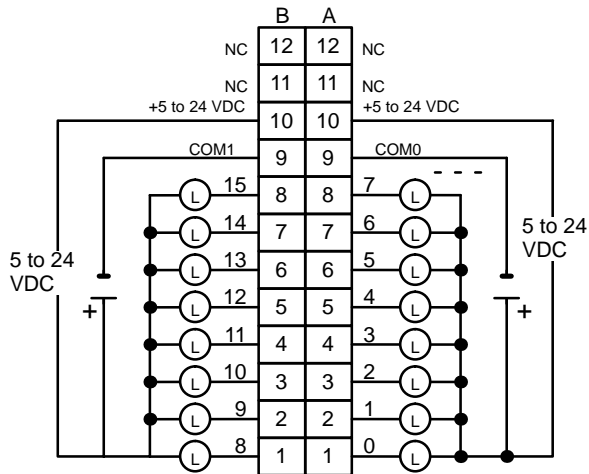

CN2

I/O word "n+1"

