

CN1

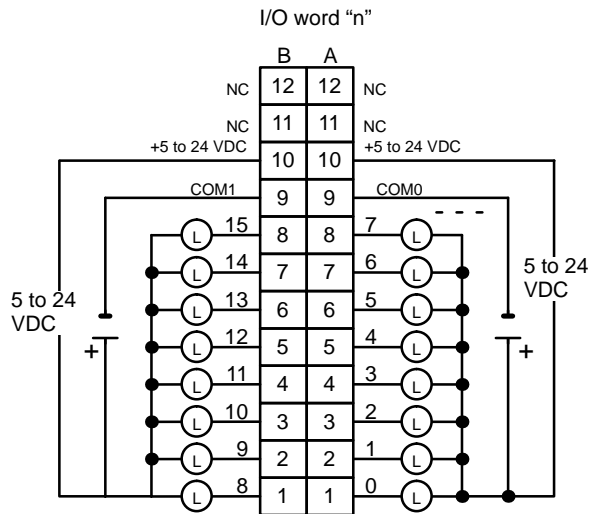

CN2

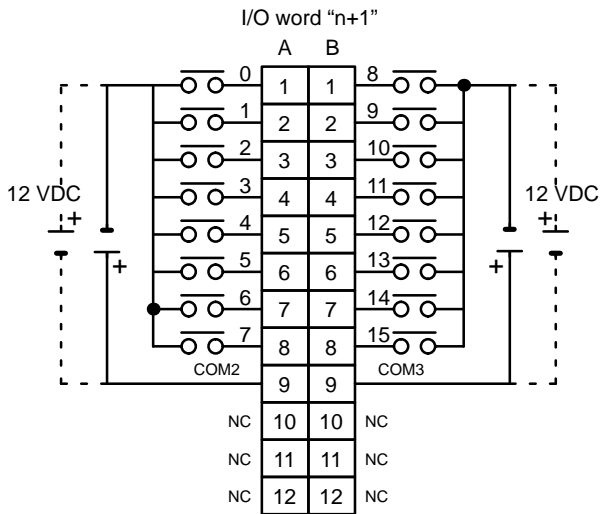

- Note**
1. I/O word "n" is determined by the unit number setting ($n = \text{CIO } 2000 + 10 \times \text{unit number}$).
 2. The Unit will have 16 static output and 16 static input points when pin 1 of its DIP switch is OFF.
 3. When pin 2 of the Unit's DIP switch is ON, input points 08 to 15 in connector B are high-speed inputs.
 4. The user is not authorized to change the fuse.