

Cat. No. W357-E1-1

**CQM1-ARM21**

**AS-Interface<sup>®</sup> Master Unit**

**OPERATION MANUAL**

**OMRON**







**CQM1-ARM21**



# **AS-Interface<sup>®</sup> Master Unit**

## **Operation Manual**



*Produced April 1999*



## **Notice:**

OMRON products are manufactured for use according to proper procedures by a qualified operator and only for the purposes described in this manual.

The following conventions are used to indicate and classify precautions in this manual. Always heed the information provided with them. Failure to heed precautions can result in injury to people or damage to the product.

-  **DANGER!** Indicates information that, if not heeded, is likely to result in loss of life or serious injury.
-  **WARNING** Indicates information that, if not heeded, could possibly result in loss of life or serious injury.
-  **Caution** Indicates information that, if not heeded, could result in relatively serious or minor injury, damage to the product, or faulty operation.

## **OMRON Product References**

All OMRON products are capitalised in this manual. The word “Unit” is also capitalised when it refers to an OMRON product, regardless of whether or not it appears in the proper name of the product.

The abbreviation “Ch,” which appears in some displays and on some OMRON products, often means “word” and is abbreviated “Wd” in documentation in this sense.

The abbreviation “PLC” means Programmable Logic Controller and is not used as an abbreviation for anything else.

## **Visual Aids**

The following headings appear in the left column of the manual to help you locate different types of information.

**Note** Indicates information of particular interest for efficient and convenient operation of the product.

**1, 2, 3...**Indicates lists of one sort or another, such as procedures, checklists, etc.

## **© OMRON, 1999**

All rights reserved. No part of this publication may be reproduced, stored in a retrieval system, or transmitted, in any form, or by any means, mechanical, electronic, photocopying, recording, or otherwise, without the prior written permission of OMRON.

No patent liability is assumed with respect to the use of the information contained herein. Moreover, because OMRON is constantly striving to improve its high-quality products, the information contained in this manual is subject to change without notice. Every precaution has been taken in the preparation of this manual. Nevertheless, OMRON assumes no responsibility for errors or omissions. Neither is any liability assumed for damages resulting from the use of the information contained in this publication.





# TABLE OF CONTENTS

<b>PRECAUTIONS .....</b>	<b>xi</b>
1 Intended Audience .....	xii
2 General Precautions .....	xii
3 Safety Precautions .....	xii
4 Operating Environment Precautions .....	xii
5 Application Precautions .....	xiii
6 EC Directives .....	xiv
<b>1 AS-INTERFACE .....</b>	<b>1</b>
1-1 Introduction .....	2
1-2 Master Functionality .....	7
1-3 Slave Functionality .....	8
<b>2 INSTALLATION .....</b>	<b>9</b>
2-1 Physical Layout of the Unit .....	10
2-2 Mounting the CQM1-ARM21 .....	14
2-3 AS-Interface Network Installation .....	15
<b>3 SPECIFICATIONS AND PERFORMANCE .....</b>	<b>17</b>
3-1 Overall Specifications .....	18
3-2 Dimensions .....	19
3-3 Performance .....	19
<b>4 PLC INTERFACE .....</b>	<b>25</b>
4-1 PLC Settings .....	26
4-2 Internal Data Structures .....	27
4-3 Master Operation Modes .....	28
4-4 AS-Interface Standard Modes .....	31
4-5 Setup Mode .....	34
<b>5 SYSTEM CONFIGURATION .....</b>	<b>49</b>
5-1 AS-Interface Set-up Methods .....	50
5-2 Bottom-up Method .....	50
5-3 Top-down Method .....	51
<b>6 TROUBLESHOOTING AND MAINTENANCE .....</b>	<b>53</b>
6-1 Error indicators .....	54
6-2 Troubleshooting .....	54
6-3 Maintenance .....	58
<b>7 APPENDICES .....</b>	<b>59</b>
Appendix A AS-Interface PICS .....	60
Appendix B AS-Interface Slave Profiles .....	63
Appendix C AS-Interface terminology and abbreviations .....	64
<b>Index .....</b>	<b>67</b>
<b>Revision History .....</b>	<b>69</b>



## ***About this Manual:***

This manual describes the installation and operation of the AS-Interface Master Unit and includes the sections described below.

Please read this manual carefully and be sure you understand the information provided before attempting to install and operate the AS-Interface Master Unit. **Be sure to read the precautions provided in the following section.**

**Section 1** gives a brief description of AS-Interface.

**Section 2** describes the installation of the CQM1-ARM21.

**Section 3** describes the overall specifications and the communication performance of the Unit.

**Section 4** describes the interface with the user.

**Section 5** describes how to set up an AS-Interface network.

**Section 6** describes the troubleshooting procedures and maintenance operations.



### **WARNING**

Failure to read and understand the information provided in this manual may result in personal injury or death, damage to the product, or product failure. Please read each section in its entirety and be sure you understand the information provided in the section and related sections before attempting any of the procedures or operations given.



# PRECAUTIONS

This section provides general precautions for using the AS-Interface Master Units, Programmable Controllers, and related devices.

**The information contained in this section is important for the safe and reliable application of the AS-Interface Master Units. You must read this section and understand the information contained before attempting to set up or operate an AS-Interface Master Unit and PLC system.**

1	Intended Audience .....	xii
2	General Precautions .....	xii
3	Safety Precautions .....	xii
4	Operating Environment Precautions .....	xii
5	Application Precautions.....	xiii
6	EC Directives.....	xiv

## 1 Intended Audience

This manual is intended for the following personnel, who must also have knowledge of electrical systems (an electrical engineer or the equivalent).

- Personnel in charge of installing FA systems.
- Personnel in charge of designing FA systems.
- Personnel in charge of managing FA systems and facilities.

## 2 General Precautions

The user must operate the product according to the performance specifications described in the operation manuals.

Before using the product under conditions which are not described in the manual or applying the product to nuclear control systems, railroad systems, aviation systems, vehicles, combustion systems, medical equipment, amusement machines, safety equipment, and other systems, machines, and equipment that may have a serious influence on lives and property if used improperly, consult your OMRON representative.

Make sure that the ratings and performance characteristics of the product are sufficient for the systems, machines, and equipment, and be sure to provide the systems, machines, and equipment with double safety mechanisms.

This manual provides information for installing and operating OMRON AS-Interface Master Units. Be sure to read this manual before operation and keep this manual close at hand for reference during operation.

 **WARNING** It is extremely important that a PLC and all PLC Units be used for the specified purpose and under the specified conditions, especially in applications that can directly or indirectly affect human life. You must consult with your OMRON representative before applying a PLC system to the above mentioned applications.

## 3 Safety Precautions

 **WARNING** Never attempt to disassemble any Units while power is being supplied. Doing so may result in serious electrical shock or electrocution.

 **WARNING** Never touch any of the terminals while power is being supplied. Doing so may result in serious electrical shock or electrocution.

## 4 Operating Environment Precautions

Do not operate the control system in the following places.

- Where the PLC is exposed to direct sunlight.
- Where the ambient temperature is below 0°C or over 55°C.
- Where the PLC may be affected by condensation due to radical temperature changes.
- Where the ambient humidity is below 10% or over 90%.

- Where there is any corrosive or inflammable gas.
- Where there is excessive dust, saline air, or metal powder.
- Where the PLC is affected by vibration or shock.
- Where any water, oil, or chemical may splash on the PLC.

 **Caution** The operating environment of the PLC System can have a large effect on the longevity and reliability of the system. Improper operating environments can lead to malfunction, failure, and other unforeseeable problems with the PLC System. Be sure that the operating environment is within the specified conditions at installation and remains within the specified conditions during the life of the system.

## 5 Application Precautions

Observe the following precautions when using the AS-Interface Master Units or the PLC.

 **WARNING** Failure to abide by the following precautions could lead to serious or possibly fatal injury. Always heed these precautions.

- Always ground the system to 100  $\Omega$  or less when installing the system to protect against electrical shock.
- Always turn OFF the power supply to the PLC before attempting any of the following. Performing any of the following with the power supply turned ON may lead to electrical shock:
  - Mounting or removing any Units (e.g., I/O Units, CPU Unit, etc.) or memory cassettes.
  - Assembling any devices or racks.
  - Connecting or disconnecting any cables or wiring.

 **Caution** Failure to abide by the following precautions could lead to faulty operation of the PLC or the system or could damage the PLC or PLC Units. Always heed these precautions.

- Use the Units only with the power supplies and voltages specified in the operation manuals. Other power supplies and voltages may damage the Units.
- Take measures to stabilise the power supply to conform to the rated supply if it is not stable.
- Provide circuit breakers and other safety measures to provide protection against shorts in external wiring.
- Do not apply voltages exceeding the rated input voltage to Input Units. The Input Units may be destroyed.
- Do not apply voltages exceeding the maximum switching capacity to Output Units. The Output Units may be destroyed.
- Always disconnect the LG terminal when performing withstand voltage tests.
- Install all Units according to instructions in the operation manuals. Improper installation may cause faulty operation.
- Provide proper shielding when installing in the following locations:
  - Locations subject to static electricity or other sources of noise.
  - Locations subject to strong electromagnetic fields.
  - Locations subject to possible exposure to radiation.
  - Locations near power supply lines.

- Be sure to tighten Backplane screws, terminal screws, and cable connector screws securely.
- Do not attempt to take any Units apart, to repair any Units, or to modify any Units in any way.

 **Caution** The following precautions are necessary to ensure the general safety of the system. Always heed these precautions.

- Provide double safety mechanisms to handle incorrect signals that can be generated by broken signal lines or momentary power interruptions.
- Provide external interlock circuits, limit circuits, and other safety circuits in addition to any provided within the PLC to ensure safety.

## **6 EC Directives**

The AS-Interface Master Units that meet EC directives also meet the common emission standard (EN50081-2). When AS-Interface Master Units are built into equipment, however, the measures necessary to ensure that the standard is met will vary with the overall configuration, the other devices connected, and other conditions. You must therefore confirm that EC directives are met for the overall machine or device.



# 1 AS-Interface

This section provides a general introduction to AS-Interface

1-1	Introduction.....	2
1-1-1	<i>AS-International</i> .....	2
1-1-2	<i>System Components</i> .....	3
1-1-3	<i>Technical Details</i> .....	4
1-2	Master Functionality.....	7
1-3	Slave Functionality.....	8

## 1-1 Introduction

This chapter will provide a brief introduction into AS-Interface®.

For more detailed information, refer to:

AS-International Association  
Auf dem Broich 4a,  
D 51519 Odenthal  
Germany  
Tel: +49 2174 40756  
Fax: +49 2174 41571

### 1-1-1 AS-International



A consortium of European companies started work on the definition of a simple, low-cost industrial bus system in 1990. After successfully completing this work in 1993, the consortium was dissolved.

The technology of AS-Interface is now owned and administered by AS-International, who have responsibility for marketing on behalf of the members, and evolving the technology as directed by an executive of vendor companies.

AS-Interface technology has been submitted for approval under the proposed IEC 947 standard.

User Groups with currently some 80 members are established in eight European countries, North America and Japan. Over 200 products are now available from 30+ vendors.

OMRON is a full member of the AS-International Association.

#### Positioning

AS-Interface is primarily aimed at the transfer of binary in- and output data in industrial applications. It can be seen as a direct replacement for traditional cable trees. The main advantages of AS-Interface over traditional wiring methods are:

- Power supply and communication are combined in one cable.
- Reduction of cabling and installation work.
- Improved troubleshooting and maintenance.

Sensors and actuators with a built-in AS-Interface slave chip can be connected directly to the AS-Interface line. Other, conventional devices can be connected via AS-Interface slave units with general purpose in- and outputs.

AS-Interface should be seen as complementary to higher level fieldbuses, which provide sophisticated performance at higher cost. Via gateways, entire AS-Interface systems can be linked transparently as slaves to most available higher level open fieldbus systems, such as CompoBus/D (DeviceNet) or PROFIBUS-DP.

#### Application areas

AS-Interface is widely used in e.g. machine control, transport, packaging, and warehouse applications.

## 1-1-2 System Components

### Master

AS-Interface is a single master - multi slave system. The system requires one master unit to control all data exchanges over the bus. During normal operation, the master cyclically sends output data to all slaves, and receives the slaves' input data in return.

Apart from the cyclic data exchange, the master will search the bus for newly added slave units, and may send out a specific command to one slave per bus cycle.

The maximum number of slaves that an AS-Interface master can exchange I/O data with at any time is 31.

### Slave

AS-Interface slaves will only respond to master requests containing the address that they have been set to. Practically all AS-Interface slaves have their address stored in non-volatile memory. The factory setting is always to address 0. The address can be changed either by a hand-held addressing tool, or by a specific master request.

Each slave may have up to 4 bits input plus 4 bits output data, and up to 4 parameter bits. Each I/O combination allowed by the AS-Interface specification has a unique identification code, which is stored in the slave, and can be read by the master.

In a fully extended AS-Interface network, the maximum amount of digital I/O points can be  $31 * (4 \text{ inputs} + 4 \text{ outputs}) = 248$ .

The slave's circuitry is generally powered via the AS-Interface line, but in- and output ports may have a provision for external power supply.

### Power Supply

Superimposing communication data on the lines that supply energy to the slaves creates special requirements for an AS-Interface power supply unit. A station will communicate by varying its impedance on the AS-Interface line, thereby generating specifically shaped pulses in the current drawn from the line.

### Data decoupling

The data decoupling circuit incorporated in the AS-Interface power supply will transform these current pulses into voltage variations, which can be detected by the other stations on the line. In order to allow the whole system to work reliably, the voltage, current range and impedance of an AS-Interface power supply must be within the limits specified by the AS-Interface standard.

An AS-Interface power supply should have a minimum rated output current of 2.4 A at a supply voltage of 29.5...31.6V DC.

### Cable

Although AS-Interface recommends the use of the trademark 'yellow cable' especially designed for IP67 protection and on-line addition and removal of slaves, any shielded or unshielded two-wire cable may be used that meets the following specifications (at a frequency of 167 kHz).

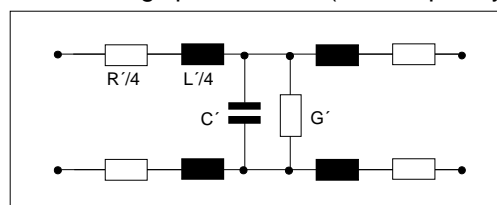

$$Z : 70 \dots 140 \Omega$$

$$R' : < 90 \text{ m}\Omega/\text{m}$$

$$L' : 400 \dots 1300 \text{ nH}/\text{m}$$

$$C' : < 80 \text{ pF}/\text{m}$$

$$G' : < 5 \text{ }\mu\text{S}/\text{m}$$

The recommended cross section is  $2 \times 1.5 \text{ mm}^2$ ; The maximum allowed current through the AS-Interface cable is 8A.

**No termination**

The network topology may be a star, a line with or without branch lines, or a full tree structure. Termination is not required.

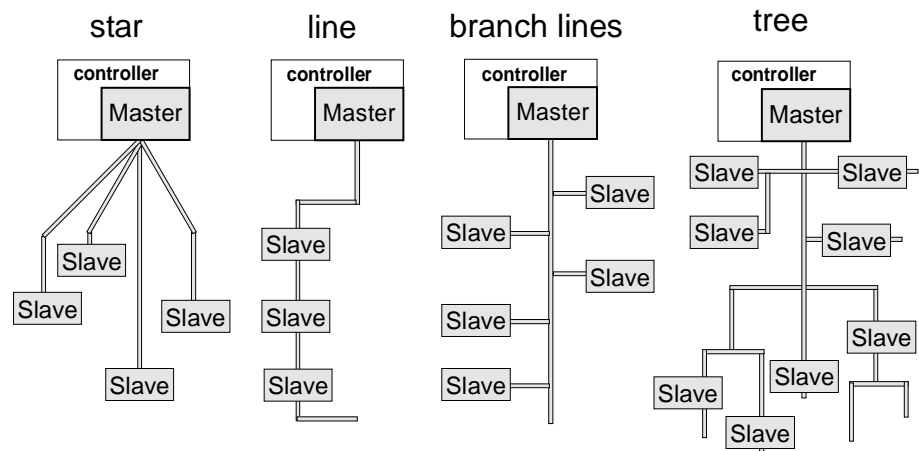

The maximum cable length for the total system may not exceed 100 m. By using 2 repeaters and additional AS-Interface power supplies, this can be extended to up to 300 m.

**1-1-3 Technical Details**

This section will provide some technical details of the AS-Interface system. It is not essential to understand all details in order to operate the CQM1-ARM21.

**Concept**

The aim of AS-Interface is to supply energy to, AND exchange I/O data with slave stations over a simple unshielded two-wire cable. To achieve this, while maintaining reliability and electromagnetic compatibility in an industrial environment, a specific communication model has been developed which ensures encoding without a DC signal component and a very narrow power spectrum.

- Messages are encoded in Manchester II format.
- Modulation is by alternate pulse modulation (APM).
- The transmitter, in both master and slave, acts as a current sink generating sine-shaped pulses.
- The characteristic impedance of the power supply unit transforms each current pulse into a  $\sin^2$ -shaped voltage pulse.
- One bit time ( $T_{\text{Bit}}$ ) is defined as  $6 \mu\text{s}$ , resulting in a bit sequence frequency of 166.67 kbit/s.

**Communication principles**

All communication on the AS-Interface line is controlled by the master. The AS-Interface specification prescribes in detail which sequence of actions the master must follow. On the highest level, the execution control is managed as shown below:

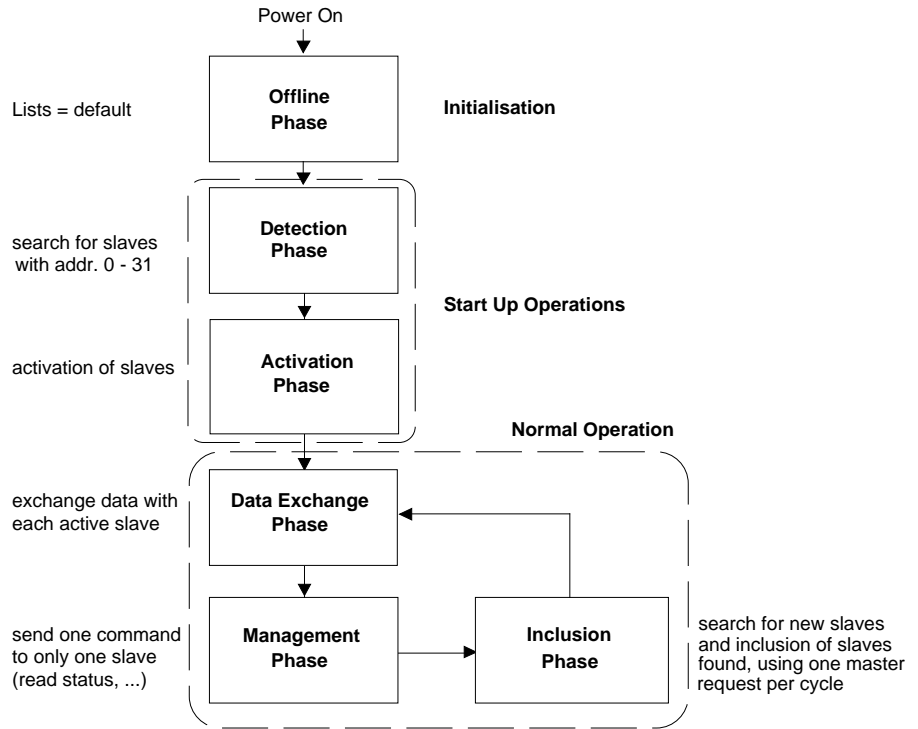

**Request**

All requests, sent by the master and received by the slave in any phase, have a fixed format. They are composed of the following elements:

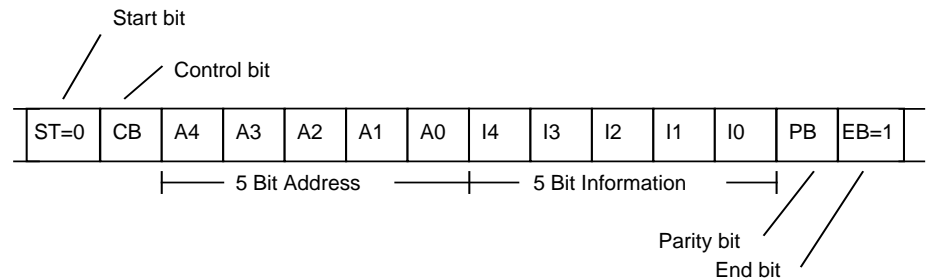

**Response**

After each master request, the master will wait for a response from the targeted slave. The responses sent by the slaves have no control bit and no address, and are always composed as shown below:

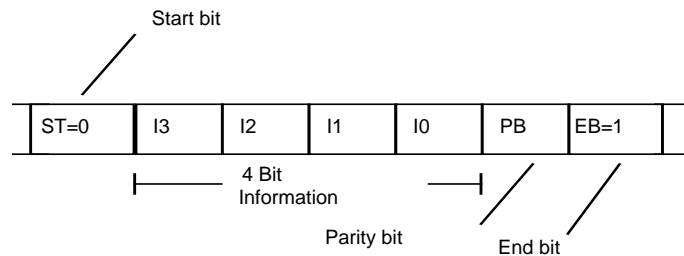

In normal operation, master requests and slave responses will alternate on the bus. If a slave cannot execute the master request, it will not respond to the request. If no slave response is detected within 10 bit times, the master will send the next master request to ensure a constant poll cycle for all active slaves.

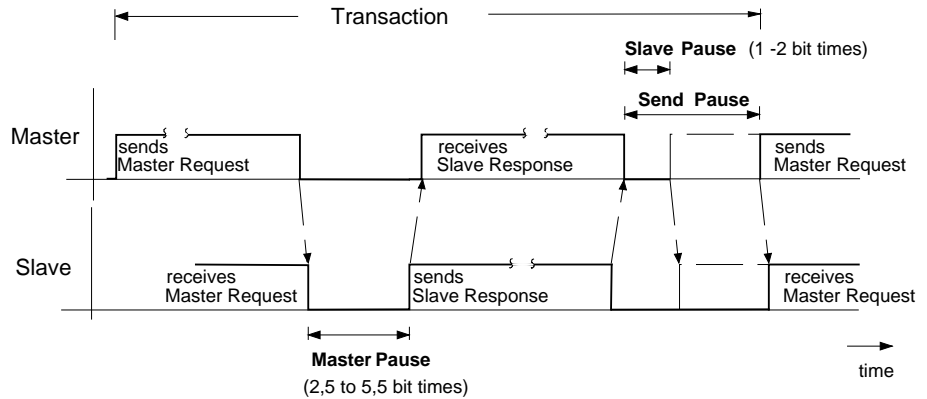

**Security**

A request or response will be judged invalid if it contains one of the following types of error:

- Start bit error**      The initial pulse is not negative.
- Alternating error**    Two consecutive pulses do not have different polarity.
- No information**        Pulses are not detected in periods of  $(n * 6)_{-0,5}^{+1,0} \mu s$ .
- Parity error**          The sum of all information bits is not even.
- End bit error**         The last pulse is not positive.
- Length error**         Pulses are detected during the master or slave pause.

Upon an invalid or missing slave response, a master station will retry to access the slave. If this fails, the slave will be taken out of the list of active slaves. The master will cyclically try to re-initialise the slave in the inclusion phase.

**Performance**

The cycle time of an AS-Interface network depends on the number of slaves that the master has to exchange I/O data with. The AS-Interface specification defines the maximum bus cycle time as follows:

$$\begin{array}{rcl}
 & & \text{if } n = 33 \\
 n * \text{Master request} & = n * (14 \text{ Bit}) = n * 84 \mu s & = 2722 \mu s \\
 + n * \text{Master pause} & = n * (3 \text{ Bit}) = n * 18 \mu s \text{ (synchr. slave)} & = 594 \mu s \\
 + n * \text{Slave response} & = n * (7 \text{ Bit}) = n * 42 \mu s & = 1386 \mu s \\
 + n * \text{Send pause} & = n * (2 \text{ Bit}) = n * 12 \mu s \text{ (min.)} & = 396 \mu s \\
 \hline
 = T_{\text{cycle}} & = n * (26 \text{ Bit}) = n * 156 \mu s \text{ (min.)} & = 5148 \mu s
 \end{array}$$

where n is the number of all AS-Interface requests during data exchange in the AS-Interface cycle and in the inclusion phase, including one repetition. In normal operation, n will be the number of slaves plus 2.

With less than 31 slaves, the AS-Interface cycle time will be shorter. In principle, each slave less will decrease the cycle time by 156  $\mu s$ , but the master is allowed to lengthen the send pause up to 500  $\mu s$ , as long as the total cycle time does not exceed the stated maximum.

To calculate the CQM1-ARM21's cycle time, see 3-3, *Performance*.

## 1-2 Master Functionality

The master has a layered structure which is composed of three functional parts as shown in the following figure:

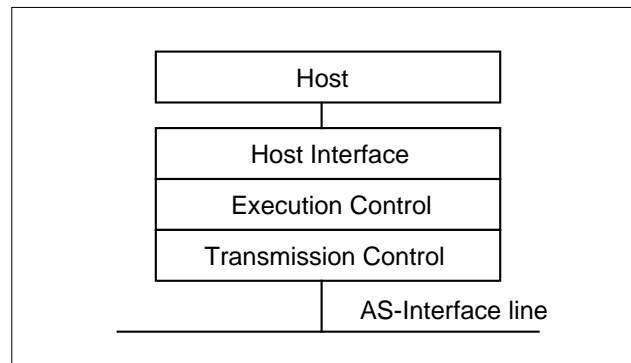

The AS-Interface specification defines the transmission control functions, and lists all mandatory and optional functions of the execution control. The host interface is in principle not governed by the AS-Interface specification.

### Master Profiles

Furthermore, three standard levels of compliance with the standard are defined in so-called master profiles. These are named M0, M1 and M2.

#### M0

The lowest level, the M0 or minimum master profile, defines the smallest set of mandatory functions. Any AS-Interface master should at least be able to execute these functions.

#### M1

The M1 or full master profile, provides all functions to fully configure an AS-Interface network, plus transfer of most internal status information to the host system.

#### M2

The M2 or reduced master profile consists of the M0 profile plus 2 additional functions to set and store slave parameters.

The CQM1-ARM21 provides M0 functionality in standard operation mode, but additional configuration functions are available in a special setup mode, in which the updating of slaves' I/O data in the PLC is partially suspended. In setup mode, the CQM1-ARM21 acts as a configuration tool.

All masters should, as a minimum, provide the following functionality:

- Cyclically read input data from slaves, and present this data to the host.
- Cyclically read output data from the host, and transmit this data to the slaves.
- Inform the host if the actual configuration matches the expected (projected) configuration.
- Offer two operation modes: protected mode and configuration mode.
- Store the actual configuration data (CDI) - detected in configuration mode - in non-volatile memory as the permanent configuration (PCD).

In protected mode, only slaves that are member of the list of projected slaves (LPS) and whose configuration data image (CDI) and permanent configuration data (PCD) are identical, will be activated.

In configuration mode, all detected slaves will be activated, irrespective of the differences in the values of the configuration data image (CDI) and permanent

configuration data (PCD) and independent of LPS.

A full list of the CQM1-ARM21's available functions is given in Appendix A, *AS-Interface PICS*.

## 1-3 Slave Functionality

### Slave Profiles

To allow an uncomplicated usage in standard applications, AS-Interface defines "profiles" for the slaves. In general a slave does not have a fixed meaning assigned to the I/O data and the parameter values, i.e., the specifications for the communication part do not restrict the usage of a slave to specific applications. However, it is the most important issue of the slave profiles to restrict the use of the data and parameter values for the most common applications, and to assign specific semantics to them.

In addition to the AS-Interface specifications, a profile contains all the additional definitions and restrictions needed for a slave in a specified application. The slave profile is independent of the vendor of the actuator, sensor, or other devices and elements. Thus, the profiles should help to increase the interchangeability of actuators and sensors.

A slave profile has a well defined and fixed:

- I/O configuration (I/O code) with well defined semantics for the I/O data and parameter values,
- identification code (ID code),
- definition of semantics of the levels high or low of the I/O data and parameters,
- list of minimum requirements on the physical realisation.

The ID code of the slave is used to distinguish between different slave profiles with the same I/O code. It is fixed to the slave during the assembling of the slave and is stored non-volatile and irreversible.

Defined slave profiles exist for:

- I/O=X ID=0 Remote I/O ports
- I/O=0 ID=1 Two dual-signal sensors
- I/O=1 ID=1 Single sensor with extended control
- I/O=7 ID=1 Interface for the transfer of 6 to 18-bit signals
- I/O=7 ID=2 Extended slave profile for the transmission of 6 to 21-bit signals
- I/O=B ID=1 Dual actuator with feedback
- I/O=D ID=1 Single actuator with monitoring

Virgin slave chips, before assembly at the manufacturer, have no particular configuration. They carry the I/O code =  $F_H$  and the ID code =  $F_H$ .



## 2 Installation

This section describes the Unit's external features, and how to install an AS-Interface system.

2-1 Physical Layout of the Unit .....	10
2-1-1 Front Cover.....	10
2-1-2 LED Indicators .....	11
2-1-3 Switches .....	12
2-1-4 Connector .....	14
2-2 Mounting the CQM1-ARM21 .....	14
2-3 AS-Interface Network Installation.....	15
2-3-1 AS-Interface Power Supply.....	15
2-3-2 AS-Interface Cable.....	15

## 2-1 Physical Layout of the Unit

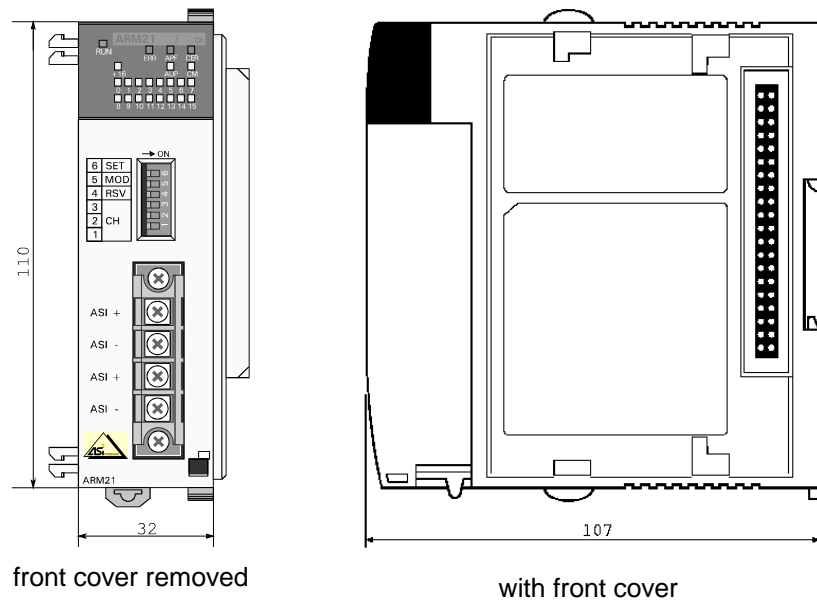

The CQM1-ARM21 is an AS-Interface master unit for OMRON's CQM1 range of programmable controllers. It can be mounted to any CPU type of the CQM1 series, within the restrictions for the number of I/O channels available in that CPU.

The dimensions of the CQM1-ARM21 are the same as those of comparable CQM1 I/O units. For mounting instructions, see the CQM1 Operation Manual.

The front of the unit features:

- A removable front cover.
- 23 LED indicators for unit status, bus status and slave status.
- 6 DIP switches for unit settings and AS-Interface configuration.
- A detachable connector for the AS-Interface cable.

### 2-1-1 Front Cover

To install the front cover onto the Master Unit, first slide the tabs on the top of the cover into the notches in the Master Unit (1) and then lock the cover into place by pressing the bottom of the cover into the Unit (2).

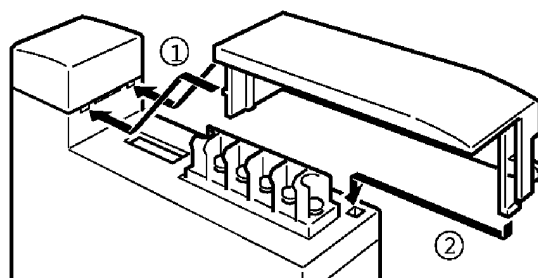

## 2-1-2 LED Indicators

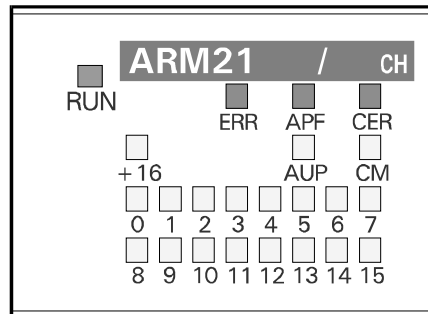

**RUN** (green) : Unit status indication.

ON : Indicates that the unit is receiving power from the CQM1 power supply, and that the unit has initialised properly.

Flashing : The unit is initialising.

**ERR** (red) : General error indication.

ON : An internal hardware problem is detected during power-on initialisation (RUN LED flashing).

Errors in the data transmission between slaves and the master.

A requested change of operation mode was not possible.

**APF** (red) : AS-Interface power fail indication.

ON : The supply voltage on the AS-Interface line is too low to guarantee reliable communication.

**CER** (red) : Configuration error.

ON : The detected actual configuration is different from the stored 'projected' configuration.

**AUP** (yellow) : Auto-programming is available.

ON : One slave is missing, and can be replaced by an identical slave with address 0, when the master is in Protected Mode. The address will then automatically be set to that of the missing slave.

**CM** (yellow) : ON : The unit is in Configuration Mode or in Setup Mode.

1. Configuration Mode.

The AS-Interface master will automatically accept new slaves in the configuration, and start I/O data exchange with them.

2. Setup Mode.

The permanent configuration data in the CQM1-ARM can be modified, slave addresses and slave parameters can be read/written.

OFF : the unit is in Protected Mode.

- 0~15** (yellow) : Slave status indicators.
  - ON : A slave is active, i.e. exchanging I/O data with the master.
  - Flash : A slave is in the list of projected slaves, but not active.
  - Slave 0 cannot be an active slave; if LED 0 flashes, a slave with address 0 has been detected on the network.
  
- +16** (yellow) : OFF : the status of slaves 0-15 is shown;  
 ON : the status of slaves 16-31 is shown.  
 If the setting of the CH switches 1-3 allows communication with more than 15 slaves, this indicator will periodically turn OFF and ON, to show the status of all slaves. If set to 15 or fewer slaves, this LED will remain OFF.

### 2-1-3 Switches

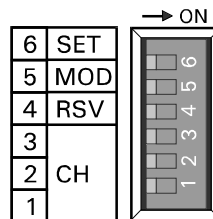

**CH** The switches 1-3 select the number of IR words that the CQM1-ARM21 will occupy in the CPU. This setting will influence the maximum number of AS-Interface slaves that can be addressed by the PLC, and therefore the maximum number of I/O points that can be connected.

SW3	SW2	SW1	IR words in + out	Highest AS-I slave address	Max. AS-I I/O points
OFF	OFF	OFF	3 + 3	11	44 / 44
OFF	OFF	ON	4 + 4	15	60 / 60
OFF	ON	-	6 + 6	23	92 / 92
ON	OFF	OFF	5 + 5	19	76 / 76
ON	OFF	ON	6 + 6	23	92 / 92
ON	ON	-	8 + 8	31	124 / 124

The master cannot address any slave beyond the highest AS-I slave address, in any operation mode.

Not every CQM1 CPU supports all possible switch settings. To determine the allowed settings, check the *CQM1/CPM1 Programming manual* (W228-E1) to verify the number of I/O points available to each CPU type, and take any additional I/O units to be mounted into consideration.

If the selected number of I/O words exceeds the maximum amount available in the CQM1 system, the CPU's RUN indicator will remain OFF, and an I/O UNIT OVER error will be indicated. Reduce the number of allocated I/O words or select a CPU type with larger I/O capacity. (See also 4-1, *PLC Settings*)

 **WARNING**

The CH switch settings should only be changed when the PLC power is OFF. Changing the positions of switches 1-3 while the PLC power is ON can result in an I/O BUS error in the CPU.

**RSV** Reserved. Keep this switch in OFF position.

**MOD** Selects the operation mode of the AS-Interface master.

OFF Configuration Mode / Setup Mode.

In Configuration Mode the AS-Interface master will exchange I/O data with any slave with a non-zero address on the network.

In Setup Mode, I/O data exchange between PLC CPU and ARM21 is partially suspended to allow configuration commands to be processed.

ON Protected Mode.

The AS-Interface master will only exchange I/O data with slaves that have been registered in the permanent configuration.

**SET** OFF → ON A change from OFF to ON stores the actual, detected configuration as permanent configuration data. The permanent configuration data consists of all active slaves' addresses, I/O codes, ID codes, and parameter data, and is stored in non-volatile memory (EEPROM) in the CQM1-ARM21.

This function is only available if the unit is *not* in Protected Mode, i.e. in Configuration Mode or Setup Mode (CM LED is ON). In Protected Mode, no specific action is performed.

ON → OFF : no specific action in any operation mode.

### 2-1-4 Connector

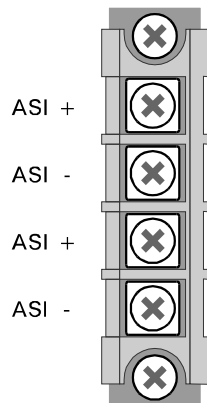

The Master Unit's terminal block can be removed from the Unit. To remove the terminal block, unscrew the screws at the top and bottom of the terminal block and pull it from the Unit. After wiring, attach the terminal block securely with the retaining screws to the specified tightening torque (approx. 0.4 N).

Both ASI + terminals will be connected to each other via the CQM1-ARM21, when the terminal block is attached to the unit. The same applies to the ASI - terminals.

The CQM1-ARM21 does not supply power to the AS-Interface cable. A separate AS-Interface power supply is required.

**⚠ Caution**

It is recommended to shut off the AS-Interface power supply to the Master Unit if the PLC power is turned off for a longer period of time.

## 2-2 Mounting the CQM1-ARM21

### Master Unit Installation

To use the Master Unit, connect it to a CQM1 PLC just like other Units such as I/O Units. Refer to the PLC's Operation Manual for details on mounting Units to the PLC or installing the PLC in a control panel.

**⚠ Caution**

A label is stuck to the Masters and Slaves to prevent pieces of wire from entering the Units. Install and wire the Units with the labels in place. Stray strands of wire could cause malfunctions. Be sure to remove the label after installation and wiring to facilitate cooling. The Units could overheat and malfunction if the labels aren't removed.

**⚠ Caution**

The Master Unit can be mounted on any CQM1-CPU. In principle, just one Master Unit can be connected to a PLC due to the limitation of the CPU's I/O areas.

Always mount the CQM1-ARM21 as the rightmost I/O Unit in a CQM1 system to reduce the amount of heat transferred to/from neighbouring I/O units.

When mounting additional I/O units to the CQM1 PLC system, check the total power consumption of the system, and select the appropriate power supply unit (See *CQM1 Operation Manual*, W226-E1).

The word addresses allocated in the PLC for the slaves' I/O data depend on the position of the Master Unit on the PLC. Refer to 4-1, *PLC Settings*, or the *CQM1 Programming Manual, W228-E1* for more details.

**End Cover**

After connecting the Master Unit, attach the End Cover to the Unit on the far right side of the PLC and attach the PLC to the DIN rail by locking the mounting pins onto the DIN track.

## 2-3 AS-Interface Network Installation

To complete an AS-Interface system, the following items are required, apart from the CQM1 PLC system with the CQM1-ARM21 Master Unit:

- AS-Interface Power Supply.
- AS-Interface Cable.
- AS-Interface Slaves:
  - general-purpose I/O slaves, and/or
  - sensors / actuators with integrated AS-Interface slave function.

A hand-held addressing device can be useful to build up the network, but is not essential, since the CQM1-ARM21 provides equivalent functionality when used in Setup Mode (See 4-5, *Setup Mode*)

### 2-3-1 AS-Interface Power Supply

Select an AS-Interface power supply that can provide sufficient power to support the Master Unit and all AS-Interface slaves to be connected to the bus. The CQM1-ARM21 will use less than 100 mA from the AS-Interface line.

If the output current of a power supply unit is insufficient to power the whole configuration, use AS-Interface repeaters and power each segment separately.

### 2-3-2 AS-Interface Cable

The AS-Interface specification does not prescribe the use of the special AS-Interface 'yellow cable', as long as the cable meets the basic requirements as listed in 1-1-2, *System Components*.

The AS-Interface 'yellow cable' may be necessary to allow the installation of certain types of slave.





# 3 Specifications and Performance

This section describes the overall specifications and the communication performance of the CQM1-ARM21.

- 3-1 Overall Specifications ..... 18
- 3-2 Dimensions..... 19
- 3-3 Performance ..... 19
  - 3-3-1 AS-Interface Cycle Time ..... 20
  - 3-3-2 PLC Cycle Time ..... 20
  - 3-3-3 I/O Response Time ..... 21

### 3-1 Overall Specifications

<b>Model code</b>	CQM1-ARM21
<b>Max. number of units per CPU</b>	One
<b>Master Unit mounting position</b>	Recommended : rightmost I/O unit position of the CQM1 system
<b>Settings</b>	Switches: : IR channel allocation Operation Mode (Protected/Configuration) Store Configuration
<b>Displays</b>	Unit status : RUN (green LED) Startup, Normal operation ERR (red LED) Failure, illegal operation Network status : APF (red LED) AS-Interface Power Fail CER (red LED) Configuration Error AUP (yellow LED) Auto-programming available CM (yellow LED) Configuration Mode Slave status : 0~15, +16 (yellow LEDs) Slave configured / active
<b>External connectors</b>	2 x ASI+, 2 x ASI-, M3 screw terminals, detachable terminal block.
<b>No. of DM settings</b>	1 words of unit setup information (DM 6604)
<b>No. of IR words</b>	Switch selectable. Minimum: 3 words in + 3 words out      Maximum: 8 words in + 8 words out
<b>Max. No. of Slaves per Master Unit</b>	Switch selectable. With minimum IR words : 11 slaves      With maximum IR words : 31 slaves
<b>Status information in PLC</b>	Operation Mode flag System Error flag Normal Operation flag Configuration OK flag
<b>Communication specification</b>	European Standard EN 50295. AS-Interface Complete Specification V 2.04. AS-Interface Master Profiles V 1.5, profile M0. Prüfungsordnung für AS-Interface Master V 1.1. Certification No. 22701
<b>Network configuration</b>	Built-in configurator functions: <ul style="list-style-type: none"> <li>• Get_Permanent_Configuration</li> <li>• Set_Permanent_Configuration</li> <li>• Read_Actual_Configuration</li> <li>• Change_Slave_Address</li> <li>• Get_Permanent_Parameter</li> <li>• Set_Permanent_Parameter</li> <li>• Read_Parameter</li> <li>• Write_Parameter</li> </ul>
<b>Current consumption</b>	maximum 300 mA at 5 V DC (from the PLC power supply) maximum 100 mA at 30.5 V DC (from the AS-Interface line)
<b>Storage temperature</b>	-20 to +75°C
<b>Operating temperature</b>	0 to +55°C
<b>Operating humidity</b>	10% to 90% (non-condensing)
<b>Conformance to EMC- and environmental standards</b>	EN 50081-2 EN 61131-2
<b>Weight</b>	Approx. 200 g including front cover and terminal block

### 3-2 Dimensions

**Dimensions**

The following diagram shows the dimensions of the Master Unit. Refer to the CQM1 Operation Manual (W226-E1) for the dimensions of a complete PLC system.

All dimensions are in mm.

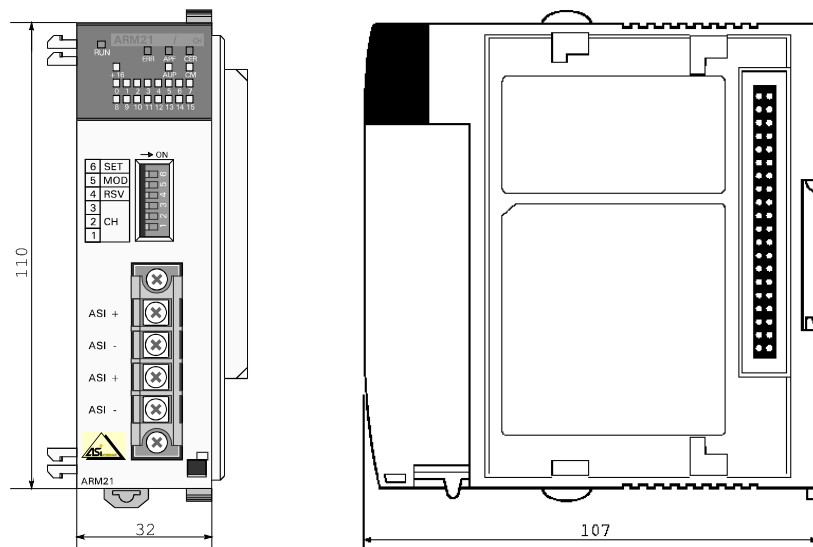

### 3-3 Performance

**Input response time**  
**Output response time**

The performance of the CQM1-ARM21 can be expressed in several ways. A common method is by definition of the input and output response times.

The input response time is the elapsed time between the moment that an input on a slave unit changes state, and the change of state of the corresponding data bit in the PLC memory.

The output response time is the opposite: the elapsed time between the change of state of a data bit in the PLC memory, and the moment that the corresponding output on a slave unit changes state.

Since AS-Interface is an open bus system, it is possible to use slave units from different vendors in one network. The internal delay times of I/O signals in these slave units should be considered in the performance measures.

**I/O response time**

Another performance measure of the complete system is the I/O response time. This is measured by transferring an input signal from a slave, via the PLC program, to the output of another (or even the same) slave. In this case the delay will also depend on the PLC cycle time.

**Asynchronous cycles**

Since in the CQM1-ARM21 the PLC cycle and the AS-Interface cycles are not synchronised, the response times are not constant values, but can be guaranteed to fall between a minimum and a maximum value.

### 3-3-1 AS-Interface Cycle Time

The maximum cycle time of an AS-Interface system is governed by the AS-Interface Complete Specification. If the number of slaves on the AS-Interface is less than the maximum of 31, the manufacturer is free to either fill the cycle with specific additional commands, or reduce the bus cycle time. The CQM1-ARM21 is designed to always provide the shortest possible bus cycle time.

In Normal Operation, without retransmission of messages due to disturbances, the bus cycle time of the CQM1-ARM21 depends on the number of detected slaves  $n$  as follows:

#### Formula

$$T_{AS-I} = 0.168 + n \times 0.154 \text{ ms}$$

With the maximum of 31 slaves this results in a cycle time of slightly under 5.0 ms.

The 0.168 ms is the time required in each bus cycle to execute the Inclusion Phase. In this phase the master searches for new slaves on the AS-Interface line. If no response is received, a time-out will cause the master to continue with the next data exchange phase 0.168 ms after the start of the inclusion phase.

The 0.154 ms is the time taken by each master request, slave response, and the pauses in between. The exact value of course depends on the delay with which each slave responds to a master request. The AS-Interface specification allows a margin of 3 bit times, or 18  $\mu$ s. All current slave implementations will give approximately the same response time.

While executing a command, e.g. to read or write the slave's parameters, the cycle time will be increased by an additional 0.154 ms.

#### Retransmissions

Electrical disturbances can cause the master to retransmit data exchange telegrams within an AS-Interface cycle. This can increase the AS-Interface cycle time up to double the normal cycle time.

### 3-3-2 PLC Cycle Time

The PLC's cycle time depends on:

- The PLC program to be executed.
- The number and types of I/O units in the system.
- Whether or not peripherals are connected to the CPU.

The CQM1-ARM21 will increase the PLC's cycle time by 0.01 ms times the number of allocated I/O words, i.e. a maximum of 0.16 ms.

See the *CQM1/CPM1 Programming manual (W228-E1)*, for details on the PLC cycle time.

### 3-3-3 I/O Response Time

The fieldbus cycle is not synchronised with the PLC cycle; fieldbus cycles are executed continuously, independent of the PLC cycle.

**Minimum I/O response time**

The figure below illustrates the minimum I/O response time. Shown are the timing at the PLC CPU, the AS-Interface bus, the Master Unit, the slave input and the slave output.

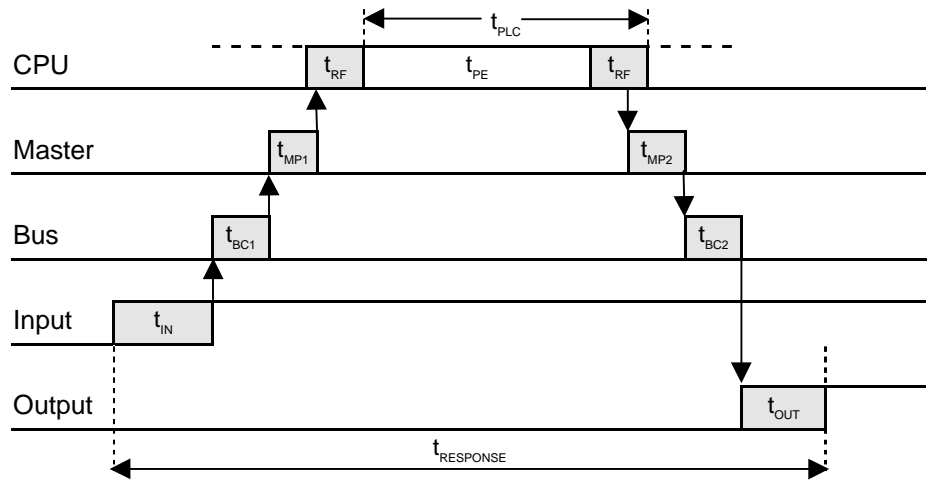

- $t_{IN}$  : Input Slave's ON (OFF) delay.  
Physical signal change at the terminals → data available for transmission.
- $t_{BC1}$  : Bus cycle delay. Minimal if the slave input data changed just before being serviced.
- $t_{MP1}$  : Master processing time.  
Start receiving slave response → data available at the I/O bus.
- $t_{RF}$  : I/O refresh time.  
Time required to update inputs and outputs of all CQM1 I/O units.
- $t_{PE}$  : Program Execution time  
Processing of the PLC program and peripherals
- $t_{PLC}$  : PLC Cycle time (scan time) =  $t_{PE} + t_{RF}$
- $t_{MP2}$  : Master processing time.  
Data available at the I/O bus interface → ODI updated.
- $t_{BC2}$  : Bus cycle delay. Minimal if the ODI was updated just before the master services the output slave.
- $t_{OUT}$  : Output Slave's ON (OFF) delay.  
Data received from master → physical signal change at the terminals.

$$t_{RESPONSE} = t_{IN} + 2 * (t_{BCx} + t_{MPx}) + t_{PLC} + t_{OUT}$$

in which  $t_{IN}$  and  $t_{OUT}$  are slave dependent, and  $t_{PLC}$  can be determined using a programming console or by monitoring AR27 in the CPU. The minimum value of  $(t_{BCx} + t_{MPx})$  is approximately the time required for one data exchange, i.e. 154  $\mu$ s.

**Maximum I/O response time** The figure below illustrates the maximum I/O response time. Shown are the timing at the PLC CPU, the timing at the Master Unit, the timing at the slave input and the timing at the slave output.

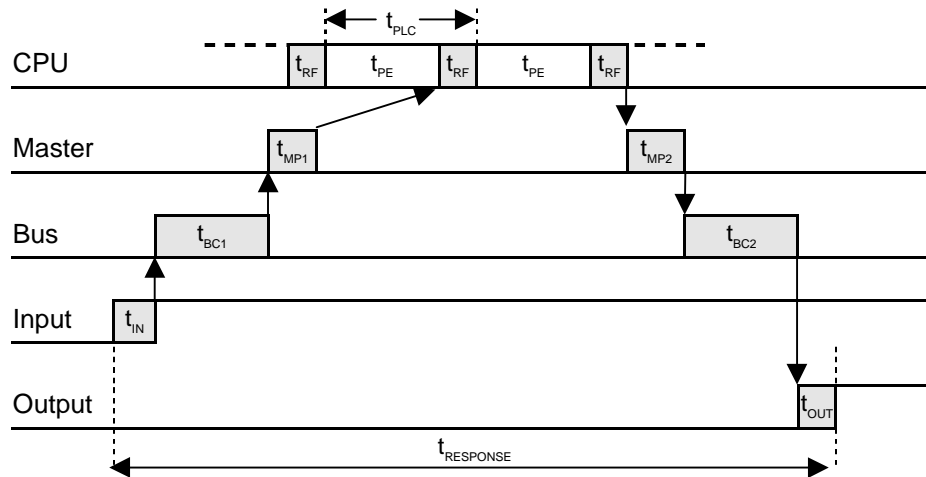

- $t_{IN}$  : Input Slave's ON (OFF) delay.  
Physical signal change at the terminals → data available for transmission.
- $t_{BC1}$  : Bus cycle time.  
If the slave's input data has changed just after a data exchange on the bus, it will take one AS-Interface bus cycle before the slave gets serviced again.
- $t_{MP1}$  : Master processing time.  
Start receiving slave response → data available at the I/O bus.
- $t_{RF}$  : I/O refresh time.  
Time required to update inputs and outputs of all CQM1 I/O units.
- $t_{PE}$  : Program Execution time  
Processing of the PLC program and peripherals
- $t_{PLC}$  : PLC Cycle time (scan time) =  $t_{PE} + t_{RF}$
- $t_{MP2}$  : Master processing time.  
Data available at the I/O bus interface → ODI updated.
- $t_{BC2}$  : Bus cycle time.  
If the ODI update took place just after the output slave has been serviced by the master, it will take one full AS-Interface bus cycle before the same slave gets serviced again.
- $t_{OUT}$  : Output Slave's ON (OFF) delay.  
Data received from master → physical signal change at the terminals.

$$t_{RESPONSE} = t_{IN} + (2 * t_{BCx}) + (2 * t_{MPx}) + (2 * t_{PLC}) + t_{OUT}$$

in which  $t_{IN}$  and  $t_{OUT}$  are slave dependent, and  $t_{PLC}$  can be determined using a programming console or by monitoring AR27 in the CPU.  
The maximum value of  $T_{MPx}$  is 2.0 ms.  
The value of  $T_{BCx}$  depends on the number of slaves, and under normal circumstances has a maximum of 5.0 ms at 31 slaves.

**Optimisation**

The processing time in the PLC can be reduced by using:

- the IORF instruction in the PLC program.
- Interrupt input refresh.
- Direct output refresh.

See the *CQM1/CPM1 Programming manual* (W228-E1) for details.





## 4 PLC Interface

This section describes the interface between the AS-Interface master and the CQM1 host PLC system.

4-1	PLC Settings.....	26
4-2	Internal Data Structures.....	27
4-3	Master Operation Modes.....	28
4-4	AS-Interface Standard Modes .....	31
	4-4-1 Status Flags .....	31
	4-4-2 Control Bits.....	32
	4-4-3 I/O Data Bits.....	33
4-5	Setup Mode .....	34
	4-5-1 Command Area .....	34
	4-5-2 Response Area.....	36
	4-5-3 Commands .....	37
	4-5-3-1 No Command .....	37
	4-5-3-2 Get_Permanent_Configuration.....	38
	4-5-3-3 Set_Permanent_Configuration .....	39
	4-5-3-4 Read_Actual_Configuration .....	40
	4-5-3-5 Change_Slave_Address.....	41
	4-5-3-6 Get_Permanent_Parameter.....	43
	4-5-3-7 Set_Permanent_Parameter .....	44
	4-5-3-8 Read_Parameter .....	45
	4-5-3-9 Write_Parameter .....	46
	4-5-4 Exit Setup Mode .....	47

## 4-1 PLC Settings

In principle, the CQM1-ARM21 requires no special preparation in the CQM1 PLC system. However, to allow an AS-Interface configuration larger than 23 slaves, the Unit will need to occupy 8 IR words as input area, plus 8 IR words as output area. With the 16 binary inputs already available in each CQM1 CPU, this would exceed the CPU's maximum of 16 I/O words (256 I/O points). The full extent of the ARM21's I/O capacity is currently only supported by the following CPU models:

- CQM1-CPU41-EV1-NL
- CQM1-CPU42-EV1-NL
- CQM1-CPU43-EV1-CE
- CQM1-CPU44-EV1-NL
- CQM1-CPU45-EV1-NL

Produced after 01-04-1999 at OMRON Manufacturing of the Netherlands.



With the above models, support for the CQM1-ARM21's I/O range can be activated by setting the following code in the CPU's PC Setup area:

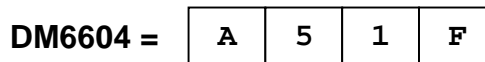

This code will allow the CQM1-ARM21 to access 2 additional IR words, above the CPU's normal limitation of 16. This means that apart from the built-in inputs of the CPU and a full-configuration AS-Interface master unit, one additional I/O unit can be mounted.

### Example

CQM1-CPU41 with OD215 (8-point out) and ARM21 (maximum allocation)

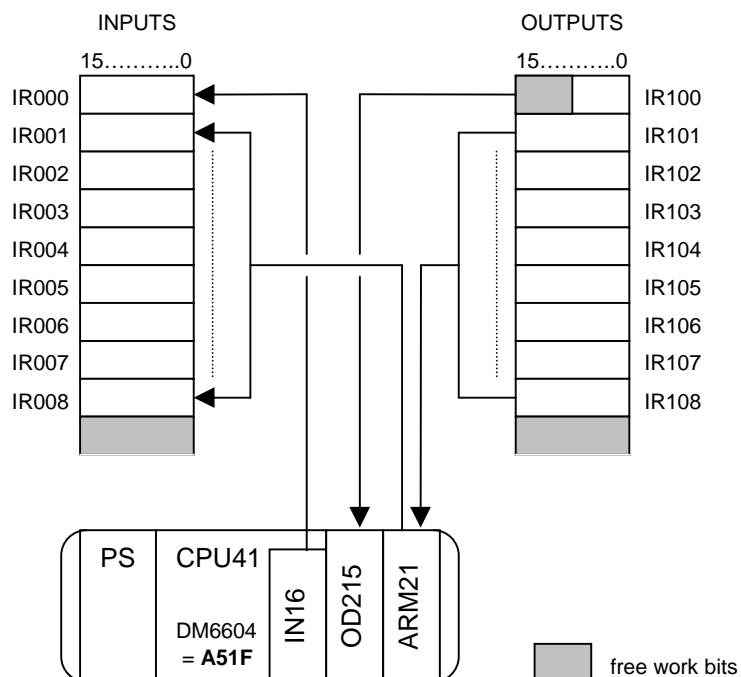

## 4-2 Internal Data Structures

An AS-Interface master uses several lists to keep track of the communication between the master and the slaves and to exchange data with the PLC CPU. Data that is used to describe the desired configuration of the AS-I system is stored in non-volatile memory.

The figure below shows an overview of the master's lists, and shows how data is transferred between the CQM1 CPU, these lists, and the slaves. For normal operation of the CQM1-ARM21, knowledge of its internal data structures is not essential, but it may help to better understand specific functions.

- Thin lines indicate that data of one particular slave is transferred.
- Thick lines indicate all data is transferred at once.

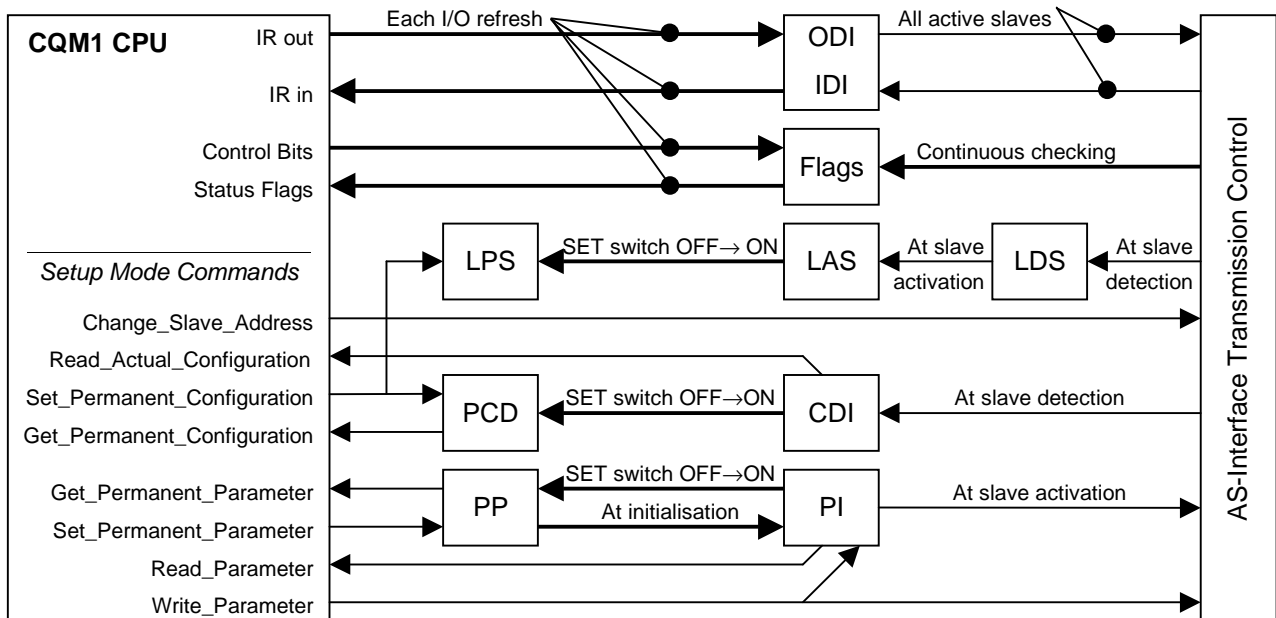

- ODI** Output Data Image.  
This array contains the data to be transmitted to the active slaves at the next data exchange.
- IDI** Input Data Image.  
This array contains the latest actual copies of the received data from the inputs of all active slaves. Input data of inactive slaves is set to zero (0).
- LDS** List of Detected Slaves.  
In this list one bit is set for each slave (0...31) that is detected by the master (through the start-up operation or inclusion phase).
- LAS** List of Activated Slaves.  
In this list one bit is set for each slave (1...31) that has been activated during start-up operation or inclusion phase.
- LPS** List of Projected Slaves.  
This list contains all slaves (1...31) expected in the AS-Interface system. The list is created either by local configuration of the master using Set\_Permanent\_Configuration commands, or copied

from the LDS with the SET switch. This data is stored in non-volatile memory.

- CDI** Configuration Data Image.  
This array contains copies of the actual input/output configuration and the identification code of all slaves (0 ...31), determined by reading this data from the slaves. The configuration data of inactive slaves is set to default values (FF<sub>H</sub>).
- PCD** Permanent Configuration Data.  
This array contains the projected input/output configuration and identification code of all slaves (1 ...31), created either by local configuration of the master using Set\_Permanent\_Configuration commands, or copied from the CDI with the SET switch. The permanent configuration data of slaves that are not projected is set to default values (FF<sub>H</sub>). This data is stored in non-volatile memory.
- PI** Parameter Image.  
This array contains the copies of the actual parameters of all active slaves (1...31). The PI data of inactive slaves is set to default values (F<sub>H</sub>).
- PP** Permanent Parameter.  
This array contains the configured parameters of all slaves (1...31), created either by local configuration of the master using Set\_Permanent\_Parameter commands, or copied from the PI with the SET switch. This data are stored in non-volatile memory. After master power on, the master copies the PP array to the PI array.

### 4-3 Master Operation Modes

The CQM1-ARM21 can be used in three different modes of operation.

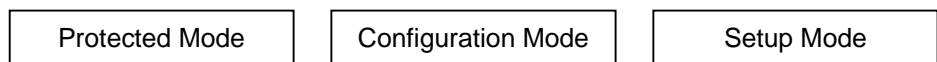

Selection of operation modes is done by:

1. the 'MOD' switch on the front of the unit (SW 5)
2. the 'Mode' Bit in the Command area (IR m.01)

Indication of the actual operation mode is by:

1. the CM LED on the front of the unit
2. the 'Mode' Flag in the Status area (IR n.00)

The mode and indications related to each combination can be found in the diagram below. If, for any reason, a selected mode cannot be activated, the ERR LED will be turned ON.

Mode Bit MOD switch	OFF (0)	ON (1)
OFF	<b>Configuration Mode</b> CM LED ON Mode Flag OFF	<b>Setup Mode</b> CM LED ON Mode Flag ON
ON	<b>Protected Mode</b> CM LED OFF Mode Flag OFF	<b>Protected Mode</b> CM LED OFF Mode Flag OFF

In some cases it may not be possible to change directly from one mode to another:

- Change from Configuration Mode to Protected Mode is not possible while a slave with address 0 is detected on the network.
- Change from Setup Mode to Protected Mode is not possible while the Mode Bit is ON.

In both cases, when setting the MOD switch from OFF to ON, the unit will remain in the previous mode (CM LED = ON), and the ERR LED will be ON. Set the MOD switch back OFF, then remove the slave 0 or set the Mode Bit OFF to allow a change to protected mode.

The AS-Interface 'Complete Specification' V2.04 defines two standard modes of operation: Configuration Mode and Protected Mode. In the additional Setup mode, the CQM1-ARM can be configured off-line, and can be used as a configuration tool for slaves.

### Protected Mode

Once installed and configured, the AS-Interface master will normally be set to Protected Mode. In this mode, only slaves that are in the list of projected slaves (LPS) and whose configuration data image (CDI) and permanent configuration data (PCD) are identical, will be activated.

The CDI and PCD of a slave are identical, if the input/output configuration and the identification code of the slave stored in the list of detected slaves (LDS) have the same values as those stored in the list of projected slaves (LPS) under the same slave address.

### Auto Addressing

If the Auto Addressing function of the AS-Interface master is enabled (default), it is possible to replace defective slaves by a 'blank' slave of the same type on-line. A blank slave means a slave with its address set to '0', and the same type means with identical ID code and identical I/O code. This process is called 'Auto-programming'

When the master detects one missing slave while in Protected Mode, the AUP LED will be set ON. The master will now scan the network for a slave with address 0, and if detected, read its ID code and I/O code. If these match the data of the missing slave in the master's permanent configuration, the master will change the slave address 0 to that of the missing slave automatically, and start exchanging I/O data. The AUP LED will go OFF.

If the user changes from Protected Mode to Configuration Mode while the AUP LED is ON, the Auto-programming process will be aborted. Upon return to Protected Mode, the Auto-programming process may be completed if there is still one single slave missing .

### Configuration Mode

In Configuration Mode, all detected slaves will be activated, even if they are not in the 'projected' configuration, or if their actual ID code or I/O code do not match the permanent configuration data. However, if there is a mismatch between actual and permanent configurations, this will still be indicated with the CER LED and by setting the Configuration\_OK Flag in the PLC to OFF.

While in Configuration Mode, it is possible to store all configuration data of the detected slaves in non-volatile memory as the 'projected' configuration (permanent configuration). This is done by changing the SET switch from OFF to ON position.

Auto-addressing can not be performed in Configuration Mode.

### Caution

The Configuration Mode can not be left as long as a slave with address 0 is detected. Setting the MOD switch to Protected Mode (=ON) will cause the ERR LED to turn on, while the unit stays in Configuration Mode (CM LED

remains ON). Set the MOD switch OFF again, remove slave 0, and set MOD back ON to enter Protected Mode.

A change from Configuration Mode to Protected Mode causes a restart of the AS-Interface master, starting with the off-line phase. As a result, all slaves will temporarily be reset.

**Setup Mode**

Setup mode is not defined by the AS-Interface Specification. In Setup Mode the CQM1-ARM21 does not comply with the requirements of an AS-Interface master in the sense that I/O data exchange with the Host PLC system is partially suspended. Instead, the user can issue commands via the PLC to be processed by the master, in order to build up the configuration from scratch without additional configuration tools.

## 4-4 AS-Interface Standard Modes

Protected Mode and Configuration Mode are the modes of operation in which the CQM1-ARM21 acts as an 'M0' AS-Interface Master, and cyclically exchanges I/O data between the host PLC and the slaves. The other mode of operation is Setup mode, in which the Unit acts as a configuration tool, allowing the user to modify the AS-Interface configuration.

In these standard modes, the I/O words assigned to the CQM1-ARM21 will represent the I/O data of the connected AS-Interface slaves. The number of allocated I/O words depends on the setting of the CH switches 1-3 (see 2-1-3 Switches).

Apart from the I/O data, the first input word contains 4 bits indicating the status of the AS-I master, and the first output word contains 2 bits to control the AS-Interface master.

The first input word allocated to the Unit is indicated as IR n (n = 001~006).

The first output word allocated to the Unit is indicated as IR m (m = 100~106).

The Status Flags are inputs to the PLC Host system that indicate the state of the AS-Interface system. The Command bits are outputs from the PLC Host system to the AS-Interface master to control its operation mode.

### 4-4-1 Status Flags

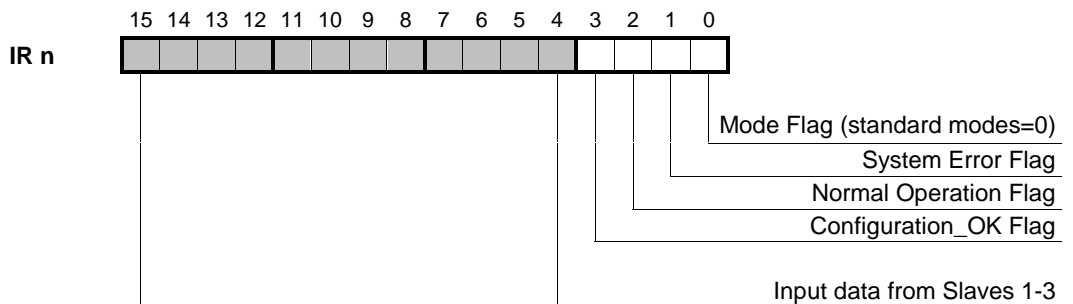

#### IR n.00 Mode Flag

- 0 Standard Operation Modes.  
The AS-Interface Master is in Configuration Mode or in Protected Mode. I/O data exchange between PLC and slaves is active.
- 1 Setup Mode (see 4-5, *Setup Mode*)  
I/O data exchange between PLC and the master is partially suspended (inputs of slaves 1~3, outputs of slaves 1~7). Data exchange between master and slaves continues.

#### IR n.01 System Error Flag

- 0 No errors.
- 1 An error was detected, being either:
  - Low Power on the AS-Interface line.
  - Hardware failure of the Master Unit.

- IR n.02 Normal\_Operation Flag**
- 0 Master is not in Normal Operation.  
The AS-Interface master is not executing cyclic data exchanges with its slaves.
  - 1 Master is in Normal Operation.  
The master executes the AS-Interface cycle of Data Exchange, Management and Inclusion Phases.
- See also 1-1-3, *Technical Details*.
- IR n.03 Configuration\_OK Flag**
- 0 Configuration Error.  
At least one mismatch exists between the permanent configuration data and the slaves actually detected on the network.
  - 1 Configuration is OK.  
The actual configuration matches the configuration data stored in non-volatile memory, i.e. all detected slaves have an ID code and I/O code as in the permanent configuration data.

### 4-4-2 Control Bits

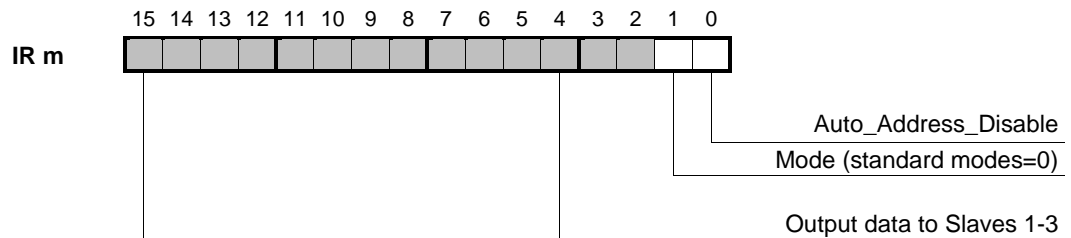

- IR m.00 Auto\_Address\_Disable Bit**
- 0 Auto Addressing is enabled.  
When the AS-Interface master is in Protected Mode, it is possible to replace slaves on-line by 'blank' slaves (address 0) with the same ID- and I/O codes.
  - 1 Auto Addressing is disabled.
- IR m.01 Mode Control Bit**
- 0 Standard Modes  
Requests the master to operate in Configuration / Protected Mode, depending on the position of the MOD switch.
  - 1 Setup Mode  
Requests the master to operate in Setup Mode. This request will only be granted when the MOD switch is OFF.
- After setting this bit, always check IR n.00 (Mode Flag) to determine the actual operating state of the master. If the master is set to Protected Mode by the MOD switch, setting the Mode Control Bit to Setup Mode will have no effect.



### 4-4-3 I/O Data Bits

After the master has completed the initialisation, and has entered Normal Operation, it will cyclically update each slave's I/O data in the Input Data Image and the Output Data Image.

The PLC CPU will access the master's IDI and ODI during the PLC's I/O refresh, which takes place every PLC scan. The data in the IDI and ODI is mapped to the I/O areas assigned to the CQM1-ARM21 as shown below.

Even if a slave has only outputs, its input data area will still be updated each PLC cycle. The input data is copied straight from the slave reply. Check the specifications of each slave to find out if any relevant information is returned.

The same is true for input-only slaves. Although in most cases the data sent to input slaves will be irrelevant, slaves may interpret the data bits sent to it to perform specific functions.

#### Inputs

	15	14	13	12	11	10	9	8	7	6	5	4	3	2	1	0	IR bits
IR n	Slave 3		Slave 2		Slave 1		Status Bits										Inputs from slaves 1-3
IR n+1	Slave 7		Slave 6		Slave 5		Slave 4										Inputs from slaves 4-7
IR n+2	Slave 11		Slave 10		Slave 9		Slave 8										Inputs from slaves 8-11
IR n+3	Slave 15		Slave 14		Slave 13		Slave 12										Inputs from slaves 12-15
IR n+4	Slave 19		Slave 18		Slave 17		Slave 16										Inputs from slaves 16-19
IR n+5	Slave 23		Slave 22		Slave 21		Slave 20										Inputs from slaves 20-23
IR n+6	Slave 27		Slave 26		Slave 25		Slave 24										Inputs from slaves 24-27
IR n+7	Slave 31		Slave 30		Slave 29		Slave 28										Inputs from slaves 31-28
	D3	D2	D1	D0	D3	D2	D1	D0	D3	D2	D1	D0	D3	D2	D1	D0	Data bits from slaves

#### Outputs

	15	14	13	12	11	10	9	8	7	6	5	4	3	2	1	0	IR bits
IR m	Slave 3		Slave 2		Slave 1		Command Bits										Outputs to slaves 1-3
IR m+1	Slave 7		Slave 6		Slave 5		Slave 4										Outputs to slaves 4-7
IR m+2	Slave 11		Slave 10		Slave 9		Slave 8										Outputs to slaves 8-11
IR m+3	Slave 15		Slave 14		Slave 13		Slave 12										Outputs to slaves 12-15
IR m+4	Slave 19		Slave 18		Slave 17		Slave 16										Outputs to slaves 16-19
IR m+5	Slave 23		Slave 22		Slave 21		Slave 20										Outputs to slaves 20-23
IR m+6	Slave 27		Slave 26		Slave 25		Slave 24										Outputs to slaves 24-27
IR m+7	Slave 31		Slave 30		Slave 29		Slave 28										Outputs to slaves 31-28
	D3	D2	D1	D0	D3	D2	D1	D0	D3	D2	D1	D0	D3	D2	D1	D0	Data bits to slaves

If the I/O range is restricted by the setting of the front panel DIP switches 1-3, unused IR words can be allocated to other I/O units or used as work bits.

Note: The PLC scan cycle and the AS-Interface cycle are independent and unsynchronised. Output data transferred to the CQM1-ARM21 in one PLC scan can arrive at subsequent slave addresses with a delay of up to 5 ms (i.e. the maximum AS-Interface cycle time). This depends on which slave has just been serviced in the AS-Interface cycle. Data consistency is only guaranteed within one slave's data 'nibble'.

## 4-5 Setup Mode

In Setup Mode, as opposed to the standard Configuration / Protected Modes, the AS-Interface master will:

- continue to exchange I/O data with all detected slaves.
- stop transferring output data for slaves 1~7 and input data from slaves 1~3 between the AS-Interface master and the host PLC.
- allow the user to send configuration commands from the PLC to the AS-Interface master.

This effectively means that the output data that the master sends to slaves 1~7 is static, and equal to the last data received from the PLC before changing to Setup Mode. Input data from slaves 1~3 is still collected by the master, and stored internally, to be transferred to the PLC when leaving Setup Mode.

**⚠ Caution**

It is recommended to use Setup mode only during installation, commissioning and maintenance activities, while the controlled machinery is not in operation. Setup Mode allows the user to configure an AS-Interface system without the necessity of additional configuration tools. Functions accessible to the user only in Setup Mode are:

- Reading and writing of the 'permanent' configuration data in the master. Each projected slave's ID Code and I/O Configuration are stored in non-volatile memory in the master. This permanent data defines the projected slave configuration, which the master will use to check against for errors in the actual, detected configuration. Additionally, each slave's projected parameter values can be read and written.
- Reading of configuration and parameter data, and writing of address and parameters of any slave actually connected to the AS-Interface network.

Setup Mode can only be entered if the CQM1-ARM21 is set to Configuration Mode with the MOD switch (switch 5).

### 4-5-1 Command Area

In Setup Mode, the first two output words allocated in the CPU are used to transfer a specific command to the master unit.

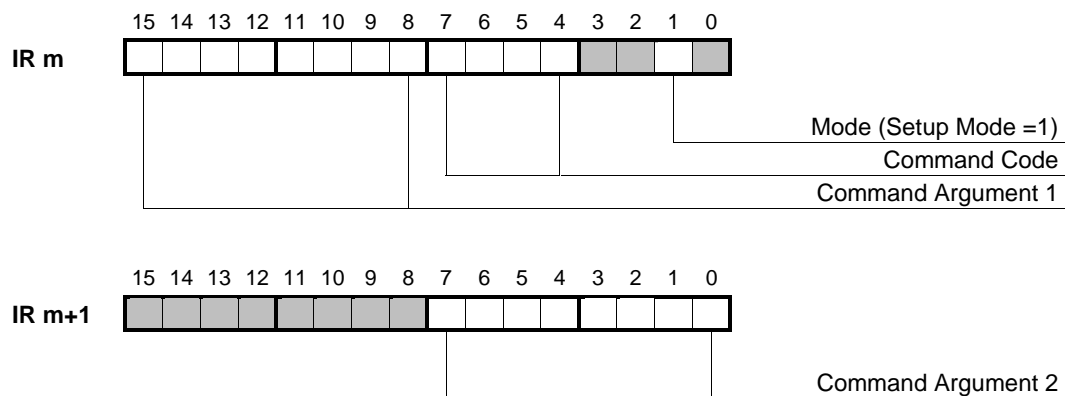

**IR m.01 Mode Control Bit**

- 0 Standard Modes  
Requests the master to operate in Configuration / Protected Mode, depending on the position of the MOD switch.
- 1 Setup Mode  
To enter Setup Mode, set this bit to 1, i.e. set the least significant digit of IR m to 2.  
If the MOD switch (DIP switch 5) is OFF, the Unit will enter Setup Mode. If the MOD switch is ON, the Unit will remain in Protected Mode.  
Check the Mode Flag in the Response area to see if the master actually is in Setup Mode, before issuing commands. As long as the Mode Flag is not set ON, the Command Code and Command Arguments will be interpreted as output data for slaves 1 to 5.

**IR m.04~ Command Code**

**IR m.07** In Setup mode, the following single-digit command codes are valid:

- 0 No Command**  
Setting the Command Code to 0 prepares the master for the next command. Command Code 0 MUST be issued before each command.
- 1 Get\_Permanent\_Configuration**  
Returns the master's permanent configuration data for one slave address.
- 3 Set\_Permanent\_Configuration**  
Sets the master's permanent configuration data for one slave address.
- 5 Read\_Actual\_Configuration**  
Returns the configuration data from an actual slave connected to the AS-Interface network.
- 7 Change\_Slave\_Address**  
Changes the address of an actual slave connected to the AS-Interface network.
- 9 Get\_Permanent\_Parameter**  
Returns the master's permanent parameter data for one slave address.
- B Set\_Permanent\_Parameter**  
Sets the master's permanent parameter data for one slave address.
- D Read\_Parameter**  
Returns the parameter data from an actual slave connected to the AS-Interface network.
- F Write\_Parameter**  
Changes the parameter data of an actual slave connected to the AS-Interface network.

The master will ignore any Command Code not included above.

**IR m.08~ Command Argument 1**

**IR m.15** A 2-digit BCD code representing the target slave address for the command.

For details, see the descriptions of the individual commands.

**IR m+1.00~ Command Argument 2**

**IR m+1.07** Depending on the type of command to be issued, a 2-digit hexadecimal code, a BCD code or binary data may need to be provided.

For details, see the descriptions of the individual commands.

### 4-5-2 Response Area

In Setup Mode, the first input word allocated in the CPU will contain the master's response to a command, in addition to the status flags.

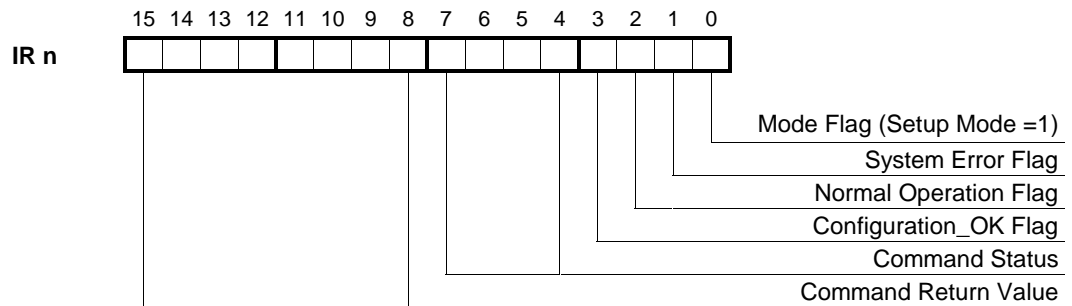

**IR n.00~ Status Flags**

**IR n.03** See 4-4-1, Status Flags

**IR n.04~ Command Status**

- IR n.07**
- 0 No command was issued through IR m~m+1.
  - 1 The command issued through IR m~m+1 was executed correctly.
  - 2 The command issued through IR m~m+1 was incorrect or could not be executed.

**IR n.08~ Command Return Value**

**IR n.15** Command Return values will be explained in detail at the description of each specific command below.

### 4-5-3 Commands

In Setup Mode, the user can issue a range of commands as defined in the AS-Interface Specification, that provide the possibility to completely configure an AS-Interface network without the use of additional programming or addressing tools.

The method to issue a command is always the same:

1. The 'No Command' code is set prepare the master for a new command code. The 'No Command' code requires no command arguments.
2. The user checks that the Command Status is cleared (= 0)
3. The user enters a command code, and the arguments for that command, making sure that the arguments are available to the master at the moment that the command code is set.
4. The user checks the Command Status, and if applicable, the Command Return Value.

This sequence can be repeated as required, or it can be interrupted in any stage by changing to Configuration Mode (Mode Control Bit).



**Caution**

The user is to make sure that the Mode Flag is ON before a command is sent. If the Mode Flag is OFF, e.g. due to the MOD switch forcing the unit to stay in Protected Mode (switch=ON), the master will interpret the command and argument data as output data for slaves 1 through 5.

#### 4-5-3-1 No Command

**Function**

Prepare the master for the reception of a new command from the PLC. Must be set after entering into Setup Mode, and before each new command.

<b>Command Code</b>	0 (0000)
<b>Command Argument 1</b>	Not required.
<b>Command Argument 2</b>	Not required.
<b>Command Status</b>	0 Ready for new command. Other Master is busy.
<b>Command Return Value</b>	Not applicable (set to 00).

**Example**

Enter Setup Mode and prepare for first command

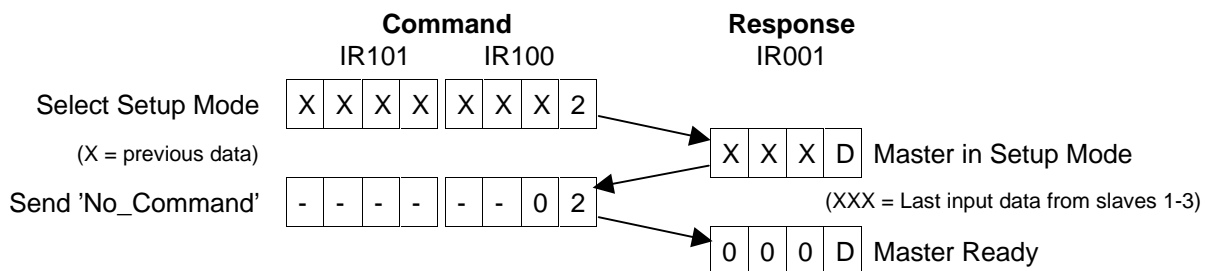

Note: It is also possible to select Setup Mode AND send 'No\_Command' in the same PLC scan by changing IR100 from XXX0 to XX02. The above method is safer if the output data of slave 1 needs to be held during execution of Setup Commands.

4-5-3-2 Get\_Permanent\_Configuration

**Function** Read the ID code and I/O code of a slave from the permanent configuration data in the master's non-volatile memory.

<b>Command Code</b>	1 (0001)																																	
<b>Command Argument 1</b>	Slave address (2 digits BCD).																																	
<b>Command Argument 2</b>	Not required.																																	
<b>Command Status</b>	1 Command processed, and Return Value is valid. 2 Error in processing the command (invalid argument value or EEPROM read error). other Master is busy.																																	
<b>Command Return Value</b>	Permanent Configuration Data for slave [Command Argument 1]. 1 byte hexadecimal code, representing I/O Code and ID Code. <div style="text-align: center;"> <table border="1" style="margin-left: auto; margin-right: auto;"> <tr> <td></td><td>15</td><td>14</td><td>13</td><td>12</td><td>11</td><td>10</td><td>9</td><td>8</td><td>7</td><td>6</td><td>5</td><td>4</td><td>3</td><td>2</td><td>1</td><td>0</td> </tr> <tr> <td>IR n</td> <td colspan="2">I/O</td> <td colspan="4">ID</td> <td>0</td><td>0</td><td>0</td><td>1</td> <td colspan="2" style="background-color: #cccccc;"></td> <td colspan="2" style="background-color: #cccccc;"></td> <td>1</td> </tr> </table> </div> <div style="text-align: right; margin-top: 10px;"> <span style="font-size: small;">Setup Mode</span>  <span style="font-size: small;">Command Status = OK</span>  <span style="font-size: small;">ID Code</span>  <span style="font-size: small;">I/O Code</span> </div> See Appendix B, <i>AS-Interface Slave Profiles</i> , for a list of ID codes and I/O codes.		15	14	13	12	11	10	9	8	7	6	5	4	3	2	1	0	IR n	I/O		ID				0	0	0	1					1
	15	14	13	12	11	10	9	8	7	6	5	4	3	2	1	0																		
IR n	I/O		ID				0	0	0	1					1																			

**Example** Read projected configuration data of the slave with address 18.

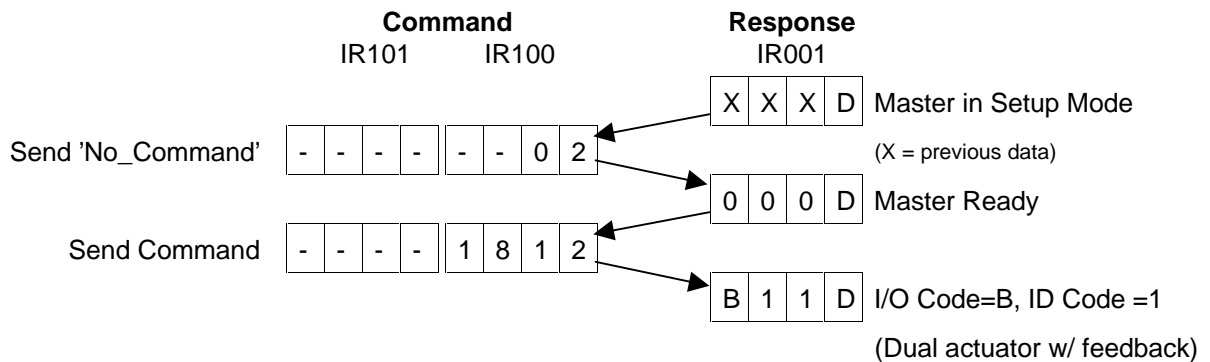

4-5-3-3 Set\_Permanent\_Configuration

**Function** Store the ID code and I/O code for a projected slave as permanent configuration data in the master's non-volatile memory.

<b>Command Code</b>	3 (0011)																																																																
<b>Command Argument 1</b>	Slave address (2 digits BCD)																																																																
<b>Command Argument 2</b>	<p>Permanent Configuration Data for slave [Command Argument 1].                      1 byte hexadecimal code, representing I/O Code and ID Code.</p> <p style="text-align: center;">15 14 13 12 11 10 9 8 7 6 5 4 3 2 1 0</p> <p>IR m+1 <table style="display: inline-table; border-collapse: collapse;"> <tr> <td style="border: 1px solid black; width: 15px; height: 15px;"></td> <td style="border: 1px solid black; width: 15px; height: 15px;"></td> <td style="border: 1px solid black; width: 15px; height: 15px;"></td> <td style="border: 1px solid black; width: 15px; height: 15px;"></td> <td style="border: 1px solid black; width: 15px; height: 15px;"></td> <td style="border: 1px solid black; width: 15px; height: 15px;"></td> <td style="border: 1px solid black; width: 15px; height: 15px;"></td> <td style="border: 1px solid black; width: 15px; height: 15px;"></td> <td style="border: 1px solid black; width: 15px; height: 15px;"></td> <td style="border: 1px solid black; width: 15px; height: 15px;"></td> <td style="border: 1px solid black; width: 15px; height: 15px;"></td> <td style="border: 1px solid black; width: 15px; height: 15px;"></td> <td style="border: 1px solid black; width: 15px; height: 15px;"></td> <td style="border: 1px solid black; width: 15px; height: 15px;"></td> <td style="border: 1px solid black; width: 15px; height: 15px;"></td> <td style="border: 1px solid black; width: 15px; height: 15px;"></td> </tr> <tr> <td colspan="11"></td> <td colspan="2" style="text-align: center; border: none;">I/O</td> <td colspan="2" style="text-align: center; border: none;">ID</td> <td style="border: none;"></td> </tr> <tr> <td colspan="11"></td> <td colspan="2" style="border: none;"></td> <td colspan="2" style="border: none;"></td> <td style="border: none; text-align: right;">ID Code</td> </tr> <tr> <td colspan="11"></td> <td colspan="2" style="border: none;"></td> <td colspan="2" style="border: none;"></td> <td style="border: none; text-align: right;">I/O Code</td> </tr> </table> <p>See Appendix B, <i>AS-Interface Slave Profiles</i>, for a list of ID codes and I/O codes.</p> </p>																												I/O		ID																		ID Code																I/O Code
											I/O		ID																																																				
															ID Code																																																		
															I/O Code																																																		
<b>Command Status</b>	1 Command processed. 2 Error in processing the command (invalid argument value or EEPROM write error). other Master is busy																																																																
<b>Command Return Value</b>	Not applicable (set to 00)																																																																

**Example** Define the projected configuration data for the slave with address 23 as a standard 2-input, 2-output slave. (I/O Code 3, ID Code 0)

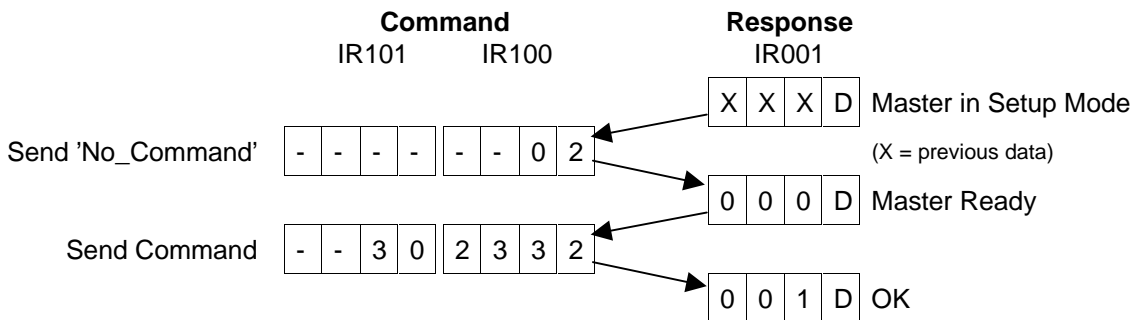

4-5-3-4 Read\_Actual\_Configuration

**Function** Read the ID code and I/O code of an actual slave connected to the AS-Interface line.

<b>Command Code</b>	5 (0101)																																
<b>Command Argument 1</b>	Slave address (2 digits BCD).																																
<b>Command Argument 2</b>	Not required.																																
<b>Command Status</b>	1 Command processed, and Return Value is valid. 2 Error in processing the command (invalid argument value or Slave read error). other Master is busy.																																
<b>Command Return Value</b>	Actual Configuration Data for slave [Command Argument 1]. 1 byte hexadecimal code, representing I/O Code and ID Code. 15 14 13 12 11 10 9 8 7 6 5 4 3 2 1 0 IR n <table border="1" style="display: inline-table; vertical-align: middle;"> <tr> <td style="width: 15px; height: 15px;"></td><td style="width: 15px; height: 15px;"></td><td style="width: 15px; height: 15px;"></td><td style="width: 15px; height: 15px;"></td><td style="width: 15px; height: 15px;"></td><td style="width: 15px; height: 15px;"></td><td style="width: 15px; height: 15px;"></td><td style="width: 15px; height: 15px;"></td><td style="width: 15px; height: 15px;"></td><td style="width: 15px; height: 15px;"></td><td style="width: 15px; height: 15px;"></td><td style="width: 15px; height: 15px;"></td><td style="width: 15px; height: 15px;"></td><td style="width: 15px; height: 15px;"></td><td style="width: 15px; height: 15px;"></td><td style="width: 15px; height: 15px;"></td> </tr> <tr> <td></td><td></td><td></td><td></td><td></td><td></td><td></td><td>0</td><td>0</td><td>0</td><td>1</td><td style="background-color: #cccccc;"></td><td style="background-color: #cccccc;"></td><td style="background-color: #cccccc;"></td><td style="background-color: #cccccc;"></td><td>1</td> </tr> </table> <div style="display: flex; justify-content: space-between; align-items: flex-end; margin-top: 10px;"> <div style="border: 1px solid black; width: 100px; height: 100px; margin-left: 100px;"></div> <div style="text-align: right; margin-right: 20px;">                     Setup Mode                      Command Status = OK                      I/O Code                      ID Code                 </div> </div> See Appendix B, <i>AS-Interface Slave Profiles</i> , for a list of ID codes and I/O codes.																								0	0	0	1					1
							0	0	0	1					1																		

**Example** Try to read the configuration data of the (non-existing) slave with address 18.

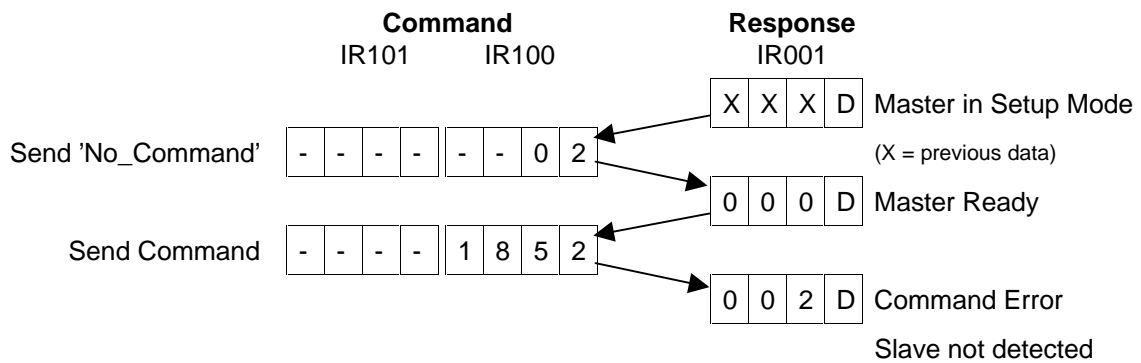



4-5-3-5 Change\_Slave\_Address

**Function** Change the address of an actual slave connected to the AS-Interface line, and store the new address in the slave's EEPROM.  
 To change a slave's address, the master first temporarily sets the target's address to 0, then writes the new address. Therefore, this command cannot be performed if a slave 0 exists on the network.

<b>Command Code</b>	7 (0111)																																
<b>Command Argument 1</b>	Old slave address (2 digits BCD).																																
<b>Command Argument 2</b>	New slave address (2 digits BCD).																																
<b>Command Status</b>	1 Command processed successfully. 2 Error in processing the command, check Return Value. other Master is busy.																																
<b>Command Return Value</b>	<p>Result of the Change_Slave_Address Command (error flags).                      If all error flags are off, and Command Status =1, the command was processed successfully. If not, the following flags indicate the type of error:</p> <div style="text-align: center;"> <table border="1" style="margin-left: auto; margin-right: auto;"> <tr> <td style="padding: 2px;">15</td><td style="padding: 2px;">14</td><td style="padding: 2px;">13</td><td style="padding: 2px;">12</td><td style="padding: 2px;">11</td><td style="padding: 2px;">10</td><td style="padding: 2px;">9</td><td style="padding: 2px;">8</td><td style="padding: 2px;">7</td><td style="padding: 2px;">6</td><td style="padding: 2px;">5</td><td style="padding: 2px;">4</td><td style="padding: 2px;">3</td><td style="padding: 2px;">2</td><td style="padding: 2px;">1</td><td style="padding: 2px;">0</td> </tr> <tr> <td style="padding: 2px;">IR n</td><td style="padding: 2px;"></td><td style="padding: 2px;"></td><td style="padding: 2px;"></td><td style="padding: 2px;"></td><td style="padding: 2px;"></td><td style="padding: 2px;"></td><td style="padding: 2px;"></td><td style="padding: 2px;">0</td><td style="padding: 2px;">0</td><td style="padding: 2px;">1</td><td style="padding: 2px;">0</td><td style="padding: 2px;"></td><td style="padding: 2px;"></td><td style="padding: 2px;"></td><td style="padding: 2px;">1</td> </tr> </table> </div> <p>SND The slave specified by Command Argument 1 was not detected on the network.                  SD0 A slave with address 0 was already detected, address change cannot be made, since address 0 is to be assigned temporarily.                  SD2 A slave with the target address specified by Command Argument 2 already exists on the network.                  DE The slave did not accept the deletion of the old address.                  SE The slave did not accept the new address.                  AT The slave accepted the new address, but it was not stored in non-volatile memory. If the slave gets reset, it will assume the old address.</p>	15	14	13	12	11	10	9	8	7	6	5	4	3	2	1	0	IR n								0	0	1	0				1
15	14	13	12	11	10	9	8	7	6	5	4	3	2	1	0																		
IR n								0	0	1	0				1																		

**Example 1** Change the address of slave 23 to 31.

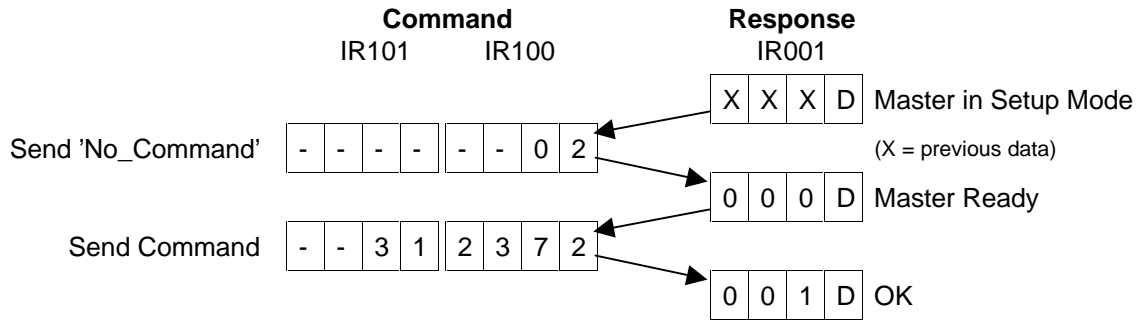

**Example 2** Change the address of slave 1 to 31, while slave 31 already exists on the network.

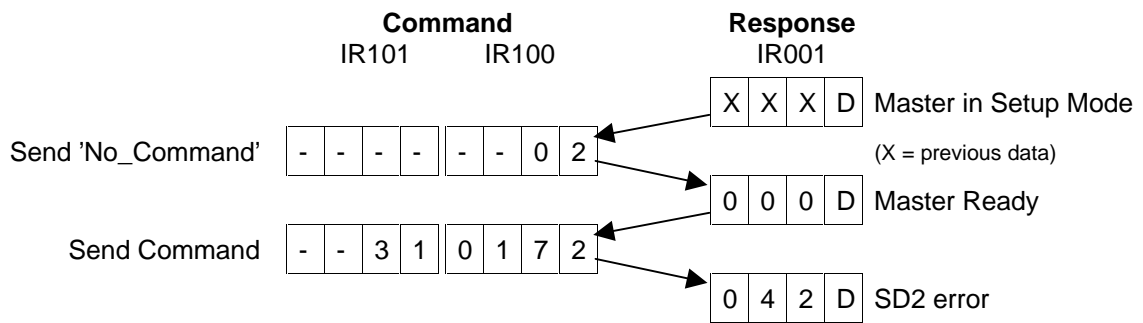

4-5-3-6 Get\_Permanent\_Parameter

Function Read the Parameter Bits of a slave from the permanent configuration data in the master's non-volatile memory.

<b>Command Code</b>	9 (1001)																																
<b>Command Argument 1</b>	Slave address (2 digits BCD).																																
<b>Command Argument 2</b>	Not required.																																
<b>Command Status</b>	1 Command processed, and Return Value is valid. 2 Error in processing the command (invalid argument value or EEPROM read error). other Master is busy.																																
<b>Command Return Value</b>	Permanent Parameter Data of slave [Command Argument 1]. 4 bits as below: <div style="text-align: center;"> <table border="1" style="margin-left: auto; margin-right: auto;"> <tr> <td>15</td><td>14</td><td>13</td><td>12</td><td>11</td><td>10</td><td>9</td><td>8</td><td>7</td><td>6</td><td>5</td><td>4</td><td>3</td><td>2</td><td>1</td><td>0</td> </tr> <tr> <td>IR n</td><td></td><td></td><td></td><td></td><td>P3</td><td>P2</td><td>P1</td><td>P0</td><td>0</td><td>0</td><td>0</td><td>1</td><td></td><td></td><td>1</td> </tr> </table>   <div style="display: flex; justify-content: center; align-items: center; gap: 20px;"> <div style="border: 1px solid black; width: 40px; height: 40px; margin-left: 20px;"></div> <div style="border: 1px solid black; width: 40px; height: 40px; margin-left: 20px;"></div> <div style="border: 1px solid black; width: 40px; height: 40px; margin-left: 20px;"></div> <div style="border: 1px solid black; width: 40px; height: 40px; margin-left: 20px;"></div> <div style="border: 1px solid black; width: 40px; height: 40px; margin-left: 20px;"></div> <div style="border: 1px solid black; width: 40px; height: 40px; margin-left: 20px;"></div> <div style="border: 1px solid black; width: 40px; height: 40px; margin-left: 20px;"></div> <div style="border: 1px solid black; width: 40px; height: 40px; margin-left: 20px;"></div> </div> <div style="text-align: right; margin-top: 5px;">       Setup Mode        Command Status = OK        Parameter Data     </div> </div> The meaning of Parameters P0~P4 is slave specific.	15	14	13	12	11	10	9	8	7	6	5	4	3	2	1	0	IR n					P3	P2	P1	P0	0	0	0	1			1
15	14	13	12	11	10	9	8	7	6	5	4	3	2	1	0																		
IR n					P3	P2	P1	P0	0	0	0	1			1																		

Example Read the projected parameter data of the slave with address 4.

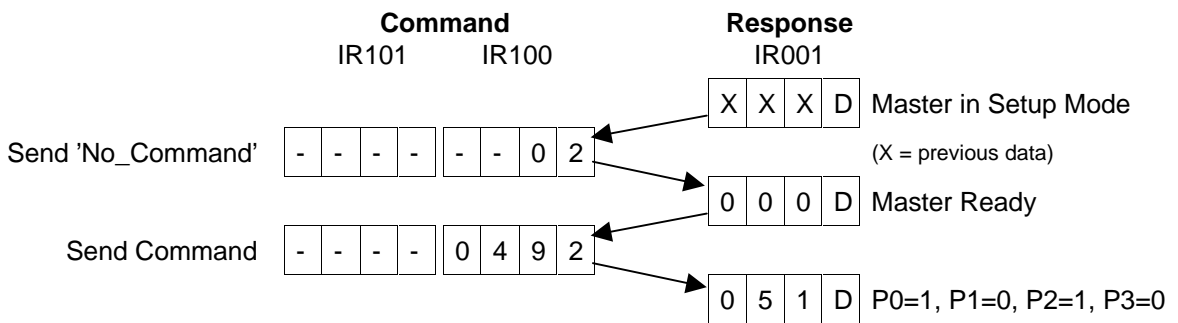

4-5-3-7 Set\_Permanent\_Parameter

**Function** Store the Parameter Bits for a slave as permanent configuration data in the master's non-volatile memory.

<b>Command Code</b>	B (1011)																																		
<b>Command Argument 1</b>	Slave address (2 digits BCD).																																		
<b>Command Argument 2</b>	Permanent Parameter Data for slave [Command Argument 1]. 4 bits as below: <div style="text-align: center;"> <table style="margin: auto;"> <tr> <td></td><td>15</td><td>14</td><td>13</td><td>12</td><td>11</td><td>10</td><td>9</td><td>8</td><td>7</td><td>6</td><td>5</td><td>4</td><td>3</td><td>2</td><td>1</td><td>0</td> </tr> <tr> <td>IR m+1</td> <td style="border: 1px solid black;"></td><td style="border: 1px solid black;"></td><td style="border: 1px solid black;"></td><td style="border: 1px solid black;"></td><td style="border: 1px solid black;"></td><td style="border: 1px solid black;"></td><td style="border: 1px solid black;"></td><td style="border: 1px solid black;"></td><td style="border: 1px solid black;"></td><td style="border: 1px solid black;"></td><td style="border: 1px solid black;"></td><td style="border: 1px solid black;"></td><td style="border: 1px solid black;">P3</td><td style="border: 1px solid black;">P2</td><td style="border: 1px solid black;">P1</td><td style="border: 1px solid black;">P0</td> </tr> </table> </div> <div style="text-align: right; margin-right: 20px;">Parameter Data</div> The meaning of Parameters P0~P4 is slave specific.		15	14	13	12	11	10	9	8	7	6	5	4	3	2	1	0	IR m+1													P3	P2	P1	P0
	15	14	13	12	11	10	9	8	7	6	5	4	3	2	1	0																			
IR m+1													P3	P2	P1	P0																			
<b>Command Status</b>	1 Command processed successfully. 2 Error in processing the command (invalid argument value or EEPROM write error). other Master is busy.																																		
<b>Command Return Value</b>	Not applicable.																																		

**Example** Define the projected parameter data for the slave with address 25 as P0=0, P1=1, P2=1, P3=0

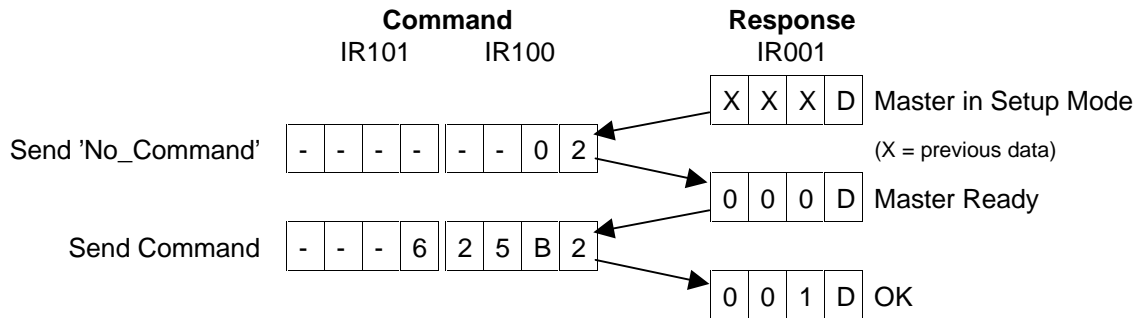

4-5-3-8 Read\_Parameter

**Function** Read the Parameter Bits of an actual slave connected to the AS-Interface network.

<b>Command Code</b>	D (1101)																																																			
<b>Command Argument 1</b>	Slave address (2 digits BCD).																																																			
<b>Command Argument 2</b>	Not required.																																																			
<b>Command Status</b>	<p>1 Command processed, and Return Value is valid.</p> <p>2 Error in processing the command (invalid argument value or Slave read error).</p> <p>other Master is busy.</p>																																																			
<b>Command Return Value</b>	<p>Permanent Parameter Data of slave [Command Argument 1].</p> <p>4 bits as below:</p> <div style="text-align: center;"> <table style="margin: auto;"> <tr> <td></td><td>15</td><td>14</td><td>13</td><td>12</td><td>11</td><td>10</td><td>9</td><td>8</td><td>7</td><td>6</td><td>5</td><td>4</td><td>3</td><td>2</td><td>1</td><td>0</td> </tr> <tr> <td>IR n</td> <td style="background-color: #cccccc;"></td><td style="background-color: #cccccc;"></td><td style="background-color: #cccccc;"></td><td style="background-color: #cccccc;"></td><td style="background-color: #cccccc;"></td><td style="background-color: #cccccc;"></td><td style="background-color: #cccccc;"></td><td style="background-color: #cccccc;"></td><td style="background-color: #cccccc;"></td><td style="background-color: #cccccc;"></td><td style="background-color: #cccccc;"></td><td style="background-color: #cccccc;"></td><td style="background-color: #cccccc;"></td><td style="background-color: #cccccc;"></td><td style="background-color: #cccccc;"></td><td style="background-color: #cccccc;"></td> </tr> <tr> <td></td> <td></td><td></td><td></td><td></td><td></td><td></td><td></td><td>P3</td><td>P2</td><td>P1</td><td>P0</td><td>0</td><td>0</td><td>0</td><td>1</td><td></td> </tr> </table> </div> <p style="text-align: right;">                 Setup Mode                  Command Status = OK                  Parameter Data             </p> <p>The meaning of Parameters P0~P4 is slave specific.</p>		15	14	13	12	11	10	9	8	7	6	5	4	3	2	1	0	IR n																									P3	P2	P1	P0	0	0	0	1	
	15	14	13	12	11	10	9	8	7	6	5	4	3	2	1	0																																				
IR n																																																				
								P3	P2	P1	P0	0	0	0	1																																					

**Example** Read the actual parameter data of the slave with address 27.

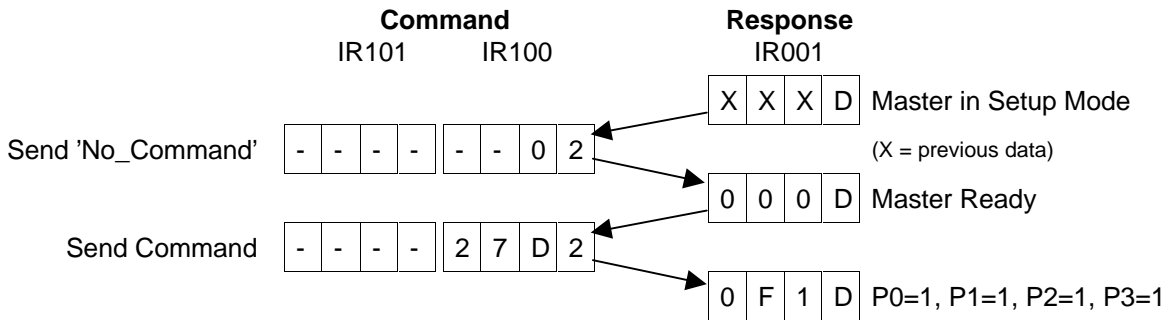

4-5-3-9 Write\_Parameter

**Function** Set the Parameter Bits of an actual slave connected to the AS-Interface network.

<b>Command Code</b>	F (1111)																																			
<b>Command Argument 1</b>	Slave address (2 digits BCD).																																			
<b>Command Argument 2</b>	Actual Parameter Data for slave [Command Argument 1]. 4 bits as below: <div style="text-align: center;"> <table style="border-collapse: collapse; margin: auto;"> <tr> <td style="padding-right: 5px;">15</td><td>14</td><td>13</td><td>12</td><td>11</td><td>10</td><td>9</td><td>8</td><td>7</td><td>6</td><td>5</td><td>4</td><td>3</td><td>2</td><td>1</td><td>0</td> </tr> <tr> <td colspan="13" style="text-align: center;">IR m+1</td> <td style="border: 1px solid black; padding: 2px;">P3</td> <td style="border: 1px solid black; padding: 2px;">P2</td> <td style="border: 1px solid black; padding: 2px;">P1</td> <td style="border: 1px solid black; padding: 2px;">P0</td> <td style="padding-left: 20px;">Parameter Data</td> </tr> </table> </div> <p>The meaning of Parameters P0~P4 is slave specific.</p>	15	14	13	12	11	10	9	8	7	6	5	4	3	2	1	0	IR m+1													P3	P2	P1	P0	Parameter Data	
15	14	13	12	11	10	9	8	7	6	5	4	3	2	1	0																					
IR m+1													P3	P2	P1	P0	Parameter Data																			
<b>Command Status</b>	<p>1 Command processed successfully.</p> <p>2 Error in processing the command (invalid argument value or Slave write error).</p> <p>other Master is busy.</p>																																			
<b>Command Return Value</b>	<p>Result of the Write_Parameter Command (error flag). If all error flags are off, and Command Status =1, the command was processed successfully. If not, the following flag indicate the type of error:</p> <div style="text-align: center;"> <table style="border-collapse: collapse; margin: auto;"> <tr> <td style="padding-right: 5px;">15</td><td>14</td><td>13</td><td>12</td><td>11</td><td>10</td><td>9</td><td>8</td><td>7</td><td>6</td><td>5</td><td>4</td><td>3</td><td>2</td><td>1</td><td>0</td> </tr> <tr> <td colspan="13" style="text-align: center;">IR n</td> <td style="border: 1px solid black; padding: 2px;">0</td> <td style="border: 1px solid black; padding: 2px;">0</td> <td style="border: 1px solid black; padding: 2px;">1</td> <td style="border: 1px solid black; padding: 2px;">0</td> <td style="border: 1px solid black; padding: 2px;">1</td> <td style="padding-left: 20px;">Setup Mode</td> </tr> </table> </div> <p style="text-align: right; margin-right: 20px;">Command Status = Error Slave not detected [SND]</p> <p>SND The slave specified by Command Argument 1 was not detected on the network.</p>	15	14	13	12	11	10	9	8	7	6	5	4	3	2	1	0	IR n													0	0	1	0	1	Setup Mode
15	14	13	12	11	10	9	8	7	6	5	4	3	2	1	0																					
IR n													0	0	1	0	1	Setup Mode																		

**Example** Set the actual parameter data for the slave with address 2 as P0=0, P1=1, P2=1, P3=0

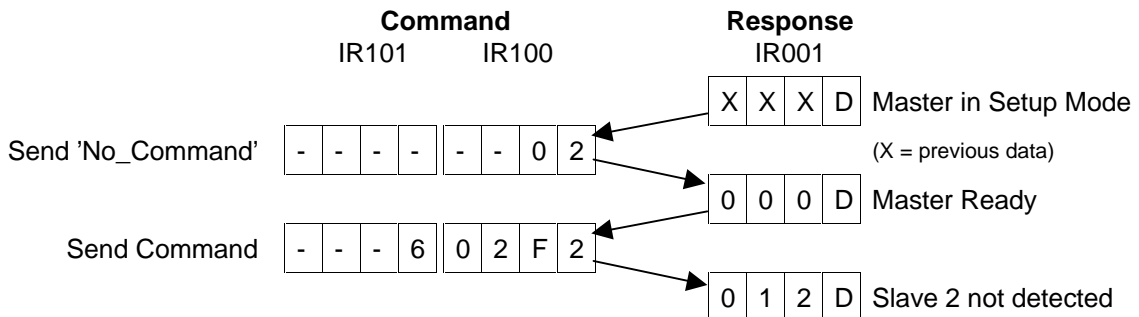

### 4-5-4 Exit Setup Mode

To exit from Setup Mode, set the Mode Control Bit (IR m.01) to 0, while the MOD switch remains OFF. The Master will return to Configuration Mode. It is not possible to switch from Setup Mode to Protected Mode by setting the MOD switch from OFF to ON while the Mode Control Bit is ON. This is to avoid conflicts when the PLC is programmed from a remote location, while the switches can be operated locally.

If the MOD switch is set from OFF to ON while in Setup Mode, the ERR LED will light to indicate that the requested mode change could not be made.

 **Caution**

The user is to make sure that when the AS-Interface master leaves Setup Mode, the appropriate output data for slaves 1~7 is available in IR m bits 04~15 and IR m+1 bits 00~15.

The output data for slaves 1~7 should be set to IR m and IR m+1 in the same PLC cycle in which the Mode Control Bit is reset to 0.

When the Mode Flag (IR n.00) is OFF, the updating of input data from slaves 1~3, in IR n bits 04~15, has resumed.





## 5 System Configuration

This section summarises several ways to set up a complete AS-Interface network.

5-1 AS-Interface Set-up Methods .....	50
5-2 Bottom-up Method .....	50
5-2-1 <i>Bottom-up, with addressing unit</i> .....	50
5-2-2 <i>Bottom-up, without addressing unit</i> .....	51
5-3 Top-down Method .....	51
5-3-1 <i>Top-down, with addressing unit</i> .....	51
5-3-2 <i>Top-down, without addressing unit</i> .....	52

## 5-1 AS-Interface Set-up Methods

There are two fundamentally different ways to build up an AS-Interface network:

1. Bottom-up.  
Actually construct the full network, then let the master unit detect what is connected and store this in the master's non-volatile memory as the projected configuration. This bottom-up method requires the full set of slaves to be operational at the time of configuration.
2. Top-down.  
Define the projected configuration off-line and store it in non-volatile memory, then attach the network and make sure it matches the projected configuration. This top-down method does not require the slaves to be present at the time of configuration.

## 5-2 Bottom-up Method

This is the simplest way to set up the AS-Interface network. The master will determine the configuration from the slaves detected on the AS-Interface line. This can be done with or without using a separate addressing unit.

Although this method will allow you to get the network in operation quickly, any mistake made in the actual configuration of slaves cannot easily be determined. Any combination of slaves detected on the actual network will be stored as projected configuration, and once in Protected Mode, the master will communicate with all these slaves, even if slaves of the wrong type or the wrong address have been installed. In that case it is likely that the mapping of slave I/O data to the PLC will be incorrect, but no configuration error will be indicated.

### 5-2-1 Bottom-up, with addressing unit

If a separate hand-held addressing unit is available, this is the fastest way to set up an AS-Interface system. Each slave's address is set while off-line, and once the slaves are installed, the master will detect them.

1, 2, 3...

1. Connect the AS-Interface line and power supply to the CQM1-ARM21.
2. Put the CQM1-ARM21 in Configuration Mode. (MOD switch OFF, Mode bit IR m.01 OFF).
3. Use a separate addressing unit to assign addresses to all slaves before installation.
4. Connect all slaves to the AS-Interface cable. When a slave is detected, the associated slave indicator LED on the CQM1-ARM21 will flash.
5. If necessary, set the slave parameters using Setup Mode (see 4-5-3-9, *Write\_Parameter*).
6. Toggle the SET switch (OFF→ON) to copy the actual configuration to the permanent configuration (Put the SET switch back to OFF position).
7. The CQM1-ARM21's slave indicators for the active slaves should be ON, none should flash, and the CERR LED should go OFF.
8. Put the CQM1-ARM21 in Protected Mode (MOD switch ON).

## 5-2-2 Bottom-up, without addressing unit

If no separate addressing unit is available, the CQM1-ARM21 can perform the task of assigning addresses to blank slaves. Since all slaves are factory-set to address 0, they need to be added and re-programmed one by one.

1, 2, 3...

1. Connect the AS-Interface cable and power supply to the CQM1-ARM21.
2. Put the master in Setup Mode (MOD switch OFF, Mode bit IR m.01 ON).
3. Connect one new slave, with address 0, to the AS-Interface cable. The master's 'slave 0' LED should flash.
4. Change the slave's address from 0 to the projected value (see 4-5-3-5, *Change\_Slave\_Address*); the CQM1-ARM21 will automatically recognise the slave at the new address, and the appropriate slave indicator LED should be ON.
5. If necessary, set the slave parameters (see 4-5-3-9, *Write\_Parameter*).
6. Repeat steps 3 - 5 for all slaves.
7. Toggle the SET switch (OFF→ON) to copy the actual configuration to the permanent configuration (Put the SET switch back to OFF position).
8. The slave indicator LEDs of the active slaves should be ON, none should flash, and the CERR LED should be OFF.
9. Put the CQM1-ARM21 in Protected Mode (MOD switch ON).

## 5-3 Top-down Method

This is the safest way to set up the AS-Interface network. The projected slave configuration can be defined in advance, and stored in the master unit. When installing the system, the user can easily verify if the actual slave configuration matches the projected configuration. If a wrong type of slave was installed, or a slave with the wrong address, a configuration error will be indicated. If there is no configuration error, the only possible type of error is that slaves are mounted on the wrong position on the line.

If a separate addressing device is used to set the slave addresses off-line, no configuration work is required in the field.

### 5-3-1 Top-down, with addressing unit

If an addressing unit is available, the whole AS-Interface slave network and the master can be prepared separately. When the master is connected to the network, any errors in the configuration can easily be found.

1, 2, 3...

1. Apply power to the PLC and to the ASI+ and ASI- terminals. During off-line preparation, it is possible to temporarily use a standard 24 V DC power supply (100 mA min.) instead of an AS-Interface power supply. The ARM21's RUN LED will flash as long as no slaves are detected.
2. Put the master in Setup Mode (MOD switch OFF, Mode bit IR m.01 ON).
3. Define each projected slave's address and type (see 4-5-3-3, *Set\_Permanent\_Configuration*). If necessary, set each slave's parameters (see 4-5-3-7, *Set\_Permanent\_Parameter*).

4. Put the CQM1-ARM21 in Protected Mode (Mode Bit OFF, then MOD switch ON). The master will restart.
5. Prepare the AS-Interface network separately, using an addressing device to set all slaves to the projected addresses.
6. Connect the AS-Interface power supply, cable and slaves to the CQM1-ARM21; If all slaves have been configured correctly, their LED indicators on the master should light, none should flash, and the CER LED should go OFF.

### 5-3-2 Top-down, without addressing unit

If no separate addressing unit is available, the CQM1-ARM21 can perform the task of assigning addresses to blank slaves. Since all slaves are factory-set to address 0, they need to be added and re-programmed one by one.

1, 2, 3...

1. Connect the AS-Interface cable and power supply to the CQM1-ARM21.
2. Put the master in Setup Mode (MOD switch OFF, Mode bit IR m.01 ON).
3. Define each projected slave's address and type (see 4-5-3-3, *Set\_Permanent\_Configuration*). If necessary, set each slave's parameters (see 4-5-3-7, *Set\_Permanent\_Parameter*).
4. Connect one new slave, with address 0, to the AS-Interface cable.
5. Change the slave's address from 0 to the projected value (see 4-5-3-5, *Change\_Slave\_Address*).
6. If necessary, set the slave parameters (see 4-5-3-9, *Write\_Parameter*).
7. Repeat steps 4-6 for all slaves.
8. If all slaves have been configured correctly, their LED indicators should light, none should flash, and the CER LED should go OFF.
9. Put the CQM1-ARM21 in Protected Mode (Mode Bit OFF, then MOD switch ON). The master will restart.

## 6 Troubleshooting and maintenance

This section describes the troubleshooting procedures and maintenance operations needed to keep the AS-Interface Master Unit operating properly.

6-1	Error indicators .....	54
6-2	Troubleshooting .....	54
	6-2-1 PLC Errors .....	54
	6-2-2 Start-up Problems .....	55
	6-2-3 Configuration Problems.....	55
	6-2-4 AS-Interface Communication Problems.....	57
6-3	Maintenance .....	58
	6-3-1 Cleaning.....	58
	6-3-2 Inspection.....	58

## 6-1 Error indicators

The CQM1-ARM21 uses the following means of error indication:

- LED indicators: RUN, ERR, APF, CER, Slave status LEDs.  
See 2-1-2, *LED Indicators*.
- Status Flags: Config\_OK, Normal\_Operation, System Error.  
See 4-4-1, *Status Flags*.

In case of malfunctions, check the status of all LEDs and Status Flags, and refer to the troubleshooting tables in this chapter to determine the cause.

## 6-2 Troubleshooting

Possible problems have been divided in the following categories:

- PLC Errors
- Start-up problems
- Configuration problems
- AS-Interface communication problems

### 6-2-1 PLC Errors

Mounting the AS-Interface master unit in a CQM1 PLC system can cause the following errors to be indicated by the CQM1 CPU unit.

If the CQM1 CPU fails to start up correctly after power-on, the RUN LED of the CQM1-ARM21 will blink to indicate that its initialisation could not be completed.

Symptoms	Possible cause	Possible remedy
I/O BUS ERR FALS C0 CPU RUN LED remains OFF CPU ERR LED is ON	An I/O unit, or the end cover, is not connected properly.	Turn the PLC's power OFF and check for loose units. Lock all units together with the top and bottom sliders and re-apply the power.
	An I/O unit is defective.	Turn the PLC's power OFF and one by one remove the I/O units until the error disappears. Replace the unit causing the error.
I/O UNIT OVER FALS E1 CPU RUN LED remains OFF CPU ERR LED is ON	The number of I/O words on the installed I/O units exceeds the maximum for this CPU type.	Check the ARM21's switch settings to determine the number of I/O words required by the Unit, and compare with the maximum allowed value for the used CPU. Turn the PLC's power OFF, then either: <ul style="list-style-type: none"> <li>• Reduce the ARM21's I/O allocation.</li> <li>• Remove I/O units from the CQM1 system.</li> <li>• Select a CPU type with larger I/O capacity.</li> </ul> See also 4-1, <i>PLC Settings</i> , for PLC CPU types that support 31 AS-Interface slaves.

### 6-2-2 Start-up Problems

If the CQM1-ARM21 does not appear to enter its normal mode of operation, check for the following symptoms.

Symptom	Possible cause	Possible remedy
No LEDs are ON or flashing	The PLC's power is OFF.	Apply power to the PLC's power supply unit according to its specifications.
	The CQM1-ARM21 is defective.	Replace the CQM1-ARM21.
RUN LED is flashing and Normal_Operation Flag is OFF	The CQM1-ARM21 is initialising after power-on or due to a change to Protected Mode.	Normal behaviour, the flashing should stop within several seconds.
	There are no AS-Interface slaves on the line. The master will continue scanning for slaves in the initialisation phase.	Install AS-Interface slaves.
	The CQM1-ARM21 cannot complete its power-on self-check sequence. Unit is defective.	Replace the CQM1-ARM21
RUN LED is flashing and APF LED is ON, System Error Flag (IR n.01) is ON.	Insufficient power on the AS-Interface line to start communications.	Check that the voltage on the AS-Interface line, at the master's terminals, is between 23.5 and 31.5 V DC. Inspect the AS-Interface power supply and replace if necessary. Note: the Unit does not check for overvoltage, nor can it distinguish AS-Interface power supplies from standard types.

### 6-2-3 Configuration Problems

When encountering problems during the configuration of an AS-Interface network, check the table below.

Symptom	Possible cause	Possible remedy
CER LED ON Configuration_OK Flag OFF	The detected configuration on the AS-Interface bus differs from the stored permanent configuration, or a slave with address 0 is detected.	If the actual configuration is believed to be correct, store the detected configuration by toggling the SET switch OFF→ON. If the permanent configuration is believed to be correct, determine the permanent configuration data by using the Get_Permanent_Configuration command, and build the actual configuration accordingly.
Store Configuration (SET switch OFF→ON) does not extinguish CER LED.	Storing the detected configuration is not allowed in Protected Mode	Put the SET switch in OFF position, then set the MOD switch OFF (Configuration Mode). Store the configuration by toggling the SET switch ON, then return to Protected Mode by setting the MOD switch ON. Note: This will restart the master.
ERR LED ON	A change to Protected Mode, requested by toggling the MOD switch OFF→ON, is not allowed because: - A slave with address 0 was detected in Configuration Mode. - The unit is in Setup Mode (Mode Bit is ON).	Set the MOD switch back to OFF, then: - Remove the slave with address 0 - Turn the Mode Bit (IR m.01) OFF. and set the Unit to Protected Mode by toggling the MOD switch OFF→ON.

Configuration Problems (continued)

Unrecognisable response to a Setup Mode command	Command was not preceded by No_Command	See 4-5-3, <i>Commands</i> , for the correct sequence of operation.
	Unit failed to enter Setup Mode because MOD switch is ON (Protected Mode).	Check if the Mode Bit (IR n.00) is ON. If not, first set the MOD switch to OFF (Configuration Mode) Then select Setup Mode by setting the Mode Flag (IR m.01) ON.
Error response to a Setup Mode command affecting Permanent Data	Invalid command argument, slave address out of range.	See 4-5-3, <i>Commands</i> , for the correct usage of Setup Mode Commands.
	Non-volatile memory in the Unit (EEPROM) is defective.	Replace the Unit.
Error response to a Setup Mode command affecting actual slaves	Invalid command argument, unacceptable slave address.	See 4-5-3, <i>Commands</i> , for the correct usage of Setup Mode Commands.
	Communication on AS-Interface line disrupted or slave defective.	Check the AS-Interface line, power supply and affected slave(s) for malfunctions or bad connections.
	Slave address is above the limit set by the CH switches.	Use only slave addresses within the range selected by the CH switches (see 2-1-3, <i>Switches</i> ).
AUP LED is ON, but the defective slave cannot be replaced by a blank slave	The new slave does not have the same ID Code and/or I/O Configuration as stored in the permanent configuration data.	Replace with the correct type of slave, or add the new slave while in Configuration Mode or Setup Mode.
	The new slave has an address unequal to 0 or the address of the slave to be replaced.	Correct the slave's address with a hand-held addressing device, or by using the Setup Mode command Change_Slave_Address.
A slave has failed, but the AUP LED remains OFF	The master is in Configuration Mode.	Correct the new slave's address with a hand-held addressing device, or by using the Setup Mode command Change_Slave_Address.
	More than one slave has failed (check the slave status LED indicators).	Set the new slaves' addresses with a hand-held addressing device, or by using the Setup Mode command Change_Slave_Address.



### 6-2-4 AS-Interface Communication Problems

After successfully configuring the AS-Interface network, the following symptoms may indicate errors in the proper operation.

Symptom	Possible cause	Possible remedy
Slave status LED is OFF while the slave is connected	Slave is not included in the permanent configuration, and Unit is in Protected Mode.	Add the slave to the permanent configuration in Configuration Mode (SET switch), or in Setup Mode (Set_Permanent_Configuration command), then resume Protected Mode.
	Slave address is above the limit set by the CH switches.	Use only slave addresses within the range selected by the CH switches (see 2-1-3, <i>Switches</i> ).
Slave status LED is flashing	Slave is included in the permanent configuration, but not active in data exchange.	Check the data exchange with the slave via the allocated IR bits. If necessary, replace the slave.
	Slave 0 LED flashing indicates that a slave with address 0 is detected.	Assign a valid address, or remove the slave with address 0.
ERR LED ON	Data transmission on the AS-Interface line is corrupted.	Check the installation of the AS-Interface cable for physical damage, excessive length, routing near sources of strong interference
	Change of operation mode is not allowed.	See <i>Configuration Problems</i>
	The CQM1-ARM21 is defective.	Replace the Unit.
APF LED ON	The AS-Interface power supply is not connected or defective.	Check the power supply and its connections. Replace if necessary.
	The current consumed by the AS-Interface master and slaves exceeds the rating of the power supply.	Replace the AS-Interface power supply by a type with higher capacity, or install repeaters and a power supply for each section.
System Error Flag ON	ERR LED or APF LED is lit.	See above.

## 6-3 Maintenance

This section describes the routine cleaning and inspection recommended as regular maintenance.

### 6-3-1 Cleaning

Clean the AS-Interface Master Unit regularly as described below in order to keep it in its optimal operating condition.

- Wipe the Unit with a dry, soft cloth for regular cleaning.
- When a spot cannot be removed with a dry cloth, dampen the cloth with a neutral cleanser, wring out the cloth, and wipe the Unit.
- A smudge may retain on the Unit from gum, vinyl, or tape that was left on for a long time. Remove the smudge when cleaning.

 **Caution** Never use volatile solvents such as paint thinner or benzene or chemical wipes. These substances could damage the surface of the Unit.

### 6-3-2 Inspection

Be sure to inspect the system periodically to keep it in its optimal operating condition. In general, inspect the system once every 6 to 12 months, but inspect more frequently if the system is used with high temperature or humidity or under dirty / dusty conditions.

#### Inspection Equipment

Prepare the following equipment before inspecting the system.

##### Required Equipment

Have a standard and Philips-head screwdriver, multimeter, alcohol, and a clean cloth.

##### Equipment that could be needed

Depending on the system conditions, a synchroscope, oscilloscope, thermometer, or hygrometer (to measure humidity) might be needed.

#### Inspection Procedure

Check the items in the following table and correct any items that are below standard.

	Item	Standard	Equipment
Environmental conditions	Ambient temperature	0°C to 55°C	Thermometer
	Ambient humidity	10% to 90%	Hygrometer
	Dust/dirt accumulation	None	---
Installation	Are the Units installed securely?	No looseness	---
	Are the communications connectors fully inserted?	No looseness	---
	Are the external wiring screws tight?	No looseness	---
	Are the connecting cables undamaged?	No damage	---

## 7 Appendices

This section contains additional information concerning AS-Interface specifications and terminology.

Appendix A AS-Interface PICS.....	60
Appendix B AS-Interface Slave Profiles .....	63
Appendix C AS-Interface terminology and abbreviations .....	64

# Appendix A

## AS-Interface PICS

(Protocol Implementation Conformance Statement)

Vendor:	Omron Corporation
Product name:	CQM1-ARM21
Order No.:	CQM1-ARM21
Release:	1.0
Master Profile:	M0 in Normal Operation mode, additional functions in Setup mode
Date:	01/02/1999

### List of implemented functions in Normal Operation mode:

No.	Function or call at host interface	M0	Implementation	Section
1	Image, Status = Read_IDI ()	X	to CPU via I/O bus (IR n..)	4-4-3
2	Status = Write_ODI (Image)	X	from CPU via I/O bus (IR m..)	4-4-3
3	Status = Set_Permanent_Parameter (Addr, Param)	-		
4	Param, Status = Get_Permanent_Parameter (Addr)	-		
5	Status, RParam = Write_Parameter (Addr, Param)	-		
6	Status, Param = Read_Parameter (Addr)	-		
7	Status = Store_Actual_Parameters ()	X	SET switch (SW 6)	2-1-3
8	Status = Set_Permanent_Configuration (Addr, Config)	-		
9	Status, Config = Get_Permanent_Configuration (Addr)	-		
10	Status = Store_Actual_Configuration ()	X	SET switch (SW 6)	2-1-3
11	Status, Config = Read_Actual_Configuration (Addr)	-		
12	Status = Set_LPS (List31)	-		
13	Status, List31 = Get_LPS ()	-		
14	Status, List31 = Get_LAS ()	-		
15	Status, List32 = Get_LDS ()	-		
16.0	Status, Flags = Get_Flags ()	-		
16.1	Status, Flag = Get_Flag_Config_OK ()	X	CER LED, Status Flag n.03	2-1-2, 4-4-1
16.2	Status, Flag = Get_Flag_LDS.0 ()	-		
16.3	Status, Flag = Get_Flag_Auto_Address_Assign ()	-		
16.4	Status, Flag = Get_Flag_Auto_Prog_Available ()	X	AUP LED	2-1-2
16.5	Status, Flag = Get_Flag_Configuration_Active ()	X	CM LED	2-1-2
16.6	Status, Flag = Get_Flag_Normal_Operation_Active ()	X	Status Flag n.02	4-4-1
16.7	Status, Flag = Get_Flag_APF ()	X	APF LED, Status Flag n.01	2-1-2, 4-4-1
16.8	Status, Flag = Get_Flag_Offline_Ready ()	-		
17	Status = Set_Operation_Mode (Mode)	X	MOD Switch (SW 5)	2-1-3
18	Status = Set_Offline_Mode (Mode)	-		
19	Status = Activate_Data_Exchange (Mode)	-		
20	Status = Change_Slave_Address (Addr1, Addr2)	-		
21.1	Status = Set_Auto_Address_Enable (Mode)	X	Control Bit m.00	4-4-2
21.2	Mode = Get_Auto_Address_Enable ()	-		
22.1	Status, Resp = Cmd_Reset_AS-Interface_Slave (Addr, RESET)	-		
22.2	Status, Resp = Cmd_Read_IO_Configuration (Addr, CONF)	-		
22.3	Status, Resp = Cmd_Read_Identification_Code (Addr, IDCOD)	-		
22.4	Status, Resp = Cmd_Read_Status (Addr, STAT)	-		
22.5	Status, Resp = Cmd_Read_Reset_Status (Addr, STATRES)	-		
22.6	Status, Resp = Cmd_R1 (Addr, R1CODE)	-		

**List of implemented functions in Setup mode:**

No.	Function or call at host interface		Implementation	Section
1	Image, Status = Read_IDI ()	(X)	Partially suspended	4-5
2	Status = Write_OD (Image)	(X)	Partially suspended	4-5
3	Status = Set_Permanent_Parameter (Addr, Param)	X	Setup Command B	4-5-3-7
4	Param, Status = Get_Permanent_Parameter (Addr)	X	Setup Command 9	4-5-3-6
5	Status, RParam = Write_Parameter (Addr, Param)	X	Setup Command F	4-5-3-9
6	Status, Param = Read_Parameter (Addr)	X	Setup Command D	4-5-3-8
7	Status = Store_Actual_Parameters ()	X	SET switch (SW 6)	2-1-3
8	Status = Set_Permanent_Configuration (Addr, Config)	X	Setup Command 3	4-5-3-3
9	Status, Config = Get_Permanent_Configuration (Addr)	X	Setup Command 1	4-5-3-2
10	Status = Store_Actual_Configuration ()	X	SET switch (SW 6)	2-1-3
11	Status, Config = Read_Actual_Configuration (Addr)	X	Setup Command 5	4-5-3-4
12	Status = Set_LPS (List31)	-		
13	Status, List31 = Get_LPS ()	-		
14	Status, List31 = Get_LAS ()	-		
15	Status, List32 = Get_LDS ()	-		
16.0	Status, Flags = Get_Flags ()	-		
16.1	Status, Flag = Get_Flag_Config_OK ()	X	CER LED, Status Flag n.03	2-1-2, 4-4-1
16.2	Status, Flag = Get_Flag_LDS.0 ()	-		
16.3	Status, Flag = Get_Flag_Auto_Address_Assign ()	-		
16.4	Status, Flag = Get_Flag_Auto_Prog_Available ()	X	AUP LED	2-1-2
16.5	Status, Flag = Get_Flag_Configuration_Active ()	X	CM LED	2-1-2
16.6	Status, Flag = Get_Flag_Normal_Operation_Active ()	X	Status Flag n.02	4-4-1
16.7	Status, Flag = Get_Flag_APF ()	X	APF LED, Status Flag n.01	2-1-2, 4-4-1
16.8	Status, Flag = Get_Flag_Offline_Ready ()	-		
17	Status = Set_Operation_Mode (Mode)	X	MOD Switch (SW 5)	2-1-3
18	Status = Set_Offline_Mode (Mode)	-		
19	Status = Activate_Data_Exchange (Mode)	-		
20	Status = Change_Slave_Address (Addr1, Addr2)	X	Setup Command 7	4-5-3-5
21.1	Status = Set_Auto_Adress_Enable (Mode)	X	Control Bit m.00	4-4-2
21.2	Mode = Get_Auto_Adress_Enable ()	-		
22.1	Status, Resp = Cmd_Reset_AS-Interface_Slave (Addr, RESET)	-		
22.2	Status, Resp = Cmd_Read_IO_Configuration (Addr, CONF)	-		
22.3	Status, Resp = Cmd_Read_Identification_Code (Addr, IDCOD)	-		
22.4	Status, Resp = Cmd_Read_Status (Addr, STAT)	-		
22.5	Status, Resp = Cmd_Read_Reset_Status (Addr, STATRES)	-		
22.6	Status, Resp = Cmd_R1 (Addr, R1CODE)	-		

Key to the symbols for column 3:

	meaning
X	implemented
-	not available

**AS-Interface cycle time**

One activated slave : 322 μs

2 to 31 activated slaves: 168 + (number of activated slaves \* 154) μs



## Appendix B

### AS-Interface Slave Profiles

An overview of AS-Interface slave profiles and their combinations of configuration (IO code) and profile identification (ID code) is given below.

AS Interface profiles		ID code																
		0	1	2	3	4	5	6	7	8	9	A	B	C	D	E	F	
I/O Code	0	I,I,I,I	X.0	0.1	Reserved													No Profile X:F
	1	I,I,I,O		1.1														
	2	I,I,I,B																
	3	I,I,O,O		3.1														
	4	I,I,B,B																
	5	I,O,O,O																
	6	I,B,B,B																
	7	B,B,B,B		7.1														
	8	O,O,O,O	8.1															
	9	O,O,O,I	R															
	A	O,O,O,B	X.0															
	B	O,O,I,I	R	B.1														
	C	O,O,B,B	X.0															
	D	O,I,I,I	R	D.1														
	E	O,B,B,B	X.0															
	F	T,T,T,T	Not Used															

(configuration: I = input, O = output, B = bidirectional, T = tristate; profiles: V = virgin, R = reserved)

Defined slave profiles exist for:

- I/O=X    ID=F    Free profiles
- I/O=X    ID=0    Remote I/O ports
- I/O=0    ID=1    Two dual-signal sensors
- I/O=3    ID=1    One dual-signal sensor, one dual actuator
- I/O=8    ID=1    Two dual-signal actuators
- I/O=1    ID=1    Single sensor with extended control
- I/O=7    ID=1    Interface for the transfer of 6 to 18-bit signals
- I/O=7    ID=2    Extended slave profile for the transmission of 6 to 21-bit signals
- I/O=B    ID=1    Dual actuator with feedback
- I/O=D    ID=1    Single actuator with monitoring

Virgin slaves before assembly at the manufacturer have no particular configuration. They carry I/O=F and ID=F. The same codes I/O=F and ID=F are stored in the volatile memory of a slave, if there was an error in transferring the codes from the non-volatile to the volatile memory.

# Appendix C

## AS-Interface terminology and abbreviations

### Symbols and abbreviations

<b>APF</b>	AS-Interface <b>P</b> ower <b>F</b> ail
<b>APM</b>	Alternate <b>P</b> ulse <b>M</b> odulation
<b>APO</b>	AS-Interface <b>P</b> ower <b>O</b> n
<b>AS-Interface</b>	Actuator <b>S</b> ensor <b>I</b> nterface (the term ASI is used, but not officially approved)
<b>CB</b>	<b>C</b> ontrol <b>B</b> it
<b>CD</b>	<b>C</b> onfiguration <b>D</b> ata
<b>CDI</b>	<b>C</b> onfiguration <b>D</b> ata <b>I</b> mage
<b>EB</b>	<b>E</b> nd <b>B</b> it
<b>IDI</b>	<b>I</b> nput <b>D</b> ata <b>I</b> mage
<b>LAS</b>	<b>L</b> ist of <b>A</b> ctive <b>S</b> laves
<b>LDS</b>	<b>L</b> ist of <b>D</b> etected <b>S</b> laves
<b>LPS</b>	<b>L</b> ist of <b>P</b> rojected <b>S</b> laves
<b>ODI</b>	<b>O</b> utput <b>D</b> ata <b>I</b> mage
<b>PB</b>	<b>P</b> arity <b>B</b> it
<b>PCD</b>	<b>P</b> ermanent <b>C</b> onfiguration <b>D</b> ata
<b>PI</b>	<b>P</b> arameter <b>I</b> mage
<b>PP</b>	<b>P</b> ermanent <b>P</b> arameter
<b>PSK</b>	<b>P</b> hase <b>S</b> hift <b>K</b> eying
<b>ST</b>	<b>S</b> tart <b>B</b> it
<b>TBit</b>	<b>B</b> it <b>t</b> ime
<b>0x00</b>	hexadecimal representation of binary values, e.g.: 0x1F = 31 , 0xF = 15

### AS-Interface Glossary

<b>active slave</b>	A slave connected to the AS-Interface line and capable to communicate properly.
<b>address assignment</b>	Replacement of the existing address of the AS-Interface slave with a new address.
<b>address</b>	An address out of the address space of the AS-Interface slaves (0...31).
<b>AS-Interface</b>	Actuator Sensor Interface: a set of interfaces and a serial communication method to connect low-voltage switch gear, control gear, and other simple elements with a controlling device.
<b>AS-Interface cycle</b>	A set of up to 33 transactions. A transaction may - in case of detected failure - include one message retransmission.
<b>AS-Interface input</b>	Physical or logical slave input port.
<b>AS-Interface line</b>	Two-wire line for transferring information and power to the AS-Interface slaves and the AS-Interface master.
<b>AS-Interface network</b>	Network composed of an AS-Interface control circuit, interfaces and switching elements, e.g. master, slaves, power supply, cable, taps.
<b>AS-Interface output</b>	Physical or logical slave output port.



<b>AS-Interface power supply</b>	A special power supply combining a DC supply and a decoupling circuit needed in an AS-Interface network.
<b>bit time</b>	Time to send one bit on the AS-Interface line.
<b>configuration data</b>	The value of the I/O configuration and the identification code of a specific slave.
<b>configuration data image</b>	The image of the configuration data of all slaves, stored in the AS-Interface master.
<b>data exchange phase</b>	Period of time when the master sends values of the output data image to the slaves and receives input data from the slaves.
<b>decoupling circuit</b>	A part of the AS-Interface power supply for decoupling the DC source and for conditioning the physical data transmission within the AS-Interface network.
<b>detection phase</b>	Period of time when the execution control of the master tries to find all slaves connected and operating. All slaves found are listed in the list of detected slaves.
<b>execution control</b>	Master function that controls the message exchange and provides several functions to the host interface.
<b>host</b>	The user of the master. Users may be, for example, a programmable logic controller, a personal computer, a gateway, or a human operator.
<b>host interface</b>	The logical interface between the master and the host.
<b>I/O-configuration (I/O-code)</b>	Set of four bits which defines the direction of data flow at the slave I/O ports.
<b>identification code (ID-code)</b>	Set of four bits which defines the type of slave for a given I/O-configuration.
<b>input data image</b>	Input data stored in the master, received from the slaves.
<b>list of active slaves</b>	A list of all slaves at the AS-Interface line that are activated and capable to communicate properly with the master. The list is available in the master.
<b>list of detected slaves</b>	A list of all slaves actually detected by the master. The list is available in the master.
<b>list of projected slaves</b>	A list of all configured slaves of the interface system as the target configuration. The list is available in the master and it includes the configuration data of all configured slaves.
<b>master</b>	Control unit on the AS-Interface line that communicates serially with the slaves.
<b>master pause</b>	The time between the last bit of a master request and the first bit of the slave response at the master.
<b>master request</b>	Message sent from the master to a single slave.
<b>non-volatile data</b>	Data that remain unchanged after power interruption.
<b>operation address</b>	Address of the AS-Interface slave different from the zero address.
<b>output data image</b>	Output data stored in the master to be transferred to the AS-Interface slaves.
<b>parameter image</b>	Parameters (sets of 4 bits) that define the functionality of all the different slaves in the AS-Interface network.
<b>slave</b>	A stand alone device or part of another device that provides an interface to the AS-Interface line and communicates with the master.
<b>slave pause</b>	The time between the last bit of a slave response and the start of sending the first bit of the next master request, measured at the master ports.
<b>slave response</b>	Answer that is sent to the master by the slave after a master request has been received and processed without error.
<b>transaction</b>	A transaction comprises a master request and a slave response.
<b>transmission control</b>	Master function that controls the data transmission, transmission pauses and retransmissions in case of failures (e.g., transmission failures, missing response from the slave, invalid response received, ...)
<b>zero address</b>	Special address reserved for the online assignment of a new address to an AS-Interface slave.



---

## Index

---

### A

APF ..... See Indicators  
AS-International ..... 2  
AUP ..... See Indicators  
Auto-address ..... 29, 32  
Auto-programming ..... 11, 29

### B

Bits  
    Control ..... See Control bits  
    I/O ..... See Inputs, Outputs  
Bus  
    Cable ..... 3, 15  
    Length ..... 4

### C

Cable ..... 3, 15  
CER ..... See Indicators  
CH ..... See Switches  
CM ..... See Indicators  
Command area ..... 34  
Commands ..... 27, 35  
    Change\_Slave\_Address ..... 41  
    Get\_Permanent\_Configuration ..... 38  
    Get\_Permanent\_Parameter ..... 43  
    No\_Command ..... 37  
    Read\_Actual\_Configuration ..... 40  
    Read\_Parameter ..... 45  
    Set\_Permanent\_Configuration ..... 39  
    Set\_Permanent\_Parameter ..... 44  
    Write\_Parameter ..... 46  
Communication  
    Problems ..... 57  
    Specification ..... See Specification, AS-Interface  
Configuration  
    Functions ..... 18, 35  
    Mode ..... See Mode  
    Network ..... 50-52  
    Problems ..... 55  
    Store ..... 13, 50-52  
Connector ..... 14, 18

Control Bits ..... 32  
    Auto\_address\_disable ..... 32  
    Mode ..... 28, 32, 35, 47  
Cover, Front ..... 10  
Cycle time  
    AS-Interface ..... 6, 20, 33  
    PLC ..... 20

### D

Data decoupling ..... 3  
Dimensions ..... 10, 19  
DM setting ..... 26

### E-F

EMC ..... See Installation  
EN 50295 ..... 18  
ERR ..... See Indicators  
Error  
    Indicators ..... 11, 54  
    Response error types ..... 6  
    Troubleshooting ..... 54  
Flags ..... See Status Flags

### G-H

Grounding ..... See Installation  
Humidity ..... See Installation

### I-J

I/O  
    Allocation ..... 12, 26, 31, 33  
    Response Time ..... 21  
Indicators, LEDs ..... 11, 18, 54  
    APF ..... 11, 55, 57  
    AUP ..... 11, 29, 56  
    CER ..... 11, 29, 50-55  
    CM ..... 11, 13, 28  
    ERR ..... 11, 29, 47, 50-57  
    RUN ..... 11, 51, 54-55  
    0-15, +16 ..... 12  
Inputs ..... 33

---

## Index

---

Installation ..... 14  
  EMC ..... xiv, 18  
  Grounding ..... xii  
  Humidity ..... xii, 18, 58  
  Temperature ..... xii, 14, 18, 58

### K-L

LEDs ..... See Indicators

### M-N

Maintenance ..... 58  
Master ..... 3  
  Data structure ..... 27  
  Profiles ..... 7  
  Request ..... 5  
MOD ..... See Switches  
Mode  
  Configuration ..... 7, 11, 28  
  Protected ..... 7, 11, 28  
  Setup ..... 11, 28, 34, 47

### O

Outputs ..... 33

### P-Q

PLC  
  CPU types ..... 26  
  Errors ..... 54  
Power Supply  
  AS-Interface ..... 3, 14, 15, 18, 31  
  PLC ..... 14, 18, 54  
Profiles  
  Masters ..... 7  
  Slaves ..... 3, 8  
Protected Mode ..... See Mode

### R

Response area ..... 36  
Response time ..... 19, 21  
Retransmission ..... 20  
RSV ..... See Switches  
RUN ..... See Indicators

### S

SET ..... See Switches  
Setup Mode ..... See Mode  
Slave  
  Address ..... 3  
  Indicators ..... 12  
  IO/ID codes, Profiles ..... 3, 8, 29, 63  
  I/O data ..... 33  
Response ..... 5  
Specifications  
  AS-Interface ..... 2, 18, 60  
  Bus cable ..... 3  
  Master Unit ..... 18  
Start-up problems ..... 55  
Status Flags ..... 31  
  Configuration OK ..... 29, 32  
  Mode ..... 28, 31, 35, 47  
  Normal Operation ..... 32  
  System Error ..... 31  
Store configuration ..... 13  
Switches ..... 12, 18  
  SET ..... 13, 27  
  MOD ..... 13, 28, 34, 47  
  RSV ..... 13  
  CH ..... 12, 31

### T-Z

Temperature ..... See Installation  
Time  
  Bus cycle ..... See Cycle Time  
  I/O response ..... 21  
  PLC cycle ..... See Cycle Time  
Troubleshooting ..... See Error





**Regional Headquarters**

**OMRON EUROPE B.V.**

Wegalaan 67-69

NL-2132 JD Hoofddorp

The Netherlands

Tel : +31 (0)23 568 1300

Fax : +31 (0)23 568 1388

# OMRON

**Authorized Distributor:**