

# Guardmaster<sup>®</sup> Ensign

HINGE OPERATED SAFETY INTERLOCK SWITCH  
SCHARNIER-SICHERHEITSSCHALTER  
CAPTEUR DE SECURITE A CHARNIERE



## INSTALLATION INSTRUCTIONS

## MONTAGEANLEITUNG

## NOTICE D'INSTALLATION

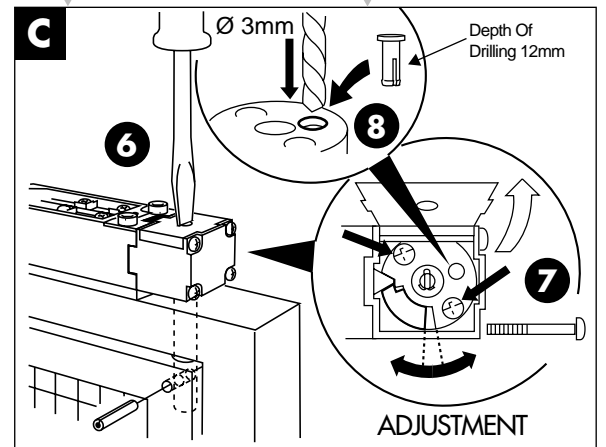
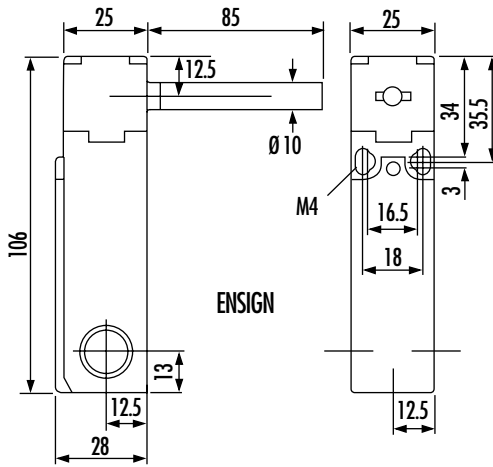
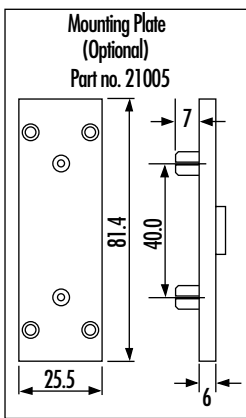
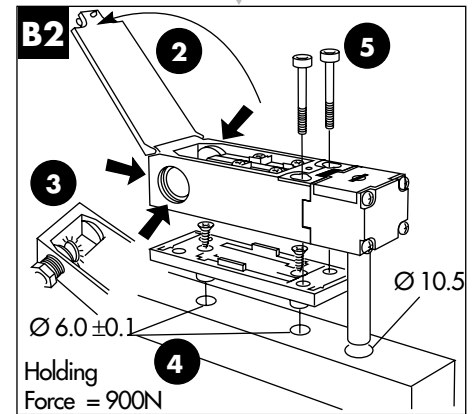
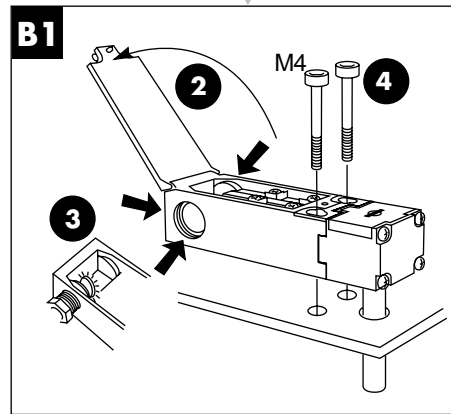
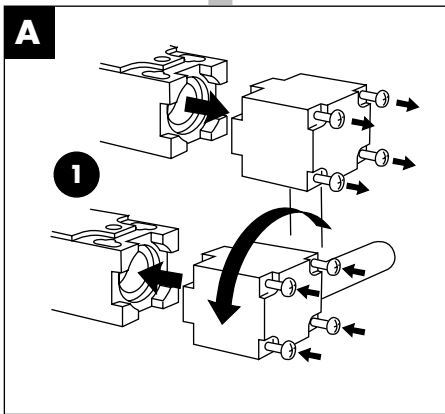

**!** The switch head screws must be fully tightened before the switch is connected to the machine control circuit.  
Die Schrauben am Schalterkopf müssen voll angezogen sein, bevor der Schalter an den Steuerkreis der Maschine angeschlossen wird.  
Les vis de la tête du capteur doivent être serrées avant que le capteur soit connecté au circuit de contrôle de la machine.

### INFORMATION IN REGARD TO UL508

Use copper conductors only.  
Use polymeric conduit only.  
End of line device.  
Terminal tightening torque 9in./lbs.  
When used in elevated ambients, temperature rating of field wiring shall not be less than ambient.  
Electrical spec of rating code A300.  
Max current: 120V AC - make 60A, break 6A.  
240V AC - make 30A, break 3A.  
Max. V/A: make 7200, break 720.



Conduit entry	M16	Pg9	1 N/C 24 - 23	version ECS1
Part Number	22001	22003	1N/O 12 - 11	
— GUARD CLOSED —				
Conduit entry	M16	Pg9	2 N/C 22 - 21	version ECS2
Part Number	22002	22004	12 - 11	

**ATTENTION:** The minimum operating angle for positive opening of the unadjusted cam mechanism is 11°. The cam can be adjusted down to a minimum angle of 3° and after adjustment must be fixed using the pin.



**ACHTUNG:** Der minimale Schaltwinkel bis zur Zwangsöffnung des nicht-justierten Nockenmechanismus beträgt 11°. Der Nocken kann auf einen minimalen Winkel von 3° justiert werden. Nach Justierung ist eine Fixierung mit dem Stift vorzunehmen.

**ATTENTION:** L'angle minimum d'opération pour l'ouverture d'un mécanisme à came mal ajusté est de 11°. La came peut être ajustée jusqu'à un angle minimum de 3° et doit ensuite être fixée à l'aide de la "punaise".



**English**

Conforming to standards	EN60947-5-1, PrEN1088 GS-ET-15, BS5304
Safety contacts - version ECS1	1 N/C positive break 
version ECS2	2 N/C positive break
Utilization cat.	AC 15
a.c. (Ue)	500V 250V 100V
(Ie)	1A 2A 5A
d.c.	250V 0.5A, 24V 2A
Thermal current (Ith)	10A
Safety contact gap	>2 x2mm
Rtd. insulation voltage	(Ui) 500V
Rtd. Impulse withstand voltage	(Uimp) 2500V
Auxiliary contacts	1N/O (version ECS1)
Pollution degree	3
Shaft rotation to achieve contact operation	Max 11°, Min 3° (adjustable)
Break contact min. force	8 cNm
Case material	Self extinguishing glass reinforced Polyester. 
Actuator shaft	Stainless steel
Protection	IP67
Conduit entry	3 x M16 / 3 x Pg9
Operating temperature	-25° to + 80°C
Fixing	2 x M4
Mounting	Any position
Cleaning	May be high pressure steam cleaned
Mechanical life	>1 x 10 <sup>6</sup>

**Deutsch**

Vorschriften	EN60947-5-1, PrEN1088 GS-ET-15, BS5304
Sicherheitskontakte- version ECS1	1 N/C zwangsgeführt 
version ECS2	2 N/C zwangsgeführt
Verwendungskategorie	AC 15
a.c. (Ue)	500V 250V 100V
(Ie)	1A 2A 5A
d.c.	250V 0.5A, 24V 2A
Dauerstrom (Ith)	10A
Zwangsöffnungsweg	>2 x2mm
Nennisolationsspannung	(Ui) 500V
max. Impuls-Prüfspannung	(Uimp) 2500V
Signalkontakt	1N/O (version ECS1)
Verschmutzungsgrad	3
Öffnen der Kontakte bei Rotation der Schalterwelle	Max 11°, Min 3° (justierbar)
min. Schliesskraft	8 cNm
Gehäuse	glasfaserverstärkter Polyester, selbstverlöschend. 
Betätigungsbügel	nichtrostender Stahl.
Schutzart	IP67
Kabeleinführungen	3 x M16 / 3 x Pg9
Betriebstemperatur	-25° to + 80°C
Befestigung	2 x M4
Einbaulage	beliebig
Reinigung	hochdruckfest
mech. Lebensdauer	>1 x 10 <sup>6</sup>

**Français**

Conforme aux standards	EN60947-5-1, PrEN1088 GS-ET-15, BS5304
Contacts de sécurité- version ECS1	1 N/C rupture positive 
version ECS2	2 N/C rupture positive
Catégorie d'utilisation	AC 15
a.c. (Ue)	500V 250V 100V
(Ie)	1A 2A 5A
d.c.	250V 0.5A, 24V 2A
Courant (Ith)	10A
Espace contacts de sécurité	>2 x2mm
Tension efficace	(Ui) 500V
Tension d'isolement	(Uimp) 2500V
Contacts auxiliaires	1N/O (version ECS1)
Degré de pollution	3
Rotation de l'arbre pour assurer le fonctionnement du contact	Max 11°, Min 3° (justable)
Force minimum rupture contact	2.5mm
Course maximum de la clé	8 cNm
Boîtier	Polyester renforcé fibre de verre autoextinguible 
Clé	IP67
Protection	3 x M16 / 3 x Pg 9
Entrée tube	-25° to + 80°C
Température	2 x M4
Fixation	Toutes positions
Montage	Peut-être nettoyé au jet haute pression
Nettoyage	
Durée de vie mécanique	>1 x 10 <sup>6</sup>

