



Application manual - Function table

ACTIVE Cube



General Information about the Documentation

This application manual complements the operating instructions and the „Quick Start Guide“ of the ACU frequency inverters (ACTIVE Cube series). This application manual contains all relevant information required for using the function table.

For better clarity, the documentation is structured according to the customer-specific requirements made on the frequency inverter.

Quick Start Guide

The Quick Start Guide describes the basic steps required for mechanical and electrical installation of the frequency inverter. The guided commissioning supports you in the selection of necessary parameters and the software configuration of the frequency inverter.

Operating Instructions

The Operating Instructions describe and document all functions of the frequency inverter. The parameters required for adapting the frequency inverter to specific applications as well as the wide range of additional functions are described in detail.

Application Manual

The application manual supplements the documentation for purposeful installation and commissioning of the frequency inverter. Information on various subjects connected with the use of the frequency inverter are described specific to the application.

Installation Instructions

Complementing the Brief Instructions and the Operating Instructions, the Installation Instructions provide information on how to install and use the additional/optional components.

If you need a copy of the documentation or additional information, contact your local representative of BONFIGLIOLI.

The following pictograms and signal words are used in the documentation:



Danger!

Danger refers to an immediate threat. Non-compliance with the precaution described may result in death, serious injury or material damage.



Warning!

Warning refers to a possible threat. Non-compliance with the warning may result in death, serious injury or material damage.



Caution!

Caution refers to an immediate hazard. Non-compliance may result in personal or material damage.

Attention!

Attention and the related text refer to a possible behavior or an undesired condition which can occur during operation.

Note

marks information which facilitates handling for you and supplements the corresponding part of the documentation.

1 General Safety Instructions and Information on Use



Warning! The specifications and instructions contained in the documentation must be complied with strictly during installation and commissioning. Only qualified staff who has read the documentation and, in particular, the safety instructions carefully is allowed to carry out installation or commissioning work or to operate the frequency inverters. The term „Qualified Staff“ refers to anybody who is familiar with the installation, assembly, commissioning and operation of the frequency inverter and has the proper qualification for the job.

The present documentation was prepared with great care and it was subjected to extensive and repeated reviews. For reasons of clarity, it was not possible to include all details of all types of the product in the documentation. Neither was it possible to consider all conceivable installation, operation or maintenance situations. If you require further information or if you meet with specific problems which are not dealt with in sufficient detail in the documentation, contact your national BONFIGLIOLI agent.

We would also like to point out that the contents of this documentation do not form part of any previous or existing agreement, assurance or legal relationship. Neither are they intended to supplement or replace such agreements, assurances or legal relationships. The manufacturer's obligations are exclusively specified in the relevant purchase contract. This contract also contains all and any warranty regulations which may apply to the relevant scope of supply. These contractual warranty provisions are neither extended nor limited by the specifications contained in this documentation.

The manufacturer reserves the right to correct or amend the specifications, product information and omissions in these operating instructions without notice. The manufacturer shall not be liable for any damage, injuries or costs which may be caused by the aforementioned reasons.

1.1 General Information



Warning! The DC-link circuit of the frequency inverter is charged during operation, i.e. there is always the risk of contact with high voltage. Frequency inverters are used for driving moving parts and they may become hot at the surface during operation.

Any unauthorized removal of the necessary covers, improper use, wrong installation or operation may result in serious injuries or material damage.

In order to avoid such injuries or damage, only qualified staff may carry out the transport, installation, setup or maintenance work required. The standards EN 50178, IEC 60364 (Cenelec HD 384 or DIN VDE 0100), IEC 60664-1 (Cenelec HD 625 or VDE 0110-1), BGV A2 (VBG 4) as well as the applicable national regulations must be complied with. The term „Qualified Staff“ refers to anybody who is familiar with the installation, assembly, commissioning and operation of the frequency inverter as well as the possible hazards and has the proper qualification for the job

1.2 Purpose of the Frequency Inverters



Warning! The frequency inverters are electrical drive components intended for installation in industrial plants or machines. Commissioning and start of operation is not allowed until it has been verified that the machine meets the requirements of the EC Machinery Directive 98/37/EEC and EN 60204. In accordance with the CE marking requirements, the frequency inverters also comply with the Low Voltage Directive 2006/95/EC as well as EN 50178/DIN VDE 0160 and EN 61800-2. The user shall be responsible for making sure that the requirements of the EMC Directive 89/336/EEC are met. Frequency inverters are only available at specialized dealers and are exclusively intended for professional use as per EN 61000-3-2.

The frequency inverters are also marked with the UL label according to UL508c, which proves that they also meet the requirements of the CSA Standard C22.2-No. 14-95.

The technical data, connection specifications and information on ambient conditions are indicated on the name plate and in the documentation and must be complied with in any case. Anyone involved in any kind of work at the device must have read the instructions carefully and understood them before starting the work.

Do not connect any capacitive loads.

1.3 Transport and Storage

The frequency inverters must be transported and stored in an appropriate way. During transport and storage the devices must remain in their original packaging. The units may only be stored in dry rooms which are protected against dust and moisture and are exposed to little temperature deviations only. Observe the climatic conditions according to EN 50178 and the marking on the packaging. The frequency inverters must not be stored for more than one year without connecting them to nominal voltage.

1.4 Handling and Installation



Warning! Damaged or destroyed components must not be put into operation because they may be a health hazard.

The frequency inverters are to be used in accordance with the documentation as well as the applicable directives and standards. They must be handled carefully and protected against mechanical stress. Do not bend any components or change the isolating distances. Do not touch electronic components or contacts. The devices are equipped with components which are sensitive to electrostatic energy and can easily be damaged if handled improperly. Any use of damaged or destroyed components shall be considered as a non-compliance with the applicable standards. Do not remove any warning signs from the device.

1.5 Electrical Connection



Warning! Before any assembly or connection work, discharge the frequency inverter. Verify that the frequency inverter is discharged. Do not touch the terminals because the capacitors may still be charged. Comply with the information given in the operating instructions and on the frequency inverter label.

When working at the frequency inverters comply with the applicable standards BGV A2 (VBG 4), VDE 0100 and other national directives. Comply with the electrical installation instructions given in the documentation as well as the relevant directives. The manufacturer of the industrial machine or plant is responsible for making sure that the limit values specified in the EMC product standard EN 61800-3 for electrical variable-speed drives are complied with. The documentation contains information on EMC-conforming installation. The cables connected to the frequency inverters may not be subjected to high-voltage insulation tests unless appropriate circuitry measures are taken before.

1.6 Information on Use



Warning! The frequency inverter may be connected to power supply every 60 s. This must be considered when operating a mains contactor in jog operation mode. For commissioning or after an emergency stop, a non-recurrent, direct restart is permissible. After a failure and restoration of the power supply, the motor may start unexpectedly if the AutoStart function is activated. If staff is endangered, a restart of the motor must be prevented by means of external circuitry. Before commissioning and the start of the operation, make sure to fix all covers and check the terminals. Check the additional monitoring and protective devices according to EN 60204 and applicable the safety directives (e.g. Working Machines Act, Accident Prevention Directives etc.). No connection work may be performed, while the system is in operation.

1.7 Maintenance and Service



Warning! Unauthorized opening and improper interventions can lead to personal injury or material damage. Repairs on the frequency inverters may only be carried out by the manufacturer or persons authorized by the manufacturer. Check protective equipment regularly.

TABLE OF CONTENTS

1	General Safety Instructions and Information on Use	2
1.1	General Information	2
1.2	Purpose of the Frequency Inverters	3
1.3	Transport and Storage	3
1.4	Handling and Installation	3
1.5	Electrical Connection.....	4
1.6	Information on Use	4
1.7	Maintenance and Service	4
2	Description of System.....	10
2.1	Chronological processing of function table.....	11
2.2	Starting the function table.....	11
2.3	Principle for digital functions.....	12
2.4	Principle for analog functions	14
2.5	Input buffer and output buffer for digital signals	16
2.6	Input buffer and output buffer for analog signals.....	17
3	Commissioning	20
3.1	Write index and read index.....	20
3.1.1	Write index and read index for FT-instructions.....	20
3.1.2	Write index and read index for the digital input buffer.....	22
3.1.3	Write index and read index for the analog input buffer and for FT-fixed values...23	
3.2	Parameterization in function table VTable	24
3.2.1	Digital functions	24
3.2.2	Analog functions	27
3.3	Run/Stop.....	27
3.3.1	Example Run/Stop	28
3.4	Comment field.....	29
3.5	Overview of functions	29
3.5.1	Overview table.....	29
3.6	Inputs and outputs	36
3.6.1	Inputs.....	36
3.6.2	Inputs of the digital functions.....	36
3.6.3	Inputs and outputs of the analog functions	37
3.7	Linking of inputs and outputs of FT-instructions.....	40
3.7.1	FT-inputs.....	40
3.7.2	FT-target outputs.....	42
3.7.3	Digital: Linking FT-input buffer with FT-inputs	42
3.7.3.1	Digital	42
3.7.3.2	Analog.....	44
3.7.4	Linking instructions to one another (FT-Input)	45
3.7.4.1	Digital	45
3.7.4.2	Analog.....	46
3.7.5	Linking output buffers (FT-target output)	47
3.7.5.1	Activating device functions via the output buffer	48
3.7.5.2	Controlling a digital output via the output buffer	49
3.7.5.3	Controlling an analog output via the output buffer.....	50

4	Explanation of the digital functions	52
4.1	Superior/Master	52
4.2	Parameters for chronological behavior and jump target	53
4.2.1	Chronological behavior	54
4.2.2	Jump target	54
4.2.3	Overview table	55
4.3	Boolean operations	56
4.3.1	[1] AND link	56
4.3.2	[2] OR link	57
4.3.3	[3] XOR 1-link	58
4.3.4	[4] XOR 1 3 link	59
4.4	Flip-Flop types	60
4.4.1	[10] RS-Flip-Flop, Superior	60
4.4.2	[110] RS-Flip-Flop, Master	62
4.4.3	[20] Toggle-Flip-Flop, Superior	63
4.4.4	[120] Toggle-Flip-Flop, Master	64
4.4.5	[30] D-Flip-Flop, Superior	65
4.4.6	[130] D-Flip-Flop, Master	66
4.5	Delay	67
4.5.1	[40,41,42] Delay (retriggerable), Superior	70
4.5.2	[140,141,142] Delay (retriggerable), Master	71
4.5.3	[50,51,52] Delay (not retriggerable), Superior	72
4.5.4	[150,151,152] Delay (not retriggerable), Master	73
4.6	Timer functions	75
4.6.1	[60,61,62] Monoflop (retriggerable), Superior	75
4.6.2	[160,161,162] Monoflop (retriggerable), Master	76
4.6.3	[70,71,72] Monoflop (not retriggerable), Superior	77
4.6.4	[170,171,172] Monoflop (not retriggerable), Master	78
4.6.5	[80,81,82] Clock generator, Superior	80
4.6.6	[180,181,182] Clock generator, Master	81
4.7	Digital Multiplexor	82
4.7.1	[90] Digital Multiplexor (data set number)	82
4.8	Switch	83
4.8.1	[91] Switch Data Set	83
4.9	Fault functions	84
4.9.1	[95] Trigger a fault	84
4.9.2	[96] Reset a fault	85
4.10	Debouncer	86
4.10.1	[97] Debouncer	86
4.11	No Operation	86
4.11.1	[99] NOP	86
4.12	Jump functions	87
4.12.1	[100] Jump function	87
4.12.2	[101] Jump function for loops	88
5	Description of the analog functions	89
5.1	Parameters for behavior	89
5.2	Comparators	89
5.2.1	[301,302] Comparator (Compare two Variables)	89
5.2.2	[303,304] Comparator (Compare constant to variable)	91
5.2.3	[308] Comparator Active Motion Block	92
5.2.4	[309] Position comparator (Long)	92
5.2.5	[310] Analogue Hysteresis	93
5.2.6	[311,312] Window-Comparator (Compares two Variables)	94
5.2.7	[313,314] Window-Comparator (Compares constant to variable)	95

5.2.8	[320] Min/Max	96
5.2.9	[321] Min/Max for Position Values (Long)	97
5.2.10	[322] Min/Max in time window	97
5.2.11	[323] Min/Max for Positions (Long) in time window	98
5.3	Mathematical function	99
5.3.1	Addition and subtraction	99
5.3.1.1	[330] Add. $A1 = -A2 = E1 + E2 - E3 + P1 - P2$	99
5.3.1.2	[331] Add. long $A1 = E1 + E2 - E3 + P$	100
5.3.2	Multiplication	101
5.3.2.1	[332] Mult. ($A1 = E1 * E2 * P1$)	101
5.3.2.2	[333] Mult. w. result long ($A = E1 * E2 * P1$)	101
5.3.2.3	[334] Mult. w. fraction ($A1 = E1 * P1 / P2$)	102
5.3.2.4	[335] Mult. long * Percent	102
5.3.3	Division	103
5.3.3.1	[336] Div. $A1 = (E1 / E2 / E3)$	103
5.3.3.2	[337] Div. $A1 = (E1 / P1)$	103
5.3.3.3	[338] Div. $A1 = (P1 / E1)$, reciprocal value	104
5.3.4	[339] Mult. & Div ($A1 = (E1 * E2) / E3$)	104
5.3.5	[340] Average function	105
5.3.6	[341] Value of two orthogonal components	105
5.3.7	[342] Value of three orthogonal components	106
5.3.8	[350] Integrator ($A1 = \text{Int}(E1 * dt)$)	106
5.3.9	[351] Differentiator (D-Element) ($A1 = dE1 / dt$)	107
5.3.10	[360] Absolute Value	108
5.3.11	[361] X^2	108
5.3.12	[362] X^3	109
5.3.13	[363] \sqrt{X}	109
5.4	Controller	110
5.4.1	[370] P-Controller	110
5.4.2	[371] PI-Controller (T_n in milliseconds)	110
5.4.3	[372] PI-Controller (T_n in seconds)	111
5.4.4	[373] PD(T_1)-Controller	111
5.4.5	[374] PID(T_1)-Controller (T_n in milliseconds)	112
5.4.6	[375] PID(T_1)-Controller (T_n in seconds)	113
5.5	Filter	114
5.5.1	[380] PT1-element	114
5.5.2	[381] Time average	115
5.5.3	[382] Ramp limiter	116
5.5.4	[383] Spike-Filter (Middle of three)	117
5.6	Analog switches	118
5.6.1	[390] Analogue Multiplexer (data set no.)	118
5.6.2	[391] Analog Switch	119
5.6.3	[392] MUX for position values (data set no.), Multiplexer	119
5.6.4	[393] Switch for position values	120
5.7	Parameter access	120
5.7.1	Write parameter	120
5.7.1.1	[401] Write frequency parameter	121
5.7.1.2	[402] Write current parameter	121
5.7.1.3	[403] Write voltage p. (eff.)	122
5.7.1.4	[404] Write voltage p. (peak)	122
5.7.1.5	[405] Write Perc. Parameter	123
5.7.1.6	[406] Write Position Parameter	123
5.7.1.7	[407] Write Long Parameter	124
5.7.1.8	[408] Write Word Parameter	124
5.7.2	Read parameter	124
5.7.2.1	[421] Read frequency parameter	125
5.7.2.2	[422] Read current parameter	125
5.7.2.3	[423] Read voltage p. (eff.)	125
5.7.2.4	[424] Read voltage p. (peak)	126

5.7.2.5	[425] Read Perc. Parameter	126
5.7.2.6	[426] Read Position Parameter	126
5.7.2.7	[427] Read Long Parameter	126
5.7.2.8	[428] Read Word Parameter	127
5.8	 Limiter	127
5.8.1	[440] Limiter (Const.)	127
5.8.2	[441] Limiter (Variable)	128
5.9	 Counter	128
5.9.1	[450] Up/Down Counter with analogue output	128
5.9.2	[451] Clock with analogue output	130
5.10	 Positioning functions	131
5.10.1	[501] Start Motion Block (Single mode)	131
5.10.2	[502] Start Motion Block (Automatic mode)	132
5.10.3	[503] Motion Block: Interrupt	132
5.10.4	[504] Motion Block: Continue	133
5.10.5	[505] Motion Block: Resume	133
5.10.6	[506] Start Homing	134
5.10.7	[507] Check state	135
5.11	 Bit-Functions for analog input values	135
5.11.1	[200] Bit by Bit NOT	136
5.11.2	[201] Bit by Bit AND/NAND	136
5.11.3	[202] Bit by Bit OR/NOR	137
5.11.4	[203] Bit by Bit XOR/XNOR	138
5.11.5	[210] Bit Shift right	139
5.11.6	[211] Bit arithm. Shift Right	140
5.11.7	[212] Bit Shift left	140
5.11.8	[213] Bit Roll right	141
5.11.9	[220] Output 1 Bit	141
5.11.10	[221] Merge 4 Bits to 1 Word	142
5.11.11	[222] Add 2 Bits to 1 Word	143
6	 Examples	144
6.1	 Example 1: Link two digital inputs	144
6.2	 Example 2: Link of several FT-instructions	144
6.3	 Example 3: Parameterization of logic diagram	147
7	 Actual values and output signals	148
7.1	 Actual values of digital functions	148
7.2	 Actual values of analog functions	149
7.3	 Digital output signals of the function table	150
7.4	 Analog output signals of the function table	150
7.5	 Logic signal sources of the function table	151
8	 State machine operation	152
8.1	 Control example	152
9	 Parameter List	159
9.1	 Actual Value Menu (VAL)	159
9.2	 Parameter Menu (PARA)	159

10 Annex	161
10.1 Mask: Functions diagram	161
10.2 Mask: Functions settings	162
Index	163

2 Description of System

With the Function Table (FT), external digital signals and internal logic signals of the frequency inverter can be linked to one another. Analog signals can be affected by analog and mathematical functions and output the results. Function table functions are also referred to as FT-instructions.

The results of the FT-instructions can be used by other device functions (e.g. comparator) or output via digital outputs. The results can also be used as input values by other FT instructions. For parameterization of the function table using the VTable application, the commissioning and diagnosis software VPlus, version 4 or higher is required. The FT instructions can be parameterized as tables via VTable. Each FT-instruction is represented in VTable by a column.

Within the table, the functions are processed column by column (index by index) down to parameter setting "0 - Off (last table entry)" for *FT-instruction 1343*. Then, the processing is started again with the first column of the table (the first index).

Function table:

- Access to the FT instructions is via a table (VTable).
- Up to 32 FT-instructions are available via the index parameters of the table.
- Each column of the table describes an instruction.
- The processing order corresponds to the order in the table (index 1 to 32).
- Via a **digital** input buffer, digital signal sources (e.g. run signal, error signal) and digital inputs (e.g. S2IND) can be assigned to the FT-instruction inputs. The input buffer enables 16 entries and contains, by default, typical signal sources/digital inputs.
- Via an **analog** input buffer, analog signal sources (e.g. frequencies) can be assigned to the FT-instruction inputs. The input buffer enables 4 entries.
- Via an output buffer, the output values of the FT-instructions can be made generally (globally) available and used by other functions or output via digital outputs. Up to 16 signal sources can be used as digital output buffer or 24 signal sources as analog output buffer for this purpose.
- All output values of the FT instructions have defined values when the frequency inverter is initialized. They are FALSE (digital instructions) or have the value 0 (analog instructions) for all FT-instruction outputs and all output buffer values. After initialization, the inverted FT-instruction outputs are TRUE.
- The outputs of FT-instructions can be assigned to other device functions (e.g. Start Clockwise, Switch Data Set etc.) or digital or analog outputs (e.g. S1OUT).
- Processing of the function table can be activated and deactivated by a parameter (Run / Stop).

Each column is described by a certain number of parameters:

- FT-instruction: Selection of FT-instruction (digital: AND, OR, etc; analog: Addition, Absolute value, etc).
- FT-inputs: FT-instructions have four inputs.
- FT-parameter 1 and FT-parameter 2: These parameters enable, depending on the selected FT-instruction, setting of delay times, factors or jumps between functions.
- FT-target outputs: The value of a function output can be moved to the output buffer and is then generally (globally) available to other device functions.

Each digital instruction has two outputs A1 and A2 (A2 = A1 inverted for digital instructions). The output values of FT-instructions can also be used as input values in other FT-instructions.

2.1 Chronological processing of function table

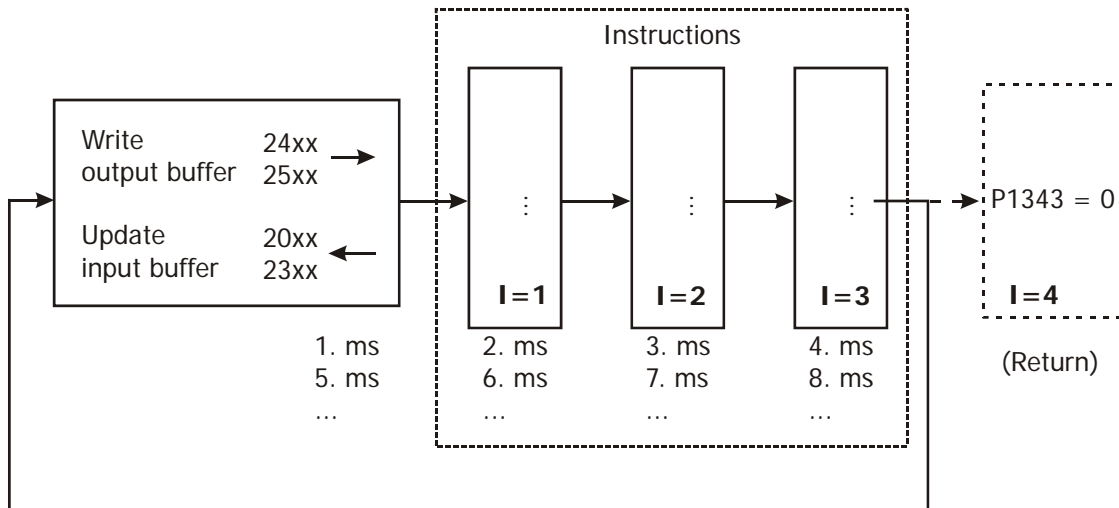

The function table is processed cyclically. In the first step, the output buffer is written to the global variables

- 24xx for digital and analog signals
- 25xx for analog signals

After that the input buffer is updated in sources

- 20xx for digital signals
- 23xx for analog signals

Then the FT-instructions are processed, starting with Index 1.

A cycle is complete when a subsequent function is deactivated (*FT-instruction 1343* = "0 - Off (Last Table Item)") or the maximum number of FT-instructions was processed. Then the processing cycle is started again (write output buffer, update input buffer, index 1, index 2, ...).

The processing time of each instruction is 1 ms.

Additionally, 1 ms is required for writing the output signals 24xx/25xx and reading of input signals 20xx/23xx.

As a result, the cycle time is the total of instructions + 1 in milliseconds.

2.2 Starting the function table

By default (factory setting), the function table is stopped and must be started by parameter *FT-RunMode 1399*. In stop mode, no instructions are processed and there is no writing of the output buffer.

Note:

Instructions can only be edited in stop mode.

2.3 Principle for digital functions

The function table processing principle for digital functions is shown in the following diagram. The input buffer comprises 16 indices which can be assigned to global sources. By default, the digital input signals of the basic device and various other, frequently used signals are entered in the input buffer. The values in the input buffer are available to the instructions as sources (range 20xx).

The instructions are linked to 4 input values. Depending on the type of instructions, two parameters are used for adjusting special instruction functions. The outputs of the instructions can be used as inputs of other functions (non-negated outputs 21xx and negated outputs 22xx).

In addition, the outputs can be used as sources for global variables.

The instructions are processed one after the other, starting with instruction 1. When the processing cycle jumps back to start, the output buffer is written and the input buffer is updated.

Jump functions enable branching off to certain instructions. The instruction parameters of the jump function additionally enable selective writing of the output buffer and updating of the input buffer.

Digital signal sources for the inputs of digital FT-instructions

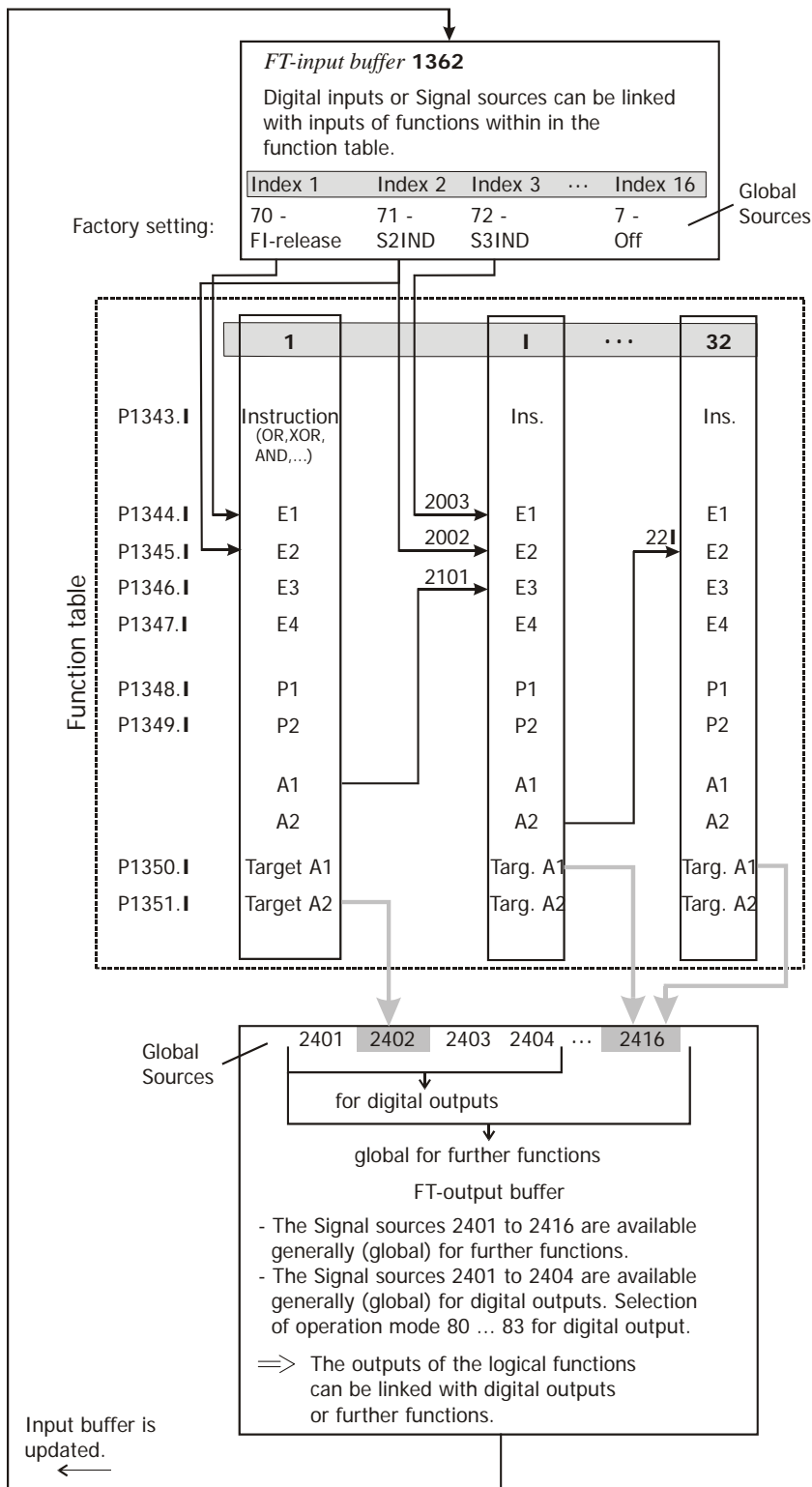

Abbreviations used:

- FT: Function table
- I: Index of function table (1 ... 32)
- P.: Parameter
- E: Input
- A1, A2: Outputs for links within the function table (internal)
- Target A1, Target A2: Outputs for global links. P1350 and P1351 are needed for global links only.

At first, the output buffer is updated. Then, the input buffer is updated. The values of the global sources are taken over in the output buffer. Then, the global input values in the input buffer are updated.

2.4 Principle for analog functions

The function table processing principle for analog functions is shown in the following diagram. The analog input buffer comprises parameters with four indices each which can be assigned to global sources. The values in the input buffer are available to the FT-instructions inputs as sources (range 23xx – “Input Buffer” and 26xx – “Fixed Values”).

The instructions are linked to four input values (E1 ... E4). Depending on the type of instructions, two parameters (P1 and P2) are used for adjusting special instruction functions. The outputs (A1 and A2) of the instructions can be used as inputs of other functions (non-negated outputs 21xx and negated outputs 22xx).

In addition, the outputs (Target A1 and Target A2) can be used as sources for global variables. The instructions are processed one after the other, starting with instruction 1. When the processing cycle jumps back to start, the output buffer is written and the input buffer is updated.

Jump functions enable branching off to certain instructions. The instruction parameters of the jump function additionally enable selective writing of the output buffer and updating of the input buffer.

Analog function can process the following values:

- frequency
- current
- percent
- position
- ramp of the positioning

Analog signal sources and fixed values for the inputs of analog FT-instructions and output signals of the FT-instructions

VTable

analog	Index 0	Index 1	Index 2	Index 3	Index 4
Assign analog global signal sources to the parameters of the analog FT-input buffer.					
P1379.I					
P1380.I					
P1381.I					
P1382.I					
P1383.I					
Enter values for fixed value parameters.					
P1388.I					
P1389.I					
P1390.I					
P1391.I					
P1392.I					
P1393.I					
P1394.I					
P1395.I					

Selection ▲
▼

Value entry

Value entry

Analog global signal sources

Input signal source number

Fixed values

VTable

Function table	Index 1	I	...	32
P1343.I	Instruction	2101	Ins.	221
P1344.I	2301		E1	E1
P1345.I	2303		E2	E2
P1346.I	E3		E3	E3
P1347.I	E4		E4	E4
P1348.I	P1		P1	P1
P1349.I	P2		P2	P2
	A1		A1	A1
	A2		A2	A2
P1350.I	Target A1		Targ. A1	Targ. A1
P1351.I	Target A2		Targ. A2	Targ. A2

The signal sources 25xx are available generally (global) for further functions:

FT-Output Frequency 2501 ... 2504	FT-Output Current 2511 ... 2514	FT-Output Percentage 2521 ... 2524
FT-Output Voltage 2531 ... 2534	FT-Output General value 2551 ... 2554	FT-Marker 2561 ... 2564

This signal sources are available for analog outputs of the device:

- 61 - Abs. Val. FT-Output Percentage 1
- 62 - Abs. Val. FT-Output Percentage 2
- 161 - FT-Output Percentage 1
- 162 - FT-Output Percentage 2

VPlus

Parameter	Data set 1
	Selection ▲ ▼

The outputs of the analog functions can be linked to further functions or with analog outputs of the device.

Abbreviations used:

FT:	Function table
I:	Index of function table (1 ... 32)
P.:	Parameter
E:	Input
A1, A2:	Outputs for links within the function table (internal)
Target A1, Target A2:	Outputs for global links.

2.5 Input buffer and output buffer for digital signals

In the frequency inverter, the digital signals can be used in various ways. The number of possible function table signals, however, is very high. As a result, it would be confusing if all signals were available globally.

For this reason, the number of globally available signals is limited via an input buffer and an output buffer. In addition, the input buffer is updated and the output buffer is written at a defined point of time. In this way it is ensured that the processing within a cycle is performed based on the same input data and inconsistent statuses are avoided.

Input buffer:

By default, the input buffer is filled with various digital signals. BONFIGLIOLI VECTRON recommends keeping the standard settings if possible. This makes diagnosis and commissioning easier.

<i>FT-input buffer 1362</i>			
Index	Factory setting	Index	Factory setting
1	70 - Inverter Release	9	7 - Off
2	71 - S2IND -	10	7 - Off
3	72 - S3IND	11	160 - Standby Message
4	73 - S4IND	12	161 - Run Message
5	74 - S5IND	13	162 - Error Signal
6	75 - S6IND	14	163 - Reference Frequency Reached
7	76 - MF11D	15	7 - Off
8	7 - Off	16	7 - Off

Output buffer:

By default, the output buffer is linked without any signals. In order to write a digital output, a FT-target output must be assigned first (e.g. operation mode "2402 - FT-Output Buffer 2"). Then, the signal must be assigned to the device function. Operation modes 2401 to 2404 are available to digital outputs. Operation modes 2401 to 2416 are available to other functions, e.g. comparators.

At the start of a cycle, the input buffer is read and kept in the function table memory until the next return jump. Then, the instructions are processed. The output buffer is written at the end of the cycle and is available in the global sources after that.

By selective use of the jump function, the input buffer and output buffer can be set and written either separately or jointly. This enables setting of the digital output signals during a cycle.

Note:

The input and output buffers are set and written during **the return jump**. This is done in one processing cycle. The output buffer is written **first, after that** the input buffer is set.

2.6 Input buffer and output buffer for analog signals

In the frequency inverter, the analog signals can be used in various ways. The number of possible signals, however, is very high. As a result, it would be confusing if all signals were available globally.

For this reason, the number of globally available signals is limited via an input buffer and an output buffer. In addition, the input buffer is updated and the output buffer is written at a defined point of time. In this way it is ensured that the processing within a cycle is performed based on the same input data and inconsistent statuses are avoided.

- Consistent values, values sampled at the same time are processed
- Clarity because of limited number of signals
- Conversion to percentage, the table functions process percentage values

Input buffer:

Signal sources of the inverter can be selected for the parameters of the input buffer. Physical values according to the parameter names or percentage values are available as signal sources. Then the selected signal sources of the frequency inverter can be assigned to the inputs of the FT-instructions via the signal sources 23xx (*FT-input 1* **1344** or *FT-input 2* **1345** = "23xx - ...").

Parameter		Settings	
No.	Description	Selection	Fact. sett.
1379	FT-input buffer frequency	Signal source frequency value	9 - Zero
1380	FT-input buffer current	Signal source current value	9 - Zero
1381	FT-input buffer percentage	Signal source percentage value	9 - Zero
1382	FT-input buffer voltage	Signal source voltage value	9 - Zero

Assign signal sources to inputs. Example: Assign frequency value "Ramp output" to input 2 of an instruction.

Input buffer analog	Index 0	Index 1	Index 2	Index 3	Index 4
<i>FT-input buffer frequency</i> 1379				0 - Ramp output	

Function Table	Index 1
<i>FT-input 2</i> 1345	2303 - Frequency from P.1379 index 3

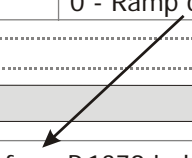

For parameter *FT-input buffer gen. source* **1383** the number of a generally available signal source of the frequency inverter can be entered. Then the entered signal source of the frequency inverter can be assigned to the inputs of the FT-instructions via the signal sources 235x (*FT-input 1* **1344** or *FT-input 2* **1345** = "235x – General source from P.1383 index ...").

Via the parameters *numerator gen. source inp.* **1383** **1384** and *denomin. gen. source inp.* **1383** **1385** the value of *FT-input buffer gen. source* **1383** can be scaled:

235x General source from P. 1383 index ... =

$$FT - input\ buffer\ gen.\ source\ 1383 * \frac{numerator\ gen.\ source\ inp.\ 1383\ 1384}{denomin.\ gen.\ source\ inp.\ 1383\ 1385}$$

Parameter		Settings		
No.	Description	Min.	Max.	Fact. sett.
1383	FT-input buffer gen. source	0	2147483647	9
1384	numerator gen. source inp. 1383	-327.68%	327.67%	100.00%
1385	denomin. gen. source inp. 1383	0.01%	327.67%	100.00%

Scaling of *FT-input buffer gen. source 1383*:

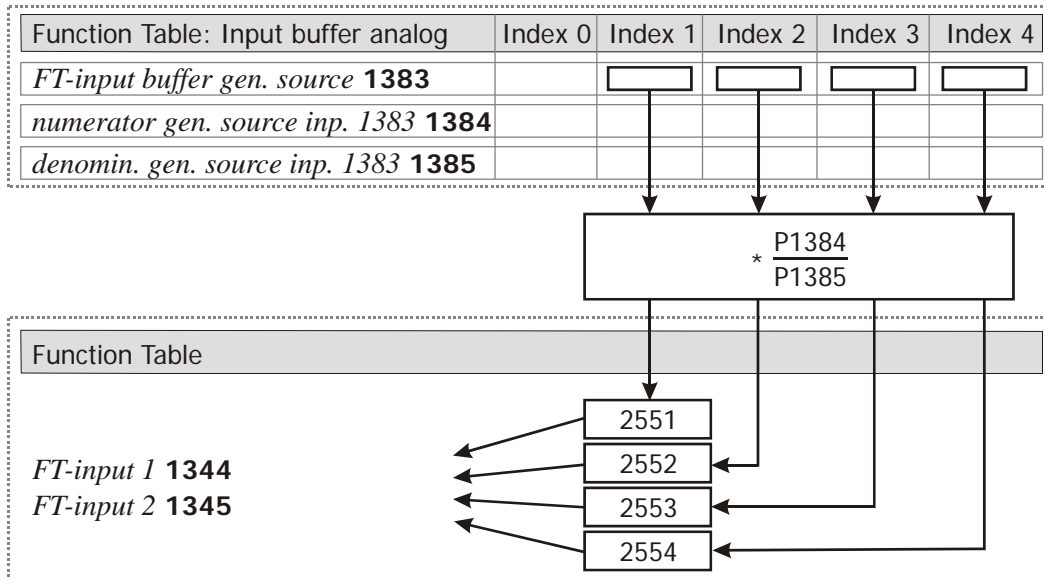

Via the parameters *numerator gen. source outp. 2551 1386* and *denomin. gen. source outp. 2551 1387* the value of the FT-output signal "2551 - FT-Output General value 1" can be scaled.

Parameter		Settings		
No.	Description	Min.	Max.	Fact. sett.
1386	numerator gen. source outp. 2551	-327.68%	327.67%	100.00%
1387	denomin. gen. source outp. 2551	0.01%	327.67%	100.00%

Scaling of FT-output signal 2551

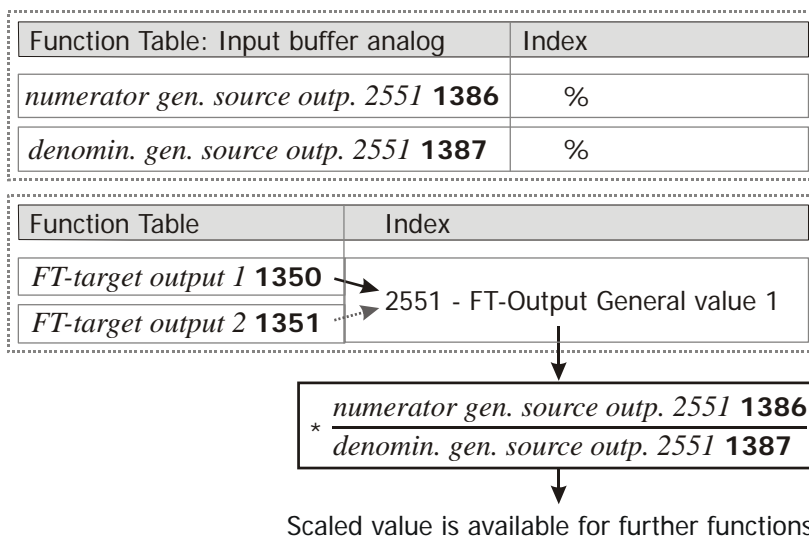

Physical values can be entered for the fixed value parameters of the input buffer. Then the fixed values can be assigned to the inputs of the FT-instructions via the signal sources 26xx (*FT-input 1 1344* or *FT-input 2 1345* = "26xx – Fixed value ... from P. ... index ...").

Parameter		Settings		
No.	Description	Min.	Max.	Fact. sett.
1388	FT-fixed value frequency	-999.99 Hz	999.99 Hz	50.00 Hz
1389	FT-fixed value current	-8.0 A	8.0 A	4.0 A
1390	FT-fixed value percentage	-327.67%	327.67%	100.00%
1391	FT-fixed value voltage	-1000.0 V	1000.0 V	565.7 V
1392	FT-fixed value position	-2147483647 u	2147483647 u	65536 u
1393	FT-fixed value speed Pos.	-2147483647 u/s	2147483647 u/s	163840 u/s
1394	FT-fixed value ramp Pos.	1 u/s ²	2147483647 u/s ²	327680 u/s ²

Assign fixed values to inputs. Example: Assign a current fixed value to input 1 of an instruction.

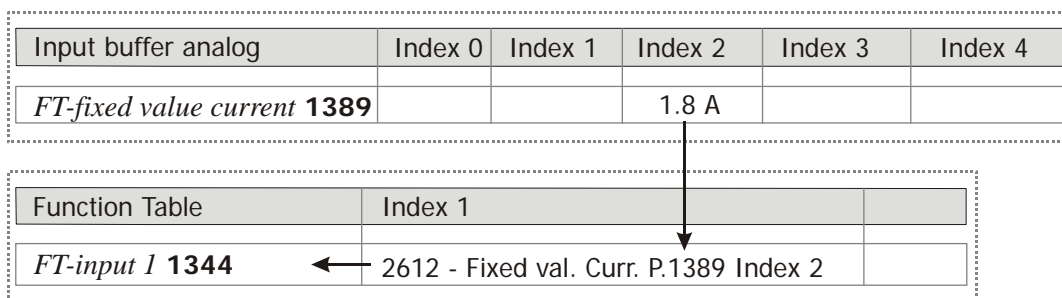

Values without physical unit can be entered for the parameter *FT-fixed value general 1395*. Then the fixed value can be assigned to the inputs of the FT-instructions via the signal sources 265x (*FT-input 1 1344* or *FT-input 2 1345* = "265x – Fixed val. general P.1395 I. ..."). Via the parameters *numerator fixed value gen. 1395 1396* and *denomin. fixed value gen. 1395 1397* the value of *FT-fixed value general 1395* can be scaled:

Parameter		Settings		
No.	Description	Min.	Max.	Fact. sett.
1395	FT-fixed value general	-32767	32767	0
1396	numerator fixed value gen. 1395	-327.67%	327.67%	100.00%
1397	denomin. fixed value gen. 1395	0.01%	327.67%	100.00%

Note:

The name of analog sources and the last digit of the analog source numbers for FT-inputs correspond to the table index of the analog input latch. For example: The input of an instruction should be linked to the analog input MF11A of the device. The analog input MF11A is selected in index 3 of the input latch table. Signal source "2323 – Percentage from P.1381 index 3" must be selected for the input of the instruction.

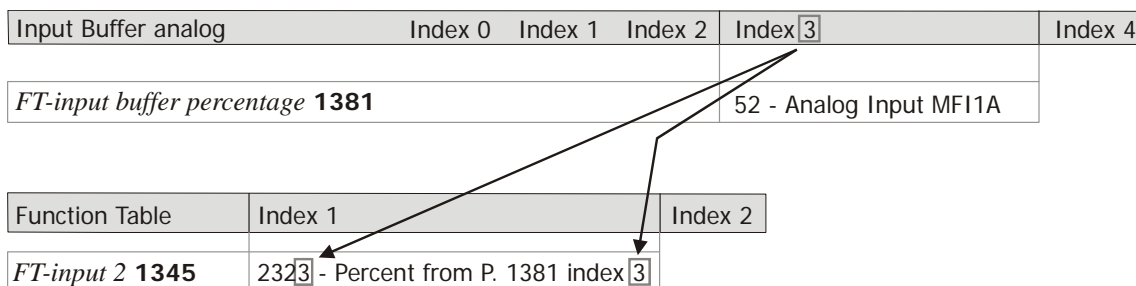

Output buffer:

By default, the output buffer is linked without any signals. In order to write an analog output, a FT-target output must be assigned first (e.g. operation mode "2521 - FT-Output Buffer Percent 1"). Then, the signal must be assigned to the device function.

The following operation modes are available to analog outputs of the device:

- 61 – "Abs. Val. FT-Output Percentage 1"
- 62 – "Abs. Val. FT-Output Percentage 2"
- 161 – "FT-Output Percentage 1"
- 162 – "FT-Output Percentage 2"

At the start of a cycle, the input buffer is read and kept in the function table memory until the next return jump. Then, the instructions are processed. The output buffer is written at the end of the cycle and is available in the global sources after that.

By selective use of the jump function, the input buffer and output buffer can be set and written either separately or jointly. This enables setting of the output signals during a cycle.

The output values of instructions can be stored in the following signal sources of the output buffer:

Signal sources for <i>FT-target output 1 1350</i> , <i>FT-target output 2 1351</i>	
2501 ... 2504	FT-Output Frequency 1 ... 4
2511 ... 2514	FT-Output Current 1 ... 4
2521 ... 2524	FT-Output Percentage 1 ... 4
2531 ... 2534	FT-Output Voltage 1 ... 4
2551 ... 2554	FT-Output General value 1 ... 4
2561 ... 2564	FT-Marker 1 ... 4

3 Commissioning

The function table is deposited internally via index-based parameters. In this way, the parameter number is the same for each instruction and the presentation is very straightforward. Via the index, the individual instructions are addressed and thus identified clearly. BONFIGLIOLI VECTRON recommends using the program VTable of the commissioning and diagnosis software VPlus for commissioning and editing the instructions. VTable enables comfortable and straightforward parameterization of the whole function table.

Note:

Die Parametrierung mit Hilfe der Functionentabelle VTable erfordert die Inbetriebnahme- und Diagnosesoftware VPlus der Version 4 oder höher.

Note:

In the KP500 control unit, parameter numbers > 999 are represented in hexadecimal form (999, A00 ... B54 ... C66 ...) concerning the leading numeral.

3.1 Write index and read index

3.1.1 Write index and read index for FT-instructions

Via the write and read indices, the index of the instruction the parameters of which are to be read or written is specified. VTable uses the parameters automatically for writing and reading. The write and read parameters are required for parameterization via keypad or for parameterization via a bus system (e.g. PROFIBUS).

Write index and read index for parameterization and reading of FT-instructions via software VPlus

The FT-instructions can be parameterized in the user interface VPlus or in the function table VTable. In the user interface VPlus, an index of the function table can be created via parameter *FT-write index (FT-table item) 1341*. The chosen index corresponds to a column in the function table. The settings of parameters **1343** to **1351** are taken over in the selected index of the function table. Via parameter *FT-read index (FT-table item) 1342*, the values of a selected index can be read from the function table.

Parameter		Setting		
No.	Description	Min.	Max.	Fact. sett.
1341	FT-write index (FT-table item)	0	65	1
1342	FT-read index (FT-table item)	0	65	1

Settings for fixed parameterization (non-volatile):

0: all instructions in EEPROM

1 ... 32: individual instructions in EEPROM

Settings only required for parameterization via communication interface (volatile):

33: all instructions in RAM

34 ... 65: individual instructions in RAM

Note:

The settings "0" and "33" for *FT-write index (FT-table item) 1341* change all functions in EEPROM and RAM.

In the case of non-volatile storage (0...32), the changed values are still available when power supply is switched on again.

In the case of volatile storage (33...65), the data is only stored in RAM. If the unit is switched off, this data is lost and the data required are loaded from EEPROM.

Definition:

Instruction RAM = instruction EEPROM + 33

Write index and Read index for FT-instructions of the function table

VPlus		VTable		
Parameter	D-Satz 0	Funktionentabelle	Index 1	Index 2
<i>FT-Write index (FT-table item) 1341</i>	2	<i>FT-instruction 1343</i>	2 - OR	1 - AND
<i>FT-Read index (FT-table item) 1342</i>	2	<i>FT-input 1 1344</i>
<i>FT-instruction 1343</i>	AND	<i>FT-input 2 1345</i>
<i>FT-input 1 1344</i>	...	<i>FT-input 3 1346</i>
<i>FT-input 2 1345</i>	...	<i>FT-input 4 1347</i>
<i>FT-input 3 1346</i>	...	<i>FT-Parameter 1 1348</i>
<i>FT-input 4 1347</i>	...	<i>FT-Parameter 2 1349</i>
<i>FT-Parameter 1 1348</i>	...	<i>FT-target output 1 1350</i>
<i>FT-Parameter 2 1349</i>	...	<i>FT-target output 2 1351</i>
<i>FT-target output 1 1350</i>	...			
<i>FT-target output 2 1351</i>	...			
<i>FT-actual values output buffer 1357</i>	...			
<i>FT-actual values input buffer 1358</i>	...			

3.1.2 Write index and read index for the digital input buffer

Via the write and read indices, the index of "Function table: input buffer" to be read or written is specified.

Write index and read index for parameterization and reading of input buffer via software VPlus

The "Function Table: Input buffer" can be parameterized in the user interface VPlus or in the function table VTable. In the user interface VPlus, an index of the function table can be set via parameter *FT-write index (FT-input buffer)* **1360**. The selected index corresponds to a table column in "Function Table: Input buffer" and thus to an index of parameter *FT-input buffer* **1362**. The setting (selection of signal source or digital input) of parameter *FT-input buffer* **1362** is taken over in the selected index of "Function Table: Input buffer". Via parameter *FT-read index (FT-input buffer)* **1361**, the values of a selected index can be read from "Function Table: Input buffer".

Parameter		Setting		
No.	Description	Min.	Max.	Fact. sett.
1360	FT-write index (FT-input buffer)	0	33	1
1361	FT-read index (FT-input buffer)	0	33	1

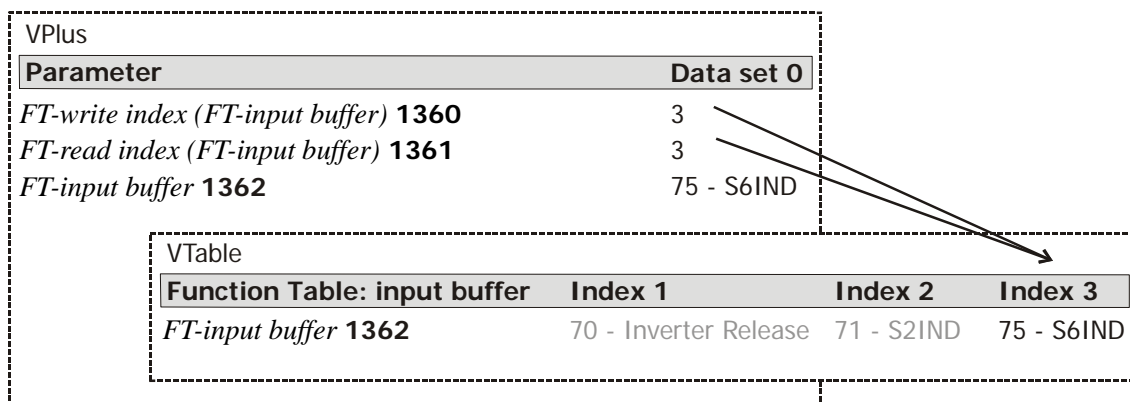

Settings for fixed parameterization (non-volatile):
 0: all input buffers in EEPROM
 1 ... 16: single input buffer in EEPROM

Settings only required for parameterization via communication interface (volatile):
 17: all input buffers in RAM
 18 ... 33: single input buffer in RAM

Note:

The settings "0" and "16" for *FT-input buffer* **1362** change all functions in EEPROM and RAM.

In the case of non-volatile storage (0...32), the changed values are still available when power supply is switched on again.

In the case of volatile storage (33...65), the data is only stored in RAM. If the unit is switched off, this data is lost and the data required are loaded from EEPROM.

Definition:

Input buffer RAM = input buffer EEPROM + 17

3.1.3 Write index and read index for the analog input buffer and for FT-fixed values

Via Write index and Read index the index of the "Input buffer analog"-table for writing or reading parameters is determined. VTable automatically uses the parameters for writing and reading. The write- and read-parameters are applicable to parameterize via keypad or bus system (for example PROFIBUS).

Write index and Read index for parameterization and reading out the "Input buffer analog"-table via software VPlus

The "Input buffer analog"-table can be parameterized in the user interface VPlus or in the Function table. In the user interface VPlus an index of the "Input buffer analog"-table can be set via the parameter *FT-write index (FT-input analog) 1377*. The set index corresponds to an index of the "Input buffer analog"-table. The settings of the parameters 1379 to 1397 are taken over in the selected index of the "Input buffer analog"-table. Via parameter *FT-read index (FT-input analog) 1378* values of a set index can be read out from the "Input buffer analog"-table.

Parameter		Setting		
No.	Description	Min.	Max.	Fact. sett.
1377	FT-write index (FT-input analog)	0	9	1
1378	FT-read index (FT-input analog)	0	9	1

Write index and Read index for "Input latch analog"-table

VPlus		Data set 0	
Parameter			
<i>FT-write index (FT-input analog) 1377</i>	2		
<i>FT-read index (FT-input analog) 1378</i>	2		
<i>FT-input buffer frequency 1379</i>	62 - Reference Frequency Channel		
<i>FT-input buffer current 1380</i>	126 - Active Current		
.	...		
.	...		
.	...		

VTable		
Input buffer analog	Index 1	Index 2
<i>FT-input buffer frequency 1379</i>	9 - Zero	62 - Reference Frequency Channel
<i>FT-input buffer current 1380</i>	9 - Zero	126 - Active Current
.
.
.

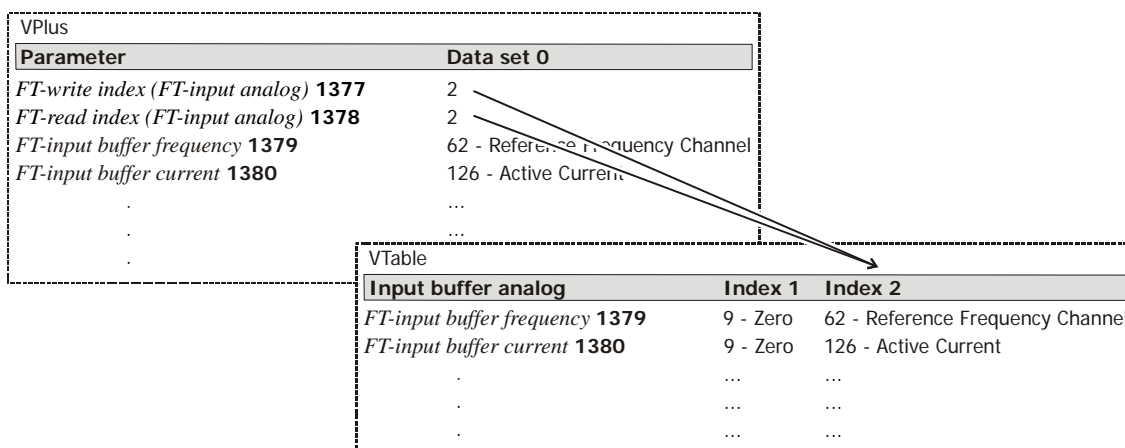

3.2 Parameterization in function table VTable

3.2.1 Digital functions



Click on button in VPlus to open the function table VTable.

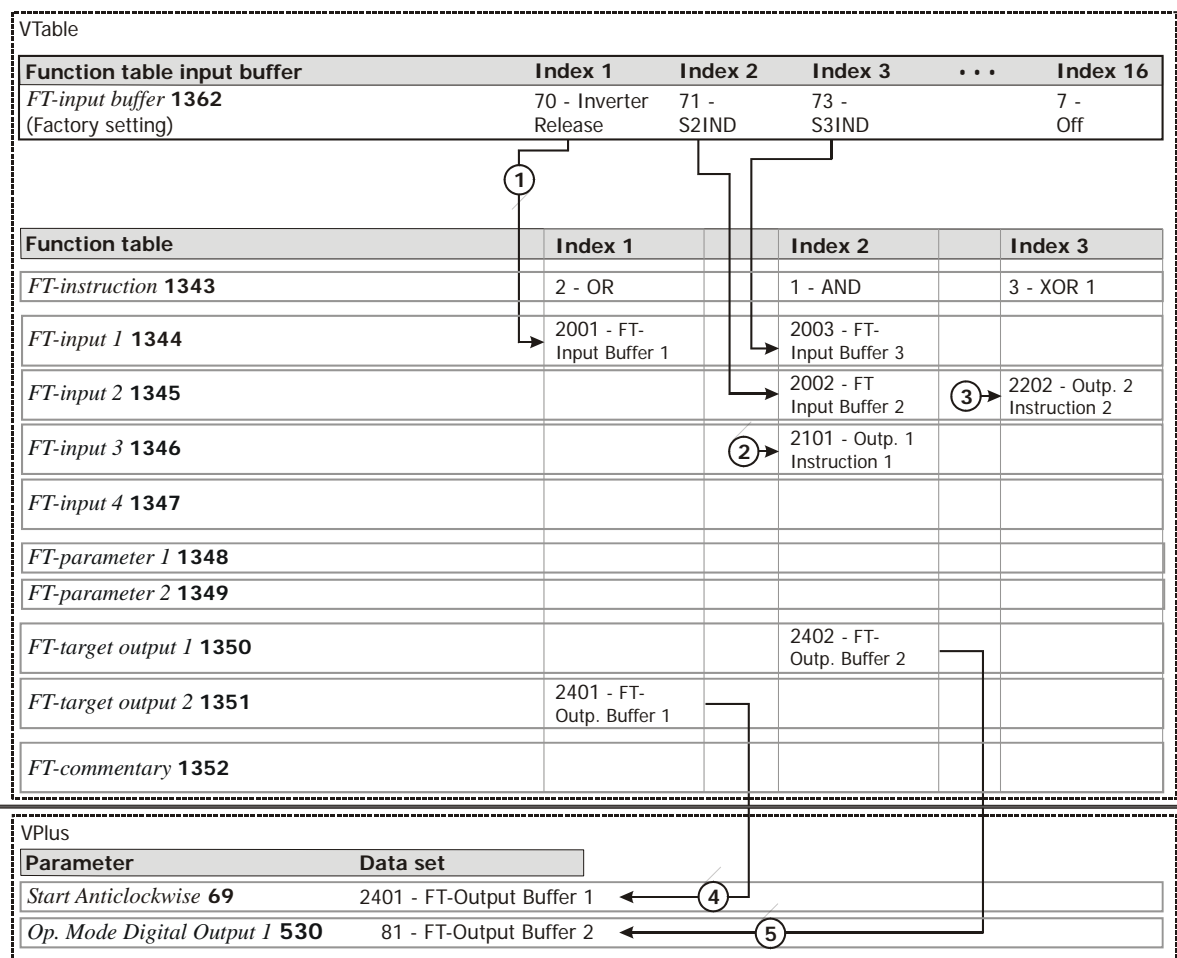

- ① Link the input of a FT-instruction to a digital input or signal source. Refer to chapter 3.7.3.1.
- ② Link the input of a FT-instruction to the output of a FT-instruction. Refer to chapter 3.7.4.1.
- ③ Link the input of a FT-instruction to the inverted output of a FT-instruction. Refer to chapter 3.7.4.1.
- ④ Link the output of a FT-instruction to a function outside of the function table. Link to signal sources "FT-Buffer" required. Refer to chapter 3.7.5.1.
- ⑤ Output the output value of a FT-instruction via a digital output. Link to signal sources "FT-Buffer" required. Refer to chapter 3.7.5.2.

FT: Function table

Function table input buffer: Digital inputs and signal sources (which are no output signals of FT-instructions) are made available to the inputs of FT-instructions. In Index 1 to 16, the different digital inputs and signal sources required for the inputs of the FT-instructions can be selected.

Example: Link of FT-input 1 of FT-instruction 2 (Index 2) to digital input S3IND:

- In Index 3 of function table input buffer:
Parameters *FT-input buffer 1362* = "72 - S3IND",
- In Index 2 of function table:
FT-input 1 1344 = "2003 - FT-Input Buffer 3".

A digital input or signal source of the input buffer can be linked to several FT-instruction inputs.

Parameters "**FT-target output**" for selection of signal source "**FT-Output Buffer**": Signal sources 2401 to 2416 can be used for making the output value of a FT-instructions generally (globally) available. This is required if

- the output of a FT-instruction is to be linked to another device function (no FT-instruction), e.g. to "Start Anticlockwise"
- the output value of a FT-instruction is to be output via the digital output of the frequency inverter (only possible with 2401 to 2404).

In parameter *FT-target output 1 1350* or *FT-target output 2 1351*, a target must be selected for the output value of the FT-instruction.

The output value of the FT-instruction is saved in this target, the selected signal source "FT-Output Buffer".

Example: Linking with device function. Link of output 2 of FT-instruction 1 (Index 1) to function "Start Anticlockwise":

- In Index 1 of function table:
FT-target output 2 1351 = "2401 - FT-Outp. Buffer 1".
- In VPlus:
Start Anticlockwise 69 = "2401 - FT-Outp. Buffer 1".

Example: Signal output via digital output. Link of output 2 of FT-instruction 1 (Index 1) to digital output S1OUT:

- In Index 1 of function table:
FT-target output 2 1351 = "2401 - FT-Outp. Buffer 1".
- In VPlus:
Op. Mode Digital Output 1 530 = "80 - FT-Output Buffer 1".

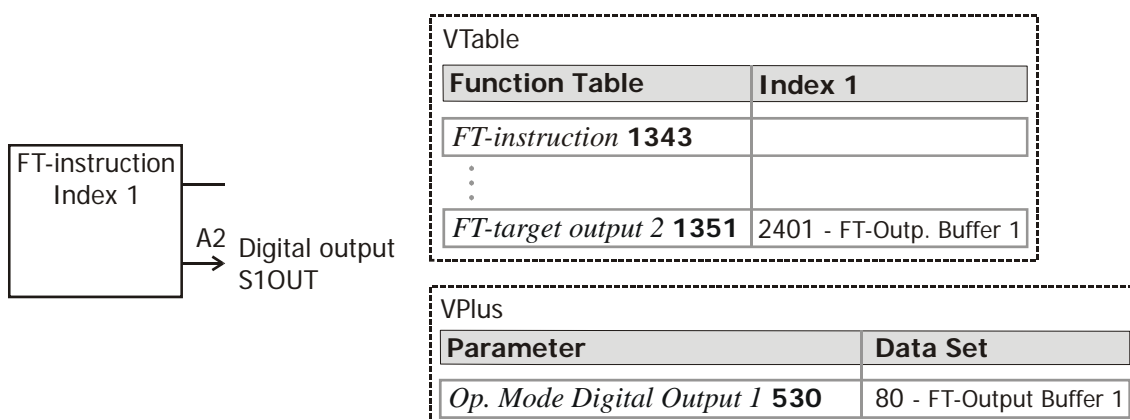

Signal source "**Output Instruction**": Signal sources 2101 to 2232 can be used if the output value of a FT instruction is to be present at the input of another FT-instruction. Signal sources 2201 to 2232 (Outp.2) are the inverted values of signal sources 2101 to 2132 (Outp. 1).

Example: Link of FT-Output 1 of FT-instruction 1 (Index 1) to FT-Input 3 of FT-instruction 2 (Index 2):

- In Index 2 of function table select:
FT-input 3 1346 = "2101 - Outp. 1 Instruction 1".

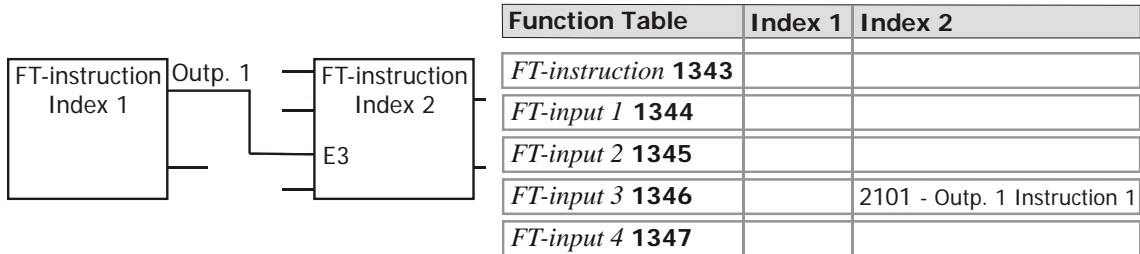

The four **Inputs** E1, E2, E3 and E4 of a FT-instruction can be linked with

- signal sources or digital inputs of input buffer or
- outputs of FT-instructions.

The parameters *FT-parameter 1 1348* and *FT-parameter 2 1349* enable, depending on the FT-instruction, setting of **delay times** or **jumps** between functions, for example.

The above schematic representations describe the general procedure for parameterization of the function table and are no actual application example.

3.2.2 Analog functions

 Click on button in VPlus to open the function table VTable.

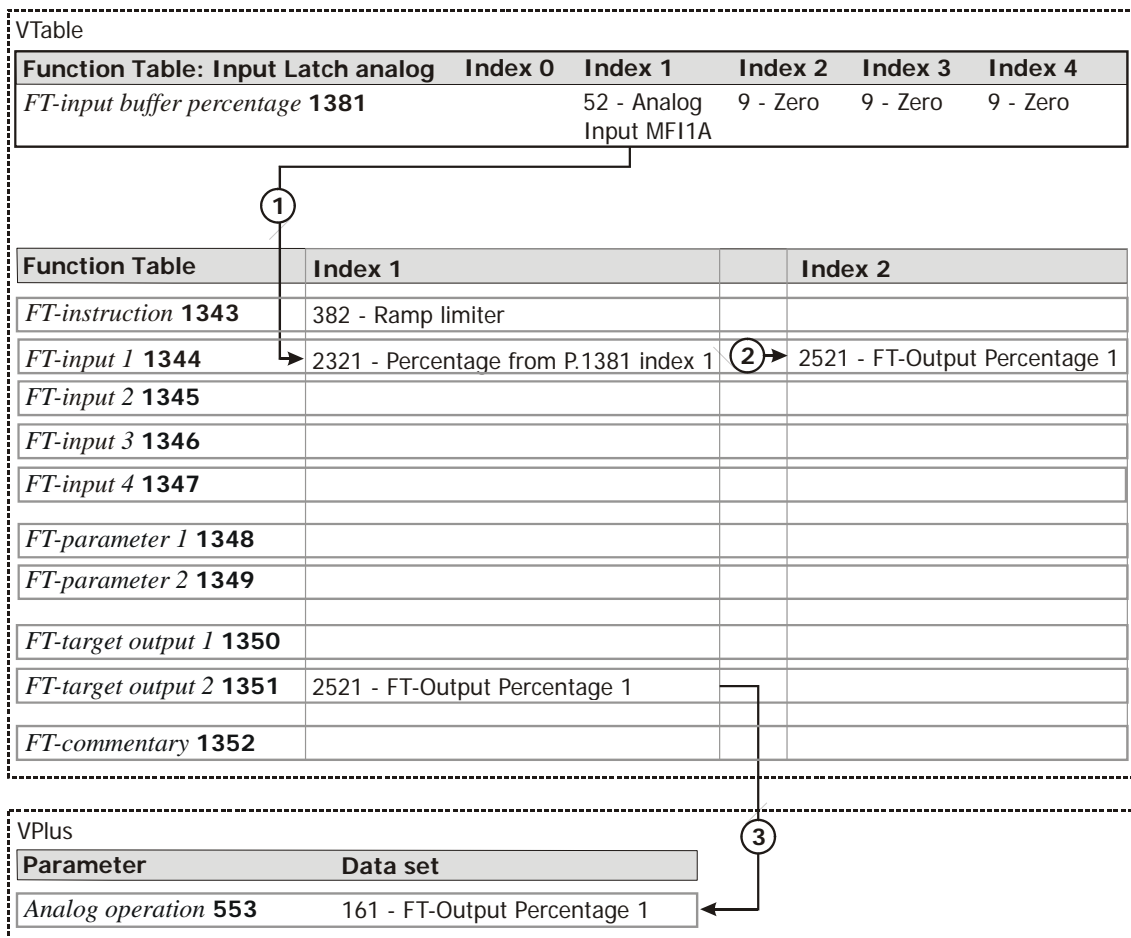

- ① Link the input of a FT-instruction to an analog signal source. Refer to chapter 3.7.3.2.
- ② Link the input of a FT-instruction to the output of a FT-instruction. Refer to chapter 3.7.4.2.
- ③ Output the output value of a FT-instruction via an analog output of the device. Refer to chapter 3.7.5.3.

FT: Function table

3.3 Run/Stop

By default (factory setting) the function table is stopped and must be started by parameter *FT-RunMode* 1399. In stop mode, no instructions are processed and there is no writing of the output buffer.

Note:

Instructions can only be edited in stop mode. If you try to make any changes while the function table is not in stop mode, an error will be displayed in VPlus. The change will not be taken over.

Further operation modes are available for processing individual instructions and instruction blocks. If an operation mode 11, 12, 21, 22, 31 or 32 is selected, the instruction block¹ will be processed according to the function described. Then, Run mode will be set to "0-Stop" automatically. In order to process another application block, the operation mode must be set to the corresponding value again.

<i>FT-Runmode 1399</i>	Function
0 - Stop	The function table is stopped and no longer processed.
1 - Run	The function table is started at index 1 and processed normally.
2 - Continue	The function table is continued at the index where the processing was stopped last time, and the table is then processed normally.
11 - Single Step 12 - Single Step	One instruction is processed.
21 - Single Part 22 - Single Part	All instructions are processed until next writing of output buffer.
31 - Single Cycle 32 - Single Cycle	All instructions are processed until return jump. The return jump is reached when the maximum number of logic functions is processed or the next <i>FT-instruction 1343</i> = 0.

Note:

Two modes are available to an instruction block (1x, 2x, 3x).

For control of a **PLC** it is sufficient to select a mode and set it accordingly. When the instruction block was processed, the frequency inverter resets the operation mode to "0-Stop" automatically. The same mode can be selected again.

Note:

If a diagnosis via **VPlus** is to be performed, both modes are required. Execution of the instruction block must be started by the modes alternately, because VPlus only updates parameters (on ACU) which have been changed.

Note:

If "Single Step", "Single Part" or "Single Cycle" are selected, the selected mode is maintained. The status of the function table is shown in *FT-actual values function 1356*.

3.3.1 Example Run/Stop

The following diagram shows a function block circuit which includes two jump functions (J1 and J2). Depending on the settings of parameter *FT-RunMode 1399*, the procedure is as follows:

FT-RunMode 1399 = "1 – Run"

The sequence is processed continuously. Jump functions are processed according to input statuses.

FT-RunMode 1399 = "11 – Single Step", "12 – Single Step"

The sequence is interrupted after each instruction. Each time, the sequence is stopped, *FT-RunMode 1399* must be restarted with "11 – Single Step" or "12 – Single Step". Jump functions are processed according to input statuses. Thus, the sequence is "I=1, Stop"; "I=2, Stop";...

FT-RunMode 1399 = "21 – Single Part", "22 – Single Part"

The sequence is processed until a jump instruction is reached which writes the output buffer. In this example, the buffer is written by both jump instructions. Thus, the sequence is "Block A, Stop"; "Block B, Stop";...

¹ An instruction block may consist of a single instruction.

FT-RunMode **1399** = "31 – Single Cycle", "32 – Single Cycle"

The sequence is processed until the end is reached and the return jump to the start is affected (to block C). It may happen that Block B is processed repeatedly depending on the digital signals if the jump at J2 jumps to the beginning of Block B. A cycle may be, for example: "Block A, Block B, Block B, Block B, Block B, Block C, return jump, stop".

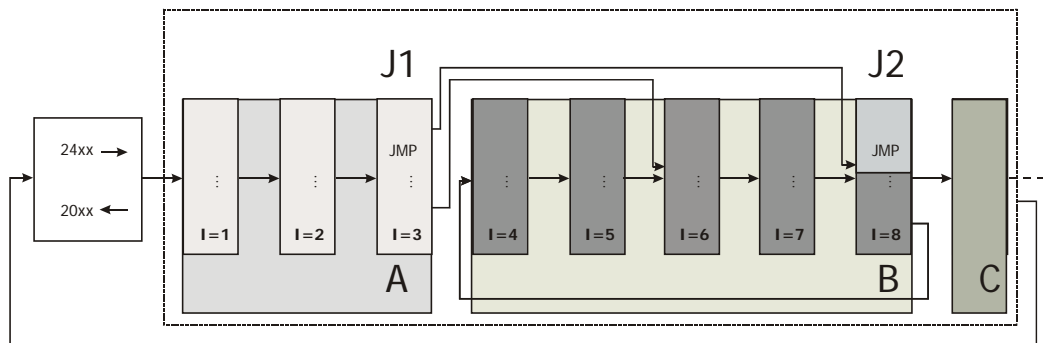

3.4 Comment field

In order to make the parameterization readily readable, one comment field is available per instruction. This can be used for entering a brief description for easier diagnosis. Comments of a length of up to 16 characters can be entered in parameter *FT-commentary* **1352**.

Example:

FT-commentary **1352** = "Jump to Block 2"

3.5 Overview of functions

3.5.1 Overview table

<i>FT-instruction</i> 1343	Function
Digital-Functions	
0 - Off (last table item)	Return jump to FT-instruction 1 (in Index 1). Last function processed in function table. Refer to chapter 2.1.
Boolean Functions	
1 - AND	Up to 4 inputs are AND-linked to one another. Output is TRUE if all inputs are TRUE. Refer to chapter 4.3.1.
2 - OR	Up to 4 inputs are OR-linked to one another. Output is TRUE if at least one input is TRUE. Refer to chapter 4.3.2.
3 - XOR 1	Up to 4 inputs are EXCLUSIVE OR-linked to one another. Output is TRUE only if TRUE is present on exactly one input. Refer to chapter 4.3.3.
4 - XOR 1 3	Up to 4 inputs are EXCLUSIVE OR-linked to one another. The output is TRUE only if TRUE is present on an odd number of inputs. The output is FALSE only if TRUE is present on an even number of inputs. Refer to chapter 4.3.4.
Flip-Flop-Types	
10 - RS FlipFlop Superior	Input 1: Set; TRUE sets output to TRUE. Input 2: Reset; TRUE sets output to FALSE. Input 3: Superior-Set; TRUE sets output to TRUE. Input 4: Superior-Reset; TRUE sets output to FALSE. FALSE at Set and Reset: Last output signal state is maintained. Refer to chapter 4.4.1.
20 - Toggle FlipFlop Superior	Output signal changes with the positive pulse edge at input 1 or with the negative pulse edge at input 2. TRUE at Superior-Set input (input 3) sets output TRUE. TRUE at Superior-Reset input (input 4) sets output FALSE. Refer to chapter 4.4.3.

<i>FT-instruction 1343</i>	Function
30 - D FlipFlop Superior	If a positive edge is received at input 1 (clock pulse input C, Clock) the signal present at input 2 (data input D) is transferred to the output. TRUE at Superior-Set input (input 3) sets output TRUE. TRUE at Superior-Reset input (input 4) sets output FALSE. Refer to chapter 4.4.5.
Delays	
40 - Delay Superior ms (retriggerable)	The positive edge at input 1 is delayed by the time set in <i>FT-parameter 1 1348</i> and the negative edge is delayed by the time set in <i>FT-parameter 2 1349</i> before switching them through to the output. The delay time starts again with each edge. Times are indicated in milliseconds [ms]. TRUE at Superior-Set input (input 3) sets output TRUE. TRUE at Superior-Reset input (input 4) sets output FALSE. Refer to chapter 4.5.1.
41 - Delay Superior s (retriggerable)	Like operation mode 40, but times set in <i>FT-parameter 1 1348</i> and <i>FT-parameter 2 1349</i> are indicated in seconds [s]. Refer to chapter 4.5.1.
42 - Delay Superior min (retriggerable)	Like operation mode 40, but times set in <i>FT-parameter 1 1348</i> and <i>FT-parameter 2 1349</i> are indicated in minutes [min]. Refer to chapter 4.5.1.
50 - Delay Superior ms (not retriggerable)	The positive edge at input 1 {Parameter <i>FT-input 1 1344</i> } is delayed by the time set in <i>FT-parameter 1 1348</i> and the negative edge is delayed by the time set in <i>FT-parameter 2 1349</i> before switching them through to the output. During the delay time, edges will be ignored. Times are indicated in milliseconds [ms]. TRUE at Superior-Set input (input 3) sets output TRUE. TRUE at Superior-Reset input (input 4) sets output FALSE. Refer to chapter 4.5.3.
51 - Delay Superior s (not retriggerable)	Like operation mode 50, but times set in <i>FT-parameter 1 1348</i> and <i>FT-parameter 2 1349</i> are indicated in seconds [s]. Refer to chapter 4.5.3.
52 - Delay Superior min (not retriggerable)	Like operation mode 50, but times set in <i>FT-parameter 1 1348</i> and <i>FT-parameter 2 1349</i> are indicated in minutes [min]. Refer to chapter 4.5.3.
Timer-Functions	
60 - Monoflop Superior ms (retriggerable)	Output signal becomes TRUE with positive clock edge at input 1 or with negative clock edge at input 2. The time set in <i>FT-parameter 1 1348</i> is the On-Time (High) and the time set in <i>FT-parameter 2 1349</i> is the ignore edge time (Low). The time is indicated in milliseconds [ms]. The set on-time and the ignore edge time start again with each edge. TRUE at Superior-Set input (input 3) sets output TRUE. TRUE at Superior-Reset input (input 4) sets output FALSE. Refer to chapter 4.6.1.
61 - Monoflop Superior s (retriggerable)	Like operation mode 60, but times set in <i>FT-parameter 1 1348</i> and <i>FT-parameter 2 1349</i> are indicated in seconds [s]. Refer to chapter 4.6.1.
62 - Monoflop Superior min (retriggerable)	Like operation mode 60, but times set in <i>FT-parameter 1 1348</i> and <i>FT-parameter 2 1349</i> are indicated in minutes [min]. Refer to chapter 4.6.1.

<i>FT-instruction 1343</i>	Function
70 - Monoflop Superior ms (not retriggerable)	Output signal becomes TRUE with positive clock edge at input 1 or with negative clock edge at input 2. The time set in <i>FT-parameter 1 1348</i> is the On-Time (High) and the time set in <i>FT-parameter 2 1349</i> is the ignore edge time (Low). The time is indicated in milliseconds [ms]. Edges during the selected ON time and the ignore edge time will be ignored. TRUE at Superior-Set input (input 3) sets output TRUE. TRUE at Superior-Reset input (input 4) sets output FALSE. Refer to chapter 4.6.3.
71 - Monoflop Superior s (not retriggerable)	Like operation mode 70, but times set in <i>FT-parameter 1 1348</i> and <i>FT-parameter 2 1349</i> are indicated in seconds [s]. Refer to chapter 4.6.3.
72 - Monoflop Superior min (not retriggerable)	Like operation mode 70, but times set in <i>FT-parameter 1 1348</i> and <i>FT-parameter 2 1349</i> are indicated in minutes [min]. Refer to chapter 4.6.3.
80 - Clock Generator Superior ms	As long as input 1 is TRUE and input 2 is FALSE, the set pulse pattern is output. The clock pattern is defined by the on-time and the off-time. The time set in <i>FT-parameter 1 1348</i> is the on-time (High) and the time set in <i>FT-parameter 2 1349</i> is the off-time (Low). The time is indicated in milliseconds [ms]. TRUE at Superior-Set input (input 3) sets output TRUE. TRUE at Superior-Reset input (input 4) sets output FALSE. Refer to chapter 4.6.5.
81 - Clock Generator Superior s	Like operation mode 80, but times set in <i>FT-parameter 1 1348</i> and <i>FT-parameter 2 1349</i> are indicated in seconds [s]. Refer to chapter 4.6.5.
82 - Clock Generator Superior min	Like operation mode 80, but times set in <i>FT-parameter 1 1348</i> and <i>FT-parameter 2 1349</i> are indicated in minutes [min]. Refer to chapter 4.6.5.
Digital switches Digital functions	
90 - Digital Multiplexor (data set no.)	Depending on the current data set, the input values are passed on to the output values Data set = 1: Output 1 = Input 1, Data set = 2: Output 1 = Input 2, Data set = 3: Output 1 = Input 3, Data set = 4: Output 1 = Input 4 Refer to chapter 4.7.1.
91 - Switch Data Set	Switching-over of data set depending on input signals. Refer to chapter 4.8.1.
Fault functions Digital functions	
95 - Trigger a Fault	One of the inputs can trigger a user fault. The behavior of the user fault (fault stop, shut down, emergency stop) can be set in P2. Refer to chapter 4.9.1.
96 - Reset a Fault	The output 1 displays, if a resettable fault is active. With inputs E1 or E2 the fault can be reset. Refer to chapter 4.9.2.
No operation Digital functions	
99 - NOP	No operation. Refer to chapter 4.11.1.
Jump functions Digital functions	
100 - Jump function	Branching off to table column (index). Refer to chapter 4.12.1.
101 - Jump function for loops	A function which is jump target is defined in P1 is executed as often as defined in P2. The inputs can end or start again the loop. Refer to Chapter 4.12.2.
110 ... 182	Like instruction types 10 ... 82. Evaluation of Master-Set/Master-Reset instead of Superior-Set/Superior-Reset.
Analog functions	
Debouncer Analog functions	
97 - Debouncer	The input value is only put to the output after the set delay time (P1: positive edge, P2: negative edge) is stable constant at the input. Refer to chapter 4.10.1.

FT-instruction 1343		Function
Bit-functions for analog input values		Analog functions
200 - Bit by Bit NOT	Input E1 is inverted bit by bit and put to the output 1. Refer to chapter 5.11.1.	
201 - Bit by Bit AND/NAND	Input E1 is used for an AND operation. P2 defines: P2=1: operation with E2, P2=2: operation with a fixed mask set in P1, P2=3: operation with E2 and a fixed mask set in P1 Refer to chapter 5.11.2.	
202 - Bit by Bit OR/NOR	Input E1 is used for an OR/NOR operation. P2 defines: P2=1: operation with E2, P2=2: operation with a fixed mask set in P1, P2=3: operation with E2 and a fixed mask set in P1 Refer to chapter 5.11.3.	
203 - Bit by Bit XOR/XNOR	Input E1 is used for an XOR operation. P2 defines: P2=1: operation with E2, P2=2: operation with a fixed mask set in P1, P2=3: operation with E2, the result is used for the operation with a fixed mask set in P1 Refer to chapter 5.11.4.	
210 - Bit Shift right	Input E1 is shift right for the specified number of shifts (P2). On the left side, Zeros fill up the analog value. Refer to chapter 5.11.5.	
211 - Bit arithm. Shift Right	Input E1 is shift right for the specified number of shifts (P2). The highest bit (sign-bit) remains unaffected. Refer to chapter 5.11.6.	
212 - Bit Shift left	Input E1 is shift left for the specified number of shifts (P2). On the right side, Zeros fill up the analog value. Refer to chapter 5.11.7.	
213 - Bit Roll right	Input E1 is shift right for the specified number of shifts (P2). On the left side the bits are inserted that are pushed out on the right side. Refer to chapter 5.11.8.	
220 - Output 1 Bit	A selected Bit of input E1 is put out on output A1. The bit is selected via P1. Refer to chapter 5.11.9.	
221 - Merge 4 Bits to 1 Word	The status of input 1 is copied into the output bit which is designated in P1. The status of input 2 is copied into the next bit and so on. Refer to chapter 5.11.10.	
222 - Add 2 Bits to 1 Word	The status of the inputs E2 and E3 are copied into designated bits of the input value 1. The bits are designated by P1 and P2. Refer to chapter 5.11.11.	
Comparator		Analog functions
301 - Comp. (V V)	Input E1 and E2 are compared. A hysteresis can be defined via P1 and P2. Refer to chapter 5.2.1.	
302 - Comp. (V V), value	Like Operation mode 301, with the difference that the absolute values are compared. Refer to chapter 5.2.1.	
303 - Comp. (C V)	Two threshold values are specified. If the input E1 exceeds the higher threshold P1, the output is switched on. If the input falls below the lower threshold P2, the output is switched off. Refer to chapter 5.2.2.	
304 - Comp. (C V), value	Like Operation mode 303, with the difference that the absolute values of E1 is compared with the thresholds P1 and P2 (Constants). Refer to chapter 5.2.2.	
308 - Comp. Active Motion Block (of table posit.)	A range of motion blocks is specified. If a motion block is active in this defined range P1 to P2, the output is set to TRUE. Refer to chapter 5.2.3.	
309 - Comp. (P P)	It is checked, if the value at input E1 is higher than the value at E2. Via P1 and P2 a hysteresis can be specified. Refer to chapter 5.2.4.	
310 - Analogue Hysteresis	Input value E1 applies constantly at output A1 when a start signal at E3 is set. The hysteresis is set via variable E2 and constant P1. Then the output value alters only if input value E1 exceeds or falls below the hysteresis. Refer to chapter 5.2.5.	
311 - Window-comparator (V V)	It is checked, if E1 is in a specified range (window) around E2. Refer to chapter 5.2.6.	

FT-instruction 1343		Function
312 -	Window-comparator (V V), value	Like Operation mode 311 with the difference that the absolute values of E1 and E2 are checked. Refer to chapter 5.2.6.
313 -	Window-comparator (C V)	A value range (window) is specified. It is checked, if the value of E1 is inside this area. Refer to chapter 5.2.7.
314 -	Window-comparator (C V), value	Like Operation mode 311 with the difference that the absolute value of E1 is checked. Refer to chapter 5.2.7.
320 -	Min / Max	The variables E1, E2 and the constants P1 and P2 are checked. The minimum or maximum value is determined and set to output A1. Refer to chapter 5.2.8.
321 -	Min / Max for Position values	The variables E1, E2 (position values) and the constants P1 and P2 are checked. The minimum or maximum value is determined and set to output A1. Refer to chapter 5.2.9.
322 -	Min / Max in time window	Over a defined time determined minimal input value E1 is put to output A1. Or: Over a defined time determined maximum input value E1 is put to output A1. Or: The actual value E1 is put to output A1. Refer to chapter 5.2.10.
323 -	Min / Max for Positions in time window	Over a defined time determined minimal input value E1 is put to output A1. Or: Over a defined time determined maximum input value E1 is put to output A1. Or: The actual value E1 is put to output A1. Refer to chapter 5.2.11.
Mathematical Functions		Analog functions
330 -	Addition $A1 = -A2 = E1 + E2 - E3 + P1 - P2$	The input values E1 and E2 are added and the input value E3 is subtracted. Additional a P1 adds a positive offset, P2 a negative offset. P1 is added to the result and P2 is subtracted from the result. Refer to chapter 5.3.1.1.
331 -	Addition long $A1 = E1 + E2 - E3 + P$	The input values E1 and E2 (long values) are added and the input value E3 (long value) is subtracted. Additional an offset can be defined with P. P1 is High-Byte, P2 is Low-Byte. Refer to chapter 5.3.1.2.
332 -	Multiplication $(A1 = E1 * E2 * P1)$	The input values E1 and E2 are multiplied together with parameter value P1. Refer to chapter 5.3.2.1.
333 -	Multiplication with result long $(A = E1 * E2 * P1)$	The input values E1 and E2 are multiplied together with parameter value P1. The result is split in Low-word and High-word and put out at outputs A1 and A2. Refer to chapter 5.3.2.2.
334 -	Multiplication with fraction $(A1 = E1 * P1/P2)$	The input value E1 is multiplied with parameter value P1 and divided by parameter value P2. Refer to chapter 5.3.2.3.
335 -	Multiplication long * Percent	Refer to chapter 5.3.2.4.
336 -	Division $A1 = (E1/E2/E3)$	The input value E1 is divided by input value E2. Refer to chapter 5.3.3.1.
337 -	Division $A1 = E1/P1$	The input value E1 is divided by parameter value P1. Refer to chapter 5.3.3.2.
338 -	Division $A1 = P1/E1$	The parameter value E1 is divided by input value P1. Refer to chapter 5.3.3.3.

FT-instruction 1343	Function
339 - Multiplication and Division $A1 = (E1 * E2)/E3$	The input value E1 is multiplied with input value E2. The result is divided by E3. Refer to chapter 5.3.4.
340 - Average-function	The average value of input values E1, E2 and E3 is calculated. Refer to chapter 5.3.5.
341 - Value of two orthogonal components	The orthogonal (perpendicular) input values E1 and E2 are used to calculate the absolute value. Refer to chapter 5.3.6.
342 - Value of three orthogonal components	The orthogonal (perpendicular) input values E1, E2 and E3 are used to calculate the absolute value. Refer to chapter 5.3.7.
350 - Integrator ($A1 = \int E1 dt$)	The input value E1 is integrated. Refer to chapter 5.3.8.
351 - Differentiator (D-Element) ($A1 = dE1/dt$)	The input value E1 is differentiated. Refer to chapter 5.3.9.
360 - Absolute Value	The absolute value of input value E1 is determined. Refer to chapter 5.3.10.
361 - X^2	Input value E1 is multiplied with itself (square). Refer to chapter 5.3.11.
362 - X^3	Input value E1 is raised to the power of 3. Refer to chapter 5.3.12.
363 - SQRT(X)	Square root of input value E1. Refer to chapter 5.3.13.
Controller Analog functions	
370 - P-Controller	The control deviation (E1 – E2) is multiplied with the amplification P1. Refer to chapter 5.4.1.
371 - PI-Controller (Tn in milliseconds)	The control deviation (E1 – E2) is multiplied with the amplification P1 and the integral element (sum of the control deviations during the time) is added. The unit of the integral time is milliseconds. Refer to chapter 5.4.2.
372 - PI-Controller (Tn in seconds)	The control deviation (E1 – E2) is multiplied with the amplification P1 and the integral element (sum of the control deviations during the time) is added. The unit of the integral time is seconds. Refer to chapter 5.4.3.
373 - PD (T1)-Controller	The control deviation (E1 – E2) is multiplied with the amplification P1. The differential element is added. Refer to chapter 5.4.4.
374 - PID (T1)-Controller (Tn in milliseconds)	The control deviation (E1 – E2) is multiplied with the amplification (=1). The integral and differential elements are added. For setting of other amplifications a P-controller must be connected ahead. The unit of the integral time is milliseconds. Refer to chapter 5.4.5.
375 - PID (T1)-Controller (Tn in seconds)	The control deviation (E1 – E2) is multiplied with the amplification (=1). The integral and differential elements are added. For setting of other amplifications a P-controller must be connected ahead. The unit of the integral time is seconds. Refer to chapter 5.4.6.
Filter Analog functions	
380 - PT1-element	Input value E1 is filtered according to the filter time constant. Refer to chapter 5.5.1.
381 - Time average	The mean value of the input values at E1 (during a specified time) is generated. Refer to chapter 5.5.2.
382 - Ramp limiter	The output value follows the input value with limited ramp slope. The ramp slope can be set. Refer to chapter 5.5.3.
383 - Spike Filter (Middle of three)	The input value at E1 is filtered from peak values. Refer to chapter 5.5.4.
Analog switches Analog functions	
390 - Analogue Multiplexer (data set no.)	Output of one of the input values E1 ... E4 dependent on the active data set. Refer to chapter 5.6.1.
391 - Analog Switch	Output of one of the values E1, E2, E3 or P2. Refer to chapter 5.6.2.

<i>FT-instruction 1343</i>		Function
392 -	MUX for position values (data set no.)	Output of one of the values E1, E2 or P (P1 P2). Refer to chapter 5.6.3.
393 -	Switch for position values	Output of one of the input values E1 ... E4 dependent on the active data set. Refer to chapter 5.6.4.
Parameter access (read and write parameters)		Analog functions
401 -	Write frequency parameter	The input value is converted from Percent to Hertz and written as long-parameter. Refer to chapter 5.7.1.1.
402 -	Write current parameter	The input value is converted from Percent to Ampere and written as int-parameter. Refer to chapter 5.7.1.2.
403 -	Write voltage p. (eff.)	The rms value at the input is converted from Percent to Volt and written as int-parameter. Refer to chapter 5.7.1.3.
404 -	Write voltage p. (peak)	The peak value at the input is converted from Percent to Volt and written as int-parameter. Refer to chapter 5.7.1.4.
405 -	Write Perc. Parameter	The unchanged input value is written as int-parameter. Refer to chapter 5.7.1.5.
406 -	Write Position Parameter	The unchanged input value is written as long-parameter. Refer to chapter 5.7.1.6.
407 -	Write Long Parameter	The input value is Low-word and High-word compounded and written unchanged as long-parameter. For usage of any long-parameter types. Refer to chapter 5.7.1.7.
408 -	Write Word Parameter	Refer to chapter 5.7.1.8.
421 -	Read frequency parameter	This function reads in the value of the parameter set in 1348 "Parameter number" and 1349 "Data set/Index". The value is transformed into a frequency value. Refer to chapter 5.7.2.1.
422 -	Read current parameter	This function reads in the value of the parameter set in 1348 "Parameter number" and 1349 "Data set/Index". The value is transformed into a current value. Refer to chapter 5.7.2.2.
423 -	Read voltage p. (eff.)	This function reads in the value of the parameter set in 1348 "Parameter number" and 1349 "Data set/Index". The value is transformed into a voltage value. Refer to chapter 5.7.2.3.
424 -	Read voltage p. (peak)	This function reads in the value of the parameter set in 1348 "Parameter number" and 1349 "Data set/Index". The value is transformed into a voltage value. Refer to chapter 5.7.2.4.
425 -	Read Perc. Parameter	This function reads in the value of the parameter set in 1348 "Parameter number" and 1349 "Data set/Index". The value is transformed into a Percentage value. Refer to chapter 5.7.2.5.
426 -	Read Position Parameter	This function reads in the value of the parameter set in 1348 "Parameter number" and 1349 "Data set/Index". The value is transformed into a Position value. Refer to chapter 5.7.2.6.
427 -	Read long parameter	This function reads in the value of the parameter set in 1348 "Parameter number" and 1349 "Data set/Index". The value is transformed into a Long value. Refer to chapter 5.7.2.7.
428 -	Read Word Parameter	Refer to chapter 5.7.2.8.
Limiters		Analog functions
440 -	Limiters (Const.)	The input value at E1 is limited to P1 at the upper limit and P2 at the lower limit and output. Refer to chapter 5.8.1.
441 -	Limiters (Variable)	The input value at E1 is limited to E2 at the upper limit and -E3 at the lower limit and output. Refer to chapter 5.8.2.
Counter		Analog functions
450 -	Up/Down Counter with analogue output	The output value of the counter increases by 100.00%/P1 with every positive signal edge at E1. The output value of the counter decreases by 100.00%/P2 with every positive signal edge at E2. Refer to chapter 5.9.1.
451 -	Clock with analogue output	The clock runs if E1 = „TRUE“ and E2 = „FALSE“. E3 designates the direction. E4 sets the clock to the initial value P1. A divisor for output value scaling can be set via P2. Refer to chapter 5.9.2.

<i>FT-instruction 1343</i>		Function
Positioning functions		Analog functions
501 -	Start Motion Block (Single mode)	The motion block which has been set in P1 is started. Input E1 designates the target position. Input E2 designates the reference speed value. The actual position value is output. Repetitions and next motion blocks are not executed. Refer to chapter 5.10.1.
502 -	Start Motion Block (Automatic mode)	The motion block which has been set in P1 is started. Input E1 designates the target position. Input E2 designates the reference speed value. Repetitions and next motion blocks are executed. The actual position value is output. Refer to chapter 5.10.2.
503 -	Motion Block: Interrupt	The active motion block is interrupted if input E3 is set. The drive stops. If input E3 is reset the interrupted motion block is resumed, repetitions and next motion blocks are executed. The actual position value is output. Refer to chapter 5.10.3.
504 -	Motion Block: Continue	An interrupted motion block is resumed if input E3 is set. The actual position value is output. Refer to chapter 5.10.4.
505 -	Motion Block: Resume	A motion block which has been interrupted by mains switch-off or mains failure is resumed when input E3 is set. The actual position value is output. Refer to chapter 5.10.5.
506 -	Start Homing	The homing mode which has been set in P1 is started when input E3 is set. The actual position value is output. Refer to chapter 5.10.6.
507 -	Check state	If a motion block is active the output A1 is set to TRUE. Refer to chapter 5.10.7.

3.6 Inputs and outputs

3.6.1 Inputs

In the following the functions of the input parameters of the FT-instructions dependent on the setting of *FT-instruction 1343* are described.

3.6.2 Inputs of the digital functions

The digital functions use digital input signals and a digital output signal.

The following table summarizes the usage of the separate inputs. The output is always a digital signal with the evaluated result of the FT-instruction.

<i>FT-instruction 1343</i>	<i>FT-input 1</i> 1344	<i>FT-input 2</i> 1345	<i>FT-Input 3</i> 1346	<i>FT-input 4</i> 1347
0 - OFF (last table item)	-	-	-	-
1 - AND	Input 1	Input 2	Input 3	Input 4
2 - OR	Input 1	Input 2	Input 3	Input 4
3 - XOR 1	Input 1	Input 2	Input 3	Input 4
4 - XOR 1 3	Input 1	Input 2	Input 3	Input 4
10 - RS FlipFlop Superior	Set	Reset	Superior-Set	Superior-Reset
20 - Toggle FlipFlop Superior	Input +	Input -	Superior-Set	Superior-Reset
30 - D FlipFlop Superior	Clock input C	Data input D	Superior-Set	Superior-Reset
4x - Delay Superior (retriggerable)	Input	-	Superior-Set	Superior-Reset
5x - Delay Superior (not retriggerable)	Input	-	Superior-Set	Superior-Reset
6x - Monoflop Superior (retriggerable)	Input +	Input -	Superior-Set	Superior-Reset
7x - Monoflop Superior (not retriggerable)	Input +	Input -	Superior-Set	Superior-Reset
8x - Clock Generator Superior	Input +	Input -	Superior-Set	Superior-Reset

<i>FT-instruction 1343</i>		<i>FT-input 1 1344</i>	<i>FT-input 2 1345</i>	<i>FT-Input 3 1346</i>	<i>FT-input 4 1347</i>
90 -	Digital Multiplexor (data set no.)	Input 1	Input 2	Input 3	Input 4
91 -	Switch Data Set	Input 1	Input 2	Input 3	Input 4
95 -	Trigger a Fault	Trigger	Trigger	Trigger	Trigger
96 -	Reset a Fault	Reset	Reset	-	-
97 -	Debouncer	Input	-	Master-Set	Master-Set
99 -	NOP				
100 -	Jump Function	Activate jump function	Jump target	Update input buffer	Update output buffer
101 -	Jump Function for loops	Interrupt loop	Restart loop	Update input buffer	Update output buffer
110 -	RS FlipFlop Master	Set	Reset	Master-Set	Master-Reset
120 -	Toggle FlipFlop Master	Input +	Input -	Master-Set	Master-Reset
130 -	D FlipFlop Master	Clock input C	Data input D	Master-Set	Master-Reset
14x -	Delay Master (retriggerable)	Input	-	Master-Set	Master-Reset
15x -	Delay Master (not retriggerable)	Input	-	Master-Set	Master-Reset
16x -	Monoflop Master (retriggerable)	Input +	Input -	Master-Set	Master-Reset
17x -	Monoflop Master (not retriggerable)	Input +	Input -	Master-Set	Master-Reset
18x -	Clock Generator Master	Input +	Input -	Master-Set	Master-Reset

Note:

In instruction types 40 to 82 as well as 140 to 182 the "x" is used as a placeholder in the table. The instruction types can be parameterized in three different time bases:

- 0: milliseconds [ms],
- 1: seconds [s],
- 2: minutes [min].

3.6.3 Inputs and outputs of the analog functions

The analog functions use at least one analog input signal or output signal. Dependent on the FT-instruction the inputs and outputs provide various functions.

<i>FT-instruction 1343</i>	<i>FT-input</i>				<i>FT-output</i>		<i>FT-parameter</i>	
	<i>I 1344</i>	<i>2 1345</i>	<i>3 1346</i>	<i>4 1347</i>	<i>A1</i>	<i>A2</i>	<i>P1 1348</i>	<i>P2 1349</i>
200 - Bit by Bit NOT	%	-	b	b	%	%	-	-
201 - Bit by Bit AND/NAND	%	%	b	b	%	%	%	i
202 - Bit by Bit OR/NOR	%	%	b	b	%	%	%	i
203 - Bit by Bit XOR/XNOR	%	%	b	b	%	%	%	i
210 - Bit Shift right	%	-	b	b	%	%	-	i
211 - Bit arithm. Shift Right	%	-	b	b	%	%	-	i
212 - Bit Shift left	%	-	b	b	%	%	-	i
213 - Bit Roll right	%	-	b	b	%	%	-	i
220 - Output 1 Bit	%	-	b	b	b	b	i	-
221 - Merge 4 Bits to 1 Word	b	b	b	b	%	%	i	-
222 - Add 2 Bits to 1 Word	%	b	b	b	%	%	i	i
301 - Comp. (V V)	%	%	b	b	b	b	xxx.xx%	xxx.xx%
302 - Comp. (V V), value	%	%	b	b	b	b	%	%
303 - Comp. (C V)	%	-	b	b	b	b	%	%
304 - Comp. (C V), value	%	-	b	b	b	b	%	%
308 - Comp. Active Motion Block	-	-	b	b	b	b	i	i

FT-instruction 1343	FT-input				FT-output		FT-parameter	
	1 1344	2 1345	3 1346	4 1347	A1	A2	P1 1348	P2 1349
309 - Comp. (P P)	Pos	Pos	b	b	b	b	Pos	Pos
310 - Analogue Hysteresis	%	%	b	b	b	b	%	%
311 - W.-comp. (V V)	%	%	b	b	b	b	%	%
312 - W.-comp. (V V), value	%	%	b	b	b	b	%	%
313 - W.-comp. (C V)	%	-	b	b	b	b	%	%
314 - W.-comp. (C V), value	%	-	b	b	b	b	%	%
320 - Min / Max	%	%	b	b	%	%	%	%
321 - Min / Max for Position values	Pos	Pos	b	b	Pos	Pos	Pos	Pos
322 - Min / Max in time window	%	-	b	b	%	%	-	-
323 - Min / Max for Positions in time window	Pos	-	b	b	Pos	Pos	-	-
330 - Add. A1=-A2=E1+E2-E3+P1-P2	%	%	%	b	%	%	%	%
331 - Add. long A1 = E1 + E2 - E3 + P	Pos	Pos	Pos	b	Pos	Pos	Pos	Pos
332 - Mult. (A1 = E1 * E2 * P1)	%	%	-	b	%	%	%	-
333 - Mult. w. result long (A = E1 * E2 * P1)	%	%	-	b	%	%	%	-
334 - Mult. w. fraction (A1 = E1 * P1 / P2)	%	-	-	b	%	%	%	%
335 - Mult. long * Percent	%	%	%	b	%	%	%	%
336 - Div. A1 =(E1 / E2 / E3)	%	-	-	b	%	%	%	%
337 - Div. A1 =(E1 / P1)	%	-	-	b	%	%	%	%
338 - Div. A1 =(P1 / E1)	%	%	%	b	%	%	%	%
339 - Mult. & Div (A1 = (E1 * E2) / E3)	%	%	%	b	%	%	%	%
340 - Average function	%	%	%	b	%	%	i	i
341 - Value of two orthogonal components	%	%	-	b	%	%	%	%
342 - Value of three orthogonal components	%	%	%	b	%	%	%	%
350 - Integrator (A1 = Int(E1 * dt))	%	%	b	b	%	%	i	i
351 - Differentiator (D-element) (A1 = dE1/dt)	%	-	-	b	%	%	%	-
360 - Absolute Value	%	-	-	b	%	%	-	-
361 - X^2	%	-	-	b	%	%	-	%
362 - X^3	%	-	-	b	%	%	-	%
363 - SQRT(X)	%	-	-	b	%	%	-	%
370 - P-Controller	%	%	-	b	%	%	i	%
371 - PI-Controller (Tn in milliseconds)	%	%	%	b	%	%	i	i
372 - PI-Controller (Tn in seconds)	%	%	%	b	%	%	i	i
373 - PD (T1)-Controller	%	%	%	b	%	%	i	i
374 - PID (T1)-Controller (Tn in milliseconds)	%	%	%	b	%	%	i	i
375 - PID (T1)-Controller (Tn in seconds)	%	%	%	b	%	%	i	i
380 - PT1-element	%	%	b	b	%	%	i	-
381 - Time average	%	-	-	b	%	%	-	-

<i>FT-instruction</i>	<i>FT-input</i>				<i>FT-output</i>		<i>FT-parameter</i>	
	<i>1</i>	<i>2</i>	<i>3</i>	<i>4</i>	<i>A1</i>	<i>A2</i>	<i>P1</i>	<i>P2</i>
	1344	1345	1346	1347			1348	1349
382 - Ramp limiter	%	%	b	b	%	%	%	i
383 - Spike Filter (Middle of three)	%	%	b	b	%	%	-	-
390 - Analogue Multiplexer (data set no.)	%	%	%	%	%	%	-	-
391 - Analog Switch	%	%	b	b	%	%	%	%
392 - MUX for position values (data set no.)	Pos	Pos	Pos	Pos	Pos	Pos	-	-
393 - Switch for position values	Pos	Pos	b	b	Pos	Pos	Pos	Pos
401 - Write frequency parameter	%	-	b	b	b	b	i	i
402 - Write current parameter	%	-	b	b	b	b	i	i
403 - Write voltage p. (eff.)	%	-	b	b	b	b	i	i
404 - Write voltage p. (peak)	%	-	b	b	b	b	i	i
405 - Write Perc. Parameter	%	-	b	b	b	b	i	i
406 - Write Position Parameter	Pos	-	b	b	b	b	i	i
407 - Write Long Parameter	%	%	b	b	b	b	i	i
408 - Write Word Parameter								
421 - Read frequency parameter	-	-	b	-	%	%	i	i
422 - Read current parameter	-	-	b	-	%	%	i	i
423 - Read voltage p. (eff.)	-	-	b	-	%	%	i	i
424 - Read voltage p. (peak)	-	-	b	-	%	%	i	i
425 - Read Perc. Parameter	-	-	b	-	%	%	i	i
426 - Read Position Parameter	-	-	b	-	%	%	i	i
427 - Read Long Parameter	-	-	b	-	%	%	i	i
428 - Read Word Parameter	-	-	b	-	%	%	i	i
440 - Limiter (Const.)	%	-	-	b	%	%	%	%
441 - Limiter (Variable)	%	%	%	b	%	%	-	-
450 - Up/Down Counter with analogue output	b	b	b	b	%	%	i	i
451 - Clock with analogue output	b	b	b	b	%	%	i	i
501 - Start Motion Block (Single mode)	Pos	%	b	b	Pos	Pos	i	-
502 - Start Motion Block (Automatic mode)	Pos	%	b	b	Pos	Pos	i	-
503 - Motion Block: Interrupt	-	-	b	b	Pos	Pos	-	-
504 - Motion Block: Continue	-	-	b	b	Pos	Pos	-	-
505 - Motion Block: Resume	-	-	b	b	Pos	Pos	-	-
506 - Start Homing	-	-	b	b	Pos	Pos	i	-
507 - Check state	-	-	b	b	Pos	Pos	i	-

3.7 Linking of inputs and outputs of FT-instructions

Inputs

Each FT-instruction has 4 inputs. The inputs can be linked to outputs of other FT-instructions (within the function table) or, outside of the function table, to digital inputs or global signal sources.

Outputs

Each FT-instruction has 2 outputs. The two outputs:

- can be linked to inputs of other FT-instructions (within function table);
- can be linked to device functions outside of the function table;
- can be used for digital or analog signal output at device terminals

In digital functions, output 2 has the negated logic state of input 1.

Note:

Changing the instructions (Parameters **1343...1351**) is only possible in stop mode (*FT-RunMmode 1399* = "0-Stop"). If you try to make any changes while the function table is not in stop mode, an error will be displayed in VPlus. The change will not be taken over.

3.7.1 FT-inputs

The FT-inputs can either be linked to the FT-input buffer, FT-fixed values, the outputs of other instructions (normal or inverted) or the global output variables (digital: FT-Output Buffer or analog: FT-Output Frequency, FT-Output Current etc).

Note:

Note that the FT-output buffer is updated only with a write operation (e.g. during return jump). The value used originates from the last write operation of the FT-Output Buffer.

Possible digital signal sources for <i>FT-input 1 1344, FT-input 2 1345, FT-input 3 1346, FT-input 4 1347</i>	
6	TRUE
7	FALSE
Link to digital signal source – selected in an index 1 ... 16 of parameter <i>FT-input buffer 1362</i>	
2001 ... 2016	FT-Input Buffer 1 ... 16
Link to digital output (<i>FT-target output 1 1350, FT-target output 2 1351</i>) of FT-instruction	
2101 ... 2132	Outp. 1 Instruction 1 ... 32
2201 ... 2232	Outp. 2 Instruction 1 ... 32
Link to analog signal source – selected in an index 1 ... 4 of table "Function Table: Input Latch analog"	
2301 ... 2304	Frequency from P. 1379 index 1 ... 4
2311 ... 2314	Current from P. 1380 index 1 ... 4
2321 ... 2324	Percentage from P.1381 index 1 ... 4
2331 ... 2334	Voltage from P. 1382 index 1 ... 4
2341	Actual position (of motion block)
2351 ... 2354	General source from P. 1383 index 1 ... 4
Link to constants	
2380 ... 2392	Auxiliary numbers (constants) and global Flags (State signals)
Link to digital global signal sources of the function table	
2401 ... 2416	FT-Output Buffer 1 ... 16
Link to analog output (<i>FT-target output 1 1350, FT-target output 2 1351</i>) of FT-instruction	
2501 ... 2504	FT-Output Frequency 1 ... 4

Possible digital signal sources for <i>FT-input 1 1344, FT-input 2 1345, FT-input 3 1346, FT-input 4 1347</i>	
2511 ... 2514	FT-Output Current 1 ... 4
2521 ... 2524	FT-Output Percentage 1 ... 4
2531 ... 2534	FT-Output Voltage 1 ... 4
2551 ... 2554	FT-Output General value 1 ... 4
2561 ... 2564	FT-Marker 1 ... 4
Link to analog fixed value	
2601 ... 2604	Fixed val. Freq. P. 1388 Index 1 ... 4
2611 ... 2614	Fixed val. Curr. P. 1389 Index 1 ... 4
2621 ... 2624	Fixed val. Perc. P. 1390 Index 1 ... 4
2631 ... 2634	Fixed val. Volt.rms P. 1391 Index 1 ... 4
2641 ... 2644	Fixed val. Volt.pk P. 1391 Index 1 ... 4
2651 ... 2654	Fixed val. general P. 1395 Index 1 ... 4
2661 ... 2664	Fixed val. Position P. 1392 Index 1 ... 4
2671 ... 2674	Fix. val. Speed Pos. P. 1393 Index 1 ... 4
2681 ... 2684	Fix. val. Ramp Pos. P. 1394 Index 1 ... 4

2380 ... 2392 – Auxiliary numbers (constants) and global Flags (State signals)

2380 - "0,00 (Zero Percent)":

The auxiliary number has the constant value 0%.

2381 - "100,00 (Hundred Percent)":

The auxiliary number has the constant value 100%

2382 - "327,67 (Maximum value)":

The auxiliary number has the constant value 327.67%

2383 - "0xFFFF (for Bit operations)":

The auxiliary number has the constant hexadecimal value 0xFFFF and can be used for bit by bit operations.

2384 - F_{max} (100):

The auxiliary number has the constant value 100% of F_{max} (of parameter value *Maximum Frequency* **419**).

2385 - "Motor rated current in actual data set":

The auxiliary number is related to parameter value *Rated Current* **371** in the current data set. The constant value applies as percentage value at the input of the FT-instruction: 100% corresponds to the motor rated current.

2386 - "Short time Overload current (ILIMIT)":

The auxiliary number is related to the type-dependent overload current. The constant value applies as percentage value at the input of the FT-instruction: 100% corresponds to the overload current value.

2387 - "TF_INIT":

This status signal is „TRUE“ during 64 ms time period:

- after power supply switch-on or
- after start of table functions.

Otherwise signal status is FALSE. The signal can be linked to Master-Set und Master-Reset-inputs and enables function initialization.

2388 - "TF_RESET":

This status signal is „TRUE“ during 64 ms time period:

- after power supply switch-on or
- after start of table functions or
- after output stage disabling.

Otherwise signal status is FALSE. The signal can be linked to Master-Set und Master-Reset-inputs and enables function initialization.

2389 - "TF_IDLE":

This status signal is „TRUE“ when the output stage is disabled.

2390 - "TF_Controller release":

This status signal is „TRUE“ when the output stage is enabled and flux forming (magnetizing) is finished; the drive runs.

2391 - "TF_Controller release inverted":

This signal is the inverted status signal "TF_Controller release".

2392 - "TF_Fault_Quittable":

This status signal is TRUE if a current error can be acknowledged.

3.7.2 FT-target outputs

Via parameters *FT-target output 1 1350* and *FT-target output 2 1351*, FT-Outputs A1 and A2 (digital functions: A2 = inverted A1) can also be used outside of the function table.

Parameter	Possible signal sources	
<i>FT-target output 1 1350</i> <i>FT-target output 2 1351</i>	Digital	
	2401 ... 2416	FT-Outp. Buffer 1 ... 16
	2501 ... 2504	FT-Output Frequency 1 ... 4
	Analog	
	2511 ... 2514	FT-Output Current 1 ... 4
	2521 ... 2524	FT-Output Percentage 1 ... 4
	2531 ... 2534	FT-Output Voltage 1 ... 4
	2551 ... 2554	FT-Output General value 1 ... 4
	2561 ... 2564	FT-Marker 1 ... 4
Digital outputs of the device	80 ... 83	FT-Output Buffer 1 ... 4
	180 ... 183	Inv. FT- Output Buffer 1 ... 4
Analog outputs of the device	61 ... 62	Abs. Val. FT-Output Percentage 1 ... 2
	161 ... 162	FT-Output Percentage 1 ... 2

Note:

The FT-output buffer is updated only with a write operation (e.g. during return jump).

3.7.3 Digital: Linking FT-input buffer with FT-inputs

3.7.3.1 Digital

If the signal of a digital input (e.g. S4IND) or a signal source (e.g. 162 - Error Signal) is to be present at the input of a FT-instruction, an index of parameter *FT-input buffer 1362* to this digital input or signal source must be set. As a result, the digital input or signal source is available for the inputs of the FT-instructions. Indices 1 to 16 of parameter *FT-input buffer 1362* are set, by default, to the digital inputs of the frequency inverter and frequently used signal sources. Parameters *FT-input 1 1344* to *FT-input 4 1347* must be set to the required digital inputs or signal sources 2001...2016.

The digital input or signal source for a FT-instruction input is indicated in the following index of parameter *FT-input buffer 1362*:

For a link to a FT-instruction input select for a parameter *FT-input 1 1344* to *FT-input 4 1347*:

Index	Factory setting	Signal source
Index 1	70 - Inverter Release (on S1IND)	2001 - FT-Input Buffer 1
Index 2	71 - S2IND	2002 - FT-Input Buffer 2
...
Index 16	7 - Off	2016 - FT-Input Buffer 16

1. Example: Link of a FT-instruction input to a **digital input**: The signal on digital input S4IND is to be present at input 3 of instruction 5 (index 5 of table).

- Selection in index 4 of parameter *FT-input buffer 1362*, for example: *FT-input buffer 1362* = "73 - S4IND" (factory setting). As a result, the digital input is available for the inputs of the FT-instructions. Another index can also be used for selecting the digital input.
- Selection in index 5 of function table: *FT-Input 3 1346* = "2004 - Input Buffer 4".

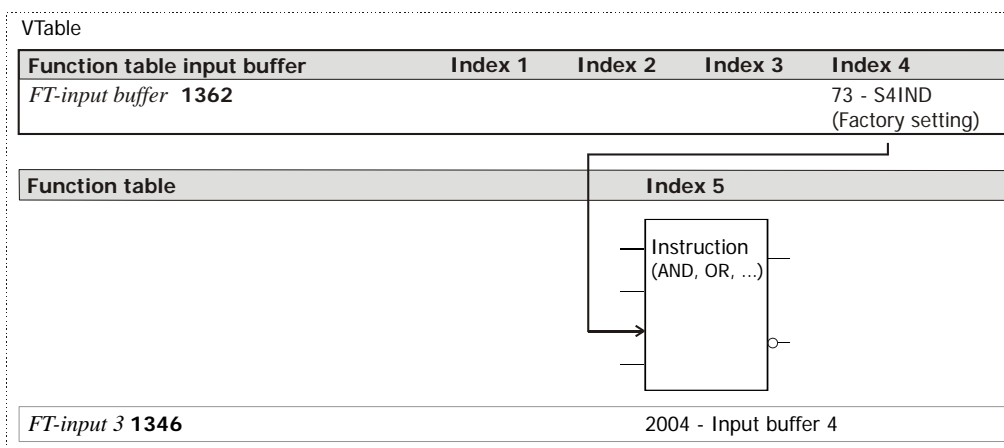

2. Example: Link of a FT-instruction input to a **signal source**: The signal "Warning Motor Temperature" is to be present at input 1 of function 2 (index 2 of table).

- Selection in index 1 of parameter *FT-input buffer 1362*, for example: *FT-input buffer 1362* = "168 - Warning Motor Temperature". As a result, the signal source is available for the inputs of the FT-instructions. Another index can also be used for selecting the signal source.
- Selection in index 2 of function table: *FT-input 1 1344* = "2001 - Input Buffer 1".

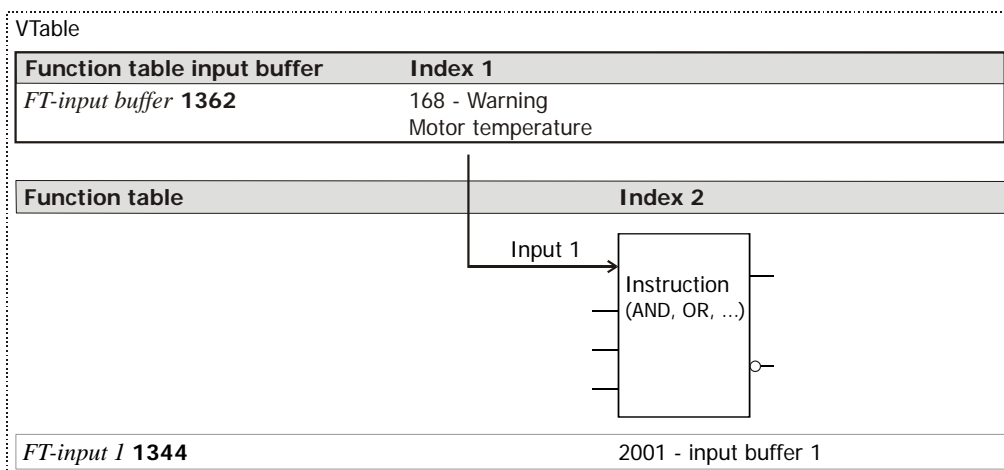

3.7.3.2 Analog

Link signal source to instruction input

If the signal of an analog input (e.g. MF11A) or a signal source (e.g. "10 - Stator Frequency") is to be present at the input of a FT-instruction, a parameter 1379 ... 1383 must be set to this analog input or signal source. As a result, the analog input or signal source is available for the inputs of the FT-instructions. Parameters *FT-input 1* **1344** to *FT-input 4* **1347** must be set to the required signal sources 23xx.

Input Latch analog		<i>FT-input 1</i> 1344 to <i>FT-input 4</i> 1347 =
Index	Factory setting	Signal source
<i>FT-input buffer frequency</i> 1379		
Index 1 ... 4	7 - FALSE	2301 ... 2304 - Frequency from P.1379 index 1 ... 4
<i>FT-input buffer current</i> 1380		
Index 1 ... 4	7 - FALSE	2311 ... 2314 - Current from P.1380 index 1 ... 4
<i>FT-input buffer percentage</i> 1381		
Index 1 ... 4	7 - FALSE	2321 ... 2324 - Percentage from P.1381 index 1 ... 4
<i>FT-input buffer voltage</i> 1382		
Index 1 ... 4	7 - FALSE	2331 ... 2334 - Voltage from P.1382 index 1 ... 4
<i>FT-input buffer gen. source</i> 1383		
Index 1 ... 4	7 - FALSE	2351 ... 2354 - General source from P.1383 index 1 ... 4

Example: Link of FT-instruction input to signal source: Stator frequency is to be present at input 3 of instruction 5 (index 5 of function table).

- Selection in index 4 of "Function Table: Input Latch analog", for example:
FT-input buffer frequency **1379** = "10 - Stator Frequency". As a result, the signal is available for the inputs of the FT-instructions.
 Another index can also be used for selecting the stator frequency.
- Selection in index 5 of function table:
FT-Input 1 **1344** = "2304 - Frequency from P.1379 index 4".

VTable

Function Table: Input Latch analog	Index 1	Index 2	Index 3	Index 4
<i>FT-input buffer frequency</i> 1379				10 - Stator Frequency
Function Table	Index 5			
<i>FT-input 3</i> 1346				2304 - Frequency from P.1379 index 4

Link fixed value to instruction input

If an analog fixed value (e.g. fixed frequency value) is to be present at the input of a FT-instruction, a parameter 1388 ... 1395 must be set in an index of the table "Input Latch analog". As a result, the fixed value is available for the inputs of the FT-instructions. Parameters *FT-input 1* **1344** to *FT-input 4* **1347** must be set to the required signal sources 26xx.

Input Latch analog		<i>FT-input 1</i> 1344 to <i>FT-input 4</i> 1347 =
Index	Factory setting	Signal source
<i>FT-fixed value frequency</i> 1388		
Index 1 ... 4	50 Hz	2601 ... 2604 - Fixed val. Freq. P.1388 Index 1 ... 4
<i>FT-fixed value current</i> 1389		
Index 1 ... 4	4,0 A	2611 ... 2614 - Fixed val. Curr. P.1389 Index 1 ... 4
<i>FT-fixed value percentage</i> 1390		
Index 1 ... 4	100.00%	2621 ... 2624 - Fixed val. Perc. P.1390 Index 1 ... 4
<i>FT-fixed value voltage</i> 1391		
Index 1 ... 4	565.7 V	2631 ... 2634 - Fixed val. Volt.rms P.1391 I. 1 ... 4 2641 ... 2644 - Fixed val. Volt.pk P.1391 I. 1 ... 4

Input Latch analog		<i>FT-input 1 1344</i> to <i>FT-input 4 1347</i> =
Index	Factory setting	Signal source
<i>FT-fixed value general 1395</i>		
Index 1 ... 4	0	2651 ... 2654 - Fixed val. general P.1395 I. 1 ... 4
<i>FT-fixed value position 1392</i>		
Index 1 ... 4	65536 units	2661 ... 2664 - Fixed val. Position P.1392 I. 1 ... 4
<i>FT-fixed value speed Pos. 1393</i>		
Index 1 ... 4	163840 u/s	2671 ... 2674 - Fix. val. Speed Pos. P.1393 I. 1 ... 4
<i>FT-fixed value ramp Pos. 1394</i>		
Index 1 ... 4	327680 u/s ²	2681 ... 2684 - Fix. val. Ramp Pos. P.1394 I. 1 ... 4

Example: Link of FT-instruction input to fixed value: An adjusted current value is to be present at input 1 of instruction 3 (index 3 of function table).

- Selection in index 2 of "Function Table: Input Latch analog", for example:
FT-fixed value current 1389 = 4.0 A. As a result, the signal is available for the inputs of the FT-instructions.
Another index can also be used for selecting the current value.
- Selection in index 3 of function table:
FT-Input 1 1344 = "2612 - Fixed val. Curr. P.1389 Index 2".

VTable

Function Table: Input Latch analog	Index 1	Index 2	Index 3	Index 4
<i>FT-fixed value current 1389</i>		4.0 A		
Function Table	Index 3			
<i>FT-input 1 1344</i>	2612 - Fixed val. Curr. P.1389 Index 2			

3.7.4 Linking instructions to one another (FT-Input)

The outputs of the FT-instructions parameterized in the table are available as signal sources to inputs of FT-instructions. The outputs of the FT-instructions can be linked to inputs of FT-instructions via parameters *FT-input 1 1344* to *FT-input 4 1347*.

3.7.4.1 Digital

Outputs of FT-Instructions as signal sources for FT-instruction inputs:

*FT-input 1 1344, FT-input 2 1345,
FT-Input 3 1346, FT-input 4 1347*

Digital

Output 1 of FT-instruction xx 21xx -	Output 2 (negated) of FT-instruction xx 22xx -
2101 - Outp. 1 Instruction 1	2201 - Outp. 2 Instruction 1
2102 - Outp. 1 Instruction 2	2202 - Outp. 2 Instruction 2
2103 - Outp. 1 Instruction 3	2203 - Outp. 2 Instruction 3
2104 - Outp. 1 Instruction 4	2204 - Outp. 2 Instruction 4
·	·
·	·
·	·
2131 - Outp. 1 Instruction 31	2231 - Outp. 2 Instruction 31
2132 - Outp. 1 Instruction 32	2232 - Outp. 2 Instruction 32

Example of link of FT-instruction input to an FT-instruction output: Output 1 of FT-instruction 2 (index 2 of function table) is required for linking to another logic function. The logic status of the output is to be present at input 2 of instruction 3 (Index 3 of function table).

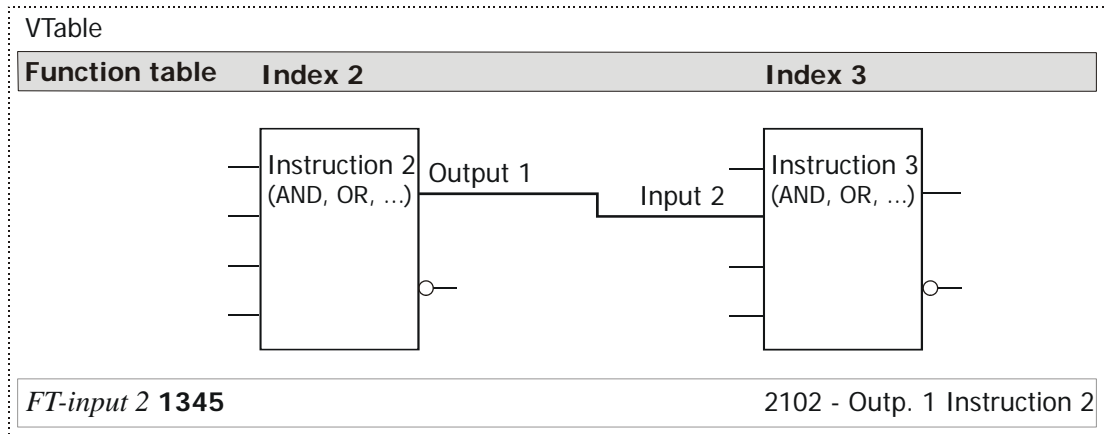

- In Index 3 of function table, set: Parameter *FT-input 2 1345* = "2102 - Outp. 1 Instruction 2".

3.7.4.2 Analog

Outputs of FT-Instructions as signal sources for FT-instruction inputs:

<i>FT-input 1 1344, FT-input 2 1345, FT-Input 3 1346, FT-input 4 1347</i>	
Output 1 of FT-instruction xx 21xx -	Output 2 of FT-instruction xx 22xx -
2101 - Outp. 1 Instruction 1	2201 - Outp. 2 Instruction 1
2102 - Outp. 1 Instruction 2	2202 - Outp. 2 Instruction 2
2103 - Outp. 1 Instruction 3	2203 - Outp. 2 Instruction 3
2104 - Outp. 1 Instruction 4	2204 - Outp. 2 Instruction 4
⋮	⋮
2131 - Outp. 1 Instruction 31	2231 - Outp. 2 Instruction 31
2132 - Outp. 1 Instruction 32	2232 - Outp. 2 Instruction 32
Link to output buffer signals	
2501 ... 2504 - FT-Output Frequency 1 ... 4	
2511 ... 2514 - FT-Output Current 1 ... 4	
2521 ... 2524 - FT-Output Percentage 1 ... 4	
2531 ... 2534 - FT-Output Voltage 1 ... 4	
2551 ... 2554 - FT-Output General value 1 ... 4	
2561 ... 2564 - FT-Marker 1 ... 4	

Example of link of FT-instruction input to an FT-instruction output: Output value of FT-instruction 2 (index 2 of function table) is required for linking to another analog function. The output value is to be present at input 1 of instruction 3 (index 3 of function table).

VTable		
Function Table	Index 2	Index 3
<i>FT-input 1 1344</i>		2102 - Outp. 1 Instruction 2

or

VTable		
Function Table	Index 2	Index 3
<i>FT-input 1 1344</i>		2531 - FT-Output Voltage 1
<i>FT-target output 1 1350</i>	2531 - FT-Output Voltage 1	

3.7.5 Linking output buffers (FT-target output)

Global sources for linking FT-instruction output to device functions outside of function table

The outputs of the FT-instructions parameterized in the function table can be made available to device functions outside of the logic table as global signal sources. Outputs 1 and 2 of the FT-instructions can be defined as general (global) signal sources via parameters *FT-target output 1 1350* and *FT-target output 2 1351* for processing further device functions.

Outputs of FT-Instructions as signal sources for device functions:

<i>FT-target output 1 1350 and FT-target output 2 1351</i>		
Digital and analog		
0 - Output not usable globally		
2401 - FT-Output Buffer 1	<ul style="list-style-type: none"> – Selection for <i>FT-target output 1 1350</i>: Output 1 of the FT-instruction is available to other device functions outside of the function table as general signal source. – Selection for <i>FT-target output 2 1351</i>: Output 2 of the FT-instruction is available to other device functions outside of the function table as general signal source. 	
2402 - FT-Output Buffer 2		
2403 - FT-Output Buffer 3		
.		
.		
.		
2415 - FT-Output Buffer 15		
2416 - FT-Output Buffer 16		
Analog		
2501 ... 2504 - FT-Output Frequency 1		
2511 ... 2514 - FT-Output Current 1		
2521 ... 2524 - FT-Output Percentage 1		
2531 ... 2534 - FT-Output Voltage 1		
2551 ... 2554 - FT-Output General value 1		
2561 ... 2564 - FT-Marker 1		

Note:

The current output values of the FT-instructions are updated during a return jump or a write command of a jump instruction.

3.7.5.1 Activating device functions via the output buffer

If the logic state of the output is to activate a device function which cannot be selected in the function table, one of the signal sources "24xx FT-Output Buffer xx" must be selected for the output. As a result, the output is generally (globally) available to other device functions. The selected signal source must also be assigned to the device function to be activated. Up to 16 signal sources (index 1 to 16) can be used for further processing of logic states of FT-instruction outputs. A signal source can be assigned to several outputs of FT-instructions. For example, *FT-target output 1 1350* = "2401 - FT-Output Buffer 1" may be selected both in index 1 and in index 2.

Example 1: Linking a FT-instruction output to a device function outside of the function table: Function "Start Anticlockwise" is to be activated via output 1 of function 2 (index 2 of the table).

- Selection in index 2 of table:
FT-target output 1 1350 = "2401 - FT-Outp. Buffer 1" (alternative selection also possible)
 As a result, the output is generally (globally) available to other device functions.
- Selection outside of function table:
Start Anticlockwise 69 = "2401 - FT-Output Buffer 1" (according to selection for *FT-target output 1 1350*).

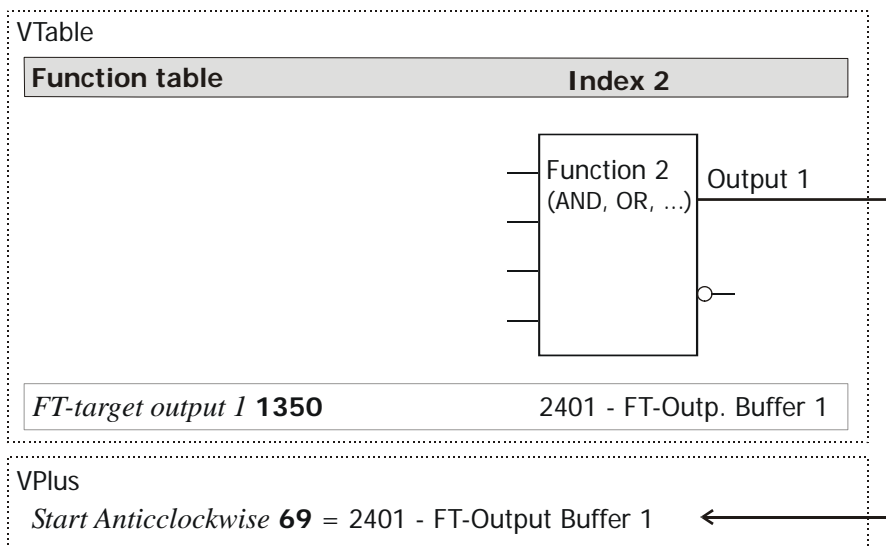

Example 2: Linking a FT-instruction output to a device function outside of the function table: Output of instruction 3 (index 3 of function table) is required for linking to another device function. This function is no FT-instruction of the table and cannot be selected in the table (for parameter *FT-instruction 1343*). Output 2 of instruction 3 is to be defined as a general (global) signal source and activates the device function "Switch Data Set 1".

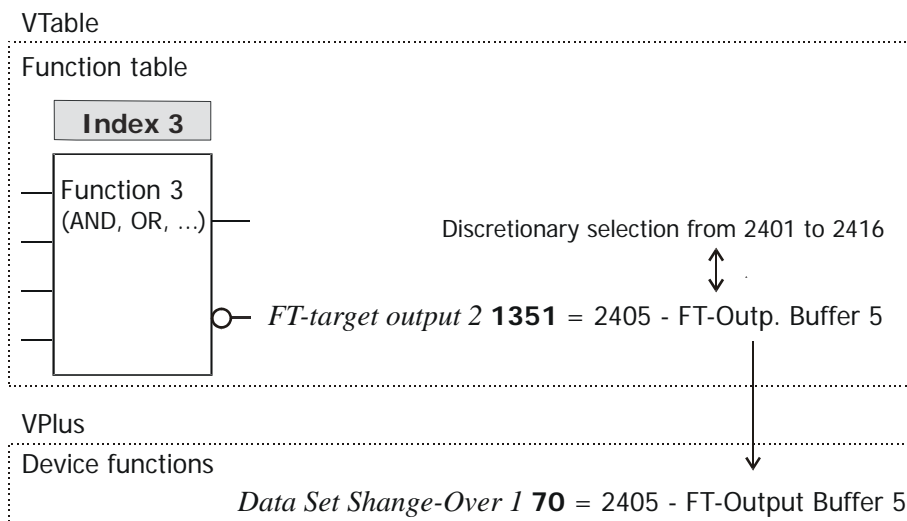

- Select a signal source for output 2 of FT-instruction 3, e.g. "2405 - FT-Output Buffer 5". This means, the following can be set in index 3 of the function table:
Parameter *FT-target output 2 1351* = "2405 - FT-Output Buffer 5". As a result, the signal source is generally (globally) available for processing by other device functions. It is also possible to choose another signal source from signal sources 2401 to 2416 for the parameter.
- For parameter *Switch Data Set 1 70*, select signal source "2405 - FT-Output buffer 5".

Example 3: The output value of instruction 1 is to be transmitted via system bus. An expansion module with system bus is necessary.

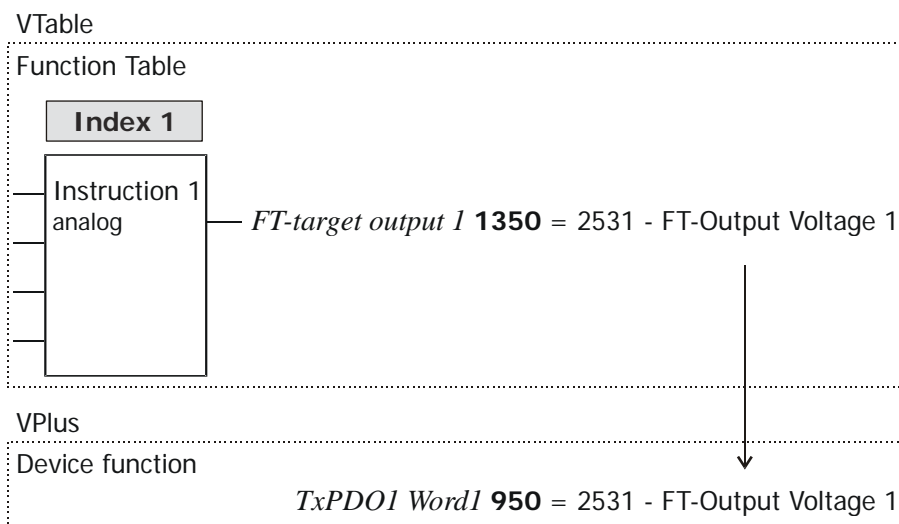

3.7.5.2 Controlling a digital output via the output buffer

The outputs of the FT-instructions can be output via digital outputs once they have been defined as general (global) signal sources.

For parameters *Op. Mode Digital Output 1 530*, *Op. Mode Digital Output 3 532* and *Digital Operation 554* (MFO1), you can choose among the following signal sources.

Outputs of FT-instructions as signal sources for digital outputs			
<i>FT-target output 1 1350</i>		Op. Mode 530, 532 & 554	
<i>FT-target output 2 1351</i>		Non-negated	Negated
2401 - FT-Outp. Buffer 1	↔	80	180
2402 - FT- Outp. Buffer 2		81	181
2403 - FT- Outp. Buffer 3		82	182
2404 - FT- Outp. Buffer 4		83	183

Example: Selection of signal source for digital output:

The output signal of instruction 15 (index 15 of function table) is to be output via digital output S1OUT.

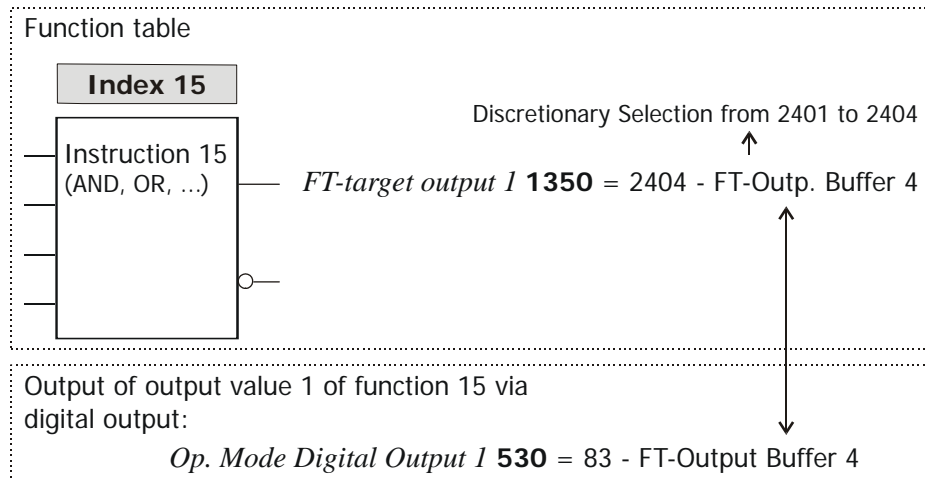

Output 1 of instruction 15 must be defined as a general (global) signal source:

- The following can be set in index 15 of the function table: Parameter *FT-target output 1 1350* = "2404 - FT-Outp. Buffer 4". As a result, the signal source is generally (globally) available for processing by other device functions and has the logic state of output 1 of instruction 15. It is also possible to choose another signal source from signal sources 2401 to 2404 for the parameter.

For a digital output, choose the general (global) signal source which contains output value 1 of FT-instruction 15:

- Parameter *Op. Mode Digital Output 1 530* = "83 - FT-Output Buffer 4" (according to signal source "FT-Output Buffer" set in parameter *FT-target output 1 1350*).

3.7.5.3 Controlling an analog output via the output buffer

The outputs of the FT-instructions can be output via analog outputs once they have been defined as general (global) signal sources.

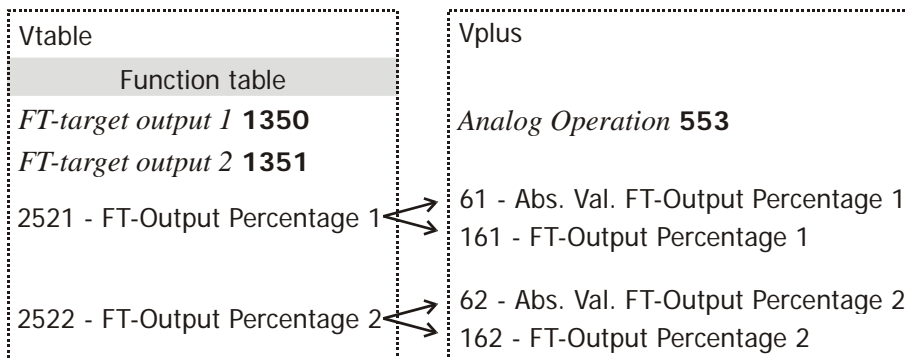

Example: The output signal of instruction 15 (index 15 of function table) is to be output via analog output MFO1A of the device.

VTable

Function Table

Index 1

Instruction 1
analog

FT-target output 1 **1350** = 2521 - FT-Output Percentage 1

VPlus

Analog output

Analog Operation **553** = 61 - Abs. Val. FT-Output Percentage 1

Operation Mode **550** = 2 - Analog

4 Explanation of the digital functions

In the following, you will find explanations and examples of the digital functions.

The following specification is described as digital function:

A digital function has at least one digital input value but no analog input value. The output value is digital.

In the examples, the standard links of the input buffer are used. You can also parameterize other settings for the individual instructions. The following symbols are used in the diagrams:

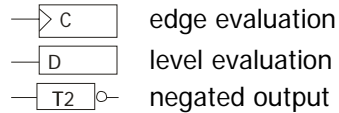

0	"Low" state. Represents logic states in logic tables.
1	"High" state. Represents logic states in logic tables.
FALSE	"Low" state. Represents logic states in function descriptions.
TRUE	"High" state. Represents logic states in function descriptions.
x	any state ("Don't care" – 0 or 1).
0 → 1	positive edge.
1 → 0	negative edge.
Q_{n-1}	last state is maintained.
$\overline{Q_{n-1}}$	last state is negated (toggle).
A_n	non-negated output
$\overline{A_n}$	negated output

Note:

For better clarity, the non-negated output A_n is used in the descriptions. The negated output $\overline{A_n}$ is available in each function and can be used.

For digital functions take into account:

- Unused inputs must be set to "7 - Off" (default setting of all FT-inputs).
Exception: Unused inputs of FT-instruction "AND" must be set to "6 - On".
- In all functions, output 2 has the inverted logic state of input 1.
- Clock inputs (T, C) evaluate signal edges.
- Set/Superior-Set/Master-Set inputs and Reset/Superior-Reset/Master-Reset inputs evaluate logic states.
- Reset has priority over Set.
- Times set for *FT-parameter 1 1348* and *FT-parameter 2 1349*, are limited internally to a max. value of 24 days.

4.1 Superior/Master

Via parameter *FT-instruction 1343*, the FT-instruction can be selected. For more details and examples, refer to Chapter 4.

Most instructions also enable setting of selective output statuses by overriding inputs. This may be used, for example, for initialization of a plant status.

There are two variants of instructions with overriding inputs.

Superior

- The function sequence is processed further internally in the instruction. The overriding inputs change the instruction output only for the time in which the overriding signal is present.
- During the set/reset phase, edges will also be detected and processed internally. If the Superior Set/Superior Reset Signal is no longer present, the output will take the value which would result without the Set/Reset Phase.
- The processing sequence can be compared to a series connection of the function and a logic AND operation with the superior inputs.

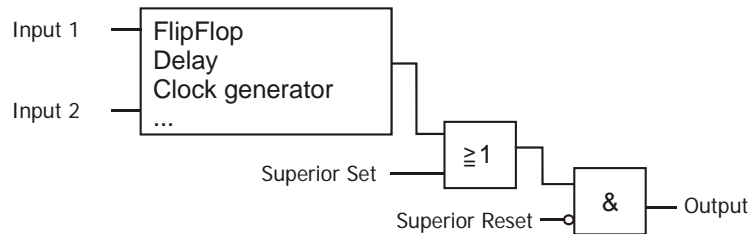

Master

- The function sequence is interrupted. The overriding inputs change the instruction output as from the time at which the overriding signal is present.
- Set/Reset signals are not evaluated as long as a Master-Set/Master-Reset is present.
- The processing sequence can be compared to a parallel connection of the function and the master inputs.

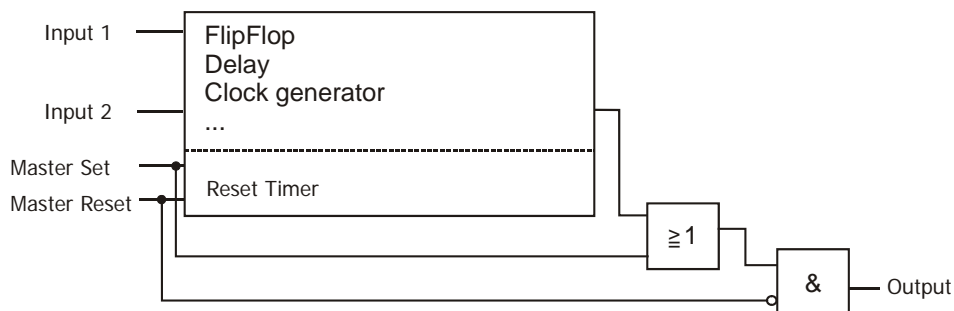

Superior

Superior-Set

Master

Master-Set

TRUE at Superior-Set/Master-Set switches instruction output 1 to TRUE directly.

Superior-Reset

Master-Reset

TRUE at Superior-Reset/Master-Reset switches instruction output 1 to FALSE directly. Reset has a higher priority than set.

4.2 Parameters for chronological behavior and jump target

The chronological behavior of the FT-instructions or a jump target can be adjusted via *FT-parameter 1* **1348** and *FT-parameter 2* **1349**.

4.2.1 Chronological behavior

The parameter settings affect the following functions:
 Selection for *FT-instruction 1343*:

40 ... 42 / 140 ... 142	Delay
50 ... 52 / 150 ... 152	
60 ... 62 / 160 ... 162	Monoflop
70 ... 72 / 170 ... 172	
80 ... 82 / 180 ... 182	Clock generator

Parameter		Setting		
No.	Description	Min.	Max.	Fact. sett.
1348	FT-parameter 1	0	Limited internally to 24 days	10
1349	FT-parameter 2	0		10

The units of *FT-parameter 1 1348* and *FT-parameter 2 1349* may be set to milliseconds [ms], seconds [s] or minutes [min]. The unit of the entered value depends on the setting of parameter *FT-instruction 1343*. If, for example, 50 is entered for *FT-parameter 1 1348* and *FT-instruction 1343* is set to "60 - Monoflop ms (retriggerable)", the on-time of the monoflop is 50 ms. If, however, *FT-instruction 1343* is set to "61 - Monoflop s (retriggerable)", the on-time of the monoflop is 50 s.

Note:

Times set for *FT-parameter 1 1348* and *FT-parameter 2 1349*

- are limited internally to the maximum value of 24 days
- are not continued when the frequency is switched off and on again. The sequence is restarted from the beginning after re-activation.

4.2.2 Jump target

The evaluation of parameters affect the following functions:
 Selection for *FT-instruction 1343*:

100	Jump function
-----	---------------

Parameter		Setting		
No.	Description	Min.	Max.	Fact. sett.
1348	FT-parameter 1	1	32	10
1349	FT-parameter 2	1	32	10

Note:

The table shows typical and reasonable setting options. Value 0 and values greater than 32 can be entered.

If value 0 or values greater than 32 are selected, a return jump is affected, and the processing of the functions is continued by updating the output and input buffer.

4.2.3 Overview table

The meaning of the settings of *FT-parameter 1 1348* and *FT-parameter 2 1349* depending on the settings of parameter *FT-instruction 1343* is shown in the following table.

<i>FT-instruction 1343</i>		<i>FT-parameter 1 1348</i>	<i>FT-parameter 2 1349</i>
40 - 140 -	Delay ms (retriggerable)	delay pos. edge [ms]	delay neg. edge [ms]
41 - 141 -	Delay s (retriggerable)	delay pos. edge [s]	delay neg. edge [s]
42 - 142 -	Delay min (retriggerable)	delay pos. edge [min]	delay neg. edge [min]
50 - 150 -	Delay ms (not retriggerable)	delay pos. edge [ms]	delay neg. edge [ms]
51 - 151 -	Delay s (not retriggerable)	delay pos. edge [s]	delay neg. edge [s]
52 - 152 -	Delay min (not retriggerable)	delay pos. edge [min]	delay neg. edge [min]
60 - 160 -	Monoflop ms (retriggerable)	ON time [ms]	ignore edge time [ms]
61 - 161 -	Monoflop s (retriggerable)	ON time [s]	ignore edge time [s]
62 - 162 -	Monoflop min (retriggerable)	ON time [min]	ignore edge time [min]
70 - 170 -	Monoflop ms (not retriggerable)	ON time [ms]	ignore edge time [ms]
71 - 171 -	Monoflop s (not retriggerable)	ON time [s]	ignore edge time [s]
72 - 172 -	Monoflop min (not retriggerable)	ON time [min]	ignore edge time [min]
80 - 180 -	Clock Generator ms	ON time [ms]	OFF time [ms]
81 - 181 -	Clock Generator s	ON time [s]	OFF time [s]
82 - 182 -	Clock Generator min	ON time [min]	OFF time [min]
100 -	Jump function	Jump target 1	Jump target 2

Note:

Operation modes < 40 to 82 use Superior inputs,
operation modes < 140 to 182 use Master inputs as overriding inputs.

Note:

In all other settings of parameter *FT-instruction 1343* not listed in the above table, setting of *FT-parameter 1 1348* and *FT-parameter 2 1349* have no effect on the FT-instruction. In setting "1 - AND", for example, the input of values for *FT-parameter 1 1348* and *FT-parameter 2 1349* will not be considered. For better readability, BONFIGLIOLI VECTRON recommends to set the parameter values to "0" in these instructions.

4.3 Boolean operations

The following table shows the linking of the implemented Boolean functions. Logic 0s are indicated as dots.

Inputs				Output depending on logic function			
E1	E2	E3	E4	AND	OR	XOR 1	XOR 1 3
.	.	.	1	.	1	1	1
.	.	1	.	.	1	1	1
.	.	1	1	.	1	.	.
.	1	.	.	.	1	1	1
.	1	.	1	.	1	.	.
.	1	1	.	.	1	.	1
.	1	1	1	.	1	.	1
1	1	1	1
1	.	.	1	.	1	.	.
1	.	1	.	.	1	.	.
1	.	1	1	.	1	.	1
1	1	.	.	.	1	.	.
1	1	.	1	.	1	.	1
1	1	1	.	.	1	.	1
1	1	1	1	1	1	.	.

4.3.1 [1] AND link

	Par#	Type	Function		Par#	Type	Function
E1	1344	b	Input value 1	A1	1350	b	A1 = AND (E1 E2 E3 E4)
E2	1345	b	Input value 2	A2	1351	b	Inverted output A2 = A1
E3	1346	b	Input value 3	P1	1348		
E4	1347	b	Input value 4	P2	1349		

FT-instruction 1343 = "1 - AND"

Description:

The inputs are AND-linked to one another. The inputs of the instruction are the signal sources assigned (ACU functions, digital inputs). Output is TRUE if all inputs are TRUE. As soon as one input is FALSE, the output will be FALSE. The output signal can be used within the function table not-negated (21xx) and negated (22xx). The output signal is available via parameter *FT-target output 1* **1350**. Via parameter *FT-target output 2* **1351**, the inverted output signal is available.

Note:

Unused inputs must be set to "6 - TRUE". For example, *FT-Input 3* **1346** and *FT-input 4* **1347** must be set to "6 - TRUE" if inputs *FT-input 1* **1344** and *FT-input 2* **1345** are to be AND-linked only.

Example:

A1 =S5IND AND S6IND

<i>FT-input buffer</i> 1362	Index 1	Index 2	Index 3	Index 4	Index 5	Index 6	...
	74-S5IND	75-S6IND	...

Settings in (i.e.) Index 1 of function table:

- FT-instruction 1343* = "1 - AND",
- E1 *FT-input 1 1344* = "2005 - FT-Input Buffer 5",
- E2 *FT-input 2 1345* = "2006 - FT-Input Buffer 6",
- E3 *FT-Input 3 1346* = "6 - TRUE",
- E4 *FT-input 4 1347* = "6 - TRUE",
- A1 Not-negated output 2101
Optional: *FT-target output 1 1350* = "2401 - FT-Outp. Buffer 1"
- A1 Negated Output 2201
Optional: *FT-target output 2 1351*

AND link

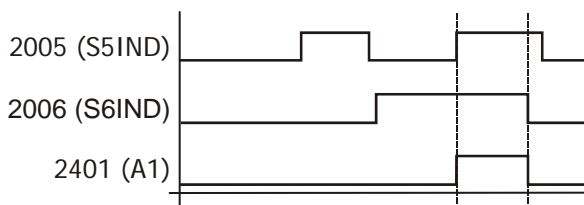
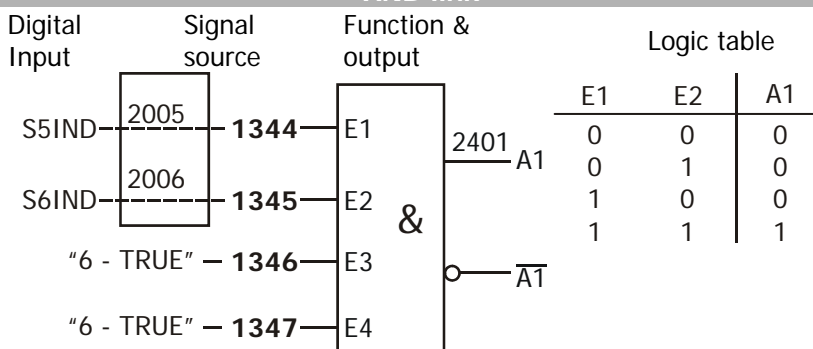

4.3.2 [2] OR link

	Par#	Type	Function		Par#	Type	Function
E1	1344	b	Input value 1	A1	1350	b	A1 = OR (E1 E2 E3 E4)
E2	1345	b	Input value 2	A2	1351	b	Inverted output A2 = A1
E3	1346	b	Input value 3	P1	1348		
E4	1347	b	Input value 4	P2	1349		

FT-instruction 1343 = "2 - OR"

Description:

The inputs are OR-linked to one another. The inputs of the instruction are the signal sources assigned (ACU functions, digital inputs). Output is TRUE if at least one input is TRUE. If all inputs are FALSE, the output will be FALSE. The output signal can be used within the function table not-negated (21xx) and negated (22xx). The output signal is available via parameter *FT-target output 1 1350*. Via parameter *FT-target output 2 1351*, the inverted output signal is available.

Note:

Unused inputs must be set to "7 - FALSE" (factory setting). For example, *FT-Input 3 1346* and *FT-input 4 1347* must be set to "7 - FALSE" if inputs *FT-input 1 1344* and *FT-input 2 1345* are to be OR-linked only.

Example:

A1 = S5IND OR S6IND

<i>FT-input buffer 1362</i>	Index 1	Index 2	Index 3	Index 4	Index 5	Index 6	...
	74-S5IND	75-S6IND	...

Settings in (i.e.) Index 3 of function table:

FT-Instruction 1343 = "2 - OR",

E1 *FT-input 1 1344* = "2005 - FT-Input Buffer 5",

E2 *FT-input 2 1345* = "2006 - FT-Input Buffer 6",

E3 *FT-Input 3 1346* = "7 - FALSE",

E4 *FT-input 4 1347* = "7 - FALSE",

A1 Not-negated output 2103

Optional: *FT-target output 1 1350* = "2401 - FT-Outp. Buffer 1"

A1 Negated Output 2203

Optional: *FT-target output 2 1351*

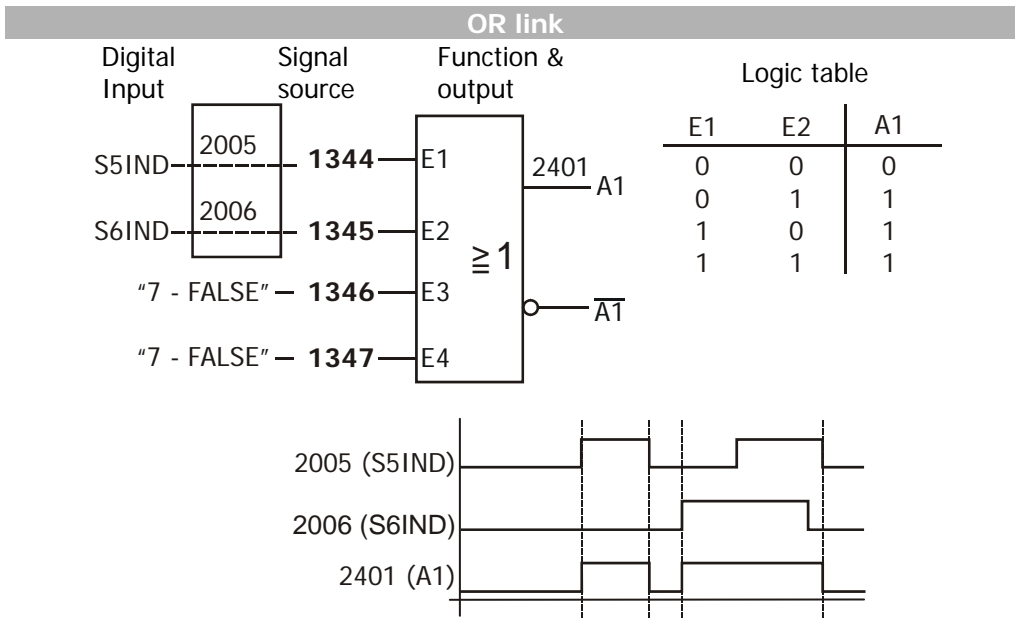

4.3.3 [3] XOR 1-link

	Par#	Type	Function		Par#	Type	Function
E1	1344	b	Input value 1	A1	1350	b	A1 = XOR1 (E1 E2 E3 E4)
E2	1345	b	Input value 2	A2	1351	b	Inverted output A2 = A1
E3	1346	b	Input value 3	P1	1348		
E4	1347	b	Input value 4	P2	1349		

FT-instruction 1343 = "3 - XOR 1"

Description:

The inputs are XOR-linked to one another. The inputs of the instruction are the signal sources assigned (ACU functions, digital inputs). Output is TRUE if exactly one input is TRUE. The output signal can be used within the function table not-negated (21xx) and negated (22xx). The output signal is available via parameter *FT-target output 1 1350*. Via parameter *FT-target output 2 1351*, the inverted output signal is available.

Example:

A1 = S5IND XOR S2IND

<i>FT-input buffer 1362</i>	Index 1	Index 2	Index 3	Index 4	Index 5	Index 6	...
	...	71-S2IND	74-S5IND

Settings in (i.e.) Index 4 of function table:

FT-instruction 1343 = "3 - XOR 1",

E1 *FT-input 1 1344* = "2005 - FT-Input Buffer 5",

E2 *FT-input 2 1345* = "2002 - FT-Input Buffer 2",

E3 *FT-Input 3 1346* = "7 - FALSE",

E4 *FT-input 4 1347* = "7 - FALSE",

A2 Not-negated output 2104

Optional: *FT-target output 1 1350* = "2402 - Outp. Buffer 2"

A2 Negated Output 2204

Optional: *FT-target output 2 1351*

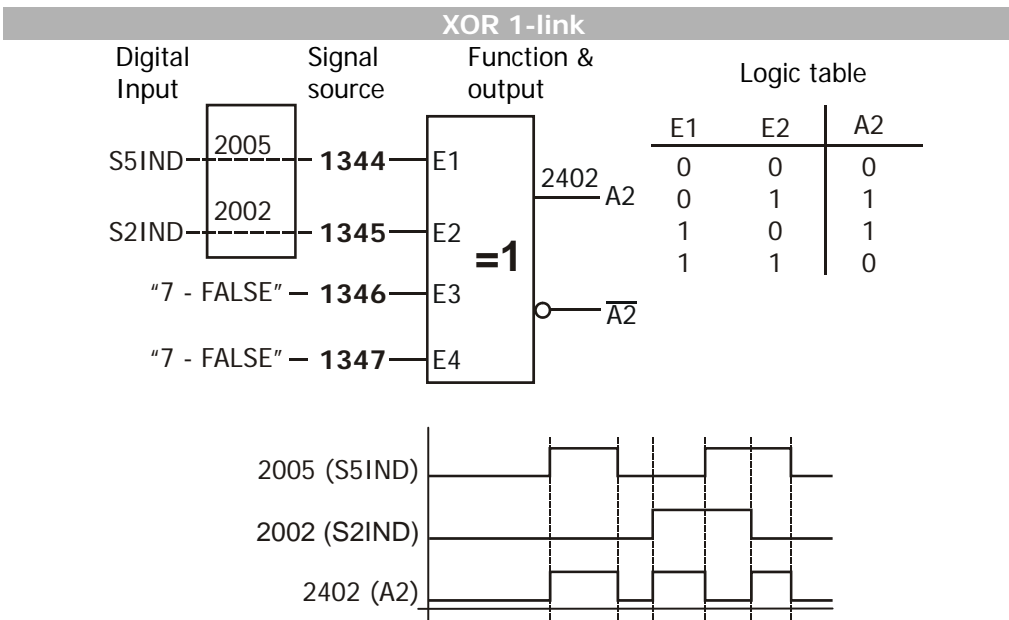

4.3.4 [4] XOR 1 || 3 link

	Par#	Type	Function		Par#	Type	Function
E1	1344	b	Input value 1	A1	1350	b	A1 = XOR3 (E1 E2 E3 E4)
E2	1345	b	Input value 2	A2	1351	b	Inverted output A2 = A1
E3	1346	b	Input value 3	P1	1348		
E4	1347	b	Input value 4	P2	1349		

FT-instruction 1343 = "4 - XOR 1||3"

Description:

The inputs are XOR-linked to one another. The inputs of the instruction are the signal sources assigned (ACU functions, digital inputs). The output is TRUE only if TRUE is present on an odd number of inputs. The output is FALSE only if TRUE is present on an even number of inputs. The output signal can be used within the function table not-negated (21xx) and negated (22xx). The output signal is available via parameter *FT-target output 1 1350*. Via parameter *FT-target output 2 1351*, the inverted output signal is available.

Example:

A1 = S3IND XOR S4IND XOR S5IND

<i>FT-input buffer 1362</i>	Index 1	Index 2	Index 3	Index 4	Index 5	Index 6	...
	72-S3IND	73-S4IND	74-S5IND

Settings in (i.e.) Index 2 of function table:

FT-instruction 1343 = "4 - XOR 1||3",

E1 *FT-input 1 1344* = "2003 – FT-Input Buffer 3",

E2 *FT-input 2 1345* = "2004 – FT-Input Buffer 4",

E3 *FT-input 3 1346* = "2005 – FT-Input Buffer 5",

E4 *FT-input 4 1347* = "7 – FALSE",

A1 Not-negated output 2102

Optional: *FT-target output 1 1350* = "2401 – FT-Outp. Buffer 1"

A1 Negated Output 2202

Optional: *FT-target output 2 1351*

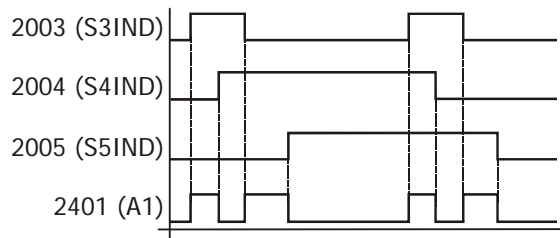
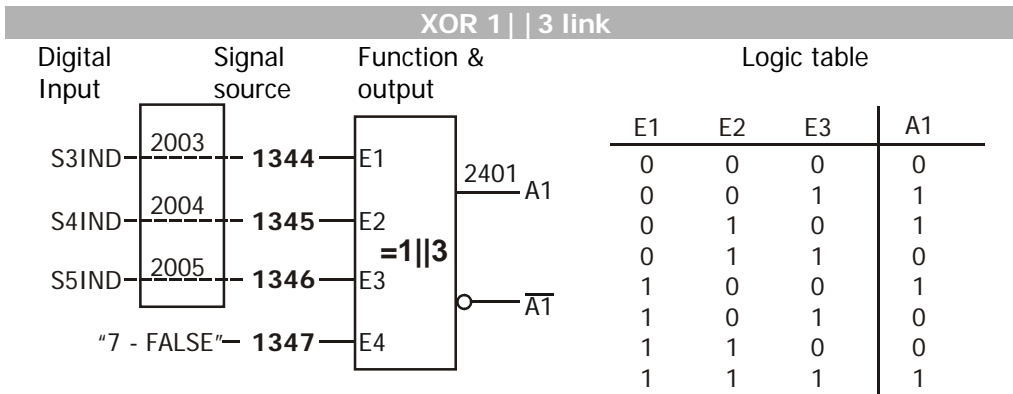

4.4 Flip-Flop types

4.4.1 [10] RS-Flip-Flop, Superior

	Par#	Type	Function		Par#	Type	Function
E1	1344	b	Set-input	A1	1350	b	Output A1
E2	1345	b	Reset-input	A2	1351	b	Inverted output A2 = A1
E3	1346	b	Superior Set-input	P1	1348		
E4	1347	b	Superior Reset-input	P2	1349		

FT-instruction 1343 = "10 - RS FlipFlop Superior"

Description:

The inputs of the instruction are the signal sources assigned in the input buffer (ACU functions, digital inputs).

TRUE on the Set input sets output on TRUE. TRUE on the Reset input sets output on FALSE. If FALSE is present on both inputs, the current status of the output signal is maintained.

TRUE on the Superior Set input sets output on TRUE. TRUE on the Superior Reset input sets output on FALSE.

Priority:

Superior Reset (highest priority)

Superior Set

Reset

Set (lowest priority)

The output signal can be used within the function table not-negated (21xx) and negated (22xx). The output signal is available via parameter *FT-target output 1* **1350**. Via parameter *FT-target output 2* **1351**, the inverted output signal is available.

Inputs Superior Set and Superior Reset are connected in series with the function. Levels at Set input E1 and Reset input E2 are processed internally. As soon as the Superior Set or Superior Reset is reset, the output is switched to the internally saved value.

Example:

RS-Flip-Flop with Set=S2IND, Reset=S3IND, Sup.Set=S4IND, Sup.Reset=MF11D

<i>FT-input buffer</i> 1362	Index 1	Index 2	Index 3	Index 4	Index 5	Index 6	Index 7	...
	...	71-S2IND	72-S3IND	73-S4IND	76-MF11D	...

Settings in (i.e.) Index 2 of function table:

- FT-instruction* **1343** = "10 - RS FlipFlop Superior",
- S *FT-input 1* **1344** = "2002 – FT-Input Buffer 2",
- R *FT-input 2* **1345** = "2003 – FT-Input Buffer 3",
- SS *FT-input 3* **1346** = "2004 – FT-Input Buffer 4",
- SR *FT-input 4* **1347** = "2007 – FT-Input Buffer 7",
- A1 Not-negated output 2102
Optional: *FT-target output 1* **1350** = "2401 – FT-Outp. Buffer 1"
- A1 Negated Output 2202
Optional: *FT-target output 2* **1351**

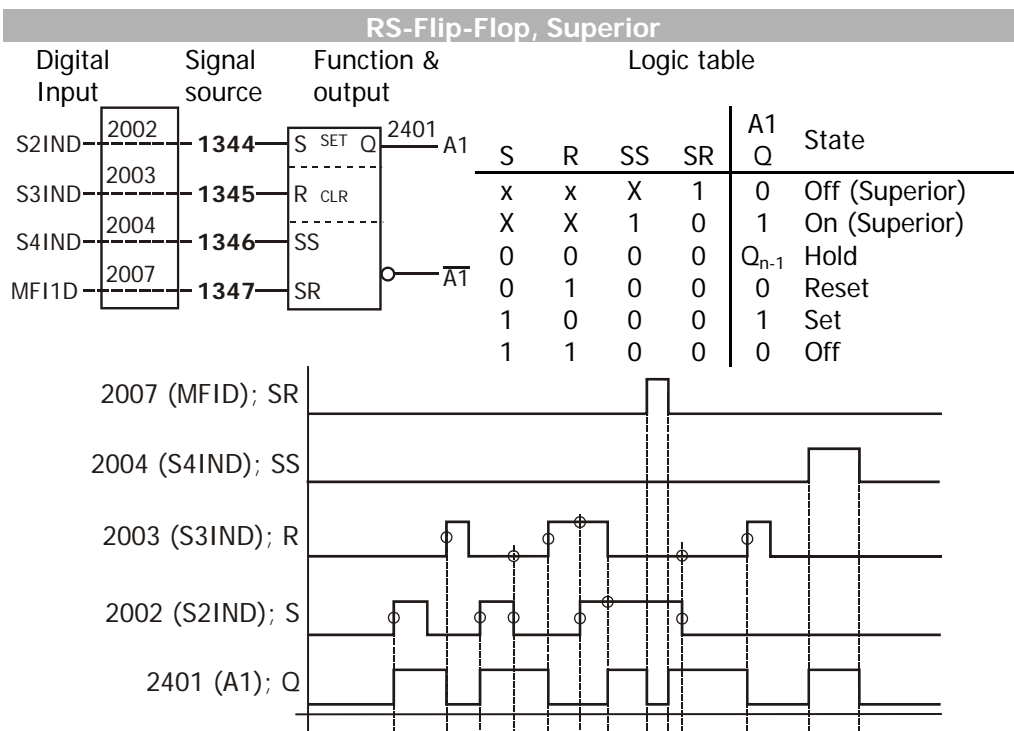

- Set: If S-input {parameter *FT-input 1* **1344**} is TRUE, output 2401 is set to TRUE.
- Save: If all inputs are FALSE, the output remains unchanged.
- Reset: If R input becomes TRUE, the output is set to FALSE.
- Off: If both inputs are set to TRUE, the output is FALSE.
- Superior-Set: SS, set output to TRUE.
- Superior-Reset: SR, set output to FALSE (CLR).

4.4.2 [110] RS-Flip-Flop, Master

	Par#	Type	Function		Par#	Type	Function
E1	1344	b	Set-input	A1	1350	b	Output A1
E2	1345	b	Reset-input	A2	1351	b	Inverted output A2 = A1
E3	1346	b	Master Set-input	P1	1348		
E4	1347	b	Master Reset-input	P2	1349		

FT-instruction 1343 = "110 - RS FlipFlop Master"

Description:

The inputs of the instruction are the signal sources assigned (ACU functions, digital inputs).

TRUE on the Set input sets output on TRUE. TRUE on the Reset input sets output on FALSE. If FALSE is present on both inputs, the current status of the output signal is maintained. TRUE on the Master Set input sets output on TRUE. TRUE on the Superior Reset input sets output on FALSE.

Priority:

Master Reset (highest priority)

Master Set

Reset

Set (lowest priority)

The output signal can be used within the function table not-negated (21xx) and negated (22xx). The output signal is available via parameter *FT-target output 1 1350*. Via parameter *FT-target output 2 1351*, the inverted output signal is available.

Master Set and Master Reset are connected parallel with the function and change the state of the function as soon as the signal is present.

Example:

RS-Flip-Flop with Set=S2IND, Reset=S3IND, Master Set=S4IND, MasterReset=MFI1D

<i>FT-input</i>	Index 1	Index 2	Index 3	Index 4	Index 5	Index 6	Index 7	...
<i>buffer 1362</i>	...	71-S2IND	72-S3IND	73-S4IND	76-MFI1D	...

Settings in (i.e.) Index 10 of function table:

FT-instruction 1343 = "110 - RS FlipFlop Master",

S *FT-input 1 1344* = "2002 – FT-Input Buffer 2",

R *FT-input 2 1345* = "2003 – FT-Input Buffer 3",

MS *FT-input 3 1346* = "2004 – FT-Input Buffer 4",

MR *FT-input 4 1347* = "2007 – FT-Input Buffer 7",

A1 Not-negated output 2110

Optional: *FT-target output 1 1350* = "2401 – FT-Outp. Buffer 1"

A1 Negated Output 2210

Optional: *FT-target output 2 1351*

RS-Flip-Flop, Master

Digital Input	Signal source	Function & output	Logic table				A1	State
S2IND	2002	S SET	S	R	MS	MR	Q	Off (Master)
S3IND	2003	R CLR	x	x	X	1	0	On (Master)
S4IND	2004	MS	X	X	1	0	1	Hold
MF11D	2007	MR	0	0	0	0	0	Reset
			0	1	0	0	0	Set
			1	0	0	0	1	Off
			1	1	0	0	0	

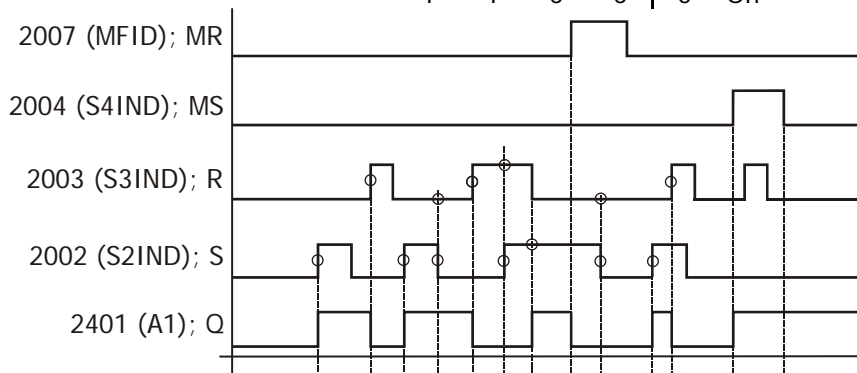

- Set: If S-input {parameter *FT-input 1 1344*} is TRUE, the output is set to TRUE.
- Save: If all inputs are FALSE, the output remains unchanged.
- Reset: If R input becomes TRUE, the output is set to FALSE.
- Off: If both inputs are set to TRUE, the output is FALSE.
- Master-Set: MS, set output to TRUE.
- Master-Reset: MR, set output to FALSE (CLR).

4.4.3 [20] Toggle-Flip-Flop, Superior

	Par#	Type	Function		Par#	Type	Function
E1	1344	b	Toggle 1	A1	1350	b	Output A1
E2	1345	b	Toggle 2	A2	1351	b	Inverted output A2 = A1
E3	1346	b	Superior Set-input	P1	1348		
E4	1347	b	Superior Reset-input	P2	1349		

FT-instruction 1343 = "20 - Toggle FlipFlop Superior"

Description:

The output signal changes with positive clock edge T1 at input 1 or with negative clock edge T2 at input 2.

TRUE at Superior-Set input sets output TRUE. TRUE at Superior-Reset input sets output FALSE.

The output signal can be used within the function table not-negated (21xx) and negated (22xx). The output signal is available via parameter *FT-target output 1 1350*. Via parameter *FT-target output 2 1351*, the inverted output signal is available.

Inputs Superior Set and Superior Reset are connected in series with the function. Levels on T1-input E1 and T2 input E2 are processed internally. As soon as the Superior Set or Superior Reset is reset, the output is switched to the internally saved value.

Example:

Toggle-Flip-Flop with T1=S2IND, T3=S3IND, Sup.Set=S4IND, Sup.Reset=MF11D

<i>FT-input buffer 1362</i>	Index 1	Index 2	Index 3	Index 4	Index 5	Index 6	Index 7	...
	...	71-S2IND	72-S3IND	73-S4IND	76-MF11D	...

Settings in (i.e.) Index 2 of function table:

- FT-instruction* **1343** = "20 - Toggle FlipFlop Superior",
- T1 *FT-input 1* **1344** = "2002 – FT-Input Buffer 2",
- T2 *FT-input 2* **1345** = "2003 – FT-Input Buffer 3",
- SS *FT-input 3* **1346** = "2004 – FT-Input Buffer 4",
- SR *FT-input 4* **1347** = "2007 – FT-Input Buffer 7",
- A1 Not-negated output 2102
- Optional: *FT-target output 1* **1350** = "2401 – FT-Outp. Buffer 1"
- A1 Negated Output 2202
- Optional: *FT-target output 2* **1351**

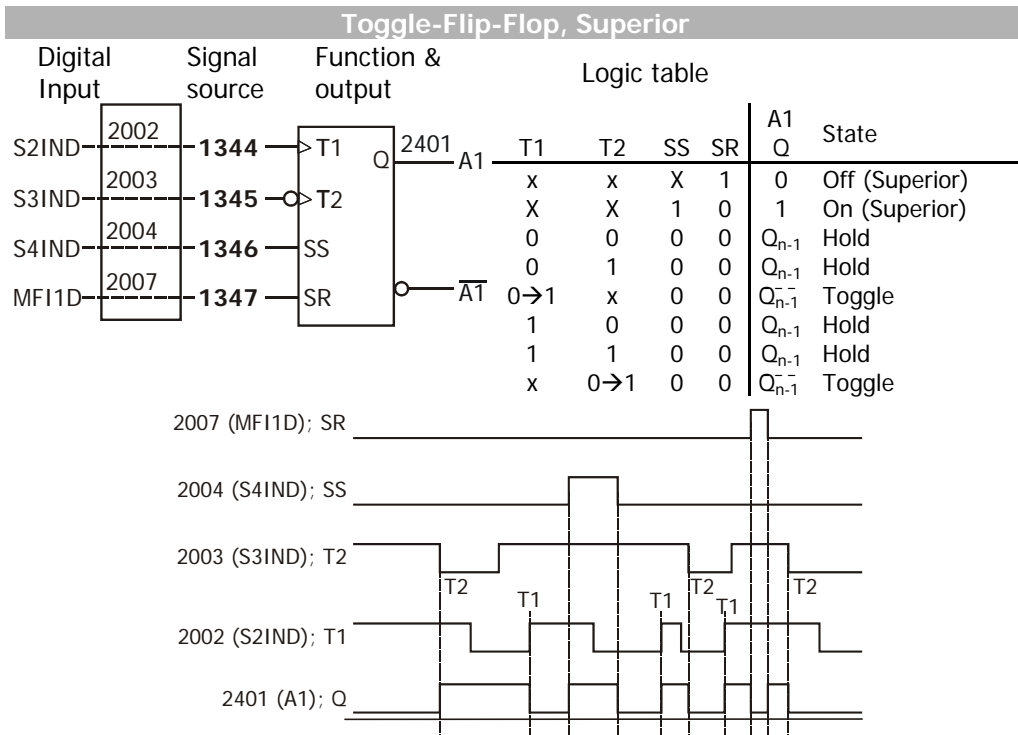

4.4.4 [120] Toggle-Flip-Flop, Master

	Par#	Type	Function		Par#	Type	Function
E1	1344	b	Toggle 1	A1	1350	b	Output A1
E2	1345	b	Toggle 2	A2	1351	b	Inverted output A2 = A1
E3	1346	b	Master Set-input	P1	1348		
E4	1347	b	Master Reset-input	P2	1349		

FT-instruction **1343** = "120 - Toggle FlipFlop Master"

Description:

The output signal changes with positive clock edge T1 at input 1 or with negative clock edge T2 at input 2.

TRUE at Master-Set input sets output TRUE. TRUE at Master-Reset input sets output FALSE.

The output signal can be used within the function table not-negated (21xx) and negated (22xx). The output signal is available via parameter *FT-target output 1* **1350**. Via parameter *FT-target output 2* **1351**, the inverted output signal is available.

Master Set and Master Reset are connected parallel with the function and change the state of the function as soon as the signal is present.

Example:

Toggle-Flip-Flop with T1=S2IND, T3=S3IND, MasterSet=S4IND, MasterReset=MF11D

<i>FT-input</i> <i>buffer 1362</i>	Index 1	Index 2	Index 3	Index 4	Index 5	Index 6	Index 7	...
	...	71-S2IND	72-S3IND	73-S4IND	76-MF11D	...

Settings in (i.e.) Index 12 of function table:

FT-instruction 1343 = "120 - Toggle FlipFlop Master",T1 *FT-input 1 1344* = "2002 – FT-Input buffer 2",T2 *FT-input 2 1345* = "2003 – FT-Input buffer 3",MS *FT-input 3 1346* = "2004 – FT-Input buffer 4",MR *FT-input 4 1347* = "2007 – FT-Input buffer 7",

A1 Not-negated output 2112

Optional: *FT-target output 1 1350* = "2401 – FT-Outp. Buffer 1"

A1 Negated Output 2212

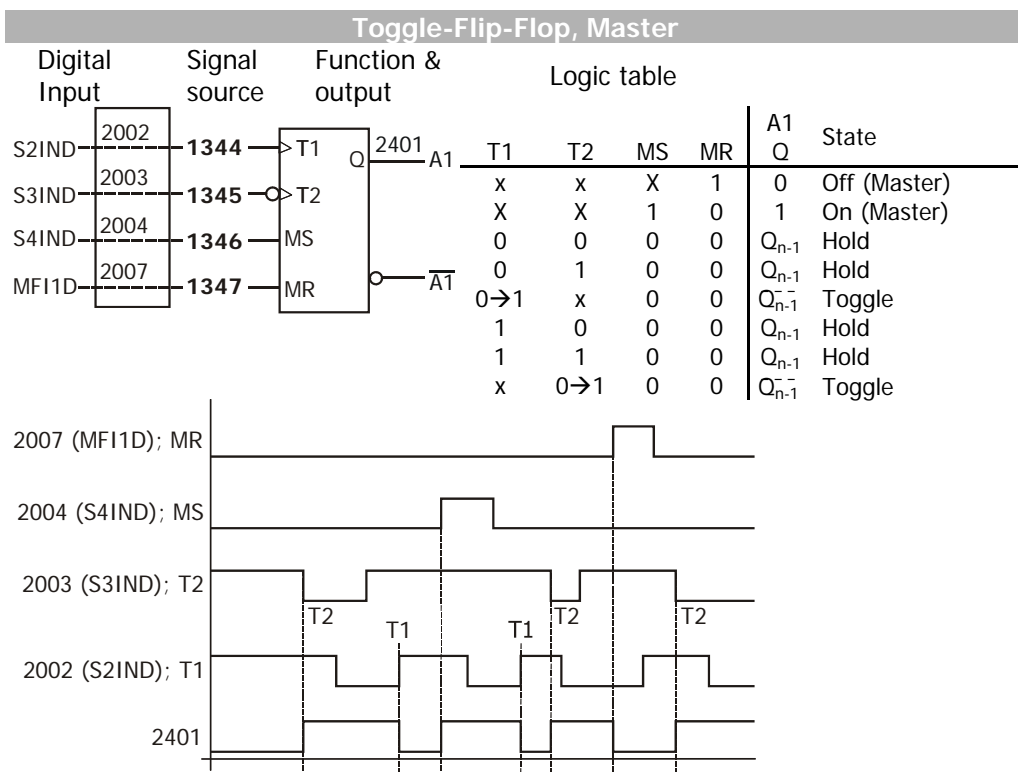
Optional: *FT-target output 2 1351***4.4.5 [30] D-Flip-Flop, Superior**

	Par#	Type	Function		Par#	Type	Function
E1	1344	b	C, clock	A1	1350	b	Output A1
E2	1345	b	D, data input	A2	1351	b	Inverted output A2 = A1
E3	1346	b	Superior Set-input	P1	1348		
E4	1347	b	Superior Reset-input	P2	1349		

FT-instruction 1343 = "30 - D FlipFlop Superior"**Description:**

If a positive edge is received at input 1 (clock pulse input C, Clock) the signal present at input 2 (data input D) is transferred to the output.

TRUE at Superior-Set input sets output TRUE. TRUE at Superior-Reset input sets output FALSE.

The output signal can be used within the function table not-negated (21xx) and negated (22xx). The output signal is available via parameter *FT-target output 1 1350*. Via parameter *FT-target output 2 1351*, the inverted output signal is available.

Inputs Superior Set and Superior Reset are connected in series with the function. Levels on C input E1 and D input E2 are processed internally. As soon as the Superior Set or Superior Reset is reset, the output is switched to the internally saved value.

Example:

D-Flip-Flop with C=S5IND, D=S6IND, Sup.Set=S4IND, Sup.Reset=MF11D

<i>FT-input buffer 1362</i>	Index 1	Index 2	Index 3	Index 4	Index 5	Index 6	Index 7	...
	73-S4IND	74-S5IND	75-S6IND	76-MF11D	...

Settings in (i.e.) Index 21 of function table:

- FT-instruction 1343* = "30 - D FlipFlop Superior",
- C *FT-input 1 1344* = "2005 – FT-Input Bbuffer 5",
- D *FT-input 2 1345* = "2006 – FT-Input Buffer 6",
- SS *FT-input 3 1346* = "2004 – FT-Input Buffer 4",
- SR *FT-input 4 1347* = "2007 – FT-Input Buffer 7",
- A1 Not-negated output 2121
Optional: *FT-target output 1 1350* = "2401 – FT-Outp. Buffer 1"
- A1 Negated Output 2221
Optional: *FT-target output 2 1351*

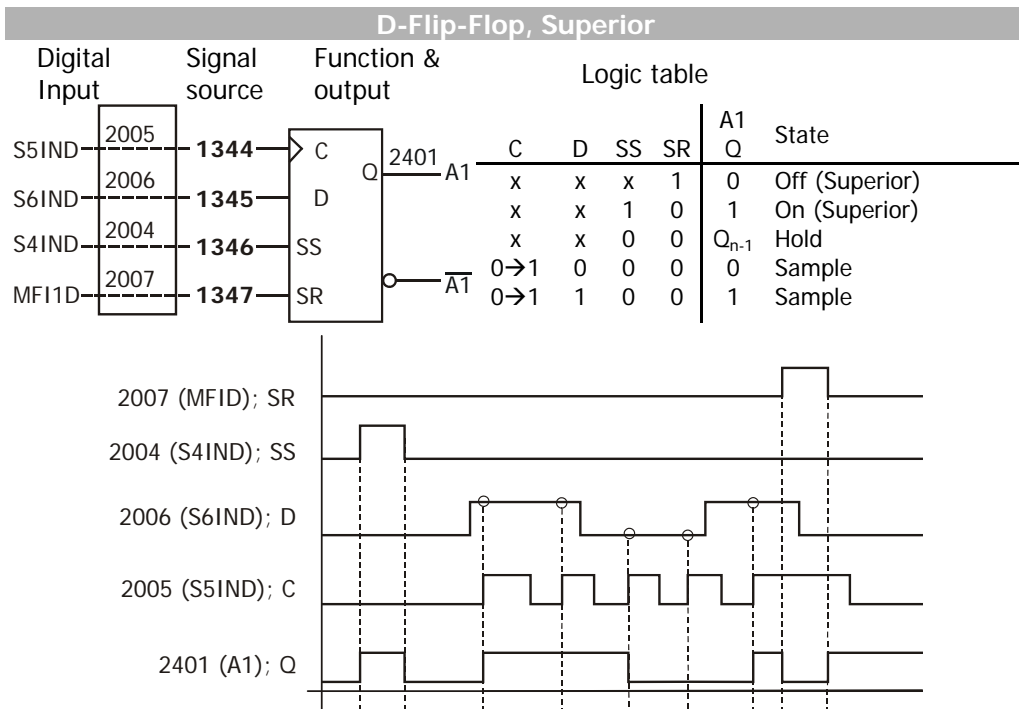

4.4.6 [130] D-Flip-Flop, Master

	Par#	Type	Function		Par#	Type	Function
E1	1344	b	C, clock	A1	1350	b	Output A1
E2	1345	b	D, data input	A2	1351	b	Inverted output A2 = A1
E3	1346	b	Master Set-input	P1	1348		
E4	1347	b	Master Reset-input	P2	1349		

FT-instruction 1343 = "130 - D FlipFlop Master"

Description:

If a positive edge is received at input 1 (clock pulse input C, Clock) the signal present at input 2 (data input D) is transferred to the output.

TRUE at Superior-Set input sets output TRUE. TRUE at Superior-Reset input sets output FALSE.

The output signal can be used within the function table not-negated (21xx) and negated (22xx). The output signal is available via parameter *FT-target output 1* **1350**. Via parameter *FT-target output 2* **1351**, the inverted output signal is available.

Master Set and Master Reset are connected parallel with the function and change the state of the function as soon as the signal is present.

Example:

D-Flip-Flop with C=S5IND, D=S6IND, MasterSet=S4IND, MasterReset=MF11D

<i>FT-input buffer</i> 1362	Index 1	Index 2	Index 3	Index 4	Index 5	Index 6	Index 7	...
	73-S4IND	74-S5IND	75-S6IND	76-MF11D	...

Settings in (i.e.) Index 5 of function table:

FT-instruction **1343** = "130 - D FlipFlop Master",

C *FT-input 1* **1344** = "2002 – FT-Input Buffer 5",

D *FT-input 2* **1345** = "2003 – FT-Input Buffer 6",

MS *FT-input 3* **1346** = "2004 – FT-Input Buffer 4",

MR *FT-input 4* **1347** = "2007 – FT-Input Buffer 7",

A1 Not-negated output 2105

Optional: *FT-target output 1* **1350** = "2401 – FT-Outp. Buffer 1"

A1 Negated Output 2205

Optional: *FT-target output 2* **1351**

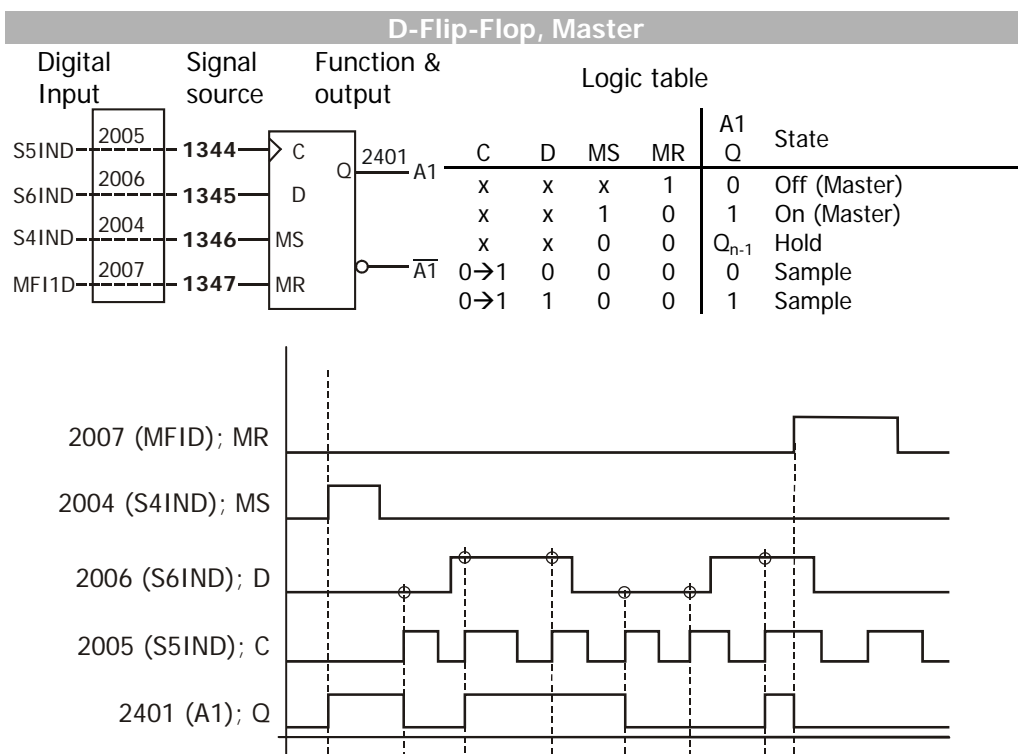

4.5 Delay

The delay can be used to delay the edges for a specified time. For the rising and the falling edge two separate timers are available.

If delay times differ in their length, this can result, that an edge F1 at the time T_{11} can have a later switching time T_{12} than the edge F2 at the time T_{21} with a switching time T_{22} . In this case no edge is switched at the output, because else it could happen, that input and output are inverted to each other.

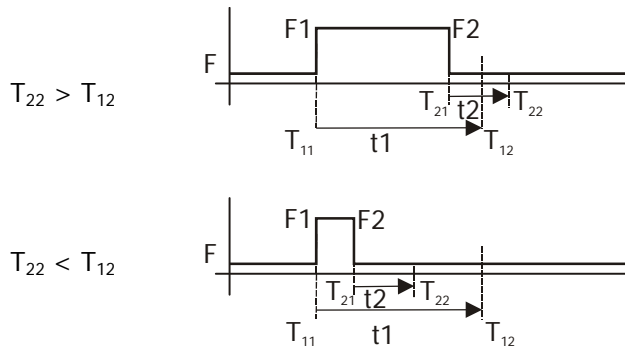

The delays are implemented as „retriggerable“ and „not retriggerable“ version.

Retriggerable means, that an anew (same oriented) edge during the processing of the delay will start the delay again with a new calculated switching time for the edge (“last edge dominant”). The level of input and output is not used for the calculation of the switching times.

“Retriggerable” is the suitable choice, when several signals in short succession occur, from which only the last one should be processed or a continuous signal, where short pulse faults (“flicker”) can occur, which have to be filtered out. The level of input and output is not used for the calculation of the switching times.

Not retriggerable means, that an anew (same oriented) edge during the processing of the delay is not started again, the original switching time is preserved (“first edge dominant”).

Not retriggerable is suited, when an edge should start a process, which operation is not to be interrupted until the delay is finished.

Note:

The unit of the selected times is either millisecond [ms], second [s] or minute [min]. Internally the values are limited to 24 days.

Example 1

1 square pulse

Switching on time input (F): 500 ms
 Delay time positive edge: 1000 ms
 Delay time negative edge: 800 ms

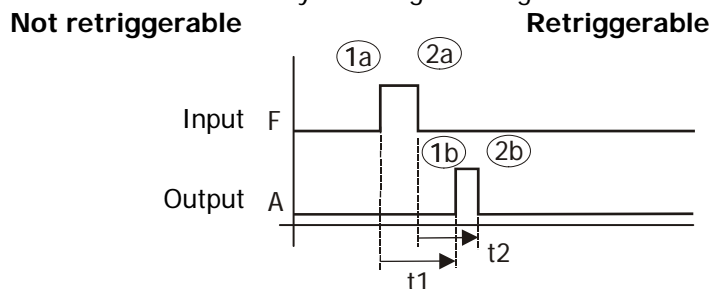

Edge 1a starts timer t1
 Edge 2a starts timer t2
 Edge 1b is output by t1 delayed (relating to 1a)
 Edge 2b is output by t2 delayed (relating to 2a)

Example 2

1 square pulse and following positive edge

Switching on time input (F): 500 ms
 Switching off time input (F): 350 ms
 Delay time positive edge: 1000 ms (t1)
 Delay time negative edge: 800 ms (t2)

Not retriggerable

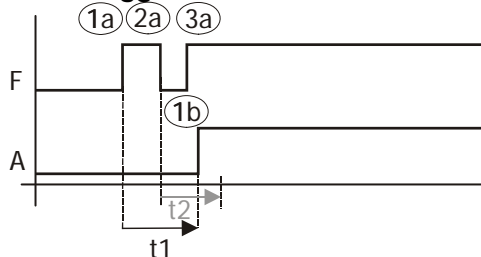

1a starts timer t1
 2a starts timer t2
 1b is output by t1 delayed
 3a (continuous signal) interrupts the execution of 2a

Retriggerable

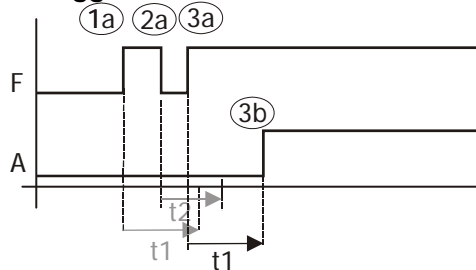

1a starts timer t1
 2a starts timer t2
 3a starts timer t1 anew (retrigger)
 3b is output by t1 delayed (relating to 3a)

Example 3

4 square pulses in succession

Switching times and delay times like in example 2

Not retriggerable

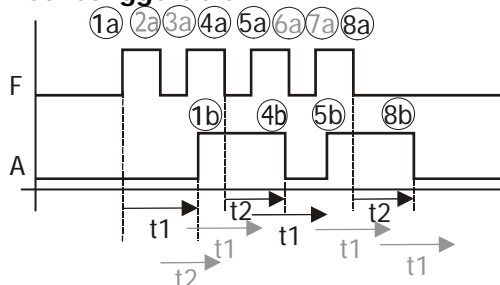

1a starts timer t1
 2a starts timer t2
 3a interrupts the execution of 2a
 1b is output with t1 delayed
 4a starts timer t2
 5a starts timer t1
 4b is output with t1 delayed
 5a to 8b: Repetition from 2a

Retriggerable

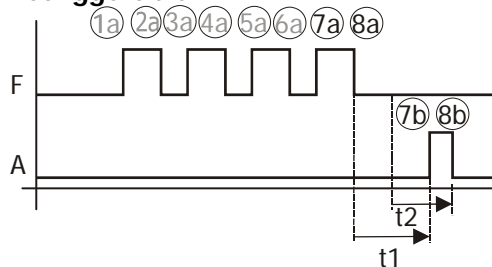

1a starts Timer t1
 2a starts Timer t2
 3a starts Timer t1 anew (retrigger)
 4a starts Timer t2 anew (retrigger)
 5a...6a starts Timer t1 and t2 anew
 7b is output by t1 (relating to 7a)
 8b is output by t2 (relating to 8a)

Example 4

3 square pulses in succession and following positive edge

Switching times and delay times like in example 2

Not retriggerable

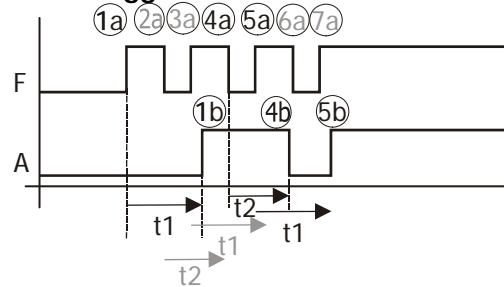

Processing like example 3. The positive edge 5a sets a high output. 6a and 7a follow in quick succession, so that these two edges are filtered out.

Retriggerable

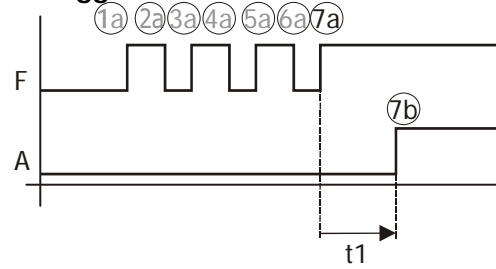

Processing like example 3. The last positive edge 7a sets a high output.

4.5.1 [40,41,42] Delay (retriggerable), Superior

	Par#	Type	Function
E1	1344	b	F, edge
E2	1345		
E3	1346	b	Superior Set-input
E4	1347	b	Superior Reset-input

	Par#	Type	Function
A1	1350	b	Output A1
A2	1351	b	Inverted output A2 = A1
P1	1348	t	On delay t1
P2	1349	t	Off delay t2

FT-instruction 1343 = 40 [ms], 41 [s] or 42 [min] - "Delay Superior (retriggerable)"

Description:

The positive edge at Input 1 is delayed by t1 (*FT-parameter 1 1348*), the negative edge is delayed by t2 (*FT-parameter 2 1349*) before switching them through to the output. The delay time starts again with each edge.

TRUE at Superior-Set input sets output TRUE. TRUE at Superior-Reset input sets output FALSE.

The output signal can be used within the function table not-negated (21xx) and negated (22xx). The output signal is available via parameter *FT-target output 1 1350*. Via parameter *FT-target output 2 1351*, the inverted output signal is available.

Inputs Superior Set and Superior Reset are connected in series with the function. Levels at Input E1 are processed internally. As soon as the Superior Set or Superior Reset is reset, the output is switched to the internally saved value.

Example:

The edge of S2IND shall be delayed by 400 ms/800 ms.

<i>FT-input buffer 1362</i>	Index 1	Index 2	Index 3	Index 4	Index 5	Index 6	...
	70-Inverter Release	71-S2IND	72-S3IND	73-S4IND	74-S5IND

Settings in (i.e.) Index 8 of function table:

- FT-instruction 1343* = "40 – Delay Superior ms (retriggerable)",
- F *FT-input 1 1344* = "2005 – FT-Input Buffer 5",
- SS *FT-input 3 1346* = "2004 – FT-Input Buffer 4",
- SR *FT-input 4 1347* = "2002 – FT-Input Buffer 2",
- P1 *FT-parameter 1 1348* = 400
- P2 *FT-parameter 2 1349* = 800
- A1 Not-negated output 2108
- Optional: *FT-target output 1 1350* = "2401 - FT-Outp. Buffer 1"
- A1 Negated output 2208
- Optional: *FT-target output 2 1351*

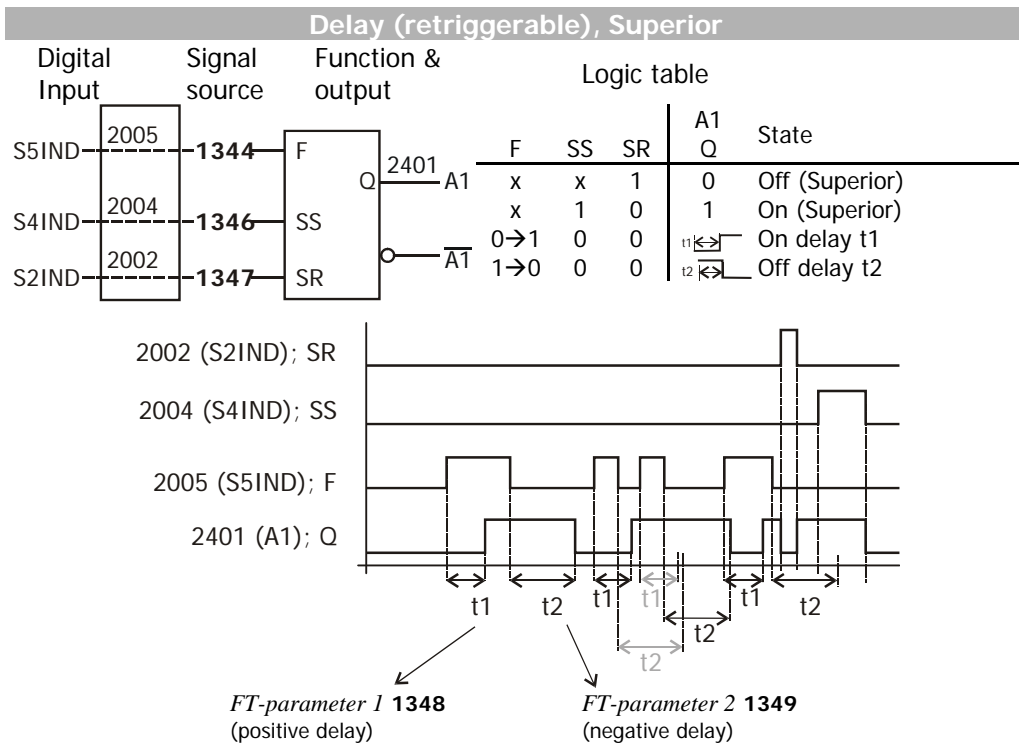

4.5.2 [140,141,142] Delay (retriggerable), Master

Par#	Type	Function	Par#	Type	Function		
E1	1344	b	F, edge	A1	1350	b	Output A1
E2	1345			A2	1351	b	Inverted output A2 = A1
E3	1346	b	Master Set-input	P1	1348	t	On delay t1
E4	1347	b	Master Reset-input	P2	1349	t	Off delay t2

FT-instruction 1343 = 140 [ms], 141 [s] or 142 [min] - "Delay Master (retriggerable)"

Description:

The positive edge at Input 1 is delayed by t1 (*FT-parameter 1 1348*), the negative edge is delayed by t2 (*FT-parameter 2 1349*) before switching them through to the output. The delay time starts again with each edge.

TRUE at Master-Set input sets output TRUE. TRUE at Master-Reset input sets output FALSE.

The output signal can be used within the function table not-negated (21xx) and negated (22xx). The output signal is available via parameter *FT-target output 1 1350*. Via parameter *FT-target output 2 1351*, the inverted output signal is available.

Master Set and Master Reset are connected parallel with the function and change the state of the function as soon as the signal is present.

Example:

The edge of S2IND shall be delayed by 9 s/18 s.

<i>FT-input buffer 1362</i>	Index 1	Index 2	Index 3	Index 4	Index 5	Index 6	...
	70-Inverter Release	71-S2IND	72-S3IND	73-S4IND	74-S5IND

Settings in (i.e.) Index 14 of function table:

- FT-instruction 1343* = "141 - Delay Master s (retriggerable)",
- F *FT-input 1 1344* = "2005 – FT-Input Buffer 5",
- MS *FT-input 3 1346* = "2004 – FT-Input Buffer 4",
- MR *FT-input 4 1347* = "2002 – FT-Input Buffer 2",
- P1 *FT-parameter 1 1348* = 9
- P2 *FT-parameter 2 1349* = 18
- A1 Not-negated output 2114
Optional: *FT-target output 1 1350* = „2401 - FT-Outp. Buffer 1“
- A1 Negated output 2214
Optional: *FT-target output 2 1351*

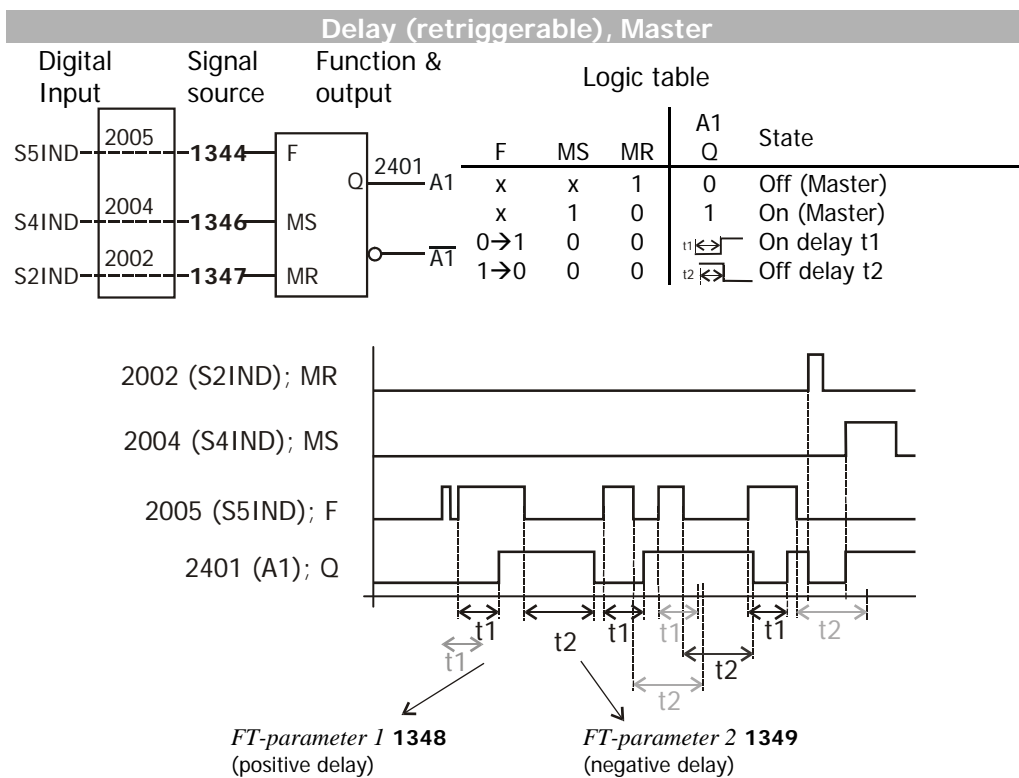

4.5.3 [50,51,52] Delay (not retriggerable), Superior

Par#	Type	Function	Par#	Type	Function		
E1	1344	b	F, edge	A1	1350	b	Output A1
E2	1345			A2	1351	b	Inverted output A2 = A1
E3	1346	b	Superior Set-input	P1	1348	t	On delay t1
E4	1347	b	Superior Reset-input	P2	1349	t	Off delay t2

FT-instruction 1343 = 50 [ms], 51 [s] or 52 [min] - "Delay Superior (not retriggerable)"

Description:

The positive edge at Input 1 is delayed by t1 (*FT-parameter 1 1348*), the negative edge is delayed by t2 (*FT-parameter 2 1349*) before switching them through to the output. The delay time starts again with each edge.

TRUE at Master-Set input sets output TRUE. TRUE at Master-Reset input sets output FALSE.

The output signal can be used within the function table not-negated (21xx) and negated (22xx). The output signal is available via parameter *FT-target output 1 1350*. Via parameter *FT-target output 2 1351*, the inverted output signal is available.

Inputs Superior Set and Superior Reset are connected in series with the function. Levels at input E1 are processed internally. As soon as the Superior Set or Superior Reset is reset, the output is switched to the internally saved value.

Example:

The edge of S2IND shall be delayed by 100 ms/200 ms.

<i>FT-input buffer 1362</i>	Index 1	Index 2	Index 3	Index 4	Index 5	Index 6	...
	70-Inverter Release	71-S2IND	72-S3IND	73-S4IND	74-S5IND

Settings in (i.e.) Index 17 of function table:

- FT-instruction 1343* = "50 – Delay Superior ms (not retriggerable)",
- F *FT-input 1 1344* = "2005 – FT-Input Buffer 5",
- SS *FT-input 3 1346* = "2004 – FT-Input Buffer 4",
- SR *FT-input 4 1347* = "2002 – FT-Input Buffer 2",
- P1 *FT-parameter 1 1348* = 100
- P2 *FT-parameter 2 1349* = 200
- A1 Not-negated output 2117
Optional: *FT-target output 1 1350* = "2401 – FT-Outp. Buffer 1"
- A1 Negated output 2217
Optional: *FT-target output 2 1351*

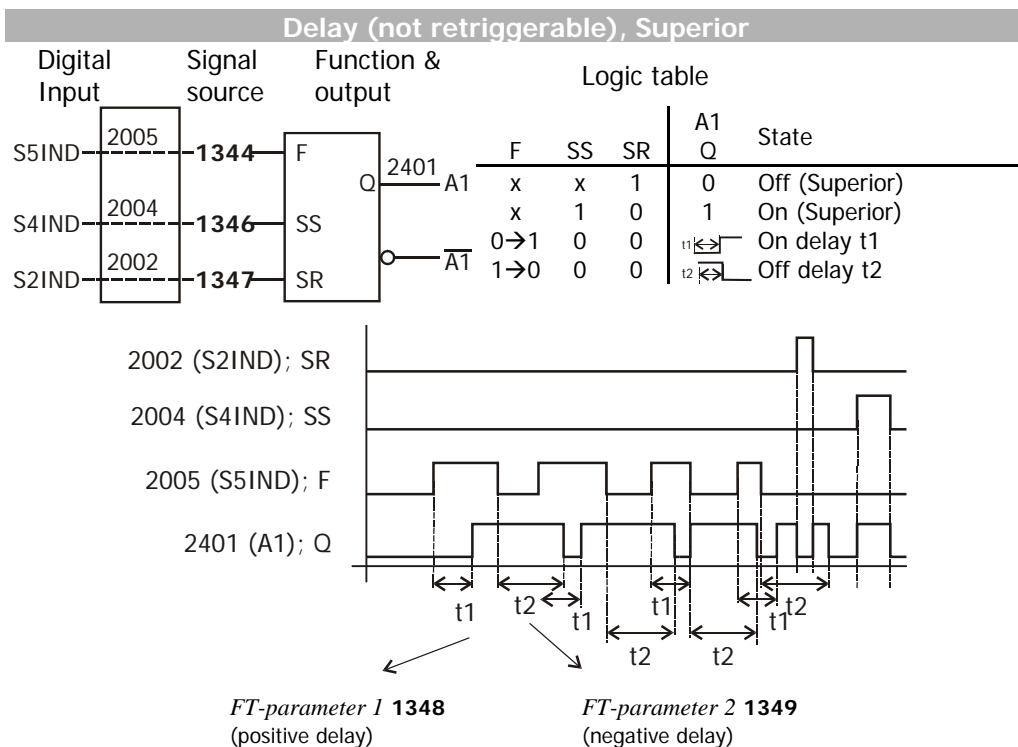

4.5.4 [150,151,152] Delay (not retriggerable), Master

	Par#	Type	Function		Par#	Type	Function
E1	1344	b	F, edge	A1	1350	b	Output A1
E2	1345			A2	1351	b	Inverted output A2 = A1
E3	1346	b	Master Set-input	P1	1348	t	On delay t1
E4	1347	b	Master Reset-input	P2	1349	t	Off delay t2

FT-instruction 1343 = 150 [ms], 151 [s] or 152 [min] – "Delay Master (not retriggerable)"

Description:

The positive edge at Input 1 is delayed by t_1 (*FT-parameter 1 1348*), the negative edge is delayed by t_2 (*FT-parameter 2 1349*) before switching them through to the output. The delay time starts again with each edge.

TRUE at Master-Set input sets output TRUE. TRUE at Master-Reset input sets output FALSE.

The output signal can be used within the function table not-negated (21xx) and negated (22xx). The output signal is available via parameter *FT-target output 1 1350*. Via parameter *FT-target output 2 1351*, the inverted output signal is available.

Master Set and Master Reset are connected parallel with the function and change the state of the function as soon as the signal is present.

Example:

The edge of S2IND shall be delayed by 100 ms/50 ms.

<i>FT-input buffer 1362</i>	Index 1 70-Inverter Release	Index 2 71-S2IND	Index 3 72-S3IND	Index 4 73-S4IND	Index 5 74-S5IND	Index 6
-----------------------------	--------------------------------	---------------------	---------------------	---------------------	---------------------	----------------	-----

Settings in (i.e.) Index 14 of function table:

- FT-instruction 1343* = "150 - Delay Master ms (not retriggerable)",
- F *FT-input 1 1344* = "2005 – FT-Input Buffer 5",
- MS *FT-input 3 1346* = "2004 – FT-Input Buffer 4",
- MR *FT-input 4 1347* = "2002 – FT-Input Buffer 2",
- P1 *FT-parameter 1 1348* = 100
- P2 *FT-parameter 2 1349* = 50
- A1 Not-negated output 2114
Optional: *FT-target output 1 1350* = "2401 - FT-Outp. Buffer 1"
- A1 Negated output 2214
Optional: *FT-target output 2 1351*

Delay (not retriggerable), Master

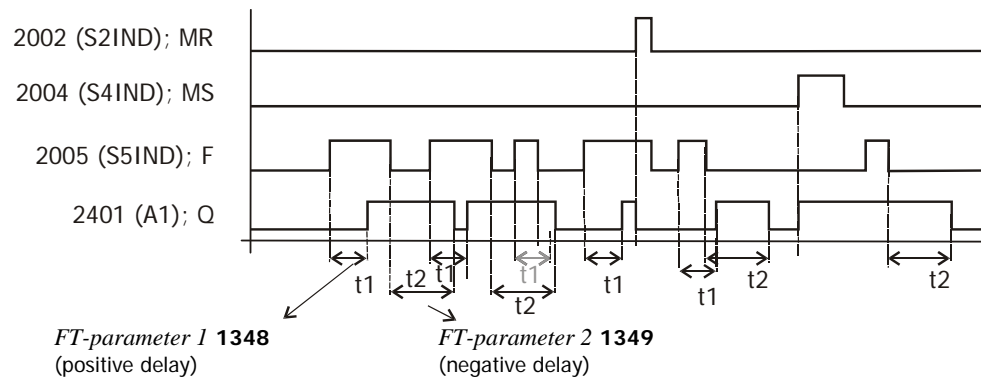
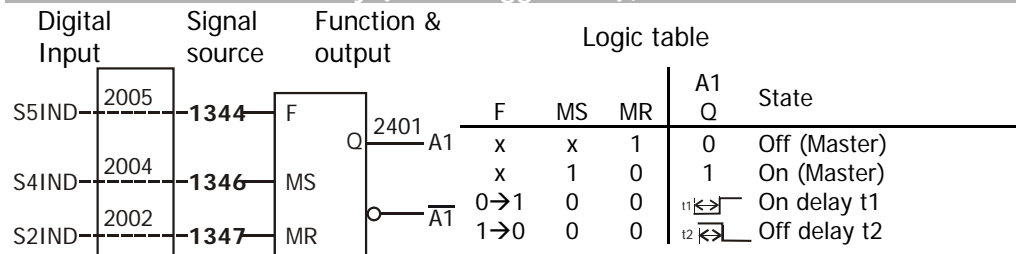

4.6 Timer functions

4.6.1 [60,61,62] Monoflop (retriggerable), Superior

	Par#	Type	Function		Par#	Type	Function
E1	1344	b	M, Monoflop-edge 1	A1	1350	b	Output A1
E2	1345	b	M, Monoflop-edge 2	A2	1351	b	Inverted output A2 = A1
E3	1346	b	Superior Set-input	P1	1348	t	On-Time (High)
E4	1347	b	Superior Reset-input	P2	1349	t	Ignore-Edge-Time

FT-instruction **1343** = 60 [ms], 61 [s] or 62 [min] – “Monoflop Superior (retriggerable)”

Description:

The output signal becomes TRUE with the positive edge of input 1 or the negative edge of input 2. The time set in *FT-parameter 1* **1348** is the On-Time (High) and the time set in *FT-parameter 2* **1349** is the Ignore-Edge-Time (Low). The delay time starts again with each edge. TRUE at Superior-Set input sets output TRUE. TRUE at Superior-Reset input sets output FALSE.

The output signal can be used within the function table not-negated (21xx) and negated (22xx). The output signal is available via parameter *FT-target output 1* **1350**. Via parameter *FT-target output 2* **1351**, the inverted output signal is available.

Inputs Superior Set and Superior Reset are connected in series with the function. Levels on Monoflop inputs E1 and E2 are processed internally. As soon as the Superior Set or Superior Reset is reset, the output is switched to the internally saved value.

Example:

The positive edge of S5IND or the negative edge of S6IND shall switch on the output for 200 ms. The “Out”-Time is 900 ms.

<i>FT-input buffer</i> 1362	Index 1	Index 2	Index 3	Index 4	Index 5	Index 6	Index 7	...
	73-S4IND	74-S5IND	75-S6IND	76-MF1D	...

Settings in (i.e.) Index 5 of function table:

- FT-instruction* **1343** = “60 – Monoflop Superior ms (retriggerable)”,
- M *FT-input 1* **1344** = “2005 – FT-Input Buffer 5”,
- M *FT-input 2* **1345** = “2006 – FT-Input Buffer 6”,
- SS *FT-input 3* **1346** = “2004 – FT-Input Buffer 4”,
- SR *FT-input 4* **1347** = “2007 – FT-Input Buffer 7”,
- P1 *FT-parameter 1* **1348** = 200
- P2 *FT-parameter 2* **1349** = 900
- A1 Not-negated output 2105
Optional: *FT-target output 1* **1350** = “2401 – FT-Outp. Buffer 1”
- A1 Negated output 2205
Optional: *FT-target output 2* **1351**

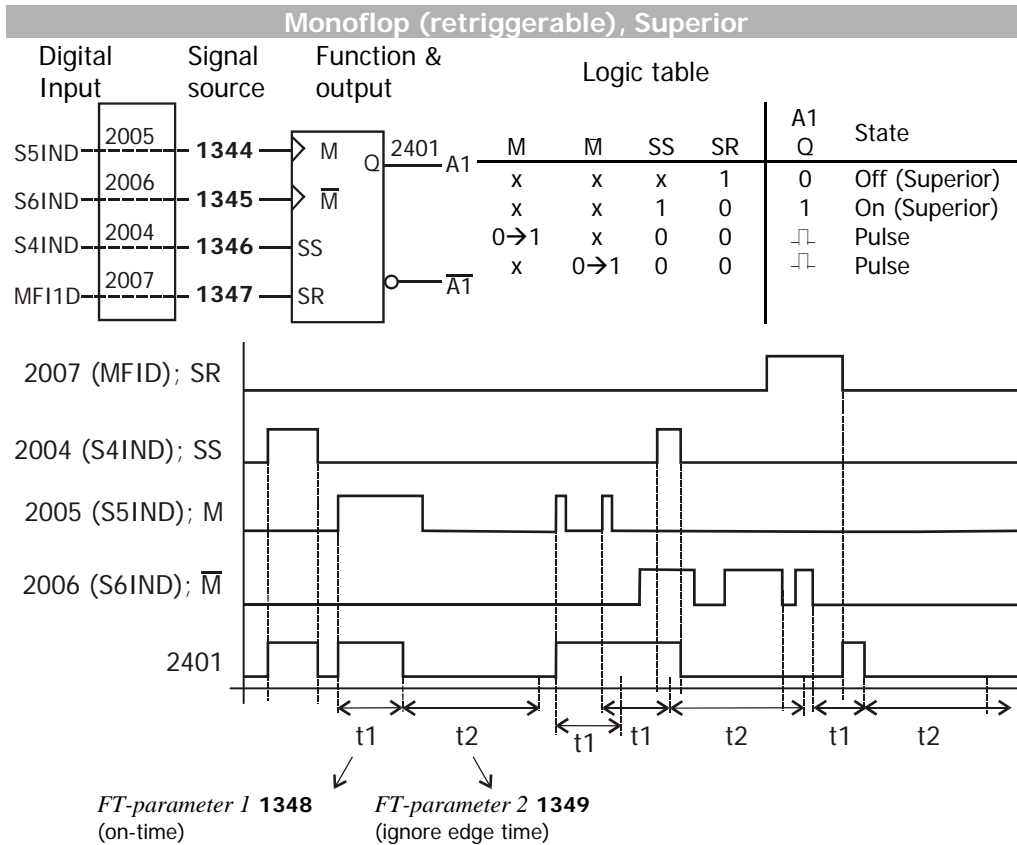

4.6.2 [160,161,162] Monoflop (retriggerable), Master

	Par#	Type	Function		Par#	Type	Function
E1	1344	b	M, Monoflop-edge 1	A1	1350	b	Output A1
E2	1345	b	\bar{M} , Monoflop-edge 2	A2	1351	b	Inverted output A2 = A1
E3	1346	b	Master Set-input	P1	1348	t	On-Time (High)
E4	1347	b	Master Reset-input	P2	1349	t	Ignore-Edge-Time

FT-instruction 1343 = 160 [ms], 161 [s] or 162 [min] – “Monoflop Master (retriggerable)”

Description:

The output signal becomes TRUE with the positive edge of input 1 or the negative edge of input 2. The time set in *FT-parameter 1 1348* is the On-Time (High) and the time set in *FT-parameter 2 1349* is the Ignore-Edge-Time (Low). The delay time starts again with each edge. TRUE at Master-Set input sets output TRUE. TRUE at Master-Reset input sets output FALSE.

The output signal can be used within the function table not-negated (21xx) and negated (22xx). The output signal is available via parameter *FT-target output 1 1350*. Via parameter *FT-target output 2 1351*, the inverted output signal is available.

Master Set and Master Reset are connected parallel with the function and change the state of the function as soon as the signal is present.

Example:

The positive edge of S5IND or the negative edge of S6IND shall switch on the output for 5 s. The “Out”-Time is 10 s.

<i>FT-input buffer 1362</i>	Index 1	Index 2	Index 3	Index 4	Index 5	Index 6	Index 7	...
	73-S4IND	74-S5IND	75-S6IND	76-MF1D	...

Settings in (i.e.) Index 5 of function table:

- FT-instruction 1343* = "161 – Monoflop Master s (retriggerable)",
- M *FT-input 1 1344* = "2005 – FT-Input Buffer 5",
- \bar{M} *FT-input 2 1345* = "2006 – FT-Input Buffer 6",
- MS *FT-input 3 1346* = "2004 – FT-Input Buffer 4",
- MR *FT-input 4 1347* = "2007 – FT-Input Buffer 7",
- P1 *FT-parameter 1 1348* = 200
- P2 *FT-parameter2 1349* = 900
- A1 Not-negated output 2105
Optional: *FT-target output 1 1350* = "2401 – FT-Outp. Buffer 1"
- A1 Negated output 2205
Optional: *FT-target output 2 1351*

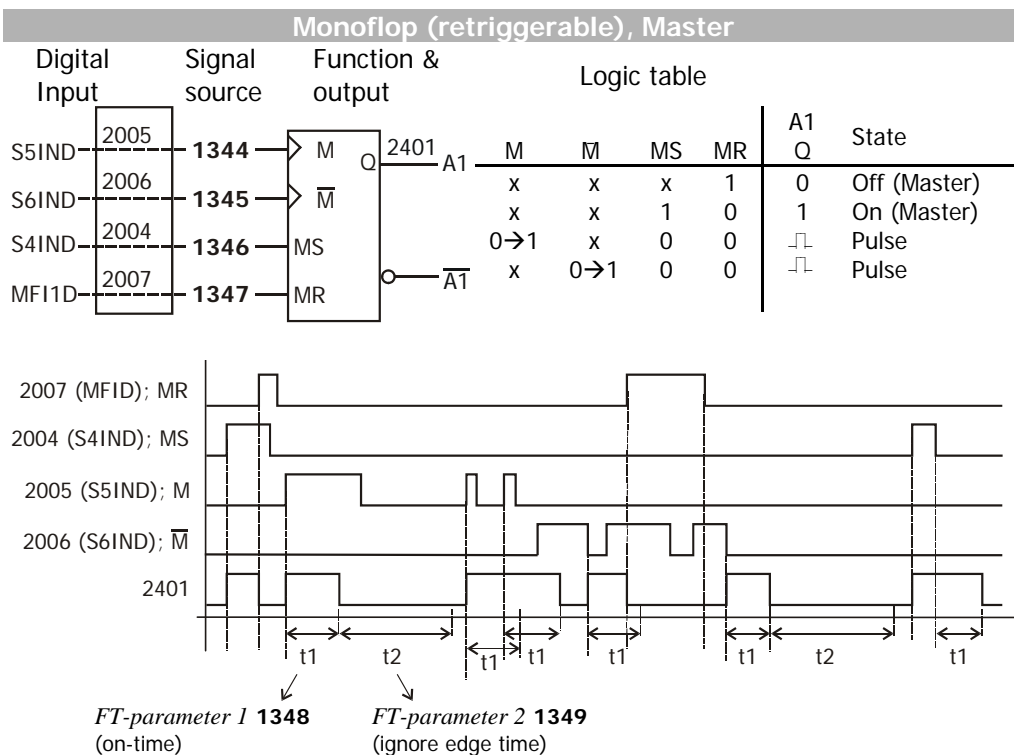

4.6.3 [70,71,72] Monoflop (not retriggerable), Superior

	Par#	Type	Function		Par#	Type	Function
E1	1344	b	M, Monoflop-edge 1	A1	1350	b	Output A1
E2	1345	b	\bar{M} , Monoflop-edge 2	A2	1351	b	Inverted output A2 = A1
E3	1346	b	Superior Set-input	P1	1348	t	On-Time (High)
E4	1347	b	Superior Reset-input	P2	1349	t	Ignore-Edge-Time

FT-instruction 1343 = 70 [ms], 71 [s] or 72 [min] - "Monoflop Superior (not retriggerable)"

Description:

The output signal becomes TRUE with the positive edge of input 1 or the negative edge of input 2. The time set in *FT-parameter 1 1348* is the On-Time (High) and the time set in *FT-parameter 2 1349* is the Ignore-Edge-Time (Low). The delay time starts again with each edge. TRUE at Master-Set input sets output TRUE. TRUE at Master-Reset input sets output FALSE.

The output signal can be used within the function table not-negated (21xx) and negated (22xx). The output signal is available via parameter *FT-target output 1 1350*. Via parameter *FT-target output 2 1351*, the inverted output signal is available.

Inputs Superior Set and Superior Reset are connected in series with the function. Levels on toggle inputs E1 and E2 are processed internally. As soon as the Superior Set or Superior Reset is reset, the output is switched to the internally saved value.

Example:

The positive edge of S5IND or the negative edge of S6IND shall switch on the output for 200 ms. The "Out"-Time is 900 ms.

<i>FT-input buffer 1362</i>	Index 1	Index 2	Index 3	Index 4	Index 5	Index 6	Index 7	...
	73-S4IND	74-S5IND	75-S6IND	76-MF11D	...

Settings in (i.e.) Index 10 of function table:

- FT-instruction 1343* = "70 – Monoflop Superior ms (not retriggerable)",
- M *FT-input 1 1344* = "2005 – FT-Input buffer 5",
- \bar{M} *FT-input 2 1345* = "2006 – FT-Input buffer 6",
- SS *FT-input 3 1346* = "2004 – FT-Input buffer 4",
- SR *FT-input 4 1347* = "2007 – FT-Input buffer 7",
- P1 *FT-parameter 1 1348* = 200
- P2 *FT-parameter 2 1349* = 900
- A1 Not-negated output 2110
Optional: *FT-target output 1 1350* = "2401 - FT-Outp. Buffer 1"
- A1 Negated output 2210
Optional: *FT-target output 2 1351*

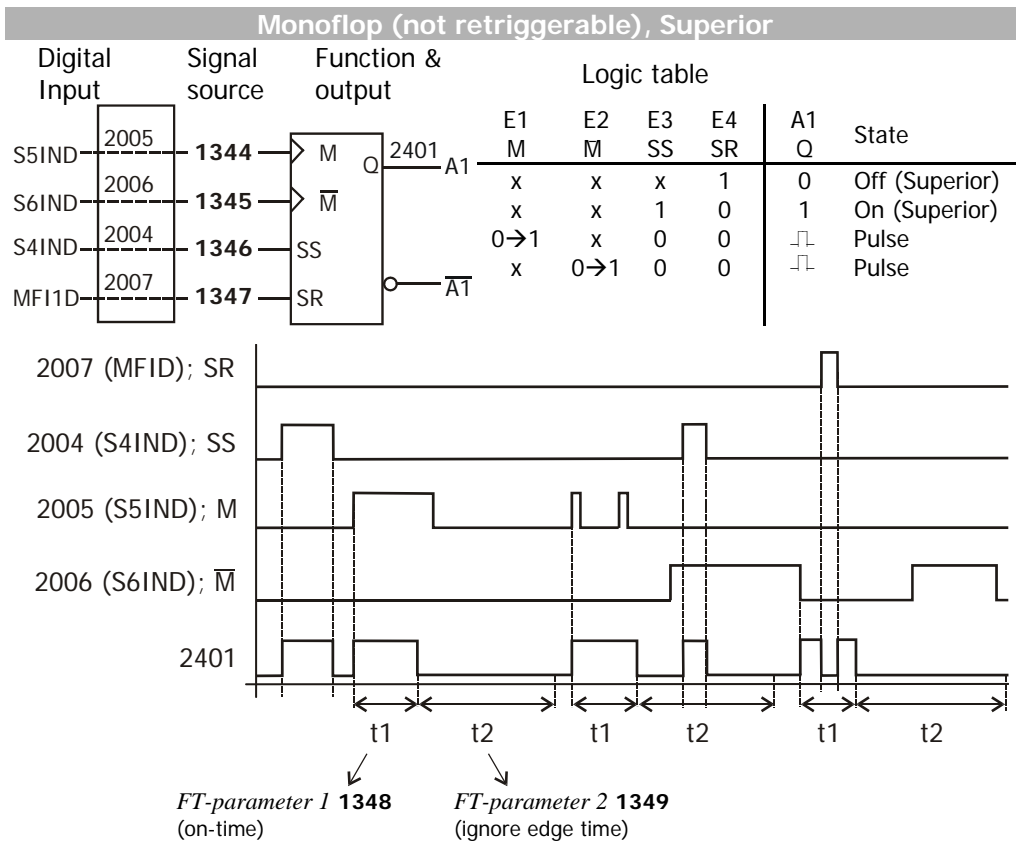

4.6.4 [170,171,172] Monoflop (not retriggerable), Master

	Par#	Type	Function		Par#	Type	Function
E1	1344	b	M, Monoflop-edge 1	A1	1350	b	Output A1
E2	1345	b	\bar{M} , Monoflop-edge 2	A2	1351	b	Inverted output A2 = A1
E3	1346	b	Master Set-input	P1	1348	t	On-Time (High)
E4	1347	b	Master Reset-input	P2	1349	t	Ignore-Edge-Time

FT-instruction 1343 = 170 [ms], 171 [s] or 172 [min] – "Monoflop Master (not retriggerable)"

Description:

The output signal becomes TRUE with the positive edge of input 1 or the negative edge of input 2. The time set in *FT-parameter 1 1348* is the On-Time (High) and the time set in *FT-parameter 2 1349* is the Ignore-Edge-Time (Low). The delay time starts again with each edge.

TRUE at Master-Set input sets output TRUE. TRUE at Master-Reset input sets output FALSE.

The output signal can be used within the function table not-negated (21xx) and negated (22xx). The output signal is available via parameter *FT-target output 1 1350*. Via parameter *FT-target output 2 1351*, the inverted output signal is available.

Master Set and Master Reset are connected parallel with the function and change the state of the function as soon as the signal is present.

Example:

The positive edge of S5IND or the negative edge of S6IND shall switch on the output for 5 s. The "Out"-Time is 10 s.

<i>FT-input buffer 1362</i>	Index 1	Index 2	Index 3	Index 4	Index 5	Index 6	Index 7	...
	73-S4IND	74-S5IND	75-S6IND	76-MF11D	...

Settings in (i.e.) Index 8 of function table:

- FT-instruction 1343* = "171 – Monoflop Master s (not retriggerable)",
- M *FT-input 1 1344* = "2005 – FT-Input buffer 5",
- \bar{M} *FT-input 2 1345* = "2006 – FT-Input buffer 6",
- MS *FT-input 3 1346* = "2004 – FT-Input buffer 4",
- MR *FT-input 4 1347* = "2007 – FT-Input buffer 7",
- P1 *FT-parameter 1 1348* = 5
- P2 *FT-parameter 2 1349* = 10
- A1 Not-negated output 2108
Optional: *FT-target output 1 1350* = "2401 – FT-Outp. Buffer 1"
- A1 Negated output 2208
Optional: *FT-target output 2 1351*

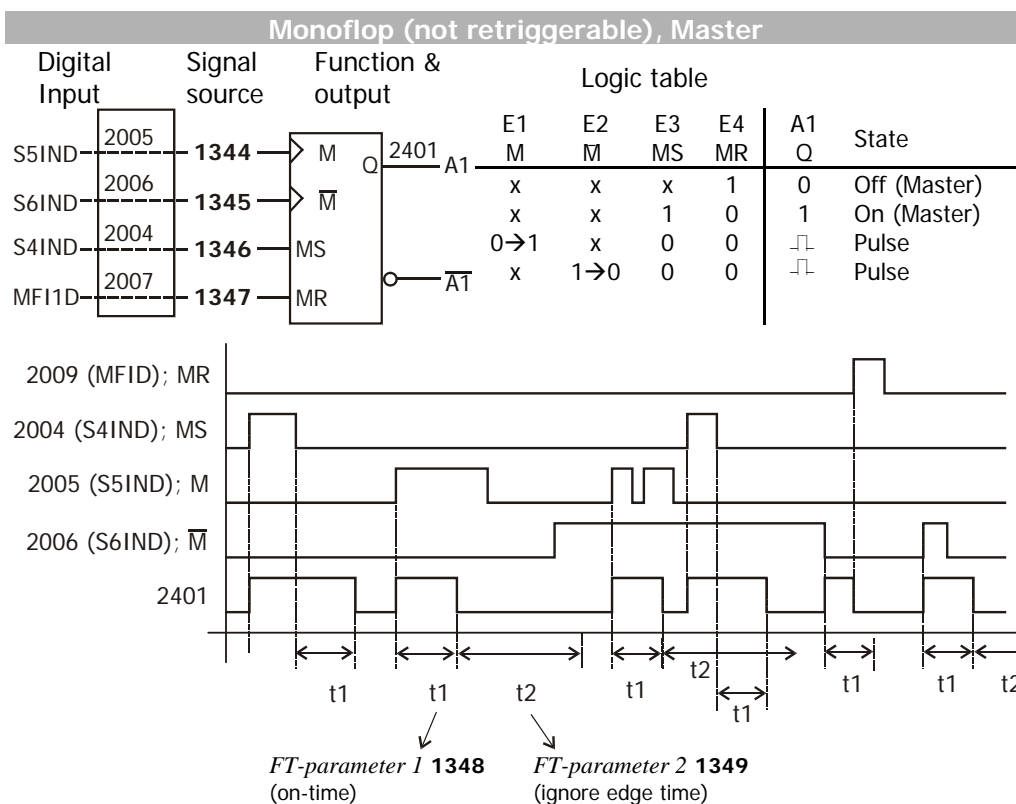

4.6.5 [80,81,82] Clock generator, Superior

	Par#	Type	Function		Par#	Type	Function
E1	1344	b	S Clock generator 1	A1	1350	b	Output A1
E2	1345	b	S Clock generator 2	A2	1351	b	Inverted output A2 = A1
E3	1346	b	Superior Set-input	P1	1348	t	On-Time (High)
E4	1347	b	Superior Reset-input	P2	1349	t	Off-Time (Low)

FT-instruction 1343 = 80 [ms], 81 [s] or 82 [min] – “Clock Generator Superior”

Description:

As long as Input 1 is TRUE and Input 2 is FALSE, the set pulse pattern is output. The pulse pattern at the output always starts with TRUE. The clock pattern is defined by the on-time and the off-time. The time set in *FT-parameter 1 1348* is the on-time (High) and the time set in *FT-parameter 2 1349* is the off-time (Low).

The output signal can be used within the function table not-negated (21xx) and negated (22xx). The output signal is available via parameter *FT-target output 1 1350*. Via parameter *FT-target output 2 1351*, the inverted output signal is available.

Inputs Superior Set and Superior Reset are connected in series with the function. Levels at Set input E1 and Reset input E2 are processed internally. As soon as the Superior Set or Superior Reset is reset, the output is switched to the internally saved value.

Example:

If S5IND=TRUE and S6IND=FALSE → Pulse 100 ms on, 150 ms off.

<i>FT-input buffer 1362</i>	Index 1	Index 2	Index 3	Index 4	Index 5	Index 6	...
	70-Inverter Release	71-S2IND	72-S3IND	73-S4IND	74-S5IND	74-S6IND	...

Settings in (i.e.) Index 6 of function table:

- FT-instruction 1343* = “80 – Clock Generator Superior ms”,
- S *FT-input 1 1344* = “2005 – FT-Input Buffer 5”,
- S *FT-input 2 1345* = “2006 – FT-Input Buffer 6”,
- SS *FT-input 3 1346* = “2004 – FT-Input Buffer 4”,
- SR *FT-input 4 1347* = “2002 – FT-Input Buffer 2”,
- P1 *FT-parameter 1 1348* = 100
- P2 *FT-parameter 2 1349* = 150
- A1 Not-negated output 2106
Optional: *FT-target output 1 1350* = “2401 - FT-Outp. Buffer 1”
- A1 Negated output 2206
Optional: *FT-target output 2 1351*

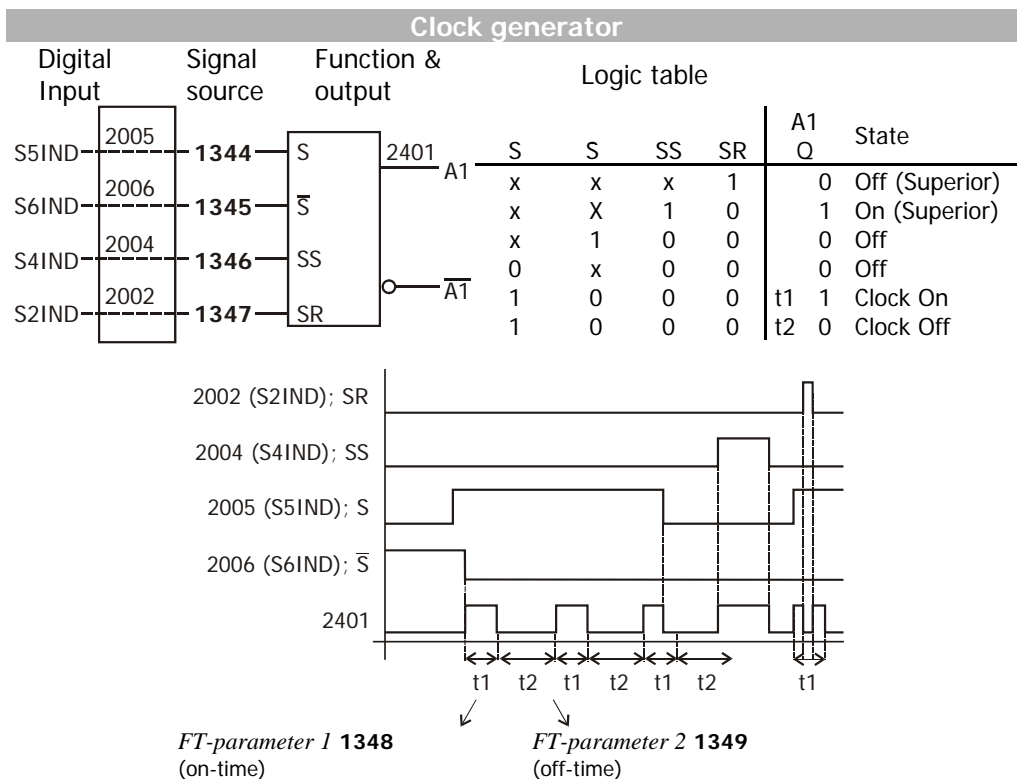

4.6.6 [180,181,182] Clock generator, Master

	Par#	Type	Function		Par#	Type	Function
E1	1344	b	S Clock generator 1	A1	1350	b	Output A1
E2	1345	b	S Clock generator 2	A2	1351	b	Inverted output A2 = A1
E3	1346	b	Master Set-input	P1	1348	t	On-Time (High)
E4	1347	b	Master Reset-input	P2	1349	t	Off-Time (Low)

FT-instruction 1343 = 180 [ms], 181 [s] or 182 [min] - "Clock Generator Master"

Description:

As long as Input 1 is TRUE and Input 2 is FALSE, the set pulse pattern is output. The pulse pattern at the output always starts with TRUE. The clock pattern is defined by the on-time and the off-time. The time set in *FT-parameter 1 1348* is the on-time (High) and the time set in *FT-parameter 2 1349* is the off-time (Low).

The output signal can be used within the function table not-negated (21xx) and negated (22xx). The output signal is available via parameter *FT-target output 1 1350*. Via parameter *FT-target output 2 1351*, the inverted output signal is available.

Master Set and Master Reset are connected parallel with the function and change the state of the function as soon as the signal is present.

Example:

If S5IND=TRUE and S6IND=FALSE → Pulse 100 ms on, 150 ms off.

<i>FT-input buffer 1362</i>	Index 1	Index 2	Index 3	Index 4	Index 5	Index 6	...
	70-Inverter Release	71-S2IND	72-S3IND	73-S4IND	74-S5IND	74-S6IND	...

Settings in (i.e.) Index 6 of function table:

- FT-instruction 1343* = "180 – Clock Generator Master ms",
- S *FT-input 1 1344* = "2005 – Input buffer 5",
- S *FT-input 2 1345* = "2006 – Input buffer 6",
- MS *FT-input 3 1346* = "2004 – Input buffer 4",
- MR *FT-input 4 1347* = "2002 – Input buffer 2",
- P1 *FT-parameter 1 1348* = 100
- P2 *FT-Parameter2 1349* = 150
- A1 Not-negated output 2106
- Optional: *FT-target output 1 1350* = "2401 - FT-Output buffer 1"
- A1 Negated output 2206
- Optional: *FT-target output 2 1351*

Clock generator, Master

Digital Input	Signal source	Function & output	Logic table				A1	State		
S5IND	2005	S	2401	S	S	MS	MR	Q		
S6IND	2006	\bar{S}	A1	x	x	x	1	0	Off (Master)	
S4IND	2004	MS		x	X	1	0	1	On (Master)	
S2IND	2002	MR	$\bar{A1}$	x	1	0	0	0	Off	
				0	x	0	0	0	Off	
				1	0	0	0	t1	1	Clock On
				1	0	0	0	t2	0	Clock Off

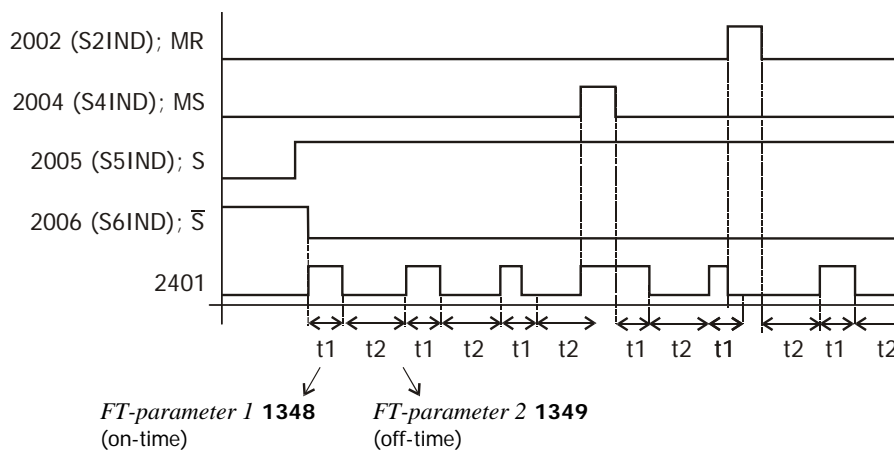

4.7 Digital Multiplexor

4.7.1 [90] Digital Multiplexor (data set number)

	Par#	Type	Function		Par#	Type	Function
E1	1344	b	Input data set 1	A1	1350	b	Output A1
E2	1345	b	Input data set 2	A2	1351	b	Inverted output A2 = A1
E3	1346	b	Input data set 3	P1	1348	-	-
E4	1347	b	Input data set 4	P2	1349	-	-

FT-instruction 1343 = "90 - Digital Multiplexor (data set no.)"

Description:

Depending on the current data set, the input values are passed on to the output values.

In actual values, you can read: *Active Data Set 249* = 1.

The signal at digital input S31ND is taken over in the signal source "2401 - FT-Outp. Buffer 1". Signal "2401 - FT-output buffer 1" can be output via a digital output or processed by other functions.

Example:

- When data set 1 is active, the value of S5IND is set to the output.
- When data set 2 is active, the value of S3IND is set to the output.
- When data set 3 is active, the value of EM-S1IND is set to the output.
- When data set 4 is active, the value of EM-S2IND is set to the output.

<i>FT-input buffer</i> 1362	Index 1 74-S5IND	Index 2 320-EM-S1IND	Index 3 321-EM-S2IND	Index 9 72-S3IND
------------------------------------	---------------------	-------------------------	-------------------------	---------------------

Settings in (i.e.) Index 6 of function table:

FT-instruction **1343** = "90 - Digital Multiplexor (Data set number)",

E1 *FT-input 1* **1344** = "2001 - FT-Input Buffer 1",

E2 *FT-input 2* **1345** = "2009 - FT-Input Buffer 9",

E3 *FT-input 3* **1346** = "2002 - FT-Input Buffer 2",

E4 *FT-input 4* **1347** = "2003 - FT-Input Buffer 3",

A1 Not-negated output 2106

Optional: *FT-target output 1* **1350** = "2401 - FT-Outp. Buffer 1"

A1 Negated output 2206

Optional: *FT-target output 2* **1351**

Digital Multiplexor (Data set number)

Active Data Set 249	2401
1	E1
2	E2
3	E3
4	E4

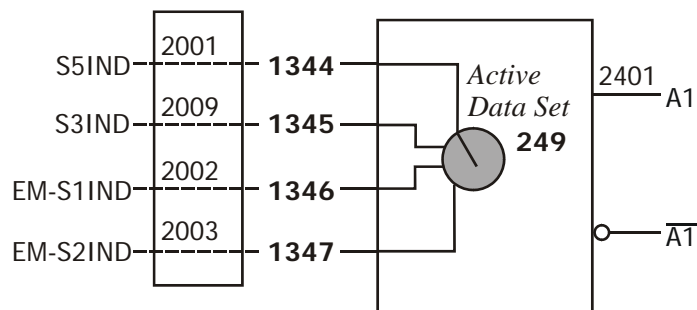

4.8 Switch

4.8.1 [91] Switch Data Set

	Par#	Type	Function
E1	1344	b	Input 1 (highest priority)
E2	1345	b	Input 2
E3	1346	b	Input 3
E4	1347	b	Input 1 (lowest priority)

	Par#	Type	Function
A1	1350	b	Output A1
A2	1351	b	Inverted output A2 = A1
P1	1348	-	-
P2	1349	-	-

FT-instruction **1343** = "91 - Switch Data Set"

Description:

A data set is selected via the input values.

Switch Data Set				
<i>FT-input 1</i> 1344	<i>FT-input 2</i> 1345	<i>FT-input 3</i> 1346	<i>FT-input 4</i> 1347	Data Set
1	x	x	x	1
0	1	x	x	2
0	0	1	x	3
0	0	0	1	4
0	0	0	0	Data set via contacts

4.9 Fault functions

4.9.1 [95] Trigger a fault

	Par#	Type	Function		Par#	Type	Function
E1	1344	b	Trigger user-defined error 1	A1	1350	-	-
E2	1345	b	Trigger user-defined error 2	A2	1351	-	-
E3	1346	b	Trigger user-defined error 3	P1	1348	i	Switch-off behavior
E4	1347	b	Trigger user-defined error 4	P2	1349	-	-

FT-instruction 1343 = "95 - Trigger a Fault"

Description:

If one of the inputs is TRUE the corresponding user-defined error is triggered. The power output stage is switched-off. The error cannot be acknowledged while the input remains in state TRUE.

For example the function can be used to stop the drive via external events. The user-defined error is displayed via an error code.

P1 determines the switch-off behavior. The error switch-off can be carried out immediately or first the drive can be shut down.

- P1 = 0: No error switch-off (disabled)
- P1 = 1: Shutdown and error switch-off
- P1 = 2: Emergency-stop and error switch-off
- P1 = 3: Error switch-off immediately

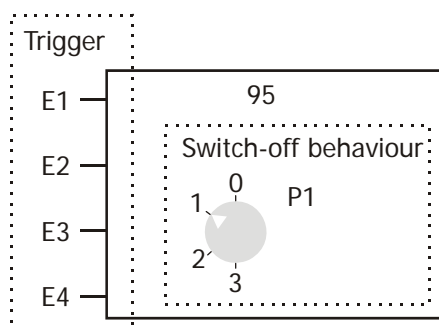

Value	Logic state				Trigger user-defined error	Function
	E1	E2	E3	E4		
"0"	1	0	0	0	1	No error switch-off
	0	1	0	0	2	
	0	0	1	0	3	
	0	0	0	1	4	
"1"	1	0	0	0	1	Shutdown and error switch-off
	0	1	0	0	2	
	0	0	1	0	3	
	0	0	0	1	4	
"2"	1	0	0	0	1	Emergency-stop and error switch-off
	0	1	0	0	2	
	0	0	1	0	3	
	0	0	0	1	4	
"3"	1	0	0	0	1	Error switch-off immediately
	0	1	0	0	2	
	0	0	1	0	3	
	0	0	0	1	4	

4.9.2 [96] Reset a fault

	Par#	Type	Function		Par#	Type	Function
E1	1344	b	Input error-reset + (rising edge)	A1	1350	b	"Error can be acknowledged."
E2	1345	b	Input error-reset - (falling edge)	A2	1351	b	Inverted output = A1
E3	1346	-	-	P1	1348	-	-
E4	1347	-	-	P2	1349	-	-

FT-instruction 1343 = "96 - Reset a Fault"

Description:

The output 1 is TRUE if an error is signaled and can be acknowledged.

With every rising signal edge at input 1 or falling edge input 2 a signaled error is acknowledged. If the error cannot (yet) be acknowledged the function does not react.

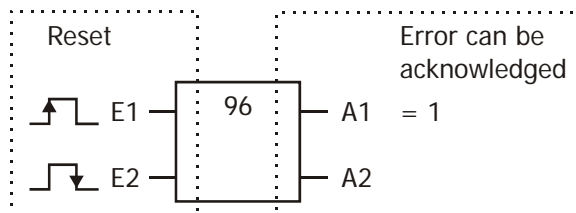

A1	E1	E2	Function
1	0→1	x	Acknowledge error
0			No reaction
1	x	1→0	Acknowledge error
0			No reaction
E1	x	x	Acknowledge error automatically

Note:

An error is acknowledged automatically if output 1 is connected to input 1.

4.10 Debouncer

4.10.1 [97] Debouncer

	Par#	Type	Function
E1	1344	b	Input value 1
E2	1345	-	-
E3	1346	b	Master Set
E4	1347	b	Master Reset

	Par#	Type	Function
A1	1350	b	Input value 1 debouncing
A2	1351	b	Inverted output = -A1
P1	1348	i	Delay rising signal edge in ms
P2	1349	i	Delay falling signal edge in ms

FT-instruction **1343** = „97 - Debouncer“

Description:

The input value 1 is forwarded to the output if the input value is constant for the delay time. The delay time for the rising edge of the input signal can be set in P1. The delay time for the falling edge of the input signal can be set in P2.

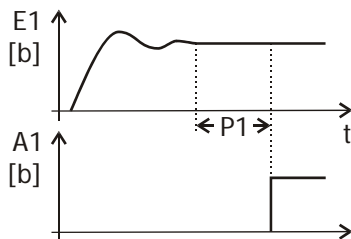

Master Set: „TRUE“ at E3 sets A1 to „TRUE“.
 Master-Reset: „TRUE“ at E4 sets A1 to „FALSE“.
 Priority: First Master-Reset, second Master-Set.

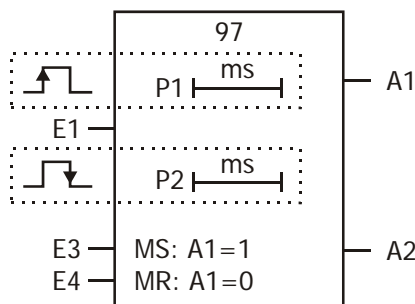

4.11 No Operation

4.11.1 [99] NOP

	Par#	Type	Function
E1	1344		
E2	1345		
E3	1346		
E4	1347		

	Par#	Type	Function
A1	1350		
A2	1351		
P1	1348		
P2	1349		

FT-instruction **1343** = "99 - NOP"

4.12 Jump functions

4.12.1 [100] Jump function

	Par#	Type	Function
E1	1344	b	Jump function activation
E2	1345	b	Jump target P1/P2
E3	1346	b	Update input buffer
E4	1347	b	Update output buffer

	Par#	Type	Function
A1	1350	-	-
A2	1351	-	-
P1	1348	i	Jump target P1
P2	1349	i	Jump target P2

FT-instruction 1343 = "100 - Jump Function"

Description:

This function enables jumps in the sequence of the function table to other instructions.

Enable

Input 1 {Parameter *FT-input 1 1344*} activates the jump function

Input 1 = TRUE: jump function is executed

Input 1 = FALSE: jump function is not executed

Jump target

Input 2 {parameter *FT-input 2 1345*} defines the jump target.

Input 2 = TRUE: Jump to instruction set in parameter *FT-parameter 1 1348*

Input 2 = FALSE: Jump to instruction set in parameter *FT-parameter 2 1349*

Updating of input buffer

TRUE at input 3 {parameter *FT-input 3 1346*} updates the input buffer. The values of the digital inputs and signal sources in the input buffer {parameter *FT-input buffer 1362*} are updated.

Updating of output buffer (output buffer values)

TRUE on Input 4 {parameter *FT-input 4 1347*} updates the values of output signals "2401 - FT-Outp. Buffer 1" to "2416 - FT-Outp. Buffer 16". The updated values are available to digital outputs (e.g. S1OUT) and functions linked to FT-instruction outputs (e.g. Start Clockwise, Switch Data Set).

Example:

FT-instruction 1343 = "100 - Jump Function"

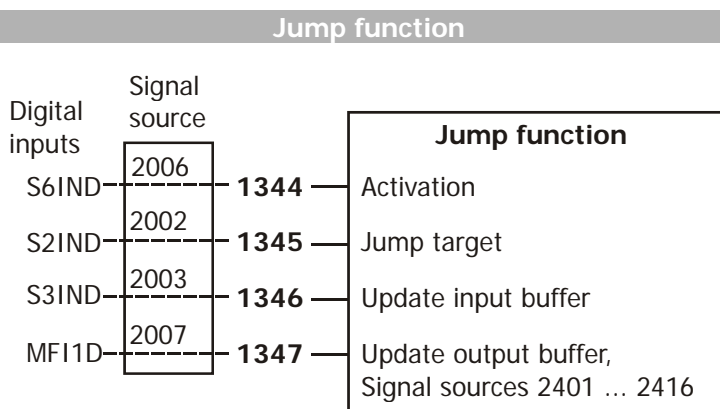

E1	E2	E3	E4	Jump
0	x	x	x	Jump to next instruction (index I + 1)
1	1	x	x	Jump to instruction set in <i>FT-parameter 1 1348</i> .
1	0	x	x	Jump to instruction set in <i>FT-parameter 2 1349</i> .

E1	E2	E3	E4	Update
x	x	1	x	Update input buffer (2001 ... 2016).
x	x	x	1	Update output buffer (2401 ... 2416).

Note:

At first, the output buffer is written and the input buffer is set. Then, the jump event is evaluated (based on the updated buffers) and executed.

4.12.2 [101] Jump function for loops

	Par#	Type	Function		Par#	Type	Function
E1	1344	b	Interrupt loop	A1	1350	-	-
E2	1345	b	Restart loop	A2	1351	-	-
E3	1346	b	Update input buffer	P1	1348	i	Jump target (Index)
E4	1347	b	Update output buffer	P2	1349	i	Number of repetitions

FT-instruction 1343 = „101 - Jump Function for loops“

Description:

The instruction which is designated in P1 is repeated. P2 is the number of repetitions. The loop can be interrupted or restarted via the inputs.

- P1 is the jump target (function which has to be repeated).
- P2 is the number of repetitions.

The jump function can be placed at a sequence of instructions, which have to be repeated. An internal counter is set to the value of P2 and is decreased with every function call.

- If input E1 is TRUE the loop is interrupted abortively. The jump is not executed and the internal counter is reset to the starting value P2.
- If input E2 is TRUE the loop is restarted. The jump is executed and the internal counter is reset to the starting value P2.
- If input E3 is TRUE the input buffer is updated.
- If input E4 is TRUE the output buffer is updated.

E1	E2	E3	E4	Function
1	0	0	0	Interruption, reset to starting value P2
0	1	0	0	Restart, reset to starting value P2
0	0	1	0	Update input buffer
0	0	0	1	Update output buffer

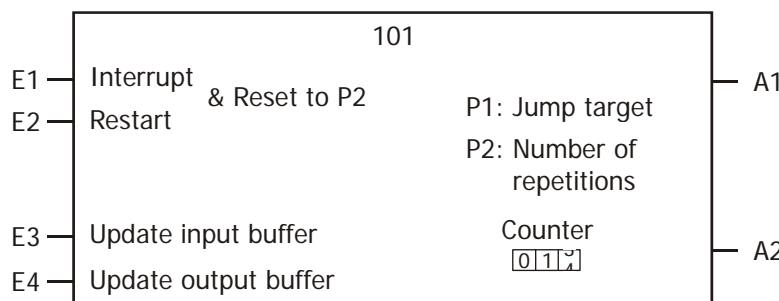
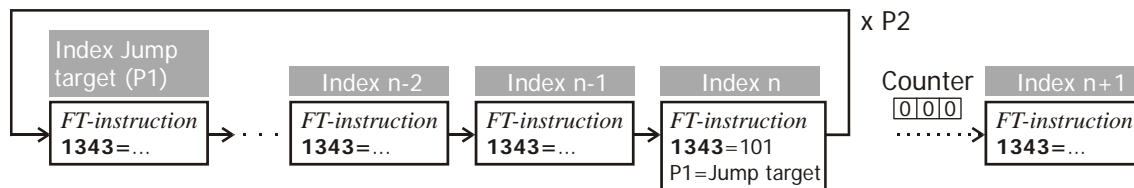

5 Description of the analog functions

In this chapter all analog functions are explained with examples. An analog function is defined as follows:

An analog function has at least one analog input or output value. Additional inputs may be used as digital signal.

If the function has an analog output value (A1), the second output value A2 is the inverted (negative) value.

If the function has analog and digital (bool) inputs, the analog inputs have the smaller order numbers (E1 = analog, E4 = Boolean).

In the examples, the standard settings of the input buffers are used. Deviating settings can be used in the instructions.

Note:

To enhance the overview, the descriptions use the designation A_n (not inverted). The negated output $A_{\bar{n}}$ (inverted) can be used freely additionally or instead of A_n .

Note:

In some functions, the output A2 is not used as inverted output, but used for function specific values. These functions are marked with "Long" for long variable.

In the descriptions the following abbreviations are used:

b	Boolean	(TRUE / FALSE) = 1 Bit
%	Percentage value	With/without sign (int/uint) = 2 Byte = 16 Bit
L	Long	Variable of Type long = 4 Byte = 32 Bit
i	Arbitrary number	
Par#	Parameter number	
0	"Low" state.	Represents logic states in logic tables.
1	"High" state.	Represents logic states in logic tables.
FALSE	"Low" state.	Represents logic states in function descriptions.
TRUE	"High" state.	Represents logic states in function descriptions.

5.1 Parameters for behavior

The behavior of the FT-instructions can be adjusted via *FT-parameter 1 1348* and *FT-parameter 2 1349*. The function of these parameters is depends on the selected instruction (parameter *FT-instruction 1343*).

Parameter		Setting		
No.	Description	Min.	Max.	Fact. sett.
1348	FT-parameter 1	0	65535	10
1349	FT-parameter 2	0	65535	10

5.2 Comparators

5.2.1 [301,302] Comparator (Compare two Variables)

	Par#	Type	Function		Par#	Type	Function
E1	1344	%	Comparison Value 1	A1	1350	b	Output E1 > E2
E2	1345	%	Comparison Value 2	A2	1351	b	A1 inverted
E3	1346	b	Master-Set	P1	1348	%	positive Hysteresis (xxx,xx%)
E4	1347	b	Master-Reset	P2	1349	%	negative Hysteresis (xxx,xx%)

FT-instruction 1343 = "301 - Comp. (V V)" (Comparator, Comparison of two Variables)

FT-instruction 1343 = "302 - Comp. (V V), value (Comparator, Comparison of two Variables, absolute value)"

Description:

This function compares inputs E1 and E2.

A1 is TRUE, if $E1 > E2$.

A1 is FALSE, if $E1 < E2$.

If a Hysteresis (P1 und P2) is set:

A1 is TRUE, if $E1 > (E2 + P1)$.

A1 is FALSE, if $E1 < (E2 - P2)$.

The comparator is separated into three working ranges:

Range 1	$(E2 + P1) < E1$	A1 = TRUE
Range 2	$(E2 - P2) < E1 < (E2 + P1)$	A1 remains unchanged.
Range 3	$E1 < (E2 - P2)$	A1 = FALSE
		A2 = AT

The output value can be changed with the Boolean inputs E3 and E4:

Master-Set sets output A1 to „TRUE“.

Master-Reset sets output A1 to „FALSE“. Master-Reset has a higher priority than Master-Set.

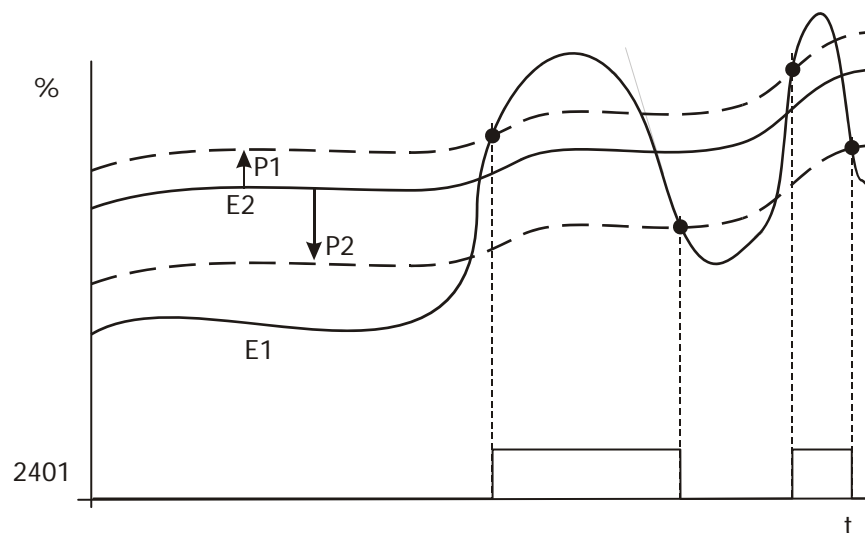
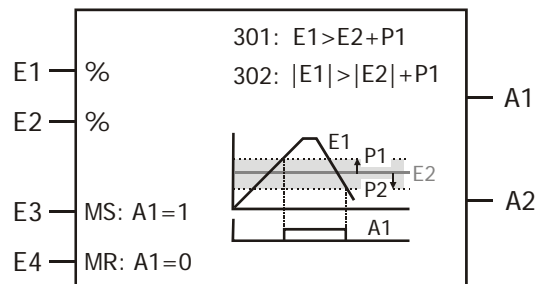

Note:

This function compares inputs E1 and E2. Percentage values [%] mean, that the value is defined in percent with two decimal places.

For example: Value $12345_{IN} = 123.45 \% = 1.2345$

5.2.2 [303,304] Comparator (Compare constant to variable)

	Par#	Type	Function		Par#	Type	Function
E1	1344	%	Comparison value 1	A1	1350	b	Output E1 > P1
E2	1345	-	-	A2	1351	b	A1 inverted
E3	1346	b	Master-Set	P1	1348	%	upper threshold (xxx,xx%)
E4	1347	b	Master-Reset	P2	1349	%	lower threshold (xxx,xx%)

FT-instruction 1343 = "303 - Comp. (C V)" (Comparator, Comparison Constant/Variable)

FT-instruction 1343 = "304 - Comp. (C V), value" (Comparator, Comparison Constant/Variable), Absolute Value)

Description:

This function compares input E1 with the switching threshold P1 and P2.

A1 is TRUE, if $E1 > P1$ (upper threshold).

A1 is FALSE, if $E1 < P2$ (lower threshold).

A1 remains unchanged, if E1 is in the range between P2 and P1.

The comparator is separated into three working ranges:

Range 1	$P1 < E1$	A1 = TRUE
Range 2	$P2 < E1 < P1$	A1 remains unchanged
Range 3	$E1 < P2$	A1 = FALSE
		A2 = A1

The output value can be changed with the Boolean inputs E3 and E4:

Master-Set sets output A1 to „TRUE“.

Master-Reset sets output A1 to „FALSE“. Master-Reset has a higher priority than Master-Set.

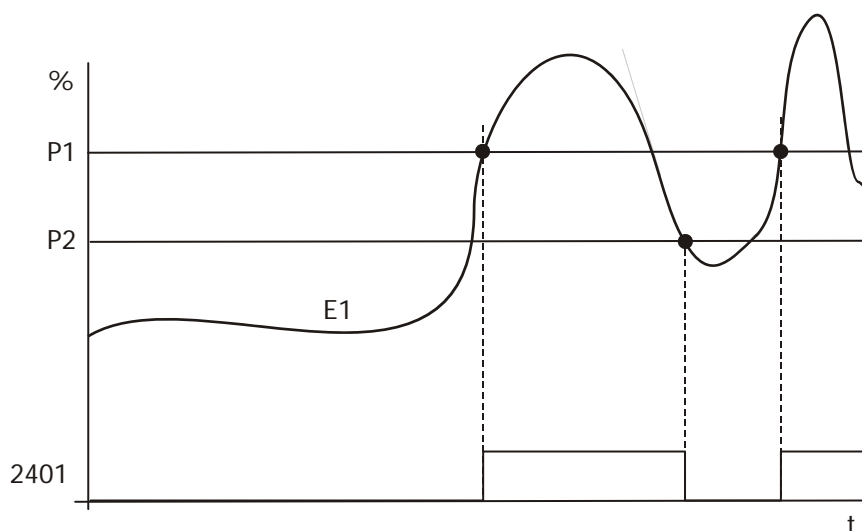
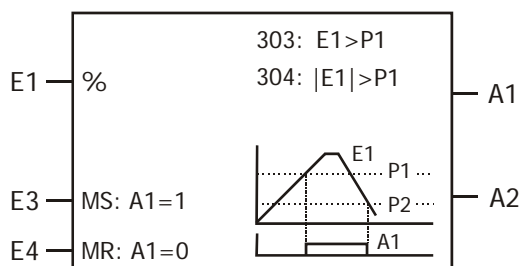

Note:

Percentage values [%] mean, that the value is defined in percent with two decimal places.

For example: Value $12345_{IN} = 123.45 \% = 1.2345$

Special case:

P2 (lower threshold) is set to a bigger value than P1 (upper threshold) (swapped thresholds):

A1 is TRUE, if $E1 > P1$.

A1 is reset, if E1 falls below P1 and P2 is not exceeded.

A1 is also reset, if P2 is exceeded first and then E1 drops below P2.

5.2.3 [308] Comparator Active Motion Block

	Par#	Type	Function		Par#	Type	Function
E1	1344	-	-	A1	1350	b	Output $E1 > E2$
E2	1345	-	-	A2	1351	b	A1 inverted
E3	1346	b	Master-Set	P1	1348	i	Motion block from
E4	1347	b	Master-Reset	P2	1349	i	Motion block to

FT-instruction 1343 = "308 - Comp. Active Motion Block"

Description:

This function compares the two parameters P1 and P2 with the current motion block. If the current motion block lies in between the two defined parameters, the output is set to TRUE.

The output of the comparator is set to TRUE, if the active motion block is in the range P1...P2.

The output value can be changed with the Boolean inputs E3 and E4:

Master-Set sets output A1 to „TRUE“.

Master-Reset sets output A1 to „FALSE“. Master-Reset has a higher priority than Master-Set.

Examples:

	P1	P2	1	2	3	4	5	6	7	8	9	10	11	12	13	14	15	16	17	18	19	20	21	22	23	24	25	26	27	28	29	30	31	32	
P1 < P2	5	7																																	
P1 > P2	20	10																																	

█: A1 = TRUE

Special case: $P1 > P2$:

A1 = TRUE if the active motion block is in the range in between 1 to P2 or P1 to 32.

5.2.4 [309] Position comparator (Long)

	Par#	Type	Function		Par#	Type	Function
E1	1344	L	Comparison Value 1	A1	1350	b	Output $E1 > E2$
E2	1345	L	Comparison Value 2	A2	1351	b	A1 inverted
E3	1346	b	Master-Set	P1	1348	%	positive Hysteresis (Low-word)
E4	1347	b	Master-Reset	P2	1349	%	negative Hysteresis (Low-word)

FT-instruction 1343 = "309 - Comp. (P P)" (Position comparator, Compares two variables) [absolute]

Description:

This function compares the inputs E1 and E2 with each other. This function is especially designed for Long-variables (Positions, Ramps).

A1 is TRUE, if $E1 > E2$.

A1 is FALSE, if $E1 < E2$.

If a Hysteresis (P1 and P2) is set:

A1 is TRUE, if $E1 > (E2 + P1)$.

A1 is FALSE, if $E1 < (E2 - P2)$.

A1 remains unchanged, if E1 lies in the range of the hysteresis: $(E2 - P2) < E1 < (E2 + P1)$.

The comparator is separated into three working ranges:

Range 1	$(E2 + P1) < E1$	A1 = TRUE
Range 2	$(E2 - P2) < E1 < (E2 + P1)$	A1 remains unchanged
Range 3	$E1 < (E2 - P2)$	A1 = FALSE
		A2 = A1

The output value can be changed with the Boolean inputs E3 and E4:

Master-Set sets output A1 to „TRUE“.

Master-Reset sets output A1 to „FALSE“. Master-Reset has a higher priority than Master-Set.

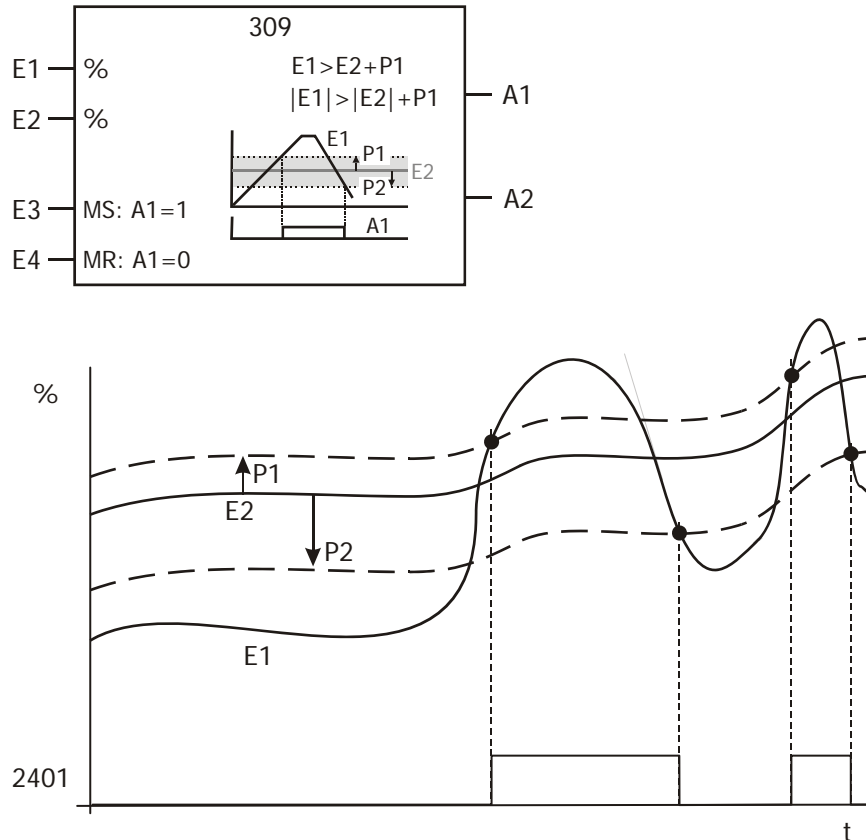

5.2.5 [310] Analogue Hysteresis

	Par#	Type	Function		Par#	Type	Function
E1	1344	%	Input value	A1	1350	b	Output
E2	1345	%	variable Hysteresis	A2	1351	b	A1 inverted
E3	1346	b	Start	P1	1348	%	Constant Hysteresis
E4	1347	b	Master-Reset	P2	1349	-	-

FT-instruction 1343 = "310 - Analog-Hysteresis"

Description:

If "Start" input value E3 is set, input value E1 is "hold" ("F" = E1).

Input value E1 applies constantly at output A1. The hysteresis is set via variable E2 and constant P1. Then the output value alters only if input value E1 exceeds or falls below the hysteresis.

$$E1 > F + (E2 + P1) \rightarrow A1 = E1$$

$$E1 < F - (E2 + P1) \rightarrow A1 = E1$$

$$F - (E2 + P1) < E1 < F - (E2 + P1) \rightarrow A1 = F$$

Master-Reset sets output A1 to FALSE.

When Master-Reset is reset, E3 has to be started anew.

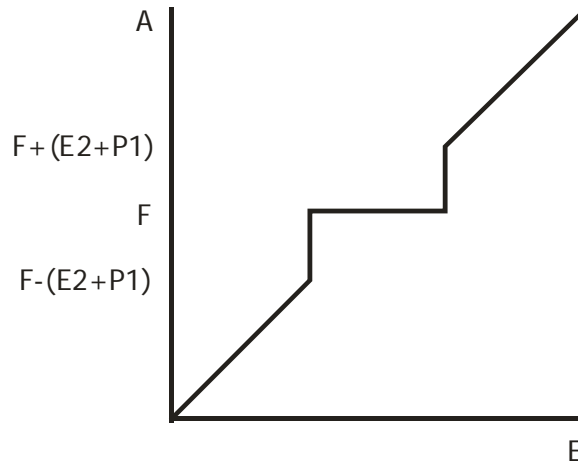

E3	E4	Function
1	0	Hold E1 constantly at A1.
x	1	Set A1 to FALSE.

Note:

Percentage values [%] mean, that the value is defined in percent with two decimal places.
 For example: Value $12345_{IN} = 123.45 \% = 1.2345$

5.2.6 [311,312] Window-Comparator (Compares two Variables)

	Par#	Type	Function
E1	1344	%	Comparison Value 1
E2	1345	%	Comparison Value 2
E3	1346	b	Master-Set
E4	1347	b	Master-Reset

	Par#	Type	Function
A1	1350	b	Output E1 > E2
A2	1351	b	A1 inverted
P1	1348	%	positive Window (xxx,xx%)
P2	1349	%	negative Window (xxx,xx%)

FT-instruction 1343 = "311 - W.-comp. (V V)" (Window-Comparator, two Variables)

FT-instruction 1343 = "312 - W.-comp. (V V), value" (Window-Comparator, two Variables, absolute value)

Description:

It is checked, that E1 is in the set range (window) around E2.
 A1 is TRUE, if E1 is in the range of E2. The range is set with P1 (positive window) and P2 (negative window).
 A1 is FALSE, if E1 is outside this range.

The comparator is separated into three working ranges:

Range 1	$(E2 + P1) < E1$	A1 = FALSE
Range 2	$(E2 - P2) < E1 < (E2 + P1)$	A1 = TRUE
Range 3	$E1 < (E2 - P2)$	A1 = FALSE

The output value can be changed with the Boolean inputs E3 and E4:

Master-Set sets output A1 to TRUE.

Master-Reset sets output A1 to FALSE. Master-Reset has a higher priority than Master-Set.

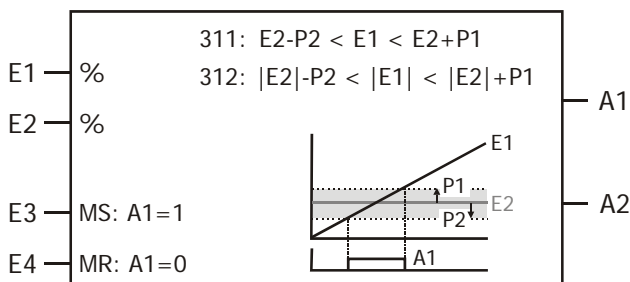

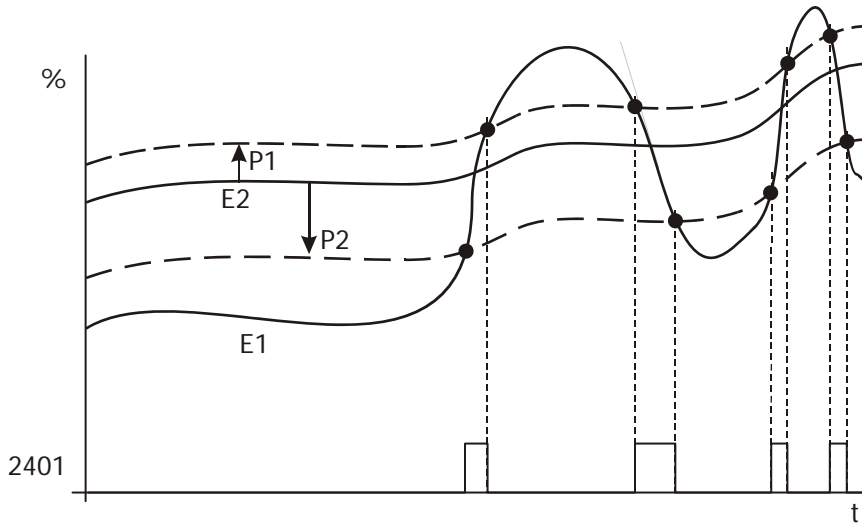

Note:

Percentage values [%] mean, that the value is defined in percent with two decimal places.
 For example: Value 12345_{IN} = 123.45 % = 1.2345

5.2.7 [313,314] Window-Comparator (Compares constant to variable)

	Par#	Type	Function		Par#	Type	Function
E1	1344	%	Comparison Value 1	A1	1350	b	Output E1 > E2
E2	1345			A2	1351	b	A1 inverted
E3	1346	b	Master-Set	P1	1348	%	positive Window (xxx,xx%)
E4	1347	b	Master-Reset	P2	1349	%	negative Window (xxx,xx%)

FT-instruction 1343 = "313 - W.-comp. (C V)" (Window-Comparator, comparison constant/variable)

FT-instruction 1343 = "314 - W.-comp. (C V), value" (Window-Comparator, comparison constant/variable, absolute value)

Description:

Via P1 and P2 a value range (window) is defined. This window is used to check if E1 is inside this range.

A1 is TRUE, if E1 is inside the range between P2 and P1.

A1 is FALSE, if E1 is outside the range.

The comparator is separated into three working ranges:

Range 1	$P1 < E1$	A1 = FALSE
Range 2	$P2 < E1 < P1$	A1 = TRUE
Range 3	$E1 < P2$	A1 = FALSE
		A2 = A1

The output value can be changed with the Boolean inputs E3 and E4:

Master-Set sets output A1 to „TRUE“.

Master-Reset sets output A1 to „FALSE“. Master-Reset has a higher priority than Master-Set.

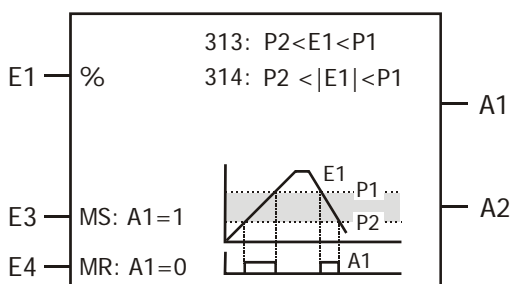

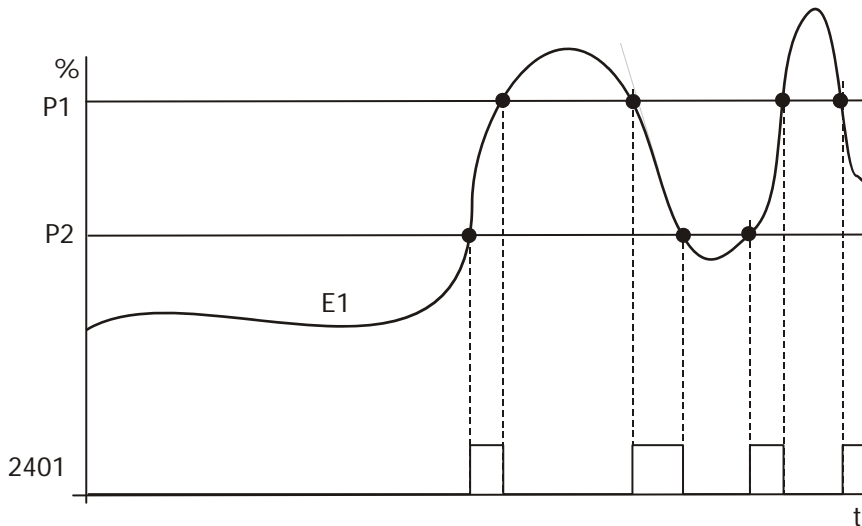

Note:

Percentage values [%] mean, that the value is defined in percent with two decimal places.
 For example: Value 12345_{IN} = 123.45 % = 1.2345

Special case:

P2 (negative window) is set to a bigger value than P1 (positive window) (swapped boundaries):
 A1 is TRUE, if E1 < P1 or E1 > P2.

A1 is FALSE, if E1 is inside the window defined by P1 and P2.

5.2.8 [320] Min/Max

	Par#	Type	Function
E1	1344	%	Input value 1
E2	1345	%	Input value 2
E3	1346	b	FALSE=Min/TRUE=Max
E4	1347	b	Master-Reset

	Par#	Type	Function
A1	1350	%	Min or Max (E1;E2;P1;P2)
A2	1351	%	A1 inverted
P1	1348	%	Constant value P1
P2	1349	%	Constant value P2

FT-instruction **1343** = "320 - Min/Max"

Description:

The variables E1 and E2 and the constants P1 and P2 are used to determine either the minimum or maximum value and put it out on output A1.

The **maximum** value is put out, if E3 is TRUE.

The **minimum** value is put out, if E3 is FALSE.

E3 = FALSE: A1 = -A2 = Minimum (E1, E2, P1, P2)
 E3 = TRUE: A1 = -A2 = Maximum (E1, E2, P1, P2)

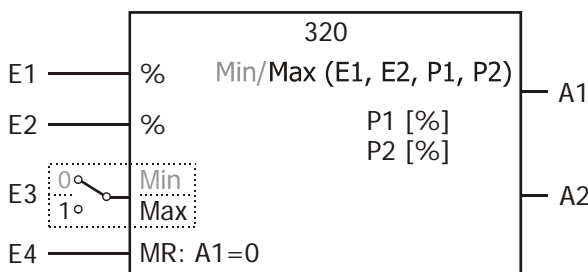

Note:

A setting for P1 or P2 to "0" deactivates the individual value while determining the minimum or maximum value.

If E2 is set to "9-Zero", the input E2 is deactivated while determining the minimum or maximum value.

As long as E4 (Master Reset) is TRUE, the output is FALSE.

Note:

Percentage values [%] mean, that the value is defined in percent with two decimal places.
For example: Value 12345_{IN} = 123.45 % = 1.2345

5.2.9 [321] Min/Max for Position Values (Long)

	Par#	Type	Function		Par#	Type	Function
E1	1344	Pos	Input value 1	A1	1350	Pos	Min or Max (E1;E2;P)
E2	1345	Pos	Input value 2	A2	1351	Pos	
E3	1346	b	FALSE=Min/TRUE=Max	P1	1348	Pos	Constant value
E4	1347	b	Master-Reset	P2	1349	Pos	

FT-instruction 1343 = "321 - Min/Max for Positions values"

Description:

The variables E1 and E2 and the constant P are used to determine either the minimum or maximum value and put it out on output A1.

The **maximum** value is put out, if E3 is TRUE.

The **minimum** value is put out, if E3 is FALSE.

E3 = FALSE: A = Minimum (E1, E2, P)
E3 = TRUE: A = Maximum (E1, E2, P)
with A1,P1: Low-word
 A2, P2 High-word

Note:

A setting for P1 or P2 to "0" deactivates the individual value while determining the minimum or maximum value.

If E2 is set to "9-Zero", the input E2 is deactivated while determining the minimum or maximum value.

Note:

The output value A2 is **not** the inverted value of A1.

The output A1 can be linked to other inputs for position values (long).

This function can also be used for ramp settings in configurations x40.

5.2.10 [322] Min/Max in time window

	Par#	Type	Function		Par#	Type	Function
E1	1344	%	Input value 1	A1	1350	%	Min or Max
E2	1345	-	-	A2	1351	%	A1 inverted
E3	1346	b	FALSE=Min/TRUE=Max	P1	1348	-	-
E4	1347	b	Master-Reset	P2	1349	-	-

FT-instruction 1343 = "322 - Min / Max in time window"

Description:

Over a specified time the **minimum** value of E1 is determined and put out on output A1 if E3 is TRUE and E4 is FALSE.

Or:

Over a specified time the **maximum** value of E1 is determined and put out on output A1 if E3 is FALSE and E4 is FALSE.

Or:

The current input value of E1 is put out on output A1, if E4 is TRUE.

The signal state of E3 specifies, if the minimum or maximum input value is put out. E4 has to be set to FALSE.

The time for the minimum or maximum value is determined with a signal on E4. The measurement of the minimum or maximum value begins with a negative edge on E4. The measurement begins anew with each negative edge on E4.

E3	E4	A1=
0	0	Minimum (E1)
1	0	Maximum (E1)
x	1	E1

Note:

Percentage values [%] mean, that the value is defined in percent with two decimal places.
 For example: Value $12345_{IN} = 123.45 \% = 1.2345$

5.2.11 [323] Min/Max for Positions (Long) in time window

	Par#	Type	Function		Par#	Type	Function
E1	1344	Pos	Input value 1	A1	1350	Pos	Min or Max (E1)
E2	1345	-	-	A2	1351	Pos	
E3	1346	b	FALSE=Min/TRUE=Max	P1	1348	-	High-word
E4	1347	b	Master-Reset	P2	1349	-	-

FT-instruction 1343 = "323 - Min/Max for Positions in time window"

Description:

Over a specified time the **minimum** value of E1 is determined and put out on output A1 if E3 is TRUE and E4 is FALSE.

Or:

Over a specified time the **maximum** value of E1 is determined and put out on output A1 if E3 is FALSE and E4 is FALSE.

Or:

The current input value of E1 is put out on output A1, if E4 is TRUE.

The signal state of E3 specifies, if the minimum or maximum input value is put out. E4 has to be set to „FALSE“.

The time for the minimum or maximum value is determined with a signal on E4. The measurement of the minimum or maximum value begins with a negative edge on E4. The measurement begins anew with each negative edge on E4.

E3	E4	A=
0	0	Minimum (E1)
1	0	Maximum (E1)
x	1	E1

Note:

The output value A2 is **not** the inverted value of A1.

The output A1 can be linked to other inputs for position values (long).

This function can also be used for ramp settings in configurations x40.

5.3 Mathematical function

Par#	Description	Formula	Limit values
1343=			
330	Addition and subtraction of input values and offset	$A1 = -A2 = E1 + E2 - E3 + P1 - P2$	$\pm 327.67\%$
331	Addition and subtraction of position values and offset. Result Long.	$A = E1 + E2 - E3 + P$ A1,P1 = Low-word A2,P2 = High-word	0 ... (2 ³² -1)
332	Multiplication of input values and factor.	$A1 = -A2 = E1 \times E2 \times P1$	$\pm 327.67\%$
333	Multiplication of position values and offset. Result Long.	$A2 \mid A1 = E1 \times E2 \times P1$ A1 = Low-word A2 = High-word	0 ... (2 ³² -1)
334	Multiplication of input value with constant fraction.	$A1 = -A2 = E1 \times \frac{P1}{P2}$	$\pm 327.67\%$
335	Multiplication of value Long.	Mult. long * Percent	
336	Division of input value by variable input values.	$A1 = -A2 = \frac{E1}{E2 \times E3}$	+P1 - P2 [$\pm 327.67\%$]
337	Division of input value by constant.	$A1 = -A2 = \frac{E1}{P1}$	$\pm P2$ [$\pm 327.67\%$]
338	Division of constant by input value (reciprocal).	$A1 = -A2 = \frac{P1}{E1}$	$\pm P2$ [$\pm 327.67\%$]
339	Multiplication and Division combined.	$A1 = -A2 = \frac{E1 \times E2}{E3}$	+P1 - P2 [$\pm 327.67\%$]
340	Average value of 3 input values. Multiplication with constant fraction as correction factor.	$A1 = -A2 = \frac{E1 + E2 + E3}{3} \times \frac{P1}{P2}$	$\pm 327.67\%$
341	Value of two orthogonal components. Multiplication with constant fraction.	$A1 = -A2 = \sqrt{E1^2 + E2^2} \times \frac{P1}{P2}$	$\pm 327.67\%$
342	Value of three orthogonal components. Multiplication with constant fraction.	$A1 = -A2 = \sqrt{E1^2 + E2^2 + E3^2} \times \frac{P1}{P2}$	$\pm 327.67\%$
350	Integrator	$A1 = -A2 = \frac{1}{P1} \int E1 dt + E2$	$\pm 327.67\%$
351	Differentiator (D-element)	$A1 = -A2 = \frac{1}{P1} \times \frac{dE1}{dt}$	$\pm 327.67\%$
360	Absolute Value	$A1 = -A2 = E1 $	$\pm 327.67\%$
361	Input value squared.	$A1 = -A2 = E1^2$	+ P2 [$\pm 327.67\%$]
362	Input value raised to the power of 3.	$A1 = -A2 = E1^3$	$\pm P2$ [$\pm 327.67\%$]
363	Square root of input value.	$A1 = -A2 = \sqrt{ E1 } \times \frac{ E1 }{E1}$; + E1 \Rightarrow A1 = + $\sqrt{ E1 }$ - E1 \Rightarrow A1 = - $\sqrt{ E1 }$	$\pm P2$ [$\pm 327.67\%$]

5.3.1 Addition and subtraction

5.3.1.1 [330] Add. A1=-A2=E1+E2-E3+P1-P2

	Par#	Type	Function		Par#	Type	Function
E1	1344	%	positive Input E1	A1	1350	%	A1 = E1 + E2 - E3 + P1 - P2
E2	1345	%	positive Input E2	A2	1351	%	inverted Output = -A1
E3	1346	%	negative Input E3	P1	1348	%	positive Offset
E4	1347	b	Master Reset	P2	1349	%	negative Offset

FT-instruction **1343** = "330 - Add. A1=-A2=E1+E2-E3+P1-P2"

Description:

This function adds the inputs E1 and E2 und subtracts input E3. P1 can additionally be used to add a positive offset, P2 for a negative offset.

$$A1 = -A2 = E1 + E2 - E3 + P1 - P2$$

The result is limited to $\pm 327.67\%$. Provisional results are not limited.

As long as E4 (Master Reset) is TRUE, the output value A1 is set to 0.

Example:

$$\begin{aligned}
 E1 &= 3240 (=32.40 \%) & A1 &= 32.40 \% + 56.13 \% + 270.28 \% + 3.90 \% - 3.22 \% \\
 E2 &= 5613 (=56.13 \%) & &= 359.49 \% \\
 E3 &= 27028 (=270.28 \%) \\
 P1 &= 390 (=3.90 \%) \\
 P2 &= 322 (=3.22 \%)
 \end{aligned}$$

Note:

Percentage values [%] mean, that the value is defined in percent with two decimal places.

For example: Value $12345_{IN} = 123.45 \% = 1.2345$

5.3.1.2 [331] Add. long A1=E1+E2-E3+P

	Par#	Type	Function		Par#	Type	Function	
E1	1344	Pos	positive Input E1	A1	1350	Pos	A = E1 + E2 - E3 + P	Low-word
E2	1345	Pos	positive Input E2	A2	1351	Pos		High-word
E3	1346	Pos	negative Input E3	P1	1348	Pos	Position-Offset P	Low-word
E4	1347	b	Master Reset	P2	1349	Pos		High-word

FT-instruction 1343 = "331 - Add. long A1 = E1 + E2 - E3 + P"

Description:

This function adds the inputs E1 and E2 und subtracts input E3. Additionally an offset can be set up using parameters P1 and P2.

$$A2 | A1 = E1 + E2 - E3 + P2 | P1 ;$$

$$A2 | A1 = \text{High - word} | \text{Low - word} ;$$

$$P2 | P1 = \text{High - word} | \text{Low - word}$$

The result (output) is split into a High-word (A1) and a Low-word (A2). The Position offset is divided as well in High-word (P1) and Low-word (P2).

As long as E4 (Master Reset) is TRUE, the output value A1 is set to 0.

Note:

The output value A2 is **not** the inverted value of A1.

The output A1 can be linked to other inputs for position values (long).

This function can also be used for ramp settings in configurations x40.

Example:

$$\begin{aligned}
 E1 &= 35468240 & A &= 35468240 + 5613 + 27028 + 270000 \\
 E2 &= 5613 & &= 35770881 \\
 E3 &= 27028 & &= 221D201_{\text{hex}} \\
 P &= 270000 = 41E0_{\text{hex}} & A1 &= D201_{\text{hex}} [= 53761] \\
 P1 &= 1E0_{\text{hex}} = 7856 & A2 &= 0221_{\text{hex}} [= 545] \\
 P2 &= 0004_{\text{hex}} = 4
 \end{aligned}$$

5.3.2 Multiplication

5.3.2.1 [332] Mult. (A1=E1*E2*P1)

	Par#	Type	Function		Par#	Type	Function
E1	1344	%	Input value 1	A1	1350	%	A1 = E1 × E2 × P1
E2	1345	%	Input value 2	A2	1351	%	inverted Output = -A1
E3	1346	-	-	P1	1348	%	Factor (Numerator)
E4	1347	b	Master Reset	P2	1349	-	-

FT-instruction 1343 = "332 - Mult. (A1=E1*E2*P1)"

Description:

This function multiplies the inputs E1 and E2 and the factor P1 with each other.

$$A1 = -A2 = E1 \times E2 \times P1$$

The result of the multiplication is limited to $\pm 327.67\%$.

As long as E4 (Master Reset) is TRUE, the output value A1 is set to 0.

Note:

$$100.00 \% * 100.00 \% = 100.00 \%$$

Example:

$$\begin{aligned} E1 &= 3240 (= 32.40 \%) & A1 &= 32.40 \% * 3.58 \% * 270.00 \% \\ E2 &= 7028 (= 3.58 \%) & &= 0.324 * 0.0358 * 2.70 \\ P1 &= 358 (= 270.00 \%) & &= 0.0313 = 3.13 \% \end{aligned}$$

Note:

Percentage values [%] mean, that the value is defined in percent with two decimal places.

For example: Value $12345_{IN} = 123.45 \% = 1.2345$

5.3.2.2 [333] Mult. w. result long (A=E1*E2*P1)

	Par#	Type	Function		Par#	Type	Function
E1	1344	%	positive Input E1	A1	1350	%	A = E1 × E2 × P1
E2	1345	%	positive Input E2	A2	1351	%	
E3	1346	-	-	P1	1348	%	Factor
E4	1347	b	Master Reset	P2	1349	-	-

FT-instruction 1343 = "333 - Mult. w. result long (A = E1 * E2 * P1)"

Description:

This function multiplies the inputs E1 and E2 and the factor P1 with each other.

The result (output) is split into a High-word (A1) and a Low-word (A2).

$$A2 | A1 = E1 \times E2 \times P1; \quad A2 | A1 = \text{High - word} | \text{Low - word}$$

The result of the multiplication (Long) is not limited.

As long as E4 (Master Reset) is TRUE, the output value A1 is set to 0.

Note:

The output value A2 is **not** the inverted value of A1.

The output A1 can be linked to other inputs for position values (long).

This function can also be used for ramp settings in configurations x40.

Example:

$$E1 = 24000 (=240.00 \%)$$

$$E2 = 31000 (=310.00 \%)$$

$$P1 = 63000 (=630.00 \%)$$

$$A = 240.00 \% * 310.00 \% * 630.00 \%$$

$$= (2.4000 * 3.1000 * 6.3000)$$

$$= 4687.20 \%$$

$$= 726F0_{\text{hex}}$$

$$A1 = 26F0_{\text{hex}} [=9968]$$

$$A2 = 0007_{\text{hex}} [= 7]$$

Note:

Percentage values [%] mean, that the value is defined in percent with two decimal places.

For example: Value $12345_{\text{IN}} = 123.45 \% = 1.2345$

5.3.2.3 [334] Mult. w. fraction (A1=E1*P1/P2)

	Par#	Type	Function		Par#	Type	Function
E1	1344	%	Input value 1	A1	1350	%	$A1 = E1 \times \frac{P1}{P2}$
E2	1345	-	-	A2	1351	%	inverted Output = -A1
E3	1346	-	-	P1	1348	%	Factor Numerator
E4	1347	b	Master Reset	P2	1349	%	Factor Denominator

FT-instruction 1343 = "334 - Mult. w. fraction (A1=E1*P1/P2)"

Description:

The input value E1 is multiplied with parameter value P1 and divided by parameter value P2.

$$A1 = -A2 = E1 \times \frac{P1}{P2}$$

The result of the multiplication is limited to $\pm 327.67 \%$.

As long as E4 (Master Reset) is TRUE, the output value A1 is set to 0.

Example:

$$E1 = 14000 (= 140.00 \%)$$

$$P1 = 15000 (= 150.00 \%)$$

$$P2 = 3233 (= 32.33 \%)$$

$$A1 = 140.00 \% * 150.00 \% / 32.33 \%$$

$$= (1.4000 * 1.5000 / 0.3233 = 6.4955)$$

$$= 649.55 \%$$

Note:

Percentage values [%] mean, that the value is defined in percent with two decimal places.

For example: Value $12345_{\text{IN}} = 123.45 \% = 1.2345$

If $P2 = 0$, A1 is set to $\pm 327.67 \%$. The sign is taken from the input value.

5.3.2.4 [335] Mult. long * Percent

	Par#	Type	Function		Par#	Type	Function
E1	1344			A1	1350		
E2	1345			A2	1351		
E3	1346			P1	1348		
E4	1347			P2	1349		

FT-instruction 1343 = "335 - Mult. long * Percent"

5.3.3 Division

5.3.3.1 [336] Div. A1=(E1/E2/E3)

	Par#	Type	Function		Par#	Type	Function
E1	1344	%	Input (Numerator)	A1	1350	%	$A1 = \frac{E1}{E2 \times E3}$
E2	1345	%	Input (Denominator 1)	A2	1351	%	inverted Output = -A1
E3	1346	%	Input (Denominator 2)	P1	1348	%	Upper limit
E4	1347	b	Master Reset	P2	1349	%	Lower limit

FT-instruction 1343 = "336 - Div. A1 =(E1/E2/E3)"

Description:

The input value E1 is divided by the product of input values E2 and E3.

$$A1 = -A2 = \frac{E1}{E2 \times E3}$$

The result of the division is limited to -P1 and +P1 (maximum of $\pm 327.67\%$).

As long as E4 (Master Reset) is TRUE, the output value A1 is set to 0.

The setting "9 - Zero" deactivates the inputs E2 and E3. If E2 (or E3) is deactivated, this value is not used for the division. It is handled like E2=1 (or E3=1).

Example:

$$\begin{aligned}
 E1 &= 14000 (=140.00\%) & A1 &= 140.00\% / 130.00\% / 32.33\% \\
 E2 &= 3000 (=30.00\%) & &= (1.4000 / 0.3000 / 0.3233) \\
 E3 &= 3233 (=32.33\%) & &= |14434.47\%| \text{ limit} \\
 & & &= 327.67\%
 \end{aligned}$$

Note:

Percentage values [%] mean, that the value is defined in percent with two decimal places.

For example: Value $12345_{IN} = 123.45\% = 1.2345$

If E2 =0 or E3 = 0, A1 is set to $\pm 327.67\%$. The sign is taken from the mathematical result of the other input values.

5.3.3.2 [337] Div. A1=(E1/P1)

	Par#	Type	Function		Par#	Type	Function
E1	1344	%	Input (Numerator)	A1	1350	%	$A1 = \frac{E1}{P1}$
E2	1345	-	-	A2	1351	%	inverted Output = -A1
E3	1346	-	-	P1	1348	%	Constant, used for division
E4	1347	b	Master Reset	P2	1349	%	Upper and lower limit

FT-instruction 1343 = "337 - Div. A1=(E1/P1)"

Description:

The input value E1 is divided by parameter value P1.

$$A1 = -A2 = \frac{E1}{P1}$$

The result of the division is limited to $\pm P2$ (maximum of $\pm 327.67\%$).

As long as E4 (Master Reset) is TRUE, the output value A1 is set to 0.

Example:

$$\begin{aligned}
 E1 &= 14000 \quad (= 140.00 \%) & A1 &= 140.00 \% / 40.00 \% \\
 P1 &= 4000 \quad (= 40.00 \%) & &= (1.4000 / 0.4000) \\
 & & &= |350.00 \%| \text{ limit} \\
 & & &= 327.67 \%
 \end{aligned}$$

Note:

Percentage values [%] mean, that the value is defined in percent with two decimal places.

For example: Value $12345_{IN} = 123.45 \% = 1.2345$

If $P1 = 0$, $A1$ is set to $\pm 327.67 \%$. The sign is taken from the input value.

5.3.3.3 [338] Div. $A1 = (P1/E1)$, reciprocal value

	Par#	Type	Function		Par#	Type	Function
E1	1344	%	Input (Denominator)	A1	1350	%	$A1 = \frac{P1}{E1}$
E2	1345	-	-	A2	1351	%	inverted Output = -A1
E3	1346	-	-	P1	1348	%	Constant (Numerator)
E4	1347	b	Master Reset	P2	1349	%	Upper and lower limit

FT-instruction 1343 = "338 - Div. $A1 = (P1/E1)$ "

Description:

The parameter value $P1$ is divided by input value $E1$ (reciprocal value).

$$A1 = -A2 = \frac{P1}{E1}$$

The result of the division is limited to $\pm P2$ (maximum of $\pm 327.67 \%$).

As long as $E4$ (Master Reset) is TRUE, the output value $A1$ is set to 0.

Example:

$$\begin{aligned}
 E1 &= 14000 \quad (= 140.00 \%) & A1 &= 40.00 \% / 140.00 \% \\
 P1 &= 4000 \quad (= 40.00 \%) & &= (0.4000 / 1.4000) \\
 & & &= 28.57 \%
 \end{aligned}$$

Note:

Percentage values [%] mean, that the value is defined in percent with two decimal places.

For example: Value $12345_{IN} = 123.45 \% = 1.2345$

If $E1 = 0$, $A1$ is set to $\pm 327.67 \%$. The sign is taken from the parameter value $P1$.

5.3.4 [339] Mult. & Div ($A1 = (E1 * E2) / E3$)

	Par#	Type	Function		Par#	Type	Function
E1	1344	%	Input (Numerator 1)	A1	1350	%	$A1 = \frac{E1 * E2}{E3}$
E2	1345	%	Input (Numerator 2)	A2	1351	%	inverted Output = -A1
E3	1346	%	Input (Denominator)	P1	1348	%	Upper limit
E4	1347	b	Master Reset	P2	1349	%	Lower limit

FT-instruction 1343 = "339 - Mult. & Div ($A1 = (E1 * E2) / E3$)"

Description:

The input value $E1$ is multiplied with input value $E2$ and divided by input value $E3$.

$$A1 = -A2 = \frac{E1 * E2}{E3}$$

The result of the operation is limited to $\pm P2$ (maximum of $\pm 327.67 \%$).

As long as $E4$ (Master Reset) is TRUE, the output value $A1$ is set to 0.

Example:

$$\begin{aligned}
 E1 &= 14000 \text{ (= 140.00 \%)} & A1 &= 140.00 \% * 40.00 \% / 20.00 \% \\
 E2 &= 4000 \text{ (= 40.00 \%)} & &= (1.4000 * 0.4000 / 0.2000) \\
 E3 &= 2000 \text{ (= 20.00 \%)} & &= 280.00 \%
 \end{aligned}$$

Note:

Percentage values [%] mean, that the value is defined in percent with two decimal places.
 For example: Value $12345_{IN} = 123.45 \% = 1.2345$

5.3.5 [340] Average function

	Par#	Type	Function		Par#	Type	Function
E1	1344	%	Input 1	A1	1350	%	$A1 = \frac{E1 + E2 + E3}{3} \times \frac{P1}{P2}$
E2	1345	%	Input 2	A2	1351	%	inverted Output = -A1
E3	1346	%	Input 3	P1	1348	i	Factor Numerator
E4	1347	b	Master Reset	P2	1349	i	Factor Denominator

FT-instruction 1343 = "340 - Average function"

Description:

The average value of the input values E1, E2 and E3 is calculated.
 Parameter values P1 and P2 can be used as a "correction factor" if necessary.

$$A1 = -A2 = \frac{E1 + E2 + E3}{3} \times \frac{P1}{P2}$$

The correction factor should not be set to a bigger value than 10922.

As long as E4 (Master Reset) is TRUE, the output value A1 is set to 0.

Example:

$$\begin{aligned}
 E1 &= 14000 \text{ (= 140.00 \%)} & A1 &= (140.00 \% + 40.00 \% + 20.00 \%) / 3 * 5/4 \\
 E2 &= 4000 \text{ (= 40.00 \%)} & &= 200 \% / 3 * 5/4 \\
 E3 &= 2000 \text{ (= 20.00 \%)} & &= 83.33 \% \\
 P1 &= 5 \\
 P2 &= 4
 \end{aligned}$$

Note:

Percentage values [%] mean, that the value is defined in percent with two decimal places.
 For example: Value $12345_{IN} = 123.45 \% = 1.2345$

5.3.6 [341] Value of two orthogonal components

	Par#	Type	Function		Par#	Type	Function
E1	1344	%	Input value 1	A1	1350	%	$A1 = \sqrt{E1^2 + E2^2} \times \frac{P1}{P2}$
E2	1345	%	Input value 2	A2	1351	%	inverted Output = -A1
E3	1346	-	-	P1	1348	%	Constant (Numerator)
E4	1347	b	Master Reset	P2	1349	%	Constant (Denominator)

FT-instruction 1343 = "341 - Value of two orthogonal components"

Description:

The orthogonal (perpendicular) input values E1 and E2 are used to calculate the absolute value.

The result is multiplied with the constant $\frac{P1}{P2}$.

$$A1 = -A2 = \sqrt{E1^2 + E2^2} \times \frac{P1}{P2}$$

As long as E4 (Master Reset) is TRUE, the output value A1 is set to 0.

Example:

$$\begin{aligned}
 E1 &= 14000 \text{ (= 140.00 \%)} & A1 &= \text{SQRT}(140.00 \%^2 + 40.00^2) * 5.00 \% / 100.00 \% \\
 E2 &= 4000 \text{ (= 40.00 \%)} & &= 212.00 \% * 5.00 \% / 100.00 \% \\
 P1 &= 500 \text{ (= 5.00 \%)} & &= 10.60 \% \\
 P2 &= 10000 \text{ (= 100.00 \%)} & &
 \end{aligned}$$

Note:

Percentage values [%] mean, that the value is defined in percent with two decimal places.
 For example: Value 12345_{IN} = 123.45 % = 1.2345

5.3.7 [342] Value of three orthogonal components

	Par#	Type	Function		Par#	Type	Function
E1	1344	%	Input value 1	A1	1350	%	$A1 = \sqrt{E1^2 + E2^2 + E3^2} \times \frac{P1}{P2}$
E2	1345	%	Input value 2	A2	1351	%	inverted Output = -A1
E3	1346	%	Input value 3	P1	1348	%	Constant (Numerator)
E4	1347	b	Master Reset	P2	1349	%	Constant (Denominator)

FT-instruction 1343 = „342 - Value of three orthogonal components“

Description:

The orthogonal (perpendicular) input values E1, E2 and E3 are used to calculate the absolute value.

The result is multiplied with the constant $\frac{P1}{P2}$.

$$A1 = -A2 = \sqrt{E1^2 + E2^2 + E3^2} \times \frac{P1}{P2}$$

As long as E4 (Master Reset) is TRUE, the output value A1 is set to 0.

Example:

$$\begin{aligned}
 E1 &= 14000 \text{ (= 140.00 \%)} & A1 &= \text{SQRT}(140.00 \%^2 + 40.00 \%^2 + 30.00 \%^2) * 5.00 \% / \\
 E2 &= 4000 \text{ (= 40.00 \%)} & &100.00 \% \\
 E3 &= 3000 \text{ (= 30.00 \%)} & &= 221.00 \% * 5.00 \% / 100.00 \% \\
 P1 &= 500 \text{ (= 5.00 \%)} & &= 11,05 \% \\
 P2 &= 10000 \text{ (= 100.00 \%)} & &
 \end{aligned}$$

Note:

Percentage values [%] mean, that the value is defined in percent with two decimal places.
 For example: Value 12345_{IN} = 123.45 % = 1.2345

5.3.8 [350] Integrator (A1=Int(E1 * dt))

	Par#	Type	Function		Par#	Type	Function
E1	1344	%	Integration value	A1	1350	%	$A1 = \frac{1}{P1} \int E1 dt + E2$
E2	1345	%	Start Value	A2	1351	%	inverted Output = -A1
E3	1346	b	Master Set	P1	1348	%	Integration time in ms (Denominator)
E4	1347	b	Master Reset	P2	1349	-	-

FT-instruction 1343 = „350 - Integrator (A1 = Int(E1 * dt))“

Description:

The input value E1 is integrated.

The integration time P1 specifies how long it takes for the output value with a constant input to reach the input value.

$$A1 = -A2 = \frac{1}{P1} \int E1 dt + E2$$

If the integrator should be put on hold, the input E2 has to be linked with the output and the master-set input (E3) has to be activated.

Master Set: TRUE sets the Integrator to the Start value (E2). The start value can be specified with input E2.

Master-Reset: TRUE sets the integrator to 0.

Master-Reset has a higher priority than Master-Set.

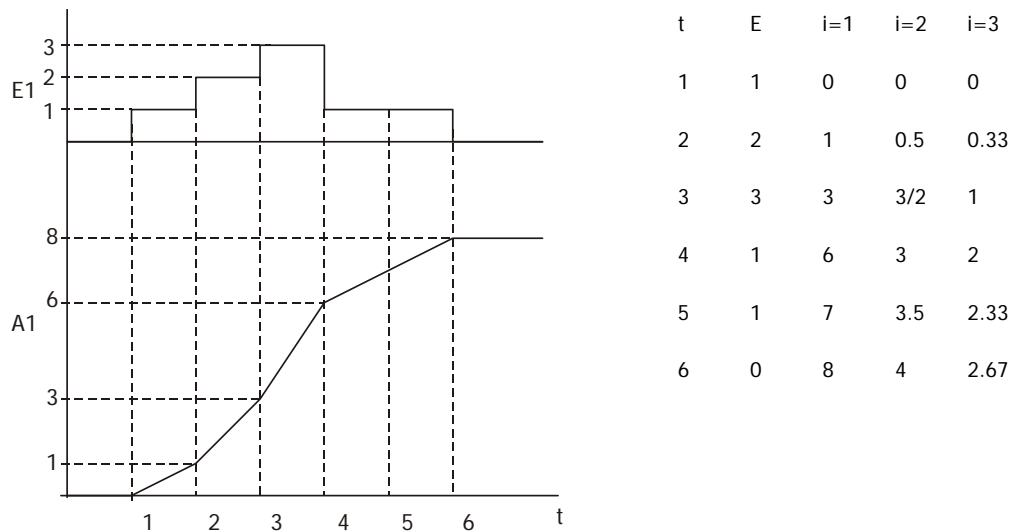
**Note:**

Percentage values [%] mean, that the value is defined in percent with two decimal places.

For example: Value 12345_{IN} = 123.45 % = 1.2345

5.3.9 [351] Differentiator (D-Element) (A1=dE1/dt)

	Par#	Type	Function
E1	1344	%	Differentiation value
E2	1345	-	-
E3	1346	-	-
E4	1347	b	Master Reset

	Par#	Type	Function
A1	1350	%	$A1 = \frac{1}{P1} \times \frac{dE1}{dt}$
A2	1351	%	inverted output = -A1
P1	1348	%	Rate time in ms
P2	1349	-	-

FT-instruction 1343 = "351 - Differentiator (D-Element) (A1=dE1/dt)"

Description:

The input value E1 is differentiated.

The rate time specifies, how long a ramp has to rise until it has the same value as the output of the differentiator.

$$A1 = -A2 = \frac{1}{P1} \times \frac{dE1}{dt}$$

If an integrator and a differentiator are connected in a row, the result is a P-part with the amplification $V = Td/Ti$.

If, in example, a step function is limited at the input, the output value is set for a corresponding longer time.

A step function at the input is assumed with the ramp rise = step height/sampling time.

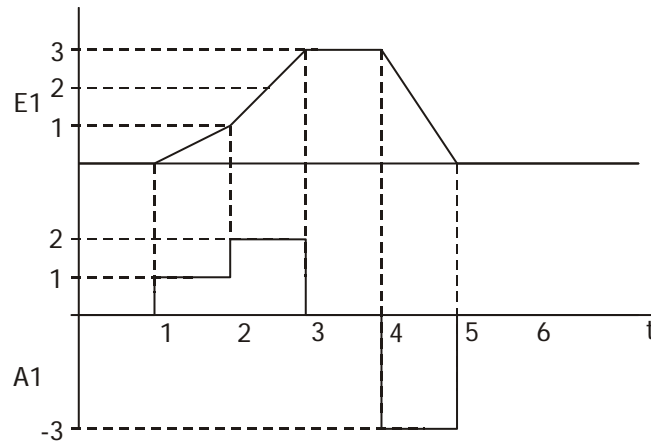

As long as E4 (Master Reset) is TRUE, the output value A1 is set to 0.

Note:

Percentage values [%] mean, that the value is defined in percent with two decimal places.
 For example: Value $12345_{IN} = 123.45 \% = 1.2345$

5.3.10 [360] Absolute Value

	Par#	Type	Function
E1	1344	%	Input value
E2	1345	-	-
E3	1346	-	-
E4	1347	b	Master Reset

	Par#	Type	Function
A1	1350	%	$A1 = E1 $
A2	1351	%	inverted output = -A1
P1	1348	-	-
P2	1349	-	-

FT-instruction 1343 = „360 - Absolute Value“

Description:

The absolute value of the input value E1 is determined. The output value A1 is always positive.
 $A1 = -A2 = |E1|$

As long as E4 (Master Reset) is TRUE, the output value A1 is set to 0.

Note:

Percentage values [%] mean, that the value is defined in percent with two decimal places.
 For example: Value $12345_{IN} = 123.45 \% = 1.2345$

5.3.11 [361] X²

	Par#	Type	Function
E1	1344	%	Input value
E2	1345	-	-
E3	1346	-	-
E4	1347	b	Master Reset

	Par#	Type	Function
A1	1350	%	$A1 = E1^2$
A2	1351	%	inverted Output = -A1
P1	1348	-	-
P2	1349	%	Limit of output value

FT-instruction 1343 = „361 - X²“

Description:

Input value E1 is multiplied with itself.
 $A1 = -A2 = E1^2$

Example: $E1 = 130.00\%$; $A1 = E1^2 = 169.00\%$

The output value is limited to P2.

As long as E4 (Master Reset) is TRUE, the output value A1 is set to 0.

Note:

Percentage values [%] mean, that the value is defined in percent with two decimal places.
For example: Value $12345_{IN} = 123.45 \% = 1.2345$

5.3.12 [362] X³

	Par#	Type	Function
E1	1344	%	Input value
E2	1345	-	-
E3	1346	-	-
E4	1347	b	Master Reset

	Par#	Type	Function
A1	1350	%	$A1 = E1^3$
A2	1351	%	inverted Output = -A1
P1	1348	-	-
P2	1349	%	Limit of output value

FT-instruction 1343 = „362 - X³“

Description:

The input value E1 is raised to the power of 3.

$$A1 = -A2 = E1^3$$

Example: $E1 = 130.00\%$; $A1 = E1^3 = 219.70\%$

The output value is limited to $\pm P2$.

As long as E4 (Master Reset) is TRUE, the output value A1 is set to 0.

Note:

Percentage values [%] mean, that the value is defined in percent with two decimal places.
For example: Value $12345_{IN} = 123.45 \% = 1.2345$

5.3.13 [363] \sqrt{X}

	Par#	Type	Function
E1	1344	%	Input value
E2	1345	-	-
E3	1346	-	-
E4	1347	b	Master Reset

	Par#	Type	Function
A1	1350	%	$A1 = \sqrt{E1}$
A2	1351	%	inverted Output = -A1
P1	1348	-	-
P2	1349	%	Limit of output value

FT-instruction 1343 = „363 - SQRT(x)“

Description:

The square root of input value E1 is calculated.

$$A1 = -A2 = \sqrt{E1}$$

Note:

The square root of a negative number doesn't give a real result. Before the operation the algebraic sign is determined and transferred to the output result A1.

$$A1 = \sqrt{|E1|}; \quad \begin{array}{l} +E1 \Rightarrow A1 = +\sqrt{|E1|} \\ -E1 \Rightarrow A1 = -\sqrt{|E1|} \end{array}$$

Example: Positive Input value
Negative Input value

$E1 = 130.00\%$
 $E1 = -130.00\%$

$A1 = 114.02\%$
 $A1 = -114.02\%$

The output value is limited to $\pm P2$.

As long as E4 (Master Reset) is TRUE, the output value A1 is set to 0.

Note:

Percentage values [%] mean, that the value is defined in percent with two decimal places.
For example: Displayed Value $12345_{IN} = 123.45 \% = 1.2345$

5.4 Controller

Note:

Controller can be combined through separate elements. This can be used to limit output values of single elements.

5.4.1 [370] P-Controller

	Par#	Type	Function		Par#	Type	Function
E1	1344	%	Input (Reference Value)	A1	1350	%	$A1 = P1 \times (E1 - E2)$
E2	1345	%	Input (Actual Value)	A2	1351	%	inverted Output = -A1
E3	1346	-	-	P1	1348	i	P-Amplification (x.xx)
E4	1347	b	Master Reset	P2	1349	%	Limit of output value

FT-instruction 1343 = „370 - P-Controller“

Description:

The control deviation ($E1 - E2$) is multiplied with the amplification P1.

$$A1 = -A2 = P1 \times (E1 - E2)$$

The output value is limited to $\pm P2$.

As long as E4 (Master Reset) is TRUE, the output value A1 is set to 0.

Note:

Percentage values [%] mean, that the value is defined in percent with two decimal places.

For example: Displayed Value $12345_{IN} =$ function value $123.45 \% = 1.2345$

The amplification is entered with two decimal places:

→ displayed value 123 = function value 1.23

5.4.2 [371] PI-Controller (Tn in milliseconds)

	Par#	Type	Function		Par#	Type	Function
E1	1344	%	Input (Reference value)	A1	1350	%	$A1 = P1 \times (E1 - E2) + \frac{P1}{P2} \int (E1 - E2) dt$
E2	1345	%	Input (Actual value)	A2	1351	%	inverted output = -A1
E3	1346	%	Limit of the Output values	P1	1348	i	P-Amplification
E4	1347	b	Master Reset	P2	1349	i	Reset time in ms

FT-instruction 1343 = „371 - PI-Controller (Tn in milliseconds)“

Description:

The control deviation ($E1 - E2$) is multiplied with the amplification P1. The I-Controller sums up the control deviation by time. The I-part is summed up. After the reset time has elapsed, the I-part reaches the same value additional, so the output value doubles.

$$A1 = -A2 = P1 \times (E1 - E2) + \frac{P1}{P2} \int (E1 - E2) dt$$

The output value is limited to input value E3.

As long as E4 (Master Reset) is TRUE, the output value A1 and the I-part is set to 0.

Note:

Percentage values [%] mean, that the value is defined in percent with two decimal places.

For example: Value $12345_{IN} = 123.45 \% = 1.2345$

5.4.3 [372] PI-Controller (Tn in seconds)

	Par#	Type	Function		Par#	Type	Function
E1	1344	%	Input (Reference value)	A1	1350	%	$A1 = P1 \times (E1 - E2) + \frac{P1}{P2} \int (E1 - E2) dt$
E2	1345	%	Input (Actual value)	A2	1351	%	inverted Output = -A1
E3	1346	%	Limit of the Output values	P1	1348	i	P-Amplification
E4	1347	b	Master Reset	P2	1349	i	Reset time in s

FT-instruction 1343 = „372 - PI-Controller (Tn in seconds)“

Description:

The control deviation (E1 – E2) is multiplied with the amplification P1. The I-Controller sums up the control deviation by time. The I-part is summed up. After the reset time has elapsed, the I-part reaches the same value additional, so the output value doubles.

$$A1 = -A2 = P1 \times (E1 - E2) + \frac{P1}{P2} \int (E1 - E2) dt$$

The output value is limited to input value E3.

As long as E4 (Master Reset) is TRUE, the output value A1 and the I-part is set to 0.

Note:

Percentage values [%] mean, that the value is defined in percent with two decimal places. For example: Value 12345_{IN} = 123.45 % = 1.2345

5.4.4 [373] PD(T1)-Controller

	Par#	Type	Function		Par#	Type	Function
E1	1344	%	Input (Reference value)	A1	1350	%	$A1 = P1 \times (E1 - E2) + P1 \times P2 \times \frac{d(E1 - E2)}{dt}$
E2	1345	%	Input (Actual value)	A2	1351	%	inverted Output = -A1
E3	1346	%	Limit of the Output values	P1	1348	i	Amplification
E4	1347	b	Master Reset	P2	1349	i	Reset time in ms

FT-instruction 1343 = „373 - PD(T1)-Controller“

Description:

The control deviation (E1 – E2) is multiplied with the amplification P1. The D-part is summed up.

$$A1 = -A2 = P1 \times (E1 - E2) + P1 \times P2 \times \frac{d(E1 - E2)}{dt}$$

The output value is limited to input value E3.

The Input value can in example be linked to a fixed value.

As long as E4 (Master Reset) is TRUE, the output value A1 is set to 0.

The time constant T1 of the PD(T1)-Controller corresponds to the sampling time.

Note:

Percentage values [%] mean, that the value is defined in percent with two decimal places. For example: Value 12345_{IN} = 123.45 % = 1.2345

5.4.5 [374] PID(T1)-Controller (Tn in milliseconds)

	Par#	Type	Function		Par#	Type	Function
E1	1344	%	Input (Reference value)	A1	1350	%	$A1 = P1 \times (E1 - E2) + \frac{P1}{P2} \int (E1 - E2) dt + P1 \times P2 \times \frac{d(E1 - E2)}{dt}$
E2	1345	%	Input (Actual value)	A2	1351	%	inverted Output = -A1
E3	1346	%	Limit of the Output values	P1	1348	i	Reset time in ms
E4	1347	b	Master Reset	P2	1349	i	Rate time in ms

FT-instruction 1343 = „374 - PID(T1)-Controller (Tn in milliseconds)“

Description:

The control deviation (E1 – E2) is multiplied with the amplification =1. I-part and D-part are summed up.

$$A1 = -A2 = P1 \times (E1 - E2) + \frac{P1}{P2} \int (E1 - E2) dt + P1 \times P2 \times \frac{d(E1 - E2)}{dt}$$

In operation mode „374 PID(T1)-Controller“ the amplification P1 (I-part) and the rate time P2 (D-part) can be adjusted. The Amplification P1 is set to the fixed value 1. To use a different Amplification, a P-Controller (operation mode „370 - P-Controller“) has to be linked with the input of the PID(T1)-Controller.

Note:

The P-Controller (operation mode 370) uses P1 for amplification. The PID(T1)-Controller uses P1 for the reset time.

PID-Controller and prior connected P-Controller to set up an amplification:

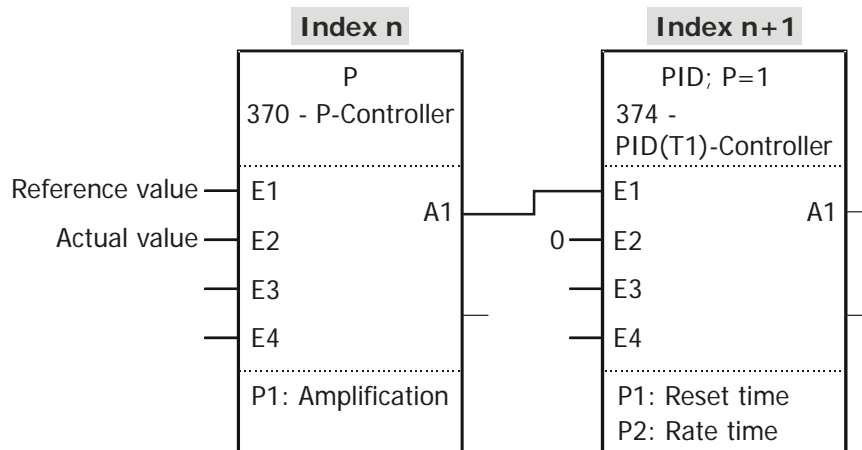

Index n:

$$A1 = -A2 = P1 \times (E1 - E2) +$$

Index n+1:

$$\frac{P1}{P2} \int (E1 - E2) dt + P1 \times P2 \times \frac{d(E1 - E2)}{dt}$$

- Set up the amplification in the P-Controller.
- Set up the reset time and rate time in the PID-Controller.

Note:

If the amplification of the PID-Controllers = 1 is used, no additional P-Controller is necessary.

If a step function with 100.00% at the input is set, the output sums up in three parts:

- P-part: 100.00% constant
- I-part: Ramp, which reaches the value of 100.00 % with the reset time
- D-part: Impulse of the length of a sample step and the height

$$\frac{P2}{T1} \times 100\%; \quad T1 = \text{Sampletime}$$

If the height exceeds the limits of the output value, the impulse is put out for a corresponding longer time.

The output value is limited to input value E3.

The Input value can in example be linked to a fixed value.

As long as E4 (Master Reset) is TRUE, the output value A1 and the I-part is set to 0.

Note:

Percentage values [%] mean, that the value is defined in percent with two decimal places.

For example: Value $12345_{IN} = 123.45 \% = 1.2345$

5.4.6 [375] PID(T1)-Controller (Tn in seconds)

	Par#	Type	Function		Par#	Type	Function
E1	1344	%	Input (Reference value)	A1	1350	%	$A1 = P1 \times (E1 - E2) + \frac{P1}{P2} \int (E1 - E2) dt + P1 \times P2 \times \frac{d(E1 - E2)}{dt}$
E2	1345	%	Input (Actual value)	A2	1351	%	inverted Output = -A1
E3	1346	%	Limit of the Output values	P1	1348	i	Reset time in s
E4	1347	b	Master Reset	P2	1349	i	Rate time in ms

FT-instruction 1343 = „375 – PID(T1)-Controller (Tn in seconds)“

Description:

The control deviation (E1 – E2) is multiplied with the amplification =1. The I-part and D-part are summed up.

$$A1 = -A2 = P1 \times (E1 - E2) + \frac{P1}{P2} \int (E1 - E2) dt + P1 \times P2 \times \frac{d(E1 - E2)}{dt}$$

In operation mode „375 PID(T1)-Controller“ the amplification P1 (I-part) and the rate time P2 (D-part) can be adjusted. The amplification P1 is set to the fixed value 1. To use a different amplification, a P-Controller (operation mode „370 - P-Controller“) has to be linked with the input of the PID(T1)-Controller.

Note:

The P-Controller (operation mode 370) uses P1 for amplification.

The PID(T1)-Controller uses P1 for the reset time.

PID-Controller and prior connected P-Controller to set up an amplification:

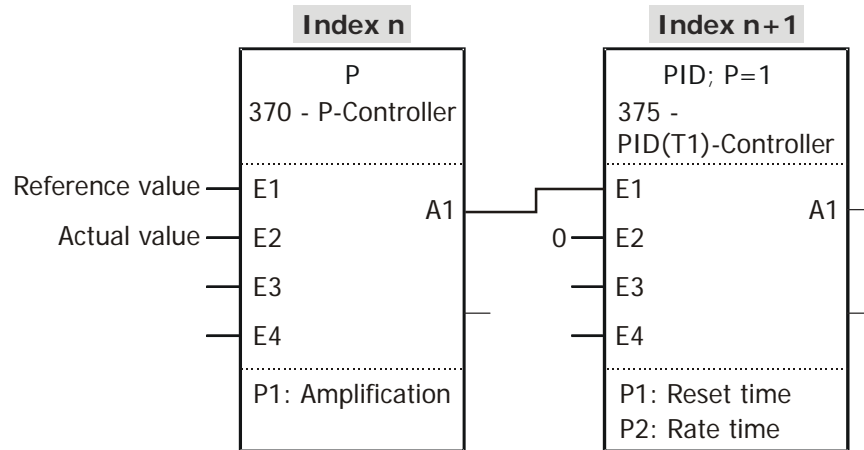

Index n: $A1 = -A2 = P1 \times (E1 - E2)$

Index n+1: $\frac{P1}{P2} \int (E1 - E2) dt + P1 \times P2 \times \frac{d(E1 - E2)}{dt}$

- Set up the amplification in the P-Controller.
- Set up the reset time and rate time in the PID-Controller.

Note:

If the amplification of the PID-Controllers = 1 is used, no additional P-Controller is necessary.

If a step function with 100.00% at the input is set, the output sums up in three parts:

- P-part: 100.00% constant
- I-part: Ramp, which reaches the value of 100.00 % with the reset time
- D-part: Impulse of the length of a sample step and the height

$$\frac{P2}{T1} \times 100\%; \quad T1 = \text{Sampletime}$$

If the height exceeds the limits of the output value, the impulse is put out for a corresponding longer time.

The output value is limited to input value E3.

The Input value can in example be linked to a fixed value.

As long as E4 (Master Reset) is TRUE, the output value A1 and the I-part is set to 0.

Note:

Percentage values [%] mean, that the value is defined in percent with two decimal places.

For example: Value $12345_{IN} = 123.45 \% = 1.2345$

5.5 Filter

5.5.1 [380] PT1-element

	Par#	Type	Function
E1	1344	%	Input value
E2	1345	%	Start value
E3	1346	b	Master Set
E4	1347	b	Master Reset

	Par#	Type	Function
A1	1350	%	$A1 = E1 \times (1 - e^{-\frac{t}{P1}})$
A2	1351	%	inverted output = -A1
P1	1348	i	Filter time constant in ms
P2	1349	-	-

FT-instruction **1343** = „380 - PT1-element“

Description:

The input value E1 is filtered.

$$A1 = -A2 = E1 \times (1 - e^{-\frac{t}{P1}})$$

- The filter time constant P1 specifies, how long it takes with a constant input value to reach 63% of the input value at the output (starting from zero).
- Master Set: TRUE sets the output to the Start value. The Start value can be defined by input E2.
- Master-Reset: TRUE sets the output to 0.
- Master-Reset has a higher priority than Master-Set.

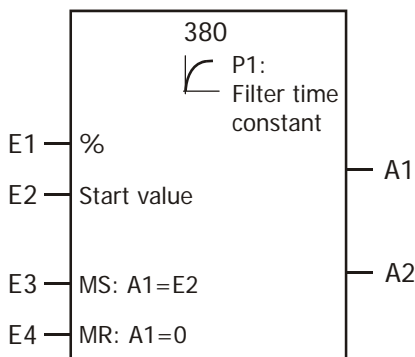
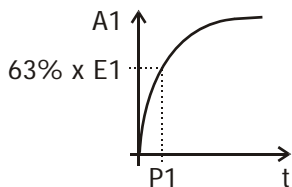

To set the filter to hold, the input 2 of the output has to be linked with the output and the Master Set input E3 has to be set to TRUE.

$E2=A1, E3=TRUE$

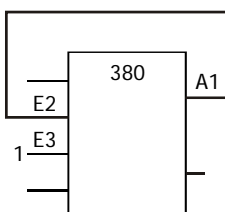

Note:

Percentage values [%] mean, that the value is defined in percent with two decimal places.

For example: Value $12345_{IN} = 123.45 \% = 1.2345$

5.5.2 [381] Time average

	Par#	Type	Function
E1	1344	%	Input value
E2	1345	-	-
E3	1346	-	-
E4	1347	b	Master Reset

	Par#	Type	Function
A1	1350	%	$A1 = \frac{\sum_{i=1}^n E1_i}{n} = \frac{E1_1 + E1_2 + E1_3 + \dots + E1_n}{n}$
A2	1351	%	inverted Output = -A1
P1	1348	-	-
P2	1349	-	-

FT-instruction 1343 = "381 - Time average"

Description:

- The function determines the average value over an elapsed time. The output value is updated with every passed cycle.
- If Master Reset = FALSE: The output value is the average value of all input values since the last negative edge was set on Master Reset.
- If Master Reset = TRUE: The outputs value is set to the input value.

$$A1 = -A2 = \frac{\sum_{i=1}^n E1i}{n} = \frac{E1_1 + E1_2 + E1_3 + \dots + E1_n}{n}$$

E4	A1=
0	Average value of E1
1	E4

Note:

Percentage values [%] mean, that the value is defined in percent with two decimal places. For example: Value 12345_{IN} = 123.45 % = 1.2345

5.5.3 [382] Ramp limiter

	Par#	Type	Function		Par#	Type	Function
E1	1344	%	Input value	A1	1350	%	E1 with limited ramp rise
E2	1345	%	Start value	A2	1351	%	inverted Output = -A1
E3	1346	b	Master Set	P1	1348	%	Ramp rise [% per time unit]
E4	1347	b	Master Reset	P2	1349	i	Time unit 1: [ms], 2: [s], 3: [min]

FT-instruction 1343 = "382 - Ramp limiter"

Description:

The output value follows the input value with a limited ramp rise.

- P1 defines the value in percent, that the output value changes as a maximum.
- P2 defines, which unit P1 is specified:
 - 1: in Percent per Millisecond [%/ms],
 - 2: in Percent per Second [%/s],
 - 3: in Percent per Minute [%/min].
- Master Set: TRUE sets the output to the Start value. The Start value can be defined by input E2.
- Master-Reset: TRUE sets the output A1 to 0.
- Master-Reset has a higher priority than Master-Set.

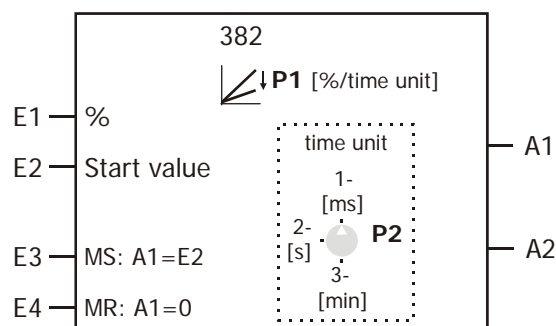

E3	E4	A1=	
0	0	E1	(ramp rise limited)
0→1	0	E2	
x	0→1	0	

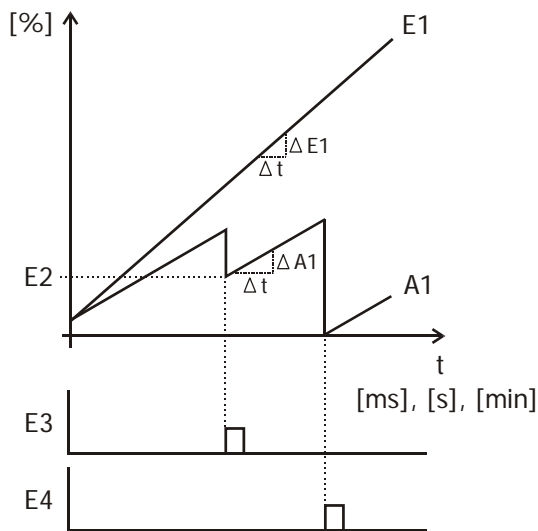

To stop the ramp, the input 2 has to be linked to the output and the Master-Set-Input (E3) has to be set.

$E2=A1$, $E3=TRUE$

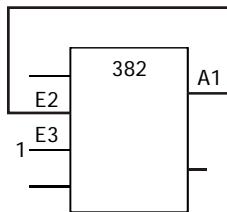

Note:

Percentage values [%] mean, that the value is defined in percent with two decimal places.
For example: Value $12345_{IN} = 123.45 \% = 1.2345$

5.5.4 [383] Spike-Filter (Middle of three)

	Par#	Type	Function		Par#	Type	Function
E1	1344	%	Input value	A1	1350	%	$A1 = \frac{E1_{(tn-2)} + E1_{(tn-1)} + E1_{(tn)}}{3}$
E2	1345	%	Start value	A2	1351	%	inverted Output = -A1
E3	1346	b	Master Set	P1	1348	-	-
E4	1347	b	Master Reset	P2	1349	-	-

FT-instruction 1343 = "383 - Spike-Filter (Middle of three)"

Description:

The input value E1 is filtered.

The average value of the current input value and the two prior input values is set to the output. This way, single peaks are suppressed.

$$A1 = -A2 = \frac{E1_{(tn-2)} + E1_{(tn-1)} + E1_{(tn)}}{3}$$

- Master Set: TRUE sets the output to the Start value. The Start value can be defined by input E2.
- Master-Reset: TRUE sets the output to 0.
- Master-Reset has a higher priority than Master-Set.

E3	E4	A1=	
0	0	E1	(Average value of last 3 values)
0→1	0	E2	
x	0→1	0	

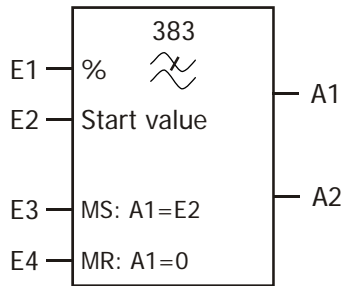

Note:

Percentage values [%] mean, that the value is defined in percent with two decimal places.
 For example: Value 12345_{IN} = 123.45 % = 1.2345

5.6 Analog switches

5.6.1 [390] Analogue Multiplexer (data set no.)

	Par#	Type	Function
E1	1344	%	Input value 1
E2	1345	%	Input value 2
E3	1346	%	Input value 3
E4	1347	%	Input value 4

	Par#	Type	Function
A1	1350	%	E1, E2, E3 or E4
A2	1351	%	inverted Output = -A1
P1	1348	-	-
P2	1349	-	-

FT-instruction **1343** = "390 - Analogue Multiplexer (data set no.)"

Description:

Depending on the current data set (parameter *active data set* **249**) one of the inputs value is set to the output.

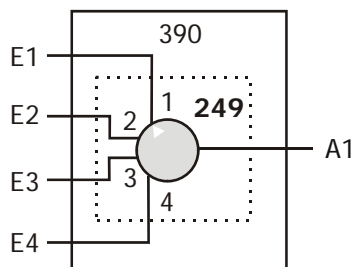

<i>Active data set</i> 249	A1=
1	E1
2	E2
3	E3
4	E4

Note:

Percentage values [%] mean, that the value is defined in percent with two decimal places.
 For example: Value 12345_{IN} = 123.45 % = 1.2345

5.6.2 [391] Analog Switch

	Par#	Type	Function
E1	1344	%	Input value 1
E2	1345	%	Input value 2
E3	1346	b	Selection of value 1 or value 2
E4	1347	b	Selection of E or P

	Par#	Type	Function
A1	1350	%	E1, E2, P1 or P2
A2	1351	%	inverted Output = -A1
P1	1348	%	Fixed value 1
P2	1349	%	Fixed value 2

FT-instruction **1343** = "391 - Analog Switch"

Description:

One of the values E1, E2, P1 or P2 is set to the output. Via E4 you can make the selection, if an input value (E1, E2) or a fixed value (P1, P2) is set to the output. Via E3 you can make the selection to use value 1 or 2.

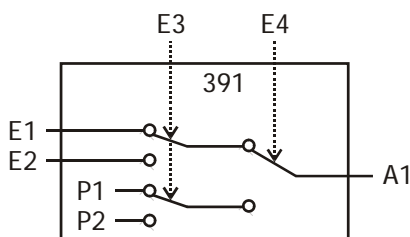

The output value is summarized in the following table according to the input values:

E3	E4	A1=
0	0	E1
1	0	E2
0	1	P1
1	1	P2

Note:

Percentage values [%] mean, that the value is defined in percent with two decimal places.
For example: Value $12345_{IN} = 123.45 \% = 1.2345$

5.6.3 [392] MUX for position values (data set no.), Multiplexer

	Par#	Type	Function
E1	1344	Pos.	Input value 1
E2	1345	Pos.	Input value 2
E3	1346	Pos.	Input value 3
E4	1347	Pos.	Input value 4

	Par#	Type	Function
A1	1350	Pos.	E1, E2, E3 or E4
A2	1351	Pos.	
P1	1348	-	-
P2	1349	-	-

FT-instruction **1343** = "392 - MUX for position values (data set no.)"

Description:

Depending on the current data set (parameter *active data set* **249**) one of the input values is set to the output.

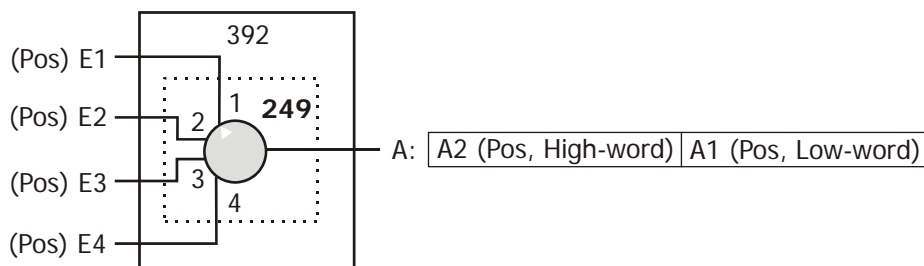

Active data set 249	A1=
1	E1
2	E2
3	E3
4	E4

A = A2 | A1 = High – word | Low – word

Note:

The output value A2 is **not** the inverted value of A1.

The output A1 can be linked to other inputs for position values (long).

This function can also be used for ramp settings in configurations x40.

If an input is linked with FALSE, the output is set to “0” if the active data set selects this input.

5.6.4 [393] Switch for position values

	Par#	Type	Function
E1	1344	Pos	Input value 1
E2	1345	Pos	Input value 2
E3	1346	b	Selection value 1 or 2
E4	1347	b	Selection of E or P

	Par#	Type	Function
A1	1350	Pos	E1, E2 or (P2 P1)
A2	1351	Pos	
P1	1348	Pos	Fixed value P
P2	1349	Pos	

FT-instruction **1343** = “393 - Switch for position values”

Description:

One of the values E1, E2 or P is set to the output. Via E4 you can make the selection, if an input value or the fixed value is set. Via E3 you can make the selection to use value 1 or 2.

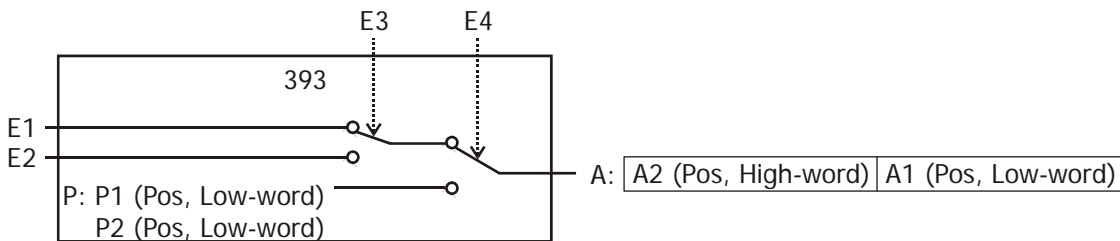

The output value is summarized in the following table according to the input values:

E3	E4	A1=
0	0	E1
1	0	E2
x	1	P2 P1

P2 | P1 = High – word | Low – word

Note:

The output value A2 is **not** the inverted value of A1.

The output A1 can be linked to other inputs for position values (long).

This function can also be used for ramp settings in configurations x40.

5.7 Parameter access

5.7.1 Write parameter

The function table can modify parameters of the inverter. This happens in two steps:

- The function table makes an entry for a write command into a list with all relevant data.
- The No-Real time system processes this list. Multiple write commands on the same parameter are deleted. The list can contain up to 8 write accesses.

The Output is set to TRUE, if the List is full and no further write accesses can be added.

If the parameter number lies outside the range (0 ... 1599), only the state of the buffer is checked and the output is set, if necessary.

Occurring faults during the write access are ignored.

If "Wait" input E4 = TRUE, the list for the write commands is considered and as long as the buffer is full, the write command writes a "NOP (No operation)" instead of the intended write command to the list and add the intended write command to the list as soon as possible.

If "Wait" input E4 = FALSE, write accesses can get lost if the buffer has an overflow.

If the "Delete buffer" input E2 = TRUE, the buffer is deleted before adding the new write command.

The target parameter of the write command is specified by P1. The target data set is specified by P2.

5.7.1.1 [401] Write frequency parameter

	Par#	Type	Function		Par#	Type	Function
E1	1344	%	Input value 1	A1	1350	b	E1[Hz]
E2	1345	b	Delete buffer	A2	1351	b	inverted Output = -A1
E3	1346	b	Write enable	P1	1348	i	Parameter number
E4	1347	b	Wait until Writing complete	P2	1349	i	Data set (0 ... 9)/Index

FT-instruction 1343 = „401 - Write frequency parameter“

Description:

The input value is converted from percent into Hz and written as long-Parameter.

E1 [%] → E1 [Hz]

123.45 % = 123.45 Hz

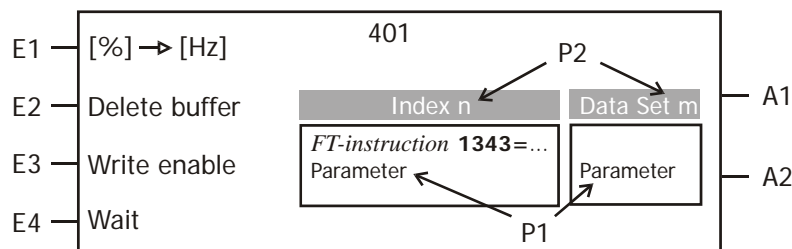

5.7.1.2 [402] Write current parameter

	Par#	Type	Function		Par#	Type	Function
E1	1344	%	Input value 1	A1	1350	b	E1[A]
E2	1345	b	Delete buffer	A2	1351	b	inverted Output = -A1
E3	1346	b	Write enable	P1	1348	i	Parameter number
E4	1347	b	Wait until Writing complete	P2	1349	i	Data set (0 ... 9)/Index

FT-instruction 1343 = „402 - Write current parameter“

Description:

The input value is converted from percent into Ampere and written as int-Parameter.

E1 [%] → E1[A]

123.45 % = 123.45 A

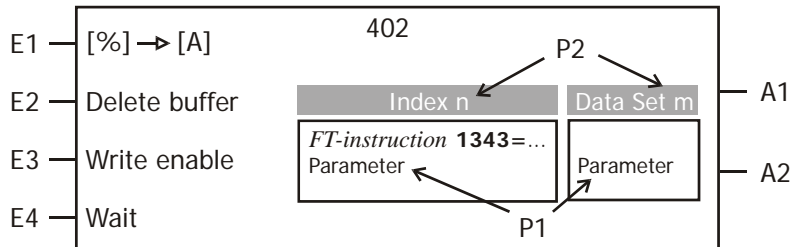

5.7.1.3 [403] Write voltage p. (eff.)

	Par#	Type	Function		Par#	Type	Function
E1	1344	%	Input value 1	A1	1350	b	E1 [%] → E1[V]
E2	1345	b	Delete buffer	A2	1351	b	inverted Output = -A1
E3	1346	b	Write enable	P1	1348	i	Parameter number
E4	1347	b	Wait until Writing complete	P2	1349	i	Data set (0 ... 9)/Index

FT-instruction 1343 = "403 - Write voltage p. (eff.)"

Description:

The effective input value is converted from percent into Volt and written as int-Parameter.

$E1 [\%] \rightarrow E1[V]$

123.45 % = 123.45 V

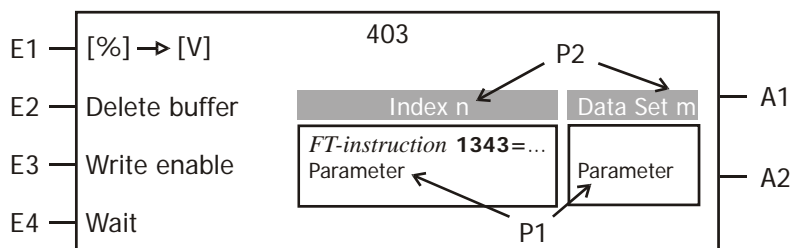

5.7.1.4 [404] Write voltage p. (peak)

	Par#	Type	Function		Par#	Type	Function
E1	1344	%	Input value 1	A1	1350	b	E1 [%] → E1[V]
E2	1345	b	Delete buffer	A2	1351	b	inverted Output = -A1
E3	1346	b	Write enable	P1	1348	i	Parameter number
E4	1347	b	Wait until Writing complete	P2	1349	i	Data set (0 ... 9)/Index

FT-instruction 1343 = "404 - Write voltage p. (peak)"

Description:

The peak input value is converted from percent into Volt and written as int-Parameter.

$E1 [\%] \rightarrow E1[V]$

123.45 % = 123.45 V

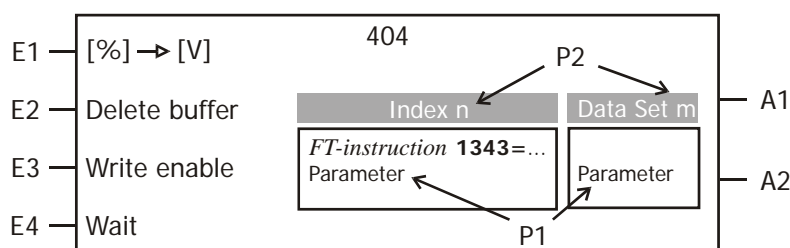

5.7.1.5 [405] Write Perc. Parameter

	Par#	Type	Function
E1	1344	%	Input value 1
E2	1345	b	Delete buffer
E3	1346	b	Write enable
E4	1347	b	Wait until Writing complete

	Par#	Type	Function
A1	1350	b	E1 [int]
A2	1351	b	inverted Output = -A1
P1	1348	i	Parameter number
P2	1349	i	Data set (0 ... 9)/Index

FT-instruction 1343 = „405 - Write Perc. Parameter“

Description:

The input value is written as an int parameter without any changes. Therefore this function can be used for any (int) parameter type.

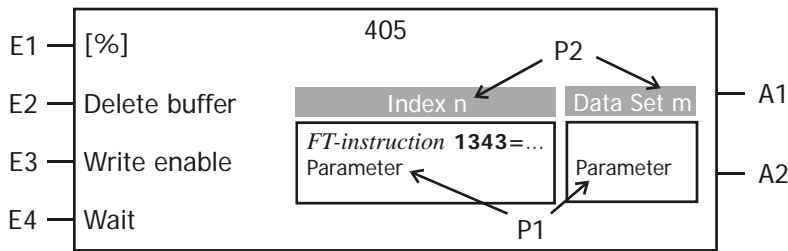

5.7.1.6 [406] Write Position Parameter

	Par#	Type	Function
E1	1344	Pos	Input value Low-word
E2	1345	Pos	Input value High-word
E3	1346	b	Delete buffer
E4	1347	b	Wait until Writing complete

	Par#	Type	Function
A1	1350	b	A1 = E2 E1
A2	1351	b	inverted Output = -A1
P1	1348	i	Parameter number
P2	1349	i	Data set (0 ... 9)/Index

FT-instruction 1343 = „406 – Write Position Parameter“

Description:

The input value is written as a long parameter without any changes. Therefore this function can be used for any (long) parameter type.

A1 = E2|E1

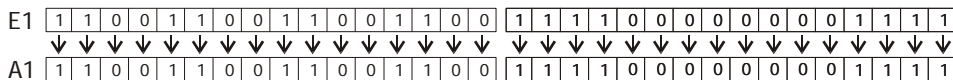

(The Bits show arbitrary values as an example.)

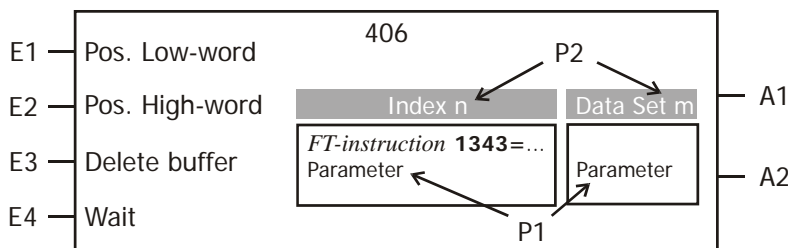

5.7.1.7 [407] Write Long Parameter

	Par#	Type	Function			Par#	Type	Function
E1	1344	%	Input value	Low-word	A1	1350	b	A1 = E2 E1
E2	1345	%		High-word	A2	1351	b	inverted Output = -A1
E3	1346	b	Delete buffer		P1	1348	i	Parameter number
E4	1347	b	Wait until Writing complete		P2	1349	i	Data set (0 ... 9)/Index

FT-instruction 1343 = "407 - Write Long Parameter"

Description:

The input value is merged from the Low-word and High-word and written as long-Parameter. Therefore this function can be used for any (long) parameter type.

A1 = E2|E1 (High-word|Low-word)

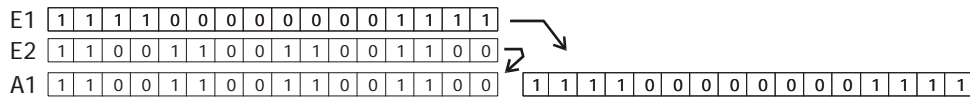

(The Bits show arbitrary values as an example.)

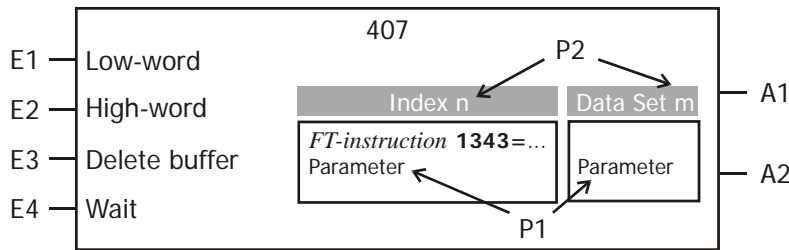

5.7.1.8 [408] Write Word Parameter

	Par#	Type	Function		Par#	Type	Function
E1	1344			A1	1350		
E2	1345			A2	1351		
E3	1346			P1	1348		
E4	1347			P2	1349		

FT-instruction 1343 = "408 - Write Word Parameter"

5.7.2 Read parameter

The read access allows reading directly all inverter parameters. This is especially helpful, if the parameter is not mapped to a source. Since the read access has to access the Non-Real-Time inverter system, this instruction may take longer than 1 ms to process. The instruction is processed as long as the parameter value is read, even if this takes longer than the standard 1 ms processing time.

If an invalid value for the data set or index is selected, the data set (or index) according to the following table is used instead.

Data set / Index	Change over capable parameters:	Not Change over capable parameters:
0	Data set 1 is used instead. Index 1 is used instead.	Data set 0
1..4 / 1..max.Index	Value of Data set 1...4 Value of Index 1...max.Index	Data set 0
Invalid value	Data set 1 (or index 1) is used instead.	Data set 0

Please note, that only the data sets from the RAM are accessed. For read access, there is no necessity to read from EEPROM, so these values are not accessible.

5.7.2.1 [421] Read frequency parameter

	Par#	Type	Function		Par#	Type	Function
E1	1344	-	-	A1	1350	%	Parameter Value [Hz]
E2	1345	-	-	A2	1351	%	Inverted Output = -A1
E3	1346	b	Read enable	P1	1348	i	Parameter number
E4	1347	-	-	P2	1349	i	Data set (0 ... 4)/Index

FT-instruction 1343 = "421 - Read frequency parameter"

Description:

This function reads in the value of the parameter set in 1348 "Parameter number" and 1349 "Data set/Index". The value is transformed into a frequency value. The input E3 enables the read signal.

E3 = 0: Read access is not processed.

E3 = 1: Parameter value is read, instruction is processed as long as it takes to read the value.

5.7.2.2 [422] Read current parameter

	Par#	Type	Function		Par#	Type	Function
E1	1344	-	-	A1	1350	%	Parameter Value [A]
E2	1345	-	-	A2	1351	%	Inverted Output = -A1
E3	1346	b	Read enable	P1	1348	i	Parameter number
E4	1347	-	-	P2	1349	i	Data set (0 ... 4)/Index

FT-instruction 1343 = "422 - Read current parameter"

Description:

This function reads in the value of the parameter set in 1348 "Parameter number" and 1349 "Data set/Index". The value is transformed into a current value. The input E3 enables the read signal.

E3 = 0: Read access is not processed.

E3 = 1: Parameter value is read, instruction is processed as long as it takes to read the value.

5.7.2.3 [423] Read voltage p. (eff.)

	Par#	Type	Function		Par#	Type	Function
E1	1344	-	-	A1	1350	%	Parameter Value [V]
E2	1345	-	-	A2	1351	%	Inverted Output = -A1
E3	1346	b	Read enable	P1	1348	i	Parameter number
E4	1347	-	-	P2	1349	i	Data set (0 ... 4)/Index

FT-instruction 1343 = "423 - Read voltage p. (eff.)"

Description:

This function reads in the value of the parameter set in 1348 "Parameter number" and 1349 "Data set/Index". The value is transformed into a voltage value. The input E3 enables the read signal.

E3 = 0: Read access is not processed.

E3 = 1: Parameter value is read, instruction is processed as long as it takes to read the value.

5.7.2.4 [424] Read voltage p. (peak)

	Par#	Type	Function		Par#	Type	Function
E1	1344	-	-	A1	1350	%	Parameter Value [V]
E2	1345	-	-	A2	1351	%	Inverted Output = -A1
E3	1346	b	Read enable	P1	1348	i	Parameter number
E4	1347	-	-	P2	1349	i	Data set (0 ... 4)/Index

FT-instruction 1343 = "424 - Read voltage p. (peak)"

Description:

This function reads in the value of the parameter set in 1348 "Parameter number" and 1349 "Data set/Index". The value is transformed into a voltage value. The input E3 enables the read signal.

E3 = 0: Read access is not processed.

E3 = 1: Parameter value is read, instruction is processed as long as it takes to read the value.

5.7.2.5 [425] Read Perc. Parameter

	Par#	Type	Function		Par#	Type	Function
E1	1344	-	-	A1	1350	%	Parameter Value [%]
E2	1345	-	-	A2	1351	%	Inverted Output = -A1
E3	1346	b	Read enable	P1	1348	i	Parameter number
E4	1347	-	-	P2	1349	i	Data set (0 ... 4)/Index

FT-instruction 1343 = "425 - Read Perc. Parameter"

Description:

This function reads in the value of the parameter set in 1348 "Parameter number" and 1349 "Data set/Index". The value is transformed into a Percentage value. The input E3 enables the read signal.

E3 = 0: Read access is not processed.

E3 = 1: Parameter value is read, instruction is processed as long as it takes to read the value.

5.7.2.6 [426] Read Position Parameter

	Par#	Type	Function		Par#	Type	Function
E1	1344	-	-	A1	1350	%	Position value
E2	1345	-	-	A2	1351	%	
E3	1346	b	Read enable	P1	1348	i	High word
E4	1347	-	-	P2	1349	i	Parameter number
							Data set (0 ... 4)/Index

FT-instruction 1343 = "426 - Read Position Parameter"

Description:

This function reads in the value of the parameter set in 1348 "Parameter number" and 1349 "Data set/Index". The value is transformed into a Position value. The input E3 enables the read signal.

E3 = 0: Read access is not processed.

E3 = 1: Parameter value is read, instruction is processed as long as it takes to read the value.

5.7.2.7 [427] Read Long Parameter

	Par#	Type	Function		Par#	Type	Function
E1	1344	-	-	A1	1350	%	Long value
E2	1345	-	-	A2	1351	%	
E3	1346	b	Read enable	P1	1348	i	High word
E4	1347	-	-	P2	1349	i	Parameter number
							Data set (0 ... 4)/Index

FT-instruction 1343 = "427 - Read Long Parameter"

Description:

This function reads in the value of the parameter set in 1348 "Parameter number" and 1349 "Data set/Index". The value is transformed into a Long value. The input E3 enables the read signal.

E3 = 0: Read access is not processed.

E3 = 1: Parameter value is read, instruction is processed as long as it takes to read the value.

5.7.2.8 [428] Read Word Parameter

	Par#	Type	Function		Par#	Type	Function
E1	1344	-	-	A1	1350	%	
E2	1345	-	-	A2	1351	%	
E3	1346	b	Read enable	P1	1348	i	Parameter number
E4	1347	-	-	P2	1349	i	Data set (0 ... 4)/Index

FT-instruction 1343 = "428 - Read Word Parameter"

5.8 Limiter

5.8.1 [440] Limiter (Const.)

	Par#	Type	Function		Par#	Type	Function
E1	1344	%	Input value 1	A1	1350	%	$A1 = E1_{P2}^{P1}$
E2	1345	-	-	A2	1351	%	inverted Output = -A1
E3	1346	-	-	P1	1348	%	upper limit
E4	1347	b	Master Reset	P2	1349	%	lower limit

FT-instruction 1343 = "440 - Limiter (Const.)"

Description:

The input value E1 is limited to the upper limit by P1 and to the lower limit by P2.

$$A1 = E1_{P2}^{P1}$$

As long as E4 (Master Reset) is TRUE, the output value A1 is set to 0.

Note:

P2 can only be entered as positive value.

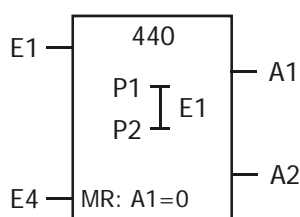
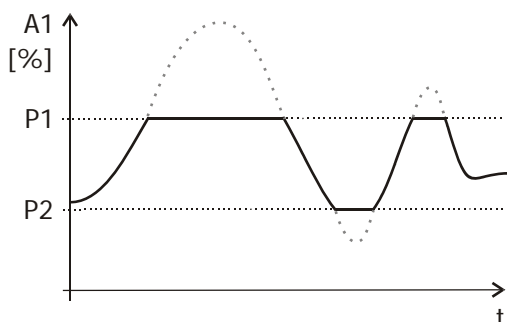

5.8.2 [441] Limiter (Variable)

	Par#	Type	Function
E1	1344	%	Input value 1
E2	1345	%	upper limit
E3	1346	%	lower limit
E4	1347	b	Master Reset

	Par#	Type	Function
A1	1350	%	$A1 = E1 \begin{matrix} E2 \uparrow \\ E3 \downarrow \end{matrix}$
A2	1351	%	inverted Output = -A1
P1	1348	-	-
P2	1349	-	-

FT-instruction **1343** = "441 - Limiter (Variable)"

Description:

The input value E1 is limited to the upper limit by E2 and to the lower limit by E3.

$$A1 = E1 \begin{matrix} E2 \uparrow \\ E3 \downarrow \end{matrix}$$

As long as E4 (Master Reset) is TRUE, the output value A1 is set to 0.

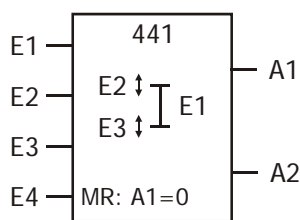
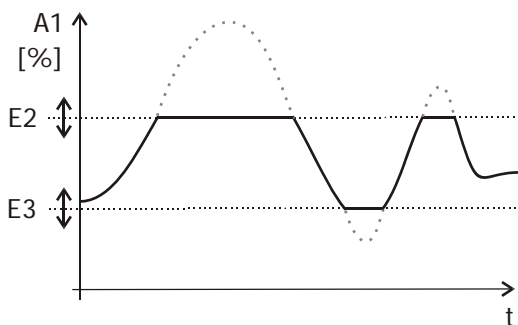
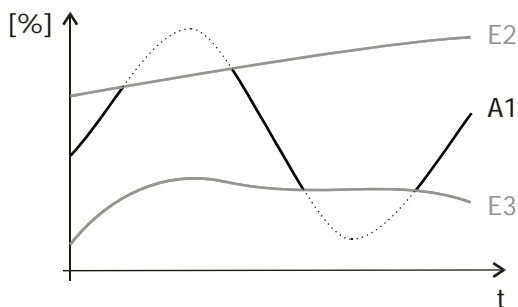

5.9 Counter

5.9.1 [450] Up/Down Counter with analogue output

	Par#	Type	Function
E1	1344	b	Clock up
E2	1345	b	Clock down
E3	1346	b	Master Set
E4	1347	b	Master Reset

	Par#	Type	Function
A1	1350	%	A1 = Clock E1 - Clock E2
A2	1351	%	inverted Output = -A1
P1	1348	i	Steps upwards for 100.00%
P2	1349	i	Steps downwards for 100.00%

FT-instruction **1343** = "450 - Up/Down Counter with analogue output"

Description:

- Each positive edge at input E1 increases the output value A1 by $100.00\%/P1$.
- Each positive edge at input E2 decreases the output value A1 by $100.00\%/P2$.
- The output values are limited to the range of 0.00% ... 100.00%.
- Input Master Set E3 sets the output A1 to 100.00 %. This input has a higher priority than edges at E1 or E2.
- Input Master Reset E4 sets the output A1 to 0.00 %. This input has a higher priority than edges at E1 or E2 and Master Set E3.

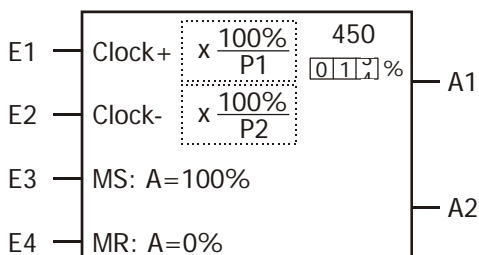
**Application examples:**

- Reference value setting with two buttons. Each time, the button is pushed, the reference value is increased or decreased with an adjustable value.
- Counting of (fault-) events. Each event increases the counter. This counter can trigger another functionality, i.e. too many faults.

Example: P1 = 6, P2 = 4

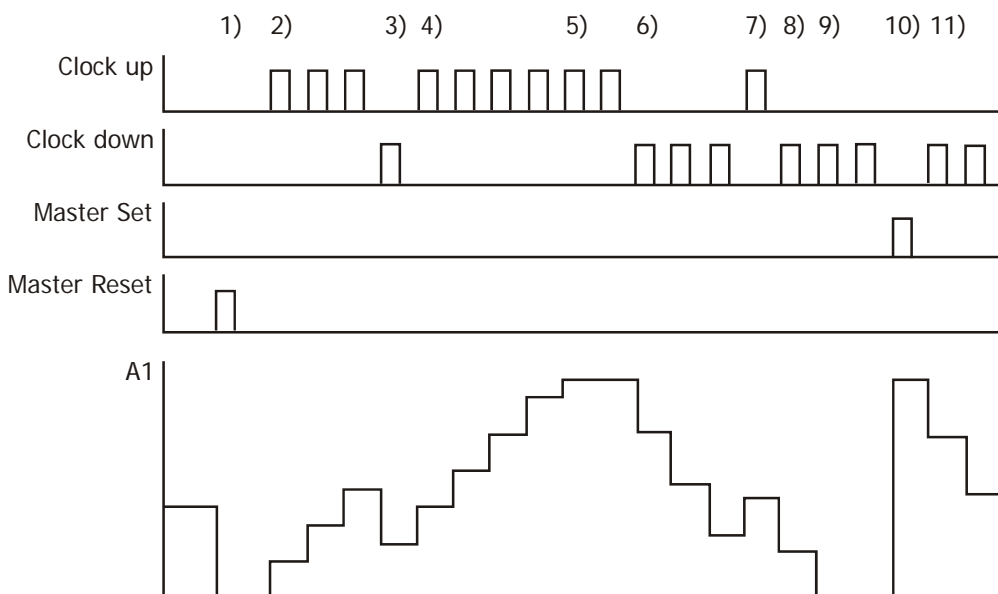

- 1) Master-Reset sets the output A1 to Zero.
- 2) Three counting pulses upwards (each $100.00\%/P1 = 100.00\%/6 = 16.67\%$)
- 3) One counting pulse downwards. ($100.00\%/P2 = 100.00\%/4 = 25\%$)
- 4) Four counting pulses upwards (each $100.00\%/P1 = 100.00\%/6 = 16.67\%$)
- 5) Two counting pulses upwards, Limitation to 100.00%
- 6) Three counting pulses downwards. (je $100.00\%/P2 = 100.00\%/4 = 25\%$)
- 7) One Counting pulse upwards ($100.00\%/P1 = 100.00\%/6 = 16.67\%$)
- 8) One Counting pulse downwards. ($100.00\%/P2 = 100.00\%/4 = 25\%$)
- 9) Two Counting pulses downwards, Limitation to Zero.
- 10) Master-Set sets the output A1 to 100.00%
- 11) Two Counting pulses downwards. (each $100.00\%/P2 = 100.00\%/4 = 25\%$)

Note:

P1 and P2 are limited internally to 100.00 %. If a larger value is entered, 100.00 % is taken instead.

5.9.2 [451] Clock with analogue output

	Par#	Type	Function		Par#	Type	Function
E1	1344	b	Enable	A1	1350	%	(clock in ms)/P2
E2	1345	b	Enable, inverted	A2	1351	%	inverted Output = -A1
E3	1346	b	Counting direction	P1	1348	%	Start value
E4	1347	b	Reset	P2	1349	i	Divisor

FT-instruction **1343** = "451 - Clock with analogue output"

Description:

- The clock is activated, if E1 = TRUE and E2 = FALSE. In all other cases, the clock is stopped.
- Input 3 determines the sense of counting.
E3 = TRUE: Clock runs upwards (cw),
E3 = FALSE: Clock runs downwards (acw).
- A positive edge at input E4 sets the clock (output A1) to the start value P1. The following negative edge of E4 starts the clock (if E1 = TRUE and E2 = FALSE).
- P2 specifies the Divisor, which is used to convert the internal value into the outputs value.
- The output value is limited to the range 0.00% ... 327.67%.

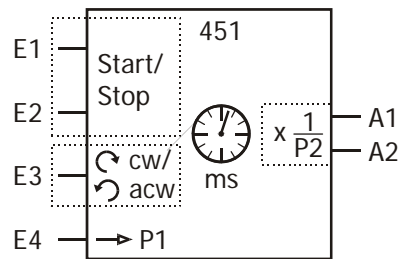

E1	E2	E3	E4	Function
1	0	1	x	Clock runs upwards
1	0	0	x	Clock runs downwards
1	0	x	0→1	Reset to Start value P1
1	0	x	1→0	Start after reset

Examples:

If E1 (Enable) = TRUE, E2 (Enable, inverted) = FALSE, E3 (Counting direction) = TRUE, E4 (Reset) = FALSE, the internal counter (long) is increased by one each millisecond. To calculate the output value, the internal value is divided by P2.

1) P2 = 1, Time: one second (1000 ms).

$$\text{Output value: } A1 = \frac{t}{P2} = \frac{1\text{ s}}{1} = \frac{1000\text{ ms}}{1 \times 100 \frac{\text{ms}}{\%}} = 10\%$$

The output reaches after one second the value 10%.

2) P2 = 1000, Time: one hour (3600 s).

$$\text{Output value: } A1 = \frac{t}{P2} = \frac{3600\text{ s}}{1000} = \frac{3\,600\,000\text{ ms}}{1000 \times 100 \frac{\text{ms}}{\%}} = 36\%$$

The output reaches after one hour the value 36%.

5.10 Positioning functions

The positioning can be controlled from the function table. The operation mode of the positioning can be transferred to the function table.

Output A2|A1 (High-word|Low-word) signalizes the actual position value. In operation mode 507 - "Check state" the output signalizes a motion block activation.

Note:

The application manual "Positioning" describes the positioning functions in configurations x40.

5.10.1 [501] Start Motion Block (Single mode)

	Par#	Type	Function		Par#	Type	Function
E1	1344	Pos	Target position offset	A1	1350	Pos	Actual position
E2	1345	%	-	A2	1351	Pos	
E3	1346	b	Enable	P1	1348	i	Number of motion block (Index of motion blocks table)
E4	1347	b	Wait until positioning is terminated	P2	1349	-	-

FT-instruction 1343 = "501 - Start Motion Block (Single mode)"

Description:

The motion block (selected via P1) starts. Repetitions and next motion blocks are not executed. Target position offset at input E1 is added to the target position of the motion block.

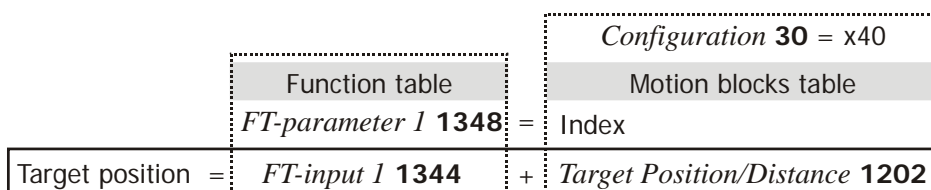

Input E1 can be linked with position values (long).

The function is carried out only if input E3 (Enable) is set.

If input E4 (Wait) is set, following instructions are processed only when the target position is reached. The procedure cannot be interrupted by other instructions or by resetting E3.

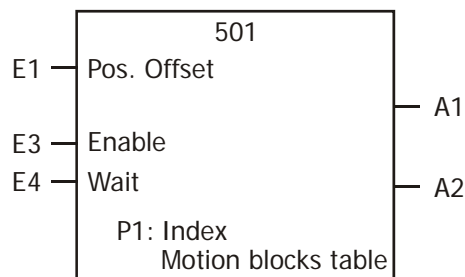

E3	E4	Function
1	0	Start motion block P1. Interruption via another instruction is possible. Target position can be changed even if the target position is not reached. The motion block restarts.
1	1	Start motion block P1 and wait until positioning is terminated.
0	0	Target position is not changed.
0	1	Target position can be changed if no positioning is active.

5.10.2 [502] Start Motion Block (Automatic mode)

	Par#	Type	Function		Par#	Type	Function
E1	1344	Pos	Target position offset	A1	1350	Pos	Actual position Low-word
E2	1345	%	-	A2	1351	Pos	
E3	1346	b	Enable	P1	1348	i	Number of motion block (Index of motion blocks table)
E4	1347	b	Wait until positioning is terminated	P2	1349	-	-

FT-instruction 1343 = "502 - Start Motion Block (Automatic mode)"

Description:

The motion block (selected via P1) starts. Repetitions and next motion blocks are executed.

Target position offset at input E1 is added to the target position of the motion block.

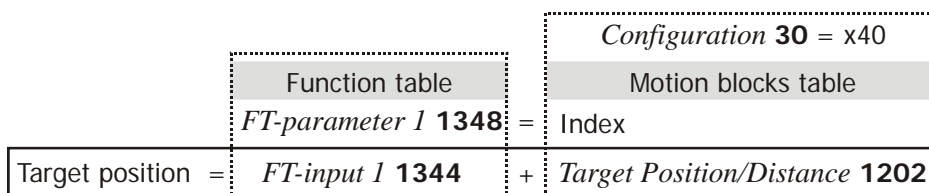

Input E1 can be linked with position values (long).

The function is carried out only if input E3 (Enable) is set.

If input E4 (Wait) is set, following instructions will be processed only when the target position has been reached. The procedure cannot be interrupted by other instructions or by resetting E3.

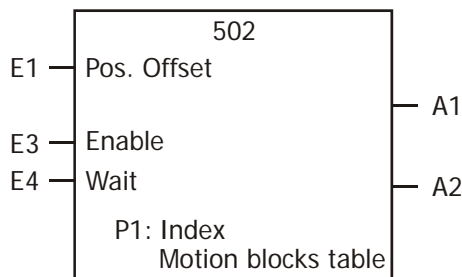

E3	E4	Function
1	0	Start motion block P1 including next motion blocks. Interruption via another instruction is possible. Target position can be changed even if the target position is not reached. The motion block restarts.
1	1	Start motion block P1 including next motion blocks and wait until positioning is terminated.
0	0	Target position is not changed.
0	1	Target position can be changed if no positioning is active.

5.10.3 [503] Motion Block: Interrupt

	Par#	Type	Function		Par#	Type	Function
E1	1344	-	-	A1	1350	Pos	Actual position Low-word
E2	1345	-	-	A2	1351	Pos	
E3	1346	b	Enable	P1	1348	-	-
E4	1347	b	Wait until drive has stopped	P2	1349	-	-

FT-instruction 1343 = "503 - Motion Block: Interrupt"

Description:

The current motion block is interrupted if input E3 (Enable) is set. The drive stops. If E3 is reset the interrupted motion block continues and repetitions and next motion blocks are executed.

If input E4 (Wait) is set, following instructions will be processed only when the drive has been stopped. The procedure cannot be interrupted by other instructions or by resetting E3.

The instruction is processed only if input E3 (Enable) is set.

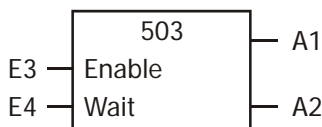

E3	E4	Function
1	0	Stop drive
1	1	Wait

5.10.4 [504] Motion Block: Continue

	Par#	Type	Function	
E1	1344	-	-	
E2	1345	-	-	
E3	1346	b	Enable	
E4	1347	b	Wait until motion block is terminated	

	Par#	Type	Function	
A1	1350	Pos	Actual position	Low-word
A2	1351	Pos	Actual position	High-word
P1	1348	-	-	
P2	1349	-	-	

FT-instruction 1343 = "504 - Motion Block: Continue"

Description:

An interrupted motion block will be continued.

The instruction is processed only if input E3 (Enable) is set.

If input E4 (Wait) is set, following instructions will be processed only when the motion block (with repetitions) or an automatic sequence has been terminated. The procedure cannot be interrupted by other instructions or by resetting E3.

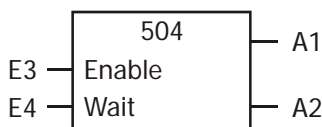

E3	E4	Function
1	0	Continue motion block
1	1	Wait

5.10.5 [505] Motion Block: Resume

	Par#	Type	Function	
E1	1344	-	-	
E2	1345	-	-	
E3	1346	b	Enable	
E4	1347	b	Wait until motion block is terminated	

	Par#	Type	Function	
A1	1350	Pos	Actual position	Low-word
A2	1351	Pos	Actual position	High-word
P1	1348	-	-	
P2	1349	-	-	

FT-instruction 1343 = "505 - Motion Block: Resume"

Description:

A motion block that has been interrupted by fault cutoff or mains power failure will be continued.

The instruction is processed only if input E3 (Enable) is set.

If input E4 (Wait) is set, following instructions will be processed only when the motion block (with repetitions) or an automatic sequence has been terminated. The procedure cannot be interrupted by other instructions or by resetting E3.

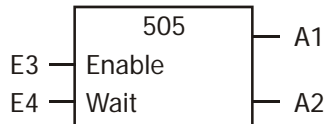

E3	E4	Function
1	0	Resume motion block
1	1	Wait

5.10.6 [506] Start Homing

	Par#	Type	Function
E1	1344	-	-
E2	1345	-	-
E3	1346	b	Enable
E4	1347	b	Wait until home position is reached

	Par#	Type	Function
A1	1350	Pos	Actual position
A2	1351	Pos	
P1	1348	i	Homing mode
P2	1349	-	-

FT-instruction 1343 = "506 - Start Homing"

Description:

The homing mode (set in P1) starts. An active motion block is interrupted.

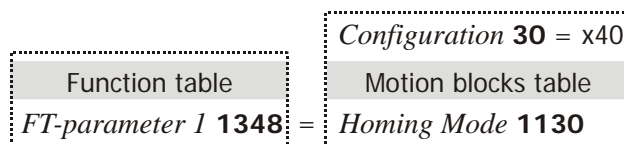

The instruction is processed only if input E3 (Enable) is set.

If input E4 (Wait) is set, following instructions will be processed only when the home position is reached. The procedure cannot be interrupted by other instructions or by resetting E3.

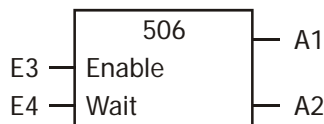

E3	E4	Function
1	0	Start homing mode P1
1	1	Wait

5.10.7 [507] Check state

	Par#	Type	Function
E1	1344	-	-
E2	1345	-	-
E3	1346	-	-
E4	1347	b	Wait until motion block is terminated

	Par#	Type	Function
A1	1350	b	TRUE if motion block is active
A2	1351	b	FALSE if motion block is active
P1	1348	-	-
P2	1349	-	-

FT-instruction 1343 = "507 - Check state"

Description:

The function sets output A1 to TRUE if a motion block is active.

If input E4 (Wait) is set, following instructions will be processed only when the motion block (with repetitions) or an automatic sequence has been terminated. The procedure cannot be interrupted by other instructions or by resetting E3.

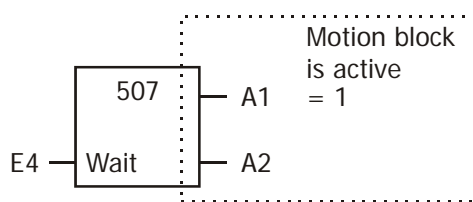

Motion block is active	E4	A1 =
yes	0	1
no	x	0
yes	1	Wait

5.11 Bit-Functions for analog input values

Each single Bit of the input E1 is combined with the corresponding bits of input E2 and the parameter P1 (if applicable).

The result is stored in the corresponding Bit of the output value.

In example the Bit 3 of the output value is dependent of

- Bit 3 of Input value E1 and
- Bit 3 of Input value E2 and
- Bit 3 of Parameter P1.

The parameter P2 specifies, if input value E1 is linked with input value E2 or parameter P1:

- P2 = 1: Combination of Input value E1 with Input value I2
- P2 = 2: Combination of Input value E1 with Parameter P1
- P2 = 3: Combination of Input value E1 with Input value I2 und Parameter P1

Master Set sets all Bits of the output value (Output = 0xFFFF).

Master Reset resets all Bits of the output value (Output = 0x0000).

Output A2 is the inverted output A1 with the bits inverted bit by bit.

Example: A1 = 0xFF00 → A2 = 0x00FF.

5.11.1 [200] Bit by Bit NOT

	Par#	Type	Function		Par#	Type	Function
E1	1344	%	Input value 1	A1	1350	%	E1 (E1 bitwise inverted)
E2	1345	-	-	A2	1351	%	inverted Output (=E1)
E3	1346	b	Master Set	P1	1348	-	-
E4	1347	b	Master Reset	P2	1349	-	-

FT-instruction 1343 = "200 - Bit by Bit NOT"

Description:

Output A1 is the (bit by bit) inverted input value E1 ($A1 = \neg E1$).

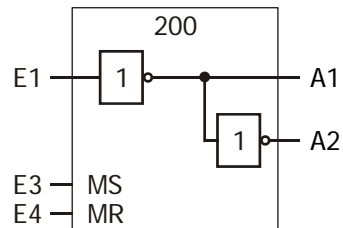

Example: $E1 = 0xF00F \rightarrow A1 = 0x0FF0, A2 = 0xF00F$

Master Set sets all Bits of the output value (Output = $0xFFFF$).

Master Reset resets all Bits of the output value (Output = $0x0000$).

Note:

A2 is the inverted value of A1, resulting in $A2 = \neg A1$.

5.11.2 [201] Bit by Bit AND/NAND

	Par#	Type	Function		Par#	Type	Function
E1	1344	%	Input value 1	A1	1350	%	$A1 = \text{AND}(E1, E2)$; if $P2=1$, $A1 = \text{AND}(E1, P1)$, if $P2=2$, $A1 = \text{AND}(E1, E2, P1)$, if $P2=3$
E2	1345	%	Input value 2	A2	1351	%	inverted Output (NAND)
E3	1346	b	Master Set	P1	1348	%	Mask
E4	1347	b	Master Reset	P2	1349	i	Operation mode (1, 2 or 3)

FT-instruction 1343 = "201 - Bit by Bit AND/NAND"

Description:

The input value E1 is combined with an AND element. Via P2 the other element(s) can be selected:

- $P2 = 1$: E1 and E2 are AND combined.
- $P2 = 2$: E1 and P1 are AND- combined.
- $P2 = 3$: E1, E2 and P1 are AND- combined.

Master Set sets all Bits of the output value (Output = $0xFFFF$).

Master Reset resets all Bits of the output value (Output = $0x0000$).

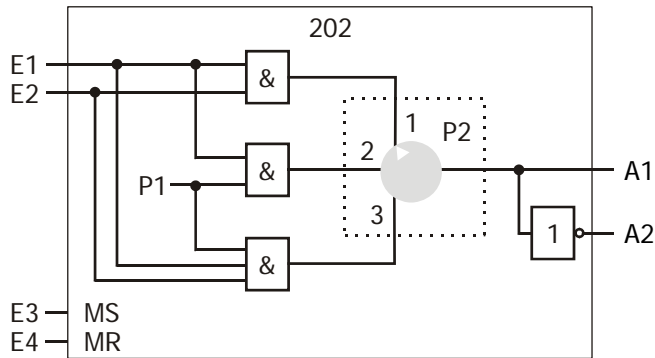

Example:

	P2	E1	E2	P1	A1	A2
1)	AND (E1 E2)	0xF00F	0x0F0F	-	0x000F	0xFFFF
2)	AND (E1 P1)	0xF00F	-	0x00FF	0x000F	0xFFFF
3)	AND (E1 E2 P1)	0xF00F	0x0F0F	0x00FF	0x000F	0xFFFF

Explanation Example 1):

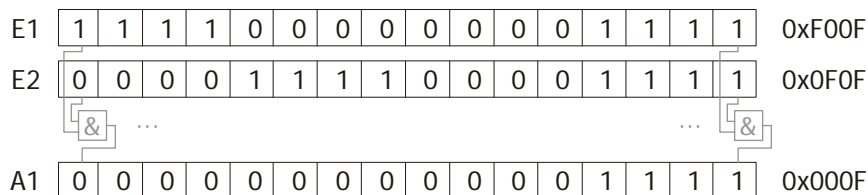

5.11.3 [202] Bit by Bit OR/NOR

	Par#	Type	Function		Par#	Type	Function
E1	1344	%	Input value 1	A1	1350	%	A1=OR (E1 E2); if P2=1, A1=OR (E1 P1), if P2=2, A1=OR (E1 E2 P1), if P2=3
E2	1345	%	Input value 2	A2	1351	%	inverted Output (NOR)
E3	1346	b	Master Set	P1	1348	%	Mask
E4	1347	b	Master Reset	P2	1349	i	Operation mode (1, 2 or 3)

FT-instruction **1343** = „202 - Bit by Bit OR/NOR“

Description:

The input value E1 is combined with an OR element. Via P2 the other element(s) can be selected:

- P2 = 1: E1 OR E2 are OR-combined.
- P2 = 2: E1 OR P1 are OR-combined.
- P2 = 3: E1, E2 OR P1 are OR-combined.

Master Set sets all Bits of the output value (Output = 0xFFFF).

Master Reset resets all Bits of the output value (Output = 0x0000).

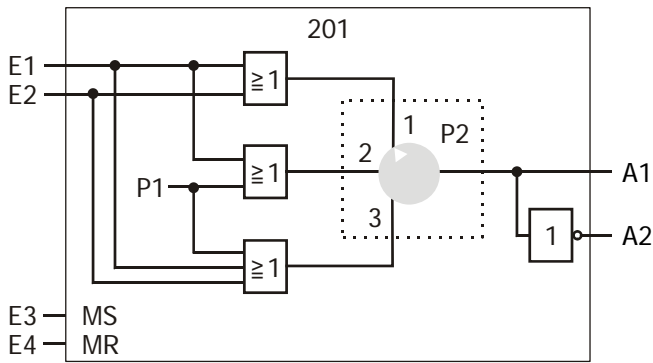

Example:

P2	E1	E2	P1	A1	A2
1) OR (E1 E2)	0xF00F	0x0F0F	-	0xFF0F	0x00F0
2) OR (E1 P1)	0xF00F	-	0x00FF	0xF0FF	0x0F00
3) OR (E1 E2 P1)	0xF00F	0x0F0F	0x00FF	0xFFFF	0x0000

Explanation Example 1):

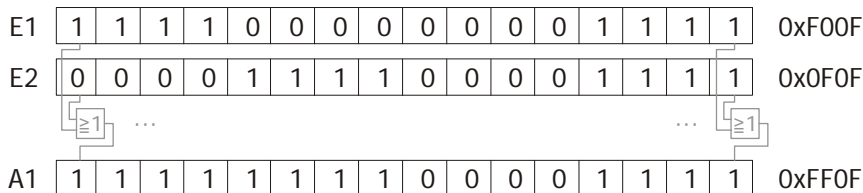

5.11.4 [203] Bit by Bit XOR/XNOR

Par#	Type	Function	Par#	Type	Function		
E1	1344	%	Input value 1	A1	1350	%	A1=XOR (E1 E2); if P2=1, A1=XOR (E1 P1), if P2=2, A1=XOR {XOR (E1 E2) P1}, if P2=3
E2	1345	%	Input value 2	A2	1351	%	inverted Output (XNOR)
E3	1346	b	Master Set	P1	1348	%	Mask
E4	1347	b	Master Reset	P2	1349	i	Operation mode (1, 2 or 3)

FT-instruction 1343 = "203 - Bit by Bit XOR/XNOR"

Description:

The input value E1 is combined with an XOR element. Via P2 the other element(s) can be selected:

- P2 = 1: E1 XOR E2 are XOR combined.
- P2 = 2: E1 XOR P1 are XOR combined.
- P2 = 3: E1, E2 XOR P1 are XOR combined.

Master Set sets all Bits of the output value (Output = 0xFFFF).

Master Reset resets all Bits of the output value (Output = 0x0000).

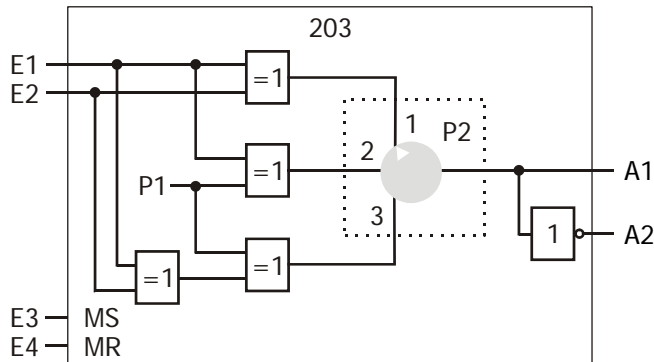

Example:

	P2	E1	E2	P1	A1	A2
1)	XOR (E1 E2)	0xF00F	0x0F0F	-	0xFF00	0x00FF
2)	XOR (E1 P1)	0xF00F	-	0x00FF	0xF0F0	0x0F0F
3)	XOR {XOR (E1 E2) P1}	0xF00F	0x0F0F	0x00FF	0xFFFF	0x0000

Explanation Example 1):

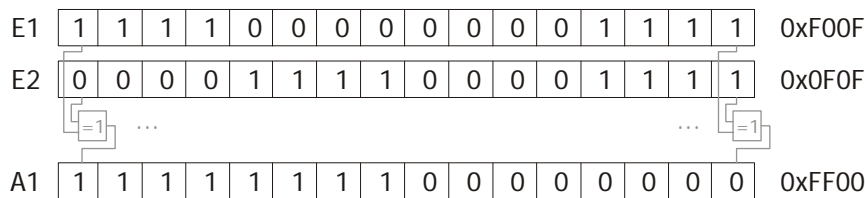

5.11.5 [210] Bit Shift right

	Par#	Type	Function
E1	1344	%	Input value 1
E2	1345	-	-
E3	1346	b	Master Set
E4	1347	b	Master Reset

	Par#	Type	Function
A1	1350	%	E1 shifted right bit by bit P2 times
A2	1351	%	inverted Output
P1	1348	-	-
P2	1349	i	Number of shifts

FT-instruction 1343 = „210 - Bit Shift right“

Description:

The input value E1 is shifted right with the number of shifts P2. On the left, Zeros are added.

Master Set sets all Bits of the output value (Output = 0xFFFF).

Master Reset resets all Bits of the output value (Output = 0x0000).

Example	P2	E1	A1	A2
1)	1: One shift	0xF00F	0x7807	0x87F8
2)	4: Four shifts	0x00FF	0x000F	0xFFFF
3)	8: Eight shifts	0xFF00	0x00FF	0xFF00

Explanation Example 1):

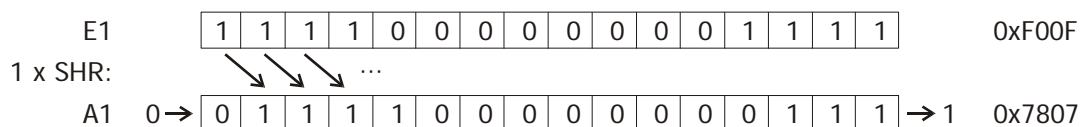

5.11.6 [211] Bit arithm. Shift Right

	Par#	Type	Function		Par#	Type	Function
E1	1344	%	Input value 1	A1	1350	%	E1 shifted right bit by bit P2 times, sign remains
E2	1345	-	-	A2	1351	%	inverted Output
E3	1346	b	Master Set	P1	1348	-	-
E4	1347	b	Master Reset	P2	1349	i	Number of shifts

FT-instruction 1343 = „211 - Bit arithm. Shift Right“

Description:

The input value E1 is shifted right with the number of shifts P2. The highest Bit (sign) remains.

Master Set sets all Bits of the output value (Output = 0xFFFF).

Master Reset resets all Bits of the output value (Output = 0x0000).

Example	P2	E1	A1	A2
1)	1: One shift	0xF00F	0xF807	0x07F8
2)	4: Four shifts	0x00FF	0x000F	0xFFFF
3)	8: Eight shifts	0xFF00	0xFFFF	0x0000

Explanation Example 1):

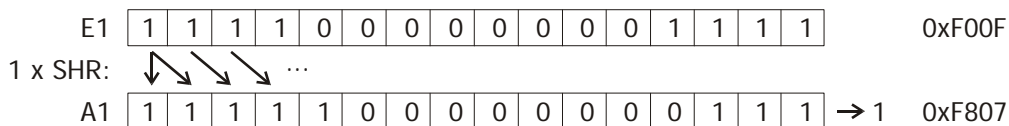
5.11.7 [212] Bit Shift left

	Par#	Type	Function		Par#	Type	Function
E1	1344	%	Input value 1	A1	1350	%	E1 shifted left bit by bit P2 times
E2	1345	-	-	A2	1351	%	inverted Output
E3	1346	b	Master Set	P1	1348	-	-
E4	1347	b	Master Reset	P2	1349	i	Number of shifts

FT-instruction 1343 = “212 - Bit Shift left”

Description:

The input value E1 is shifted left with the number of shifts P2. On the right, Zeros are added.

Master Set sets all Bits of the output value (Output = 0xFFFF).

Master Reset resets all Bits of the output value (Output = 0x0000).

Example	P2	E1	A1	A2
1)	1: One shift	0xF00F	0xE01E	0x1FE1
2)	4: Four shifts	0x00FF	0x0FF0	0xF00F
3)	8: Eight shifts	0xFF00	0x0000	0xFFFF

Explanation Example 1):

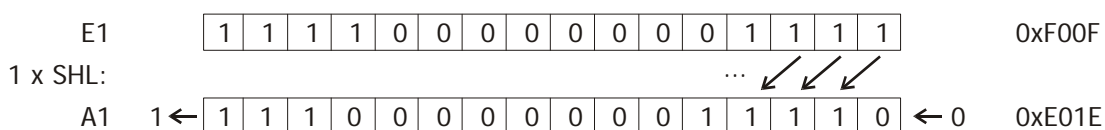

5.11.8 [213] Bit Roll right

	Par#	Type	Function		Par#	Type	Function
E1	1344	%	Input value 1	A1	1350	%	E1 shifted right bit by bit P2 times with re-inserted bits
E2	1345	-	-	A2	1351	%	inverted Output
E3	1346	b	Master Set	P1	1348	-	-
E4	1347	b	Master Reset	P2	1349	i	Number of shifts

FT-instruction 1343 = "213 - Bit Roll right"

Description:

The input value E1 is shifted right with the number of shifts P2. On the left the bits are inserted, that are pushed outside on the right side.

Master Set sets all Bits of the output value (Output = 0xFFFF).

Master Reset resets all Bits of the output value (Output = 0x0000).

Note:

A rolling of 8 Bits swaps the High-Byte and Low-Byte.

A rolling of 15 Bits to the right is equal to a rolling of one Bit to the left.

A rolling of 16 Bits doesn't results in the same output like without any rolling.

Example	P2	E1	A1	A2
1)	1: One shift	0xF00F	0xF807	0x07F8
2)	4: Four shifts	0x00FF	0xF00F	0x0FF0
3)	8: Eight shifts	0xFF00	0x00FF	0xFF00

Explanation Example 1):

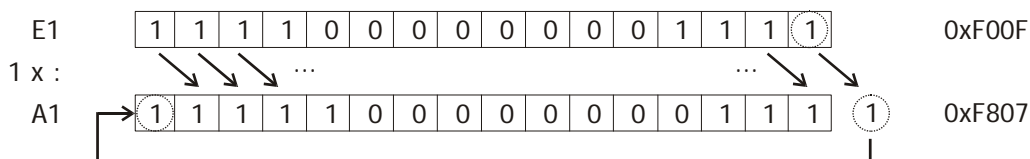

5.11.9 [220] Output 1 Bit

	Par#	Type	Function		Par#	Type	Function
E1	1344	%	Input value 1	A1	1350	b	One Bit of E1, selected via P1
E2	1345	-	-	A2	1351	b	inverted Output
E3	1346	b	Master Set	P1	1348	i	Number of Bits (0 ... 15)
E4	1347	b	Master Reset	P2	1349	-	-

FT-instruction 1343 = "220 - Output 1 Bit"

Description:

A selected Bit of input value E1 is put to the output A1. The bit is selected via P1.

P1=0: The lowest Bit (LSB) is selected.

P1=15: The highest Bit (MSB) is selected.

Master Set sets all Bits of the output value (Output = 0xFFFF).

Master Reset resets all Bits of the output value (Output = 0x0000).

Example	P1	E1	A1	A2
1)	1: Bit 1	0xF00F	1	0
2)	4: Bit 4	0x00FF	1	0
3)	4: Bit 4	0xFF00	0	1

Explanation Example 2):

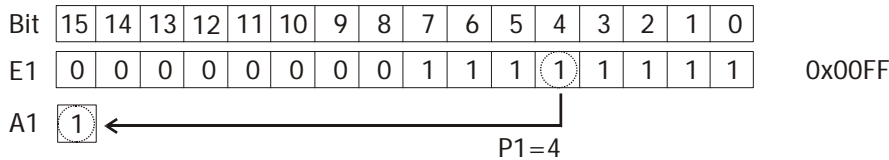

5.11.10 [221] Merge 4 Bits to 1 Word

	Par#	Type	Function		Par#	Type	Function
E1	1344	b	Input value 1	A1	1350	%	E1, E1, E3, E4 merged to one word
E2	1345	b	Input value 2	A2	1351	%	inverted Output
E3	1346	b	Input value 3	P1	1348	i	Number of first Bit (0 ... 15)
E4	1347	b	Input value 4	P2	1349	-	-

FT-instruction 1343 = "221 - Merge 4 Bits to 1 Word"

Description:

The state of the input E1 is copied into the output value A1 beginning with the bit specified via P1, the state of the input E2 is copied into the next bit and so on. All other Bits of the output value are Zero.

If P1 > 12, one or more Bits get lost.

Master Set sets all Bits of the output value (Output = 0xFFFF).

Master Reset resets all Bits of the output value (Output = 0x0000).

Example	P1	Copy	E4	E3	E2	E1	A1	A2
1)	0	E1 to Bit 0 of A1, E2 to Bit 1 of A1, E3 to Bit 2 of A1, E4 to Bit 3 of A1	1	0	1	0	0x000A	0xFFFF5
2)	5	E1 to Bit 5 of A1, E2 to Bit 6 of A1, E3 to Bit 7 of A1, E4 to Bit 8 of A1	1	0	1	0	0x0140	0xFEBF
3)	14 (P1>12)	E1 to Bit 14 of A1, E2 to Bit 15 of A1, E3 not copied, E4 not copied	1	0	1	0	0x4000	0xBFFF

Explanation Example 2):

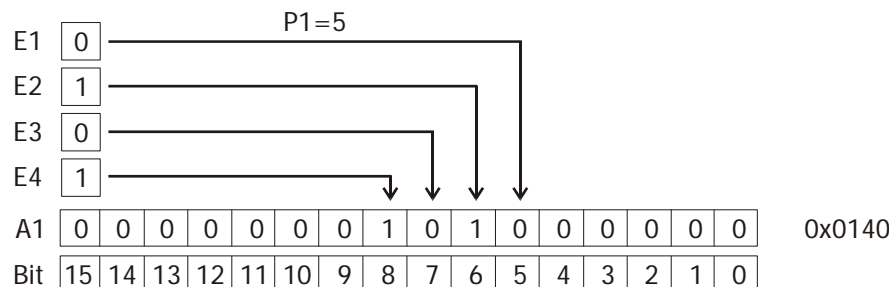

5.11.11 [222] Add 2 Bits to 1 Word

	Par#	Type	Function		Par#	Type	Function
E1	1344	%	Input word 1	A1	1350	%	A1=E1, Bit(P1)=E2, Bit(P2)=E3
E2	1345	b	Input Bit 1	A2	1351	%	inverted Output
E3	1346	b	Input Bit 2	P1	1348	i	Number of first Bit (0 ... 15)
E4	1347	b	Master Reset	P2	1349	i	Number of second Bit (0 ... 15)

FT-instruction **1343** = "222 - Add 2 Bits to 1 Word"

Description:

The bits defined in E2 and E3 are copied into the word E1. The place of E2 is defined by P1, the place of E3 is defined by P2.

- The input value E1 is copied into the output A1.
- The state of input value E2 is copied into A1 to the place specified by P1.
- The state of input value E3 is copied into A1 to the place specified by P2.

If a Bit number outside the range 0 ... 15 is specified, the Bit is not written into the word.

Example	P1	P2	Copy	E1	E2	E3	A1	A2
1)	12	11	E1 to A1, E2 to Bit 12 of A1, E3 to Bit 11 of A1	0xF00F	0	1	0xE10F	0x1EF0
2)	4	5	E1 to A1, E2 to Bit 4 of A1, E3 to Bit 5 of A1	0xF00F	1	1	0xF03F	0x0FC0
3)	0	1	E1 to A1, E2 to Bit 0 of A1, E3 to Bit 1 of A1	0xF00F	0	0	0xF00C	0x0FF3

Master Set sets all Bits of the output value (Output = 0xFFFF).

Master Reset resets all Bits of the output value (Output = 0x0000).

Explanation Example 1):

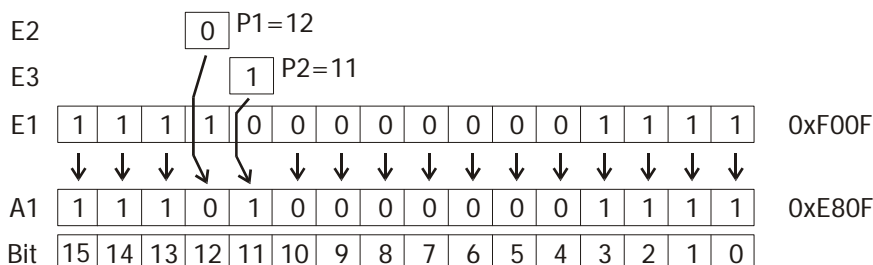

6 Examples

6.1 Example 1: Link two digital inputs

The digital inputs S2IND and S4IND should switch the digital output S1OUT. The output should have signal state TRUE if both signals apply, otherwise state FALSE.

Settings in index 1 of function table:

FT-instruction 1343 = "1 - AND",

FT-input 1 1344 = "2002 - FT-Input Buffer 2",

FT-input 2 1345 = "2004 - FT-Input Buffer 4",

FT-input 3 1346 = "6 - TRUE",

FT-input 4 1347 = "6 - TRUE",

FT-target output 1 1350 = "2401 - FT-Output Buffer 1".

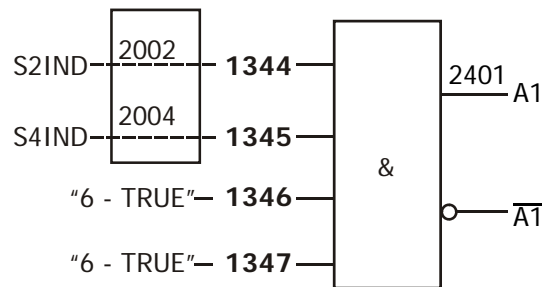

Setting in parameter group "Digital Outputs":

Op. Mode Digital Output 1 530 = "80 - FT-Output Buffer 1".

6.2 Example 2: Link of several FT-instructions

Note:

FT-instructions are processed column by column according to the function table index. For design of application specific logical links, especially time critical applications:

- Observe correct sequence of FT-instructions.
- Observe processing time of 1 ms per FT-instruction.

Example for parameterization of FT-instructions in function table:

Step 1: Conceptual formulation

The drive may start only if both start signals apply (start 1 and start 2) and no fault occurs.

The drive should shut down if at least one of the start signals does not apply.

The drive should shut down if one of the faults occurs (fault 1, fault 2 or fault 3).

Input ACK enables the acknowledgement of faults.

Digital output 1 should signalize error occurrence.

Step 2: Logic diagram

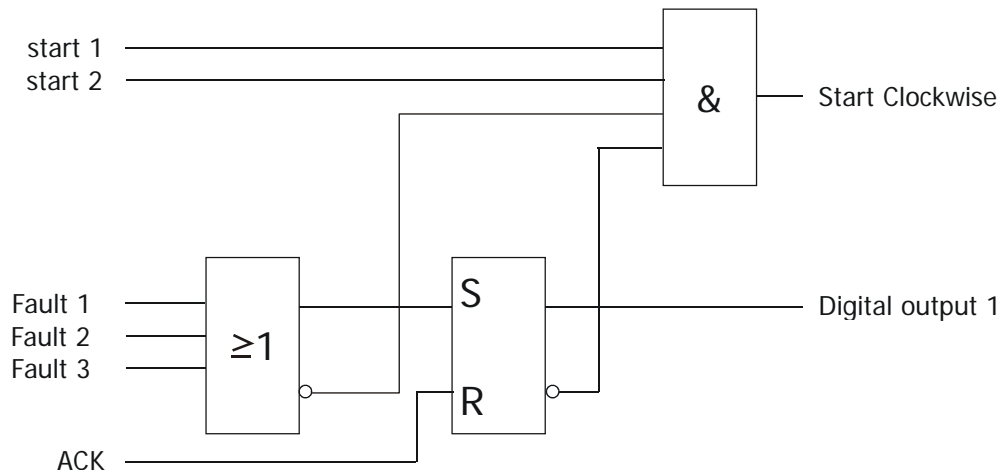

Step 3: Links and function table (VTable) input

- Link FT-instruction outputs with FT-instruction inputs in function table VTable
- Make FT-instruction outputs globally available via signal sources "2401 - FT-Output Buffer 1" to "2416 - FT-Output Buffer 16" and link with further functions (not FT-instructions).
- Signalize FT-instruction output at digital output of the device.

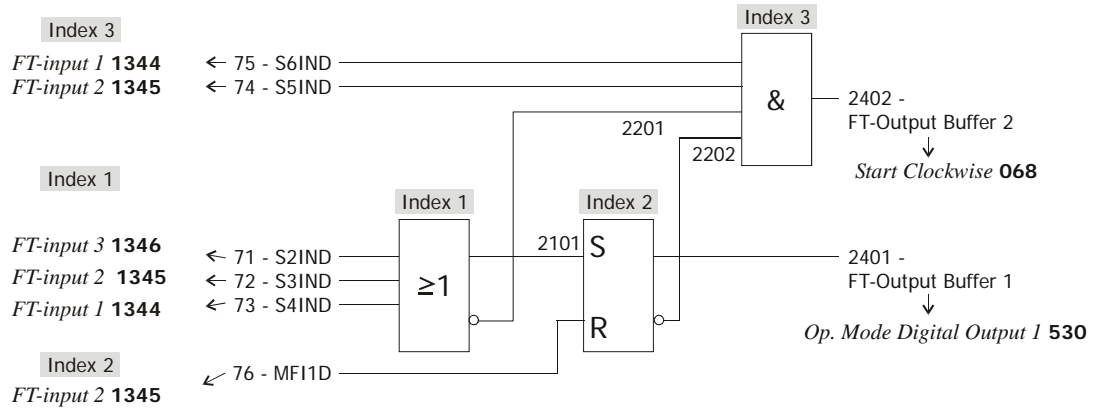

VTable

Function table input buffer	Index 2	Index 3	Index 4	Index 5	Index 6	Index 9
FT-input buffer 1362	71 - S2IND	72 - S3IND	73 - S4IND	74 - S5IND	75 - S6IND	76 - MF11D

Function table	Index 1	Index 2	Index 3
FT-instruction 1343	2 - OR	10 - RS-Flip-Flop	1 - AND
FT-input 1 1344	2004	2101	2006
FT-input 2 1345	2003	2009	2005
FT-input 3 1346	2002		2201
FT-input 4 1347			2202
FT-output 1 1350		2402	2401
FT-output 2 1351			

VPlus

Start Clockwise 068 = 2402 - FT-Output Buffer 2

Op. Mode Digital Output 1 530 = 80 - FT-Output Buffer 1

Function table	Index 1	Index 2	Index 3	Index 4
FT-instruction 1343	2 - OR	10 - RS FlipFlop Superior	1 - AND	0 - OFF (last table item)
FT-input 1 1344	2004 FT-Input Buffer 4	2101 - Outp. 1 Instruction 1	2006 - FT-Input Buffer 6	7 - FALSE
FT-input 2 1345	2003 - FT-Input Buffer 3	2009 - FT-Input Buffer 9	2005 - FT-Input Buffer 5	7 - FALSE
FT-input 3 1346	2002 - FT-Input Buffer 2	7 - FALSE	2201 - Outp. 2 Instruction 1 ¹⁾	7 - FALSE
FT-input 4 1347	7 - FALSE	7 - FALSE	2202 - Outp. 2 Instruction 2 ²⁾	7 - FALSE
FT-target output 1 1350	0 - Output not globally useable	2402 - FT-Outp. Buffer 2	2401 - FT-Outp. Buffer 1	0 - Output not globally useable
FT-target output 2 1351	0 - Output not globally useable	0 - Output not globally useable	0 - Output not globally useable	0 - Output not globally useable

¹⁾ Inverted output of instruction 1 (of OR-operation in this example)

²⁾ Inverted output of instruction 2 (of RS FlipFlop in this example)

The outputs of the instructions are available as sources and can be linked with inputs of other instructions or signaled at digital outputs of the device.

Example:

- Link of AND-instruction output with Start clockwise function, parameter *Start Clockwise* **068** = "2402 - FT-Output Buffer 2".
- Link of RS FlipFlop output with digital output S1OUT of the device, parameter *Op. Mode Digital Output 1* **530** = "80 - FT-Output Buffer 1".

6.3 Example 3: Parameterization of logic diagram

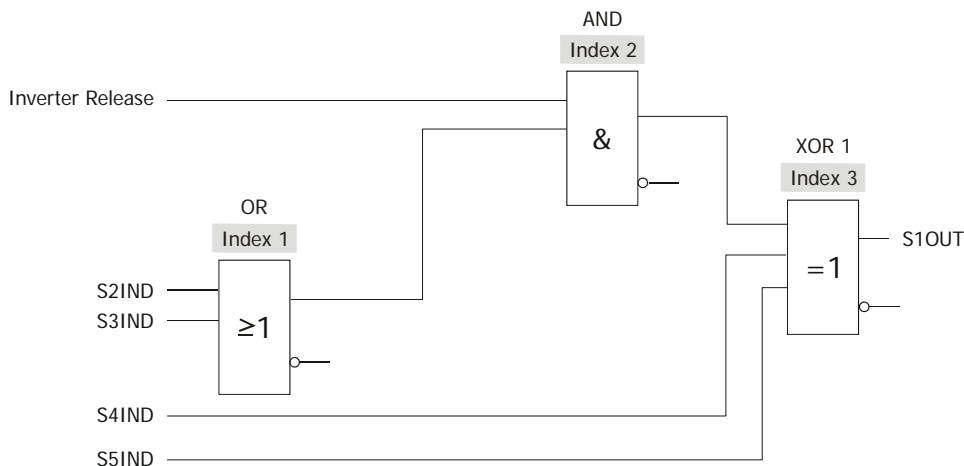

VTable

Function Table: Input Buffer	Index 1	Index 2	Index 3	Index 4	Index 5
<i>FT-input buffer</i> 1362	70 - Inverter Release	71 - S2IND	72 - S3IND	73 - S4IND	74 - S5IND

Function Table	Index 1	Index 2	Index 3
<i>FT-instruction</i> 1343	2 - OR	1 - AND	3 - XOR 1
<i>FT-input 1</i> 1344	2002	2001	2102
<i>FT-input 2</i> 1345	2003	2101	2004
<i>FT-input 3</i> 1346			2005
<i>FT-input 4</i> 1347			
<i>FT-output 1</i> 1350			2401
<i>FT-output 1</i> 1351			

VPlus

<i>Op. Mode Digital Output 1</i> 530 = 80 - FT-Output Buffer 1

7 Actual values and output signals

7.1 Actual values of digital functions

Actual values of input- and output buffer

- Actual values of global outputs “2401 to 2416 - “FT-Output Buffer” are displayed via parameter *FT-actual values output buffer* **1357**.
- Actual values of global inputs 2001 to 2016 - “FT-Input Buffer” are displayed via parameter *FT-actual values input buffer* **1358**.

Example

z. B. Display:

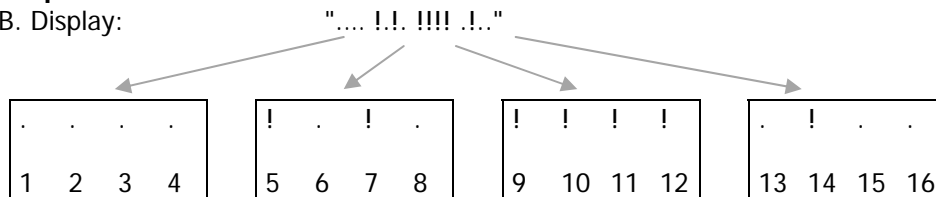

"." = FALSE

"!" = TRUE

Logic 1 in the example is:

- 2405 - FT-Output Buffer 5
- 2407 - FT-Output Buffer 7
- 2409 - FT-Output Buffer 9
- 2410 - FT-Output Buffer 10
- 2411 - FT-Output Buffer 11
- 2412 - FT-Output Buffer 12
- 2414 - FT-Output Buffer 14

Actual values of digital functions

Actual values of an instruction are displayed via *FT-actual values function* **1356**. From the left to the right following data is displayed:

- State of function table (e.g. started, stopped)
- Index of the selected instruction via *FT-read index (FT-input buffer)* **1361**
- FT-inputs of the selected instruction
- FT-outputs of the selected instruction

- Index number of the last processed instruction
- FT-inputs of the last processed instruction
- FT-outputs of the last processed instruction

The states of the function table are:
 R: Running – Function table is started
 S: Stopped – Function table is stopped
 U: Updating – Input buffer and output buffer are updated
 E: Empty – Function table is empty
 I: Initialization

Example: Display in parameter *FT-actual values function 1356:*

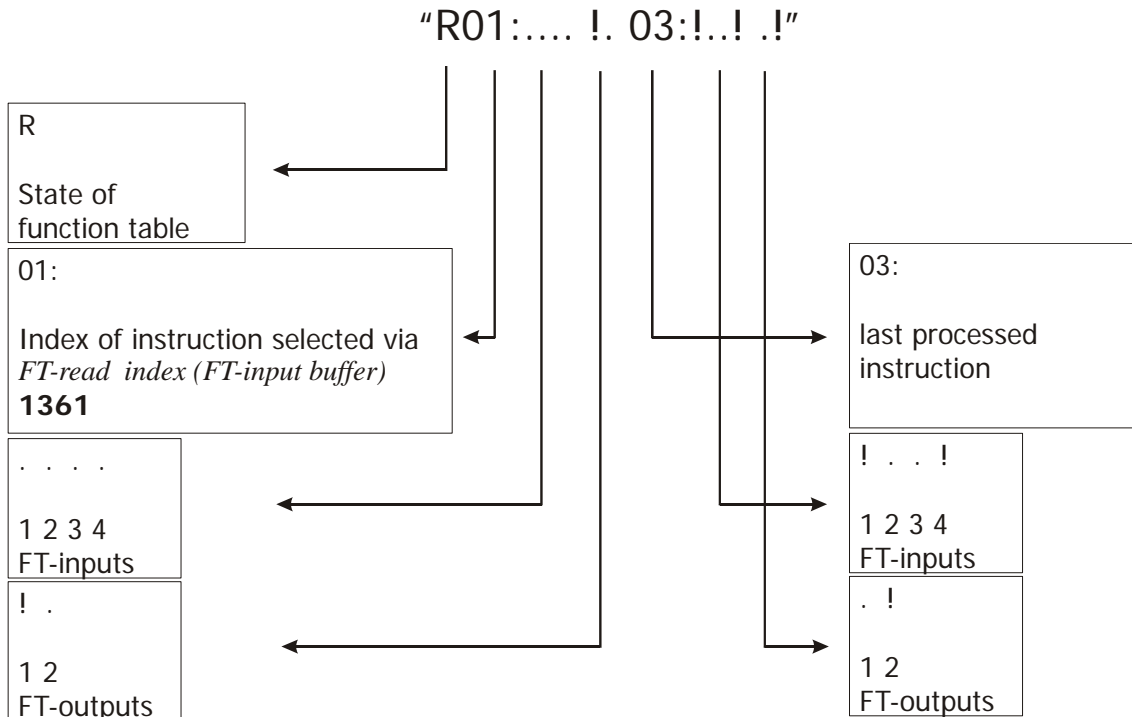

"." = FALSE
 "!" = TRUE

Note:

Further actual values are described in the operating instructions manual of the frequency inverter.

7.2 Actual values of analog functions

The following parameters display the actual values of index 1 ... 4 of the function table input buffer.

Parameter	No.
<i>FT-Act. Val. Freq. from P.1379</i>	1400
<i>FT-Act. Val. Curr. from P.1380</i>	1401
<i>FT-Act. Val. Perc. from P.1381</i>	1402
<i>FT-Act. Val. Volt.rms P.1382</i>	1403
<i>FT-Act. Val. Volt.pk. P.1382</i>	1404
<i>FT-Act. Val. general P.1383</i>	1405
<i>FT-Act. Val.Outp. Freq. 250x</i>	1406

Parameter	No.
<i>FT-Act. Val.Outp. Curr. 251x</i>	1407
<i>FT-Act. Val.Outp. Perc. 252x</i>	1408
<i>FT-Act. Val.Outp. Volt.rms 253x</i>	1409
<i>FT-Act. Val.Outp. Volt.pk. 253x</i>	1410
<i>FT-Act. Val.Outp. general 255x</i>	1411
<i>FT-Act. Val.Marker 256x</i>	1412

7.3 Digital output signals of the function table

The parameters *Op. Mode Digital Output 1 530* of the digital output S1OUTD and *Op. Mode Digital Output 3 532* of the relay output link digital outputs of the device to various functions. The use of the multifunction output MFO1 as digital output requires the selection of "1 - Digital" for *Operation Mode 550* and setting of parameter *Digital Operation 554*.

The following output signals of the function table can be assigned to digital outputs.

Further operation modes are described in the operating instructions manual of the frequency inverter.

Operation Mode 530, 532, 554	Function
0 - Off	Digital output is switched off.
80 - FT-Output Buffer 1	Digital output signal of an instruction. This output signal corresponds to the signal source "2401 - FT-Output Buffer 1". This signal source is the output value of the instruction for which the signal source 2401 is selected. Selection is carried out via parameters <i>FT-target output 1 1350</i> and <i>FT-target output 2 1351</i> .
81 - FT- Output Buffer 2	Digital output signal of an instruction. This output signal corresponds to the signal source "2402 - FT-Output Buffer 2". This signal source is the output value of the instruction for which the signal source 2402 is selected. Selection is carried out via parameters <i>FT-target output 1 1350</i> and <i>FT-target output 2 1351</i> .
82 - FT- Output Buffer 3	Digital output signal of an instruction. This output signal corresponds to the signal source "2403 - FT-Output Buffer 3". This signal source is the output value of the instruction for which the signal source 2403 is selected. Selection is carried out via parameters <i>FT-target output 1 1350</i> and <i>FT-target output 2 1351</i> .
83 - FT- Output Buffer 4	Digital output signal of an instruction. This output signal corresponds to the signal source "2404 - FT-Output Buffer 4". This signal source is the output value of the instruction for which the signal source 2404 is selected. Selection is carried out via parameters <i>FT-target output 1 1350</i> and <i>FT-target output 2 1351</i> .
100, 180 to 183	Operation modes 0 and 80 to 83 inverted (LOW active).

7.4 Analog output signals of the function table

The analog output of the device can signalize the output values of analog instructions.

The use of the multifunction output MFO1 as analog output requires the selection of "2 - Analog" for *Operation Mode 550* and setting of parameter *Analog Operation 553*.

The following output signals of the function table can be assigned to analog outputs.

<i>Analog Operation 553</i>	Function
61 - Abs. Val. FT-Output Percentage 1	Analog output signal of an instruction as absolute value. This output signal corresponds to the signal source "2521 - FT-Output Percentage 1". This signal source is the output value of the instruction for which the signal source 2521 is selected. Selection is carried out via parameters <i>FT-target output 1 1350</i> and <i>FT-target output 2 1351</i> .
62 - Abs. Val. FT-Output Percentage 2	Analog output signal of an instruction as absolute value. This output signal corresponds to the signal source "2522 - FT-Output Percentage 2". This signal source is the output value of the instruction for which the signal source 2522 is selected. Selection is carried out via parameters <i>FT-target output 1 1350</i> and <i>FT-target output 2 1351</i> .

Analog Operation 553	Function
161 - FT-Output Percentage 1	Analog output signal of an instruction. This output signal corresponds to the signal source "2521 - FT-Output Percentage 1". This signal source is the output value of the instruction for which the signal source 2521 is selected. Selection is carried out via parameters <i>FT-target output 1</i> 1350 and <i>FT-target output 2</i> 1351 .
162 - FT-Output Percentage 2	Analog output signal of an instruction. This output signal corresponds to the signal source "2522 - FT-Output Percentage 2". This signal source is the output value of the instruction for which the signal source 2522 is selected. Selection is carried out via parameters <i>FT-target output 1</i> 1350 and <i>FT-target output 2</i> 1351 .

7.5 Logic signal sources of the function table

Signal sources of the function table can be assigned to software functions for further processing. Writing the output buffer updates the values.

Further signal sources are described in the operating instructions manual of the frequency inverter.

Signal source
Digital and analog
2401 - FT-Outp. Buffer 1
2402 - FT- Outp. Buffer 2
2403 - FT- Outp. Buffer 3
2404 - FT- Outp. Buffer 4
2405 - FT- Outp. Buffer 5
2406 - FT- Outp. Buffer 6
.
.
.
2415 - FT-Output Buffer 15
2416 - FT-Output Buffer 16
Analog
2501 ... 2504 - FT-Output Frequency 1 ... FT-Output Frequency 4
2511 ... 2514 - FT-Output Current 1 ... FT-Output Current 4
2521 ... 2524 - FT-Output Percentage 1 ... FT-Output Percentage 4
2531 ... 2534 - FT-Output Voltage 1 ... FT-Output Voltage 4
2551 ... 2554 - FT-Output General value 1 ... FT-Output General value 4
2561 ... 2564 - FT-Marker 1 ... FT-Marker 4

8 State machine operation

In the previous chapters the function table is described as chronological sequence of instructions. Additionally a state machine operation (status automation) can be integrated by means of the defined instructions. State machine operation is most usual for schematic representation of sequences and easy implementation of applications.

Jump functions are especially applicable to realize a state machine. Jump functions are necessary for change of state. Inputs 1 and 2 of the jump function are used for condition verifying of the transition. Inputs 3 and 4 set the input buffer and write the output buffer. Inputs 3 and 4 are usually set to TRUE for updating the signals for change of state.

8.1 Control example

Example:

The function table should control a hoist gear with two positions (top and bottom). The target position can be specified via a toggle switch. An initiator for target signalling is installed on each position. The frequency inverter should stop the drive and switch on LED "top" or LED "bottom" if the target position is reached. The LED should be switched off if the drive restarts.

The door on both positions can be manually opened by the operator. The LED "top" or "bottom" should be pulsating switched on and off in the time period of 100 ms if one of the doors is opened. The signals "Door opened" of both doors must be connected in series.

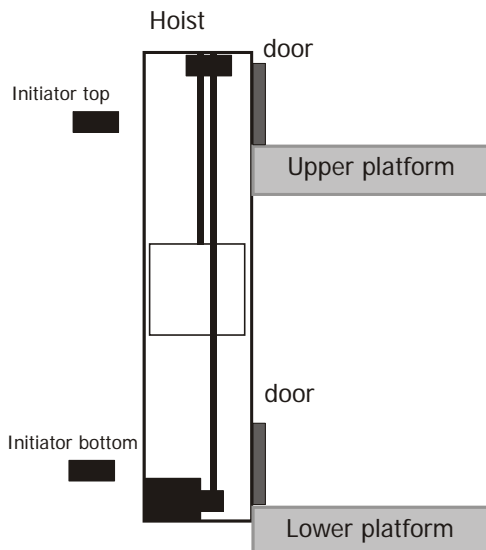

Representation as state machine, step 1

The requirements described above are shown as state machine in the following diagram. For design consider that the state must be initialized first when the ACU is switched on (or reset). Initialization is used to change to the correct state in this example. First the initiators are evaluated. The state is changed if one of the initiators generates a target signal. The hoist gear moves to the bottom position if no initiator signal applies.

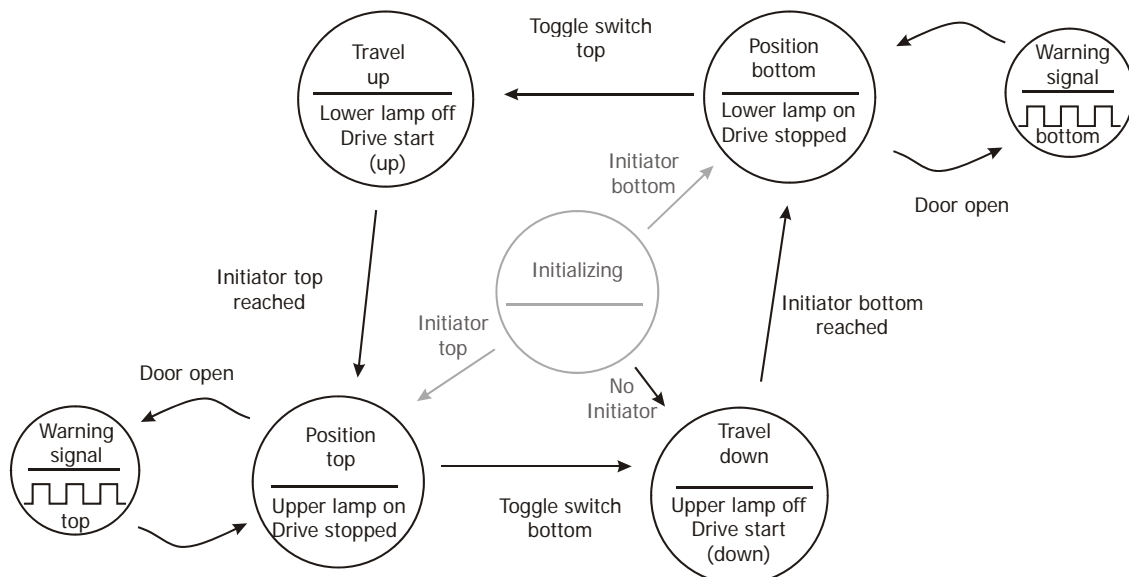

Representation as state machine, step 2

Events and executing are assigned to digital signals of the ACU. Links from input buffer and output buffer to signals are established. An expansion module EM-IO-03 is available.

Function	ACU	Input buffer	Output buffer
Tappet switch (top/bottom)	S5IND (1/0)	2005	
Initiator top (reached/not reached)	S4IND (1/0)	2004	
Initiator bottom (reached/not reached)	S2IND (1/0)	2002	
Door (opened/closed)	S3IND (1/0)	2003	
Lower lamp (on/off)	S1OUTD (1/0)		2401
Upper lamp (on/off)	S3OUTD (1/0)		2402
Warning light door bottom (on/off)	MFO1D (1/0)		2403
Warning light door top (on/off)	EM-S1OUTD (1/0)		2404
Drive start (up)	<i>Start clockwise</i> 068		2410
Drive start (down)	<i>Start Anticlockwise</i> 069		2411

The assignment of digital ACU signals results in the following diagram:

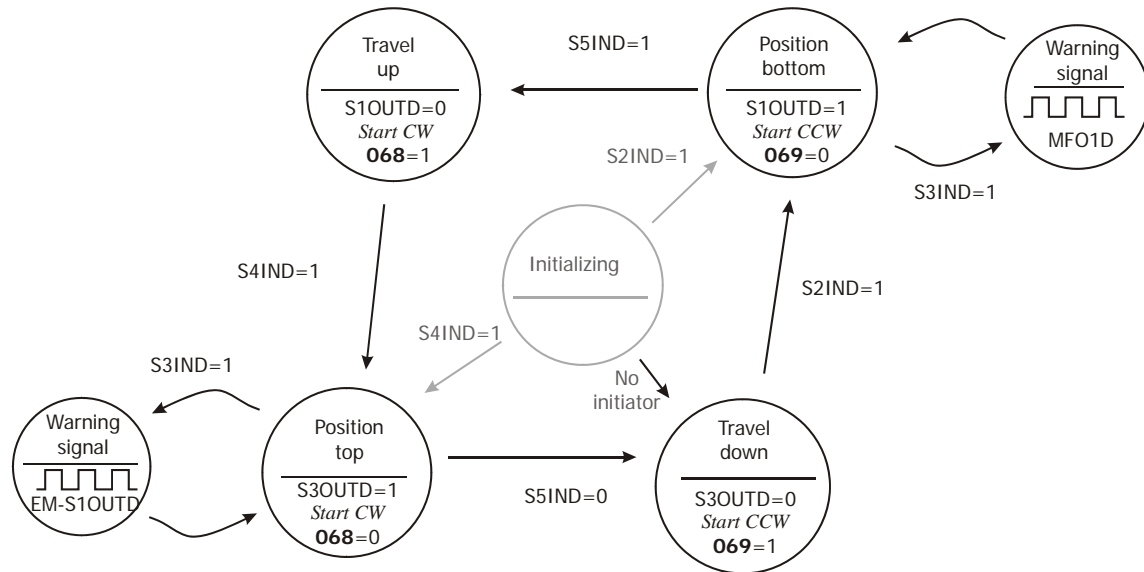

Solution:

Parameterize and assign ACU signals to input buffer of function table

2002: *FT-input buffer 1362*, Index 2 : „71 – S2IND“

2003: *FT-input buffer 1362*, Index 3 : „72 – S3IND“

2004: *FT-input buffer 1362*, Index 4 : „73 – S4IND“

2005: *FT-input buffer 1362*, Index 5 : „74 – S5IND“

2006: *FT-input buffer 1362*, Index 6 : „274 – S5IND inverted“ (*)

(*): Parameterized other than factory setting.

Parameterize and assign output buffer of function table to ACU signals:

Op. Mode Digital Output 1 530 2401 - FT-Output Buffer 1

Op. Mode Digital Output 3 532 2402 - FT-Output Buffer 2

Op. Mode EM-S1OUTD 533 2404 - FT-Output Buffer 4

MFO1: Operation Mode 550 1 - Digital

MFO1: Digital Operation 554 2403 - FT-Output Buffer 3

Start Clockwise 068 2410 - FT-Output Buffer 10

Start Anticlockwise 069 2411 - FT-Output Buffer 11

Signal S5IND is assigned as inverted signal in the input buffer for easy indication of transition "Position top" → "Travel down". For easier parameterization the names and states which have been used until now are replaced by numerical values.

The following diagram is the result of parameterized function table signals:

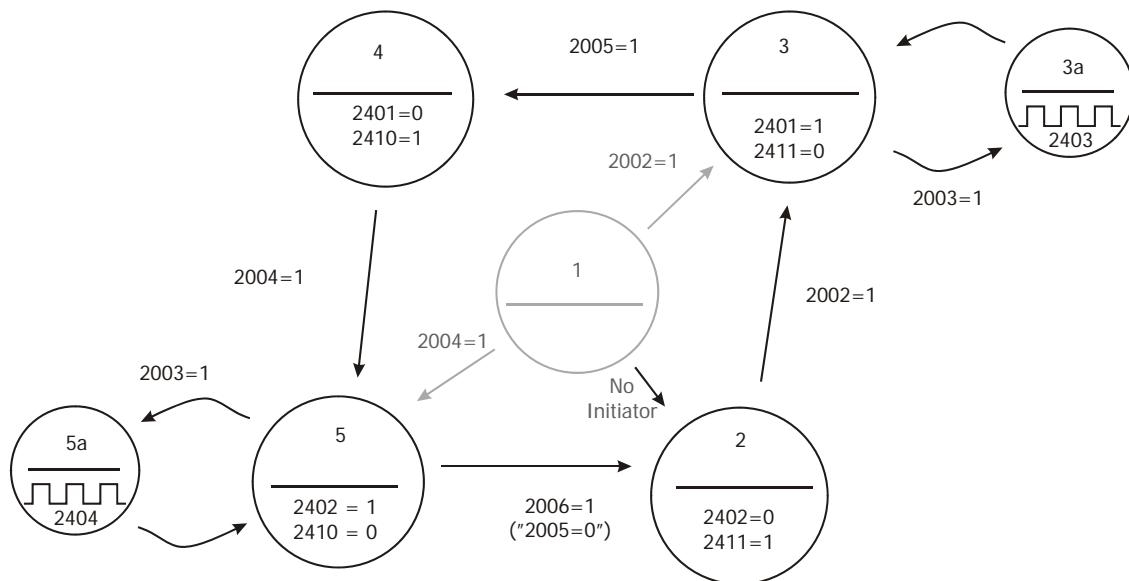

Enter states and transitions into the instructions.

Set state outputs:

Use a Boolean operation to set a digital signal (independent of one or more input signals). An OR-instruction is used in this application and an input is set to TRUE. By that *FT-target output 1 1350* is set to TRUE (=1) and *FT-target output 2 1351* is set to FALSE (=0).

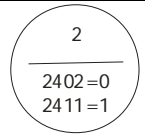
	<i>FT-instruction 1343</i>	2 – OR
	<i>FT-input 1 1344</i>	6 – TRUE
	<i>FT-input 2 1345</i>	7 – FALSE
	<i>FT-input 3 1346</i>	7 – FALSE
	→ <i>FT-input 4 1347</i>	7 – FALSE
	<i>FT-parameter 1 1348</i>	0
	<i>FT-parameter 2 1349</i>	0
	<i>FT-target output 1 1350</i>	2411 – FT-Outp. Buffer 11
<i>FT-target output 2 1351</i>	2402 – FT- FT-Outp. Buffer 2	

Instructions can be accordingly created for states 3 to 5.

Clock generator (state 3a)

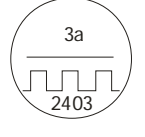
	<i>FT-instruction 1343</i>	80 – Clock Generator Superior ms
	<i>FT-input 1 1344</i>	2003 – FT-Input Buffer 3
	<i>FT-input 2 1345</i>	7 – FALSE
	<i>FT-input 3 1346</i>	7 – FALSE
	→ <i>FT-input 4 1347</i>	7 – FALSE
	<i>FT-parameter 1 1348</i>	100
	<i>FT-parameter 2 1349</i>	100
	<i>FT-target output 1 1350</i>	0
<i>FT-target output 2 1351</i>	0	

The clock generator of state 5 is created according to state 3a.

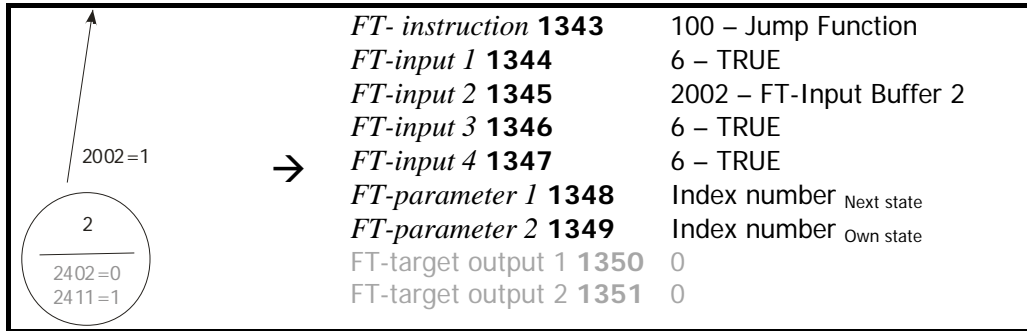
Transition from state 2 to state 3

Entries “Next state” and “Own state” are used as placeholder until the correct numbers of indices can be entered. Transition from state 4 to state 5 can be created accordingly.

Transition from state 3 to state 4

Transition from state 3 to state 4 is different to the previous step because two jump events must be verified.

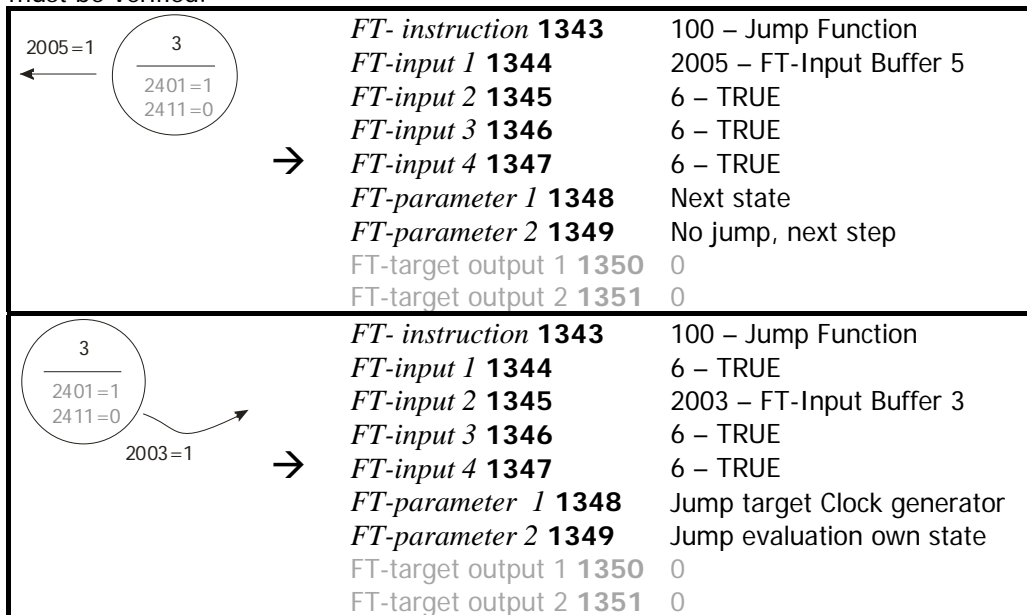

Entries “Next state” and “Jump target Clock generator”, “Jump evaluation own state” are used as placeholder until the correct numbers of indices can be entered. Entry “No jump, next step” is a placeholder for any value. The jump function is only active if “2005 – FT-Input Buffer 5” is TRUE (DI5=0). Otherwise the next step is processed. Transition from state 5 to state 2 can be accordingly created.

Initialization

Initialization is a jump function with three targets. Therefore two jump functions are necessary. Initialization must start in Index 1 because the function table starts with index 1 after a restart.

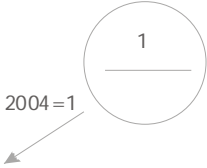
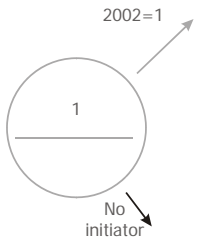
	FT-instruction 1343 100 – Jump Function FT-input 1 1344 2004 – FT-Input Buffer 4 FT-input 2 1345 6 – TRUE FT-input 3 1346 6 – TRUE FT-input 4 1347 6 – TRUE FT-parameter 1 1348 Jump target state 5 FT-parameter 2 1349 No jump, next step FT-target output 1 1350 0 FT-target output 2 1351 0
	FT-instruction 1343 100 – Jump Function FT-input 1 1344 6 – TRUE FT-input 2 1345 2002 – FT-Input Buffer 2 FT-input 3 1346 6 – TRUE FT-input 4 1347 6 – TRUE FT-parameter 1 1348 Jump target state 3 FT-parameter 2 1349 Jump target state 2 FT-target output 1 1350 0 FT-target output 2 1351 0

All blocks are defined. The blocks must be entered into the table and the placeholders must be replaced by indices. The states are colored differently. Not relevant entries are slightly colored.

	Index 1	Index 2
FT-instruction 1343	100 – Jump Function	100 – Jump Function
FT-input 1 1344	2004 – FT-Input Buffer 4	6 – TRUE
FT-input 2 1345	6 – TRUE	2002 – FT-Input Buffer 2
FT-input 3 1346	6 – TRUE	6 – TRUE
FT-input 4 1347	6 – TRUE	6 – TRUE
FT-parameter 1 1348	11	5
FT-parameter 2 1349	2	3
FT-target output 1 1350	0	0
FT-target output 2 1351	0	0
FT-commentary 1352	Init 1	Init 2





	Index 3	Index 4
FT-instruction 1343	2 – ODER	100 – Jump Function
FT-input 1 1344	6 – TRUE	6 – TRUE
FT-input 2 1345	7 – FALSE	2002 – FT-Input Buffer 2
FT-input 3 1346	7 – FALSE	6 – TRUE
FT-input 4 1347	7 – FALSE	6 – TRUE
FT-parameter 1 1348	0	5
FT-parameter 2 1349	0	4
FT-target output 1 1350	2411 FT-Output Buffer 11	0
FT-target output 2 1351	2402 FT-Output Buffer 2	0
FT-commentary 1352	Z2: 2411=1	Z2 --> Z3

	Index 5	Index 6
FT-instruction 1343	2 – ODER	80 – Takterzeuger
FT-input 1 1344	6 – TRUE	2003 – FT-Input Buffer 3
FT-input 2 1345	7 – FALSE	7 – FALSE
FT-input 3 1346	7 – FALSE	7 – FALSE
FT-input 4 1347	7 – FALSE	7 – FALSE
FT-parameter 1 1348	0	100
FT-parameter 2 1349	0	100
FT-target output 1 1350	2401 FT-Output Buffer 1	2403 FT-Output Buffer 3
FT-target output 2 1351	2411 FT-Output Buffer 11	0
FT-commentary 1352	Z3: 2401=1	Z3a: Takt

<i>FT-instruction</i> 1343 <i>FT-input 1</i> 1344 <i>FT-input 2</i> 1345 <i>FT-input 3</i> 1346 <i>FT-input 4</i> 1347 <i>FT-parameter 1</i> 1348 <i>FT-parameter 2</i> 1349 <i>FT-target output 1</i> 1350 <i>FT-target output 2</i> 1351 <i>FT-commentary</i> 1352	Index 7 100 – Jump Function 2005 – FT-Input Buffer 5 6 – TRUE 6 – TRUE 6 – TRUE 9 8 0 0 Z3 --> Z4	Index 8 100 – Jump Function 6 – TRUE 2003 – FT-Input Buffer 3 6 – TRUE 6 – TRUE 6 7 0 0 Z3 -> Z4
<i>FT-instruction</i> 1343 <i>FT-input 1</i> 1344 <i>FT-input 2</i> 1345 <i>FT-input 3</i> 1346 <i>FT-input 4</i> 1347 <i>FT-parameter 1</i> 1348 <i>FT-parameter 2</i> 1349 <i>FT-target output 1</i> 1350 <i>FT-target output 2</i> 1351 <i>FT-commentary</i> 1352	Index 9 2 – ODER 6 – TRUE 7 – FALSE 7 – FALSE 7 – FALSE 0 0 2410 FT-Output Buffer 10 2401 FT-Output Buffer 1 Z4: 2410=1	Index 10 100 – Jump Function 6 – TRUE 2002 – FT-Input Buffer 2 6 – TRUE 6 – TRUE 11 10 0 0 Z4 --> Z5
<i>FT-instruction</i> 1343 <i>FT-input 1</i> 1344 <i>FT-input 2</i> 1345 <i>FT-input 3</i> 1346 <i>FT-input 4</i> 1347 <i>FT-parameter 1</i> 1348 <i>FT-parameter 2</i> 1349 <i>FT-target output 1</i> 1350 <i>FT-target output 2</i> 1351 <i>FT-commentary</i> 1352	Index 11 2 – ODER 6 – TRUE 7 – FALSE 7 – FALSE 7 – FALSE 0 0 2401 FT-Output Buffer 1 2411 FT-Output Buffer 11 Z5: 2401=1	Index 12 80 – Takterzeuger 2003 – FT-Input Buffer 3 7 – FALSE 7 – FALSE 7 – FALSE 100 100 2404 FT-Output Buffer 4 0 Z5a: Takt
<i>FT-instruction</i> 1343 <i>FT-input 1</i> 1344 <i>FT-input 2</i> 1345 <i>FT-input 3</i> 1346 <i>FT-input 4</i> 1347 <i>FT-parameter 1</i> 1348 <i>FT-parameter 2</i> 1349 <i>FT-target output 1</i> 1350 <i>FT-target output 2</i> 1351 <i>FT-commentary</i> 1352	Index 13 100 – Jump Function 2006 – FT-Input Buffer 6 6 – TRUE 6 – TRUE 6 – TRUE 3 14 0 0 Z5 --> Z2	Index 14 100 – Jump Function 6 – TRUE 2003 – FT-Input Buffer 3 6 – TRUE 6 – TRUE 12 13 0 0 Z5 -> Z2

9 Parameter List

The parameter list is structured according to the menu branches of the control unit. The parameters are listed in ascending numerical order. A headline (shaded) can appear several times, i.e. a subject area may be listed at different places in the table. For better clarity, the parameters have been marked with pictograms:

-  The parameter is available in the four data sets.
-  The parameter value is set by the SETUP routine.
-  This parameter cannot be written when the frequency inverter is in operation.
-  This parameter can only be written in the setting *FT-RunMode* **1399** = "0 - Stop".

I_{FUN} , U_{FUN} , P_{FUN} : rated values of the frequency inverter, \ddot{u} : overload capacity of frequency inverter





Note:





In the KP500 control unit, parameter numbers > 999 are represented in hexadecimal form (999, A00 ... B54 ... C66 ...).

9.1 Actual Value Menu (VAL)

Function Table				
No.	Description	Unit	Display range	Chapter
1356	FT-actual values function	-	X01:..... .. 01:.... ..to X32:!!!! !! 32:!!!! !!	7.1
1357	FT-actual values output buffer	- to !!!! !!!! !!!! !!!!	7.1
1358	FT-actual values input buffer	- to !!!! !!!! !!!! !!!!	7.1
1400	FT-Act. Val. Freq. from P.1379	Hz	0.00 ... 999.99	7.2
1401	FT-Act. Val. Curr. from P.1380	A	0.0 ...	7.2
1402	FT-Act. Val. Perc. from P.1381	%	0.00 ...	7.2
1403	FT-Act. Val. Volt.rms P.1382	V	0.0 ...	7.2
1404	FT-Act. Val. Volt.pk. P.1382	V	0.0 ...	7.2
1405	FT-Act. Val. general P.1383	-	0 ...	7.2
1406	FT-Act. Val.Outp. Freq. 250x	Hz	0.00 ...	7.2
1407	FT-Act. Val.Outp. Curr. 251x	A	0.0 ...	7.2
1408	FT-Act. Val.Outp. Perc. 252x	%	0.00 ...	7.2
1409	FT-Act. Val.Outp. Volt.rms 253x	V	0.0 ...	7.2
1410	FT-Act. Val.Outp. Volt.pk. 253x	V	0.0 ...	7.2

9.2 Parameter Menu (PARA)

Function Table					
No.	Description	Unit	Setting range	Fact. sett.	Chapter
1341	FT-write index (FT-table item)	-	0 ... 65	1	3.1.1
1342	FT-read index (FT-table item)	-	0 ... 65	1	3.1.1
 1343	FT-instruction	-	Selection	0 - Off (last table item)	3.5
 1344	FT-input 1	-	Selection	7 - FALSE	3.6
 1345	FT-input 2	-	Selection	7 - FALSE	3.6
 1346	FT-input 3	-	Selection	7 - FALSE	3.6
 1347	FT-input 4	-	Selection	7 - FALSE	3.6

Function Table					
No.	Description	Unit	Setting range	Fact. sett.	Chapter
	1348 FT-parameter 1	Depends on instruction	0 ... 65535	10	3.7, 5.1
	1349 FT-parameter 2		0 ... 65535	10	3.7, 5.1
	1350 FT-target output 1	-	Selection	0 - Output not globally useable	0
	1351 FT-target output 2	-	Selection	0 - Output not globally useable	0
	1352 FT-commentary	-	16 characters	-	3.4
Function Table: Input Buffer					
	1360 FT-write index (FT-input buffer)	-	0 ... 33	1	3.1.3
	1361 FT-read index (FT-input buffer)	-	0 ... 33	1	3.1.3
	1362 FT-input buffer	-	Selection	7 - Off	3.1.3
Function Table Input Buffer analog					
	1377 FT-write index (FT-input analog)	-	0 ... 9	1	3.1.2
	1378 FT-read index (FT-input analog)	-	0 ... 9	1	3.1.2
	1379 FT-input buffer frequency	-	Selection	9 - Zero	2.6
	1380 FT-input buffer current	-	Selection	9 - Zero	2.6
	1381 FT-input buffer percentage	-	Selection	9 - Zero	2.6
	1382 FT-input buffer voltage	-	Selection	9 - Zero	2.6
	1383 FT-input buffer gen. source	-	0 ... 2147483647	9	2.6
	1384 numerator gen. source inp. 1383	%	-327.68 ... 327.67	100.00	2.6
	1385 denomin. gen. source inp. 1383	%	0.01 ... 327.67	100.00	2.6
	1386 numerator gen. source outp. 2551	%	-327.68 ... 327.67	100.00	2.6
	1387 denomin. gen. source outp. 2551	%	0.01 ... 327.67	100.00	2.6
	1388 FT-fixed value frequency	Hz	-999.99 ... 999.99	50.00	2.6
	1389 FT-fixed value current	A	$-I_{max} \dots I_{max}$	I_{Rated}	2.6
	1390 FT-fixed value percentage	%	-327.67 ... 327.67	100.00	2.6
	1391 FT-fixed value voltage	V	-1000.0 ... 1000.0	565.7	2.6
	1392 FT-fixed value position	units	-2147483647 ... 2147483647	65536	2.6
	1393 FT-fixed value speed Pos.	u/s	-2147483647 ... 2147483647	163840	2.6
	1394 FT-fixed value ramp Pos.	u/s ²	1 ... 2147483647	327680	2.6
	1395 FT-fixed value general	-	-32767 ... 32767	0	2.6
	1396 numerator fixed value gen. 1395	%	-327.68 ... 327.67	100	2.6
	1397 denomin. fixed value gen. 1395	%	0.01 ... 327.67	100	2.6
Function table					
	1399 FT-RunMode	-	Selection	0 - Stop	3.3

10 Annex

10.1 Mask: Functions diagram

FT-input buffer 1362		Index 1	Index 2	Index 3	Index 4	Index 5	Index 6	Index 7	Index 8	Index 9	Index 10	Index 11	Index 12	Index 13	Index 14	Index 15	Index 16
Source:		2001	2002	2003	2004	2005	2006	2007	2008	2009	2010	2011	2012	2013	2014	2015	2016
Factory setting:		70 - Inverter release	71 - S2IND	72 - S3IND	73 - S4IND	74 - S5IND	75 - S6IND	76 - MF11D	7 - Off	7 - Off	7 - Off	160 - Standby message	161 - Run message	162 - Error signal	163 - Reference frequency reached	7 - Off	7 - Aus
Changed setting:																	

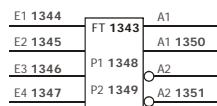
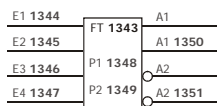
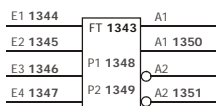
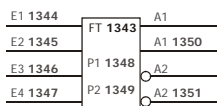
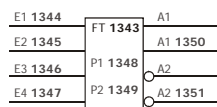
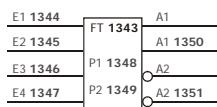
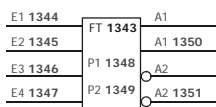
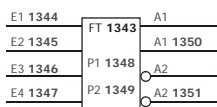
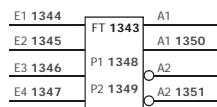
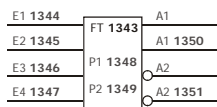
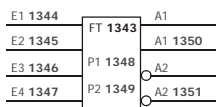
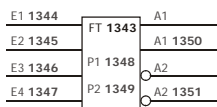
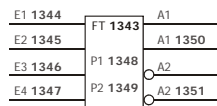
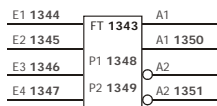
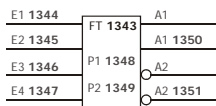
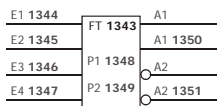
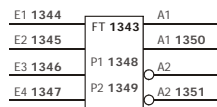
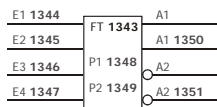
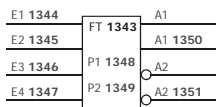
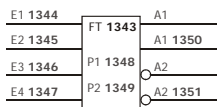
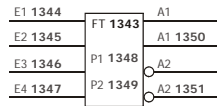
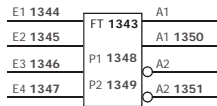
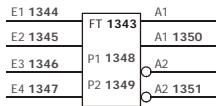
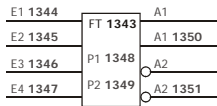

FT-output buffer		Index 1	Index 2	Index 3	Index 4	Index 5	Index 6	Index 7	Index 8	Index 9	Index 10	Index 11	Index 12	Index 13	Index 14	Index 15	Index 16
Source:		2401	2402	2403	2404	2405	2406	2407	2408	2409	2410	2411	2412	2413	2414	2415	2416
Digitaler output:																	

10.2 Mask: Functions settings

		1	2	3	4	5	6	7	8
FT-instruction	1343								
FT-input 1	1344								
FT-input 2	1345								
FT-input 3	1346								
FT-input 4	1347								
FT-parameter 1	1348								
FT-parameter 2	1349								
FT-target output 1	1350								
FT-target output 2	1351								
FT-commentary	1352								

		9	10	11	12	13	14	15	16
FT-instruction	1343								
FT-input 1	1344								
FT-input 2	1345								
FT-input 3	1346								
FT-input 4	1347								
FT-parameter 1	1348								
FT-parameter 2	1349								
FT-target output 1	1350								
FT-target output 2	1351								
FT-commentary	1352								

		17	18	19	20	21	22	23	24
FT-instruction	1343								
FT-input 1	1344								
FT-input 2	1345								
FT-input 3	1346								
FT-input 4	1347								
FT-parameter 1	1348								
FT-parameter 2	1349								
FT-target output 1	1350								
FT-target output 2	1351								
FT-commentary	1352								

		25	26	27	28	29	30	31	32
FT-instruction	1343								
FT-input 1	1344								
FT-input 2	1345								
FT-input 3	1346								
FT-input 4	1347								
FT-parameter 1	1348								
FT-parameter 2	1349								
FT-target output 1	1350								
FT-target output 2	1351								
FT-commentary	1352								

Index

- A**
- Absolute value..... 109
 - Actual values..... 150
 - Add 2 Bits to 1 Word..... 144
 - Addition..... 100
 - Long..... 101
 - Analog Switch..... 120
 - Analogue Hysteresis..... 94
 - Analogue Multiplexer (data set no.)..... 119
 - AND-operation..... 56
 - Average function..... 106
- B**
- Bit-functions for analog input values..... 137
 - Add 2 Bits to 1 Word..... 144
 - Bit arithm. Shift Right..... 141
 - Bit by Bit AND/NAND..... 138
 - Bit by Bit NOT..... 137
 - Bit by Bit OR/NOR..... 139
 - Bit by Bit XOR/XNOR..... 140
 - Bit Roll right..... 142
 - Bit Shift left..... 142
 - Bit Shift right..... 141
 - Merge 4 Bits to 1 Word..... 143
 - Output 1 Bit..... 143
 - Boolean operations..... 56
- C**
- Check state..... 136
 - Clock generator
 - Master..... 81
 - Superior..... 80
 - Clock with analogue output..... 131
 - Comment field..... 29
 - Commissioning..... 20
 - Comparator..... 90
 - Active motion block..... 92
 - Constant-Variable..... 91
 - Position..... 93
 - Variables..... 90
 - Window-comparator
 - Constant-Variable..... 95
 - Variables..... 94
 - Counter
 - Clock with analogue output..... 131
 - Up/Down Counter with analogue output..... 130
- D**
- Debouncer..... 86
 - Delay..... 67
 - Master
 - not retriggerable..... 73
 - retriggerable..... 71
 - Superior
 - not retriggerable..... 72
 - retriggerable..... 70
 - D-Flip-Flop
 - Master..... 66
 - Superior..... 65
 - Differentiator..... 108
 - Digital Multiplexer (data set number)..... 82
- Division
 - Constant/Variable..... 105
 - Variable/Constant..... 104
 - Variables..... 104
- E**
- Examples
 - Link of FT-instruction input to digital input..... 43
 - Link of FT-instruction input to FT-instruction output..... 46, 47
 - Link of FT-instruction input to signal source..... 43
 - Link of FT-instruction output to device function..... 49
 - Link of several FT-instructions..... 146
 - Link two digital inputs..... 146
 - Parameterization of logic diagram..... 149
 - RUN/STOP..... 28
 - Signal source for digital output..... 50
 - Exponentiate..... 109, 110
- F**
- Filter
 - PT1-element..... 115
 - Spike-filter..... 118
 - FT-inputs..... 40
 - FT-parameter..... 53, 89
 - Clock generator..... 54
 - Delay..... 54
 - Jump function..... 54
 - Monoflop..... 54
 - Overview table, digital functions..... 55
 - FT-target output..... 42, 47
 - Function table Run/Stop..... 27
 - Functions overview..... 29
- G**
- Global sources..... 47
- I**
- Input buffer
 - analog..... 17
 - digital..... 16
 - Inputs
 - analog..... 37
 - digital..... 36
 - Integrator..... 107
- J**
- Jump function..... 87
 - for loops..... 88
 - Jump target..... 54
- L**
- Limiter
 - Constant..... 128
 - Variable..... 129
 - Linking
 - FT-input buffer and FT-inputs..... 42
 - FT-output buffer..... 47
 - Inputs and outputs of FT-instructions.. 40
 - Instructions to one another (FT-Input). 45
 - output buffer and device function..... 48
 - output buffer and digital output..... 50

Logic signal sources	153	frequency parameter	126
M		long parameter	128
Master	52	percentage parameter	127
Merge 4 Bits to 1 Word	143	position parameter	127
Min/Max.....	96	voltage p. (eff.)	126
for position values	97	voltage p. (peak)	127
for positions in time window.....	98	word parameter	128
in time window.....	98	Read index	
Monoflop		FT-instructions.....	20
Master		Input buffer.....	22
not retriggerable	78	Reset a fault	85
retriggerable).....	76	Root.....	110
Superior		RS-Flip-Flop	
not retriggerable	77	Master	62
retriggerable.....	75	Superior	60
Motion Block		Run/Stop.....	27
Continue.....	135	S	
Interrupt.....	134	Safety instructions.....	2
Resume	135	Spike-Filter (Middle of three)	118
Multiplexer	120	SQRT(X)	110
Multiplication.....	102	Start Homing	136
and Division	105	Start Motion Block	
Long*Percent.....	103	Automatic mode.....	133
result Long	102	Single mode	132
with fraction	103	Statemachine.....	154
MUX for position values.....	120	Superior	52
N		Switch Data Set.....	83
NOP	86	Switch for position values.....	121
O		Switching time	67
OR-operation.....	57	System description	10
Output 1 Bit	143	T	
Output buffer		Time average.....	116
analog.....	17	Timer functions	75
digital.....	16	Toggle-Flip-Flop	
Output signals	150	Master	64
analog.....	37, 152	Superior	63
digital.....	152	Transport and storage	3
P		Trigger a fault	84
Parameter list.....	161	U	
P-Controller.....	111	Up/Down Counter with analogue output	130
PD(T1)-Controller	112	V	
PI-Controller		Value of three orthogonal components..	107
Tn in milliseconds.....	111	Value of two orthogonal components	106
Tn in seconds.....	112	VTable.....	24
PID(T1)-Controller		W	
Tn in milliseconds.....	113	Window-comparator	
Tn in seconds.....	114	Constant-Variable.....	95
Positioning functions	132	Variables	94
Check state.....	136	Write	
Motion Block		current parameter	122
Continue	135	frequency parameter	122
Interrupt	134	long parameter	125
Resume.....	135	percentage parameter	124
Start Homing	136	position parameter	124
Start Motion Block		voltage p. (eff.)	123
Automatic mode.....	133	voltage p. (peak)	123
Single mode	132	word parameter	125
PT1-element	115	Write index	
R		FT-instructions.....	20
Ramp limiter	117	Input buffer.....	22
Read			
current parameter	126		

X		XOR 1 3-operation	59
X ² 109	XOR 1-operation	58
X ³ 110		



Bonfiglioli Worldwide & BEST Partners

AUSTRALIA

BONFIGLIOLI TRANSMISSION (Aust) Pty Ltd.
101, Plumpton Road, Glendenning NSW 2761, Australia
Locked Bag 1000 Plumpton NSW 2761
Tel. (+ 61) 2 8811 8000 - Fax (+ 61) 2 9675 6605
www.bonfiglioli.com.au - sales@bonfiglioli.com.au

AUSTRIA **BEST**

MOLL MOTOR GmbH
Industriestrasse 8 - 2000 Stockerau
Tel. (+43) 2266 63421+DW - Fax (+43) 6342 180
www.mollmotor.at - office@mollmotor.at

BELGIUM **BEST**

ESCO TRANSMISSION N.V./S.A.
Culliganlaan 3 - 1831 Machelem Diegem
Tel. (+32) 2 7176460 - Fax (+32) 2 7176461
www.esco-transmissions.be - info@esco-transmissions.be

BRASIL **BEST**

ATI BRASIL
Rua Omlio Monteiro Soares, 260 - Vila Fanny - 81030-000
Tel. (+41) 334 2091 - Fax (+41) 332 8669
www.atibrasil.com.br - vendas@atibrasil.com.br

CANADA

BONFIGLIOLI CANADA INC.
2-7941 Janie Street - Concord, ONTARIO L4K 4L6
Tel. (+1) 905 7384466 - Fax (+1) 905 7389833
www.bonfigliolicanada.com - sales@bonfigliolicanada.com

CHINA

BONFIGLIOLI DRIVES (SHANGHAI) CO. LTD.
No. 8 Building, 98 Tian Ying Road
Qingpu District, Shanghai, PRC 201712
Tel. +86 21 69225500 - Fax +86 21 69225511
www.bonfiglioli.cn - bds@bonfiglioli.com.cn

FRANCE

BONFIGLIOLI TRANSMISSIONS S.A.
14 Rue Eugène Pottier BP 19
Zone Industrielle de Moimont II - 95670 Marly La Ville
Tel. (+33) 1 34474510 - Fax (+33) 1 34688800
www.bonfiglioli.fr - btf@bonfiglioli.fr

GERMANY

BONFIGLIOLI DEUTSCHLAND GmbH
Sperberweg 12 - 41468 Neuss
Tel. (+49) 02131 2988-0 - Fax (+49) 02131 2988-100
www.bonfiglioli.de - info@bonfiglioli.de

GREAT BRITAIN

BONFIGLIOLI UK Ltd
Industrial Equipment - Unit 3 Colemeadow Road
North Moons Moat - Redditch, Worcestershire B98 9PB
Tel. (+44) 1527 65022 - Fax (+44) 1527 61995
www.bonfiglioli-uk.com - uksales@bonfiglioli-uk.com

Mobile Equipment
5 Grosvenor Grange - Woolston - Warrington, Cheshire WA1 4SF
Tel. (+44) 1925 852667 - Fax (+44) 1925 852668
www.bonfiglioli-uk.com - salesmobile@bonfiglioli-uk.com

GREECE **BEST**

B.E.S.T. HELLAS S.A.
O.T. 48A T.O. 230 - C.P. 570 22 Industrial Area - Thessaloniki
Tel. (+30) 2310 796456 - Fax (+30) 2310 795903
www.bonfiglioli.gr - info@bonfiglioli.gr

HOLLAND **BEST**

ELSTO AANDRIJFTECHNIEK
Loostenweg, 7 - 2215 TL Voorhout
Tel. (+31) 252 219 123 - Fax (+31) 252 231 660
www.elsto.nl - imfo@elsto.nl

HUNGARY **BEST**

AGISYS AGITATORS & TRANSMISSIONS Ltd
2045 Törökbálint, Tó u.2. Hungary
Tel. +36 23 50 11 50 - Fax +36 23 50 11 59
www.agisys.hu - info@agisys.hu

INDIA

BONFIGLIOLI TRANSMISSIONS PVT Ltd.
PLOT AC7-AC11 Sidco Industrial Estate
Thirumudivakkam - Chennai 600 044
Tel. +91(0)44 24781035 / 24781036 / 24781037
Fax +91(0)44 24780091 / 24781904
www.bonfiglioli.co.in - bonfig@vsnl.com

ITALY

BONFIGLIOLI ITALIA S.p.A.
Via Sandro Pertini lotto 7b - 20080 Carpiano (Milano)
Tel. (+39) 02 985081 - Fax (+39) 02 985085817
www.bonfiglioli.it - customerservice.italia@bonfiglioli.it

NEW ZEALAND **BEST**

SAECO BEARINGS TRANSMISSION
36 Hastie Avenue, Mangere
Po Box 22256, Otahuhu - Auckland
Tel. +64 9 634 7540 - Fax +64 9 634 7552
mark@saeco.co.nz

POLAND **BEST**

POLPACK Sp. z o.o. - Ul. Chrobrego 135/137 - 87100 Torun
Tel. (+48) 56 6559235 - 6559236 - Fax (+48) 56 6559238
www.polpack.com.pl - polpack@polpack.com.pl

PORTUGAL **BEST**

BT BONFITEC Equipamentos Industriais, Lda.
Largo do Colegio de Ermesinde, 70 - Formiga 4445-382 Ermesinde
Tel. (+351) 229759634/5/6 - Fax (+351) 229752211
www.bonfitec.pt - bonfitec@bonfitec.pt

RUSSIA **BEST**

FAM
57, Maly prospekt, V.O. - 199048, St. Petersburg
Tel. +7 812 3319333 - Fax +7 812 3271454
www.fam-drive.ru - info@fam-drive.ru

SPAIN

TECNOTRANS BONFIGLIOLI S.A.
Pol. Ind. Zona Franca sector C, calle F, nº6 08040 Barcelona
Tel. (+34) 93 4478400 - Fax (+34) 93 3360402
www.tecnotrans.com - tecnotrans@tecnotrans.com

SOUTH AFRICA

BONFIGLIOLI POWER TRANSMISSION Pty Ltd.
55 Galaxy Avenue, Linbro Business Park - Sandton
Tel. (+27) 11 608 2030 OR - Fax (+27) 11 608 2631
www.bonfiglioli.co.za - bonfigsales@bonfiglioli.co.za

SWEDEN

BONFIGLIOLI SKANDINAVIEN AB
Koppargatan 8 - 234 35 Lomma, Sweden
Tel. (+46) 40418230 - Fax (+46) 40414508
www.bonfiglioli.se - info@bonfiglioli.se

THAILAND **BEST**

K.P.T MACHINERY (1993) CO.LTD.
259/83 Soi Phiboovues, Sukhumvit 71 Rd. Phrakonong-nur,
Wattana, Bangkok 10110
Tel. 0066.2.3913030/7111998
Fax 0066.2.7112852/3811308/3814905
www.kpt-group.com - sales@kpt-group.com

USA

BONFIGLIOLI USA INC
3541 Hargrave Drive Hebron, Kentucky 41048
Tel.: (+1) 859 334 3333 - Fax: (+1) 859 334 8888
www.bonfiglioliusa.com
industrialsales@bonfiglioliusa.com
mobilesales@bonfiglioliusa.com

VENEZUELA **BEST**

MAICA SOLUCIONES TECNICAS C.A.
Calle 3B - Edif. Comindu - Planta Baja - Local B
La Urbina - Caracas 1070
Tel. (+58) 212 2413570 / 2425268 / 2418263
Fax (+58) 212 2424552 - Tlx 24780 Maica V
maica1@cantv.net

HEADQUARTERS

BONFIGLIOLI RIDUTTORI S.p.A.
Via Giovanni XXIII, 7/A
40012 Lippo di Calderara di Reno
Bologna (ITALY)
Tel. (+39) 051 6473111
Fax (+39) 051 6473126
www.bonfiglioli.com
bonfiglioli@bonfiglioli.com

SPARE PARTS BONFIGLIOLI

B.R.T.
Via Castagnini, 2-4
Z.I. Bargellino - 40012
Calderara di Reno - Bologna (ITALY)
Tel. (+39) 051 727844
Fax (+39) 051 727066
www.brtbonfigliolicambi.it
brt@bonfiglioli.com



ACTIVE Cube

The image shows four industrial motor units of the ACTIVE Cube series, arranged in a row. They are set against a background of a grid and binary code (0s and 1s). The text 'ACTIVE Cube' is overlaid on the image in a white, bold font.

www.bonfiglioli.com

 **BONFIGLIOLI**

The logo consists of a stylized 'B' symbol inside a circle, followed by the word 'BONFIGLIOLI' in a bold, sans-serif font.