

EN 50155 GigE Routing Switch

Viper-212-T3G



- Compact rail-approved Ethernet switch solution
 - Single model 24 – 110VDC power range
 - 3 GigE + 9x100 Mbit/s ports
 - WeOS – Layer 3 switch and router functions
- Externally tested and verified to EN 50155
 - Surge resistance and isolation
 - Magnetic field immunity & conducted emission
 - Shock and vibration
- Designed for long life and extreme operational environments
 - IP67 anti-condensation GORE-TEX® membrane
 - Ambient temperature –40°C (-40°F) to +70°C (+158°F)
 - Integrated M12 threading & high MTBF, 484,000 hours
- Design and production testing to match requirements for train control
 - Post production testing exceeding EN 50155 mandatory requirement
 - Burn in and isolation test on all units
 - Manufactured according to IPC-A-610D class2



EN 50121-4
Railway Trackside

EN 50155
On Board Rail

EN 61000-6-1
Residential Immunity

EN 61000-6-2
Industrial Immunity

EN 61000-6-3
Residential Emission

EN 61000-6-4
Industrial Emission

The Viper-212-T3G is a managed 12 port routing switch designed to meet the full requirements of the rail vehicle market. The incredibly compact and robust housing ensures the unit can be built into tight and environmentally hostile spaces. The Westermo WeOS operating system provides an extensive suite of IP networking standards allowing resilient and flexible networks to be created, meeting the needs of the rail market.

As is critical for all equipment to be installed in rail vehicles, the Viper has been externally tested across the complete spectrum of standards required by EN 50155.

Westermo understand that systems on railcars are required by the EN 50155 standard to have a useful life of 20 years, so as well as using the highest quality components to deliver extended MTBF figures, we also implement features like the GORE-TEX® membrane in the IP67 enclosure to prevent water build up in the units. Due to the high vibration environment of the rail industry, we have also developed the Viper case with integral threading for the M12 connectors to ensure the IP67 seal is maintained for the life of the product.

The EN 50155 standard requires mandatory performance and isolation testing. Not only does Westermo meet these, we exceed them in order to meet the additional manufacturer requirements for train control. Westermo's Swedish factory has been building Ethernet switches for the railcar market for many years and fully understands the measures that are required to provide the highest quality manufactured solutions.

Meeting the requirements of the railcar environment, makes the Viper very well suited for deployment in any application with severe operating conditions and extreme environments.

Ordering Information

Art.no	Description
3641-0550	Viper-212-T3G, Managed EN 50155 GigE switch with routing functionality
3641-0190	M12 USB memory
3146-11xx	Patch and power cables, see www.westermo.com

Specifications Managed EN 50155 GigE switch with routing functionality – Viper 212-T3G

Dimensional drawing

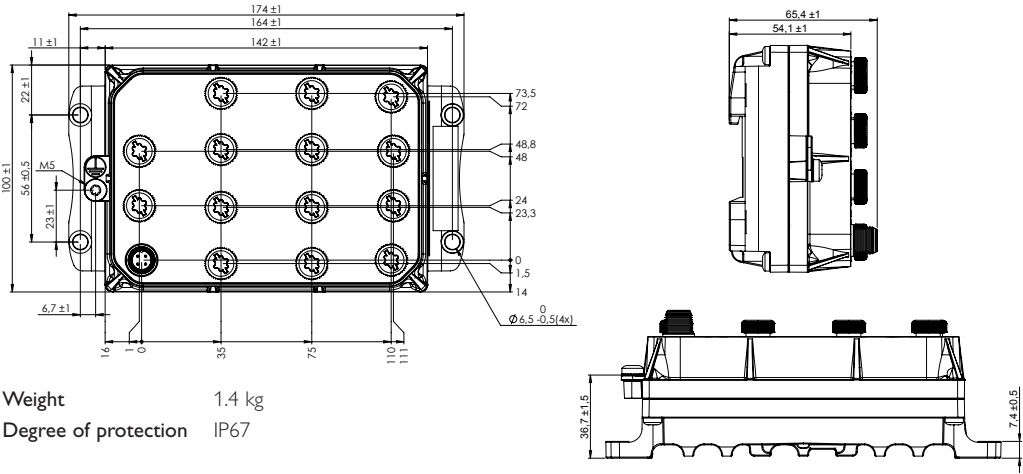

Weight 1.4 kg
 Degree of protection IP67

Power	
Rated voltage	24 to 110 VDC
Operating voltage	16.8 to 143 VDC (14.4 to 154 VDC for 100 ms)
Rated current	550 mA @ 24 V and 120 mA @ 110 V

Interfaces	
X1 – X12, Ethernet ports	9 × 10/100 Mbit/s, 3 × 10/100/1000 Mbit/s
USB	1 × USB 2.0, 480 Mbit/s
CON	1 × RS-232, 115.2 kbit/s

Temperature	
Operating	−40 to +70°C (−40 to +158°F)
Storage & Transport	−50 to +85°C (−58 to +185°F)

Agency approvals and standards compliance	
EMC	EN 61000-6-1, Immunity residential environments
	EN 61000-6-2, Immunity industrial environments
	EN 61000-6-3, Emission residential environments
	EN 61000-6-4, Emission industrial environments
	EN 50121-4/IEC 62236-4, Railway signaling and telecommunications apparatus
	EN 50121-3-2 Railway applications – Rolling stock – apparatus
Safety	IEC/EN 60950-1, IT equipment
Environmental	EN 50155 Railway applications – Electronic equipment used on rolling stock
	EN 61373 – Railway applications – Rolling stock equipment. Shock and vibration tests
	IEEE 1478 – Environmental conditions for transit rail car electronic equipment
	EN 50124-1 – Railway applications – Insulation coordination
	IEC 60068-2-27, (shock 100 g, 6 ms), IEC 60068-2-64
	CEN/TS 45545-2 – Fire protection