

NA2-N SERIES

New

General Purpose & Slim Body Area Sensor

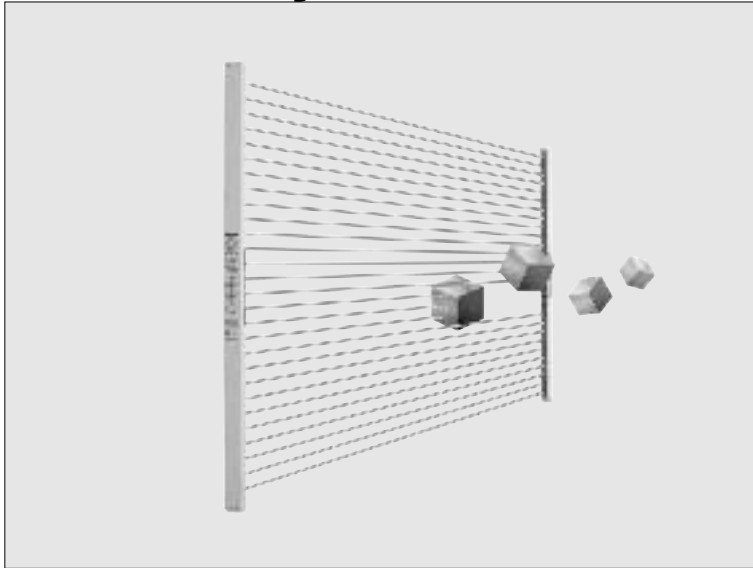

Slim body 13 mm (0.512 in)
Maximum sensing height 540 mm (21.260 in)



Maximum sensing height 540 mm 21.260 in (28 beam channels)

It realized the sensing height 540 mm 21.260 in (28 beam channels) in wide range of thin resin case type area sensor. With 20 mm 0.787 in beam pitch (minimum sensing object ϕ 30 mm ϕ 1.181 in) and sensing range 5 m 16.404 ft, it can meet various needs.

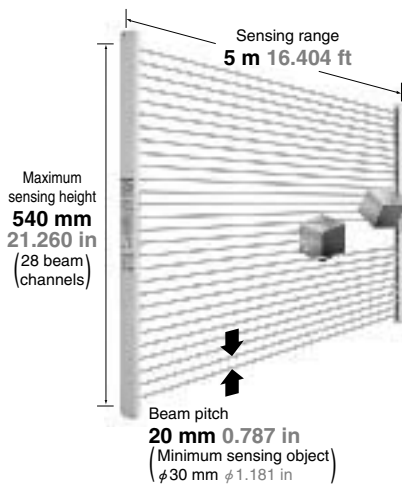

Slim body, just 13 mm 0.512 in thick

The slim body **NA2-N** series aesthetically fits in your equipment, since it is just 13 mm 0.512 in thick and 30 mm 1.181 in wide. It never disturbs your access to the machine.

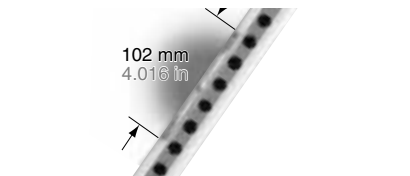

Clearly visible wide job indicator

Both the receiver and the emitter feature job indicators, 102 mm 4.016 in wide, which use red bright LEDs. When the sensing output and the job indicator input are connected, the job indicator can be used as a large size operation indicator.

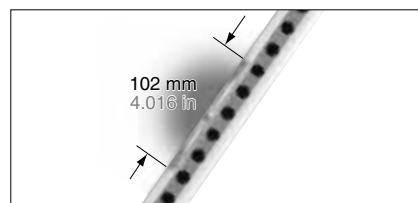

Sensing height 6 types

In addition to the conventional 12, 16, and 20 beam channel types, this new lineup includes 8, 24, and 28 beam channel types. A wide model variation is provided with detection height from 540 mm 21.260 in (28 beam channels) to 140 mm 5.512 in (8 beam channels).

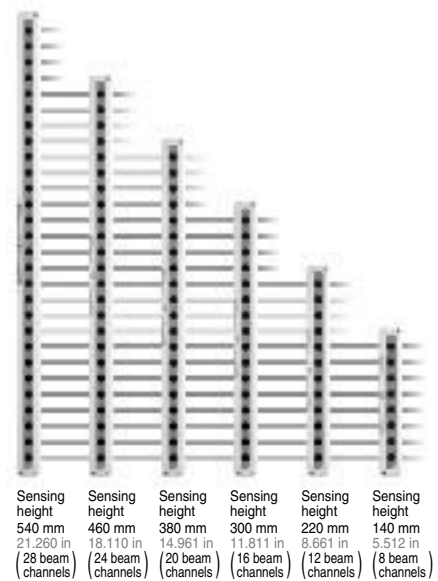

NA2-N

APPLICATIONS

Detecting falling objects whose path is uncertain

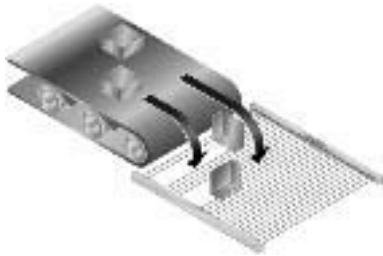

Detecting a loop

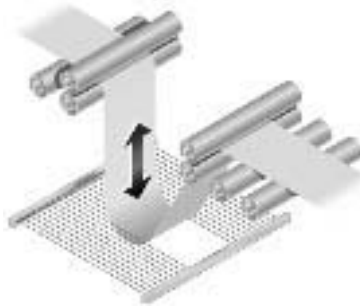

Preventing wrong parts picking



WARNING Never use this product in any personnel safety application.

Interference prevention for parallel installation

Setting different emission frequencies for two sensors prevents mutual interference. Use of two sensors together covers a wider detection area. The set frequencies can be identified by the number of emitting indicators which light up.

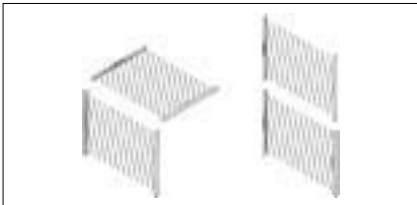

Convenient test input (emission halt) function

Beam output can be stopped via the input of an external signal. This is a useful test input (emission halt) function when beginning operation.

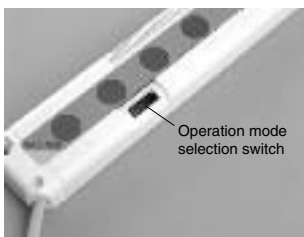
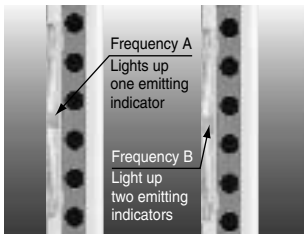

Selectable lighting pattern

The operation of the job indicator can be selected using the operation mode selection switch.

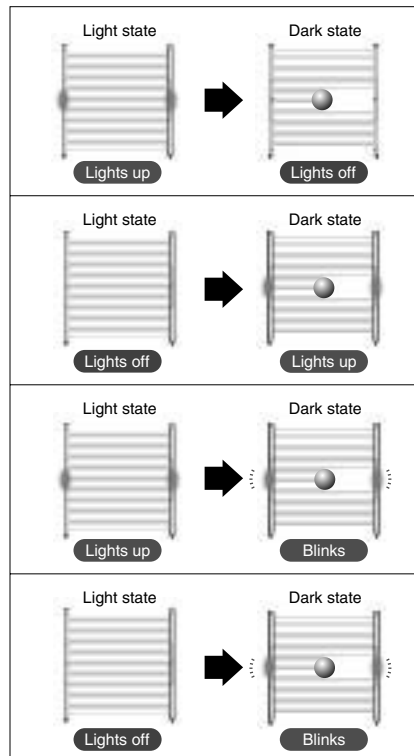

Globally useable

It conforms to the EMC Directive and obtains UL Recognition. Moreover, PNP output type which is much demand in Europe, is also available.

Receiver

Emitter

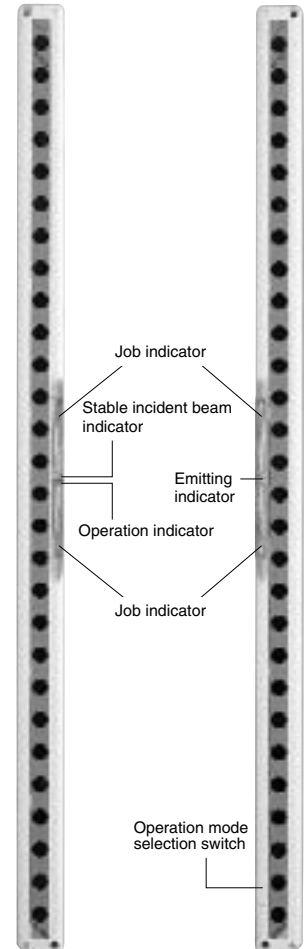

NA2-N

ORDER GUIDE

Type	Appearance	Sensing range	Model No.	Number of beam channels	Sensing height (mm in)	Output
NPN output type		5 m 16.404 ft	NA2-N8	8	140 5.512	NPN open-collector transistor
			NA2-N12	12	220 8.661	
			NA2-N16	16	300 11.811	
			NA2-N20	20	380 14.961	
			NA2-N24	24	460 18.110	
PNP output type			NA2-N28	28	540 21.260	PNP open-collector transistor
			NA2-N8-PN	8	140 5.512	
			NA2-N12-PN	12	220 8.661	
			NA2-N16-PN	16	300 11.811	
			NA2-N20-PN	20	380 14.961	
			NA2-N24-PN	24	460 18.110	
			NA2-N28-PN	28	540 21.260	

5 m 16.404 ft cable length type

5 m 16.404 ft cable length type is available (Standard: 3 m 9.843 ft)

• Table of Model Nos.

Type	Standard type	5 m 16.404 ft cable length type
NPN output type	NA2-N8	NA2-N8-C5
	NA2-N12	NA2-N12-C5
	NA2-N16	NA2-N16-C5
	NA2-N20	NA2-N20-C5
	NA2-N24	NA2-N24-C5
	NA2-N28	NA2-N28-C5

OPTIONS

Designation	Model No.	Description
Slit mask	OS-NA2-N8	For 8 beam channels
	OS-NA2-N12	For 12 beam channels
	OS-NA2-N16	For 16 beam channels
	OS-NA2-N20	For 20 beam channels
	OS-NA2-N24	For 24 beam channels
	OS-NA2-N28	For 28 beam channels
Sensor mounting bracket (Note)	MS-NA1-1	Four bracket set Eight M4 (length 18 mm 0.709 in) screws with washers (Four screws with washers are used), eight nuts, four hooks, four spacers and four M4 (length 15 mm 0.591 in) screws with washers are attached.
	MS-NA2-1	Spacers are not attached with MS-NA1-1. M4 (length 15 mm 0.591 in) screws with washers are not used for NA2-N series.
Sensor supporting bracket	MS-NA3-N8	For 8 beam channels
	MS-NA3-N12	For 12 beam channels
	MS-NA3-N16	For 16 beam channels
	MS-NA3-N20	For 20 beam channels
	MS-NA3-N24	For 24 beam channels
	MS-NA3-N28	For 28 beam channels

Note: Do not fix the sensor mounting bracket on the front surface of the sensor.

Slit mask

• OS-NA2-N□

The slit mask restricts the amount of beam emitted or received and is used to reduce interference between neighboring sensors. It is also used in cases when the beam intensity is too strong penetrating through the sensing object. Remove the cover (name plate) from the front of the sensor and replace it with the slit mask. The sensing range is reduced when the slit mask is used.

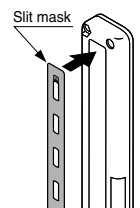

Sensor mounting bracket

• MS-NA1-1

• MS-NA2-1

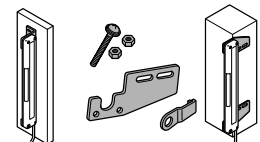
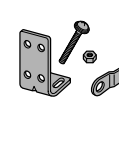

M4 screws with washers, nuts, and hooks are attached.

M4 screws with washers, nuts, hooks and spacers are attached.

Sensor supporting bracket

• MS-NA3-N□

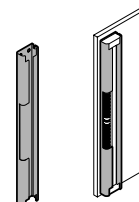

NA2-N

SPECIFICATIONS

Item	Number of beam channels		8	12	16	20	24	28
	Model No.	NPN output	NA2-N8	NA2-N12	NA2-N16	NA2-N20	NA2-N24	NA2-N28
		PNP output	NA2-N8-PN	NA2-N12-PN	NA2-N16-PN	NA2-N20-PN	NA2-N24-PN	NA2-N28-PN
Sensing height			140 mm 5.512 in	220 mm 8.661 in	300 mm 11.811 in	380 mm 14.961 in	460 mm 18.110 in	540 mm 21.260 in
Sensing range			5 m 16.404 ft					
Beam pitch			20 mm 0.787 in					
Sensing object			φ 30 mm φ 1.181 in or more opaque object					
Supply voltage			12 to 24 V DC ± 10 % Ripple P-P 10 % or less					
Power consumption (Note)	Emitter	Job indicator ON	0.7 W or less	0.8 W or less	0.9 W or less	1.0 W or less	1.1 W or less	1.2 W or less
		Job indicator OFF	0.6 W or less	0.7 W or less	0.8 W or less	0.9 W or less	1.0 W or less	1.1 W or less
	Receiver	Job indicator ON	0.7 W or less	0.8 W or less	0.9 W or less	1.0 W or less	1.1 W or less	1.2 W or less
		Job indicator OFF	0.6 W or less	0.7 W or less	0.8 W or less	0.9 W or less	1.0 W or less	1.1 W or less
Output			<NPN output type> NPN open-collector transistor <ul style="list-style-type: none"> • Maximum sink current: 100 mA • Applied voltage: 30 V DC or less (between output and 0 V) • Residual voltage: 1 V or less (at 100 mA sink current) 0.4 V or less (at 16 mA sink current) 			<PNP output type> PNP open-collector transistor <ul style="list-style-type: none"> • Maximum source current: 100 mA • Applied voltage: 30 V DC or less (between output and + V) • Residual voltage: 1 V or less (at 100 mA source current) 0.4 V or less (at 16 mA source current) 		
Utilization category			DC-12 or DC-13					
Output operation			ON when all beam channels are received (OFF when one or more beam channels are interrupted)					
Short-circuit protection			Incorporated					
Response time			10 ms or less (12 ms or less when the interference prevention function is used)					
Indicators	Emitter		Emitting indicator: Green LED × 2 (light up during emission; one LED lights up for Frequency A setting, both LEDs light up for Frequency B setting) Job indicator: Red LED (lights up, blinks or lights off when the job indicator input is applied, selected by operation mode switch)					
	Receiver		Operation indicator: Red LED (lights up when one or more beam channels are interrupted) Stable incident beam indicator: Green LED (lights up when all beam channels are stably received) Job indicator: Red LED (lights up, blinks or lights off when the job indicator input is applied, selected by operation mode switch) ※When an excess current flows through the output, the stable incident beam indicator and the operation indicator on the receiver blink simultaneously due to operation of the short-circuit protection circuit.					
Interference prevention function			Incorporated					
Test input (emission halt) function			Incorporated					
Environmental resistance	Pollution degree		3 (Industrial environment)					
	Ambient temperature		- 10 to + 55 °C + 14 to + 131 °F (No dew condensation or icing allowed), Storage: - 10 to + 60 °C + 14 to + 140 °F					
	Ambient humidity		35 to 85 % RH, Storage: 35 to 85 % RH					
	Ambient illuminance		Sunlight: 10,000 lx at the light-receiving face, Incandescent light: 3,000 lx at the light-receiving face					
	EMC		EN 50081-2, EN 50082-2, EN 60947-5-2					
	Voltage withstandability		1,000 V AC for one min. between all supply terminals connected together and enclosure					
	Insulation resistance		20 MΩ, or more, with 250 V DC megger between all supply terminals connected together and enclosure					
	Vibration resistance		10 to 150 Hz frequency, 0.75 mm 0.030 in amplitude in X, Y and Z directions for two hours each					
Shock resistance		500 m/s ² acceleration (50 G approx.) in X, Y and Z directions for three times each						
Emitting element			Infrared LED (modulated)					
Material			Enclosure: Heat-resistant ABS, Lens cover: Polyester, Indicator cover: Acrylic					
Cable			0.2 mm ² 4-core cabtyre cable, 3 m 9.843 ft long					
Cable extension			Extension up to total 25 m 82.021 ft is possible for both emitter and receiver, with 0.2 m ² , or more, cable.					
Weight (Total weight of emitter and receiver)			350 g approx.	400 g approx.	450 g approx.	500 g approx.	570 g approx.	650 g approx.

Note: Obtain the current consumption from the following equation.

Current consumption = Power consumption ÷ Supply voltage
(e.g.) In case of **NA2-N8** (when job indicator lights up)

When the supply voltage is 12 V, the current consumption of the emitter is: 0.7 W ÷ 12 V = 0.058 A = 58 mA.

NA2-N

I/O CIRCUIT AND WIRING DIAGRAMS

NPN output type

I/O circuit diagram

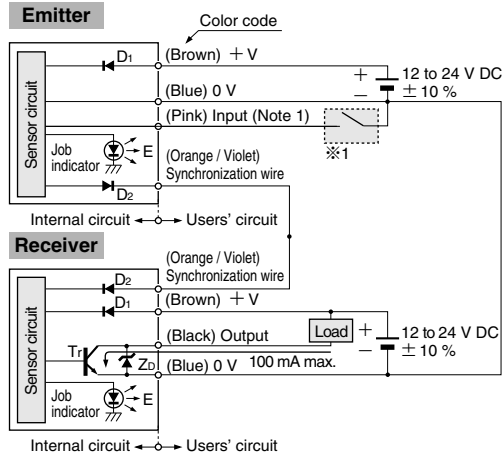

- Notes: 1) Input (pink) is the job indicator input when No. 4 of the operation mode switch on the emitter is set to the OFF side, and it is the test input (emission halt input) when the switch is set to the ON side.
- 2) In order to use the job indicator as a large operation indicator, connect the input (pink) of the emitter to the output (black) of the receiver.
- 3) When the test input (emission halt input) is set, the job indicator does not light up or blink.

Symbols ... D1: Reverse supply polarity protection diode
 D2: Reverse current protection diode
 Zb: Surge absorption zener diode
 Tr: NPN output transistor
 E: Job indicator

Wiring diagram

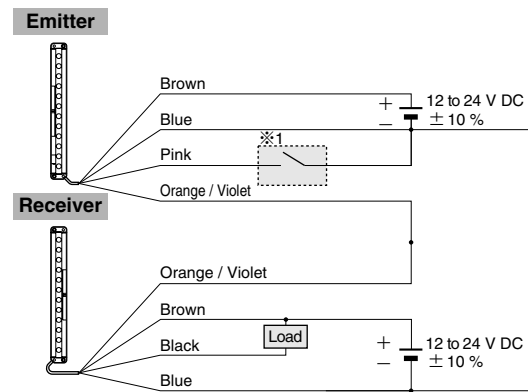

※1

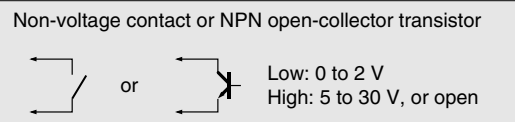

Note: Refer to **PRECAUTIONS FOR PROPER USE** on p.449~ for job indicator operation or test input (emission halt input) operation.

PNP output type

I/O circuit diagram

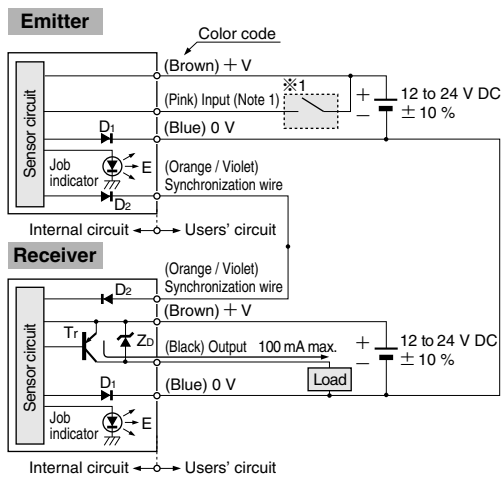

- Notes: 1) Input (pink) is the job indicator input when No. 4 of the operation mode switch on the emitter is set to the OFF side, and it is the test input (emission halt input) when the switch is set to the ON side.
- 2) In order to use the job indicator as a large operation indicator, connect the input (pink) of the emitter to the output (black) of the receiver.
- 3) When the test input (emission halt input) is set, the job indicator does not light up or blink.

Symbols ... D1: Reverse supply polarity protection diode
 D2: Reverse current protection diode
 Zb: Surge absorption zener diode
 Tr: PNP output transistor
 E: Job indicator

Wiring diagram

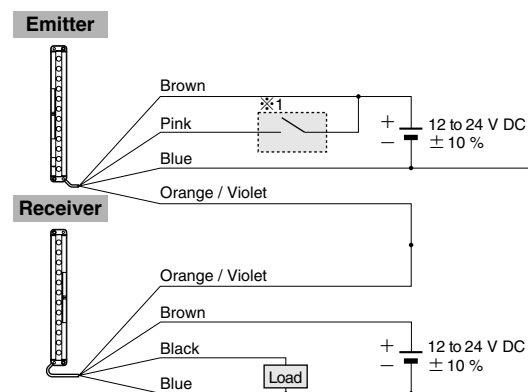

※1

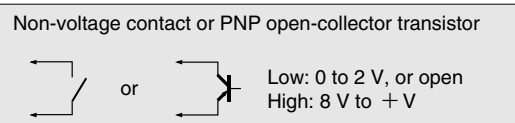

Note: Refer to **PRECAUTIONS FOR PROPER USE** on p.449~ for job indicator operation or test input (emission halt input) operation.

NA2-N

SENSING CHARACTERISTICS (TYPICAL)

Correlation between setting distance and excess gain

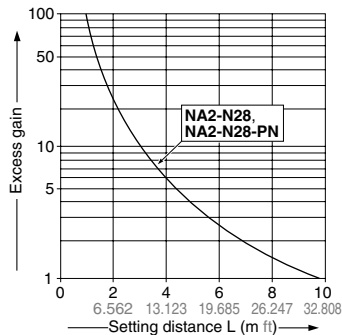

Parallel deviation (All models)

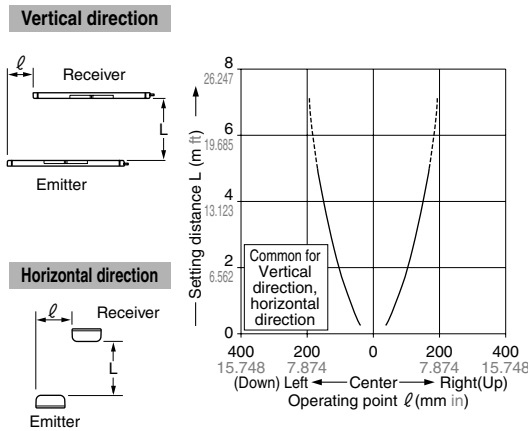

Angular deviation (All models)

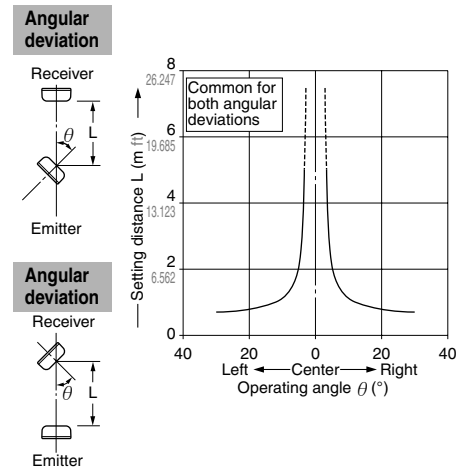

PRECAUTIONS FOR PROPER USE



- Never use this product as a sensing device for personnel protection.
- For sensing devices to be used as safety devices for press machines or for personnel protection, use products which meet standards, such as OSHA, ANSI or IEC etc., for personnel protection applicable in each region or country.
- If this product is used as a sensing device for personnel protection, death or serious body injury could result.
- For a product which meets safety standards, use the following products.
 Type 4: **SF4-AH** series
SF2-EH series
 Type 2: **SF2-A** series
SF2-N series

Mounting

- Use M4 screws with washers and M4 nuts. The tightening torque should be 0.5 N·m or less. During mounting, do not apply any bending or twisting force to the sensor.
 (Please arrange the screws and nuts) separately.

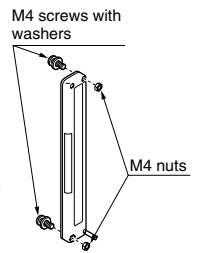

Functional description

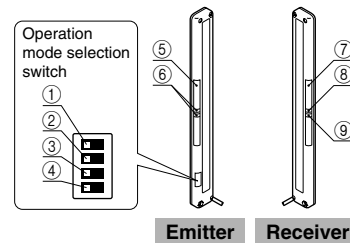

Job indicator operation selection

- The operation of the job indicator can be selected with job indicator mode switch.

Job indicator mode switch	Job indicator operation	
	Job indicator input: Low	Job indicator input: High
1 2 3 4	Lights up	Lights off
1 2 3 4	Lights off	Lights up
1 2 3 4	Lights up	Blinks
1 2 3 4	Lights off	Blinks

Job indicator input signal condition

Output	Signal	Signal condition
NPN output	Low	0 to 2 V
	High	5 to 30 V, or open (Note)
PNP output	Low	0 to 2 V, or open (Note)
	High	8 V to + V

Note: Insulate the wire if it is kept open.

	Description	Function	
Emitter	① Emission frequency selection switch	1 <input type="checkbox"/> : Frequency A 1 <input type="checkbox"/> : Frequency B	
	② Job indicator mode switch	2 <input type="checkbox"/> : Lights up when the job indicator input is Low	2 <input type="checkbox"/> : Lights off when the job indicator input is Low
		3 <input type="checkbox"/> : Lighting	3 <input type="checkbox"/> : Blinking
	④ Job indicator / Test input (emission halt input) selection switch	4 <input type="checkbox"/> : Job indicator input 4 <input type="checkbox"/> : Test input (emission halt input)	
	⑤ Job indicator (Red LED)	Lights up, blinks or lights off when the job indicator input is applied, selected by operation mode switch.	
	⑥ Emitting indicator (Green LED × 2)	Light up during emission; one LED lights up for Frequency A setting, both LEDs light up for Frequency B setting.	
Receiver	⑦ Job indicator (Red LED)	Lights up, blinks or lights off when the job indicator input is applied, selected by operation mode switch.	
	⑧ Stable incident beam indicator (Green LED)	Lights up when all beam channels are stably received. When an excess current flows through the output, the stable incident beam indicator and the operation indicator on the receiver blink simultaneously due to the operation of the short-circuit protection circuit.	
	⑨ Operation indicator (Red LED)	Lights up when one or more beam channels are interrupted.	

NA2-N

PRECAUTIONS FOR PROPER USE

To use job indicator as large operation indicator

- The job indicators can be used as large operation indicators by setting No. 4 of the operation mode switch to the OFF side and connecting the input (pink) of the emitter to the output (black) of the receiver.

Job indicator mode switch	Light state	Dark state
	Lights up	Lights off
	Lights off	Lights up
	Lights up	Blinks
	Lights off	Blinks

Note: In order to use the job indicators as large operation indicators, make sure to set No. 4 of the operation mode switch to the OFF side. If it is set to the ON side, the job indicator does not light up or blink.

Orientation

- The emitter and the receiver must face each other correctly. If they are set upside down, the sensor does not work.

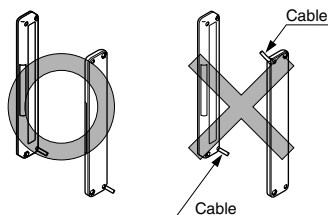

Test input (emission halt) function

- The emission is stopped when No. 4 of the operation mode switch is set to the ON side and the input (pink) of the emitter is made High (PNP output type: Low). Since the output can be turned ON / OFF without the sensing object, this function is useful for start-up inspection. If the output follows the application / withdrawal of the test input (emission halt input), the sensor operation is normal, else it is abnormal.

Operation mode switch setting

OFF	ON

Time chart

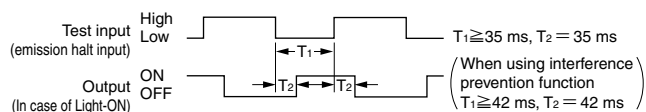

- Notes: 1) When the test input (emission halt) function is set, the job indicator (red) does not light up or blink.
 2) When emission is stopped during the test input (emission halt) function, the emitter's emitting indicator (green) does not light up.

Interference prevention function

- By setting different emission frequencies, two units of NA2-N series can be mounted close together, as shown in the figure below. The emission frequency can be checked by the number of LEDs lighting up in the emitting indicator on the emitter.

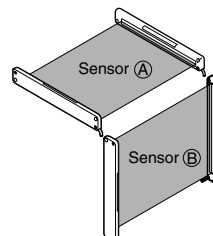

	Operation mode switch	Emitting indicator (Emitter)
Sensor A	Frequency A	One LED lights up
Sensor B	Frequency B	Two LEDs light up

Wiring

- Make sure that the power supply is off while wiring.
- Verify that the supply voltage variation is within the rating.
- If power is supplied from a commercial switching regulator, ensure that the frame ground (F.G.) terminal of the power supply is connected to an actual ground.
- In case noise generating equipment (switching regulator, inverter motor, etc.) is used in the vicinity of this sensor, connect the frame ground. (F.G.) terminal of the equipment to an actual ground.
- Do not run the wires together with high-voltage lines or power lines or put them in the same raceway. This can cause malfunction due to induction.

Others

- Do not use during the initial transient time (500 ms) after the power supply is switched on.
- Avoid dust, dirt and steam.
- Take care that the sensor does not come in direct contact with water, oil, grease, or organic solvents, such as, thinner, etc.
- Take care that the sensor is not directly exposed to fluorescent light from a rapid-starter lamp or a high frequency lighting device, as it may affect the sensing performance.

NA2-N

DIMENSIONS (Unit: mm in)

NA2-N / NA2-N(-PN) Sensor

Emitter

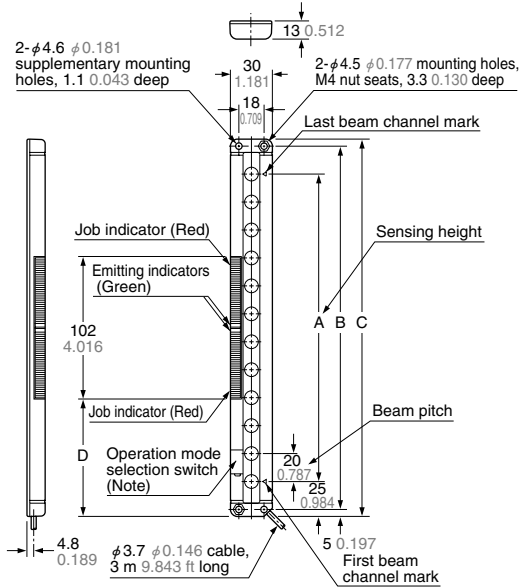

Note: Located on the right side in case of NA2-N8(-PN).

Receiver

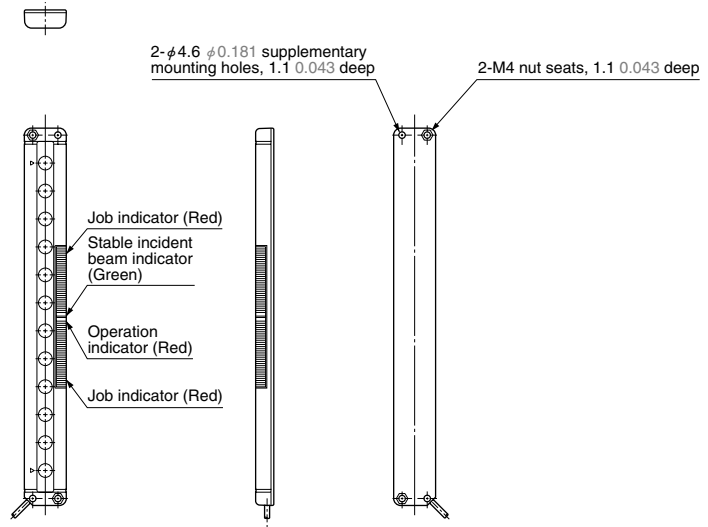

Model No.	A	B	C	D
NA2-N8(-PN)	140 5.512	180 7.087	190 7.480	52 2.047
NA2-N12(-PN)	220 8.661	260 10.236	270 10.630	84 3.307
NA2-N16(-PN)	300 11.811	340 13.386	350 13.780	124 4.882
NA2-N20(-PN)	380 14.961	420 16.535	430 16.929	164 6.457
NA2-N24(-PN)	460 18.110	500 19.685	510 20.079	204 8.031
NA2-N28(-PN)	540 21.260	580 22.835	590 23.228	244 9.606

MS-NA1-1 Sensor mounting bracket (Optional)

Assembly dimensions

Mounting drawing with the receiver

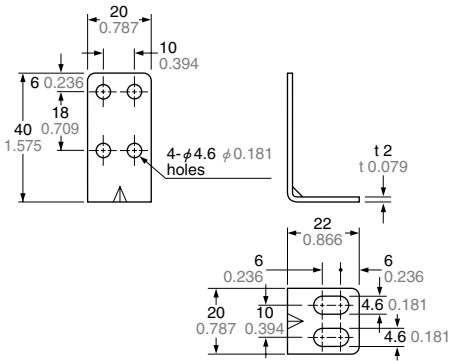

Material: Cold rolled carbon steel (SPCC)
(Uni-chrome plated)

Four bracket set

- Eight M4 (length 18 mm 0.709 in) screws with washers (Four screws with washers are used), eight nuts, four hooks, and four M4 (length 15 mm 0.591 in) screws with washers are attached.
- M4 (length 15 mm 0.591 in) screws with washers are not used for NA2-N series.

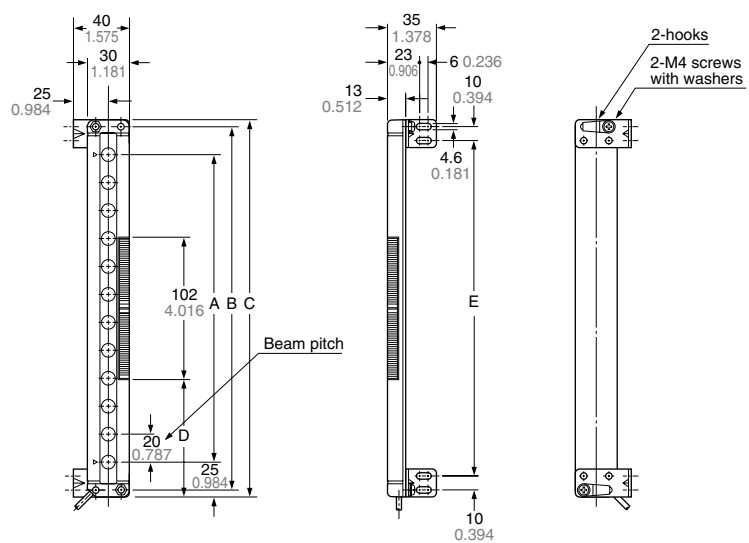

Model No.	A	B	C	D	E
NA2-N8(-PN)	140 5.512	180 7.087	190 7.480	52 2.047	160 6.299
NA2-N12(-PN)	220 8.661	260 10.236	270 10.630	84 3.307	240 9.449
NA2-N16(-PN)	300 11.811	340 13.386	350 13.780	124 4.882	320 12.598
NA2-N20(-PN)	380 14.961	420 16.535	430 16.929	164 6.457	400 15.748
NA2-N24(-PN)	460 18.110	500 19.685	510 20.079	204 8.031	480 18.898
NA2-N28(-PN)	540 21.260	580 22.835	590 23.228	244 9.606	560 22.047

NA2-N

DIMENSIONS (Unit: mm in)

MS-NA2-1 Sensor mounting bracket (Optional)

Assembly dimensions Mounting drawing with the receiver

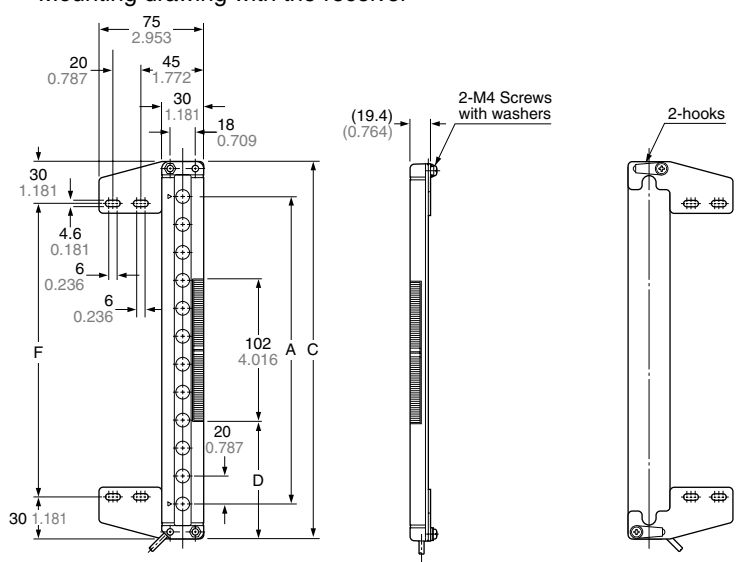
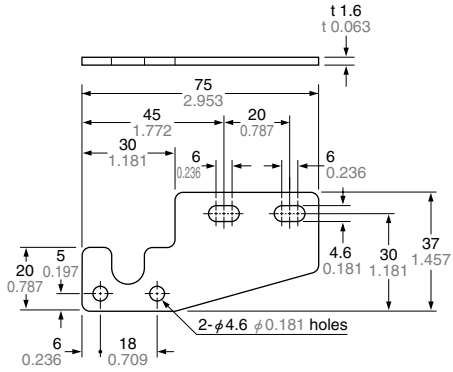

Material: Cold rolled carbon steel (SPCC)
(Uni-chrome plated)

Four bracket set
Eight M4 (length 18 mm 0.709 in) screws with washers
(Four screws with washers are used,
eight nuts, four hooks, four spacers and four M4 (length
15 mm 0.591 in) screws with washers are attached.
M4 (length 15 mm 0.591 in) screws with washers are not
used for NA2-N series.

Model No.	A	C	D	F
NA2-N8(-PN)	140 5.512	190 7.480	52 2.047	130 5.118
NA2-N12(-PN)	220 8.661	270 10.630	84 3.307	210 8.268
NA2-N16(-PN)	300 11.811	350 13.780	124 4.882	290 11.417
NA2-N20(-PN)	380 14.961	430 16.929	164 6.457	370 14.567
NA2-N24(-PN)	460 18.110	510 20.079	204 8.031	450 17.717
NA2-N28(-PN)	540 21.260	590 23.228	244 9.606	530 20.866

MS-NA3-N Sensor supporting bracket (Optional)

Assembly dimensions Mounting drawing with the receiver

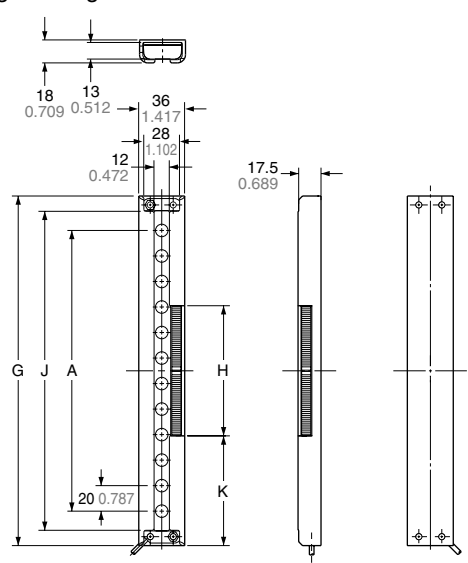
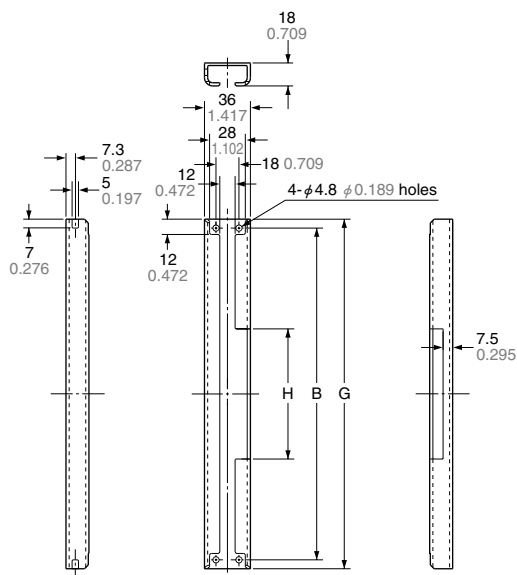

Note: The sensor supporting bracket can be used for both the emitter and the receiver.

Material: Aluminum (Black ALMITE)
Two bracket set

Model No.	A	B	G	H	J	K
MS-NA3-N8	140 5.512	180 7.087	194 7.638	118 4.646	170 6.693	38 1.496
MS-NA3-N12	220 8.661	260 10.236	274 10.787	102 4.016	250 9.843	86 3.386
MS-NA3-N16	300 11.811	340 13.386	354 13.937	102 4.016	330 12.992	126 4.961
MS-NA3-N20	380 14.961	420 16.535	434 17.087	102 4.016	410 16.142	166 6.535
MS-NA3-N24	460 18.110	500 19.685	514 20.236	102 4.016	490 19.291	206 8.110
MS-NA3-N28	540 21.260	580 22.835	594 23.386	102 4.016	570 22.441	246 9.685