

# SinCos<sup>®</sup> SEK/SEL52 and SEK/SEL37: Motor Feedback Systems with HIPERFACE<sup>®</sup> interface

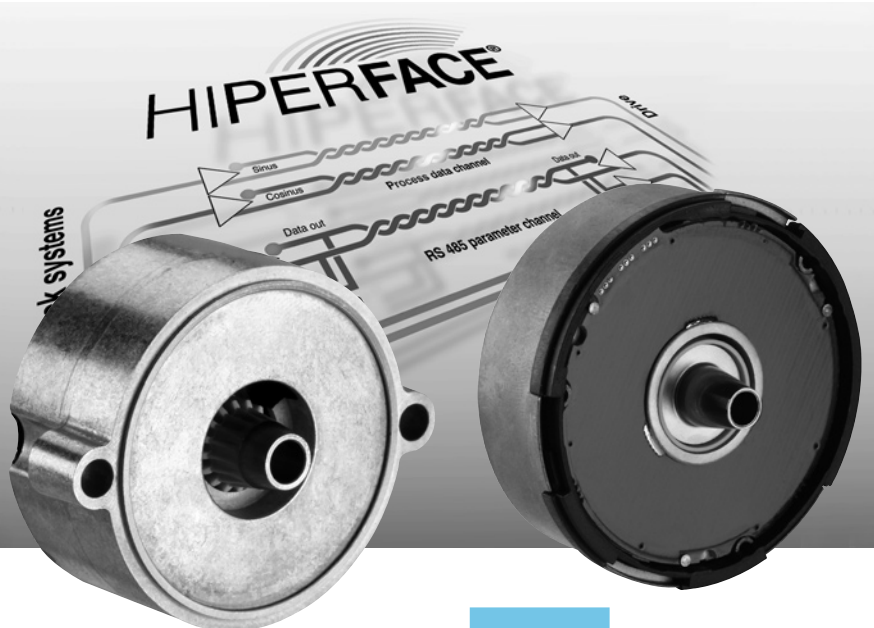

The holistic scanning almost completely compensates for eccentricity errors. The capacitive operating principle can function without ball bearings and is therefore extremely robust. By dispensing with wearing parts, possible error sources are largely excluded, and the motor feedback systems have a high temperature resistance previously reserved for resolvers. Moreover, the system construction allows extremely low power consumption.

The compact SEK/SEL37 products are designed for mounting onto conical shafts. In addition to the shoulder clamping used with resolvers, SEK/SEL device types in the 2.1" housing also feature hollow shaft and conical shaft types. Thus, these motor feedback systems with high resolution are particularly suited to industrial applications requiring a compact, precise and cost-effective solution.

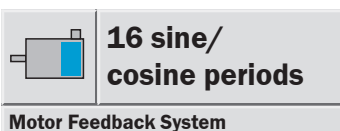

**HIPERFACE<sup>®</sup>**  
by **SICK | STEGMANN**



**E**xtreme robustness, multiturn capability and all benefits of the HIPERFACE<sup>®</sup> interface are reflected in the new SinCos<sup>®</sup> SEK/SEL52 and SEK/SEL37 product ranges.

At the heart of these new ranges is a bearing-less, capacitive sensor element.

**SICK | STEGMANN**

**16 sine/cosine periods**

Motor Feedback System

- 16 sine/cosine periods per revolution
- 4,096 revolutions measurable (Multiturn)
- Programming of the positional value
- Electronic type label



## Dimensional drawing SEK/SEL52 tapered shaft

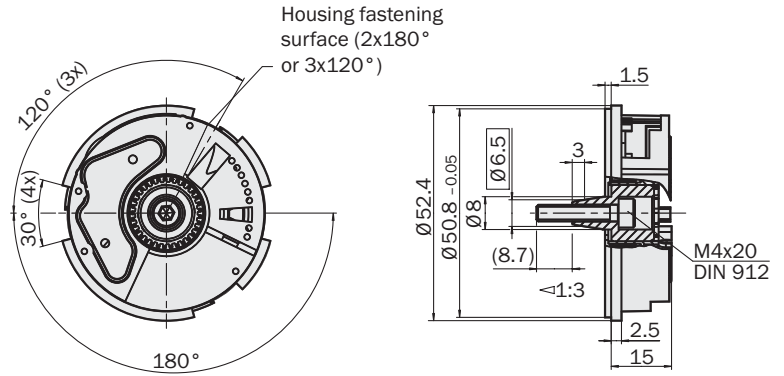

## Proposed customer fitting

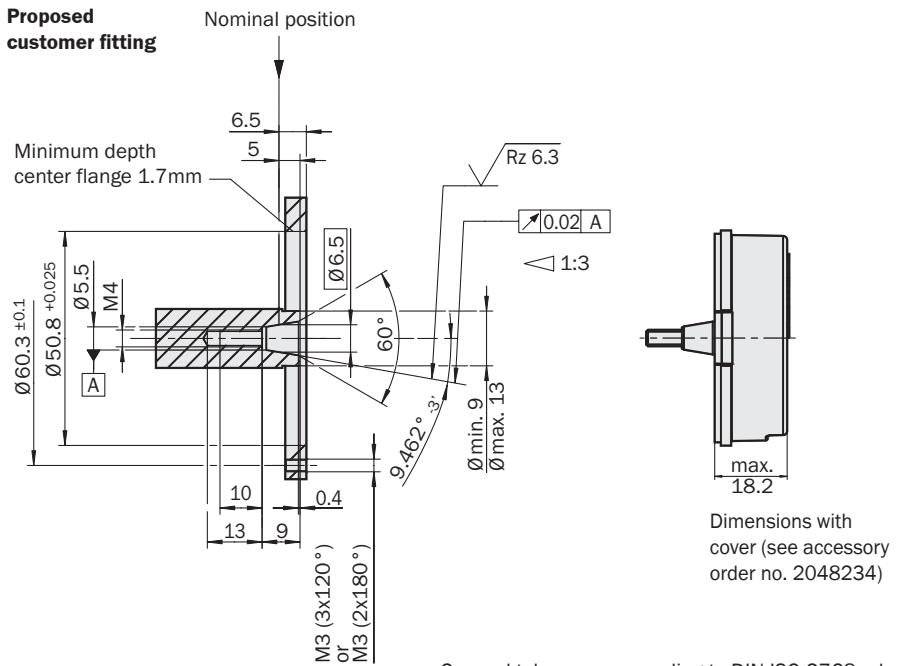

General tolerances according to DIN ISO 2768-mk

## Pin and wire allocation

PIN	Signal	Colour of wires	Explanation
1	U <sub>s</sub>	red	Supply voltage 7 ... 12 V
2	+ SIN	white	Process data channel
3	REFSIN	brown	Process data channel
4	+ COS	pink	Process data channel
5	REFCOS	black	Process data channel
6	GND	blue	Ground connection
7	Data +	grey or yellow	RS485-parameter channel
8	Data -	green or purple	RS485-parameter channel

The GND-(0V) connection of the supply voltage has no connection to the housing.

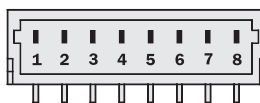

Accessories
Connection systems
Mounting systems
Programming Tool
Cover

Technical Data to DIN 32878		Tapered shaft SEK/SEL52	SEK	SEL								
<b>Number of sine/cosine periods per revolution</b>		16										
<b>Number of the absolute ascertainable revolutions</b>	Single SEK	1										
	Multi SEL	4,096										
<b>Dimensions</b>		mm (see dimensional drawing)										
<b>Mass</b>		0.04 kg										
<b>Mass with cover <sup>1)</sup></b>		0.07 kg										
<b>Moment of inertia to the rotor</b>		7 gcm <sup>2</sup>										
<b>Code type for the absolute value</b>		Binary										
<b>Code sequence for clockwise shaft rotation, looking in direction "A" (see dimensional drawing)</b>		Increasing										
<b>Measurement step at interpolation of the sine/cosine signals with e. g. 12 bits</b>		20 angular seconds										
<b>Error limits for evaluating the sine/cosine signals</b>												
integral non-linearity		± 288 angular seconds										
<b>Non-linearity within a sine/cosine period</b>												
differential non-linearity		± 72 angular seconds <sup>2)</sup>										
<b>Working speed up to which the absolute position can be reliably produced</b>		6,000 min <sup>-1</sup>										
<b>Max. Operating speed</b>	Single SEK	12,000 min <sup>-1</sup>										
	Multi SEL	10,000 min <sup>-1</sup>										
<b>Max. angular acceleration</b>		5 x 10 <sup>5</sup> rad/s <sup>2</sup>										
<b>Permissible shaft movement</b>												
axial		± 0.5 mm										
radial		± 0.15 mm										
<b>Working temperature range</b>	Single SEK	- 40 ... + 115 °C										
	Multi SEL	- 20 ... + 115 °C										
<b>Storage temperature range <sup>3)</sup></b>		- 50 ... + 125 °C										
<b>Permissible relative humidity</b>		90 % <sup>4)</sup>										
<b>Resistance</b>												
To shocks <sup>5)</sup>		100 g/10 ms										
To vibration <sup>6)</sup>		50 g/10 ... 2000 Hz										
<b>Protection class to IEC 60529 <sup>7)</sup></b>		IP 40										
<b>EMC <sup>8)</sup></b>												
<b>Operating voltage range</b>		7 ... 12 V										
<b>Recommended supply voltage</b>		8 V										
<b>Max. operating current, no load</b>		< 50 mA										
<b>Available memory area</b>												
within EEPROM 2048 <sup>9)</sup>		1,792 bytes										
<b>Interface signals</b>												
Process data channel = SIN, REFSIN, COS, REFCOS		Analogue, differential										
Parameter channel = RS 485		Digital										

<sup>1)</sup> Accessory part no. 2048234

<sup>2)</sup> At nominal position ± 0.1 mm

<sup>3)</sup> Without packaging

<sup>4)</sup> Condensation not permitted

<sup>5)</sup> To EN 60068-2-27

<sup>6)</sup> To EN 60068-2-6

<sup>7)</sup> With mating connector inserted and closed cover

<sup>8)</sup> To EN 61000-6-2 and EN 61000-6-3

The EMC according to the standards quoted is achieved when the motor feedback system is mounted in an electrically conductive housing, which is connected to the central earthing point of the motor controller via a cable screen and by using the cover (see accessory part no. 2048234).

Users must perform their own tests when other screen designs are used.

<sup>9)</sup> If applying the electronic type label, in connection with numeric controllers, attention should be paid to Patent EP 425 912 B 2; Application of the electronic type label in connection with speed regulation is exempt.

#### Ordering information

##### SEK/SEL52 tapered shaft

Type	Part no.	Description
SEK52-HFA0-K02	1037368	Single
SEL52-HFA0-K02	1037371	Multi

 **16 sine/cosine periods**

Motor Feedback System

- 16 sine/cosine periods per revolution
- 4,096 revolutions measurable (Multiturn)
- Programming of the positional value
- Electronic type label

**Dimensional drawing SEK/SEL52 hollow shaft**

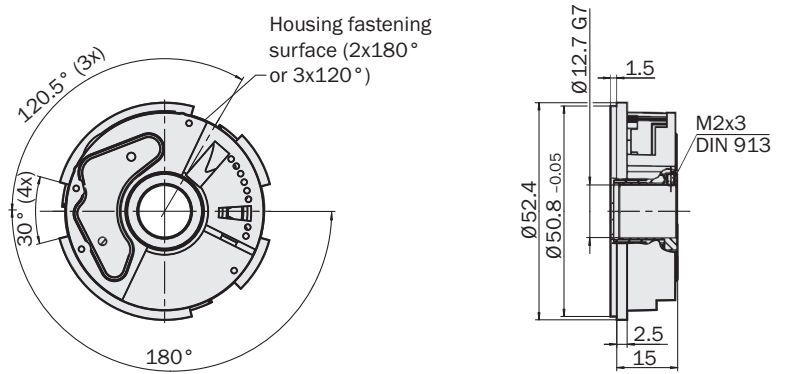

**Proposed customer fitting**

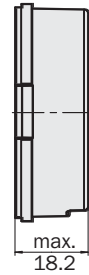
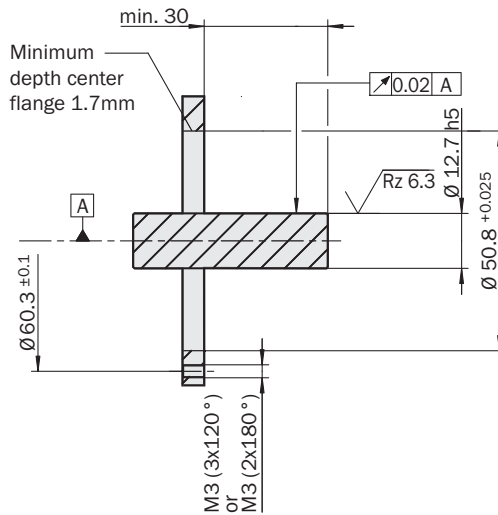

Dimensions with cover (see accessory order no. 2048232)

General tolerances according to DIN ISO 2768-mk

**Pin and wire allocation**

PIN	Signal	Colour of wires	Explanation
1	U <sub>s</sub>	red	Supply voltage 7 ... 12 V
2	+ SIN	white	Process data channel
3	REFSIN	brown	Process data channel
4	+ COS	pink	Process data channel
5	REFCOS	black	Process data channel
6	GND	blue	Ground connection
7	Data +	grey or yellow	RS485-parameter channel
8	Data -	green or purple	RS485-parameter channel

The GND-(0V) connection of the supply voltage has no connection to the housing.

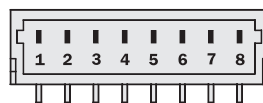

**Accessories**

Connection systems
Mounting systems
Programming Tool
Cover

Technical Data to DIN 32878		Hollow shaft SEK/SEL52	SEK	SEL								
<b>Number of sine/cosine periods per revolution</b>		16										
<b>Number of the absolute ascertainable revolutions</b>	Single SEK	1										
	Multi SEL	4,096										
<b>Dimensions</b>		mm (see dimensional drawing)										
<b>Mass</b>		0.04 kg										
<b>Mass with cover <sup>1)</sup></b>		0.06 kg										
<b>Moment of inertia to the rotor</b>		7 gcm <sup>2</sup>										
<b>Code type for the absolut value</b>		Binary										
<b>Code sequence for clockwise shaft rotation, looking in direction "A" (see dimensional drawing)</b>		Increasing										
<b>Measurement step at interpolation of the sine/cosine signals with e. g. 12 bits</b>		20 angular seconds										
<b>Error limits for evaluating the sine/cosine signals</b>												
integral non-linearity		± 288 angular seconds										
<b>Non-linearity within a sine/cosine period</b>												
differential non-linearity		± 72 angular seconds <sup>2)</sup>										
<b>Working speed up to which the absolute position can be reliably produced</b>		6,000 min <sup>-1</sup>										
<b>Max. Operating speed</b>	Single SEK	12,000 min <sup>-1</sup>										
	Multi SEL	10,000 min <sup>-1</sup>										
<b>Max. angular acceleration</b>		5 x 10 <sup>5</sup> rad/s <sup>2</sup>										
<b>Permissible shaft movement</b>												
axial		± 0.5 mm										
radial		± 0.15 mm										
<b>Working temperature range</b>	Single SEK	- 40 ... + 115 °C										
	Multi SEL	- 20 ... + 115 °C										
<b>Storage temperature range <sup>3)</sup></b>		- 50 ... + 125 °C										
<b>Permissible relative humidity</b>		90 % <sup>4)</sup>										
<b>Resistance</b>												
To shocks <sup>5)</sup>		100 g/10 ms										
To vibration <sup>6)</sup>		50 g/10 ... 2000 Hz										
<b>Protection class to IEC 60529 <sup>7)</sup></b>		IP 40										
<b>EMC <sup>8)</sup></b>												
<b>Operating voltage range</b>		7 ... 12 V										
<b>Recommended supply voltage</b>		8 V										
<b>Max. operating current, no load</b>		< 50 mA										
<b>Available memory area</b>												
within EEPROM 2048 <sup>9)</sup>		1,792 bytes										
<b>Interface signals</b>												
Process data channel = SIN, REFSIN, COS, REFCOS		Analogue, differential										
Parameter channel = RS 485		Digital										

<sup>1)</sup> Accessory part no. 2048232

<sup>2)</sup> At nominal position ± 0.1 mm

<sup>3)</sup> Without packaging

<sup>4)</sup> Condensation not permitted

<sup>5)</sup> To EN 60068-2-27

<sup>6)</sup> To EN 60068-2-6

<sup>7)</sup> With mating connector inserted and closed cover

<sup>8)</sup> To EN 61000-6-2 and EN 61000-6-3

The EMC according to the standards quoted is achieved when the motor feedback system is mounted in an electrically conductive housing, which is connected to the central earthing point of the motor controller via a cable screen and by using the cover (see accessory part no. 2048232).

Users must perform their own tests when other screen designs are used.

<sup>9)</sup> If applying the electronic type label, in connection with numeric controllers, attention should be paid to Patent EP 425 912 B 2; Application of the electronic type label in connection with speed regulation is exempt.

#### Ordering information

##### SEK/SEL52 hollow shaft

Type	Part no.	Description
SEK52-HNA0-K02	1037370	Single
SEL52-HNA0-K02	1037373	Multi

 **16 sine/cosine periods**

**Motor Feedback System**

- 16 sine/cosine periods per revolution
- 4,096 revolutions measurable (Multiturn)
- Programming of the positional value
- Electronic type label



**Dimensional drawing SEK/SEL52 with shoulder clamping**

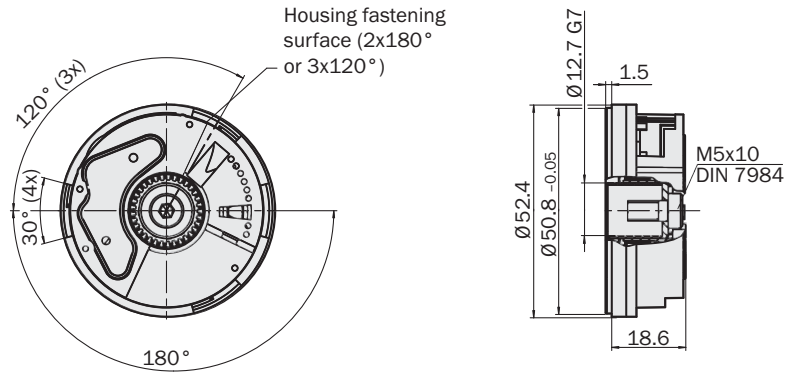

**Proposed customer fitting**

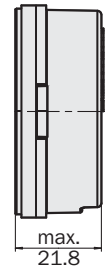
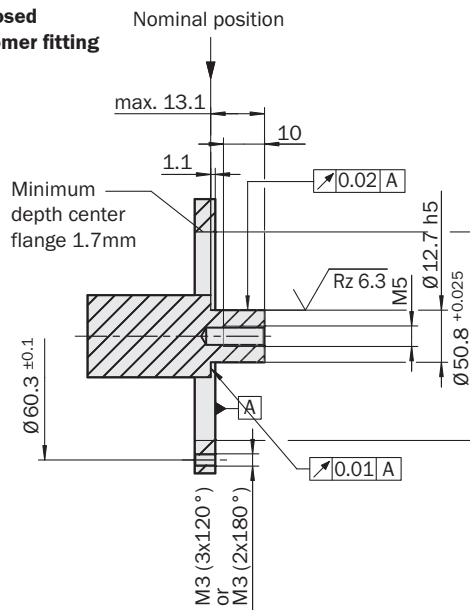

Dimensions with cover (see accessory order no. 2048234)

General tolerances according to DIN ISO 2768-mk

**Pin and wire allocation**

PIN	Signal	Colour of wires	Explanation
1	U <sub>s</sub>	red	Supply voltage 7 ... 12 V
2	+ SIN	white	Process data channel
3	REFSIN	brown	Process data channel
4	+ COS	pink	Process data channel
5	REFCOS	black	Process data channel
6	GND	blue	Ground connection
7	Data +	grey or yellow	RS485-parameter channel
8	Data -	green or purple	RS485-parameter channel

The GND-(0V) connection of the supply voltage has no connection to the housing.

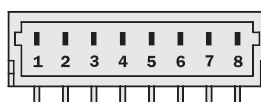

**Accessories**

Connection systems
Mounting systems
Programming Tool
Cover

Technische Daten nach DIN 32878		Shoulder clamping SEK/SEL52	SEK	SEL								
<b>Number of sine/cosine periods per revolution</b>	16											
<b>Number of the absolute ascertainable revolutions</b>	Single SEK	1										
	Multi SEL	4,096										
<b>Dimensions</b>		mm (see dimensional drawing)										
<b>Mass</b>		0.04 kg										
<b>Mass with cover <sup>1)</sup></b>		0.07 kg										
<b>Moment of inertia to the rotor</b>		6 gcm <sup>2</sup>										
<b>Code type for the absolute value</b>		Binary										
<b>Code sequence for clockwise shaft rotation, looking in direction "A" (see dimensional drawing)</b>		Increasing										
<b>Measurement step at interpolation of the sine/cosine signals with e. g. 12 bits</b>		20 angular seconds										
<b>Error limits for evaluating the sine/cosine signals</b>												
integral non-linearity		± 288 angular seconds										
<b>Non-linearity within a sine/cosine period</b>												
differential non-linearity		± 72 angular seconds <sup>2)</sup>										
<b>Working speed up to which the absolute position can be reliably produced</b>		6,000 min <sup>-1</sup>										
<b>Max. Operating speed</b>	Single SEK	12,000 min <sup>-1</sup>										
	Multi SEL	10,000 min <sup>-1</sup>										
<b>Max. angular acceleration</b>		5 x 10 <sup>5</sup> rad/s <sup>2</sup>										
<b>Permissible shaft movement</b>												
axial		± 0.5 mm										
radial		± 0.15 mm										
<b>Working temperature range</b>	Single SEK	- 40 ... + 115 °C										
	Multi SEL	- 20 ... + 115 °C										
<b>Storage temperature range <sup>3)</sup></b>		- 50 ... + 125 °C										
<b>Permissible relative humidity</b>		90 % <sup>4)</sup>										
<b>Resistance</b>												
To shocks <sup>3)</sup>		100 g/10 ms										
To vibration <sup>4)</sup>		50 g/10 ... 2000 Hz										
<b>Protection class to IEC 60529 <sup>5)</sup></b>		IP 40										
<b>EMC <sup>6)</sup></b>												
<b>Operating voltage range</b>		7 ... 12 V										
<b>Recommended supply voltage</b>		8 V										
<b>Max. operating current, no load</b>		< 50 mA										
<b>Available memory area</b>												
within EEPROM 2048 <sup>7)</sup>		1,792 bytes										
<b>Interface signals</b>												
Process data channel = SIN, REFSIN, COS, REFCOS		Analogue, differential										
Parameter channel = RS 485		Digital										

<sup>1)</sup> Accessory part no. 2048234

<sup>2)</sup> At nominal position ± 0.1 mm

<sup>3)</sup> Without packaging

<sup>4)</sup> Condensation not permitted

<sup>5)</sup> To EN 60068-2-27

<sup>6)</sup> To EN 60068-2-6

<sup>7)</sup> With mating connector inserted and closed cover

<sup>8)</sup> To EN 61000-6-2 and EN 61000-6-3

The EMC according to the standards quoted is achieved when the motor feedback system is mounted in an electrically conductive housing, which is connected to the central earthing point of the motor controller via a cable screen and by using the cover (see accessory part no. 2048234).

Users must perform their own tests when other screen designs are used.

<sup>9)</sup> If applying the electronic type label, in connection with numeric controllers, attention should be paid to Patent EP 425 912 B 2; Application of the electronic type label in connection with speed regulation is exempt.

#### Ordering information

##### SEK/SEL52 with shoulder clamping

Type	Part no.	Description
SEK52-H1A0-K02	1037369	Single
SEL52-H1A0-K02	1037372	Multi

**16 sine/cosine periods**

Motor Feedback System

- 16 sine/cosine periods per revolution
- 4,096 revolutions measurable (Multiturn)
- Programming of the positional value
- Electronic type label

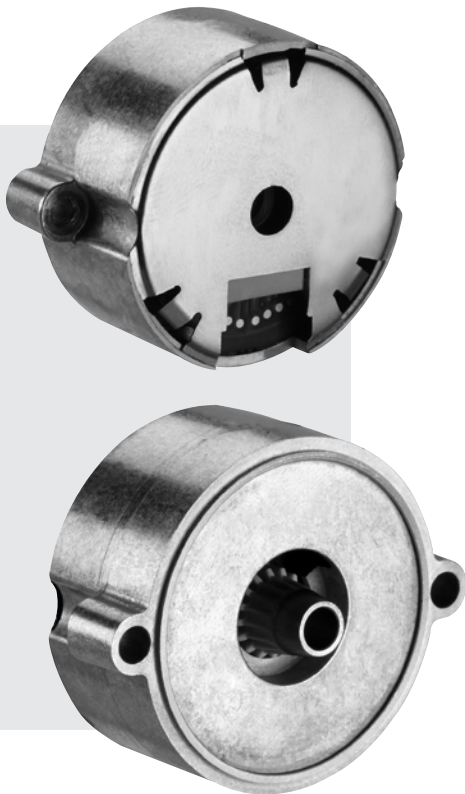

**Dimensional drawing SEK/SEL37 radial connector**

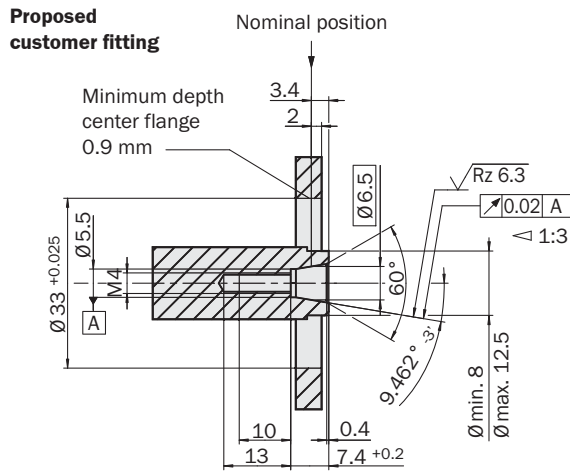
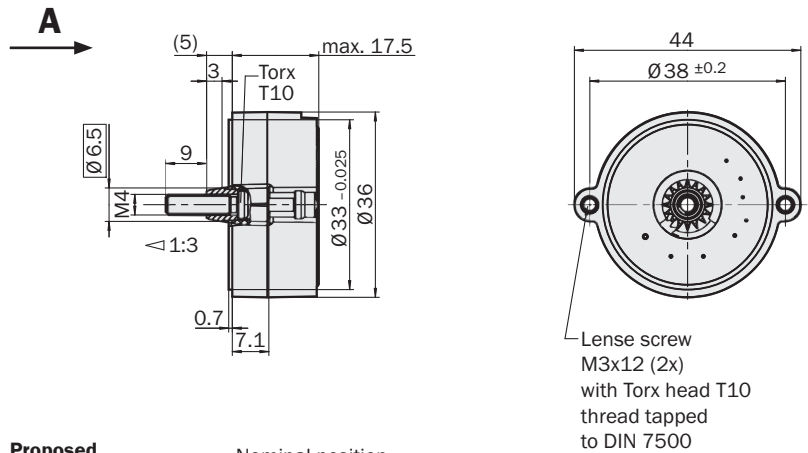

General tolerances according to DIN ISO 2768-mk

**Pin and wire allocation**

PIN	Signal	Colour of wires	Explanation
1	U <sub>s</sub>	red	Supply voltage 7 ... 12 V
2	+ SIN	white	Process data channel
3	REFSIN	brown	Process data channel
4	+ COS	pink	Process data channel
5	REFCOS	black	Process data channel
6	GND	blue	Ground connection
7	Data +	grey or yellow	RS485-parameter channel
8	Data -	green or purple	RS485-parameter channel

The GND-(0V) connection of the supply voltage has no connection to the housing.

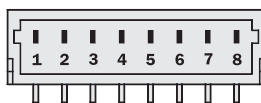

**Accessories**

Connection systems
Mounting systems
Programming Tool



Technische Daten nach DIN 32878		SEK/SEL37 radial connector		SEK	SEL								
<b>Number of sine/cosine periods per revolution</b>	16												
<b>Number of the absolute ascertainable revolutions</b>	Single SEK 1 Multi SEL 4,096												
<b>Dimensions</b>	mm (see dimensional drawing)												
<b>Mass</b>	0.04 kg												
<b>Moment of inertia to the rotor</b>	1 gcm <sup>2</sup>												
<b>Code type for the absolut value</b>	Binary												
<b>Code sequence for clockwise shaft rotation, looking in direction "A" (see dimensional drawing)</b>	Increasing												
<b>Measurement step at interpolation of the sine/cosine signals with e. g. 12 bits</b>	20 angular seconds												
<b>Error limits for evaluating the sine/cosine signals</b>													
integral non-linearity	± 288 angular seconds												
<b>Non-linearity within a sine/cosine period</b>													
differential non-linearity	± 144 angular seconds <sup>1)</sup>												
<b>Working speed up to which the absolute position can be reliably produced</b>	6,000 min <sup>-1</sup>												
<b>Max. Operating speed</b>	Single SEK and Multi SEL 12,000 min <sup>-1</sup>												
<b>Max. angular acceleration</b>	5 x 10 <sup>5</sup> rad/s <sup>2</sup>												
<b>Permissible shaft movement</b>													
axial	± 0.3 mm												
radial	± 0.15 mm												
<b>Working temperature range</b>	Single SEK - 40 ... + 115 °C Multi SEL - 20 ... + 115 °C												
<b>Storage temperature range<sup>2)</sup></b>	- 50 ... + 125 °C												
<b>Permissible relative humidity</b>	90 % <sup>3)</sup>												
<b>Resistance</b>													
To shocks <sup>4)</sup>	100 g/10 ms												
To vibration <sup>5)</sup>	50 g/10 ... 2000 Hz												
<b>Protection class to IEC 60529<sup>6)</sup></b>	IP 20												
<b>EMC<sup>7)</sup></b>													
<b>Operating voltage range</b>	7 ... 12 V												
<b>Recommended supply voltage</b>	8 V												
<b>Max. operating current, no load</b>	< 50 mA												
<b>Available memory area</b>													
within EEPROM 2048 <sup>8)</sup>	1,792 bytes												
<b>Interface signals</b>													
Process data channel = SIN, REFSIN, COS, REFCOS	Analogue, differential												
Parameter channel = RS 485	Digital												

<sup>1)</sup> At nominal position ± 0.1 mm

<sup>2)</sup> Without packaging

<sup>3)</sup> Condensation not permitted

<sup>4)</sup> To EN 60068-2-27

<sup>5)</sup> To EN 60068-2-6

<sup>6)</sup> With mating connector inserted and closed cover

<sup>7)</sup> To EN 61000-6-2 and EN 61000-6-3

The EMC according to the standards quoted is achieved when the motor feedback system is mounted in an electrically conductive housing, which is connected to the central earthing point of the motor controller via a cable screen. Users must perform their own tests when other screen designs are used.

<sup>8)</sup> If applying the electronic type label, in connection with numeric controllers, attention should be paid to Patent EP 425 912 B 2; Application of the electronic type label in connection with speed regulation is exempt.

#### Ordering information

##### SEK/SEL37 radial connector

Type	Part no.	Description
SEK37-HFB0-K02	1037378	Single
SEL37-HFB0-K02	1037379	Multi

**16 sine/cosine periods**

Motor Feedback System

- 16 sine/cosine periods per revolution
- 4,096 revolutions measurable (Multiturn)
- Programming of the positional value
- Electronic type label

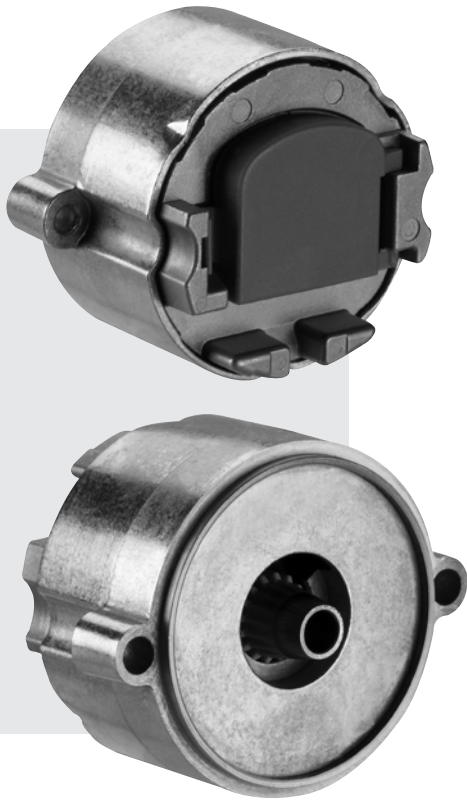

Dimensional drawing SEK/SEL37 axial connector

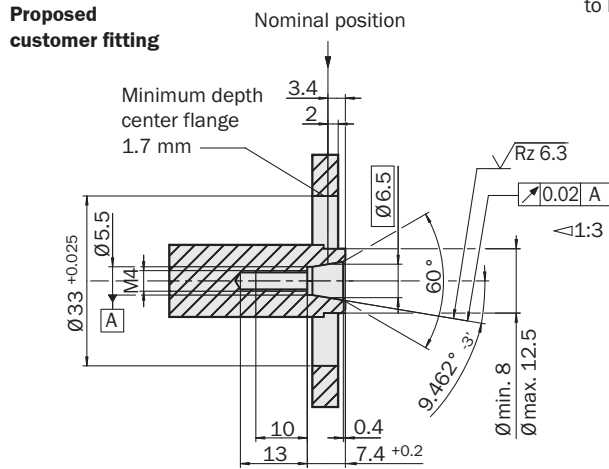
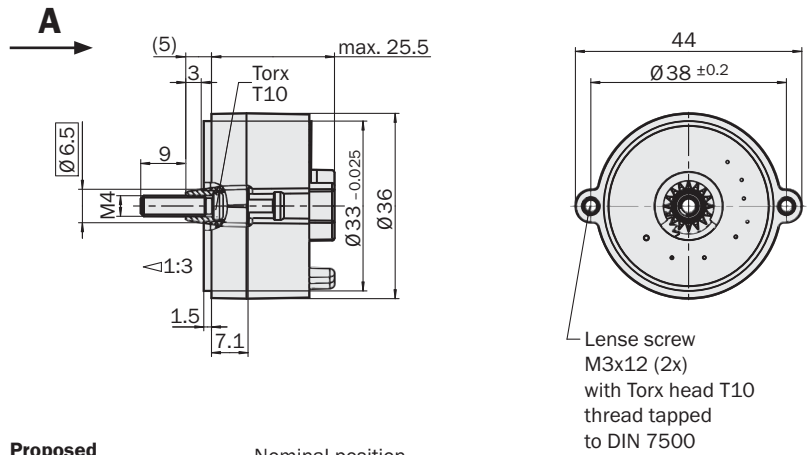

General tolerances according to DIN ISO 2768-mk

Pin and wire allocation

PIN	Signal	Colour of wires	Explanation
1	U <sub>s</sub>	red	Supply voltage 7 ... 12 V
2	+ SIN	white	Process data channel
3	REFSIN	brown	Process data channel
4	+ COS	pink	Process data channel
5	REFCOS	black	Process data channel
6	GND	blue	Ground connection
7	Data +	grey or yellow	RS485-parameter channel
8	Data -	green or purple	RS485-parameter channel

The GND-(0V) connection of the supply voltage has no connection to the housing.

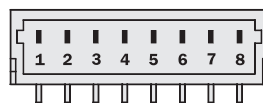

**Accessories**

Connection systems
Mounting systems
Programming Tool

Technische Daten nach DIN 32878		SEK/SEL37 axial connector	SEK	SEL								
<b>Number of sine/cosine periods per revolution</b>		16										
<b>Number of the absolute ascertainable revolutions</b>	Single SEK	1										
	Multi SEL	4,096										
<b>Dimensions</b>		mm (see dimensional drawing)										
<b>Mass</b>		0.05 kg										
<b>Moment of inertia to the rotor</b>		1 gcm <sup>2</sup>										
<b>Code type for the absolut value</b>		Binary										
<b>Code sequence for clockwise shaft rotation, looking in direction "A" (see dimensional drawing)</b>		Increasing										
<b>Measurement step at interpolation of the sine/cosine signals with e. g. 12 bits</b>		20 angular seconds										
<b>Error limits for evaluating the sine/cosine signals</b>												
integral non-linearity		± 288 angular seconds										
<b>Non-linearity within a sine/cosine period</b>												
differential non-linearity		± 144 angular seconds <sup>1)</sup>										
<b>Working speed up to which the absolute position can be reliably produced</b>		6,000 min <sup>-1</sup>										
<b>Max. Operating speed</b>	Single SEK and Multi SEL	12,000 min <sup>-1</sup>										
<b>Max. angular acceleration</b>		5 x 10 <sup>5</sup> rad/s <sup>2</sup>										
<b>Permissible shaft movement</b>												
axial		± 0.3 mm										
radial		± 0.15 mm										
<b>Working temperature range</b>	Single SEK	- 40 ... + 115 °C										
	Multi SEL	- 20 ... + 115 °C										
<b>Storage temperature range<sup>2)</sup></b>		- 50 ... + 125 °C										
<b>Permissible relative humidity</b>		90 % <sup>3)</sup>										
<b>Resistance</b>												
To shocks <sup>4)</sup>		100 g/10 ms										
To vibration <sup>5)</sup>		50 g/10 ... 2000 Hz										
<b>Protection class to IEC 60529<sup>6)</sup></b>		IP 40										
<b>EMC<sup>7)</sup></b>												
<b>Operating voltage range</b>		7 ... 12 V										
<b>Recommended supply voltage</b>		8 V										
<b>Max. operating current, no load</b>		< 50 mA										
<b>Available memory area</b>												
within EEPROM 2048 <sup>8)</sup>		1,792 bytes										
<b>Interface signals</b>												
Process data channel = SIN, REFSIN, COS, REFCOS		Analogue, differential										
Parameter channel = RS 485		Digital										

<sup>1)</sup> At nominal position ± 0.1 mm

<sup>2)</sup> Without packaging

<sup>3)</sup> Condensation not permitted

<sup>4)</sup> To EN 60068-2-27

<sup>5)</sup> To EN 60068-2-6

<sup>6)</sup> With mating connector inserted and closed cover

<sup>7)</sup> To EN 61000-6-2 and EN 61000-6-3

The EMC according to the standards quoted is achieved when the motor feedback system is mounted in an electrically conductive housing, which is connected to the central earthing point of the motor controller via a cable screen.

Users must perform their own tests when other screen designs are used.

<sup>8)</sup> If applying the electronic type label, in connection with numeric controllers, attention should be paid to Patent EP 425 912 B 2; Application of the electronic type label in connection with speed regulation is exempt.

#### Ordering information

##### SEK/SEL37 axial connector

Type	Part no.	Description
SEK37-HFA0-K02	1037376	Single
SEL37-HFA0-K02	1037377	Multi



Electrical interface

- Safe data transmission
- High information content
- Electronic type label
- Only 8 leads
- Bus-enabled parameter channel
- Process data channel in real time

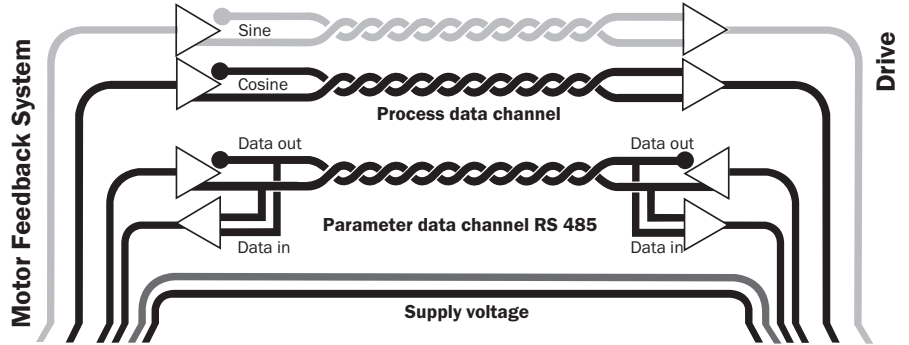

HIPERFACE® Starting time

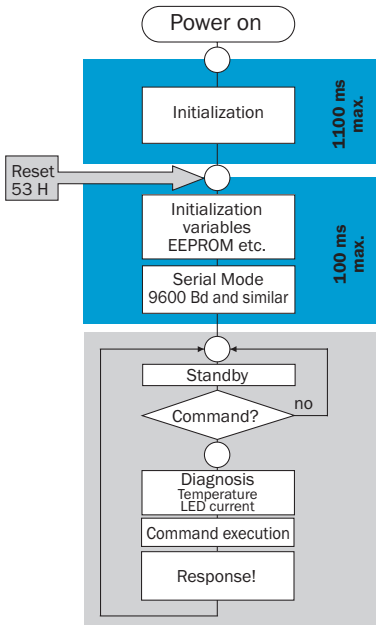

**CAUTION:**  
No **RS485** communication is possible during the phases highlighted in blue

Signal specification of the process data channel

Signal diagram for clockwise rotation of the shaft, looking in direction "A"

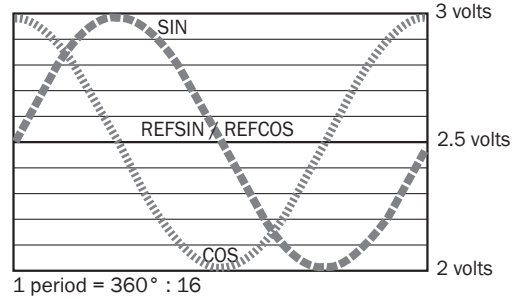

Access to the process data used for speed control, i.e. to the sine and cosine signals, is practically always "online". When the supply voltage is applied, the speed controller has access to this information at any time.

Sophisticated technology guarantees stable amplitudes of the analogue signals across all specified environmental conditions, with a maximum variation of only  $\pm 20\%$ .

Characteristics applicable to all permissible environmental conditions

Signal	Value/Units
Signal peak, peak $V_{SS}$ of SIN, COS	0.8 ... 1.2 V
Signal offset REFSIN, REFCOS	2.2 ... 2.8 V

Recommended receiver circuit for sine and cosine signals

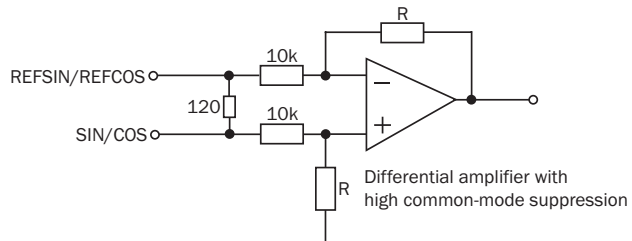



Type-specific settings	SEK37/SEK52	SEL37/SEL52
Type ID (command 52h)	42h	47h
Free EEPROM [bytes]	1,792	1,792
Address	40h	40h
Mode_485 <sup>1) 2)</sup>	E4h	E4h
Codes 0 ... 3	55h	55h
Counter	0	0

<sup>1)</sup> The baud rate 9600 is set by default. Other baud rates cannot be selected.

<sup>2)</sup> When using the motor feedback systems SEK|SEL37 and SEK|SEL52, please ensure that the controller's auto-baud function is not enabled, since these motor feedback systems compensate for minor variations when transmitting at a baud rate of 9600.

<sup>3)</sup> The commands thus labelled include the parameter "Code 0". Code 0 is a byte inserted into the protocol, for additional safeguarding of vital system parameters against accidental overwriting. When shipped, "Code 0" = 55h.

<sup>4)</sup> Temperature compatible with SCx (encoder temperature [°C] \*2.048 - 40)

Overview of commands supported			SEK37/SEK52	SEL37/SEL52
Command byte	Function	Code 0 <sup>3)</sup>	Comments	Comments
42h	Read position (5 bits per sine/cosine period)		9 bits	21 bits
43h	Set position	•		
44h	Read analogue value		Channel number F0h <sup>4)</sup> and 48h	Channel number F0h <sup>4)</sup> and 48h
			Temperature [°C]	Temperature [°C]
46h	Read counter			
47h	Increase counter			
49h	Reset counter	•		
4Ah	Read data			
4Bh	Save data			
4Ch	Determine status of a data field			
4Dh	Create data field			
4Eh	Determine available memory area			
4Fh	Change access code			
50h	Read encoder status			
52h	Read out name plate		Encoder type = 42h	Encoder type = 47h
53h	Encoder reset			
55h	Allocate encoder address	•		
56h	Read serial number and program version			

Overview of status messages				
Error type	Status code	Description	SEK37/52	SEL37/52
	00h	The encoder has recognised no error	•	•
Initialisation	01h	Faulty compensating data	•	•
	02h	Faulty internal angular offset	•	•
	03h	Data field partitioning table damaged	•	•
	04h	Analogue limit values not available	•	•
	05h	Internal I <sup>2</sup> C bus not operational	•	•
	06h	Internal checksum error	•	•
Protocol	07h	Encoder reset occurred as a result of program monitoring	•	•
	09h	Parity error	•	•
	0Ah	Checksum of the data transmitted is incorrect	•	•
	0Bh	Unknown command code	•	•
	0Ch	Number of data transmitted is incorrect	•	•
	0Dh	Command argument transmitted is not allowed	•	•
Data	0Eh	The selected data field must not be written to	•	•
	0Fh	Incorrect access code	•	•
	10h	Size of data field stated cannot be changed	•	•
	11h	Word address stated, is outside data field	•	•
	12h	Access to non-existent data field	•	•
Position	1Fh	Speed too high, no position formation possible	•	•
	20h	Singleturn position unreliable	•	•
	21h	Positional error Multiturn		•
	22h	Positional error Multiturn		•
	23h	Positional error Multiturn		•
Other	1Ch	Monitoring the value of the analogue signals (process data)	•	•
	1Eh	Encoder temperature critical	•	•
	08h	Counter overflow	•	•

Further informations to the interface see HIPERFACE®-description part no. 8010701

Dimensional drawings and ordering information

Stranded cable/connector, straight, 8 wires, 8 x 0.15 mm<sup>2</sup>

Type	Part no.	Contacts	Wire length
DOL-OJ08-GOM2XB6	2031086	8	0.2 m

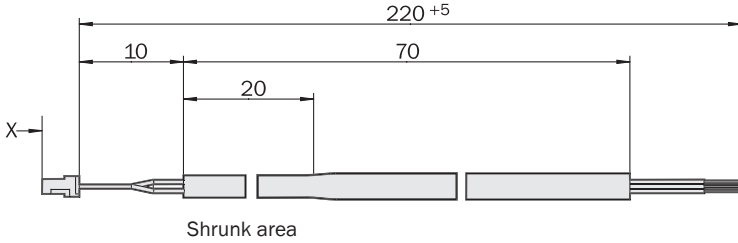

Assembly tool for SEK/SEL52 hollow shaft

Type	Part no.	Description
BEF-MW-SEY52	2048235	Assembly tool SEK/SEL52

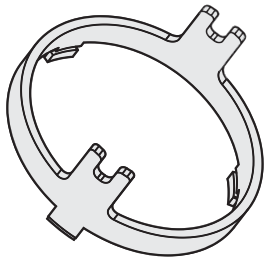

Servo clamp, Set (contents 3 off)

Type	Part no.	Description
BEF-WK-RESOL	2039082	Servo clamp for SEK/SEL52 (Hollow shaft and tapered shaft)

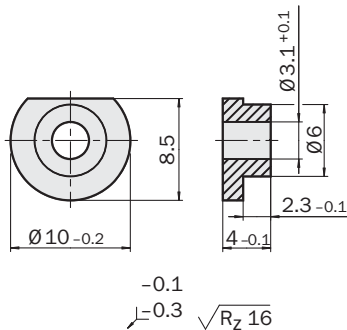

Servo clamp, Set (contents 3 off)

Type	Part no.	Description
BEF-WK-RESOL1	2048827	Servo clamp for SEK/SEL52 (Collar clamping)

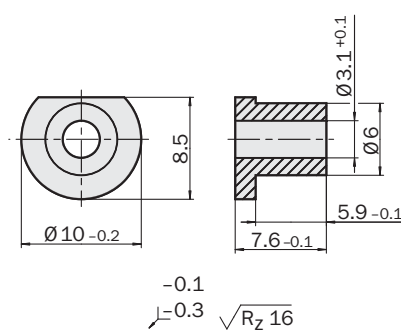

Cable HIPERFACE®, 8 wires, per metre 4 x 2 x 0,15 mm<sup>2</sup>

Type	Part no.	Wires
LTG-2708-MW	6028361	8

Programming Tool for HIPERFACE® devices

Type	Part no.	Motor Feedback System
PGT-03-S	1034252	SEK/SEL37 and SEK/SEL52

## Dimensional drawings and ordering information

## Cover SEK/SEL52 with tapered shaft or collar clamping

Type	Part no.	Description
BEF-GA-SEY52BS1	2048234	Cover closed



## Abdeckung SEK/SEL52 mit Hohlwelle

Type	Part no.	Description
BEF-GA-SEY52TS1	2048232	Cover opened



**Australia**

Phone +61 3 9497 4100  
1800 33 48 02 – tollfree  
E-Mail sales@sick.com.au

**Belgium/Luxembourg**

Phone +32 (0)2 466 55 66  
E-Mail info@sick.be

**Brasil**

Phone +55 11 3215-4900  
E-Mail sac@sick.com.br

**Ceská Republika**

Phone +420 2 57 91 18 50  
E-Mail sick@sick.cz

**China**

Phone +852-2763 6966  
E-Mail ghk@sick.com.hk

**Danmark**

Phone +45 45 82 64 00  
E-Mail sick@sick.dk

**Deutschland**

Phone +49 211 5301-250  
E-Mail info@sick.de

**España**

Phone +34 93 480 31 00  
E-Mail info@sick.es

**France**

Phone +33 1 64 62 35 00  
E-Mail info@sick.fr

**Great Britain**

Phone +44 (0)1727 831121  
E-Mail info@sick.co.uk

**India**

Phone +91-22-4033 8333  
E-Mail info@sick-india.com

**Israel**

Phone +972-4-999-0590  
E-Mail info@sick-sensors.com

**Italia**

Phone +39 02 27 43 41  
E-Mail info@sick.it

**Japan**

Phone +81 (0)3 3358 1341  
E-Mail support@sick.jp

**Nederlands**

Phone +31 (0)30 229 25 44  
E-Mail info@sick.nl

**Norge**

Phone +47 67 81 50 00  
E-Mail austefjord@sick.no

**Österreich**

Phone +43 (0)22 36 62 28 8-0  
E-Mail office@sick.at

**Polska**

Phone +48 22 837 40 50  
E-Mail info@sick.pl

**Republic of Korea**

Phone +82-2 786 6321/4  
E-Mail kang@sickkorea.net

**Republika Slovenija**

Phone +386 (0)1-47 69 990  
E-Mail office@sick.si

**România**

Phone +40 356 171 120  
E-Mail office@sick.ro

**Russia**

Phone +7 495 775 05 34  
E-Mail info@sick-automation.ru

**Schweiz**

Phone +41 41 619 29 39  
E-Mail contact@sick.ch

**Singapore**

Phone +65 6744 3732  
E-Mail admin@sicksgp.com.sg

**Suomi**

Phone +358-9-25 15 800  
E-Mail sick@sick.fi

**Sverige**

Phone +46 10 110 10 00  
E-Mail info@sick.se

**Taiwan**

Phone +886 2 2375-6288  
E-Mail sickgrc@ms6.hinet.net

**Türkiye**

Phone +90 216 587 74 00  
E-Mail info@sick.com.tr

**USA/Canada/México**

Phone +1(952) 941-6780  
1 800-325-7425 – tollfree  
E-Mail info@sickusa.com

More representatives and agencies  
in all major industrial nations at  
**www.sick.com**