

## MODEL RLY5 - SOLID STATE POWER UNIT

- SWITCHES UP TO 45 AMPERES @ 240 VAC
- LOW LEVEL DC INPUT CONTROL SIGNAL (3-32 VDC)
- OPTICALLY-ISOLATED OUTPUT
- ZERO VOLTAGE TURN-ON, ZERO CURRENT TURN-OFF FOR REDUCED RFI
- INTERNAL SNUBBERS TO REDUCE FALSE TRIGGERING RELATED TO HIGH dv/dt APPLICATIONS
- SUPPLIED WITH HIGH EFFICIENCY HEATSINK FOR SUPERIOR THERMAL and SURGE CURRENT RATINGS



### GENERAL DESCRIPTION

The SSR Power Unit is a solid state relay which can switch load currents up to 45 Amperes @ 240 VAC. The unit interfaces directly with a SSR Drive Module (OMD00003). The input and output terminals are isolated from each other to eliminate ground loops and noise problems. The unit features a zero voltage turn-on and a zero current turn-off detector to minimize radiated RFI when switching. An internal snubber minimizes inrush currents and guards against false triggering of the output; related to high dv/dt applications. A low DC control signal of +3 to +32 VDC is all that is needed for the switching operation. The solid state switch, highlighted by the inverse-parallel SCR output, provides a greatly increased operational life over a mechanical relay by avoiding the usual relay contact problems: arcing, bouncing, mechanical failure, etc. The solid state relay is shipped mounted to the high efficiency heatsink for immediate installation.

### SPECIFICATIONS

#### OUTPUT SPECIFICATIONS

1. **Operating Voltage Range:** 50-280 VAC RMS
2. **Operating Frequency Range:** 47-63 Hz
3. **Maximum Continuous Load Current:** See Thermal Rating Code
4. **Maximum Surge Load Current:** See Peak Surge Current Curve
5. **Minimum Load Current:** 40 mA RMS
6. **Maximum Off-State Leakage Current:** 10 mA RMS
7. **Maximum Transient Voltage:** 600 V peak
8. **Maximum Output Voltage Drop:** 1.6 V peak
9. **Power Dissipation at Full Load:** 50 Watts
10. **Maximum I<sup>2</sup>T:** 1600A<sup>2</sup>sec  
(For Fusing Purposes, t = 8.3 msec)
11. **Minimum Off-State dv/dt protection:** 500 V/usec

#### INPUT SPECIFICATIONS

(Use with RLC SSR Drive Module, OMD00003)

1. **Control Voltage Range:** 3 to 32 VDC
2. **Maximum Turn-on Voltage:** 3 VDC
3. **Minimum Turn-off Voltage:** 1 VDC
4. **Maximum Reverse Voltage:** -32 VDC
5. **Minimum Input Impedance:** 1500 Ω
6. **Maximum Turn-on/Turn-off time:** 8.3 msec

#### GENERAL SPECIFICATIONS

1. **Isolation (Input to Output to Base):** 4000 V RMS
2. **Insulation Resistance:** 10 GΩ
3. **Operating Temperature Range:** -30° to +75°C
4. **Storage Temperature Range:** -40° to +120°C

### INSTALLATION

It is recommended to mount the unit outside of an enclosure in an area where there is unrestricted air flow. The unit should always be mounted with the fins in a vertical position to maximize heat dissipation. If mounting the unit inside an enclosure, the internal temperature of the enclosure will normally be higher than the surrounding area and must be accounted for. At full rated load, the unit will dissipate 50 watts and achieve a case temperature in excess of 90°C. In all installations, it is important to allow at least two inches around the power unit for proper ventilation.

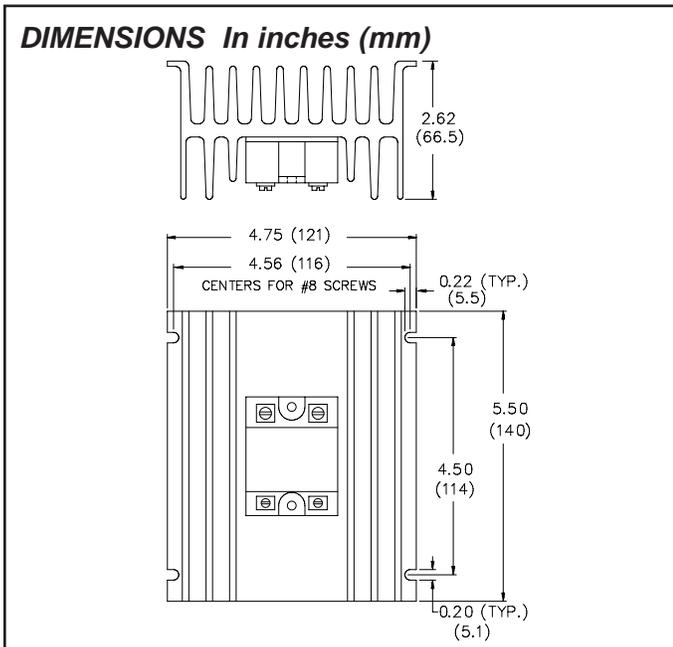

### ORDERING INFORMATION

MODEL	DESCRIPTION	PART NUMBER
RLY5	SSR Power Unit	RLY50000

## CONNECTIONS

Separate power feed lines should be run to the load side of the relay. The controller unit and the load should NEVER share the same power feed. It is recommended to install the SSR Power Unit as close to the load as possible to keep the power cable runs short. This will help reduce noise from radiating into other equipment. The input control signal cable can be run over distances in excess of 200 ft. with shielded cable from the controller to the SSR power unit. Connect the shield to the minus "-" terminal of the control signal, on the SSR Power Unit and at only one end.

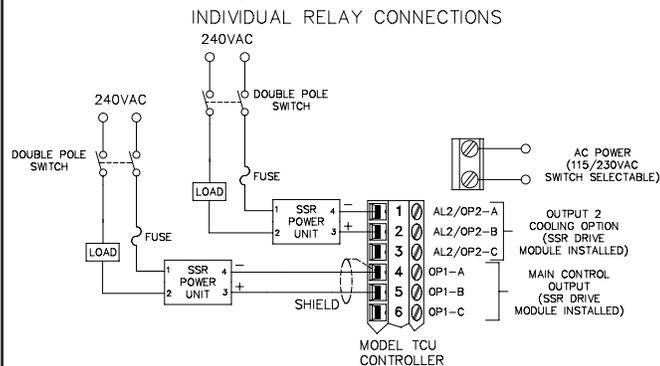

## MULTIPLE UNITS

For increased power handling, up to four SSR Power Units may be parallel connected, and all controlled by a single output of an SSR Drive Module (OMD00003). The output of the SSR Power Units must NOT be parallel connected to the same load because of unequal current sharing among the devices. The outputs should be wired to individual heaters, but they may share the same supply. If five or more SSR Power Units are required, a Relay Output Module (OMD00000) may be used in conjunction with an external +12 VDC power source (RLC Model APS01000) to switch the SSR Power Units.

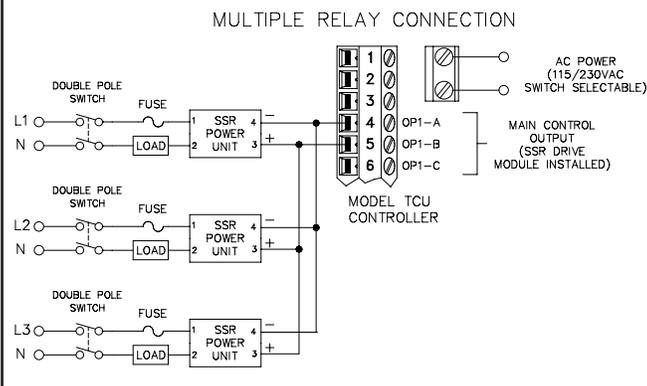

## OPERATION

The following are important aspects of operation of the SSR power unit which must be considered. Adhering to these guidelines will ensure reliable and trouble free operation.

## THERMAL RATING CURVES

The Thermal Rating Curve will determine the maximum allowable ambient operating temperature for the maximum continuous load current. The two parameters must intersect in the Safe Operating Area of the graph. Operation outside the safe operating area will shorten the life of or cause permanent damage to the SSR Power Unit. The ambient temperature of the power unit should be measured with all of the associated equipment operating to verify the Thermal Ratings.

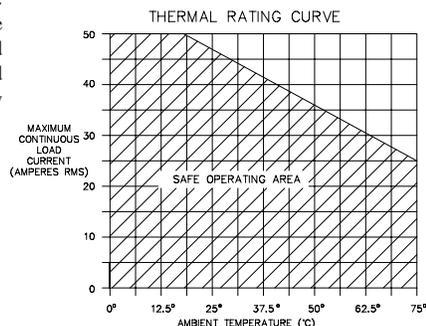

## SURGE CURRENT

When the SSR Power Unit switches a load on, an in-rush (surge) current that is higher than the continuous load current will flow. The surge current can be estimated from the table below which outlines the ratio of surge to steady state current for various load devices. The surge current duration must be within the Safe Operating Area of the Peak Surge Current vs. Time Figure. Surge currents outside the safe operating area will shorten the life of or cause permanent damage to the power unit.

Load Device	Ratio Surge Current to Steady State Current
Incandescent Bulbs (cold)	5
Quartz Heaters (cold)	7
Motors (motionless)	10
Compressors	10

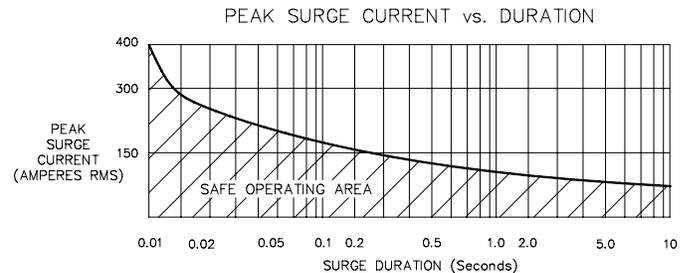

## FUSING

The output of the SSR Power Unit should be protected by a fast blow I<sup>2</sup>t fuse (Bussman KAX-30 or equivalent). This guards against long duration surge currents, short circuits, etc., which may damage the SSR Power Unit.

## MECHANICAL INTERRUPT SWITCH

The off-state output leakage current of the power unit is 10 mA maximum. The voltage level of the output will rise proportional to the resistance of the load due to this leakage current. Full line voltage can be measured when the output is connected to a high resistance load and the power unit is in the off-state.

A mechanical interrupt switch (double pole) should be placed between both sides of the line voltage and the load. The switch should be opened when servicing any part of the output wiring. When measuring the off-state output voltage of the unit for correct operation, load the output of the SSR Power Unit with a small resistance (approximately 100 ohms).

## SNUBBING

The power unit has internal snubbers to guard against transients generated by most loads. Loads with low power factors (ie. motors) may require additional external snubbing network.