

MODEL ICM5 – THREE WAY ISOLATED SERIAL CONVERTER MODULE (RS232C/RS485)



- 9 PIN D-SUB CONNECTOR FOR RS232 CONNECTION
- SWITCHABLE TERMINATION AND BIASING RESISTORS
- MODULAR RJ JACK OR SCREW TERMINAL FOR RS485 CONNECTION

- ALLOWS COMMUNICATIONS BETWEEN RS232 CONTROL EQUIPMENT AND PRODUCTS WITH RS422/RS485 SERIAL COMMUNICATIONS
- THREE WAY ISOLATION PROTECTS SERIAL EQUIPMENT FROM GROUND LOOPS (1000 VDC)
- AUTOMATIC RS485 DRIVER CONTROL
- DIP SWITCH SELECTABLE BAUD RATES 9600, 19200, 38400, 57600, 115200
- WIDE DC INPUT POWER RANGE (+9 to 26 VDC)
- HALF DUPLEX (RS485) AND FULL DUPLEX (RS422)
- LED INDICATION FOR RXD, TXD, and POWER
- UNIVERSAL MOUNTING FOOT FOR DIN RAIL INSTALLATION
- SELECTABLE DTE & DCE OPERATION WORKS WITH ANY RS232 CABLE



UL Recognized Component,
 File # E179259

DESCRIPTION

The ICM5 Serial Converter Module provides the capability of interfacing equipment with RS485 serial communications to equipment with RS232 communications while providing three way isolation. Data format of the RS232 and RS485 equipment must be the same.

The unit can be configured for full duplex (RS422), or half duplex (RS485) operation. In half duplex mode, the RS485 driver is automatically enabled using the leading edge of the first character that is received on the RS232 side. After the last character is received, the converter waits one character time (at the selected baud rate) to disable the RS485 driver.

An external DC power source (+9 to 26 VDC) is required to power the ICM5. The external power source and RS485 communications connections are made via a 7-position removable terminal block located on the front of the module. A modular RS485 connector is also provided for fast and efficient connection to other Red Lion devices that use a modular connector. The RS232 connection is provided via a standard D-SUB 9-pin male connector. The ICM5 can be configured for DTE or DCE operation, allowing the use of modem or null-modem cables.

There are 3 LEDs that can be viewed from the front of the converter module. A green power LED indicates power is on, a red RS232 TXD LED flashes when the module is transmitting, and a green RS232 RXD LED flashes when the module is receiving.

The unit is equipped with a universal mounting foot for attachment to standard DIN style mounting rails, including top hat profile rail according to EN 50 022 - 35x7.5 and 35x15, and G profile rail according to EN 50 035 - G32.

SAFETY SUMMARY

All safety related regulations, local codes and instructions that appear in the manual or on equipment must be observed to ensure personal safety and to prevent damage to either the instrument or equipment connected to it. If equipment is used in a manner not specified by the manufacturer, the protection provided by the equipment may be impaired.

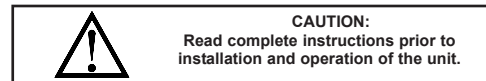

SPECIFICATIONS

- POWER:** +9 to 26 VDC @ 125 mA maximum, 85 mA typical
 Power Supply must be Class 2 or SELV rated.
- RS232 VOLTAGES:**
Receive Data Pin: ± 30 VDC max.
Mark Condition: ≤ 0.8 VDC
Space Condition: ≥ 2.4 VDC
Transmit Data Pin:
Mark Condition: -8 VDC (typ.)
Space Condition: +8 VDC (typ.)
- RS485 VOLTAGES:**
Differential Output Voltage: ± 5 VDC max. under no load
Differential Input Voltage: ± 5 VDC max.
Mark Condition: ≤ -0.2 VDC
Space Condition: ≥ +0.2 VDC
RS485 Drive Capability: Up to 32 RS485 receivers connected in parallel
RS485 Drive Disable Time: one character time (at the set baud rate)
- MAXIMUM CABLE LENGTH:**
RS232: 50 feet (15.24 m)
RS485: 4000 feet (1219.2 m)
- BAUD RATE:** 9600 min., 115200 max.
- ISOLATION:** 1000 VDC
- ENVIRONMENTAL CONDITIONS:**
Operating Temperature Range: 0 to 50°C.
Storage Temperature: -40 to + 75°C
Operating and Storage Humidity: 85% max. relative humidity (non-condensing) from 0 to 50°C
Altitude: Up to 2000 meters

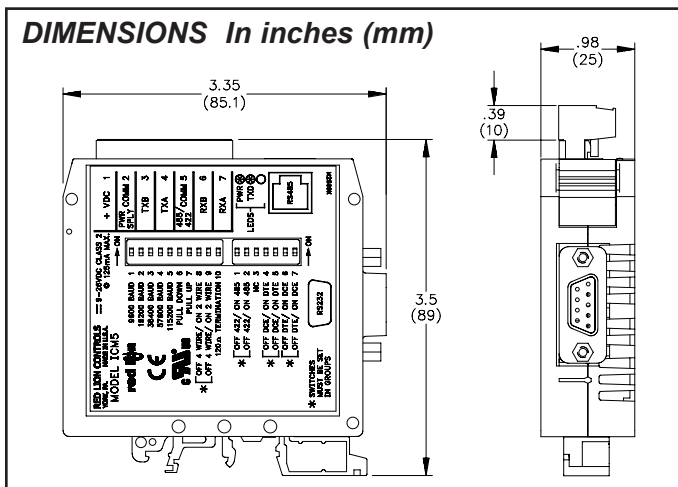

8. CERTIFICATIONS AND COMPLIANCES:

SAFETY

UL Recognized Component, File #E179259, UL3101-1, CSA 22.2 No. 1010-1
 Recognized to U.S. and Canadian requirements under the Component
 Recognition Program of Underwriters Laboratories, Inc.
 IECCE CB Scheme Test Certificate #US/5141A/UL,
 CB Scheme Test Report #01ME11540-0702001
 Issued by Underwriters Laboratories, Inc.
 IEC 61010-1, EN 61010-1: Safety requirements for electrical equipment
 for measurement, control, and laboratory use, Part 1.

ELECTROMAGNETIC COMPATIBILITY

Immunity to EN 50082-2

| | | |
|---------------------------|--------------|----------------------------------------------------------------------|
| Electrostatic discharge | EN 61000-4-2 | Level 2; 4 Kv contact ¹ Level 3; 8 Kv air ¹ |
| Electromagnetic RF fields | EN 61000-4-3 | Level 3; 10 V/m 80 MHz - 1 GHz |
| Fast transients (burst) | EN 61000-4-4 | Level 4; 2 Kv I/O Level 3; 2 Kv power |
| RF conducted interference | EN 61000-4-6 | Level 3; 10 V/rms 150 KHz - 80 MHz |

Emissions to EN 50081-1

| | | |
|-----------------|----------|------------------------------------------|
| RF interference | EN 55022 | Enclosure class B Power mains class B |
|-----------------|----------|------------------------------------------|

Note:

1. This device was designed for installation in an enclosure. To avoid electrostatic discharge to the unit in environments with static levels above 4 Kv, precautions should be taken when the device is mounted outside an enclosure. When working in an enclosure, (ex. making adjustments, setting switches etc.) typical anti-static precautions should be observed before touching the unit.

Refer to EMC Installation Guidelines for additional information.

9. **CONSTRUCTION:** Case body is black, high impact plastic. Installation Category I, Pollution Degree 2.

10. **MOUNTING:** Standard DIN rail top hat (T) profile rail according to EN50022- 35 X 7.5 and 35 X 15

11. **WEIGHT:** 3.3 oz. (93.6 g)

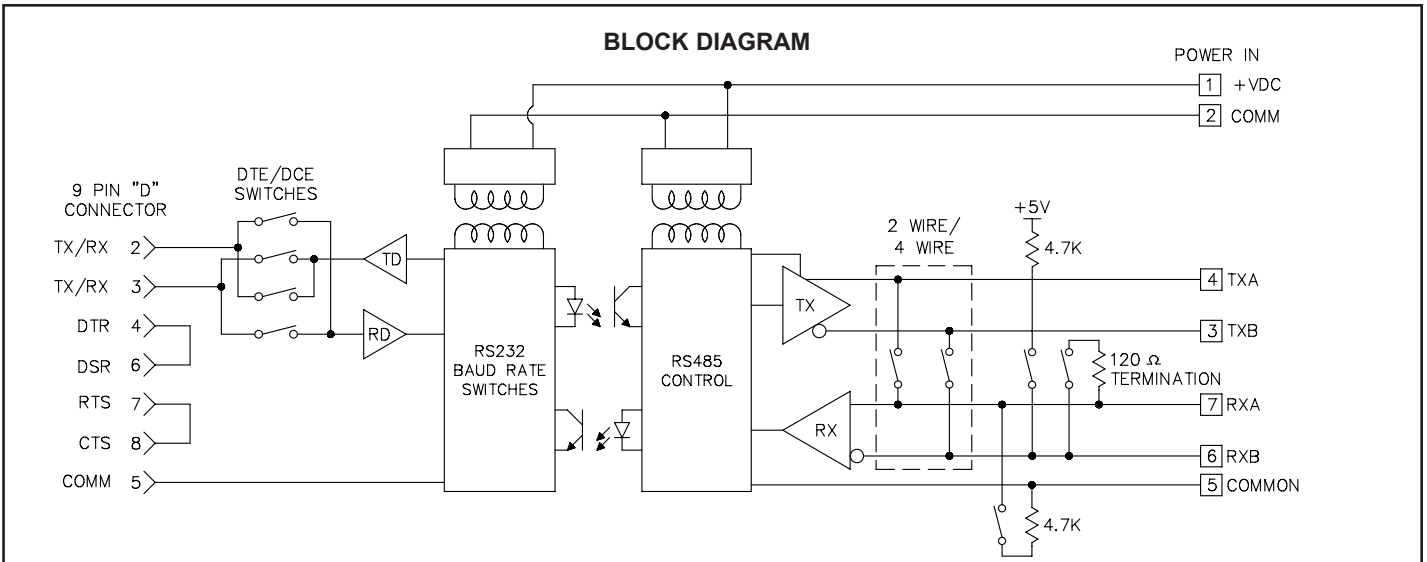

EMC INSTALLATION GUIDELINES

Although this unit is designed with a high degree of immunity to ElectroMagnetic Interference (EMI), proper installation and wiring methods must be followed to ensure compatibility in each application. The type of electrical noise, source or coupling method into the unit may be different for various installations. In extremely high EMI environments, additional measures may be needed. Cable length, routing and shield termination are very important and can mean the difference between a successful or a troublesome installation. Listed below are some EMC guidelines for successful installation in an industrial environment.

- DC power to the unit should be relatively clean and within the specified limits. Connecting power to the unit from circuits that power inductive loads that cycle on and off, such as contactors, relays, motors, etc., should be avoided. This will reduce the chance of noise spikes entering the DC power connection and affecting the unit.
- The shield (screen) pigtail connection should be made as short as possible. The connection point for the shield depends somewhat upon the application. Listed below are the recommended methods of connecting the shield, in order of their effectiveness.
 - Connect the shield only at the unit to earth ground (protective earth).
 - Connect the shield to earth ground at both ends of the cable, usually when the noise source frequency is above 1 MHz.
 - Connect the shield to common of the unit and leave the other end of the shield unconnected and insulated from earth ground.

3. Never run Signal cables in the same conduit or raceway with AC power lines, conductors feeding motors, solenoids, SCR controls, and heaters, etc. The cables should be run in metal conduit that is properly grounded. This is especially useful in applications where cable runs are long and portable two-way radios are used in close proximity or if the installation is near a commercial radio transmitter.

4. Signal cables within an enclosure should be routed as far away as possible from contactors, control relays, transformers, and other noisy components.

5. In extremely high EMI environments, the use of external EMI suppression devices, such as ferrite suppression cores, is effective. Install them on Signal cables as close to the unit as possible. Loop the cable through the core several times or use multiple cores on each cable for additional protection.

Install line filters on the power input cable to the unit to suppress power line interference. Install them near the power entry point of the enclosure. The following EMI suppression devices (or equivalent) are recommended:

Ferrite Suppression Cores for signal cables:
 Fair-Rite # 0443167251 (RLC #FCOR0000)
 TDK # ZCAT3035-1330A
 Steward #28B2029-0A0

Line Filters for input power cables:
 Schaffner # FN610-1/07 (RLC #LFIL0000)
 Schaffner # FN670-1.8/07
 Corcom #1VR3

Note: Reference manufacturer's instructions when installing a line filter.

6. Long cable runs are more susceptible to EMI pickup than short cable runs. Therefore, keep cable runs as short as possible.

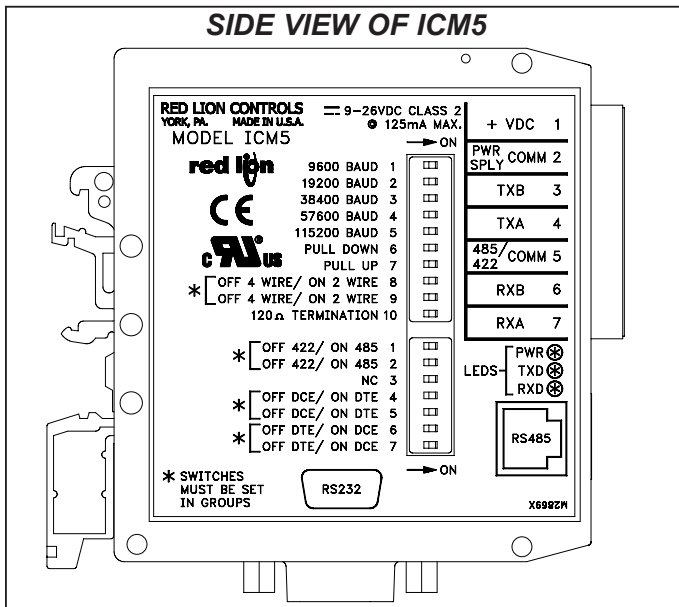

DIP SWITCH SETTINGS

Top Bank of 10 Switches

Switches 1-5 - BAUD

Select the appropriate baud rate. This adjusts the time delay for the automatic RS485 driver controller. Only one of the baud switches should be in the ON position.

Switches 6-7 - PULL UP / PULL DOWN

These switches connect 4.7 K Ω biasing resistors to the A and B lines of the 485 receiver. To minimize loading of the network, these should only be used if no other device in the system provides biasing.

Switches 8-9 - OFF 4 WIRE / ON 2 WIRE

These switches can be used to internally jumper the A and B lines of the RS485 driver and receiver together. This allows 2-wire operation without the use of external jumper wires. To use the RJ-11 connector, the ICM5 must be in 2-wire mode. Both switches should be in the same position.

Switch 10 - 120 Ω TERMINATION

This switch connects a 120 Ω resistor across the A and B lines of the RS485 receiver. The use of the resistor prevents signal reflection, or echoing, at high baud rates, over long distances. This should only be turned on if the ICM5 is the first, or last, device in a multi-drop network that is experiencing reflection due to long cable distances.

Bottom Bank of 7 Switches

Switches 1-2 - OFF 422 / ON 485

These switches enable and disable the automatic RS485 driver control. In the 422 position, the driver is always enabled, allowing 4-wire full duplex operation. In the 485 position, the driver is enabled as soon as characters are received on the RS232 side. When the RS485 driver has transmitted the last character, it waits one character time (at the selected baud rate), and then enters a high-impedance state. The receiver is also enabled and disabled in a similar fashion to prevent transmitted characters from being echoed back. This allows 2-wire, half-duplex operation, without the use of handshake lines. Both switches should be in the same position.

Switch 3 - N/C

No Connection

Switches 4-7 - OFF DCE / ON DTE

These switches configure the RS232 port to act as a DCE or DTE device. With all of the switches in the DCE position, pin 2 of the DB-9 connector is the RS-232 receiver, and pin 3 is the RS232 transmitter. DTE configures pin 2 as the transmitter, and pin 3 as the receiver. These switches allow the use of modem or null-modem cables. All of these switches should be in the DCE or DTE position. No other combinations are valid.

DEFAULT SETTINGS

BAUD RATE 9600
DCE
2 WIRE \ RS485
NO TERMINATION
NO PULL-UP OR PULL DOWN

TYPICAL RS232 CONNECTIONS

DCE



Note:

Connect shield (drain wire) to earth ground.

* - Application Dependent

DTE

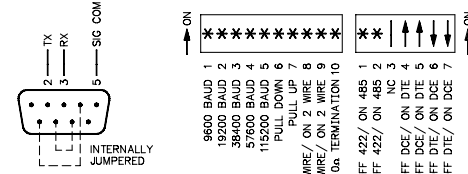

Note:

Connect shield (drain wire) to earth ground.

* - Application Dependent

TYPICAL RS422 CONNECTIONS

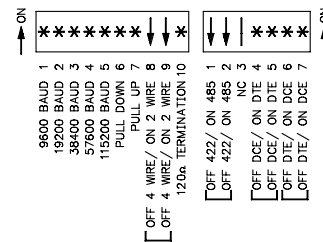
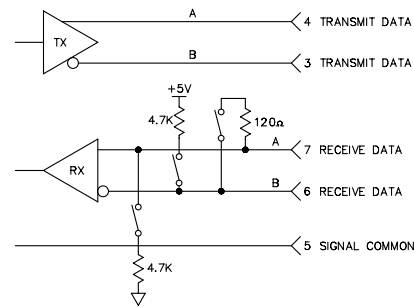

* - Application Dependent

Notes:

1. Connect shield (drain wire) to earth ground.
2. RS422 polarity: Terminal "A" is negative with respect to Terminal "B" in the mark (logic 1) condition.

TYPICAL RS485 CONNECTIONS

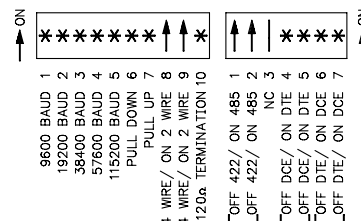
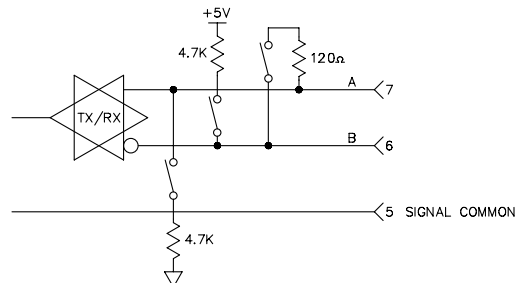

Note:

Connect shield (drain wire) to earth ground.

* - Application Dependent

TYPICAL CONNECTION FOR RS485 DEVICES

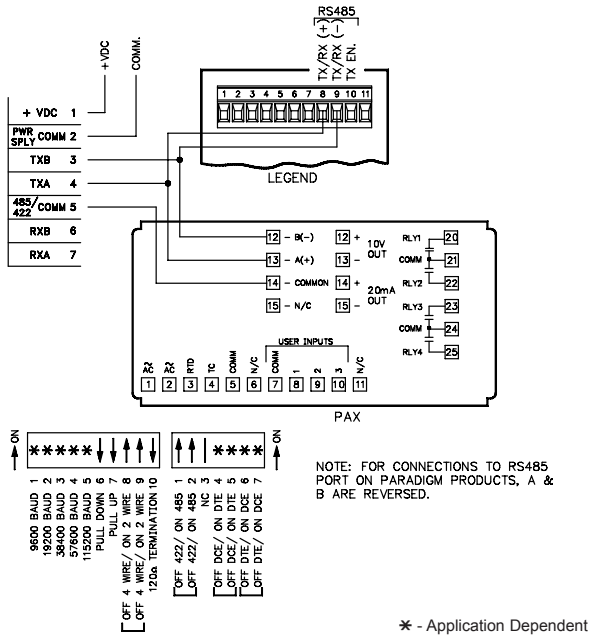

TYPICAL RS485 CONNECTIONS USING RJ-11

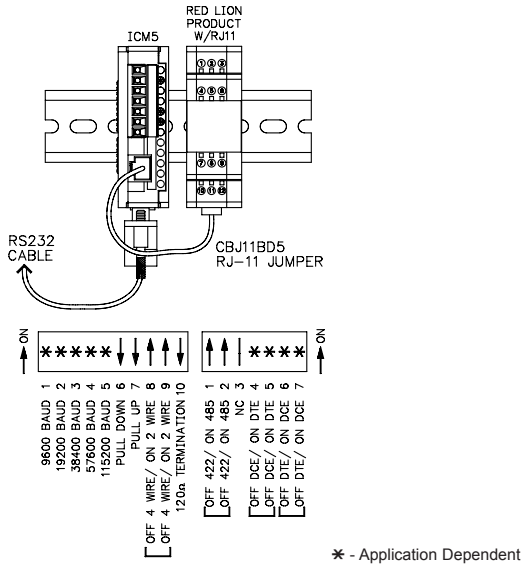

CONNECTING TO PARADIGM INTERFACE

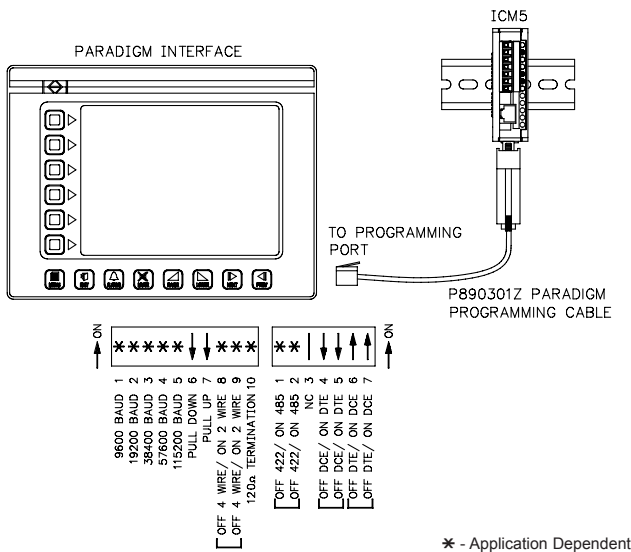

INSTALLATION

The unit is equipped with a universal mounting foot for attachment to standard DIN style mounting rails, including G profile rail according to EN50035 - G32, and top hat (T) profile rail according to EN50022 - 35 x 7.5 and 35 x 15. The unit should be installed in a location that does not exceed the maximum operating temperature and provides good air circulation. Placing the unit near devices that generate excessive heat should be avoided.

G Rail Installation

To install the ICM5 on a "G" style DIN rail, angle the module so that the upper groove of the "foot" catches under the lip of the top rail. Push the module toward the rail until it snaps into place. To remove a module from the rail, push up on the bottom of the module while pulling out away from the rail.

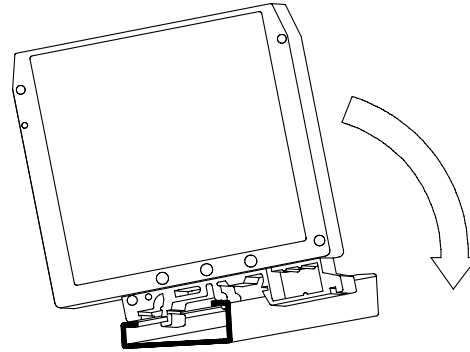

T Rail Installation

To install the ICM5 on a "T" style rail, angle the module so that the top groove of the "foot" is located over the lip of the top rail. Push the module toward the rail until it snaps into place. To remove a module from the rail, insert a screwdriver into the slot on the bottom of the "foot", and pry upwards on the module until it releases from the rail.

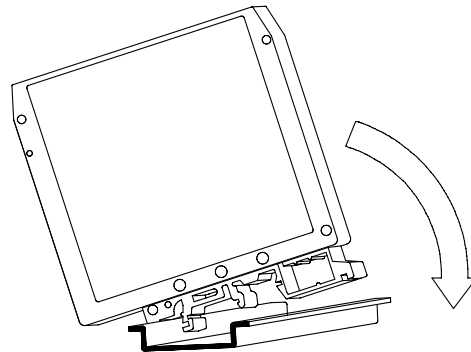

ORDERING INFORMATION

| MODEL NO. | DESCRIPTION | PART NUMBER |
|-----------|------------------------------|-------------|
| ICM5 | RS232/RS485 Converter Module | ICM50000 |
| CBJ | 6" RJ-11 Jumper Cable | CBJ11BD5 |

TROUBLESHOOTING

For further technical assistance, contact technical support at the appropriate company numbers listed.