

Select high density discrete outputs when...

...you need sixteen DC outputs to drive low power devices.

- High density outputs save space and reduce cost
- Ideal for driving indicator lights and small relays
- Isolation protects system wiring from faults
- Surge suppressors safely clamp inductive loads



Performance Specifications

Number of channels	16
Minimum output voltage	10 VDC
Maximum output voltage	32 VDC
Minimum load current (per output)	1 mA
Maximum load current (per output)	0.5 Amps
Maximum load current (per module)	8 Amps
Maximum OFF state leakage current	.01 mA
Inrush current (100 mS surge)	1.5 Amps
Output ON state voltage drop	1 VDC
Maximum ST-Bus power	600 mW
Isolation (input to ST-Bus)	1200V
Operating temperature range	-30 to 70°C
Storage temperature range	-40 to 85°C
Humidity (non-condensing)	5 to 95%

Note: The first output may be configured as a system performance watchdog. ON = OK.

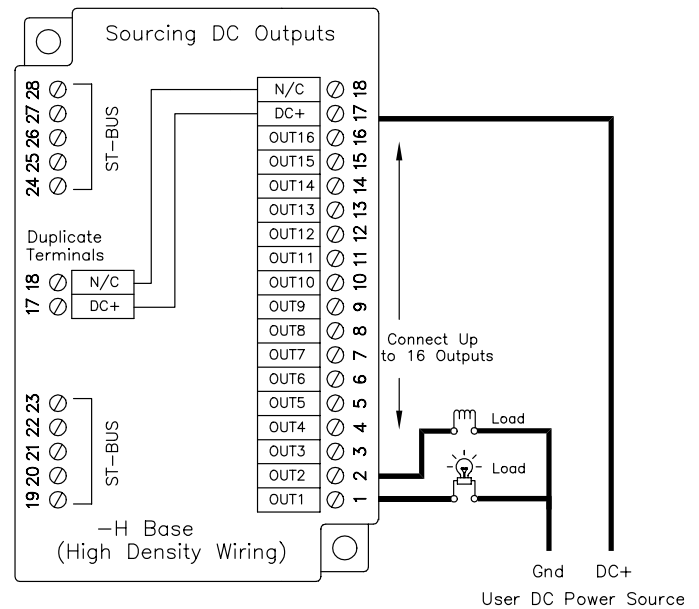

Equivalent Circuit

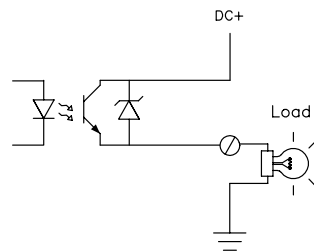

Ordering Information

Description	Part Number
16 Outputs w/Wiring Base	ST-DO-DC2-16H
Module only	ST-DO-DC2-16M