

GRAPHITE™ SERIES

9" Color Touchscreen Operator Interface

Installation Guide

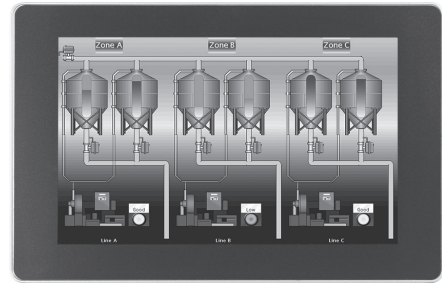

UL LISTED FOR USE IN HAZARDOUS LOCATIONS:
 Class I, Division 2, Groups A, B, C, and D
 Class II, Division 2, Groups F and G
 Class III, Division 2

IND. CONT. EQ. 3PWL

UL LISTED
 IND. CONT. EQ. 34AD



See the Red Lion website at www.redlion.net or the enclosed USB thumbdrive for full user manual, Crimson software and software manual.

SAFETY SUMMARY

All safety related regulations, local codes and instructions that appear in this literature or on equipment must be observed to ensure personal safety and to prevent damage to either the instrument or equipment connected to it. If equipment is used in a manner not specified by the manufacturer, the protection provided by the equipment may be impaired. Do not use this unit to directly command motors, valves, or other actuators not equipped with safeguards. To do so can be potentially harmful to persons or equipment in the event of a fault to the unit.



CAUTION: Risk of Danger.
 Read complete instructions prior to installation and operation of the unit.



CAUTION:
 Risk of electric shock.



WARNING - EXPLOSION HAZARD - DO NOT DISCONNECT EQUIPMENT UNLESS POWER HAS BEEN SWITCHED OFF OR AREA IS KNOWN TO BE NON-HAZARDOUS.



WARNING - EXPLOSION HAZARD - SUBSTITUTION OF COMPONENTS MAY IMPAIR SUITABILITY FOR CLASS I, DIVISION 2

ORDERING INFORMATION

| DESCRIPTION | PART NUMBER |
|---|-------------|
| 9" color touch screen, indoor use, 24 VDC powered | G09C0000 |
| 9" color touch screen, indoor use, 24 VDC powered, additional ethernet port | G09C1000 |

SPECIFICATIONS

POWER: +24 VDC ±20%

Typical Power HMI only: 13 W
 Maximum Power HMI only: 20 W
 HMI With Module(s): 45 W

Must use a Class 2 circuit according to National Electrical Code (NEC), NFPA-70 or Canadian Electrical Code (CEC), Part I, C22.1 or a Limited Power Supply (LPS) according to IEC 60950-1 or Limited-energy circuit according to IEC 61010-1.

Power connection via removable three position terminal block.

ENVIRONMENTAL CONDITIONS:

Operating Temperature Range: -20 to 60 °C
 Storage Temperature Range: -20 to 70 °C
 Vibration to IEC 68-2-6: Operational 5-500 Hz, 4 g
 Shock to IEC 68-2-27: Operational 40 g (10 g, modules w/relays)
 Operating and Storage Humidity: 0 to 85% max. RH non-condensing
 Altitude: Up to 2000 meters

CERTIFICATIONS AND COMPLIANCES:

CE Approved

EN 61326-1 Immunity to Industrial Locations
 Emission CISPR 11 Class A
 IEC/EN 61010-1
 RoHS Compliant

UL Listed: File #E302106

UL Hazardous: File #E317425

Type 4X Indoor / IP66 Enclosure rating (Face only) for all models

CONNECTIONS:

High compression cage-clamp terminal block
 Wire Strip Length: 0.3" (7.5 mm)
 Wire Gauge Capacity: One 14 AWG (2.55 mm) solid,
 two 18 AWG (1.02 mm) or four 20 AWG (0.61 mm)

CONSTRUCTION: Cast aluminum enclosure with NEMA 4X/IP66 rating for indoor use only when correctly fitted with the gasket provided. Installation Category II, Pollution Degree 2.

WEIGHT: 3.39 lb. (1.54 Kg)

DIMENSIONS In inches (mm)

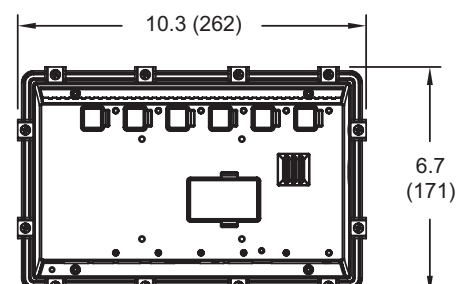
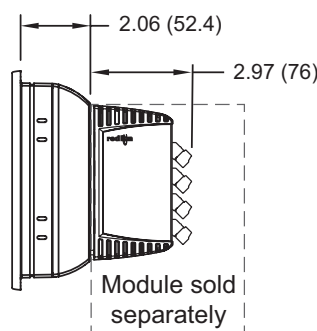
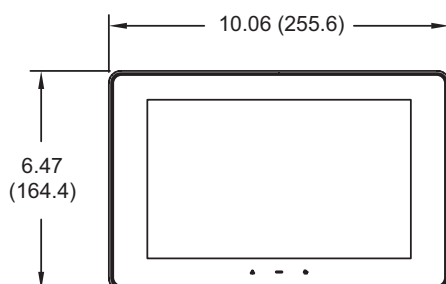

(MOUNTING CLIPS INSTALLED)

OPERATOR INTERFACE INSTALLATION

MOUNTING INSTRUCTIONS

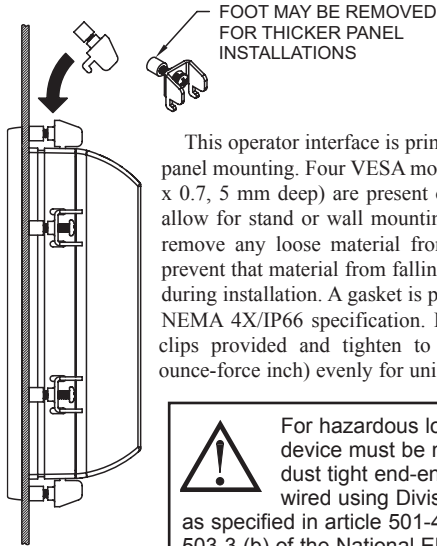

FOOT MAY BE REMOVED FOR THICKER PANEL INSTALLATIONS

This operator interface is primarily designed for through-panel mounting. Four VESA mount tapped screw-holes (M4 x 0.7, 5 mm deep) are present on the rear of the panels to allow for stand or wall mounting. Care should be taken to remove any loose material from the mounting cut-out to prevent that material from falling into the operator interface during installation. A gasket is provided to enable sealing to NEMA 4X/IP66 specification. Install the twelve mounting clips provided and tighten to 6.0 pound-force inch (96 ounce-force inch) evenly for uniform gasket compression.



For hazardous location installation, this device must be mounted in a suitable dust tight end-enclosure and must be wired using Division 2 wiring methods as specified in article 501-4 (b), 502-4 (b), and 503-3 (b) of the National Electrical Code, NFPA 70 for installation within the United States, or as specified in section 19-152 of Canadian Electrical Code for installation in Canada.

PANEL CUT-OUT

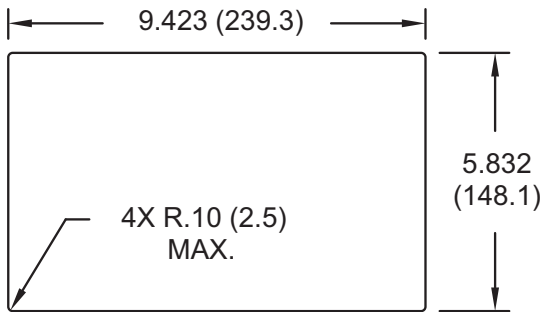

All tolerances ± 0.059 " (± 1.5 mm)

VESA MOUNT (MIS-D 75) DIMENSIONS

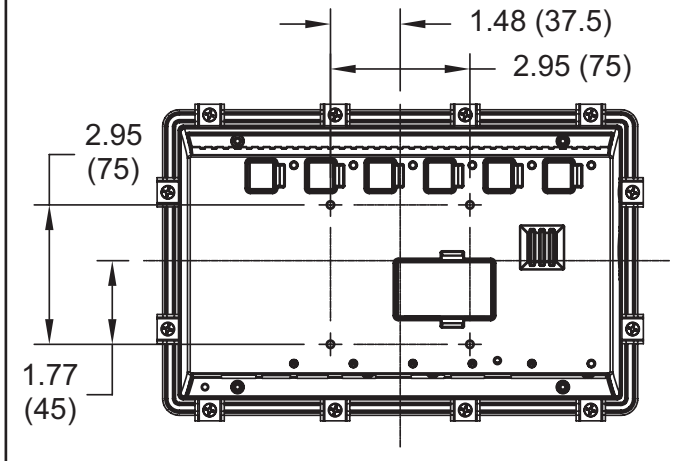

CONNECTING TO EARTH GROUND



The protective conductor terminal is bonded to conductive parts of the equipment for safety purposes and must be connected to an external protective earthing system.

Each operator panel has a chassis ground terminal on the back of the unit. Your unit should be connected to earth ground (protective earth).

The chassis ground is not connected to signal common of the unit. Maintaining isolation between earth ground and signal common is not required to operate your unit. But, other equipment connected to this unit may require isolation between signal common and earth ground. *To maintain isolation between signal common and earth ground care must be taken when connections are made to the unit.* For example, a power supply with isolation between its signal common and earth ground must be used. Also, plugging in a USB cable may connect signal common and earth ground.¹

¹ USB's shield may be connected to earth ground at the host. USB's shield in turn may also be connected to signal common.

POWER SUPPLY REQUIREMENTS

The G09 requires a 24 VDC power supply. Your unit may draw considerably less than the maximum rated power depending upon the features being used. As additional features are used your unit will draw increasing amounts of power. Items that could cause increases in current are modules, additional on-board communications, SD card, and other features programmed through Crimson.

In any case, it is very important that the power supply is mounted correctly if the unit is to operate reliably. Please take care to observe the following points:

- The power supply must be mounted close to the unit, with usually not more than 6 feet (1.8 m) of cable between the supply and the operator interface. Ideally, the shortest length possible should be used.
- The wire used to connect the operator interface's power supply should be at least 22-gage wire suitably rated for the temperatures of the environment to which it is being installed. If a longer cable run is used, a heavier gage wire should be used. The routing of the cable should be kept away from large contactors, inverters, and other devices which may generate significant electrical noise.
- A power supply with an NEC Class 2 or Limited Power Source (LPS) and SELV rating is to be used. This type of power supply provides isolation to accessible circuits from hazardous voltage levels generated by a mains power supply due to single faults. SELV is an acronym for "safety extra-low voltage." Safety extra-low voltage circuits shall exhibit voltages safe to touch both under normal operating conditions and after a single fault, such as a breakdown of a layer of basic insulation or after the failure of a single component has occurred. A suitable disconnect device shall be provided by the end user.

I/O MODULE INSTALLATION

Modules must be installed beginning with slot 1 (left-most slot), with no empty slots between the modules, and the order must match the modules order in the Crimson database. Torque screws to 6.0 pound-force inch (96 ounce-force inch).

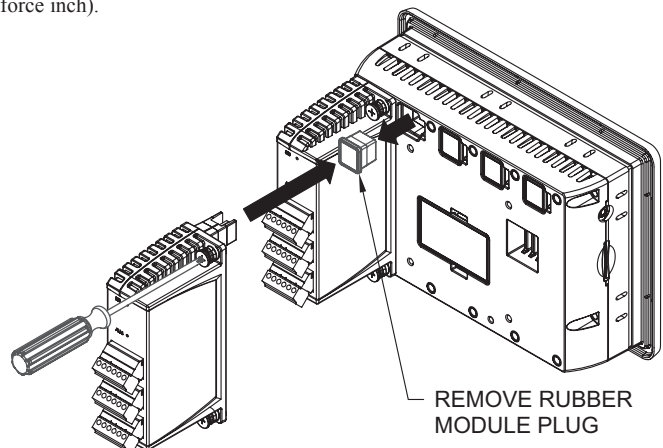

REMOVE RUBBER MODULE PLUG



WARNING: Disconnect all power to the unit before installing or removing modules.

COMMUNICATING WITH THE G09

CONFIGURING A G09

The G09 is configured using Crimson[®] software. Crimson is available as a free download from Red Lion's website. Updates to Crimson for new features and drivers are posted on the website as they become available. By configuring the G09 using the latest version of Crimson, you are assured that your unit has the most up to date feature set. Crimson[®] software can configure the G09 through the RS232 PGM port, USB port, or SD.

The USB port is connected using a standard USB cable with a Type B connector. The driver needed to use the USB port will be installed with Crimson.

The RS232 PGM port uses a programming cable made by Red Lion to connect to the DB9 COM port of your computer. If you choose to make your own cable, use the "G09 Port Pin Out Diagram" for wiring information.

The SD can be used to program a G09 by placing a configuration file and firmware on the SD card. The card is then inserted into the target G09 and powered. Refer to the Crimson literature for more information on the proper names and locations of the files.

INSERTION/REMOVAL OF THE SD CARD

Insert the SD card into the slot provided with the card oriented as shown. The card is inserted properly when the end of the card is flush with the Graphite case. To remove the SD card, push in slightly on the card.

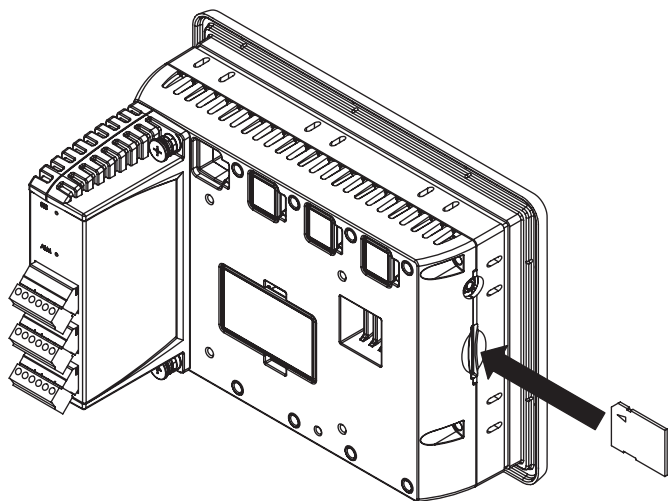

USB, DATA TRANSFERS FROM THE SD CARD



WARNING - DO NOT CONNECT OR DISCONNECT CABLES WHILE POWER IS APPLIED UNLESS AREA IS KNOWN TO BE NON-HAZARDOUS. USB PORT IS FOR SYSTEM SET-UP AND DIAGNOSTICS AND IS NOT INTENDED FOR PERMANENT CONNECTION.

In order to transfer data from the SD card via the USB port, a driver must be installed on your computer. This driver is installed with Crimson and is located in the folder C:\Program Files\Red Lion Controls\Crimson 3.0\Device\ after Crimson is installed. This may have already been accomplished if your G09 was configured using the USB port.

Once the driver is installed, connect the G09 to your PC with a USB cable, and follow "Mounting the SD" instructions in the Crimson 3 user manual.

G09 PORT PIN OUTS

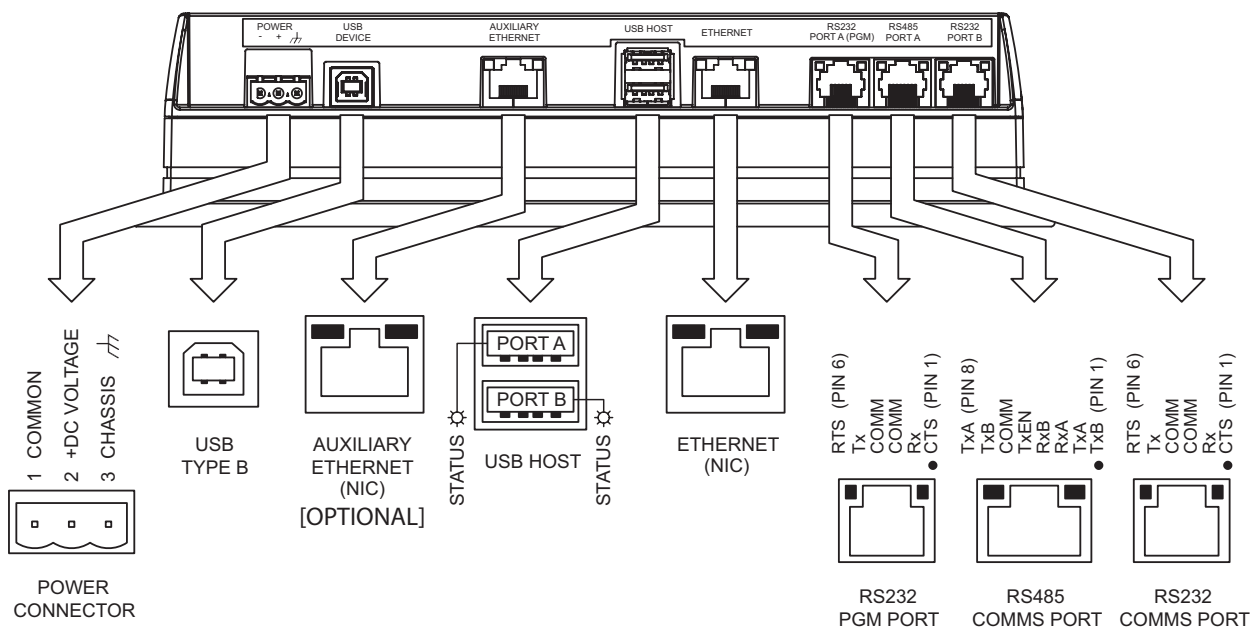

BATTERY & TIME KEEPING



WARNING - EXPLOSION HAZARD - DISCONNECT POWER AND ENSURE THE AREA IS KNOWN TO BE NON-HAZARDOUS BEFORE SERVICING/ REPLACING THE UNIT AND BEFORE INSTALLING OR REMOVING I/O WIRING AND BATTERY.

A battery is used to keep time when the unit is without power. Typical accuracy (at 25°C) of the Graphite time keeping is less than one minute per month drift. The battery of a Graphite unit does not affect the unit's memory, all configurations and data is stored in non-volatile memory.

Changing the Battery

To change the battery of a Graphite, first remove power to the unit. Remove the battery cover. Grasp the top edge of the battery and push to the left to remove the battery from the holder. Lift the battery out and replace with a new battery.

Replace the battery cover, and re-apply power. Using Crimson or the unit's keypad, enter the correct time and date.

** Please note that the old battery must be disposed of in a manner that complies with your local waste regulations. The battery must not be disposed of in fire, or in a manner whereby it may be damaged and its contents could come into contact with human skin.*

The battery used by the panel is a lithium type BR2032.

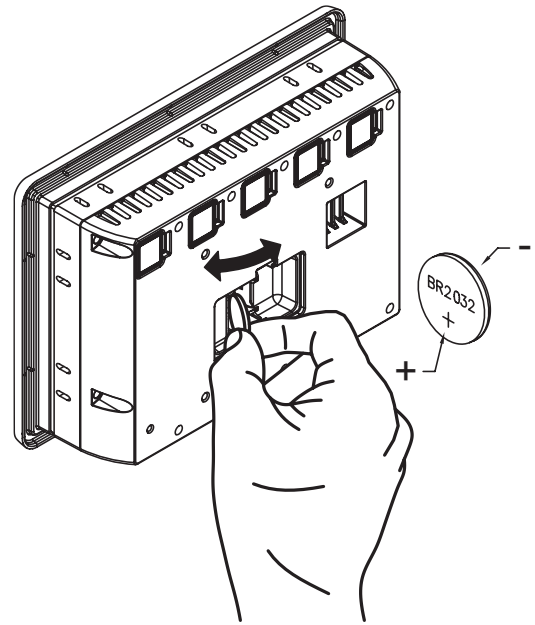

LIMITED WARRANTY

The Company warrants the products it manufactures against defects in materials and workmanship for a period limited to two years from the date of shipment, provided the products have been stored, handled, installed, and used under proper conditions. The Company's liability under this limited warranty shall extend only to the repair or replacement of a defective product, at The Company's option. The Company disclaims all liability for any affirmation, promise or representation with respect to the products.

The customer agrees to hold Red Lion Controls harmless from, defend, and indemnify RLC against damages, claims, and expenses arising out of subsequent sales of RLC products or products containing components manufactured by RLC and based upon personal injuries, deaths, property damage, lost profits, and other matters which Buyer, its employees, or sub-contractors are or may be to any extent liable, including without limitation penalties imposed by the Consumer Product Safety Act (P.L. 92-573) and liability imposed upon any person pursuant to the Magnuson-Moss Warranty Act (P.L. 93-637), as now in effect or as amended hereafter.

No warranties expressed or implied are created with respect to The Company's products except those expressly contained herein. The Customer acknowledges the disclaimers and limitations contained herein and relies on no other warranties or affirmations.