



Tel +1 (717) 767-6511
 Fax +1 (717) 764-0839
 www.redlion-controls.com

Bulletin No. C48T-C
 Drawing No. LP0394
 Revised 3/01

C48T SERIES - 1/16 DIN TIMERS

MODEL C48TS - SINGLE PRESET

MODEL C48TD - DUAL PRESET

- LCD, 7 SEGMENT, 2 LINE, 6 DIGIT DISPLAY, POSITIVE REFLECTIVE OR NEGATIVE TRANSMISSIVE MODELS WITH RED TOP LINE AND GREEN BOTTOM LINE BACKLIGHTING
- SOLID STATE AND RELAY OUTPUT MODELS
- FIELD REPLACEABLE RELAY OUTPUT BOARDS
- STATUS INDICATORS FOR OUTPUTS
- NEMA 4X/IP65 SEALED FRONT BEZEL
- PROGRAMMABLE USER INPUTS AND FRONT PANEL FUNCTION KEY
- PARAMETER SECURITY VIA PROGRAMMABLE OPERATOR ACCESS PRIVILEGES AND PROTECTED VALUE MENU



- HORIZONTAL OR VERTICAL STACKING OF MULTIPLE UNITS
- 85 to 250 VAC or 18 to 36 VDC/24 VAC POWERED UNITS
- RS485 SERIAL COMMUNICATIONS OPTION
- CHOICE OF NUMERIC DATA ENTRY MODES



UL Recognized Component,
 File # E137808



DESCRIPTION

The Model C48 Timer is available in Single or Dual Preset models. The C48T features a 7 segment, 2 line by 6 digit reflective or backlit LCD display. For the backlit versions, the main display line is red and shows the timer value. The smaller secondary display line is green, and can be used to view the preset values or output time values.

The C48 timer can be configured for a variety of different operating modes to meet most timing application requirements. Twelve timing ranges are available from thousandths of a second to hours and minutes. Decimal Points are used to separate the time units (hours, minutes, seconds). Timing can be cumulative or can reset and start upon each power cycle. "On Delay" or "Off Delay", "Single Shot", "Repetitive auto cycling" modes are all supported.

The Timer can also be configured to Continue or Stop timing upon reaching Preset. The display can be programmed to stop at the preset value (Reset to Zero mode) or zero (Reset to Preset mode), or automatically reset to zero or preset and hold. Once stopped, the timer can be restarted by manually resetting it, or it can be programmed to restart when power is reapplied.

The C48 Timer has a Run/Stop Input, 3 programmable User Inputs, and a programmable front panel function key. The Run/Stop and User Inputs can be configured as sinking (active low) or sourcing (active high) inputs via a single plug jumper. The user inputs and the front panel function key can be configured to provide a variety of functions.

Four front panel push-buttons are used for programming the operating modes and data values, changing the viewed display, and performing user programmable functions, e.g. reset, etc. The C48T can be configured for one of two numeric data entry methods, digit entry or automatic scrolling. The digit entry method allows for the selection and incrementing of digits individually. The automatic scrolling method allows for the progressive change of one through all digit positions by pressing and holding the "up" or "down" button.

The Dual Preset models are available with solid-state or Relay outputs. The Single Preset model has a solid-state and relay output in parallel. All solid-state outputs are available in a choice of NPN current sinking or PNP current sourcing, open-collector transistor outputs. All relay output boards are field replaceable.

The optional RS-485 serial communication interface provides two-way communication between a C48 and other compatible equipment such as a printer, PLC, HMI, or a host computer. In multipoint applications (up to thirty-two), the address number of each C48 on the line can be programmed from 0 to 99. Data from the C48 can be interrogated or changed, and alarm output(s) may be reset by sending the proper command code via serial communications. PC software, SFC48, allows for easy configuration of controller parameters. These settings can be saved to disk for later use or used for multi-controller down loading. On-line help is provided within the software.

The unit is constructed of a lightweight, high impact plastic case with a textured front panel and a clear display window. The front panel meets NEMA 4X/IP65 specifications when properly installed. Multiple units can be stacked horizontally or vertically. Modern surface-mount technology, extensive testing, plus high immunity to noise interference makes the C48 Timers extremely reliable in industrial environments.

SAFETY SUMMARY

All safety related regulations, local codes and instructions that appear in the manual or on equipment must be observed to ensure personal safety and to prevent damage to either the instrument or equipment connected to it. If equipment is used in a manner not specified by the manufacturer, the protection provided by the equipment may be impaired.

Do not use this unit to directly command motors, valves, or other actuators not equipped with safeguards. To do so, can be potentially harmful to persons or equipment in the event of a fault to the unit.

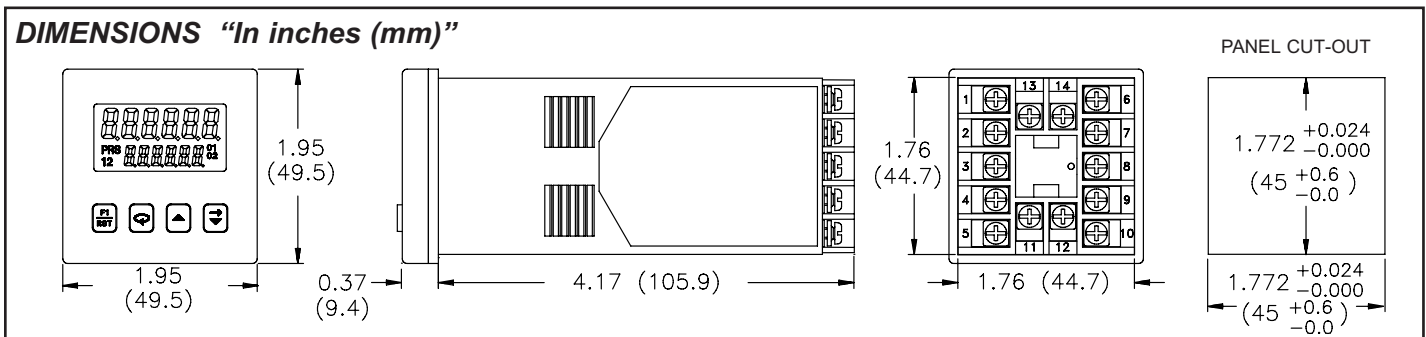

SPECIFICATIONS

1. **DISPLAY:** 2 Line by 6 digit LCD display; Positive image reflective or negative image transmissive with red (top line) and green (bottom line) backlighting.

Main Display: 0.3" (7.62 mm) high digits

Secondary Display: 0.2" (5.08 mm) high digits

Annunciators:

Value: PRS, 1, and 2

Output: 01 and 02

2. **POWER REQUIREMENTS:**

AC Versions (C48CXXX0X):

AC Power: 85 to 250 VAC, 50/60 Hz, 9 VA max.

DC Power: 11 to 14 VDC @ 150 mA max. (Non PNP output models)

Note: Models with PNP current sourcing outputs must be powered from AC.

DC Versions (C48CXXX1X):

CONTINUOUS:

DC Power: 18 to 36 VDC; 5.5 W max.

AC Power: 24 VAC $\pm 10\%$; 50/60 Hz; 7 VA max.

Note: The +10% tolerance range on AC input voltage must be strictly adhered to. DO NOT EXCEED 26.4 VAC.

PEAK (START-UP CURRENT):

AC or DC Power: 500 mA peak start-up current for 10 msec max.

DC OUT (V_{SRC} IN) - Terminal 10

For units which do not have PNP current sourcing outputs, this terminal provides a DC output for sensor power (+12 VDC $\pm 15\%$). The maximum sensor current is 100 mA.

For units with PNP current sourcing outputs, this terminal serves a dual purpose depending on the application's PNP output voltage level and current requirements.

1. The terminal may be used as a +12 VDC output for sensor power. In this case, the PNP output voltage level will be +12 VDC ($\pm 15\%$). A maximum of 100 mA is available for the combination of sensor current and PNP output sourcing current.

2. If a higher PNP output voltage level or additional output sourcing current is desired, an external DC supply may be connected between the "DC OUT (V_{SRC} IN)" and "COMM." terminals. This supply will determine the PNP output voltage level, and must be in the range of +13 to +30 VDC.

An external DC supply can also provide the additional output sourcing current required in applications where two or more PNP outputs are "ON" simultaneously. However, the maximum current rating of 100 mA per individual output must not be exceeded, regardless of external supply capacity.

3. **MEMORY:** Nonvolatile E²PROM retains all programmable parameters and timer values.

4. **SENSOR POWER:** +12 VDC ($\pm 15\%$) @ 100 mA max.

5. **INPUTS:** Run/Stop, U_{sr} In1, U_{sr} In2, and U_{sr} In3.

Configurable as current sinking (active low) or current sourcing (active high) inputs via a single plug jumper.

Current Sinking (active low): V_{IL} = 1.5 VDC max, 22 K Ω pull-up to 5 VDC.

Current Sourcing (active high): V_{IH} = 3.5 VDC min., V_{IN} max = 30 VDC; 22 K Ω pull-down.

Run/Stop Response Time: 250 μ sec max.

User Input Response Time: 5 msec max.

6. **TIME ACCURACY:** $\pm 0.01\%$

7. **OUTPUTS:** (Output type and quantity are model dependent)

Solid-State:

NPN Open Collector: I_{SNK} = 100 mA max. @ V_{OL} = 1.1 VDC max; V_{OH} = 30 VDC max.

PNP Open Collector: I_{SRC} = 100 mA max. (See note); V_{OH} = 12 VDC $\pm 15\%$ (using internal supply); V_{OH} = 13 to 30 VDC (using external supply).

Note: The internal supply of the C48T can provide a total of 100 mA for the combination of sensor current and PNP output sourcing current. The supply voltage is +12 VDC ($\pm 15\%$), which will be the PNP output voltage level when using only the internal supply.

If additional PNP output sourcing current or a higher output voltage level is desired, an external DC supply may be connected between the "DC Out/In" and "Comm." terminals. This supply will determine the PNP output voltage level, and must be in the range of +13 to +30 VDC.

An external supply can provide the additional output sourcing current required in applications where two or more outputs are "ON" simultaneously. However, the maximum rating of 100 mA per individual output must not be exceeded, regardless of external supply capacity.

Relay: Form A contact, Rating = 5 A @ 250 VAC, 30 VDC (resistive load), 1/10 HP @ 120 VAC (inductive load)

Relay Life Expectancy: 100,000 cycles min. at max. load rating

Programmable Timed Output(s): User selectable output time resolution

0.01 Second Resolution: 0.01 to 99.99 seconds, $\pm 0.01\% + 10$ msec max.

0.1 Second Resolution: 0.1 to 999.9 Seconds, $\pm 0.01\% + 100$ msec max.

8. **RS485 SERIAL COMMUNICATIONS (Optional):** Up to 32 units can be connected.

Baud Rate: Programmable from 1200 to 9600 baud

Address: Programmable from 0 to 99

Data Format: 10 Bit Frame, 1 start bit, 7 or 8 data bits, 1 or No Parity bit, and 1 stop bit

Parity: Programmable for Odd (7 data bits), Even (7 data bits), or None (8 data bits)

9. **CERTIFICATIONS AND COMPLIANCES:**

UL Recognized Component, File #E137808

Recognized to U.S. and Canadian requirements under the Component Recognition Program of Underwriters Laboratories, Inc.

ELECTROMAGNETIC COMPATIBILITY

Immunity to EN 50082-2

Electrostatic discharge	EN 61000-4-2	Level 2; 4 Kv contact Level 3; 8 Kv air
Electromagnetic RF fields	EN 61000-4-3	Level 3; 10 V/m 80 MHz - 1 GHz
Fast transients (burst)	EN 61000-4-4	Level 4; 2 Kv I/O Level 3; 2 Kv power
RF conducted interference	EN 61000-4-6	Level 3; 10 V/rms 150 KHz - 80 MHz
Simulation of cordless telephone	ENV50204	Level 3; 10 V/m 900 MHz ± 5 MHz 200 Hz, 50% duty cycle

Emissions to EN 50081-2

RF interference	EN 55011	Enclosure class A
-----------------	----------	-------------------

Notes:

AC VERSIONS

1. A power line filter, RLC#LFIL0000 or equivalent, was installed when the unit was DC powered.

DC VERSIONS

To insure compliance with the EMC standards listed above, do not connect any wires from the terminal(s) labeled "COMM." to the "DC-" supply terminal (12), when powering the unit from a DC supply.

Refer to EMC Installation Guidelines section of the manual for additional information.

10. **ENVIRONMENTAL CONDITIONS:**

Operating Temperature: 0°C to 50°C

Storage Temperature: -40°C to 70°C

Operating and Storage Humidity: 85% max. relative humidity (non-condensing) from 0°C to 50°C.

Altitude: Up to 2000 meters

11. **ELECTRICAL CONNECTION:** Wire clamping screw terminals.

12. **CONSTRUCTION:** Black plastic case with collar style panel latch. The panel latch can be installed for horizontal or vertical stacking. Black plastic textured bezel with clear display viewing window. Unit assembly with circuit boards can be removed from the case without removing the case from the panel or disconnecting the wiring. This unit is rated for NEMA 4X/IP65 indoor use. Installation Category II, Pollution Degree 2.

13. **WEIGHT:** 6.0 oz. (170 g)

SINGLE PRESET MODELS

The C48TS offers a choice of twelve timing ranges with eighteen different operating modes. The unit has a solid-state output that operates in parallel with a relay output. The solid-state output is available as an NPN or PNP open collector transistor.

DUAL PRESET MODELS

The C48TD offers a choice of twelve timing ranges with 42 operating modes. The unit is available with solid-state or relay outputs. The solid-state outputs are available as NPN or PNP open collector transistors.

FRONT PANEL FEATURES

The C48 Timer features a dual line display. In the normal operating mode (main display), the timer value is shown on the top line and preset or output time values are shown on the bottom line. The Presets or Output time values can be programmed to be viewable only, viewable and changeable, or locked (not viewable) from the main display.

In the normal operating mode, the presets and output time values are accessible providing that these values are not programmed for 'Locked'. Values that are accessible (changeable) can be changed immediately when viewed in the secondary display.

VALUE ANNUNCIATORS
Indicate which value is being viewed or modified.

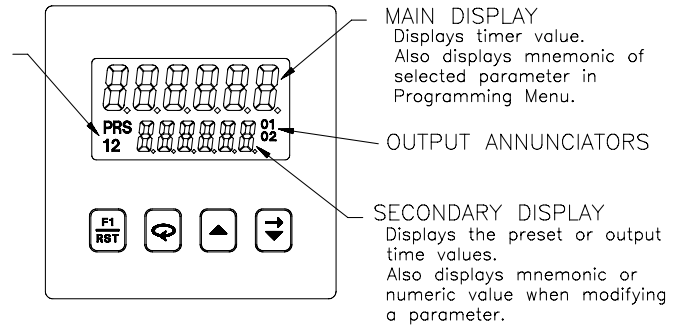

USER INTERFACE/PROGRAMMING MODES

The operating modes of the C48T are programmed using the front panel keypad. To enter the programming menu, the key is pushed and held for 2 seconds. Within the programming menu, the key is used to sequence through the list of programming parameters.

PROGRAMMING MENU

DISPLAY	PARAMETER DESCRIPTION
<i>EnteY</i>	- Digit or Auto Scrolling Data Entry Mode
<i>trAnGE</i>	- Timer Range Modes (See Table on following page)
<i>OPeR</i>	- Timer Operating Modes (See Table on following page)
<i>rStPwP</i>	- Reset at Power up
<i>Rc PrS</i>	- Accessibility of Preset Values
<i>PrESEt</i>	- Preset 1 and 2 Values
<i>P ltrRc</i>	- P1 Track P2 (C48TD only)
<i>Rc Out</i>	- Accessibility of Output Time Values
<i>OutRES</i>	- Output Resolution
<i>OutPut</i>	- Output 1 and 2 Time Values
<i>rEUOut</i>	- Reverse Output/Relay Logic
<i>rEUAnu</i>	- Reverse Output Annunciator Logic
<i>OutPwP</i>	- Power up Output State
<i>USr In 1</i>	- User Input 1
<i>USr In 2</i>	- User Input 2
<i>USr In 3</i>	- User Input 3
<i>USr F1</i>	- User F1 Key
<i>Code</i>	- Programming/Protected Parameter Menu Code
<i>ScroLL</i>	- Scroll Display
<i>SErSEt</i>	- Serial Baud Rate and Parity Settings
<i>SErAdr</i>	- Serial Unit Address
<i>SErAbR</i>	- Abbreviate Serial Mnemonics
<i>PrnOPt</i>	- Print Options
<i>PrnrSt</i>	- Print and Reset Time Value
<i>FRcSEt</i>	- Load Factory Default Settings

(RS485 option only)

FRONT PANEL KEYPAD

- Performs user Programmed Function
- Cycles through secondary displays.
- Enters Programming Mode or Protected Value Menu when pushed and held for 2 seconds.
- Scrolls through programming displays.
- Enters Data Values.
- Selects next available mode in programming mode.
- Increments digit in Digit Entry mode.
- Increments value in Auto Scrolling entry mode.
- Selects Data Entry mode for displayed data values.
- Selects Digit to right when in Digit Entry mode.
- Decrements value in Auto Scrolling entry mode.

Program Security/Operator Accessible Values

The Program Disable Plug Jumper, Programmable Code Value, User Input (programmed for Program Disable), and the Accessible value parameter settings provide various levels of security against unauthorized programming changes. The accessible value parameters provide individual access or locking of each value.

Protected Value Menu

The Protected Value Menu allows access to selected presets and timed output values without having them viewable or changeable from the main display. To enter the protected menu, the key is pressed and held, and a programmed code value is entered.

Timer Range Modes - trAnGE

The timer can be configured to operate in one of 12 time ranges. The table below shows the various ranges available with the time resolution of each range.

MODE	RANGE	RESOLUTION
<i>SEC.000</i>	999.999 Seconds	0.001 sec
<i>SEC.00</i>	9999.99 Seconds	0.01 sec
<i>SEC.0</i>	99999.9 Seconds	0.1 sec
<i>SEC</i>	999999 Seconds	1 sec
<i>n.000</i>	999.999 Minutes	0.001 min
<i>n.00</i>	9999.99 Minutes	0.01 min
<i>n.0</i>	99999.9 Minutes	0.1 min
<i>n.SEC</i>	9999.59 Minutes.Seconds	1 sec
<i>n.SEC.0</i>	999.59.0 Minutes.Seconds.0	0.1 sec
<i>h.n.SEC</i>	99.59.59 Hours.Minutes.Seconds	1 sec
<i>h.n.00</i>	99.59.99 Hours.Minutes.00	0.01 min
<i>h.n.0</i>	999.59.9 Hours.Minutes.0	0.1 min

Programmable Operating Modes - *OPER*

These modes determine the operational characteristics of the timer. In the tables, 01 and 02 refer to Output 1 and Output 2 respectively.

SINGLE PRESET OPERATING MODES	
1 - Manual Reset to Zero, Latched Output	10 - Stop Timer at 01, Manual Reset to Zero, Timed Output
2 - Manual Reset to Zero, Timed Output	11 - Stop Timer at 01, Manual Reset to Preset, Latched Output
3 - Manual Reset to Preset, Latched Output	12 - Stop Timer at 01, Manual Reset to Preset, Timed Output
4 - Manual Reset to Preset, Timed Output	13 - Stop Timer at 01, Auto Reset to Zero, Latched Output
5 - Auto Reset to Zero, Timed Output	14 - Stop Timer at 01, Auto Reset to Zero, Timed Output
6 - Auto Reset to Preset, Timed Output	15 - Stop Timer at 01, Auto Reset to Preset, Latched Output
7 - Auto Reset to Zero at 01 End, Timed Output	16 - Stop Timer at 01, Auto Reset to Preset, Timed Output
8 - Auto Reset to Preset at 01 End, Timed Output	17 - Stop Timer at 01, Auto Reset to Zero at 01 End, Timed Output
9 - Stop Timer at 01, Manual Reset to Zero, Latched Output	18 - Stop Timer at 01, Auto Reset to Preset at 01 End, Timed Output

DUAL PRESET OPERATING MODES	
1 - Manual Reset to Zero, Latched Outputs	22 - Stop Timer at 02, Manual Reset to Zero, 01 off at 02, 02 Latched
2 - Manual Reset to Zero, 01 Timed, 02 Latched	23 - Stop Timer at 02, Manual Reset to Zero, 01 off at 02, 02 Timed
3 - Manual Reset to Zero, 01 and 02 Timed	24 - Stop Timer at 02, Manual Reset to Preset 2, Latched Outputs
4 - Manual Reset to Zero, 01 off at 02, 02 Latched	25 - Stop Timer at 02, Manual Reset to Preset 2, 01 Timed, 02 Latched
5 - Manual Reset to Zero, 01 off at 02, 02 Timed	26 - Stop Timer at 02, Manual Reset to Preset 2, 01 and 02 Timed
6 - Manual Reset to Preset 2, Latched Outputs	27 - Stop Timer at 02, Manual Reset to Preset 2, 01 off at 02, 02 Latched
7 - Manual Reset to Preset 2, 01 Timed, 02 Latched	28 - Stop Timer at 02, Manual Reset to Preset 2, 01 off at 02, 02 Timed
8 - Manual Reset to Preset 2, 01 and 02 Timed	29 - Stop Timer at 02, Auto Reset to Zero, Latched Outputs
9 - Manual Reset to Preset 2, 01 off at 02, 02 Latched	30 - Stop Timer at 02, Auto Reset to Zero, 01 Timed, 02 Latched
10 - Manual Reset to Preset 2, 01 off at 02, 02 Timed	31 - Stop Timer at 02, Auto Reset to Zero, 01 and 02 Timed
11 - Auto Reset to Zero, 01 and 02 Timed	32 - Stop Timer at 02, Auto Reset to Zero, 01 off at 02, 02 Latched
12 - Auto Reset to Zero, 01 off at 02, 02 Timed	33 - Stop Timer at 02, Auto Reset to Zero, 01 off at 02, 02 Timed
13 - Auto Reset to Preset 2, 01 and 02 Timed	34 - Stop Timer at 02, Auto Reset to Preset 2, Latched Outputs
14 - Auto Reset to Preset 2, 01 off at 02, 02 Timed	35 - Stop Timer at 02, Auto Reset to Preset 2, 01 Timed, 02 Latched
15 - Auto Reset to Zero at 02 End, 01 and 02 Timed	36 - Stop Timer at 02, Auto Reset to Preset 2, 01 and 02 Timed
16 - Auto Reset to Zero at 02 End, 01 off at 02, 02 Timed	37 - Stop Timer at 02, Auto Reset to Preset 2, 01 off at 02, 02 Latched
17 - Auto Reset to Preset 2 at 02 End, 01 and 02 Timed	38 - Stop Timer at 02, Auto Reset to Preset 2, 01 off at 02, 02 Timed
18 - Auto Reset to Preset 2 at 02 End, 01 off at 02, 02 Timed	39 - Stop Timer at 02, Auto Reset to Zero at 02 End, 01 and 02 Timed
19 - Stop Timer at 02, Manual Reset to Zero, Latched Outputs	40 - Stop Timer at 02, Auto Reset to Zero at 02 End, 01 off at 02, 02 Timed
20 - Stop Timer at 02, Manual Reset to Zero, 01 Timed, 02 Latched	41 - Stop Timer at 02, Auto Reset to Preset 2 at 02 End, 01 and 02 Timed
21 - Stop Timer at 02, Manual Reset to Zero, 01 and 02 Timed	42 - Stop Timer at 02, Auto Reset to Preset 2 at 02 End, 01 off at 02, 02 Timed

MULTIPLE UNIT STACKING

The C48T is designed for close spacing of multiple units. Units can be stacked either horizontally or vertically. For vertical stacking, install the panel latch with the screws to the sides of the unit. For horizontal stacking, the panel latch screws should be at the top and bottom of the unit. The minimum spacing

from center line to center line of the units is 1.96" (49.8 mm). This spacing is the same for vertical or horizontal stacking.

Note: When stacking units, provide adequate panel ventilation to ensure that the maximum operating temperature range is not exceeded.

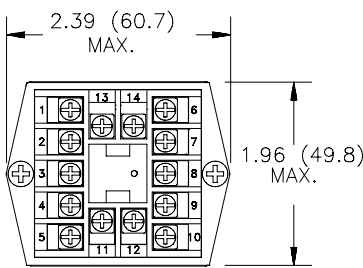

PANEL LATCH INSTALLED FOR VERTICAL UNIT STACKING

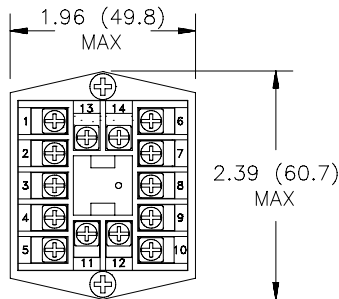

PANEL LATCH INSTALLED FOR HORIZONTAL UNIT STACKING

PANEL CUT-OUT SPACING FOR MULTIPLE UNIT STACKING. HORIZONTAL ARRANGEMENT SHOWN.

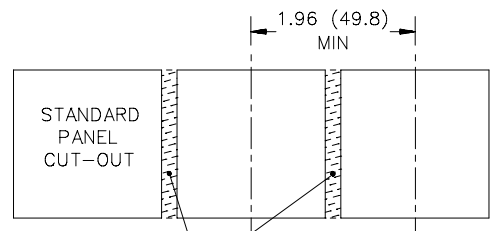

IF NEMA 4 IS NOT REQUIRED, THIS PANEL MATERIAL MAY BE REMOVED.

APPLICATION

ONE SHOT TIMING CYCLE

Proper wash down mixture for a food processing plant is an important factor in maintaining the clean environment required. A disinfectant solution is added to the mixing/holding tank used for the wash down cycle. When the holding tank is near empty, a level transducer activates the filler pump. A C48TS is used to turn on the disinfectant solution pump for a preprogrammed amount of time during the filling process of the holding tank.

When the filler pump starts, a momentary contact closure activates User Input 1, resetting the C48 Timer. The timer begins the timing cycle since the

run terminal is connected to common. The normally open relay contacts close at the timer reset signal activating the disinfectant solution pump. When the programmed preset is reached, timing stops and the relay deactivates, turning off the pump controlling the disinfectant solution. The C48 Timer's preset cycle time may be changed according to the manufacturer's concentration level of the disinfectant.

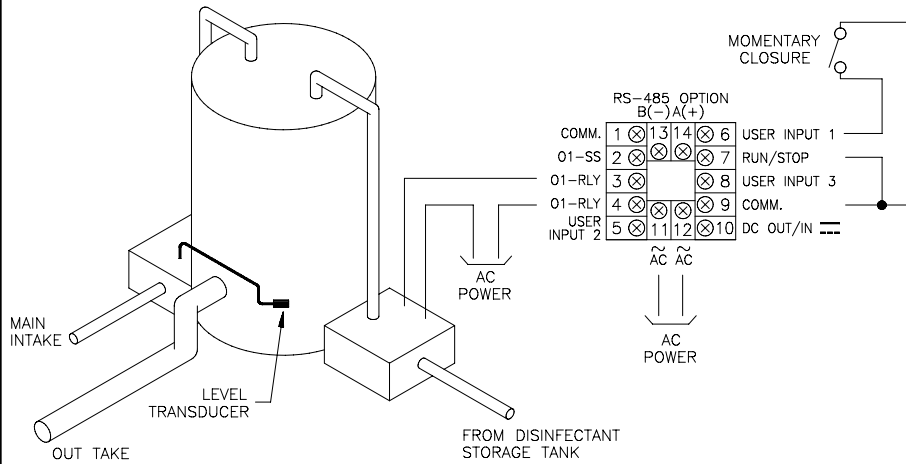

PROGRAMMING

Entry **Auto Sc**
ErAnGE **nSE** (min & sec)
OPER **09**
rStPμP **no**
Ac PrS **-Y** (yes)
PrESEt **XXXX.XX**
rEUOut **-Y** (yes)
rEUAnu **-n** (no)
OutPμP **-F** (off)
USr In 1 **rSt-E**
USr In 2 **Prad iS**
USr In 3 **Enh dSP**
USr F 1 **rSt-E**
Code **XXXX**
ScroLL **no**

ORDERING INFORMATION

MODEL NO.	DESCRIPTION	* NPN O.C. OUTPUT(S)	RELAY OUTPUT(S)	RS485	PART NUMBERS FOR AVAILABLE SUPPLY VOLTAGES	
					18-36 VDC/24VAC	85 to 250 VAC
C48T	1 Preset Timer, Reflective LCD	Yes	Yes	No	C48TS013	C48TS003
	1 Preset Timer, Backlit LCD	Yes	Yes	No	C48TS113	C48TS103
	2 Preset Timer, Reflective LCD	No	Yes	No	C48TD012	C48TD002
	2 Preset Timer, Reflective LCD	No	Yes	Yes	C48TD017	C48TD007
	2 Preset Timer, Reflective LCD	Yes	No	Yes	N/A	C48TD005
	2 Preset Timer, Backlit LCD	No	Yes	No	C48TD112	C48TD102
	2 Preset Timer, Backlit LCD	No	Yes	Yes	C48TD117	C48TD107
	2 Preset Timer, Backlit LCD	Yes	No	Yes	N/A	C48TD105

* PNP O.C. output(s) versions are available, contact the factory.

RELAY OUTPUT BOARDS

MODEL NO.	DESCRIPTION	NPN O.C. OUTPUT	PNP O.C. OUTPUT	RELAY OUTPUT(S)	PART NUMBER
RBC48	Single Preset	Yes	No	Yes	RBC48001
	Dual Preset	No	No	Yes	RBC48003

ACCESSORIES

MODEL	DESCRIPTION	PART NUMBER
SFC48	PC Configuration Software for Windows 3.x and 95 (3.5"disk) (for RS-485 Models)	SFC48