

Panasonic
ideas for life

**DIN24 SIZE
MULTI-RANGE ANALOG TIMER**

**PM5S-A
PM5S-S
PM5S-M**

C-UL File No.: E59504 (Vol. 3)

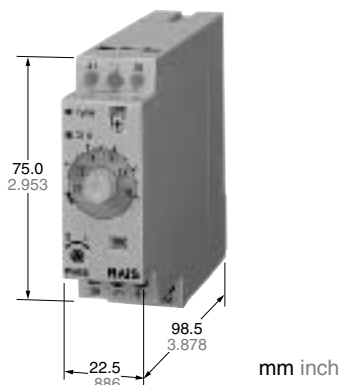

Features

- 24-240V AC/DC free-voltage input
- Built-in Screw terminals
- 6 different operation modes: (PM5S-A)
- Multiple time ranges — 1 s to 500 h (Max.)
- Slim body — DIN 22.5 mm .886 inch
- 0 setting instantaneous output operation
- UL/C-UL/CE approval

Product types

Type	Operation mode	Contact arrangement	Time range	Protective construction	Rated operating voltage	Part number
PM5S-A	6 operation modes • Pulse ON-delay • Pulse Flicker • Pulse ON-flicker • Signal OFF-delay • Pulse One-shot • Pulse One-cycle	Relay Timed-out 2 Form C	16 selectable ranges 1s to 500h	IP40	24 to 240V AC/DC	PM5S-A-24-240V
PM5S-S	Power ON-delay	Relay Timed-out 2 Form C				PM5S-S-24-240V
PM5S-M	6 operation modes (With instantaneous contact) • Pulse ON-delay • Pulse Flicker • Pulse ON-flicker • Signal OFF-delay • Pulse One-shot • Pulse One-cycle	Relay Timed-out 1 Form C Instantaneous 1 Form C				PM5S-M-24-240V

Time range

Scale	Time unit				
	sec	min	hrs	10h	
1	Control time range	0.1s to 1s	0.1 min to 1 min	0.1h to 1h	1.0h to 10h
5		0.5s to 5s	0.5 min to 5 min	0.5h to 5h	5h to 50h
10		1.0s to 10s	1.0 min to 10 min	1.0h to 10h	10h to 100h
50		5s to 50s	5 min to 50 min	5h to 50h	50h to 500h

Note: 0 setting is for instantaneous output operation.

PM5S-A/PM5S-S/PM5S-M

All types of PM5S timer have multi-time range.

16 time ranges are selectable.

1s to 500h (Max. range) is controlled.

CHARACTERISTICS

Item	Type	PM5S-A	PM5S-S	PM5S-M
Rating	Rated operating voltage	24 to 240V AC/DC		
	Rated frequency	50/60Hz common		
	Rated power consumption	2.6 VA (AC), 1.4 W (DC)		
	Output rating	5A 250V AC (resistive load)		
	Operating mode	Pulse ON-delay Pulse Flicker Pulse ON-Flicker Signal OFF-delay Pulse One-shot Pulse One-cycle	Power ON-delay	Pulse ON-delay Pulse Flicker Pulse ON-flicker Signal OFF-delay Pulse One-shot Pulse One-cycle (with instantaneous contact)
Time accuracy (Note:)	Time range	1s to 500h (Max.) 16 time ranges switchable		
	Operating time fluctuation	±0.3% (power off time change at the range of 0.1s to 1h)		
	Setting error	±10% (Full-scale value)		
	Voltage error	±0.5% (at the operating voltage changes between 85 to 110%)		
Contact	Temperature error	±2% (at 20°C ambient temp. at the range of -10 to +55°C +14 to +131°F)		
	Contact arrangement	Timed-out 2 Form C	Timed-out 1 Form C Instantaneous 1 Form C	
	Contact resistance (Initial value)	Max. 100mΩ (at 1A 6V DC)		
Life	Contact material	Silver alloy	Au flash on Silver alloy	
	Mechanical (contact)	2×10 ⁷	1×10 ⁷	
Electrical function	Electrical (contact)	10 ⁵ (at rated control capacity)		
	Allowable operating voltage range	85 to 110% of rated operating voltage (at 20°C coil temp.)		
	Insulation resistance (Initial value)	Min. 100MΩ	Between live and dead metal parts Between input and output Between contacts of different poles Between contacts of same pole (At 500V DC)	
	Breakdown voltage (Initial value)	2,000Vrms for 1 min Between live and dead metal parts 2,000Vrms for 1 min Between input and output 2,000Vrms for 1 min Between contacts of different poles 1,000Vrms for 1 min Between contacts of same pole		
	Min. power off time	100ms		
Mechanical function	Max. temperature rise	55°C 131°F	65°C 149°F	
	Shock resistance	Functional	Min. 98m/s ² (4 times on 3 axes)	
		Destructive	Min. 980m/s ² (5 times on 3 axes)	
	Vibration resistance	Functional	10 to 55Hz: 1 cycle/min Single amplitude of 0.35mm (10min on 3 axes)	
Destructive		10 to 55Hz: 1 cycle/min Single amplitude of 0.75mm (1h on 3 axes)		
Operating condition	Ambient temperature	-10 to +55°C +14 to +131°F		
	Ambient humidity	Max. 85%RH		
	Atmospheric pressure	860 to 1,060hPa		
	Ripple factor (DC)	20%		
Others	Protective construction	IP40		
	Weight	120g 4.233 oz		

Note: 1) Unless otherwise specified, the measurement conditions at the maximum scale time standard are specified to be the rated operating voltage (within 5% ripple factor for DC), 20°C 68°F ambient temperature, and 1s power off time.
 2) For the 1s range, the tolerance for each specification becomes ±10ms.

WIRING DIAGRAMS

PM5S-A

- Timed-out 2 Form C

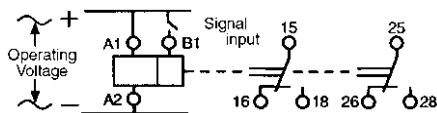

PM5S-S

- Timed-out 2 Form C

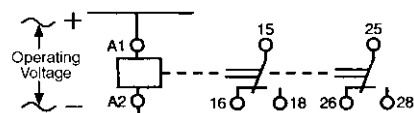

PM5S-M

- Timed-out 1 Form C
- Instantaneous 1 Form C

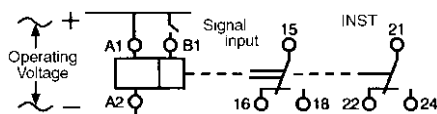

Contact

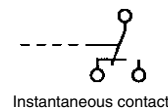
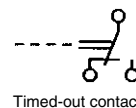

MODE SELECTION

PM5S-A/M type

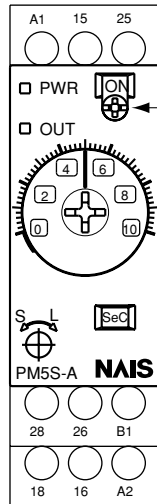

- Operation mode indicator
 Selectable from 8 operation modes
 ON: ON-delay
 FL: Flicker
 FO: ON-flicker
 SF: Signal OFF-delay
 OS: Pulse One-shot
 OC: Pulse One-cycle

The 6 operation modes of PM5S-A and PM5S-M can be selected by the operation mode selector switch. In the next pages the different modes will be explained.

DIMENSIONS

PM5S-□

mm inch

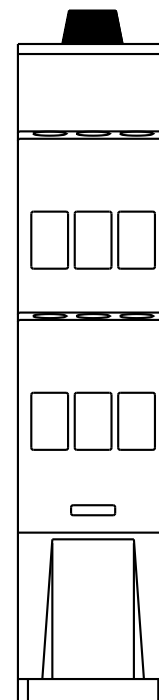
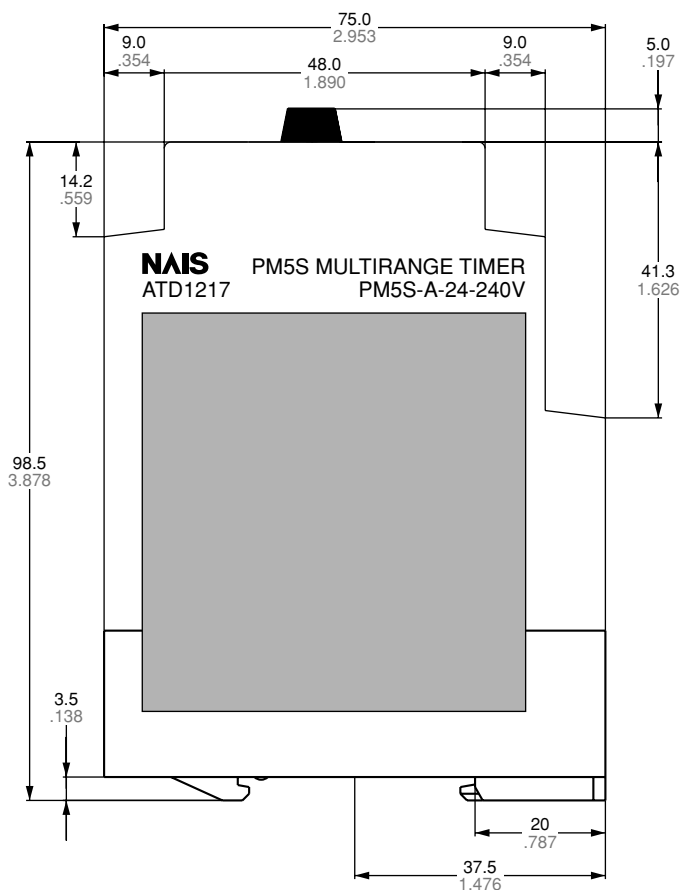
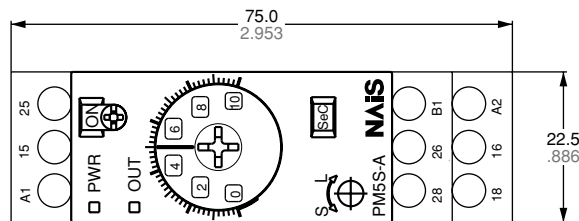

OPERATION MODE

PM5S-A/M

(* LED lighting ✱ LED flickering
T: Setting time $t_1, t_2 < T$

Operation mode	Operation	Time chart
<p>ON-delay</p> <p>ON</p>	<p>Turn the operation selector to ON.</p> <p>Timing operation starts when terminals A1 – B1 are connected while power is on. Control output is turned on after the set time regardless of duration of operation signal</p>	
<p>Flicker</p> <p>FL</p>	<p>Turn the operation selector to FL.</p> <p>Timing operation starts when terminals A1 – B1 are connected while power is on. Control output repeatedly turn OFF and ON regardless of operation signal input time.</p>	
<p>ON-flicker</p> <p>FO</p>	<p>Turn the operation selector to FO.</p> <p>Timing operation starts when terminals A1 – B1 are connected while power is on. Control output repeatedly turns ON and OFF regardless of operation signal input time.</p>	
<p>Signal OFF-delay</p> <p>SF</p>	<p>Turn the operation selector to SF.</p> <p>Timing operation starts when terminals A1 – B1 are opened while power is on. Control output is turned off after the set time. If the signal input turns OFF during timing operation, the timing operation starts at that point again.</p>	
<p>One-shot</p> <p>OS</p>	<p>Turn the operation selector to OS.</p> <p>Timing operation starts when terminals A1 – B1 are connected while power is ON. Control output continues ON state while timing operation.</p>	

Note: Keep 0.1s or more for power off time.
Keep 0.05s or more for signal, input time.

Operation mode	Operation	Time chart
<p>One-cycle</p> <p>OC</p>	<p>Turn the operation selector to OC.</p> <p>Timing operation starts when terminals A1 – B1 are connected while power is ON.</p> <p>Control output is turned on after the set time, the pulse is 0.5 to 1.0 s.</p>	

Note: Keep 0.1s or more for power off time.
Keep 0.05s or more for signal, input time.

OPERATION MODE

PM5S-S

(* LED lighting * LED flickering)
T: Setting time

Operation mode	Operation	Time chart
<p>Power ON-delay</p>	<p>When power is applied continuously, the time cycle begins. The output contacts change state after the time delay is completed.</p>	

MODES & TIME SETTING

1) Operation mode setting [PM4H-A]

6 operation modes are selectable with operation mode selector.

Turn the operation mode selector with screw driver.

Operation mode is shown up through the window above the mode selector. The marks are **ON**, **FL**, **FO**, **SF**, **OS**, **OC**. Turn the mode selector to the mark until you can check by clicking sound.

Confirm the mode selector position if it is correct.

If the position is not stable, the timer might mis-operate.

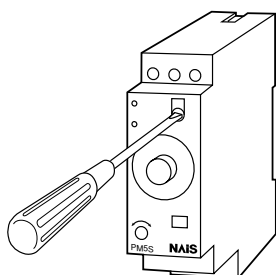

2) Time setting [common]

16 time ranges are selectable between 1s to 500h.

Turn the time range selector with the screw driver.

Clockwise turning increases the time range, and Counter-clockwise turning decrease the time range.

Confirm the range selector position if it is correct.

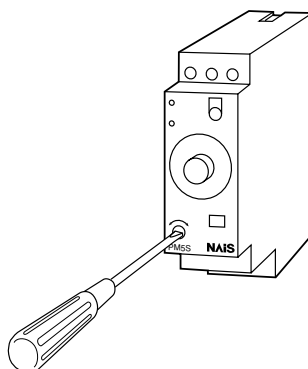

3) Time setting [common]

To set the time, turn the set dial to a desired time within the range. Instantaneous output will be on when the dial is set to "0".

When the instantaneous output is used, the dial should be set under "0" range. (Instantaneous output area)

When power supply is on, the time range, setting time and operation mode cannot be changed.

Turn off the power supply is applied to set the new operation mode.

To set the time in the range, turn the dial to a desired time scale. Do not turn the dial beyond the stopper.

• Cautions for Time setting/Operating mode setting

1) Time chart

- T shots setting time, t1 and t2 means the time in setting time. (t1, t2 < T)
 - When the output relay is turned on, No contact is closed and NC contact is opened.
 - LED indication * shows "Turn ON"
- 2) Timing operation starts when power is applied to terminals A1 – B1
Input signal time should be taken over 0.05 sec.

Short-circuited condition: Max. 1kΩ

Open-circuited condition: Min. 100kΩ

PM5S-A/S/M

INPUT CONNECTIONS

The inputs of the PM5S-A/M are voltage (voltage imposition or open) inputs.

No-contact input

(Connection to PNP output sensor.)

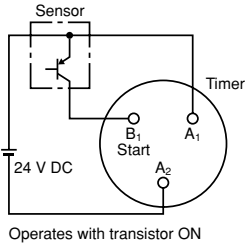

Contact input

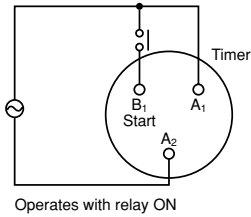

Voltage Input Signal Levels

No-contact input	1. Transistor ON Residual voltage: 1 V max. (Voltage between terminals B ₁ and A ₂ must be more than the rated "H-level" voltage (20.4 V DC min.).)
	2. Transistor OFF Leakage current: 0.01 mA max. (Voltage between terminals B ₁ and A ₂ must be less than the rated "L-level" voltage (2.5 V DC max.).)
Contact input	Use contacts that can adequately switch 0.1 mA at each voltage to be imposed. (When the contacts are ON or OFF, voltage between terminals B ₁ and A ₂ must be within the following ranges: When contacts are ON: 20.4 to 264 V AC/DC When contacts are OFF: 0 to 2.5 V AC/DC

MOUNTING AND DISMOUNTING

The PM5S should be mounted as horizontally as possible. When mounting the PM5S on a socket mounting track, hook portion (A) of the Timer to an edge of the track first, and then depress the Timer in the direction of (B).

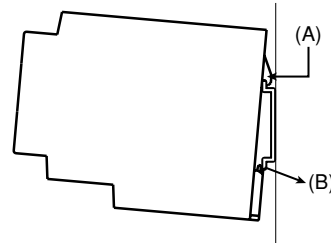

When dismantling the PM5S pull out portion (C) with a flat-blade screwdriver and remove the Timer from the mounting track.

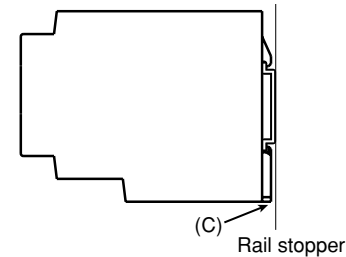

CAUTIONS FOR USE

Cautions

1) Prevent using the timer in such places where flammable or corrosive gas is generated, a lot of dust exists, oil is splashed or considerable shock and vibration occur.

2) Since the body cover is consisted of polycarbonate resin, prevent from contact with organic solvents such as methyl alcohol, benzine and thinner, or strong alkali materials such as ammonia and caustic soda.

POWER SUPPLIES

The PM5S Series is provided with a transformerless power supply system. An electric shock may be received if the input terminal or the output type selector switch is touched while power is being supplied.

Use the bar terminal for wiring the PM5S. Using a stranded-wire terminal may cause a short-circuit due to a stray wire entering into the Timer.

For the power supply of the input device, use a single-phase or double-phase insulated power transformer. The second-phase side must not be grounded.

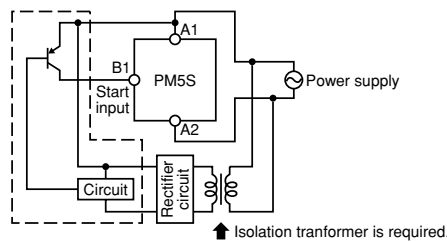

- Input and Power supply circuit (PM5-A/M)
- Since input circuit and power supply circuit is independent, it is possible to switch ON and OFF for input circuit regardless power ON and OFF.

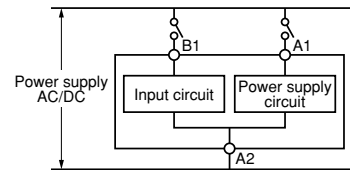

Note that the contact of input circuit is given same voltage as power voltage.

TERMINAL CONNECTIONS

- Refer to the terminal layout and wiring diagram and securely connect the terminals accordingly.
- Do not allow control output to exceed rated control capacity.

1. When one input signal is simultaneously applied to more than one timer, be sure to avoid the wiring shown in Fig. A. Otherwise, the short-circuit current will flow and cause damage. Be sure to align the polarity of the power supply as shown in Fig. B.

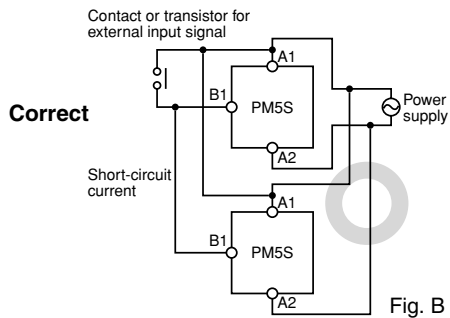
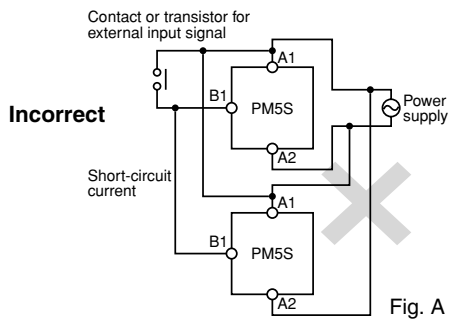

The PM5S series is provided with a transformer less power supply system.

2. External surge protection may be required if the following values are exceeded. Otherwise, the internal circuit will be damaged.

Operating voltage	24 to 240 V AC
Surge voltage	4,000 V

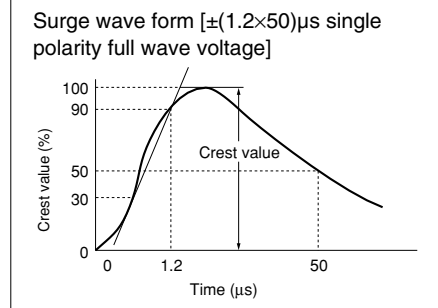

3. For connecting and disconnecting operating voltage to the timer, a circuit should be used to prevent the flow of leakage current. For example, a circuit for contact protection as shown in Fig. C will permit leakage current to flow through R and C, causing erroneous operation of the timer. Instead, the circuit shown in Fig. D should be used.

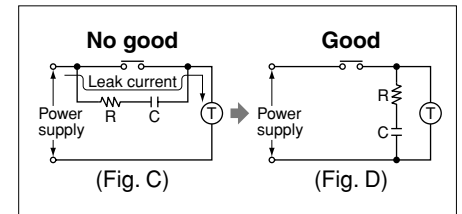

4. In order to maintain the characteristics of the timer, long continuous current flow through the timer, causing generation of heat internally should be avoided because of the degradation it can cause. For such long continuous operation, the circuit shown below should be used.

