

MINAS A6 SERIES

ADDITIONAL TECHNICAL INFORMATION

For Catalog 4247
Servo Drives

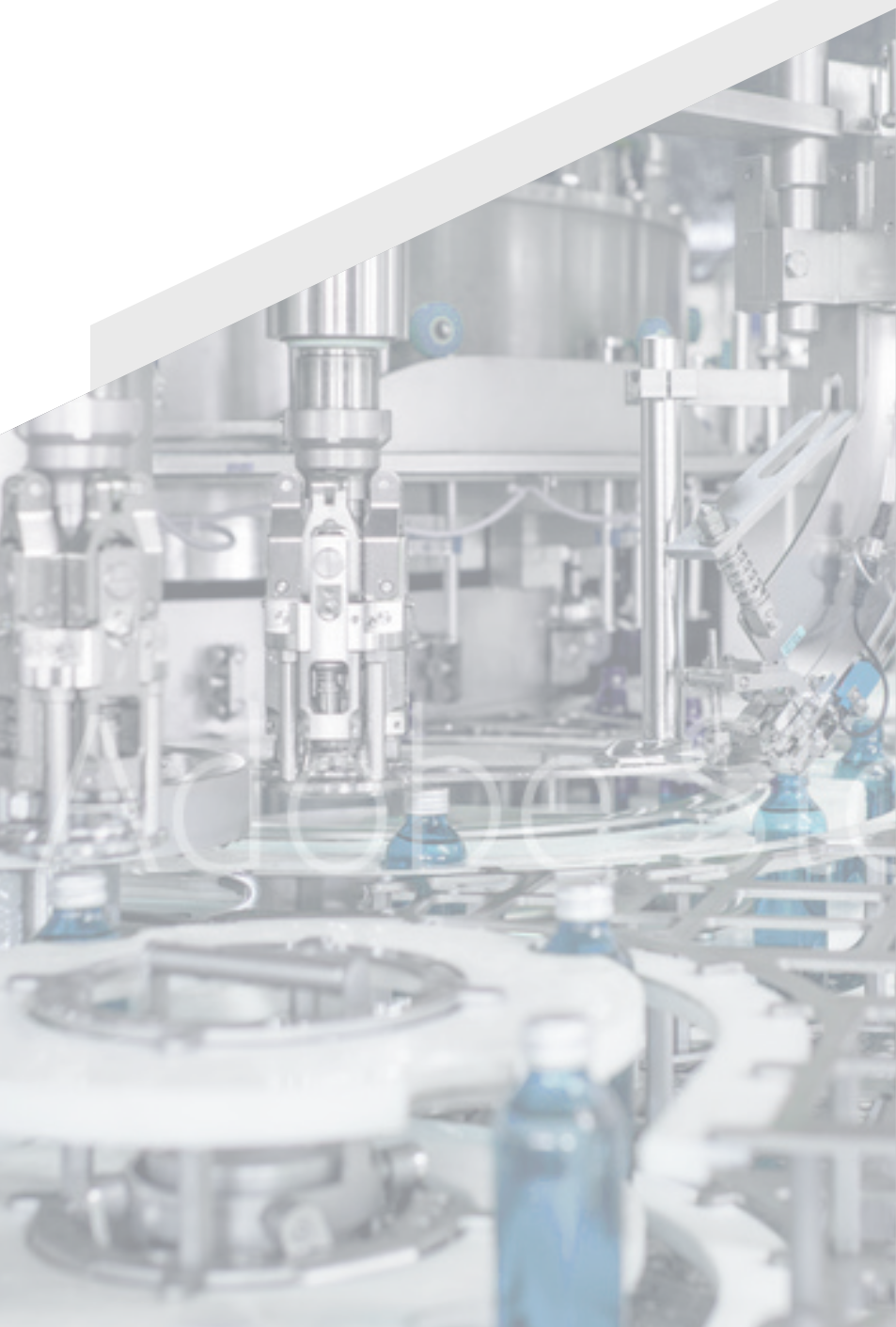

MINAS A6 SERIES – Servo drivers – Specifications	3
Basic specifications 200V AC	3
Functions 200V AC	4
Specifications 400V AC	5
Power supply for servo driver MINAS A6 Multi	6
Servo driver MINAS A6 Multi 400V AC	7
MINAS A6 SERIES – Servo drivers – Frames	8
200/400V AC	8
Power supply for servo driver MINAS A6 Multi	10
Servo driver MINAS A6 Multi 400V AC	10
MINAS A6 SERIES – Servo motors – Specifications	11
200V AC	11
MSMF (low inertia moment) 50–1500W, 200V AC	11
MDMF (medium inertia moment) 1000–1500W, 200V AC	12
MHMF (high inertia moment) 50–1500W, 200V AC	13
400V AC	14
MSMF (low inertia moment) 1kW–5kW, 400V AC	14
MDMF (medium inertia moment) 1kW–5kW, 400V AC	15
MHMF (high inertia moment) 1kW–5kW, 400V AC	16
MINAS A6 SERIES – Servo motors – Torque characteristics	17
200V AC	17
MSMF (low inertia moment), 200V AC	17
MDMF (medium inertia moment), 200V AC	19
MHMF (high inertia moment), 200V AC	20
400V AC	22
MSMF (low inertia moment), 400V AC	22
MDMF (medium inertia moment), 400V AC	23
MHMF (high inertia moment), 400V AC	24
MINAS A6 SERIES – Servo motors – Dimensions	25
200V AC	25
MSMF (low inertia moment) 50–1500W, 200V AC	26
MDMF (medium inertia moment) 1000–1500W, 200V AC	28
MHMF (high inertia moment) 50–1500W, 200V AC	29
400V AC	31
MSMF (low inertia moment) 1kW–5kW, 400V AC	31
MDMF (medium inertia moment) 1kW–5kW, 400V AC	33
MHMF (high inertia moment) 1kW–5kW, 400V AC	35

Basic specifications 200V AC

		Frame	MINAS A6SE, A6SG, A6SF	MINAS A6N	MINAS A6B
Input power	Main circuit	A-D	1-phase, 3-phase, 200-240V (+10%, -15%), 50/60Hz		
		E, F	3-phase, 200-240V (+10%, -15%), 50/60Hz		
	Control circuit	A, B, C, D, E, F	1-phase, 200-240V (+10%, -15%), 50/60Hz		
Operating conditions		Ambient temperature	0-55°C, storage temperature: -20 to +65°C (max. temperature 80°C for 72 h)		
		Ambient humidity	Operation and storage: 20-85% RH (non-condensing)		
		Altitude	Max. 1000m above sea level		
		Vibration	Max. 5.88m/s ² , 10-60Hz (no continuous use at resonance frequency)		
Control method		IGBT sinusoidal PWM			
Encoder		Absolute	23 bit (resolution 8388608ppr)		
		Incremental	23-bit, no battery required, set parameter Pr.015 to 1		
External feedback scale (X5 connector)		A/B phase	Initialization signal differential input (X5 connector only available for A6SF, A6N + A6B)		
		Serial	Compatible with Mitutoyo series AT500, ST771 (X5 connector only available for A6SF, A6N + A6B)		
Control signals (multifunctional)		Inputs	10	8	8
		Output points	6	3	3
Analog signals (A6SF only)		Inputs	3 input points: (16-bit A/D: 1, 12-bit A/D: 2)	-	-
		Output points	2	2	2
Pulse signals		Input points	2 input points (opto coupler, line receiver)	-	-
		Output points	4 output points (line driver: Encoder A, B and Z-phase output or EXA/EXB and EXZ output, Open collector: Z-phase output or EXZ output)	2 output points (line driver: Encoder A-, B-phase output)	
Interface		Realtime Express (RTEX)	-	Available	-
		EtherCAT	-	-	Available
		USB	Interface to PC, etc.		
		RS232	1:1 communication (not for A6SE)	-	-
		RS485	1:n communication with up to 31 axes via host (FP series PLC) (not for A6SE)	-	-
Safety functions		IEC61800-5-2 (SIL3, STO), A6N and A6B also available without safety function			
Front panel		5 buttons (MODE, SET, UP, DOWN, SHIFT), LED (6 digits)		2 rotary switch, LEDs for operation indicator	
Regeneration		For frame A, B: only external braking resistor, for frame C to F: built-in braking resistor (external braking resistor also possible)			
Dynamic brake		For frame A to F: built in			
Control mode		<ul style="list-style-type: none"> › Position control › Velocity control › Torque control › Positioning/velocity control › Positioning/torque control › Rotation speed/torque control, › Full-closed control 	<ul style="list-style-type: none"> › Profile position mode (PP) › Cyclic position mode (CP) › Cyclic velocity mode (CV) › Cyclic torque mode (CT) 	<ul style="list-style-type: none"> › Profile position mode (pp) › Cyclic synchronous position mode (csp) › Homing mode (hm) › Profile velocity mode (pv) › Cyclic synchronous velocity mode (csv) › Torque profile mode (tq) › Cyclic synchronous torque mode (cst) 	

Functions 200V AC

		MINAS A6SE, A6SG, A6SF	MINAS A6N/A6B		
Functions	Position control	Control input	Clear deviation counter, pulse enable, electronic gear switching, damping control switching, etc.	Controller enable, reference signal, measurement value signal, etc.	
		Control output	Position control complete, torque reached, controller status, etc.	Position control complete, torque reached, controller status, etc.	
		Pulse input	Pulse input A	500kpps (opto coupler)	A6N: Via RTEX network (100MBit) A6B: Via EtherCAT network
			Pulse input B	8Mpps (line receiver)	A6N: Via RTEX network (100MBit) A6B: Via EtherCAT network
			Signal format	Differential input/square-wave pulse	A6N: Via RTEX network (100MBit) A6B: Via EtherCAT network
			Electronic gear	Scaling from 1/1000 to 1000 times	
			Smoothing filter	First order low pass filter or FIR filter, customizable	
		Analog input (A6SF only)	Torque limit command	Individual torque limit for positive and negative direction	-
		Instantaneous speed observer	Available		
		Vibration suppression	Manual/automatic		
	Velocity control	Control input	1.-3. Selection of internal velocity setup, 4. Speed clamp, etc.		
		Control output	Set velocity has been reached, etc.	Set velocity has been reached, etc.	
		Analog input (A6SF only)	Velocity command	Velocity and direction	-
			Torque limit	Available	-
		Velocity range	1-6500r/min		
		Internal velocity command	8 velocity set values	A6N: Via RTEX network (100MBit) A6B: Via EtherCAT network	
		Smooth start-up and stopping	Individual setup of acceleration and deceleration from 0 to 10s/1000r/min, S-curve acceleration/deceleration ramp possible.		
		Zero speed clamp	Speed clamp input		
		Instantaneous speed observer	Available		
		Velocity control filter	Available		
	Torque control	Control input	Speed clamp input, "Torque under control" input, etc.	Reference signal, limit switch evaluation, etc.	
		Control output	Set torque has been reached (at predefined velocity), etc.	Set rotation speed reached, torque reached, etc.	
		Analog input	Velocity command	Set speed can be scaled	-
			Speed limit function	Speed can be scaled	-
		Full-closed control	Control input	1. Reset counter, 2. Command pulse inhibition, 3. Electronic gear, 4. Filter switching	-
	Control output		Position control complete (in position)	-	
	Pulse input		Opto coupler (pulse input A)	500kpps	-
Line receiver (pulse input B)			4Mpps	-	
Signal format			Differential input/square-wave pulse	-	
Electronic gear			Scaling of pulse frequency from 1/1000 to 1000 times	-	
Analog input	Smoothing filter		First order low pass filter or FIR filter, customizable	-	
	Torque control		Torque limit available	-	
Vibration suppression	Manual/automatic				
Scaling of counter pulses	From 1/40 to 160 times				
Other features	Autotuning	Automatic adjustment of the driver's rigidity to the vibration behavior of the mechanical parts and changes to the load.			
	Encoder resolution	Any value up to the maximal resolution of the encoder			
	Protective function	Error messages causing switch-off	Overvoltage, undervoltage, overspeed, overload, overheat, overcurrent, encoder error, etc.		
		Error messages requiring acknowledgement	Exceeding the position deviation, command pulse division error, EPROM error, etc.		
Alarm history	Can be logged for reference				

Specifications 400V AC

		MINAS A6SE, A6SG, A6SF	MINAS A6N	MINAS A6B
Input power	Main circuit	3-phase 380–480V (+10%, -15%), 50/60Hz		
	Control circuit	24V DC \pm 15%		
Operating conditions	Temperature	Operation temperature 0–55°C (without freezing). Storage temperature -20 to +65°C (maximum temperature guarantee: 80°C, 72 hours, without condensation ¹⁾		
	Ambient humidity	Operation and storage: 20–85% RH (non-condensing ¹⁾		
	Altitude	Max. 1000m above sea level		
	Vibration	Max. 5.88m/s ² , 10–60Hz		
	Pollution degree	Pollution degree 2 or 1		
Insulation voltage		Withstanding 1500V AC between the primary and grounding lines for one minute		
Control method		IGBT PWM method, sine wave drive		
Encoder		23 bit (8388608 resolution)		
External feedback scale (A6SF only)	A/B phase	A/B phase, initialization signal differential input		
	Serial	Serial communication type supported by Panasonic ²⁾		
Control signals	Input	10	8	8
	Output	6	3	8
Analog signals	Input (A6SF only)	3 inputs (16 bit A/D x 1, 12 bit A/D x 2)	/	/
	Output	2 outputs (analog monitor 1, analog monitor 2)		
Pulse signals	Input	2 inputs Both the open collector and the line driver interface can be connected.	/	/
	Output	4 outputs Line-driver output for encoder pulses (A/B/Z signal) or external feedback pulses (EXA/EXB/EXZ signal). Open collector output also available for Z or EXZ signal.	2 outputs Line driver output for encoder pulses (A/B signal).	Line driver output for encoder pulse (A/B phase signal) or external feedback pulses.
Interface	Realtime Express (RTEX)	/	Interface for motion control.	/
	EtherCAT	/	/	Interface for motion control.
	USB	USB interface to connect to computers (setup software PANATERM) for parameter setting or status monitoring. USB cable and wireless LAN dongle connection is possible. ³⁾		
	RS232	1:1 communication (not for A6SE)	/	/
	RS485	1: n communication (max. 31, not for A6SE)	/	/
	Modbus RTU	1:1 communication with superior controller is possible (in case of RS232), 1:n communication with superior controller is possible (in case of RS485)	/	/
Safety terminal (A6SF + A6NF + A6BF only)		Terminal to supports functional safety		
Front panel		5 button switches, 6-digit 7-segment LED	<ul style="list-style-type: none"> ▶ 2-digit rotary switch ▶ 2-digit 7-segment LED, 2 x LED for status indication ▶ Analog monitor output 	<ul style="list-style-type: none"> ▶ 2-digit 7-segment LED ▶ Network status LED (RUN, ERR, L/A IN, L/A OUT) ▶ Rotary switch for node address setting ▶ Analog monitor output (analog monitors 1 and 2)
Regeneration		Sizes A, B, G, H: Without built-in regenerative resistor (use external mounting) Sizes C–F: With built-in regenerative resistor (external regenerative resistor is also available.)		
Dynamic brake		Sizes A–G: Built-in, size H: External only		
Control mode		<ul style="list-style-type: none"> ▶ Position control ▶ Velocity control ▶ Torque control ▶ Position/velocity control ▶ Position/torque control ▶ Velocity/torque control ▶ Full-closed control 	<ul style="list-style-type: none"> ▶ Profile position mode (PP) ▶ Cyclic position mode (CP) ▶ Cyclic velocity mode (CV) ▶ Cyclic torque mode (CT) PP/CP/CV/CT modes are switchable each other with commands through RTEX.	<ul style="list-style-type: none"> ▶ Profile position mode (PP) ▶ Cyclic synchronous position mode (CSP) ▶ Homing mode (HM) ▶ Profile velocity mode (PV) ▶ Cyclic synchronous velocity mode (CSV) ▶ Torque profile mode (TQ) ▶ Cyclic synchronous torque mode (CST) These modes are switchable each other with commands through EtherCAT.

1) Please note that condensation tends to occur when temperature fall.

2) Please refer to the [Collaboration catalog](#) for suitable scale manufacturers and part numbers.

3) Do not use a wireless LAN dongle in countries where the use of such a dongle is prohibited by law.

Power supply for servo driver MINAS A6 Multi

		MADMPN14	MBDMPN24
Basic specifications	Rated power kW	15	30
	Frame	A	B
	Input voltage	3-phase, 380–480V AC (+10%, -15%)	
	Frequency Hz	50/60	
	Output voltage	535–675V DC (+10%, -15%)	
	Rated output current A	33	66
	Max. output current A	66	132
	DC bus capacity μ F	800	1800
	Control voltage	24V DC \pm 15% PELV or SELV (with holding brake 24V DC \pm 5%)	
	Max. rated current A	1.8	
	Insulation voltage	Withstands 1500V AC for one minute between primary circuit and ground	
	Brake resistor Ω	15	8
	Inputs (digital)	2 channels (12–26.4V, 10mA/channel)	
	Outputs	1 channel (24V DC or 200V DC type, 1.6A)	
	Operating conditions	Ambient temperature: 0–40°C, storage temperature: -20 to +65°C (max. temperature 80°C for 72 hours, no condensation)	
		Operation and storage: 20–85% RH (non-condensing)	
		Max. 1000m above sea level	
		Max. 5,88m/s ² , 10–60Hz (no continuous use at resonance frequency)	
	LED display	Ready, Error	
	Serial interface	RS485	
Weight kg	3.6	6.8	

Servo driver MINAS A6 Multi 400V AC

		MADM2A4KBX	MADM2A6KBX	MADM2AAKBX	MBDM1ABKBX
Input voltage		535–675V DC (+10%, -15%)			
DC bus capacity μ F		200	200	400	820
Control voltage		24V DC \pm 15% PELV or SELV (with holding brake 24V DC \pm 5%)			
Max. rated current A		2	2	2	1.8
Input power in kW		0.75	1.5	3	5
Axes		2	2	2	1
Rated output current A		2.3	4.7	9.1	13.6
Max. output current (peak) A		10.3	18.5	38.5	53.6
Insulation voltage		1500V AC for one minute between primary circuit and ground			
Frame		A	A	A	B
Safety functions		STO, SBC, SS1, SLS, SSM, SSR, SS2, SOS, SLA, SAR, SLI, SDI, SLP, SCA			
Operating conditions	Temperature	Ambient temperature: 0-40°C, storage temperature: -20 to +65°C (max. temperature 80°C for 72 h, no condensation)			
	Ambient humidity	Operation and storage: 20–85% RH (non-condensing)			
	Altitude	Max. 1000m above sea level			
	Vibration	Max. 5.88m/s ² , 10–60Hz			
Encoder	Incremental	23 bit (resolution 8388608ppr)			
	Absolute	23-bit, no battery required, set parameter Pr.015 to 1			
Control signals (digital)	Inputs	8			
	Output points	2			
Signals for safety function (digital)	Inputs	5			
	Output points	2			
Output signals for brake (digital)	General	1 connection for brake cable			
	Safety function	2			
Setup support software		PANATERM (via USB, via EoE) PANATERM for safety functions (via USB, via EoE)			
LED display		2-digit 7 segment LED. Network status LED (RUN, ERR, L/A IN, L/A OUT) Rotary switch for setting the EtherCAT node address DIP switch for setting the node address for cross communication			
Network	Industrial Ethernet	<ul style="list-style-type: none"> › Profile position mode (pp) › Cyclic synchronous position mode (csp) › Homing mode (hm) › Profile velocity mode (pv) › Cyclic synchronous velocity mode (csv) › Torque profile mode (tq) › Cyclic synchronous torque mode (cst) 			
Serial interface		RS485			
Dynamic brake		Built in			
Weight kg		3.4	3.4	3.4	5.6

200/400V AC

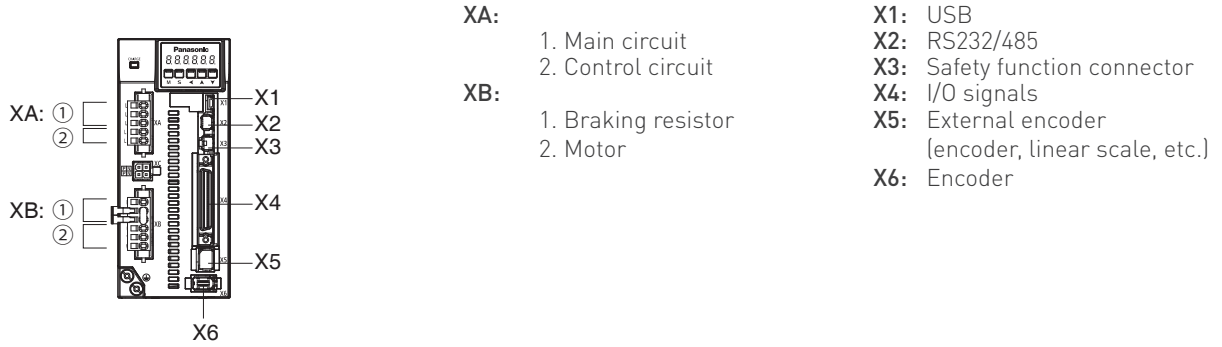

Frame A, B

All dimensions are in mm

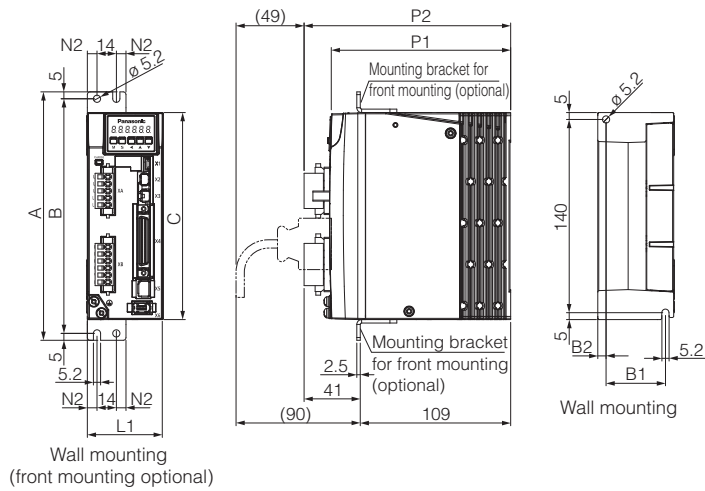

Frame C, D

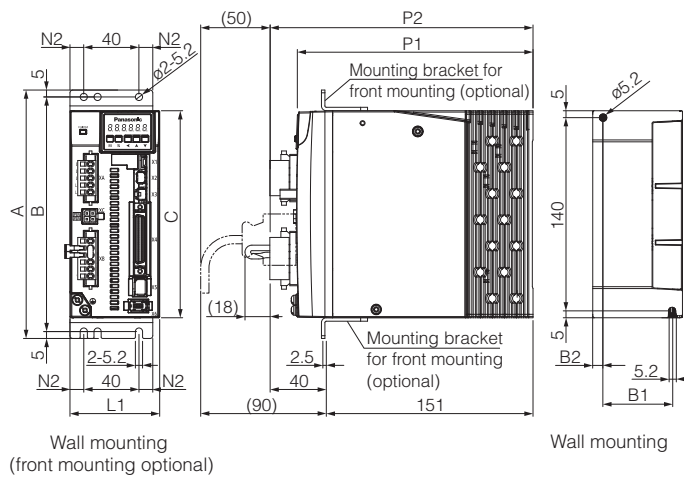

Frame E

All dimensions are in mm

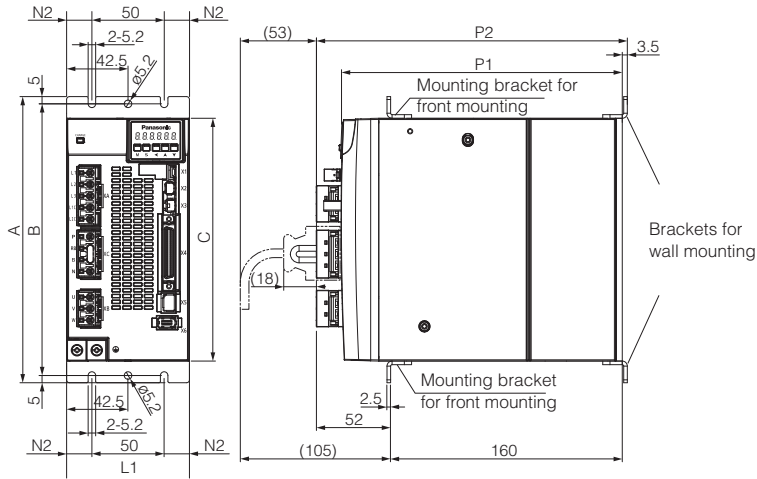

Frame F

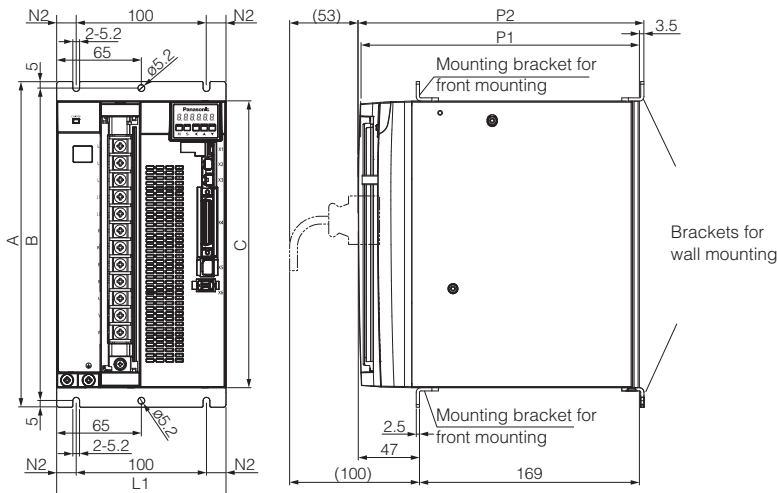

Frame	Voltage	Width			Depth			Depth		Control panel		Weight
		L1	N1	N2	A	B	C	P1	P2	B1	B2	
A	200/400V DC	40	-	7	180	170	150	130	150	28	6	0.8kg
B	200/400V DC	55	-	7	180	170	150	130	150	43	6	1.0kg
C	200/400V DC	65	40	10	180	170	150	170	191	50	7.5	1.6kg
D	200/400V DC	85	40	10	180	170	150	170	191	70	7.6	2.1kg
E	200/400V DC	85	50	17.5	198	188	168	216	193	-	-	2.5kg
F	200/400V DC	130	100	17.5	250	240	220	219.5	216	-	-	4.8kg

3D-CAD data is available in stp format for downloading from our website:
<https://www.panasonic-electric-works.com/eu/downloadcenter.htm>
 Home -> Download center-> Automation products -> Servo drives -> CAD



Power supply for servo driver MINAS A6 Multi

All dimensions are in mm

Frame A

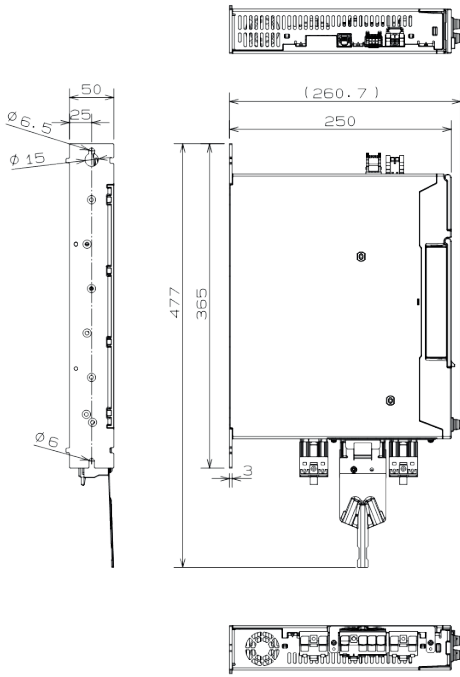

Frame B

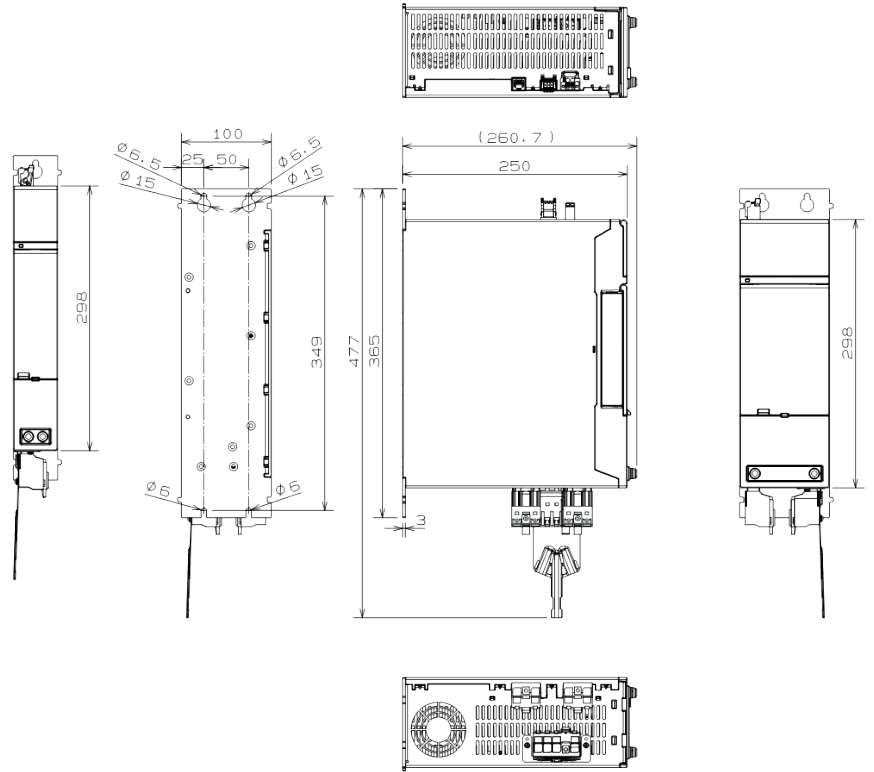

Servo driver MINAS A6 Multi 400V AC

Frame A

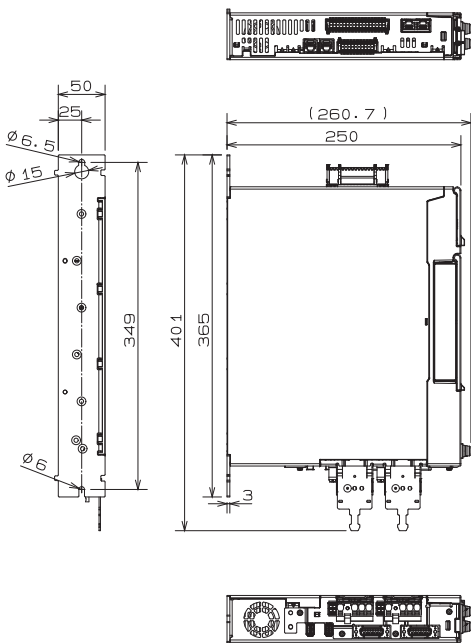

Frame B

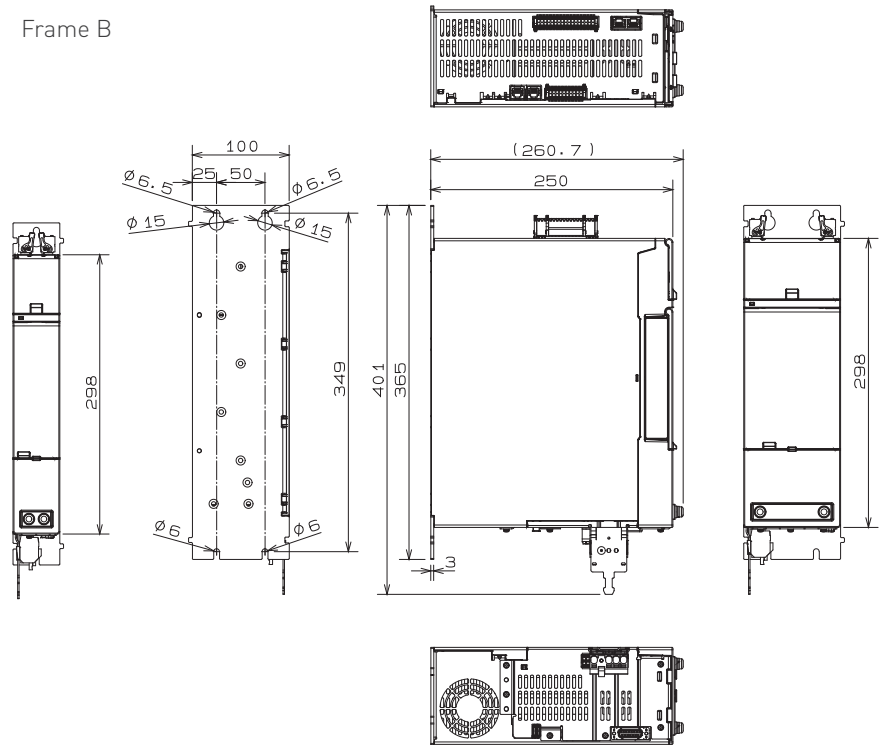

200V AC

MSMF (low inertia moment) 50–1500W, 200V AC

Servo motor	MSMF5AZL1□□	MSMF012L1□□	MSMF022L1□□	MSMF042L1□□	MSMF082L1□□	MSMF092L1□□	MSMF102L1□□	MSMF152L1□□	
Rated power W	50	100	200	400	750	1000		1500	
Required power kVA	0.5			0.9	1.3	1.8	2.3		
Rated current A	1.1		1.5	2.4	4.1	5.7	6.6	8.2	
Max. current A o-p	4.7		6.5	10.2	17.4	24.2	28	35	
Rotational speed r/min	Rated rotational speed	3000							
	Max. rotational speed	6000					5000		
Weight kg	Without holding brake	0.32	0.47	0.82	1.2	2.3	2.8	3.6	4.6
	With holding brake	0.53	0.68	1.3	1.7	3.1	3.6	4.7	5.6
Torque Nm	Nominal	0.16	0.32	0.64	1.27	2.39	3.18	3.18	4.77
	Maximal	0.48	0.95	1.91	3.82	7.16	9.55	9.55	14.3
Encoder	Pulses	23 bit incremental							
	Resolution	8388608ppr							
Braking resistor frequency times/min	Without external braking resistor	No limit							
	With external braking resistor	No limit							
Moment of inertia of rotor (x10 ⁻⁴ kg · m ²)	Without holding brake	0.026	0.048	0.14	0.27	0.96	1.26	2.15	3.1
	With holding brake	0.029	0.051	0.17	0.3	1.06	1.36	2.47	3.45
Recommended inertia ratio between load and rotor	Max. 30:1				Max. 20:1		Max. 15:1		
Operating conditions	Temperature (without frost)	0–55°C							
	Ambient humidity	20–85% RH (non-condensing)							
	Altitude	Max. 1000m above sea level							
	Vibration	5.88m/s ²							
Holding brake specifications (The holding brake is engaged when the power for the servo driver is shut off. Do not use the holding brake when the motor is in motion.)									
Static friction torque Nm	Min. 0.294		Min. 1.27		Min. 2.45	Min. 3.8		Min. 8	
Engaging time ms	Max. 35		Max. 50		Max. 70		Max. 50		
Releasing time ms	Max. 20		Max. 15		Max. 20		Max. 15		
Excitation current A DC	0.3		0.36		0.42		0.81 ±10%		
Releasing voltage V DC	Min. 1				Min. 1		Min. 2		
Excitation voltage V DC	24 ±1.2				24 ±1.2		24 ±2.4		
Permissible load and thrust at output shaft									
Radial load P direction N*	During installation	147		392		686		980	
	During operation	68.6		245		392		490	
Axial thrust (push) N*	During installation	88		147		294		588	
	During operation	58.8		98		147		196	
Axial thrust (pull) N*	During installation	117.6		196		392		686	
	During operation	58.8		98		147		196	

□□ Motor type, see brochure *Servo drives 4247eu*en page 20* Explanation, see *MINAS A6 Series, Additional Technical Information* page 12

MDMF (medium inertia moment) 1000–1500W, 200V AC

Servo motor		MDMF102L1□□	MDMF152L1□□
Rated power		1000	1500
Required power kVA		1.8	2.3
Rated current A		5.2	8
Max. current A o-p		22	32
Rotational speed r/min	Rated rotational speed	2000	
	Max. rotational speed	3000	
Weight kg	Without holding brake	4.6	5.7
	With holding brake	6.1	7.2
Torque Nm	Nominal	4.77	7.16
	Maximal	14.3	21.5
Encoder	Pulses	23 bit incremental	
	Resolution	8388608ppr	
Braking resistor frequency times/min	Without external braking resistor	No limit	
	With external resistor	No limit	
Moment of inertia of rotor (x10 ⁻⁴ kg · m ²)	Without holding brake	6.18	9.16
	With holding brake	7.4	10.4
Recommended inertia ratio between load and rotor		Max.10:1	
Operating conditions	Temperature (without frost)	0–55°C	
	Ambient humidity	20–85% RH (non-condensing)	
	Altitude	Max. 1000m above sea level	
	Vibration	5.88m/s ²	
Holding brake specifications (The holding brake is engaged when the power for the servo driver is shut off. Do not use the holding brake when the motor is in motion.)			
Static friction torque Nm		Min. 13.7	
Engaging time ms		Max. 100	
Releasing time ms		Max. 50	
Excitation current A DC		0.79 ±10%	
Releasing voltage V DC		Min. 2	
Excitation voltage V DC		24 ±2.4	
Permissible load and thrust at output shaft			
Radial load P direction N*	During installation	980	
	During operation	490	
Axial thrust (push) N*	During installation	588	
	During operation	196	
Axial thrust (pull) N*	During installation	689	
	During operation	196	

□□ Motor type, see brochure *Servo drives 4247eu/en*, page 20

*

Permissible load and thrust at output shaft

Radial load, P direction

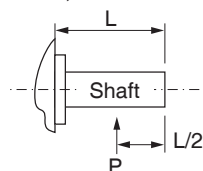

Thrust load, A and B direction

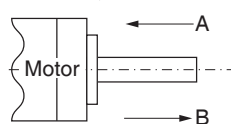

MHMF (high inertia moment) 50–1500W, 200V AC

Servo motor		MHMF5AZL1□□	MHMF012L1□□	MHMF022L1□□	MHMF042L1□□	MHMF082L1□□	MHMF092L1□□	MHMF102L1□□	MHMF152L1□□	
Rated power W		50	100	200	400	750	1000		1500	
Required power kVA		0.5		0.5	0.9	1.3	2.3	1.8	2.3	
Rated current A		1.1		1.4	2.1	3.8	5.7	5.2	8	
Max. current A o-p		5.5		6.9	10.4	18.8	28.2	22	34	
Rotational speed r/min	Rated rotational speed	3000						2000		
	Max. rotational speed	6500			6000			3000		
Weight kg	Without holding brake	0.31	0.42	0.78	1.2	2.3	2.8	6.1	7.7	
	With holding brake	0.53	0.64	1.2	1.6	3	3.5	7.6	9.2	
Torque Nm	Nominal	0.16	0.32	0.64	1.27	2.39	3.18	4.77	7.16	
	Maximal	0.56	1.11	2.23	4.46	8.36	11.1	14.3	21.5	
Encoder	Pulses	23 bit incremental								
	Resolution	8388608ppr								
Braking resistor frequency times/min	Without external braking resistor	No limit								
	With external braking resistor	No limit								
Moment of inertia of rotor (x10 ⁻⁴ kg · m ²)	Without holding brake	0.038	0.071	0.29	0.56	1.56	2.03	22.9	33.4	
	With holding brake	0,042	0.074	0.31	0.58	1.66	2.13	24.1	34.6	
Recommended inertia ratio between load and rotor		Max. 30:1			Max. 20:1			Max. 5:1		
Operating conditions	Temperature (without frost)	0–55°C								
	Ambient humidity	20–85% RH (non-condensing)								
	Altitude	Max. 1000m above sea level								
	Vibration	5.88m/s ²								
Holding brake specifications (The holding brake is engaged when the power for the servo driver is shut off. Do not use the holding brake when the motor is in motion.)										
Static friction torque Nm		Min. 0.38		Min. 1.6		Min. 3.8		Min. 13.7		
Engaging time ms		Max. 35		Max. 50		Max. 70		Max. 100		
Releasing time ms		Max. 20		Max. 20		Max. 20		Max. 50		
Excitation current A DC		0.3		0.36		0.42		0.79 ±10%		
Releasing voltage V DC		Min. 1						Min. 2		
Excitation voltage V DC		24 ±2.4								
Permissible load and thrust at output shaft										
Radial load P direction N*	During installation	147	147	392	686	980				
	During operation	68.6	68.6	245	392	490				
Axial thrust (push) N*	During installation	88	88	147	294	588				
	During operation	49	58.8	98	147	196				
Axial thrust (pull) N*	During installation	117.6	117.6	196	392	686				
	During operation	49	58.8	98	147	196				

□□ Motor type, see brochure *Servo drives 4247eu* page 20* Explanation, see *MINAS A6 Series, Additional Technical Information* page 12

400V AC

MSMF (low inertia moment) 1kW–5kW, 400V AC

Servo motor (standard)		MSMF104L100M	MSMF154L100M	MSMF204L100M	MSMF304L100M	MSMF404L100M	MSMF504L100M
Servo motor (battery-free encoder)		MSMF104A100M	MSMF154A100M	MSMF204A100M	MSMF304A100M	MSMF404A100M	MSMF504A100M
Rated power W		1000	1500	2000	3000	4000	5000
Rated current A		3.3	4.1	5.7	9.1	10.1	12.6
Max. current A o-p		14	17.5	24	38.5	42.7	53.6
Rotational speed r/min	Rated rotational speed	3000					
	Max. rotational speed	5500			5000		
Weight kg	Without holding brake	3.6	4.6	5.6	8.7	11.5	14.5
	With holding brake	4.7	5.6	6.6	9.9	13.2	16.1
Torque Nm	Nominal	3.18	4.77	6.37	9.55	12.7	15.9
	Maximal	9.55	14.3	19.1	28.7	38.2	47.8
Encoder	Pulses	23 bit					
	p/r	8388608ppr					
Moment of inertia of rotor ($\times 10^{-4} \text{kg} \cdot \text{m}^2$)	Without holding brake	2.15	3.1	4.06	7.04	14.4	19
	With holding brake	2.47	3.45	4.41	7.38	15.6	20.2
Operating conditions	Temperature (without frost)	0–40°C					
	Ambient humidity	20–85% RH (non-condensing)					
	Altitude	Max. 1000m above sea level					
	Vibration	Max. 49m/s ²					
Holding brake specifications (The holding brake is engaged when the power for the servo driver is shut off. Do not use the holding brake when the motor is in motion.)							
Static friction torque Nm		Min. 8		Min. 12	Min. 16.2	Min. 22	
Engaging time ms		Max. 50		Max. 80	Max. 110		
Releasing time ms		Max. 15			Max. 50		
Excitation current A DC		0.81 ±10%				0.90 ±10%	
Releasing voltage V DC		Min. 2					
Excitation voltage V DC		24 ±2.4					
Permissible load and thrust at output shaft							
Radial load P direction N*	During installation	980					
	During operation	490			784		
Axial thrust (push) N*	During installation	588					
	During operation	196			343		
Axial thrust (pull) N*	During installation	686					
	During operation	196			343		

□ Motor type, see brochure *Servo drives 4247euen* page 22

* Explanation, see *MINAS A6 Series, Additional Technical Information* page 12

MDMF (medium inertia moment) 1kW–5kW, 400V AC

Servo motor (standard)		MDMF104L100M	MDMF154L100M	MDMF204L100M	MDMF304L100M	MDMF404L100M	MDMF504L100M
Servo motor (battery-free encoder)		MDMF104A100M	MDMF154A100M	MDMF204A100M	MDMF304A100M	MDMF404A100M	MDMF504A100M
Rated power W		1000	1500	2000	3000	4000	5000
Rated current A		2.7	4	5.1	8.6	10	12
Max. current A o-p		11.4	17	21.6	36.4	42.5	51
Rotational speed r/min	Rated rotational speed	2000					
	Max. rotational speed	3500					3000
Weight kg	Without holding brake	4.6	5.7	6.9	9.3	13.4	15.6
	With holding brake	6.1	7.2	8.4	10.9	16.8	19
Torque Nm	Nominal	4.77	7.16	9.55	14.3	19.1	23.87
	Maximal	14.3	21.5	28.7	43	57.3	71.6
Encoder	Pulses	23 bit					
	p/r	8388608ppr					
Moment of inertia of rotor (x10 ⁻⁴ kg · m ²)	Without holding brake	6.18	9.16	12.1	18.6	46.9	58.2
	With holding brake	7.4	10.4	13.3	19.6	52.3	63
Operating conditions	Temperature (without frost)	0–40°C					
	Ambient humidity	20–85% RH (non-condensing)					
	Altitude	Max. 1000m above sea level					
	Vibration	Max. 49m/s ²					
Holding brake specifications (The holding brake is engaged when the power for the servo driver is shut off. Do not use the holding brake when the motor is in motion.)							
Static friction torque Nm		Min. 13.7			Min. 22	Min. 25	Min. 44.1
Engaging time ms		Max. 100			Max. 110	Max. 80	Max. 150
Releasing time ms		Max. 50				Max. 25	Max. 30
Excitation current A DC		0.79 ±10%			0.90 ±10%	1.29 ±10%	
Releasing voltage V DC		Min. 2					
Excitation voltage V DC		24 ±2.4					
Permissible load and thrust at output shaft							
Radial load P direction N*	During installation	980				1666	
	During operation	490			784		
Axial thrust (push) N*	During installation	588				784	
	During operation	196			343		
Axial thrust (pull) N*	During installation	686				980	
	During operation	196			343		

□□ Motor type, see brochure *Servo drives 4247even* page 22* Explanation, see *MINAS A6 Series, Additional Technical Information* page 12

MHMF (high inertia moment) 1kW–5kW, 400V AC

Servo motor (standard)		MHMF104L100M	MHMF154L100M	MHMF204L100M	MHMF304L100M	MHMF404L100M	MHMF504L100M
Servo motor (battery-free encoder)		MHMF104A100M	MHMF154A100M	MHMF204A100M	MHMF304A100M	MHMF404A100M	MHMF504A100M
Rated power W		1000	1500	2000	3000	4000	5000
Rated current A		2.7	4	6.2	8.8	10	12
Max. current A o-p		11.4	17	26.5	37.4	42.5	51
Rotational speed r/min	Rated rotational speed	2000					
	Max. rotational speed	3500					3000
Weight kg	Without holding brake	6.1	7.7	11.3	13.8	16.2	19.6
	With holding brake	7.6	9.2	14.6	17.2	19.4	22.8
Torque Nm	Nominal	4.77	7.16	9.55	14.3	19.1	23.9
	Maximal	14.3	21.5	28.7	43	57.3	71.6
Encoder	Pulses	23 bit					
	p/r	8388608ppr					
Moment of inertia of rotor (x10 ⁻⁴ kg · m ²)	Without holding brake	22.9	33.4	55.7	85.3	104	146
	With holding brake	24.1	34.6	61	90.7	110	151
Operating conditions	Temperature (without frost)	0–40°C					
	Ambient humidity	20–85% RH (non-condensing)					
	Altitude	Max. 1000m above sea level					
	Vibration	Max. 49m/s ²					
Holding brake specifications (The holding brake is engaged when the power for the servo driver is shut off. Do not use the holding brake when the motor is in motion.)							
Static friction torque Nm		Min. 13.7			Min. 25		Min. 44.1
Engaging time ms		Max. 100			Max. 80		Max. 150
Releasing time ms		Max. 50			Max. 25		Max. 30
Excitation current A DC		0.79 ±10%			1.29 ±10%		
Releasing voltage V DC		Min. 2					
Excitation voltage V DC		24 ±2.4					
Permissible load and thrust at output shaft							
Radial load P direction N*	During installation	980			1666		
	During operation	490			784		
Axial thrust (push) N*	During installation	588			784		
	During operation	196			343		
Axial thrust (pull) N*	During installation	686			980		
	During operation	196			343		

□ Motor type, see brochure *Servo drives 424Teu*en page 22

* Explanation, see *MINAS A6 Series, Additional Technical Information* page 12

200V AC

MSMF (low inertia moment), 200V AC

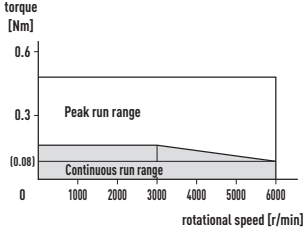
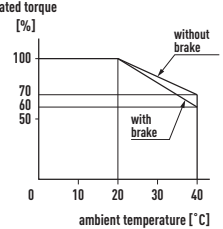
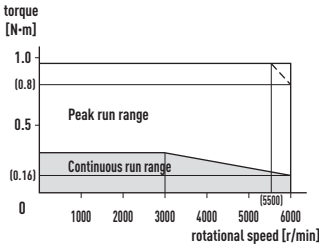
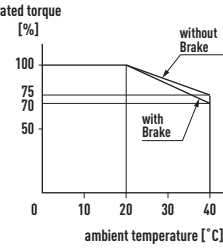
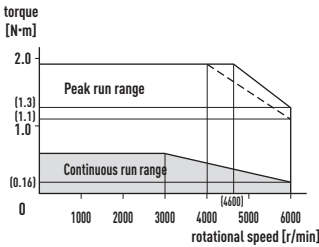
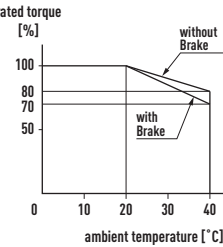
Model	Torque characteristic	Derating curve
MSMF5AZL1		
MSMF012L1		
MSMF022L1		

MSMF (low inertia moment), 200V AC

Model	Torque characteristic	Derating curve
MSMF042L1	<p>torque [N·m]</p> <p>rotational speed [r/min]</p> <p>Peak run range</p> <p>Continuous run range</p> <p>4.0</p> <p>2.0 (1.6)</p> <p>0.64</p> <p>0 1000 2000 3000 4000 5000 6000</p> <p>(3100) (3600)</p>	<p>rated torque [%]</p> <p>ambient temperature [°C]</p> <p>100</p> <p>75</p> <p>50</p> <p>0 10 20 30 40</p>
MSMF082L1	<p>torque [N·m]</p> <p>rotational speed [r/min]</p> <p>Peak run range</p> <p>Continuous run range</p> <p>8.0</p> <p>4.0 (3.2)</p> <p>0.64</p> <p>0 1000 2000 3000 4000 5000 6000</p> <p>(3200) (3600)</p>	<p>rated torque [%]</p> <p>ambient temperature [°C]</p> <p>100</p> <p>50</p> <p>0 10 20 30 40</p>
MSMF092L1	<p>torque [N·m]</p> <p>rotational speed [r/min]</p> <p>Peak run range</p> <p>Continuous run range</p> <p>8.0</p> <p>5.5</p> <p>4.0</p> <p>0 1000 2000 3000 4000 5000 6000</p> <p>(3400) (4200)</p>	<p>rated torque [%]</p> <p>ambient temperature [°C]</p> <p>100</p> <p>50</p> <p>0 10 20 30 40</p>
MSMF102L1	<p>torque [N·m]</p> <p>rotational speed [r/min]</p> <p>Peak run range</p> <p>Continuous run range</p> <p>10</p> <p>6.0</p> <p>5</p> <p>4.0</p> <p>1.1</p> <p>0 1000 2000 3000 4000 5000</p> <p>(3800) (4200)</p>	<p>rated torque [%]</p> <p>ambient temperature [°C]</p> <p>100</p> <p>50</p> <p>0 10 20 30 40</p>
MSMF152L1	<p>torque [N·m]</p> <p>rotational speed [r/min]</p> <p>Peak run range</p> <p>Continuous run range</p> <p>15</p> <p>7.5</p> <p>4.0</p> <p>0 1000 2000 3000 4000 5000</p> <p>(3200) (3600)</p>	<p>rated torque [%]</p> <p>ambient temperature [°C]</p> <p>100</p> <p>50</p> <p>0 10 20 30 40</p>

MDMF (medium inertia moment), 200V AC

Model	Torque characteristic	Derating curve
MDMF102L1	<p>torque [Nm]</p> <p>15 10 (7.7) 6.3 5 3.0</p> <p>Peak run range</p> <p>Continuous run range</p> <p>0 1000 2000 (2200) 3000</p> <p>rotational speed [r/min]</p>	<p>rated torque [%]</p> <p>100 50</p> <p>0 10 20 30 40</p> <p>ambient temperature [°C]</p>
MDMF152L1	<p>torque [N·m]</p> <p>15 12.0 10 6.6 5 3.0</p> <p>Peak run range</p> <p>Continuous run range</p> <p>0 1000 2000 (2300) 3000</p> <p>rotational speed [r/min]</p>	<p>rated torque [%]</p> <p>100 50</p> <p>0 10 20 30 40</p> <p>ambient temperature [°C]</p>

MHMF (high inertia moment), 200V AC

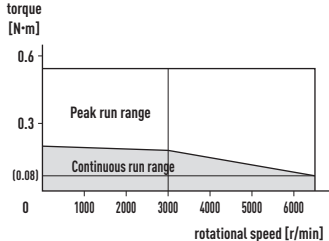
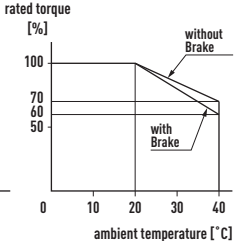
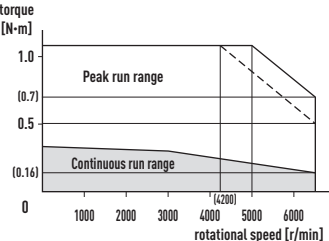
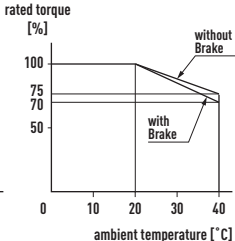
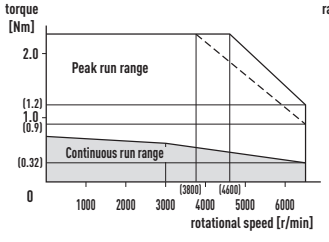
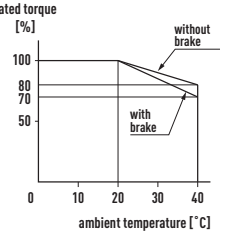
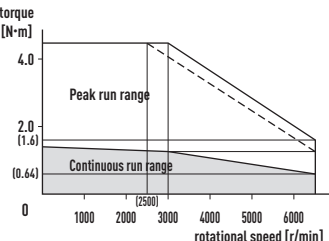
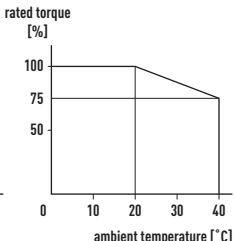
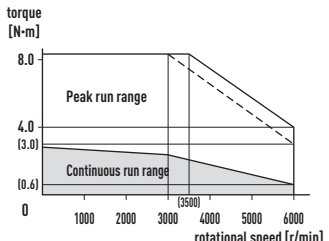
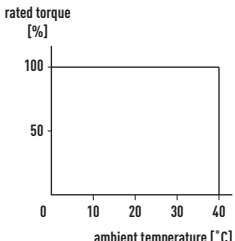
Model	Torque characteristic	Derating curve
MHMF5AZL1		
MHMF012L1		
MHMF022L1		
MHMF042L1		
MHMF082L1		

200V AC

MHMF (high inertia moment), 200V AC

Model	Torque characteristic	Derating curve
MHMF092L1		
MHMF102L1		
MHMF152L1		

400V AC

MSMF (low inertia moment), 400V AC

Model	Torque characteristic	Derating curve
MSMF104□□□M		
MSMF154□□□M		
MSMF204□□□M		
MSMF304□□□M		
MSMF404□□□M		
MSMF504□□□M		

MDMF (medium inertia moment), 400V AC

Model	Torque characteristic	Derating curve
MDMF104□□□M		
MDMF154□□□M		
MDMF204□□□M		
MDMF304□□□M		
MDMF404□□□M		
MDMF504□□□M		<p data-bbox="1177 952 1321 974">Characteristic curve</p>

MHMF (high inertia moment), 400V AC

Model	Torque characteristic	Derating curve
MDMF104□□□M		
MDMF154□□□M		
MDMF204□□□M		
MDMF304□□□M		
MDMF404□□□M		
MDMF504□□□M		

200V AC

MSMF (low inertia moment) 50–1500W, 200V AC

Top view of the motor:

- The encoder connection is rotated 30° to the axial direction of the motor for MSMF5AZL1 and MSMF012L1□□.
- The brake connection is rotated 30° to the axial direction of the motor for MSMF5AZL1 and MSMF012L1□□ (only motors with holding brake).

MSMF5AZL1□□.

Without brake

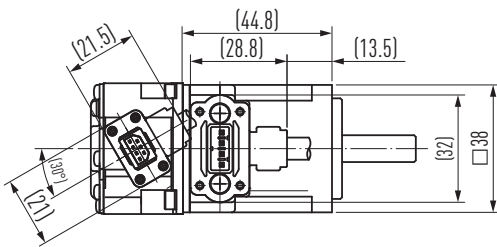

With brake

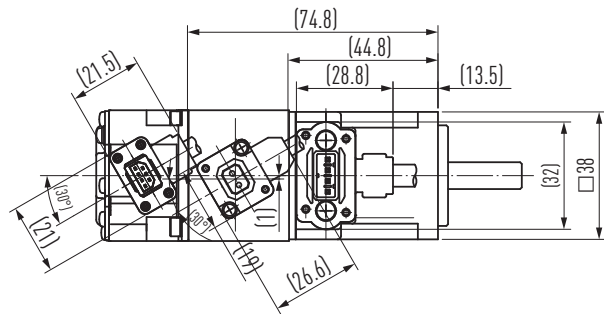

MSMF012L1□□.

Without brake

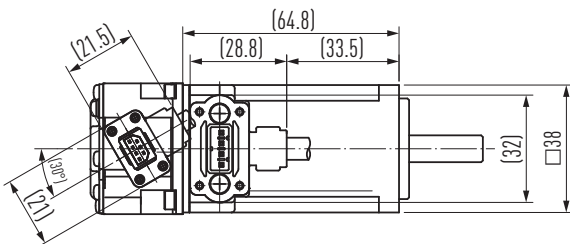

With brake

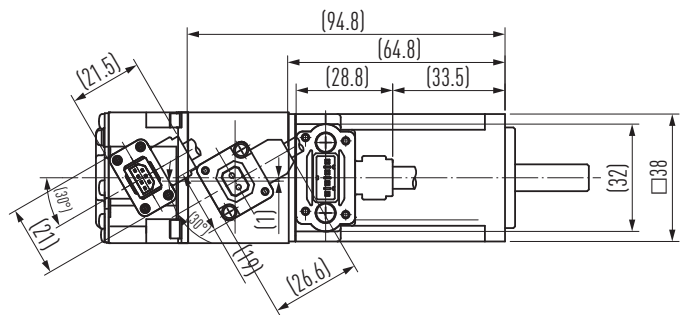

MSMF (low inertia moment) 50-1500W, 200V AC

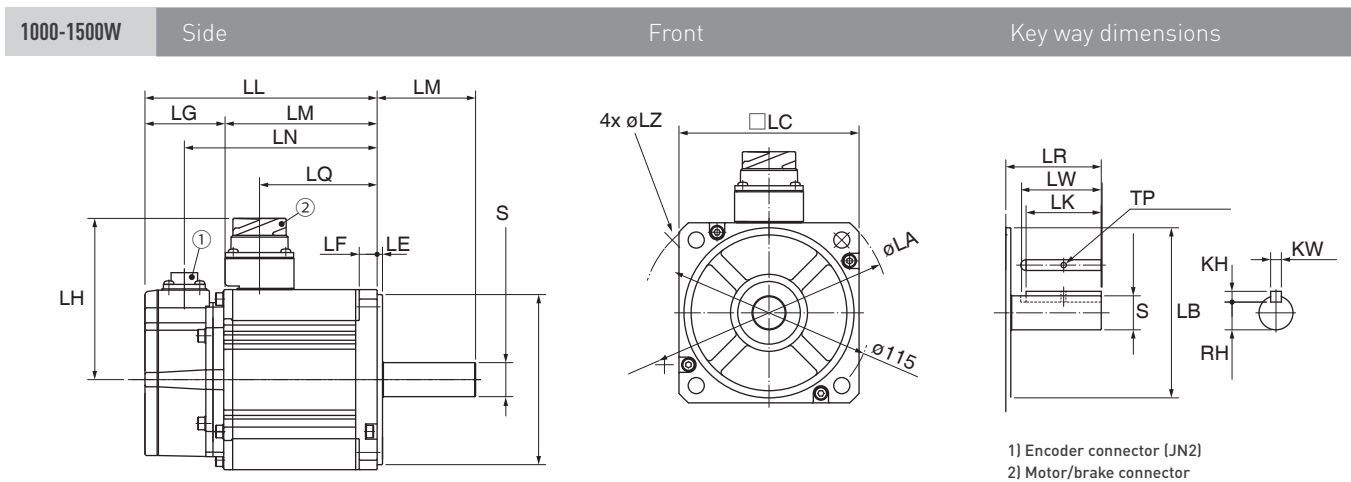
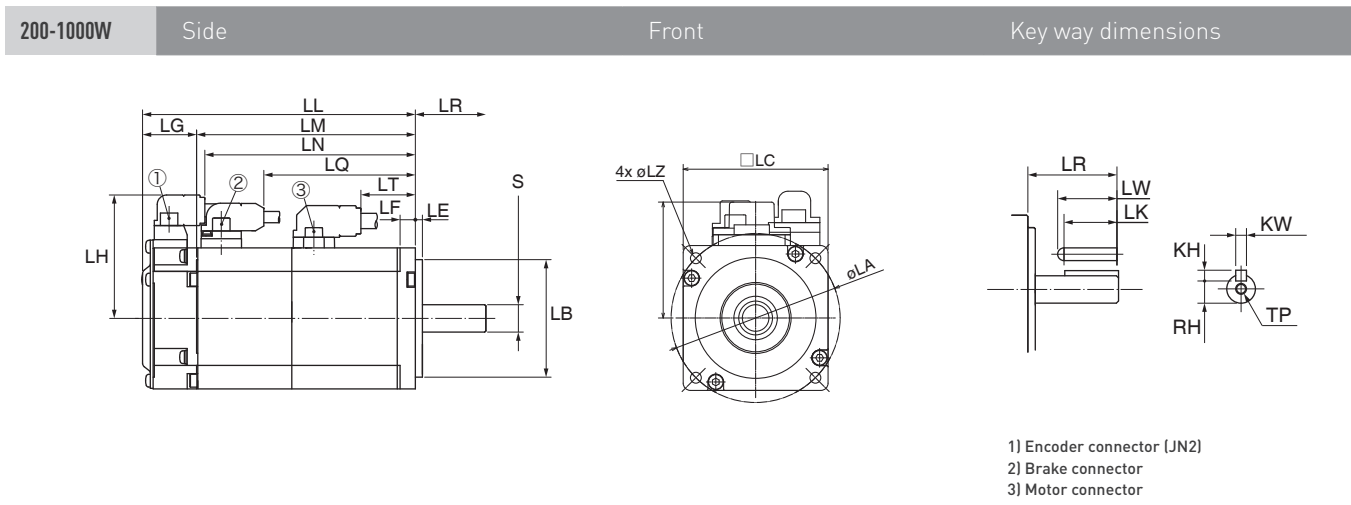
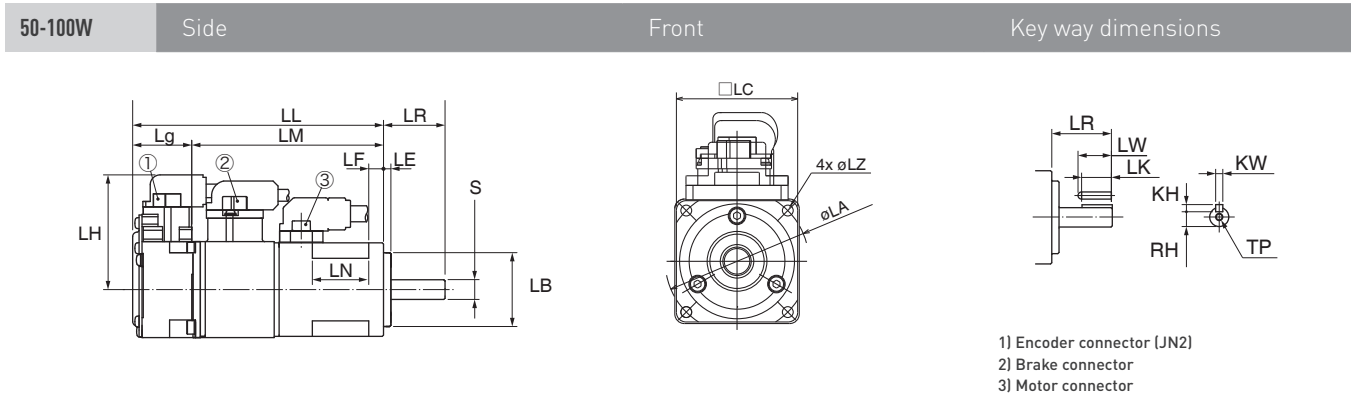

Note: All illustrations show motors with holding brake.

MSMF (low inertia moment) 50–1500W, 200V AC

Rated power		W	50	100	200	400	750	1000		1500
Servo motor		200V AC	MSMF5AZL1□□	MSMF012L1□□	MSMF022L1□□	MSMF042L1□□	MSMF082L1□□	MSMF092L1□□	MSMF102L1□□	MSMF152L1□□
Encoder		ppr	23-bit absolute, 8388608							
LL	Without holding brake	mm	72	92	79.5	99	112.2	127.2	136	154.5
	With holding brake	mm	102	122	116	135.5	148.2	163.2	163	181.5
LR		mm	25	25	30	30	35	35	55	55
LG		mm	24	24	23	23	26	26	44	44
LM	Without holding brake	mm	48	68	56.5	76	86.2	101.2	92	110.5
	With holding brake	mm	78	98	93	112.5	122.2	137.2	119	137.5
LN	Without holding brake	mm	23	43	53	72.5	85.7	100.7	114	132.5
	With holding brake	mm	-	-	89.5	109	121.7	136.7	141	159.5
LQ	Without holding brake	mm	-	-	-	-	-	-	72	90.5
	With holding brake	mm	-	-	64.7	83.9	94.8	109.8	59	77.5
LT		mm	-	-	23.1	42.6	52.4	67.4	-	-
LH	Without holding brake	mm	46.6	46.6	52.5	52.5	60	60	90	90
	With holding brake	mm	46.6	46.6	52.5	52.5	61.6	61.6	101	101
LF		mm	6	6	6.5	6.5	8	8	10	10
LE		mm	3	3	3	3	3	3	3	3
S		mm	∅ 8 h6	∅ 8 h6	∅ 11 h6	∅ 14 h6	∅ 19 h6	∅ 19 h6	∅ 19 h6	∅ 19 h6
LB		mm	∅ 30 h7	∅ 30 h7	∅ 50 h7	∅ 50 h7	∅ 70 h7	∅ 70 h7	∅ 95 h7	∅ 95 h7
LC		mm	□38	□38	□60	□60	□80	□80	□100	□100
LZ		mm	4 x ∅ 3.4	4 x ∅ 3.4	4 x ∅ 4.5	4 x ∅ 4.5	4 x ∅ 6	4 x ∅ 6	4 x ∅ 9	4 x ∅ 9
LA		mm	∅ 45 ±0.2	∅ 45 ±0.2	∅ 70 ±0.2	∅ 70 ±0.2	∅ 90 ±0.2	∅ 90 ±0.2	∅ 115	∅ 115
LD		mm	-	-	-	-	-	-	∅ 135	∅ 135
Key way	LW	mm	14	14	20	25	25	25	45	45
	LK	mm	12.5	12.5	18	22.5	22	22	42	42
	KW	mm	3 h9	3 h9	4 h9	5 h9	6 h9	6 h9	6 h9	6 h9
	KH	mm	3	3	4	5	6	6	6	6
	RH	mm	6.2	6.2	8.5	11	15.5	15.5	15.5	15.5
	TP	mm	M3, depth 6	M3, depth 6	M4, depth 8	M5, depth 10	M5, depth 10	M5, depth 10	M5, depth 10	M3, through-hole
Weight	Without holding brake	kg	0.32	0.47	0.82	1.2	2.3	2.8	3.6	4.6
	With holding brake	kg	0.53	0.68	1.3	1.7	3.1	3.6	4.7	5.6

□□ Motor type, see brochure *Servo drives 4247eu*en page 20

MDMF (medium inertia moment) 1000–1500W, 200V AC

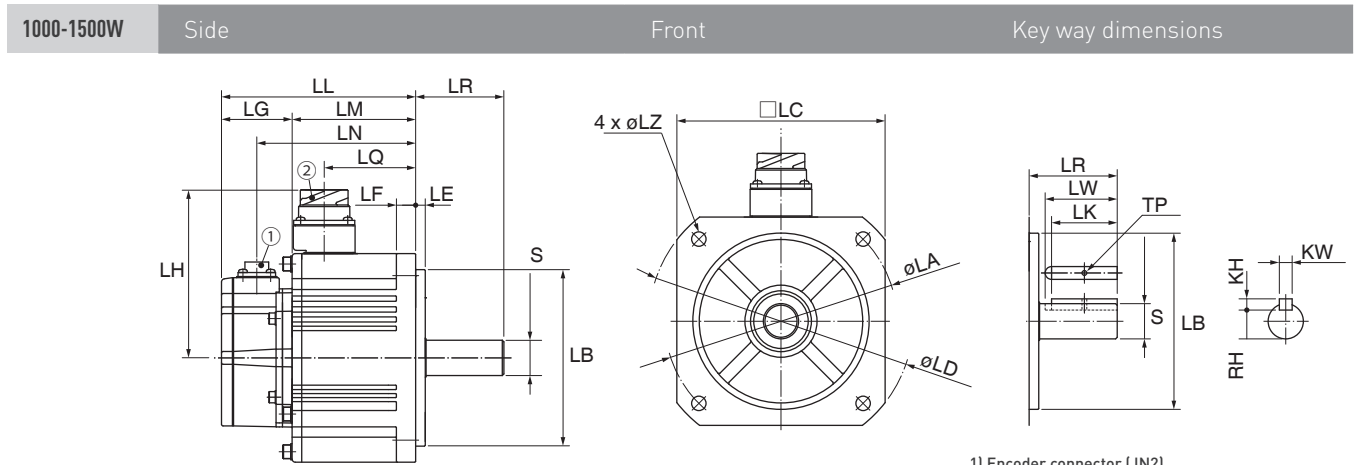

- 1) Encoder connector (JN2)
2) Motor/brake connector

Note: Illustration shows motor with holding brake

MDMF (medium inertia moment) 1000–1500W, 200V AC

Rated power		W	1000	1500
Servo motor		200V AC	MDMF102L1□□	MDMF152L1□□
Encoder		ppr	23-bit absolute, 8388608	
LL	Without holding brake	mm	121	135
	With holding brake	mm	149	163
LR		mm	55	55
LG		mm	44	44
LM	Without holding brake	mm	77	91
	With holding brake	mm	105	119
LN	Without holding brake	mm	99	113
	With holding brake	mm	127	141
LQ	Without holding brake	mm	57	71
	With holding brake	mm	43	57
LH	Without holding brake	mm	105	105
	With holding brake	mm	116	116
LF		mm	12	12
LE		mm	6	6
S		mm	∅ 22 h6	∅ 22 h6
LB		mm	∅ 110 h7	∅ 110 h7
LC		mm	□130	□130
LZ		mm	4 x ∅ 9	4 x ∅ 9
LA		mm	∅ 145	∅ 145
LD		mm	∅ 165	∅ 165
Key way	LW	mm	45	45
	LK	mm	41	41
	KW	mm	8 h9	8 h9
	KH	mm	7	7
	RH	mm	18	18
	TP	mm	M3, through-hole	M3, through-hole
Weight	Without holding brake	kg	4.6	5.7
	With holding brake	kg	6.1	7.2

□□ Motor type, see brochure *Servo drives 4247eu* page 20

MHMF (high inertia moment) 50–1500W, 200V AC

50-100W Side Front Key way dimensions

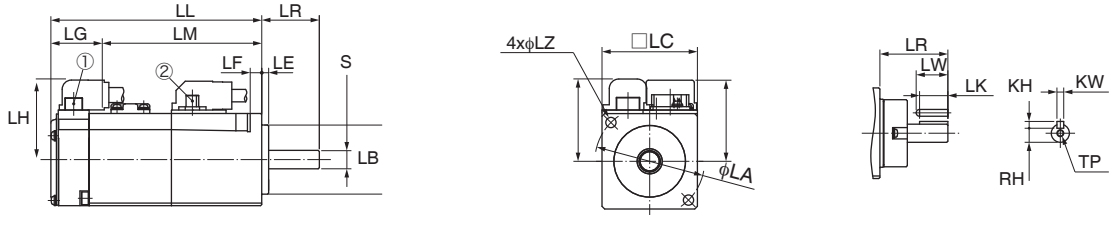

200-1000W Side Front Key way dimensions

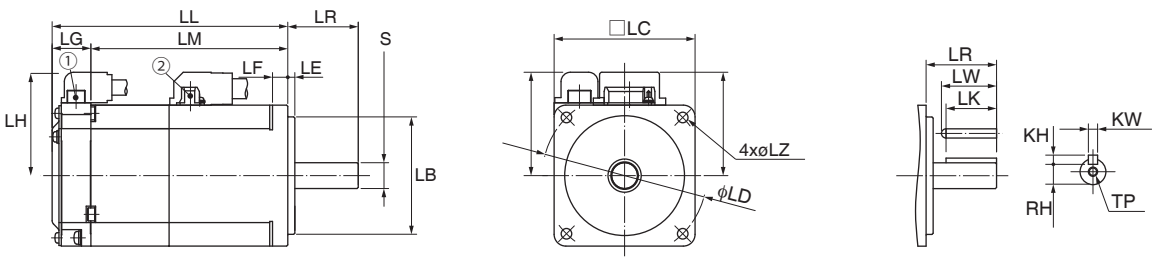

1000-1500W Side Front Key way dimensions

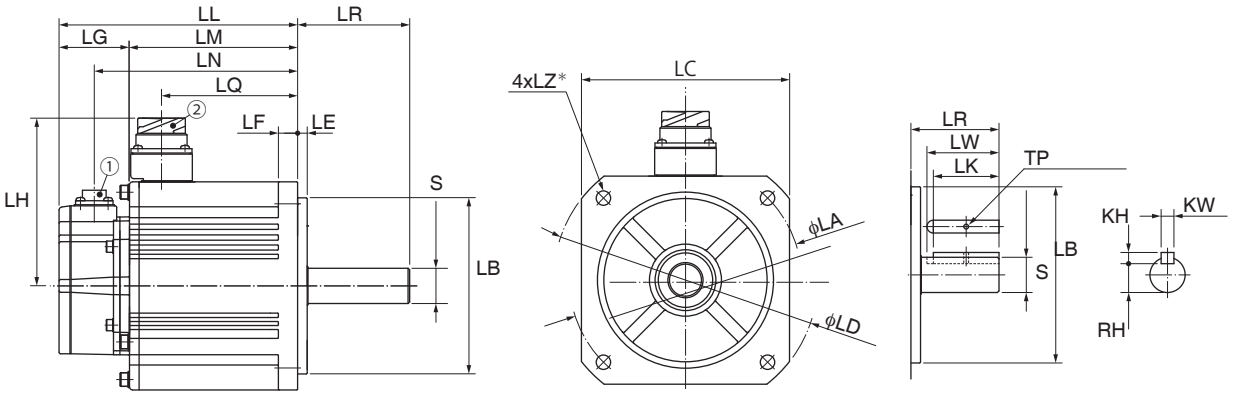

1) Encoder connector (JN2)
 2) Motor/brake connector
 Note: All illustrations show motors with holding brake.

MHMF (high inertia moment) 50–1500W, 200V AC

Rated power		W	50	100	200	400	750	1000		1500
Servo motor		200V AC	MHMF5AZL1□□	MHMF012L1□□	MHMF022L1□□	MHMF042L1□□	MHMF082L1□□	MHMF092L1□□	MHMF102L1□□	MHMF152L1□□
Encoder		ppr	23-bit absolute, 8388608							
LL	Without holding brake*	mm	57.5	71.5	71	88	95.4	108.2	-	-
	Without holding brake	mm	53.5	67.5	67.5	84.5	91.9	104.7	149	163
	With holding brake*	mm	91.4	105.4	100.3	117.3	129	141.8	-	-
	With holding brake	mm	87.4	101.4	96.8	113.8	125.5	138.3	177	191
LR		mm	25	25	30	30	35	35	70	70
LG		mm	16.6	16.6	16.5	16.5	16.5	16.5	44	44
LM	Without holding brake*	mm	40.9	54.9	54.5	71.5	78.9	91.7	-	-
	Without holding brake	mm	36.9	50.9	51	68	75.4	88.2	105	119
	With holding brake*	mm	74.8	88.8	83.8	100.8	112.5	125.3	-	-
	With holding brake	mm	70.8	84.8	80.3	97.3	109	121.8	133	147
LN	Without holding brake	mm	-	-	-	-	-	-	127	141
	With holding brake	mm	-	-	-	-	-	-	155	169
LQ	Without holding brake	mm	-	-	-	-	-	-	85	99
	With holding brake	mm	-	-	-	-	-	-	71	83
LH	Without holding brake	mm	34.5	34.5	44	44	54	54	85	105
	With holding brake	mm	34.5	34.5	44	44	54	54	71	116
LF		mm	5	5	6.5	6.5	8	8	12	12
LE		mm	3	3	3	3	3	3	6	-
S		mm	∅ 8 h6	∅ 8 h6	∅ 11 h6	∅ 14 h6	∅ 19 h6	∅ 19 h6	∅ 22 h6	∅ 22 h6
LB		mm	∅ 30 h7	∅ 30 h7	∅ 50 h7	∅ 50 h7	∅ 70 h7	∅ 70 h7	∅ 110 h7	∅ 110 h7
LC		mm	□40	□40	□60	□60	□80	□80	□130	□130
LZ		mm	2 x ∅ 4.3	2 x ∅ 4.3	4 x ∅ 4.5	4 x ∅ 4.5	4 x ∅ 6	4 x ∅ 6	4 x ∅ 9	4 x ∅ 9
LA		mm	∅ 46 ±0.2	∅ 46 ±0.2	∅ 70 ±0.2	∅ 70 ±0.2	∅ 90 ±0.2	∅ 90 ±0.2	∅ 145	∅ 145
LD		mm	-	-	-	-	-	-	∅ 165	∅ 165
Key way	LW	mm	14	14	20	20.5	25	25	45	45
	LK	mm	12.5	12.5	18	18	22	22	41	41
	KW	mm	3 h9	3 h9	4 h9	5 h9	6 h9	6 h9	8 h9	8 h9
	KH	mm	3	3	4	5	6	6	7	7
	RH	mm	6.2	6.2	8.5	11	15.5	15.5	18	18
	TP	mm	M3, depth 6	M3, depth 6	M4, depth 8	M5, depth 10	M5, depth 10	M5, depth 10	M3, through-hole	M3, through-hole
Weight	Without holding brake	kg	0.31	0.42	0.78	1.2	2.3	2.8	6.1	7.7
	With holding brake	kg	0.53	0.64	1.2	1.6	3	3.5	7.6	9.2

□□ Motor type, see brochure *Servo drives 4247euen* page 20

* With oil seal

400V AC

MSMF (low inertia moment) 1kW–5kW, 400V AC

1kW–5kW Side

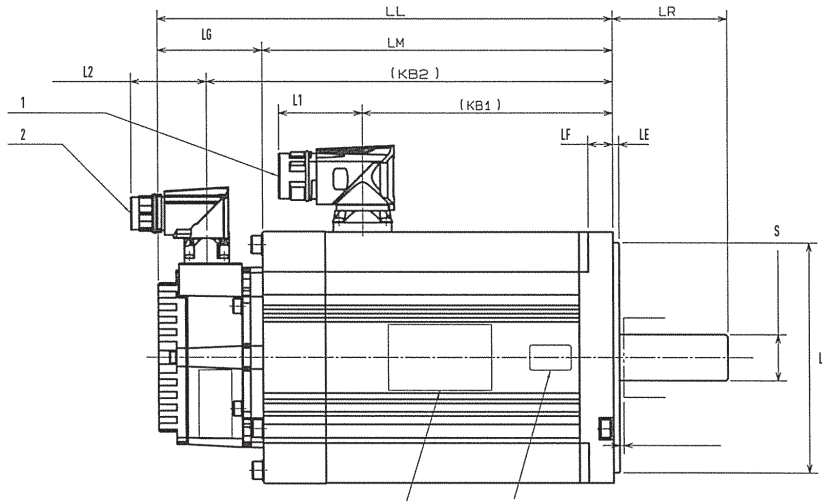

1kW–5kW Front Key way dimensions

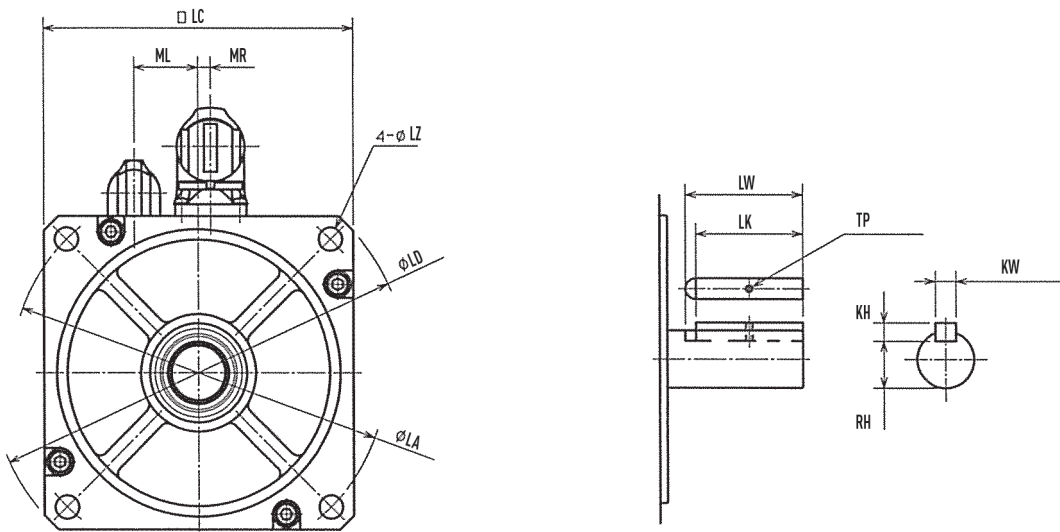

MSMF (low inertia moment) 1kW–5kW, 400V AC

Rated power		W	1000	1500	2000	3000	4000	5000
Encoder		ppr	23-bit, 8388608					
LR		mm	55	55	55	55	65	65
LM	Without holding brake	mm	95	113.5	132.5	144	163	198
	With holding brake	mm	122	140.5	159.5	169	191	226
LN / KB2	Without holding brake	mm	122	140.5	159.5	171	190	225
	With holding brake	mm	149	167.5	186.5	196	218	253
LQ / KB1	Without holding brake	mm	62	80.5	99.5	121	139	174
	With holding brake	mm	62	80.5	99.5	121	139	174
L1		mm	40	40	40	40	40	40
L2		mm	36.2	36.2	36.2	36.2	36.2	36.2
LF		mm	10	10	10	12	12	12
LE		mm	3	3	3	3	6	6
S		mm	∅ 19 h6	∅ 19 h6	∅ 19 h6	∅ 22 h6	∅ 24 h6	∅ 24 h6
LB		mm	∅ 95 h7	∅ 95 h7	∅ 95 h7	∅ 110 h7	∅ 110 h7	∅ 110 h7
LC		mm	∅ 100	∅ 100	∅ 100	∅ 120	∅ 130	∅ 130
LZ		mm	4 x ∅ 9	4 x ∅ 9	4 x ∅ 9	4 x ∅ 9	4 x ∅ 9	4 x ∅ 9
LA		mm	∅ 115	∅ 115	∅ 115	∅ 145	∅ 145	∅ 145
LD		mm	∅ 135	∅ 135	∅ 135	∅ 162	∅ 165	∅ 165
ML		mm	25	25	25	25	25	25
MR		mm	5	5	5	5	5	5
Key way	LW	mm	45	45	45	45	55	55
	LK	mm	42	42	42	41	51	51
	KW	mm	6 h9	6 h9	6 h9	8 h9	8 h9	8 h9
	KH	mm	6	6	6	7	7	7
	RH	mm	15.5	15.5	15.5	18	20	20
	TP	mm	M3, through-hole	M3, through-hole	M3, through-hole	M3, through-hole	M3, through-hole	M3, through-hole
Weight	Without holding brake	kg	3.6	4.6	5.6	8.7	11.5	14.5
	With holding brake	kg	4.7	5.6	6.6	9.9	13.2	16.1
Servo motor (standard)		400V AC	MSMF104L100M	MSMF154L100M	MSMF204L100M	MSMF304L100M	MSMF404L100M	MSMF504L100M
LL	Without holding brake	mm	139	157.5	176.5	194.5	213.5	248.5
	With holding brake	mm	166	184.5	203.5	219.5	241.5	276.5
LG		mm	44	44	44	44	44	44
Servo motor (battery-free encoder)		400V AC	MSMF104A100M	MSMF154A100M	MSMF204A100M	MSMF304A100M	MSMF404A100M	MSMF504A100M
LL	Without holding brake	mm	145.5	164	183	188	207	242
	With holding brake	mm	172.5	191	210	213	235	270
LG		mm	50.5	50.5	50.5	50.5	50.5	50.5

□□ Motor type, see brochure *Servo drives 4247eu*en page 22

MDMF (medium inertia moment) 1kW–5kW, 400V AC

Rated power		W	1000	1500	2000	3000	4000	5000
Encoder		ppr	23-bit, 8388608					
LR		mm	55	55	55	56	70	70
LM	Without holding brake	mm	77	91	105	133	119	134
	With holding brake	mm	105	119	133	161	148	163
LN / KB2	Without holding brake	mm	104	118	132	160	146	161
	With holding brake	mm	132	146	160	188	175	190
LQ / KB1	Without holding brake	mm	53	67	81	109	94	109
	With holding brake	mm	53	67	81	109	94	109
L1		mm	40	40	40	40	40	40
L2		mm	36.2	36.2	36.2	36.2	36.2	36.2
LF		mm	12	12	12	12	18	18
LE		mm	6	6	6	6	3.2	3.2
S		mm	∅ 22 h6	∅ 22 h6	∅ 22 h6	∅ 24 h6	∅ 35 h6	∅ 35 h6
LB		mm	∅ 110 h7	∅ 110 h7	∅ 110 h7	∅ 110 h7	∅ 114.3 h7	∅ 114.3 h7
LC		mm	∅ 130	∅ 130	∅ 130	∅ 130	∅ 176	∅ 176
LZ		mm	4 x ∅ 9	4 x ∅ 9	4 x ∅ 9	4 x ∅ 9	4 x ∅ 13.5	4 x ∅ 13.5
LA		mm	∅ 145	∅ 145	∅ 145	∅ 145	∅ 200	∅ 200
LD		mm	∅ 165	∅ 165	∅ 165	∅ 165	∅ 233	∅ 233
ML		mm	25	25	25	25	-	-
MR		mm	5	5	5	5	-	-
Key way	LW	mm	45	45	45	55	55	55
	LK	mm	41	41	41	51	50	50
	KW	mm	8 h9	8 h9	8 h9	8 h9	10 h9	10 h9
	KH	mm	7	7	7	7	8	8
	RH	mm	18	18	18	20	30	30
	TP	mm	M3, through-hole	M3, through-hole	M3, through-hole	M3, through-hole	M3, through-hole	M3, through-hole
Weight	Without holding brake	kg	4.6	5.7	6.9	9.3	13.4	15.6
	With holding brake	kg	6.1	7.2	8.4	10.9	16.8	19
Servo motor (standard)		400V AC	MDMF104L1□□M	MDMF154L1□□M	MDMF204L1□□M	MDMF304L1□□M	MDMF404L1□□M	MDMF504L1□□M
LL	Without holding brake	mm	121	135	149	177	163	178
	With holding brake	mm	149	163	177	205	192	207
LG		mm	44	44	44	44	44	44
Servo motor (battery-free encoder)		400V AC	MDMF104A1□□M	MDMF154A1□□M	MDMF204A1□□M	MDMF304A1□□M	MDMF404A1□□M	MDMF504A1□□M
LL	Without holding brake	mm	127.5	141.5	155.5	183.5	169.5	184.5
	With holding brake	mm	155.5	169.5	183.5	211.5	198.5	213.5
LG		mm	50.5	50.5	50.5	50.5	50.5	50.5

□□ Motor type, see brochure *Servo drives 4247eu*en page 22

MHMF (high inertia moment) 1kW-5kW, 400V AC

1kW-1.5kW Side Front

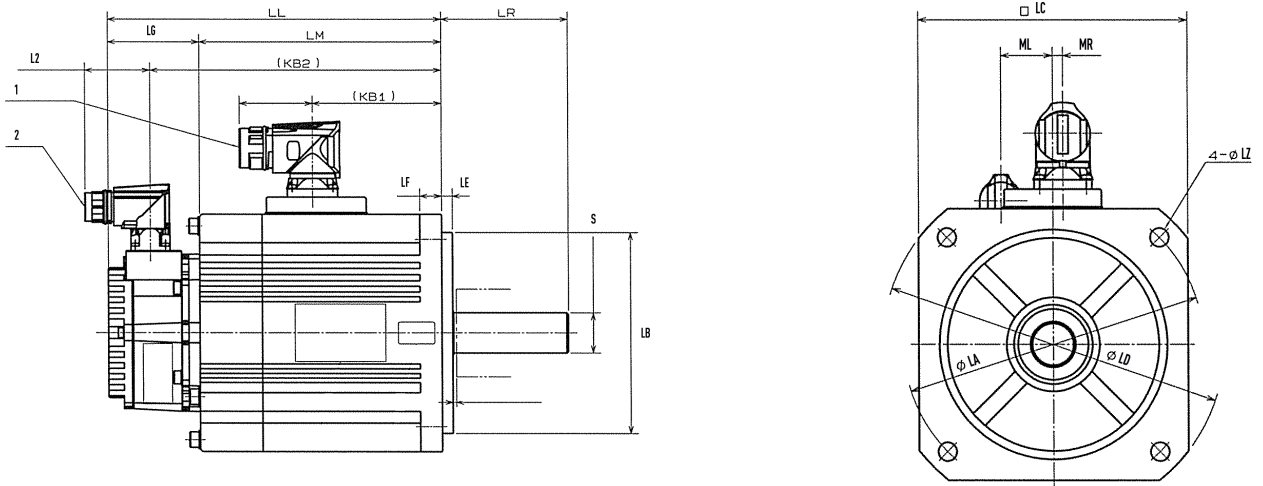

1kW-1.5kW Key way dimensions

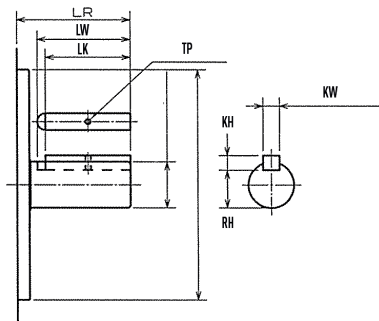

2kW-5kW Side Front Key way dimensions

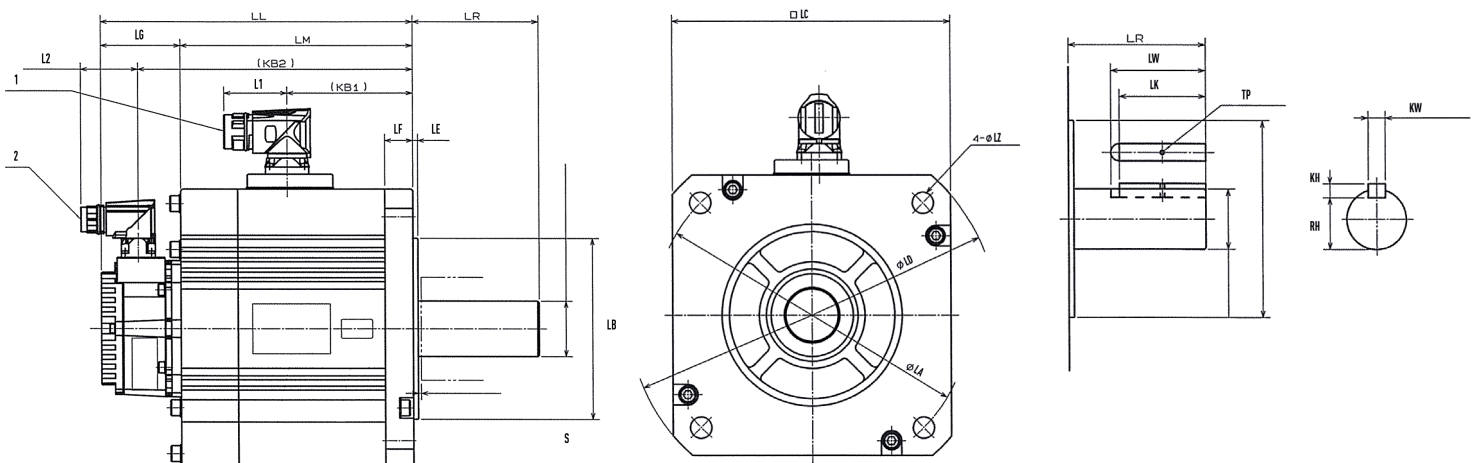

MHMF (high inertia moment) 1kW–5kW, 400V AC

Rated power		W	1000	1500	2000	3000	4000	5000
Encoder		ppr	23-bit, 8388608					
LR		mm	70	70	80	80	80	80
LM	Without holding brake	mm	105	119	119	134	148.5	164.5
	With holding brake	mm	133	147	148	163	177.5	193.5
LN / KB2	Without holding brake	mm	132	146	146	161	175.5	191.5
	With holding brake	mm	160	174	175	190	204.5	220.5
LQ / KB1	Without holding brake	mm	71	85	80.5	95.5	110	126
	With holding brake	mm	71	85	80.5	95.5	110	126
L1		mm	40	40	40	40	40	40
L2		mm	36.2	36.2	36.2	36.2	36.2	36.2
LF		mm	12	12	18	18	18	18
LE		mm	6	6	3.2	3.2	3.2	3.2
S		mm	∅ 22 h6	∅ 22 h6	∅ 35 h6	∅ 35 h6	∅ 35 h6	∅ 35 h6
LB		mm	∅ 110 h7	∅ 110 h7	∅ 114.3 h7	∅ 114.3 h7	∅ 114.3 h7	∅ 114.3 h7
LC		mm	∅ 130	∅ 130	∅ 176	∅ 176	∅ 176	∅ 176
LZ		mm	4 x ∅ 9	4 x ∅ 9	4 x ∅ 13.5	4 x ∅ 13.5	4 x ∅ 13.5	4 x ∅ 13.5
LA		mm	∅ 145	∅ 145	∅ 200	∅ 200	∅ 200	∅ 200
LD		mm	∅ 165	∅ 165	∅ 233	∅ 233	∅ 233	∅ 233
ML		mm	25	25	-	-	-	-
MR		mm	5	5	-	-	-	-
Key way	LW	mm	45	45	55	55	55	55
	LK	mm	41	41	50	50	50	50
	KW	mm	8 h9	8 h9	10 h9	10 h9	10 h9	10 h9
	KH	mm	7	7	8	8	8	8
	RH	mm	18	18	30	30	30	30
	TP	mm	M3, through-hole	M3, through-hole	M3, through-hole	M3, through-hole	M3, through-hole	M3, through-hole
Weight	Without holding brake	kg	6.1	7.7	11.3	13.8	16.2	19.6
	With holding brake	kg	7.6	9.2	14.6	17.2	19.4	22.8
Servo motor (standard)		400V AC	MHMF104L1∞M	MHMF154L1∞M	MHMF204L1∞M	MHMF304L1∞M	MHMF404L1∞M	MHMF504L1∞M
LL	Without holding brake	mm	149	163	163	178	192.5	208.5
	With holding brake	mm	177	191	192	207	221.5	237.5
LG		mm	44	44	44	44	44	44
Servo motor (battery-free encoder)		400V AC	MHMF104A1∞M	MHMF154A1∞M	MHMF204A1∞M	MHMF304A1∞M	MHMF404A1∞M	MHMF504A1∞M
LL	Without holding brake	mm	155.5	169.5	169.5	184.5	199	215
	With holding brake	mm	183.5	197.5	198.5	213.5	228	244
LG		mm	50.5	50.5	50.5	50.5	50.5	50.5

□□ Motor type, see brochure *Servo drives 4247eu*en page 22