

# PM SERIES

## U-shaped Micro Photoelectric Sensor

MS-AJ  
Sensor Mounting Stand

PM

Micro

PM2

NX5  
Multi-voltage Type

VF

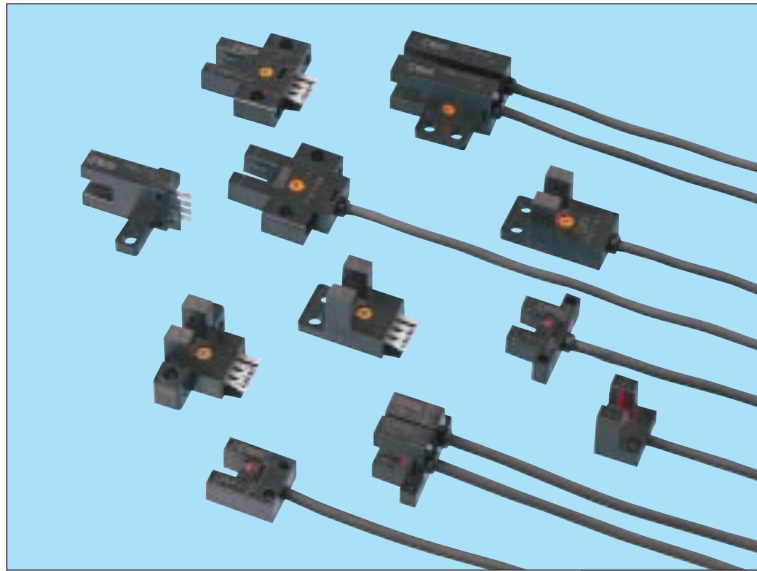
SU-7/SH  
Amplifier-separated TypeSS-A5  
Amplifier-separated TypeCHX-SC2  
Sensor Checker

**Extremely Small Size  
Enables Space Saving  
and Quick Installation!**

**CE Marked**  
Conforming to EMC Directive

### Extremely Small

Ultra-small type **PM-□24(-R)** contributes to the miniaturization of your equipment. Even the small cable type has become very compact.

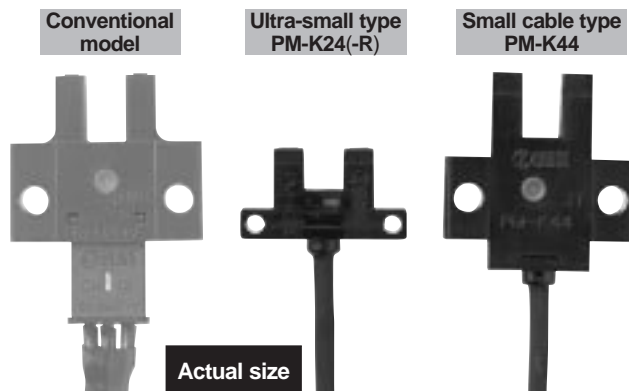

### Equipped with Two Independent Outputs

All models are equipped with two independent outputs – Light-ON and Dark-ON. Hence, one model suffices even if the output is to be used differently, depending upon the location of use.

Also, since two independent outputs have been provided, cumbersome handling of the output conversion control input, or fear of logic inversion due to a cable break, is eliminated. The sensor can be connected to the existing wiring as it is.

#### Example of connection with a commercial intermediate connector

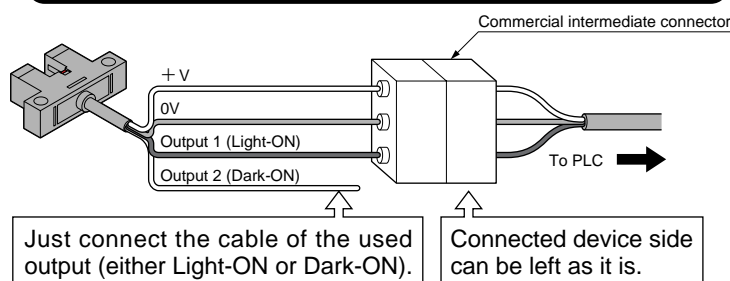

Note: Ensure to insulate the unused output wire.

### Quick Fitting Hook-up Connector

Easy to maintain connector type models are available. Its exclusive connector is the industry's first hook-up connector. Since only crimping with exclusive pliers is to be done, cumbersome soldering or insulation is absolutely not required. Further, connector attached cable is also available.

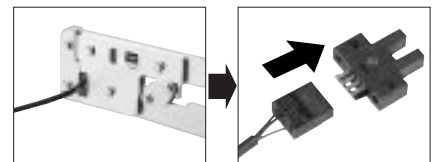

Crimp the connector on the cable.

Quick connection to the sensor.

### Wide Model Variety

A wide variety of 17 shapes and 29 models is available. You may select from this wide range to suit the mounting conditions.

### Meets Global Requirements

Conforms to Europe's EMC Directive. Both, NPN and PNP output models are available.

## APPLICATIONS

### Sensing the starting point on a rotating body

The starting point can be sensed by making a slit in the rotating body.

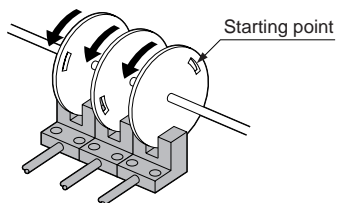

### Determining the pallet position

Pallet is stopped by sensing the dog.

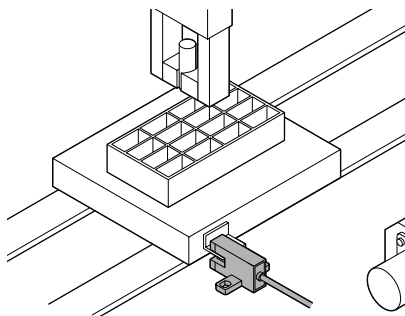

### Sensing the starting point and overrun of a moving body

Starting point and overrun is sensed using the dog on the base.

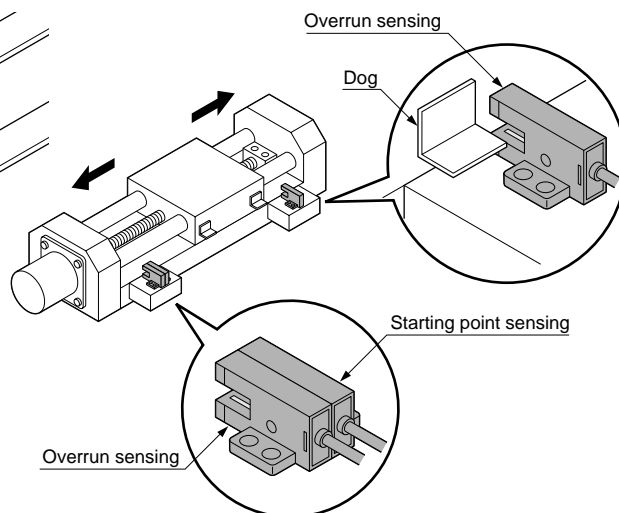

## ORDER GUIDE

Type	Appearance (mm)	Sensing range	Model No. (Note)	Output	Output operation
Ultra-small		5mm (fixed)	PM-K24	NPN open-collector transistor	Incorporated with 2 outputs: Light-ON/Dark-ON
			PM-K24-R		
			PM-L24		
			PM-L24-R		
			PM-F24		
			PM-F24-R		
			PM-R24		
			PM-R24-R		
			PM-U24		
			PM-U24-R		

Note: The suffix '-R' indicates a inflection resistant cable type.

Sensor Mounting Stand  
MS-AJ

PM

Micro  
PM2

Multi-voltage Type  
NX5

VF

Amplifier-separated Type  
SU-7/SH

SS-A5

Sensor Checker  
CHX-SC2

## ORDER GUIDE

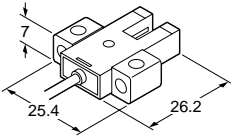
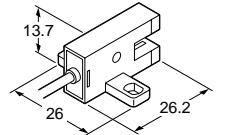
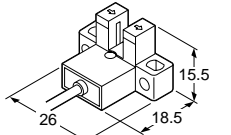
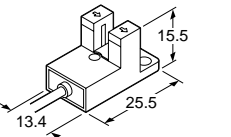
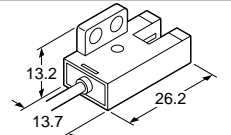
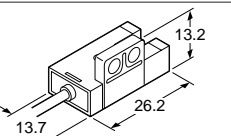
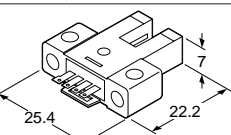
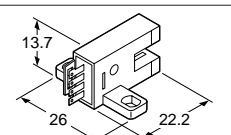
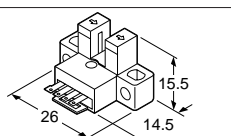
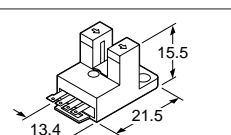
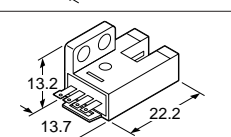
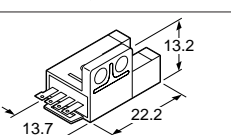
Type	Appearance (mm)	Sensing range	Model No.	Output	Output operation				
Small	With cable	5mm (fixed)	K type		<b>PM-K44</b>	NPN open-collector transistor			
					<b>PM-K44P</b>	PNP open-collector transistor			
			T type		<b>PM-T44</b>	NPN open-collector transistor			
					<b>PM-T44P</b>	PNP open-collector transistor			
			L type		<b>PM-L44</b>	NPN open-collector transistor			
					<b>PM-L44P</b>	PNP open-collector transistor			
			Y type		<b>PM-Y44</b>	NPN open-collector transistor			
					<b>PM-Y44P</b>	PNP open-collector transistor			
			F type		<b>PM-F44</b>	NPN open-collector transistor			
					<b>PM-F44P</b>	PNP open-collector transistor			
			R type		<b>PM-R44</b>	NPN open-collector transistor			
					<b>PM-R44P</b>	PNP open-collector transistor			
			Small	With connector	5mm (fixed)	K type		<b>PM-K54</b>	NPN open-collector transistor
								<b>PM-K54P</b>	PNP open-collector transistor
T type		<b>PM-T54</b>				NPN open-collector transistor			
		<b>PM-T54P</b>				PNP open-collector transistor			
L type		<b>PM-L54</b>				NPN open-collector transistor			
		<b>PM-L54P</b>				PNP open-collector transistor			
Y type		<b>PM-Y54</b>				NPN open-collector transistor			
		<b>PM-Y54P</b>				PNP open-collector transistor			
F type		<b>PM-F54</b>				NPN open-collector transistor			
		<b>PM-F54P</b>				PNP open-collector transistor			
R type		<b>PM-R54</b>				NPN open-collector transistor			
		<b>PM-R54P</b>				PNP open-collector transistor			

Incorporated with 2 outputs: Light-ON/Dark-ON

## OPTIONS

Designation	Model No.	Description	
Connector	<b>CN-14</b>	Connector for soldering	
Hook-up connector	<b>CN-14H</b>	This connector can be hooked-up on 0.08 to 0.2mm <sup>2</sup> cable simply in one grip. Wire diameter: $\phi$ 0.7 to $\phi$ 1.2mm	
	<b>CN-14H-2</b>	Suitable for UL standard cable. This connector can be hooked-up on 0.18 to 0.22mm <sup>2</sup> cable simply in one grip. Wire diameter: $\phi$ 1.2 to $\phi$ 1.52mm	
Connector attached cable	<b>CN-14H-C1</b>	Length: 1m	For the connector type, with 0.18mm <sup>2</sup> 4-core cabtyre cable Cable diameter: $\phi$ 3.8mm
	<b>CN-14H-C3</b>	Length: 3m	
Hook-up pliers	<b>CN-HP</b>	These are exclusive pliers for hook-up connectors <b>CN-14H</b> and <b>CN-14H-2</b> .	
Mounting screw	<b>MS-M2</b>	Mounting screw with washers for the ultra-small type sensor (50 Nos. lot). It can mount securely as it is spring washer attached.	

Connector

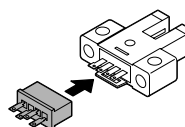

Hook-up connector

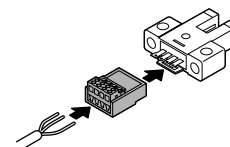

Connector attached cable

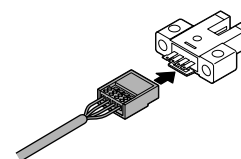

Hook-up pliers

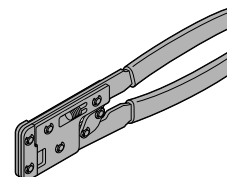

Mounting screw



Sensor Mounting Stand  
**MS-AJ**

Micro  
**PM**

**PM2**

Multi-voltage Type  
VF  
NX5

Amplifier-separated Type  
SU-7/SH

SS-A5

Sensor Checker  
CHX-SC2

## SPECIFICATIONS

Item	Model No.	Type	Ultra-small		Small	
			NPN output type	With inflection resistant cable	With cable	With connector
PNP output type				PM-□44P	PM-□54P	
Sensing range		5mm (fixed)				
Minimum sensing object		0.8 × 1.8mm opaque object				
Hysteresis		0.05mm or less				
Repeatability		0.03mm or less				
Supply voltage		5 to 24V DC ± 10% Ripple P-P 10% or less				
Current consumption		15mA or less				
Output		<NPN output type> NPN open-collector transistor <ul style="list-style-type: none"> <li>• Maximum sink current: 50mA</li> <li>• Applied voltage: 30V DC or less (between output and 0V)</li> <li>• Residual voltage: 0.7V or less (at 50mA sink current) 0.4V or less (at 16mA sink current)</li> </ul>		<PNP output type> PNP open-collector transistor <ul style="list-style-type: none"> <li>• Maximum source current: 50mA</li> <li>• Applied voltage: 30V DC or less (between output and +V)</li> <li>• Residual voltage: 0.7V or less (at 50mA source current) 0.4V or less (at 16mA source current)</li> </ul>		
Utilization category		DC-12 or DC-13				
Output operation		Incorporated with 2 outputs: Light-ON/Dark-ON				
Response time		Under light received condition: 20 μs or less Under light interrupted condition: 100 μs or less (Response frequency: 1kHz or more)(Note 1)				
Operation indicator		Vermilion LED (lights up under light received condition)				
Pollution degree		3 (Industrial environment)				
Ambient temperature (Note 2, 3)		- 25 to + 55°C (No dew condensation or icing allowed), Storage: - 30 to + 80°C				
Ambient humidity		35 to 85% RH, Storage: 35 to 85% RH				
Ambient illuminance		Fluorescent light: 1,000 lx at the light-receiving face				
EMC		Emission: EN50081-2, Immunity: EN50082-2				
Voltage withstandability		1,000V AC for one min. between all supply terminals connected together and enclosure				
Insulation resistance		50MΩ, or more, with 250V DC megger between all supply terminals connected together and enclosure				
Vibration resistance		10 to 2,000Hz frequency, 1.5mm amplitude in X, Y and Z directions for two hours each				
Shock resistance		15,000m/s <sup>2</sup> acceleration (1,500G approx.) in X, Y and Z directions for three times each				
Emitting element		Infrared LED (non-modulated)				
Material		Enclosure: PBT, Slit cover: Polycarbonate, Terminal part [PM-□54(P) only]: Solder plated				
Cable		0.09mm <sup>2</sup> 4-core cabtyre cable (PM-□24-R: 0.1mm <sup>2</sup> inflection, oil and heat resistant cabtyre cable), 1m long				
Cable extension		Extension up to total 100m is possible with 0.3mm <sup>2</sup> , or more, cable.				
Weight		10g approx.		15g approx.		3g approx.

Notes: 1) The response frequency is the value when the disc, given in the figure below, is rotated.

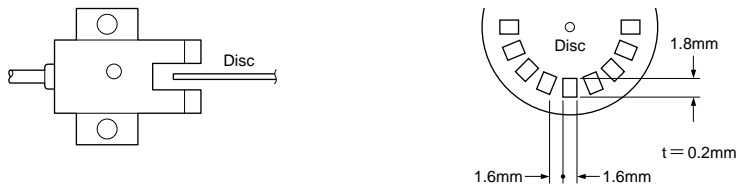

- 2) In case the ultra-small type PM-□24(-R) is used at an ambient temperature of + 50°C, or more, make sure to mount it on a metal body.
- 3) Take care that the flexibility of the PM-□24-R cable is lost if the ambient temperature is near - 10°C.

## I/O CIRCUIT AND WIRING DIAGRAMS

PM-□24 PM-□24-R  
PM-□44 PM-□54

NPN output type

### I/O circuit diagram

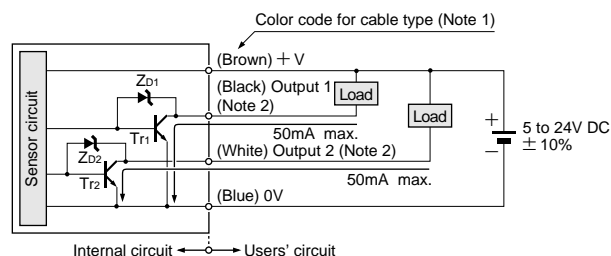

Notes: 1) The color code of the connector attached cable is also the same.  
2) Ensure to insulate the unused output wire.

Symbols ... ZD1, ZD2: Surge absorption zener diode  
Tr1, Tr2 : NPN output transistor

### Wiring diagram

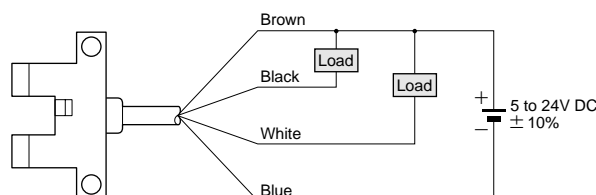

### Output operation

	Color code	Output operation
Output 1	Black	Light-ON
Output 2	White	Dark-ON

PM-□44P  
PM-□54P

PNP output type

### I/O circuit diagram

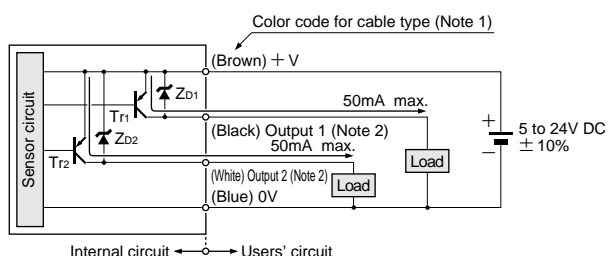

Notes: 1) The color code of the connector attached cable is also the same.  
2) Ensure to insulate the unused output wire.

Symbols ... ZD1, ZD2: Surge absorption zener diode  
Tr1, Tr2 : PNP output transistor

### Wiring diagram

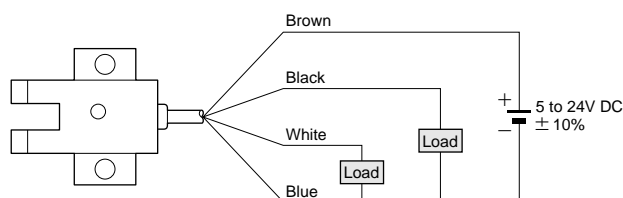

### Output operation

	Color code	Output operation
Output 1	Black	Light-ON
Output 2	White	Dark-ON

## PRECAUTIONS FOR PROPER USE

Refer to P.820~ for general precautions.

### All models



This product is not a safety sensor. Its use is not intended or designed to protect life and prevent body injury or property damage from dangerous parts of machinery. It is a normal object detection sensor.

### Wiring

- Please carry out the wiring carefully since protection circuits against reverse power supply connection and output short-circuit are not incorporated.

### Others

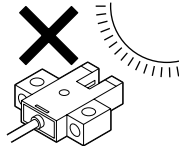
- Since the sensor is intended for use inside machines, no special countermeasures have been taken against extraneous light. Take care that extraneous light is not directly incident on the beam receiving section. 
- Do not use during the initial transient time (50ms) after the power supply is switched on.
- The cable of **PM-□24-R** is a flexible cable usable on a moving base. When the sensor is mounted on a moving base, fix the sensor cable joint so that stress is not applied to it.
- Take care that the flexibility of the **PM-□24-R** cable is lost if the ambient temperature is near  $-10^{\circ}\text{C}$ .

Sensor Mounting Stand  
MS-AJ

PM

Micro

PM2

Multi-voltage Type

NX5

VF

Amplifier-separated Type

SU-7/SH

Amplifier-separated Type

SS-A5

Sensor Checker

CHX-SC2

## PRECAUTIONS FOR PROPER USE

Refer to P.820~ for general precautions.

### All models

#### Mounting

- When fixing the sensor with screws, use M3 screws [M2 screws in case of **PM-□24(-R)**] and the tightening torque should not exceed the values given below. Further, use small, round type plain washers. (M3:  $\phi 6\text{mm}$ , M2:  $\phi 4.3\text{mm}$ )

Model No.	Tightening torque
PM-□24(-R)	0.15N·m
PM-□44(P)	0.5N·m
PM-□54(P)	

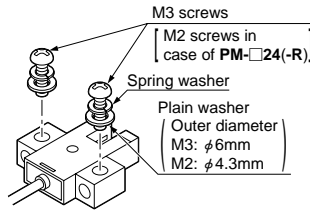

Note: In case the ultra-small type **PM-□24(-R)** is used at an ambient temperature of  $+50^{\circ}\text{C}$ , or more, make sure to mount it on a metal body.

#### Cable extension

- Cable extension is possible up to an overall length of 100m with a  $0.3\text{mm}^2$ , or more, cable. However, since a voltage drop shall occur due to the cable extension, ensure that the power supply voltage at the end of the cable attached to the sensor or at the sensor terminals is within the rating.

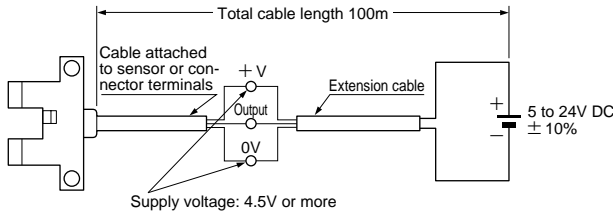

But, when the overall cable length, including the cable attached to the sensor, is as given below, there is no need to confirm the voltage.

Conductor cross-section area	Total cable length
0.08 to $0.1\text{mm}^2$	Up to 5m
$0.2\text{mm}^2$	Up to 10m
$0.3\text{mm}^2$	Up to 20m

## DIMENSIONS (Unit: mm)

### PM-K24 PM-K24-R Sensor

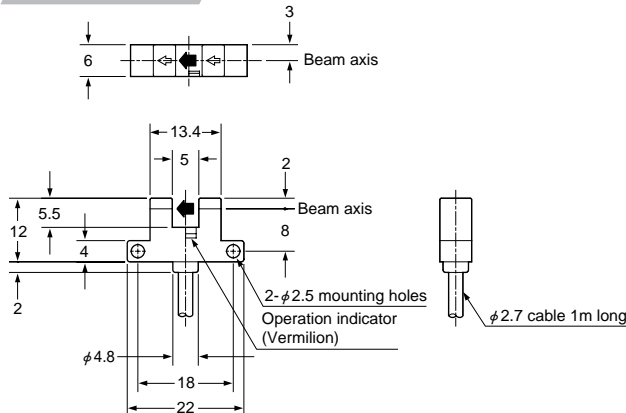

### PM-L24 PM-L24-R Sensor

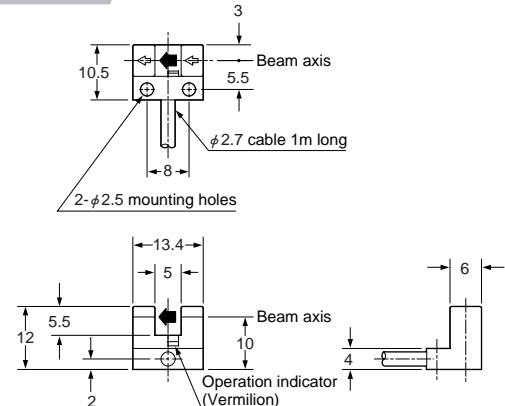

### PM-□54 PM-□54P

#### Crimping of hook-up connectors CN-14H and CN-14H-2

Item	Model No.	CN-14H	CN-14H-2
Conductor cross-section area		0.08 to $0.2\text{mm}^2$ (AWG28 to AWG24)	0.18 to $0.22\text{mm}^2$ (AWG25 to AWG24)
Wire diameter		$\phi 0.7$ to $\phi 1.2\text{mm}$	$\phi 1.2$ to $\phi 1.52\text{mm}$
Wire insulation material		Vinyl chloride or soft polyethylene	

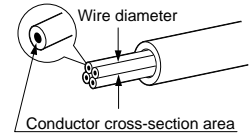

#### Crimping method

- Strip the cable sheath 15mm, or more, and insert the wires into the connector insertion holes till the wire tips reach the end.

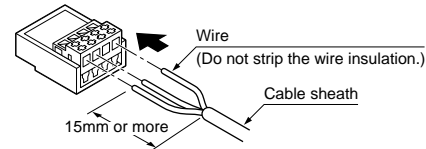

#### Arrangement of connector terminals

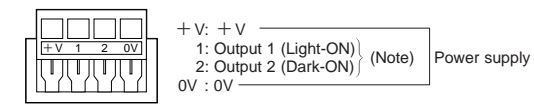

- Crimp with the exclusive hook-up pliers **CN-HP**.

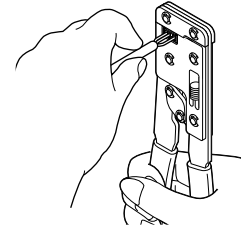

Caution: Make sure to use the exclusive hook-up pliers **CN-HP**. Commercially available pliers cannot be used.

#### Soldering

- If soldering is done directly on the terminals, strictly adhere to the conditions given below.

Item	Model No.	PM-□54(P)
Soldering temperature		260°C or less
Soldering time		3 sec. or less
Soldering position		Refer to the right figure

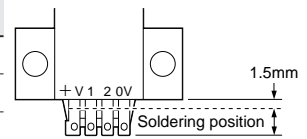

## DIMENSIONS (Unit: mm)

**PM-F24  
PM-F24-R** Sensor

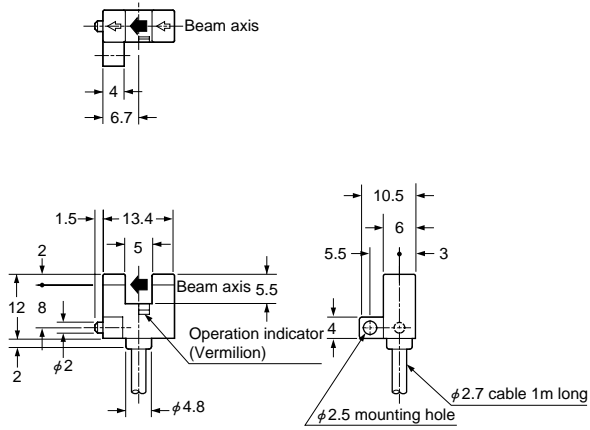

**PM-R24  
PM-R24-R** Sensor

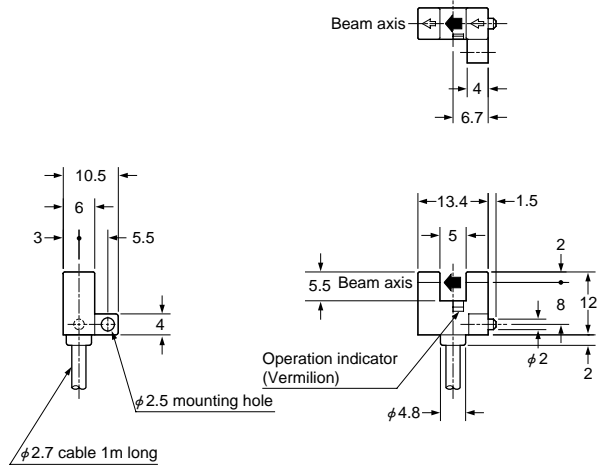

**PM-U24  
PM-U24-R** Sensor

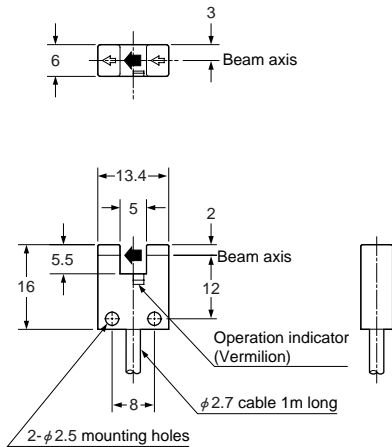

**PM-K44  
PM-K44P** Sensor

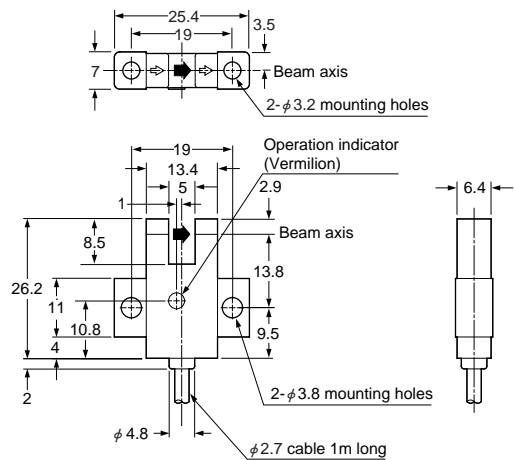

**PM-T44  
PM-T44P** Sensor

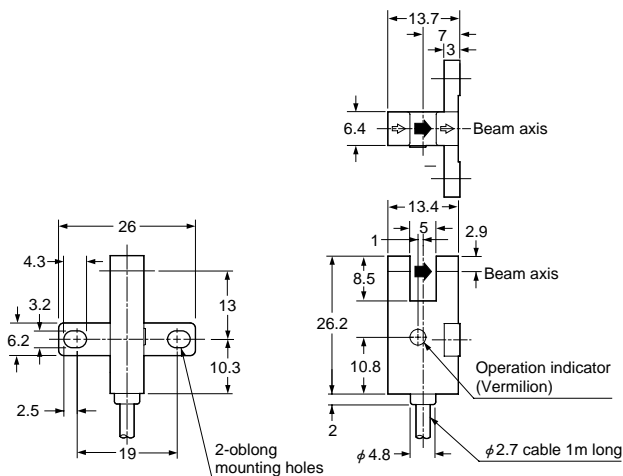

**PM-L44  
PM-L44P** Sensor

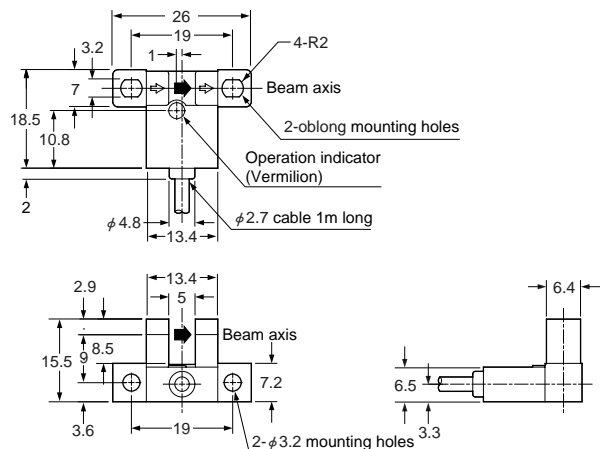

Sensor Mounting Stand  
**MS-AJ**

Micro  
**PM**  
PM2

Multi-voltage Type  
**NX5**  
VF

Amplifier-separated Type  
**SU-7/SH**

**SS-A5**

Sensor Checker  
**CHX-SC2**



## DIMENSIONS (Unit: mm)

**PM-Y44  
PM-Y44P** Sensor

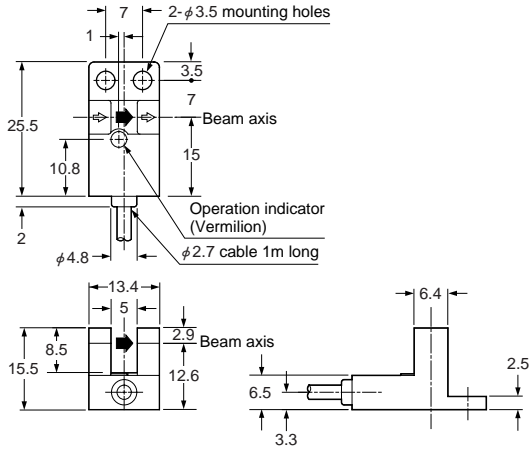

**PM-F44  
PM-F44P** Sensor

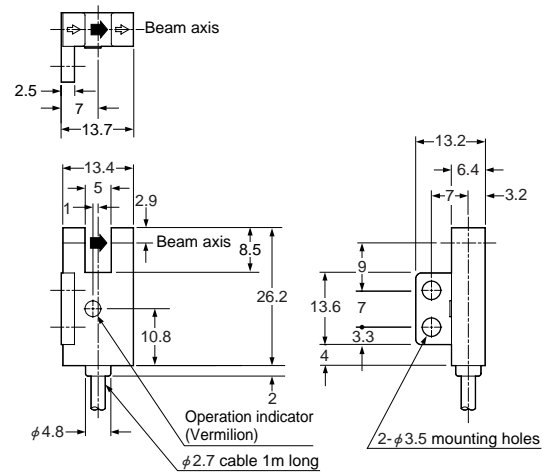

**PM-R44  
PM-R44P** Sensor

Sensor

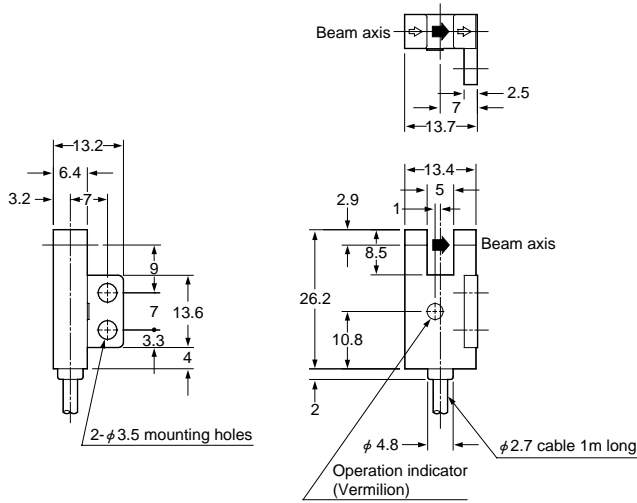

**PM-K54  
PM-K54P** Sensor

Sensor

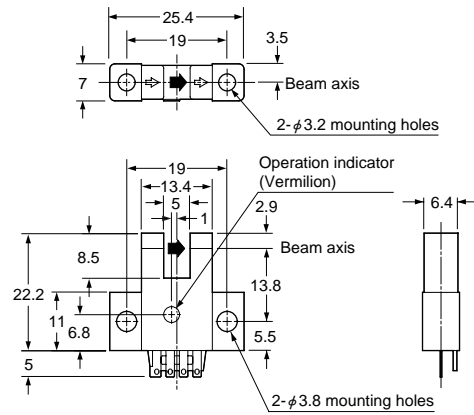

**PM-T54  
PM-T54P** Sensor

Sensor

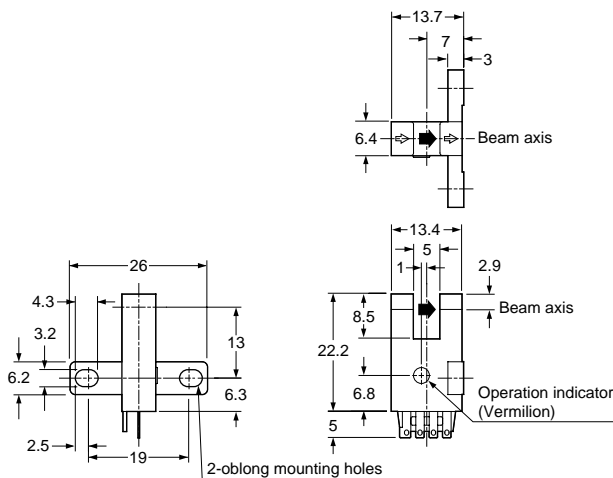

**PM-L54  
PM-L54P** Sensor

Sensor

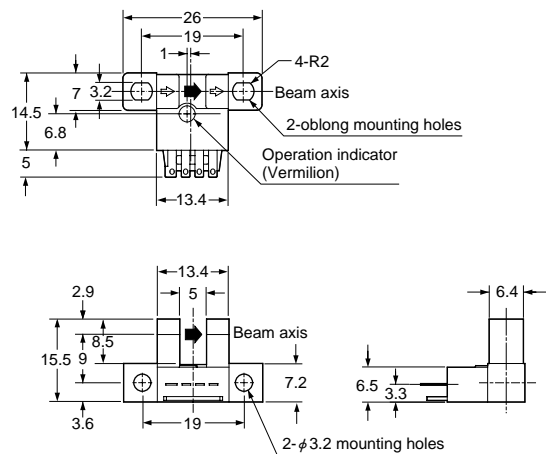

## DIMENSIONS (Unit: mm)

**PM-Y54  
PM-Y54P** Sensor

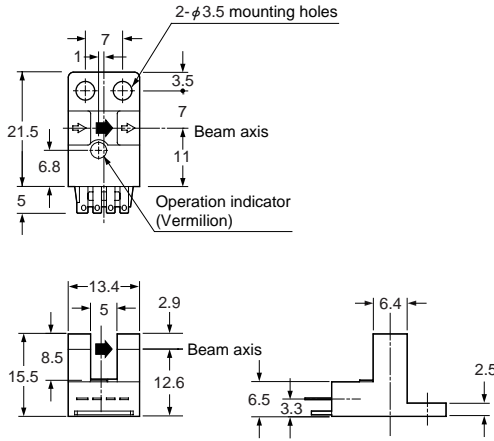

**PM-F54  
PM-F54P** Sensor

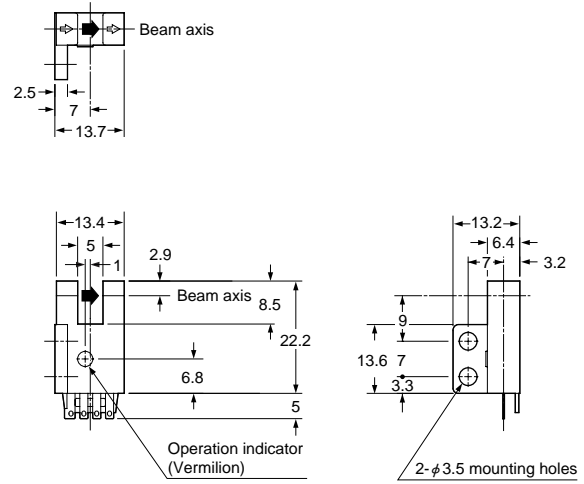

**PM-R54  
PM-R54P** Sensor

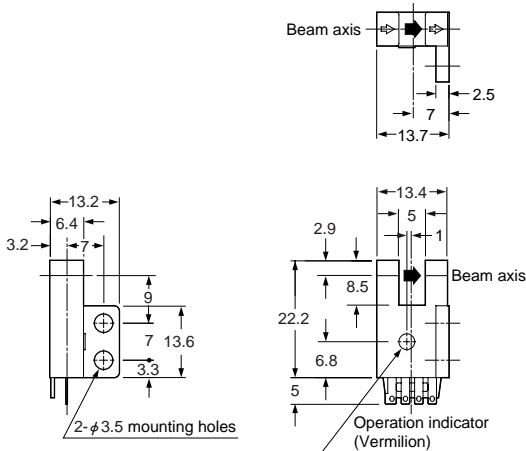

※Terminal part (PM-□54, PM-□54P)

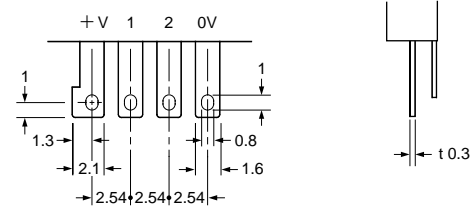

**CN-14H  
CN-14H-2** Hook-up connector (Optional)

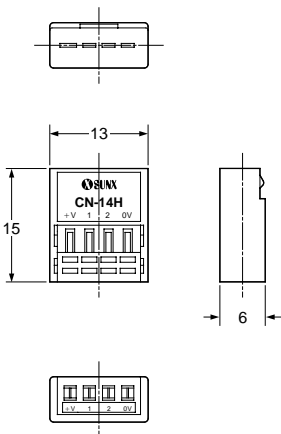

**CN-14** Connector (Optional)

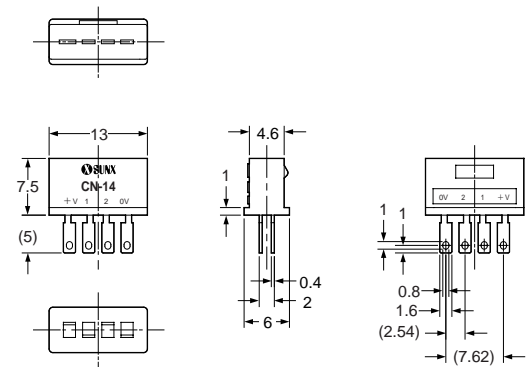

**CN-14H-C1  
CN-14H-C3** Connector attached cable (Optional)

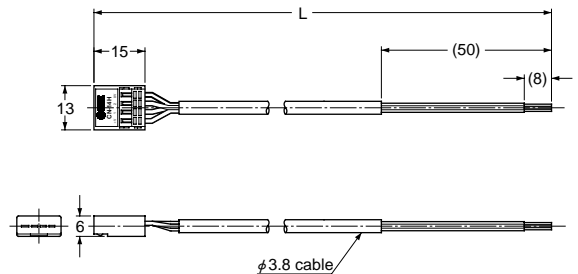

• Cable length L

Model No.	Cable length
CN-14H-C1	1m
CN-14H-C3	3m

Sensor Mounting Stand  
MS-AJ

Micro  
PM  
PM2

Multi-voltage Type  
NX5  
VF

Amplifier-separated Type  
SU-7/SH

SS-A5

Sensor Checker  
CHX-SC2