

Panasonic

ideas for life

Amplifier Built-in
ULTRA-COMPACT LASER SENSOR

EX-L200 SERIES

CE
Conforming to
EMC Directive

FDA
Conforming to
FDA regulations

Unrivaled



world smallest*
Self-Contained High Precision Laser Sensor

* Based on research conducted by our company as of January 2012

Introducing world smallest* amplifier built-in laser sensor

Due to the customized IC and optical design, high precision detection is fulfilled in a world smallest size with directivity and visibility achievable only by laser.

The laser adopted is Class 1 (JIS / IEC / FDA) laser that is safe to use, so that there is no need to separate the areas of sensor usage.

* Based on research conducted by our company as of January 2012

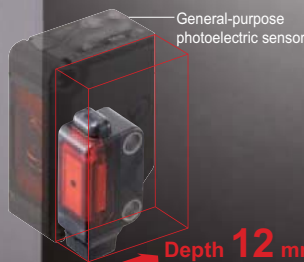

General-purpose photoelectric sensor

Depth **12 mm**
0.472 in

W8.2 × H23.4 × D12 mm
W0.323 × H0.921 × D0.472 in
(Thru-beam type)

Thru-beam type (EX-L211, EX-L212)

Minute object detection type (EX-L211)

The beam is purposely widened to have a lower beam density and little beam spread so that when detecting minute objects, even a slight change in the light received intensity will not be missed.

Spot size: 6 × 4 mm 0.236 × 0.157 in approx.

(Visual reference value at a sensing distance of 1 m 3.281 ft)

Long sensing range type (EX-L212)

A long range detection of 3 m 9.843 ft is achieved. High precision detection with minimum beam spread is possible even in a long range.

Spot size: 8 × 5.5 mm 0.315 × 0.217 in approx.

(Visual reference value at a sensing distance of 1 m 3.281 ft)

Sensing range

Minute object detection type (EX-L211):

1 m 3.281 ft

Long sensing range type (EX-L212):

3 m 9.843 ft

Reflective type (EX-L291)

Long sensing range type

Achieving ease of installation and 4 m 13.123 ft long sensing range.

Spot size: 6 × 4 mm 0.236 × 0.157 in approx.

(Visual reference value at a sensing distance of 1 m 3.281 ft)

Sensing range

4 m 13.123 ft

Spot reflective type (EX-L221)

Minute object detection type

Highly precise sensing with minimum 0.01 mm 0.0004 in diameter.

Many applications are possible due to the 300 mm 11.811 in long sensing range.

Spot size: ø1 mm ø0.039 in

(Visual reference value at a sensing distance of 300 mm 11.811 in)

Sensing range

45 mm to 300 mm

1.772 in to 11.811 in

Convergent reflective type (EX-L261, EX-L262) **NEW**

Spot type (EX-L261)

Highly precise sensing with minimum 0.01 mm 0.0004 in diameter.

Not affected by the background, and able to reliably sense unevenly-colored workpieces.

Spot size: ø1 mm ø0.039 in

(Visual reference value at a sensing distance of 50 mm 1.969 in)

Sensing range

Spot type (EX-L261):

20 mm to 50 mm

0.787 in to 1.969 in

Line spot type (EX-L262)

Able to sense thin, glossy or curved-surface workpieces due to line beam.

Spot size: 1 × 5 mm 0.039 × 0.197 in approx.

(Visual reference value at a sensing distance of 50 mm 1.969 in)

Sensing range

Line spot type (EX-L262):

20 mm to 70 mm

0.787 in to 2.756 in

15/06/2012

Minute object detection type (EX-L211, EX-L221)

Highly accurate detection

- **Suitable for positioning and minute object detection**

A repeatability of 0.02 mm **0.0008 in** or less at a range of from 100 to 200 mm **3.937 to 7.874 in** makes this type best suitable for positioning applications (EX-L221).

Moreover, it boasts a top-class detection precision in the compact laser sensor category with the gold wire of $\varnothing 0.01$ mm **$\varnothing 0.0004$ in**.

Model No. (Minute object detection type)	Minimum sensing object (Typical)	Repeatability (Typical)
EX-L211 (Thru-beam type)	$\varnothing 0.3$ mm $\varnothing 0.012$ in	0.01 mm 0.0004 in or less
EX-L221 (Reflective type)	$\varnothing 0.01$ mm $\varnothing 0.0004$ in	0.02 mm 0.0008 in or less

* Typical values when the sensitivity adjuster is optimally adjusted.

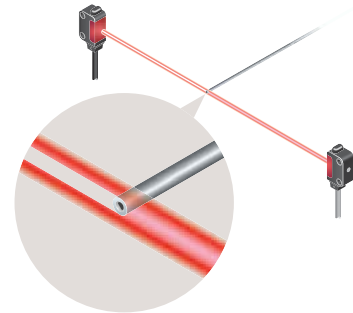

Detecting tip of very thin pipe

EX-L200 series

Dependable technology yields high precision

- **Incorporating a high-precision aspheric glass lens**

Light aberrations are reduced and a high definition laser spot is possible by incorporating a molded aspheric glass lens.

The secret to high precision
Molded aspheric glass lenses



- **Small receiver aperture for precision detection.**

Errant beams are eliminated by the $\varnothing 0.5$ mm **$\varnothing 0.020$ in** receiver aperture. Only beams entering the aperture are used, making for high-precision sensing.



The secret to high precision

$\varnothing 0.5$ mm
 $\varnothing 0.020$ in
slit

Thru-beam type (EX-L211, EX-L212)

Easy beam-axis alignment

- **Visual positioning is easy due to silhouetting a sensing object against a receiver.**

Visually confirm the optimal receiver position, adjusting the beam axis by aligning the objects while watching the red spot on the beam alignment screen. The diagram on the right shows an example with the lead of a mechanical pencil being detected through visual adjustment.

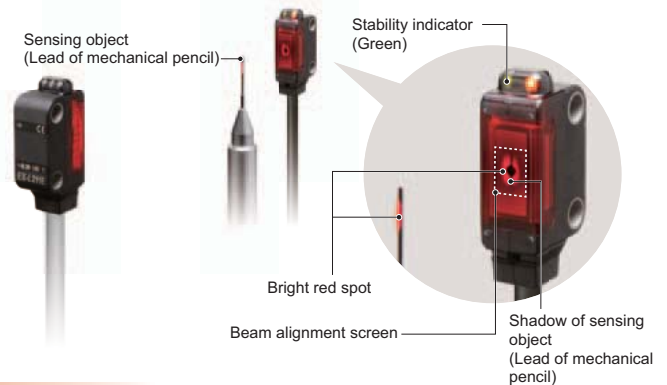

Convergent reflective type (EX-L261, EX-L262)

Stable convergent distance sensing

- **For sensing when background object presents**

Due to convergent distance sensing, the background has very little effect, enabling stable sensing. Sensitivity adjuster allows you to adjust sensitivity to avoid sensing background objects when the distance between the workpiece and background objects is small.

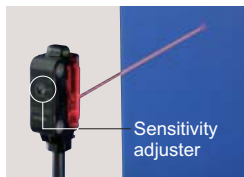

- **For sensing unevenly-colored workpieces**

Able to reliably sense unevenly-colored workpieces.

- **For sensing thin, glossy or curved-surface workpieces (Line spot type EX-L262)**

Able to sense glossy or curved-surface workpieces, such as PCB and metallic pipes, due to a wide line laser beam.

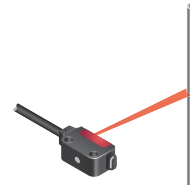
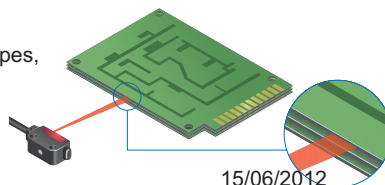

Same mounting pitch as ultra-compact photoelectric sensor



EX-L200 series has the same mounting pitch as ultra-compact photoelectric sensor EX-20 series so that the time taken in designing is saved.

Strong against water and dust with protection structure IP67



The sensor can be used even in environment where water or dust present because of its protection structure IP67.

Safe Class 1 Lasers

This sensor incorporating safe Class 1 lasers (JIS/IEC/FDA) as its light source. There is no need to use different sensors in different regions such as Europe or North America.

M3 screw used for secure tightening

The mounting holes have metal sleeves inserted to prevent damage to the sensor due to over tightening of the screws.

(Tightening torque: 0.5 N*m)

Conductor thickness 1.5 times increased to make wiring easier

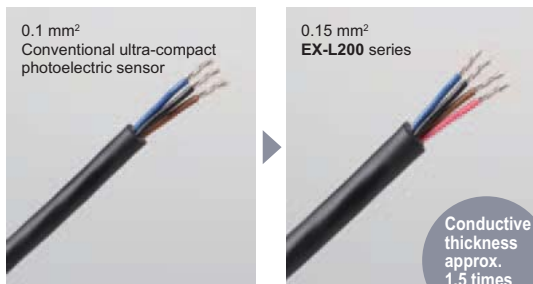

The lead wire conductor's thickness is increased to 0.15 mm² from 0.1 mm² of the conventional ultra-compact photoelectric sensor. This makes it easier to perform crimping work on the cables for better workability. In addition, the tensile strength of the crimping area has become stronger.

Sensitivity adjuster

(EX-L211, EX-L221, EX-L261, EX-L262, EX-L291)

A sensitivity adjuster of world smallest size is incorporated to offer strong performance in minute detection or high precision detection.

Low current consumption

The laser light source contributes to low current consumption, as it is approx. 5 mA lower than a LED light source.

Switchable output operation

The output operation switching input enables the switching of Light-ON or Dark-ON in one unit. This prevents ordering mistake and reduces the maintenance of spare parts.

+ V
Output
Output operation switching input
0 V
(Thru-beam / Retroreflective type 0 V: Light-ON, +V or Open: Dark-ON)
(Reflective type 0 V: Dark-ON, +V or Open: Light-ON)



Laser is applicable for various usages.

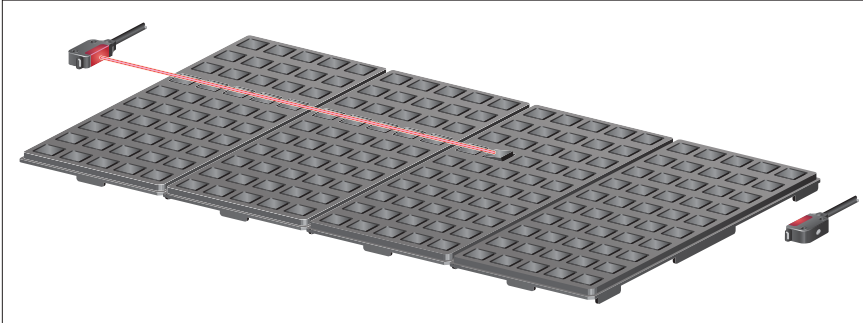

Detecting ICs that are out of position in multiple palettes

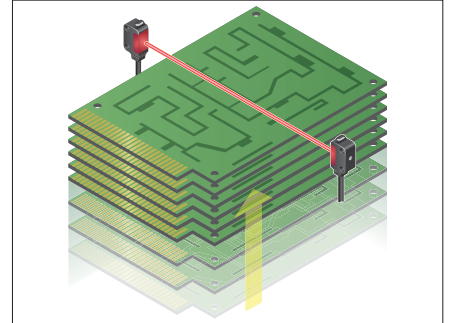

Confirming arrival of substrate

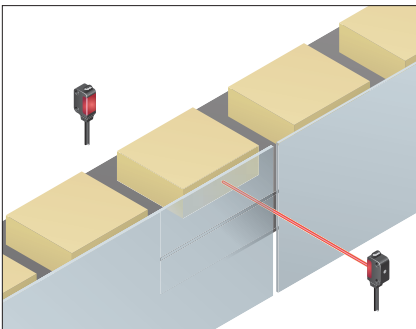

Detecting objects from an opening

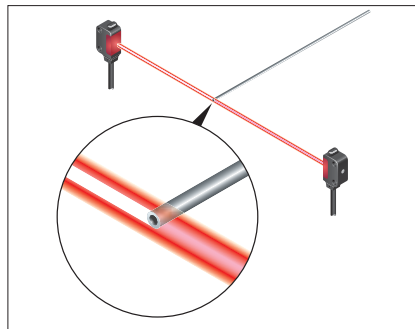

Detecting tip of very thin pipe



Checking protrusion of wafer

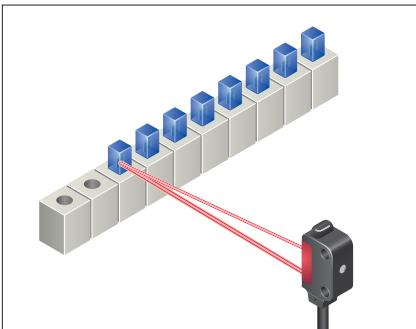

Determining electric parts position

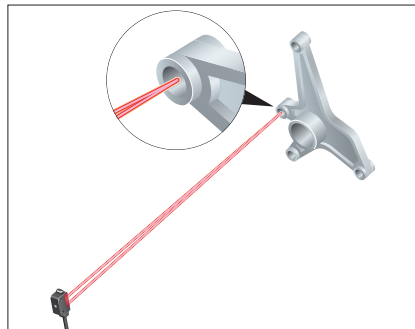

Detecting processed holes

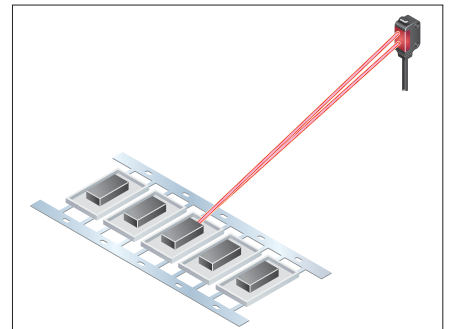

Detecting chip components

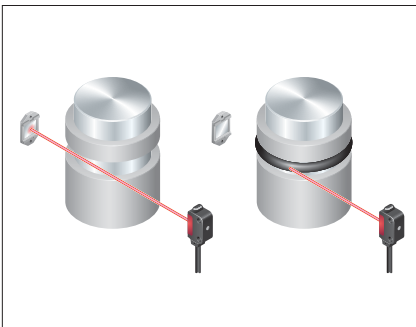

Detecting O-ring

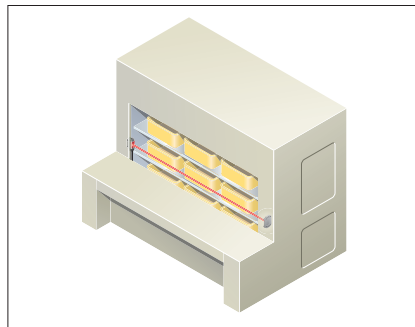

Checking protrusion of tray in storage

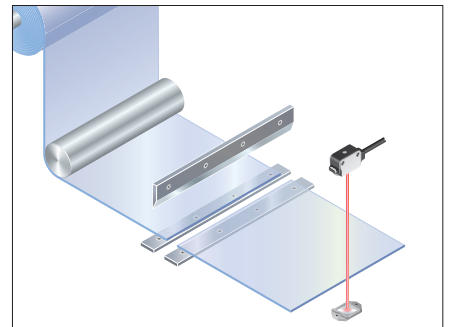

Determining cutting position of sheet

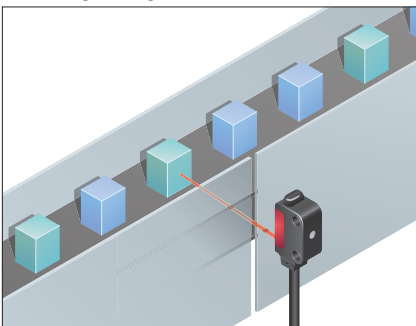

Sensing unevenly-colored workpieces

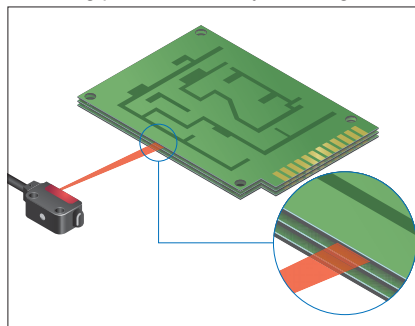

Sensing only the top 0.3 mm **0.012 in** thick PCB

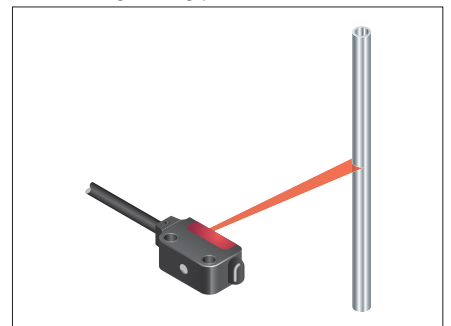

Sensing glossy or curved-surface workpiece, such as metallic pipes

15/06/2012

EX-L200

ORDER GUIDE

Type		Appearance	Sensing range	Model No.		Emission spot size (Typical)	Sensitivity adjuster
				NPN output	PNP output		
Thru-beam	Minute object detection		1 m 3.281 ft	EX-L211	EX-L211-P	Approx. 6 × 4 mm 0.236 × 0.157 in (at a sensing distance of 1 m 3.281 ft)	Incorporated
	Long sensing range		3 m 9.843 ft	EX-L212	EX-L212-P	Approx. 8 × 5.5 mm 0.315 × 0.217 in (at a sensing distance of 1 m 3.281 ft)	—
Retroreflective	Long sensing range		4 m 13.123 ft (Note 2)	EX-L291	EX-L291-P	Approx. 6 × 4 mm 0.236 × 0.157 in (at a sensing distance of 1 m 3.281 ft)	Incorporated
Spot reflective	Minute object detection		45 to 300 mm 1.772 to 11.811 in	EX-L221	EX-L221-P	ø1 mm ø0.039 in or less (at a sensing distance of 300 mm 11.811 in)	Incorporated
Convergent reflective	Spot		20 to 50 mm 0.787 to 1.969 in (Note 5) (Convergent point: 22 mm 0.866 in)	EX-L261	EX-L261-P	ø1 mm ø0.039 in or less (at a sensing distance of 50 mm 1.969 in)	Incorporated
	Line spot		20 to 70 mm 0.787 to 2.756 in (Note 5) (Convergent point: 22 mm 0.866 in)	EX-L262	EX-L262-P	Approx. 1 × 5 mm 0.039 × 0.197 in (at a sensing distance of 50 mm 1.969 in)	Incorporated

- Notes: 1) The model No. with "E" shown on the label affixed to the thru-beam type sensor is the emitter, "D" shown on the label is the receiver.
(e.g.) Emitter of **EX-L211**: **EX-L211E**, Receiver of **EX-L211**: **EX-L211D**
2) The sensing range is the value for **RF-330** reflector. The sensing range represents the actual sensing range of the sensor. The sensing ranges itemized in "A" of the table below may vary depending on the shape of sensing object. Be sure to check the operation with the actual sensing object.

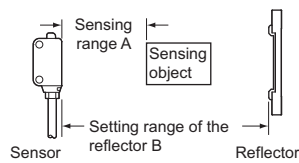

	RF-330 (Accessory)		RF-210 (Optional)	
		With PF-EXL2-1 polarizing filters (Note 3)		With PF-EXL2-1 polarizing filters (Note 3)
A	0 to 4 m 0 to 13.123 ft	0 to 4 m 0 to 13.123 ft	0 to 1.8 m 0 to 5.906 ft	0 to 1.2 m 0 to 3.937 ft
B	0.2 to 4 m 0.656 to 13.123 ft	0.4 to 4 m 1.312 to 13.123 ft (Note 4)	0.16 to 1.8 m 0.525 to 5.906 ft	0.25 to 1.2 m 0.820 to 3.937 ft (Note 4)

- 3) Refer to "OPTIONS" (p.8) for the polarizing filter **PF-EXL2-1** and the reflector **RF-210**.
4) When positioning the reflector nearby, the angular characteristic become more narrow. Adjust the angle of a sensor or reflector.

5) The sensing range is specified for white non-glossy paper (100 × 100 mm **3.937 × 3.937 in**) as the object.

M8 pigtailed type and 5 m 16.404 ft cable length type

M8 pigtailed type and 5 m **16.404 ft** cable length type (standard: 2 m **6.562 ft**) are also available.
When ordering these types, suffix "-J" for the M8 pigtailed type, "-C5" for the 5 m **16.404 ft** cable length type to the model No.
Please order the mating cable for the M8 pigtailed type separately.
(e.g.) M8 pigtailed type of **EX-L211-P** is "**EX-L211-P-J**"
5 m **16.404 ft** cable length type of **EX-L211-P** is "**EX-L211-P-C5**"

• **Mating cable** (2 cables are required for the thru-beam type.)

Type	Model No.	Cable length
Straight	CN-24A-C2	2 m 6.562 ft
	CN-24A-C5	5 m 16.404 ft
Elbow	CN-24AL-C2	2 m 6.562 ft
	CN-24AL-C5	5 m 16.404 ft

Mating cable

- **CN-24A-C2**
- **CN-24A-C5**
- **CN-24AL-C2**
- **CN-24AL-C5**

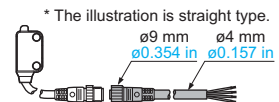

Package without reflector

Retroreflective type is also available without the reflector.

Type	Model No.	
	NPN output	PNP output
Retroreflective type	EX-L291-Y	EX-L291-P-Y
M8 pigtailed type	EX-L291-J-Y	EX-L291-P-J-Y
5 m cable length type	EX-L291-C5-Y	EX-L291-P-C5-Y

Accessories

- **MS-EXL2-2** (Mounting plate for thru-beam type): 1 pc.
- **MS-EXL2-3** (Mounting plate for retroreflective / spot reflective / convergent reflective type): 1 pc.
- **RF-330** (Reflector): 1 pc.

SPECIFICATIONS

Item	Model No.	Type	Thru-beam		Retroreflective	Spot reflective	Convergent reflective		
			Minute object detection	Long sensing range	Long sensing range	Minute object detection	Spot	Line spot	
			EX-L211	EX-L212	EX-L291	EX-L221	EX-L261	EX-L262	
		NPN output	EX-L211-P	EX-L212-P	EX-L291-P	EX-L221-P	EX-L261-P	EX-L262-P	
		PNP output	EX-L211-P	EX-L212-P	EX-L291-P	EX-L221-P	EX-L261-P	EX-L262-P	
Sensing range			1 m 3.281 ft	3 m 9.843 ft	4 m 13.123 ft (Note 2)	45 to 300 mm 1.772 to 11.811 in (Note 3)	20 to 50 mm 0.787 to 1.969 in (Convergent point: 22 mm 0.866 in) (Note 3)	20 to 70 mm 0.787 to 2.756 in (Convergent point: 22 mm 0.866 in) (Note 3)	
Emission spot size (Typical)			Approx. 6 × 4 mm 0.236 × 0.157 in (vertical × horizontal) (at a sensing distance of 1 m)	Approx. 8 × 5.5 mm 0.315 × 0.217 in (vertical × horizontal) (at a sensing distance of 1 m) (Note 4)	Approx. 6 × 4 mm 0.236 × 0.157 in (vertical × horizontal) (at a sensing distance of 1 m) (Note 4)	ø1 mm ø0.039 in or less (at a sensing distance of 300 mm)	ø1 mm ø0.039 in (at a sensing distance of 50 mm)	Approx. 5 × 1 mm 0.197 × 0.039 in (vertical × horizontal) (at a sensing distance of 50 mm)	
Sensing object			Opaque object of ø2 mm ø0.079 in or more	Opaque object of ø3 mm ø0.118 in or more	Opaque, translucent object of ø25 mm ø0.984 in or more	Opaque, translucent or transparent object			
Minimum sensing object (Typical) (Note 5)			Opaque object of ø0.3 mm ø0.012 in	—————	—————	Gold wire of ø0.01 mm ø0.0004 in		—————	
Hysteresis			—————	—————	20 % or less of operation distance				
Repeatability			Perpendicular to sensing axis: 0.05 mm 0.0020 in or less		Perpendicular to sensing axis: 0.2 mm 0.0080 in or less				
Repeatability (Typical) (perpendicular to sensing axis) (Note 5)			0.01 mm 0.0004 in or less (all area)	—————	0.02 mm 0.0008 in or less (at 100 to 200 mm sensing distance)	—————			
Supply voltage			12 to 24 V DC ±10 % Ripple P-P 10 % or less						
Current consumption			Emitter: 10 mA or less, Receiver: 10 mA or less			15 mA or less			
Output			<NPN output type> NPN open-collector transistor • Maximum sink current: 50 mA • Applied voltage: 26.4 V DC or less (between output and 0 V) • Residual voltage: 2 V or less (at 50 mA sink current) 1 V or less (at 16 mA sink current)			<PNP output type> PNP open-collector transistor • Maximum source current: 50 mA • Applied voltage: 26.4 V DC or less (between output and +V) • Residual voltage: 2 V or less (at 50 mA source current) 1 V or less (at 16 mA source current)			
Output operation			Light-ON / Dark-ON selectable by the output operation switching input						
Short-circuit protection			Incorporated (short-circuit protection / inverse polarity protection)						
Response time			0.5 ms or less						
Operation indicator			Orange LED (lights up when the output is ON) (incorporated on the receiver for thru-beam type)						
Stability indicator			Green LED (lights up under stable light received condition or stable dark condition) (incorporated on the receiver for thru-beam type)						
Power indicator			Green LED (lights up when the power is ON) (incorporated on the emitter)			—————			
Automatic interference prevention function			—————			Incorporated (Two sensors can be mounted close together.)			
Sensitivity adjuster			Continuously variable adjuster (receiver)			Continuously variable adjuster			
Protection			IP67 (IEC)						
Environmental resistance	Ambient temperature		-10 to +55 °C +14 to +131 °F (No dew condensation or icing allowed), Storage: -30 to +70 °C -22 to +158 °F						
	Ambient humidity		35 to 85 % RH, Storage: 35 to 85 % RH						
	Ambient illuminance		Incandescent light: 3,000 lx at the light-receiving face						
	Voltage withstandability		1,000 V AC for one min. between all supply terminals connected together and enclosure						
	Insulation resistance		20 MΩ, or more, with 250 V DC megger between all supply terminals connected together and enclosure						
	Vibration resistance		10 to 500 Hz frequency, 1.5 mm 0.059 in amplitude (10 G max.) in X, Y and Z directions for two hours each						
	Shock resistance		500 m/s ² acceleration (50 G approx.) in X, Y and Z directions for three times each						
Emitting element			Red semiconductor laser Class 1 (IEC / JIS/ FDA) (Note 6) (Maximum output: EX-L221 □ 212 □ 390 μW, EX-L291 □ 0.5 mW, EX-L221 □ 2 mW, EX-L261 □ 1 mW, EX-L262 □ 1.3 mW, Peak emission wavelength: 655 nm 0.026 mil)						
Material			Enclosure: Polybutylene terephthalate, Front cover: Acrylic, Lens: Glass						
Cable			0.15 mm ² 4-core (emitter of a thru-beam type: 2-core) cable, 2 m 6.562 ft long						
Cable extension			Extension up to total 50 m 164.042 ft is possible with 0.3 mm ² , or more, cable (thru-beam type: both emitter and receiver).						
Weight			Net weight: Emitter: 40 g approx., Receiver: 40 g approx., Gross weight: 90 g approx.			Net weight: 45 g approx., Gross weight: 60 g approx.			
Accessory			MS-EXL2-2 (Metal plate): 2 pcs.			RF-330 (Reflector): 1 pc. MS-EXL2-3 (Metal plate): 1 pc.	MS-EXL2-3 (Metal plate): 1 pc.		

Notes: 1) Where measurement conditions have not been specified precisely, the conditions used were an ambient temperature of +23 °C **+73.4 °F**.
 2) The sensing range is the value for **RF-330** reflector. The sensing range represents the actual sensing range of the sensor. The sensing ranges itemized in "A" of the table below may vary depending on the shape of sensing object. Be sure to check the operation with the actual sensing object.

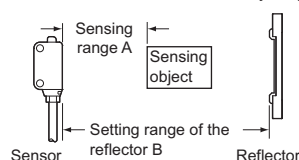

	RF-330 (Accessory)		RF-210 (Optional)	
	With PF-EXL2-1 polarizing filters *1	Without PF-EXL2-1 polarizing filters	With PF-EXL2-1 polarizing filters *1	Without PF-EXL2-1 polarizing filters
A	0 to 4 m 0 to 13.123 ft	0 to 4 m 0 to 13.123 ft	0 to 1.8 m 0 to 5.906 ft	0 to 1.2 m 0 to 3.937 ft
B	0.2 to 4 m 0.656 to 13.123 ft	0.4 to 4 m 1.312 to 13.123 ft *2	0.16 to 1.8 m 0.525 to 5.906 ft	0.25 to 1.2 m 0.820 to 3.937 ft *2

*1 Refer to "OPTIONS" (p.8) for the polarizing filter **PF-EXL2-1** and the reflector **RF-210**.
 *2 When positioning the reflector nearby, the angular characteristic become more narrow. Adjust the angle of a sensor or reflector.

- The sensing range is specified for white non-glossy paper (100 × 100 mm **3.937 × 3.937 in**) as the object.
- EX-L212** □: In the case sensing distance is 3 m **9.843 ft**, the emission spot size is H 17 × W 11 mm **H 0.669 × W 0.433 in** (visual reference value).
EX-L291 □: In the case sensing distance is 4 m **13.123 ft**, the emission spot size is H 18 × W 10 mm **H 0.709 × W 0.394 in** (visual reference value).
- Typical values when the sensitivity adjuster is optimally adjusted. 5/06/2012
- This product complies with 21 CFR 1040.10 and 1040.11 Laser Notice No. 50, dated June 24, 2007, issued by CDRH (Center for Devices and Radiological Health) under the FDA (Food and Drug Administration). For details, refer to the Laser Notice No. 50.

EX-L200

OPTIONS

Designation	Model No.	Description
Sensor mounting bracket	MS-EXL2-1	Foot angled mounting bracket (The thru-beam type sensor needs two brackets.)
Universal sensor mounting bracket	MS-EXL2-4	It can adjust the height and the angle of the sensor. (The thru-beam type sensor needs two brackets.)
Polarizing filter	PF-EXL2-1	Polarizing filter for retroreflective type Stabilizes sensitivity of the reflective surface.
Reflector	RF-210	For retroreflective type EX-L291□ Sensing range: 1.8 m 5.906 in (Note)
Reflector mounting bracket	MS-RF21-1	Protective mounting bracket for RF-210 It protects the reflector from damage and maintains alignment.

Note: Set the distance between the reflector and sensor to be at least 0.16 m 0.525 in.
Refer to "ORDER GUIDE" (p.6) for details.

Sensor mounting bracket

• MS-EXL2-1

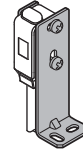

Material: Stainless steel (SUS304)
Two M3 (length 14 mm 0.551 in) screws with washers [stainless steel (SUS304)] are attached.

Universal sensor mounting bracket

• MS-EXL2-4

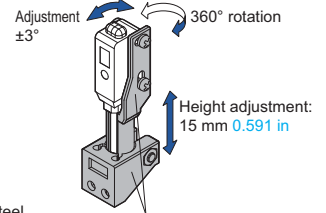

Material: Die-cast zinc alloy
Two M3 (length 14 mm 0.551 in) screws with washers, one M3 (length 10 mm 0.394 in) hexagon-socket head bolt [stainless steel (SUS)], and one M3 hexagon nut [stainless steel (SUS)] are attached.

Reflector

• RF-210



Polarizing filter

• PF-EXL2-1

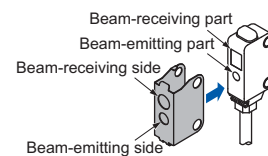

Material: Stainless steel (SUS304)

Reflector mounting bracket

• MS-RF21-1

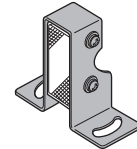

Two M3 (length 12 mm 0.472 in) screws with washers are attached.

I/O CIRCUIT DIAGRAMS

NPN output type

I/O circuit diagrams

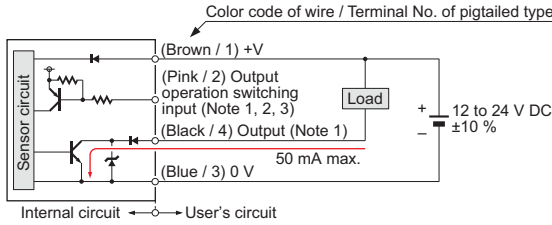

- Notes: 1) The emitter of a thru-beam type does not incorporate output (black / 4) and output operation switching input (pink / 2).
2) Be able to select either Light-ON or Dark-ON by wiring the output operation switching input (pink / 2) as shown in the following table.

Type	Light-ON	Dark-ON
Thru-beam, Retroreflective	Connect to 0 V	Connect to + V or, Open
Spot reflective	Connect to + V or, Open	Connect to 0 V

* Insulate the output operation switching input wire (pink / 2) when leaving it open.

- 3) When connecting the mating cable to the pigtailed type, color code of wire is "white".

PNP output type

I/O circuit diagrams

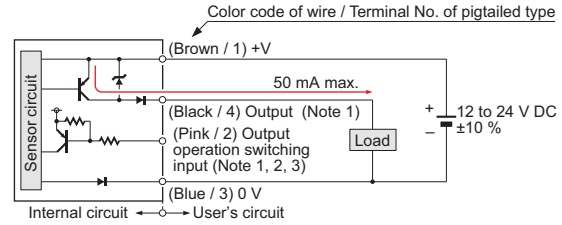

Connector pin position (pigtailed type)

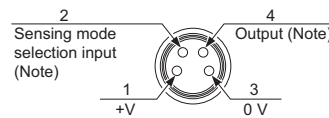

Note: The emitter of a thru-beam type does not incorporate output and output operation switching input.

SENSING CHARACTERISTICS (TYPICAL)

EX-L211□

Thru-beam type

Parallel deviation

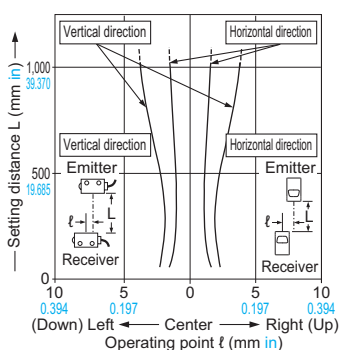

Angular deviation

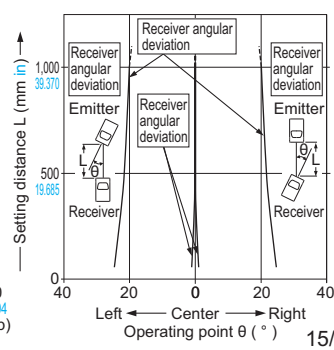

EX-L212□

Thru-beam type

Parallel deviation

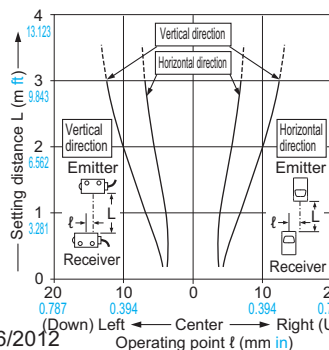

Angular deviation

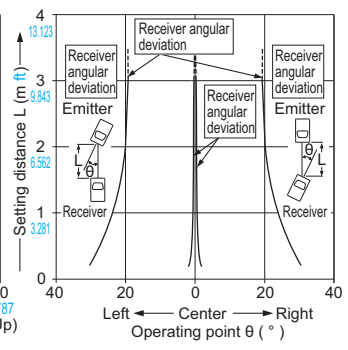

SENSING CHARACTERISTICS (TYPICAL)

EX-L291 □

Retroreflective type

Parallel deviation

- Horizontal direction

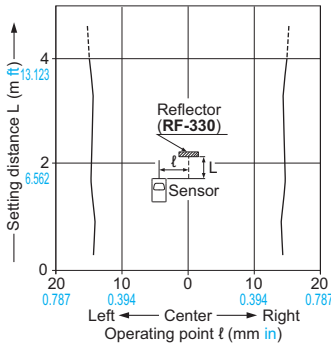

- Vertical direction

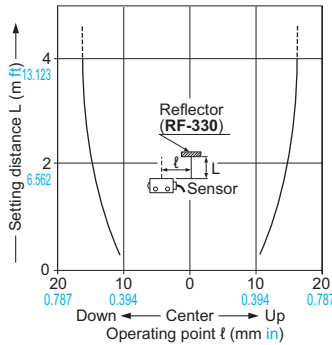

Angular deviation

- Horizontal direction

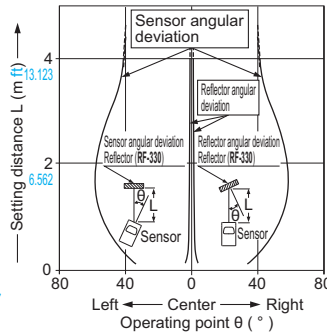

- Vertical direction

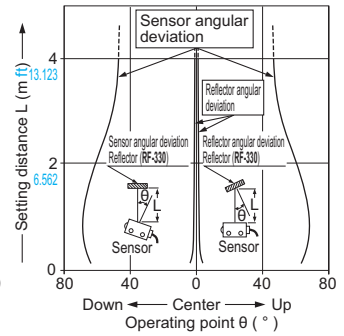

EX-L221 □

Spot reflective type

Sensing field

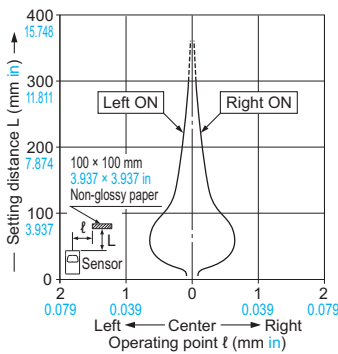

Correlation between sensing object size and sensing range

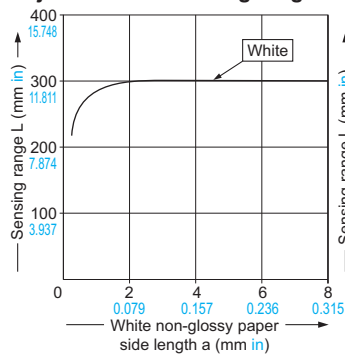

Correlation between lightness and sensing range

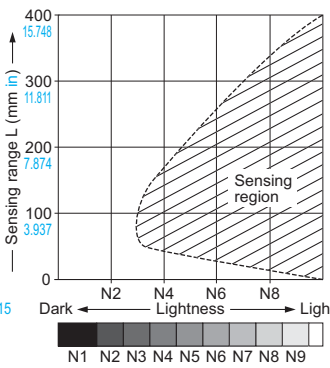

The sensing region (typical) is represented by oblique lines in the left figure. However, the sensitivity should be set with an enough margin because of slight variation in products.

(The graph is drawn for the maximum sensitivity setting.)

(Lightness shown on the left may differ slightly from the actual object condition.)

As the sensing object size becomes smaller than the standard size (white non-glossy paper 100 × 100 mm 3.937 × 3.937 in), the sensing range shortens, as shown in the left graph.

(For plotting the left graph, the sensitivity has been set such that a 100 × 100 mm 3.937 × 3.937 in white non-glossy paper is just detectable at a distance of 300 mm 11.811 in.)

EX-L261 □

Convergent reflective

Sensing field

- Horizontal (left and right) direction

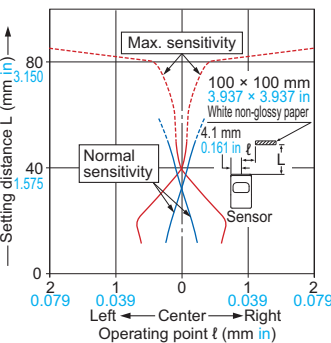

- Vertical (up and down) direction

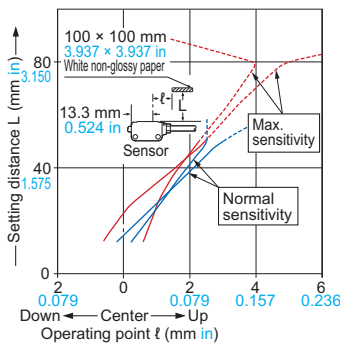

Emitted beam

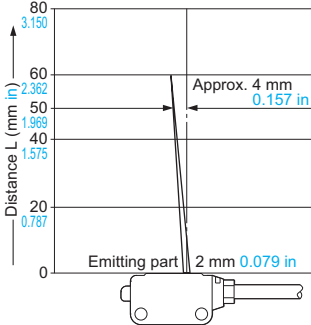

Correlation between lightness and sensing range

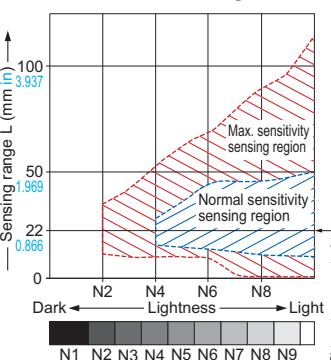

The sensing region (typical) is represented by oblique lines in the left figure. However, the sensitivity should be set with enough margin because of slight variation in products.

(Lightness shown on the left may differ slightly from the actual object condition.)

Correlation between material and sensing range (face-to-face)

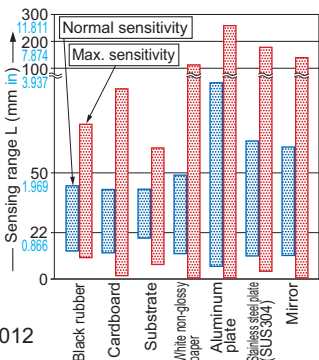

The bars in the graph indicate the sensing range (typical) for the respective material. However, there is a slight variation in the sensing range depending on the product. Further, if there is a reflective object (conveyor, etc.) in the background of the sensing object, since it affects the sensing, separate it by more than twice the sensing range shown in the left graph, or adjust the sensitivity adjuster. Make sure to confirm detection with an actual sensor.

EX-L200

SENSING CHARACTERISTICS (TYPICAL)

EX-L262□

Convergent reflective

Sensing field

• Horizontal (left and right) direction

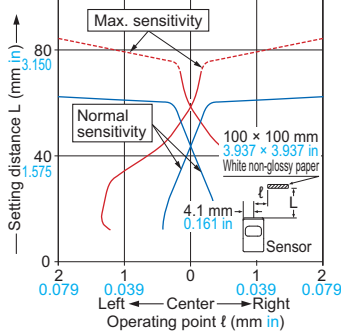

• Vertical (up and down) direction

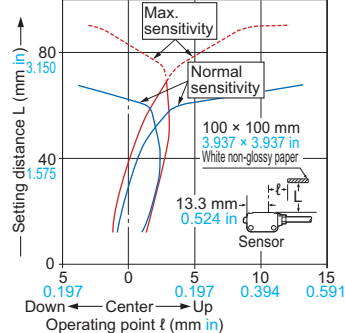

Emitted beam

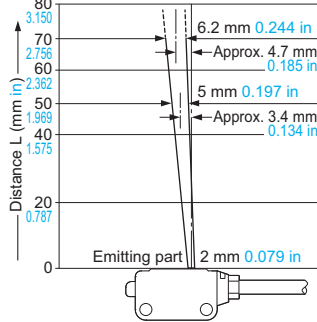

Correlation between lightness and sensing range

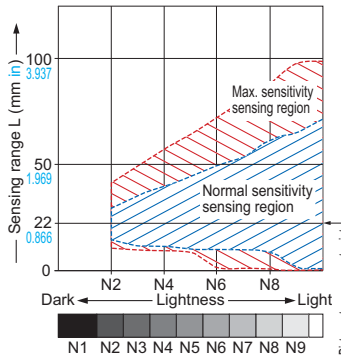

The sensing region (typical) is represented by oblique lines in the left figure. However, the sensitivity should be set with enough margin because of slight variation in products.

(Lightness shown on the left may differ slightly from the actual object condition.)

Correlation between material and sensing range (face-to-face)

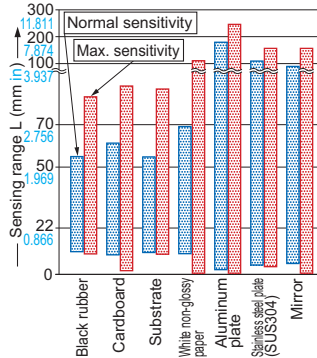

The bars in the graph indicate the sensing range (typical) for the respective material. However, there is a slight variation in the sensing range depending on the product. Further, if there is a reflective object (conveyor, etc.) in the background of the sensing object, since it affects the sensing, separate it by more than twice the sensing range shown in the left graph, or adjust the sensitivity adjuster. Make sure to confirm detection with an actual sensor.

PRECAUTIONS FOR PROPER USE

• This catalog is a guide to select a suitable product. Be sure to read the instruction manual attached to the product prior to its use.



- Never use this product as a sensing device for personnel protection.
- In case of using sensing devices for personnel protection, use products which meet laws and standards, such as OSHA, ANSI or IEC etc., for personnel protection applicable in each region or country.



• This product is Class 1 laser in compliance with IEC / JIS and FDA regulations 21 CFR 1040.10 and 1040.11. Do not look at the laser beam through optical system such as a lens.

Mounting

- When mounting this sensor, use a mounting plate (**MS-EXL2-2**, **MS-EXL2-3**). Without using the mounting plate, beam misalignment may occur. Also, install the mounting plate in between the sensor and the mounting surface.
 - The tightening torque should be 0.5 N·m or less.
- Note: The mounting direction of the mounting plate is fixed. Install in a way so that the bending shape is facing the sensor side.

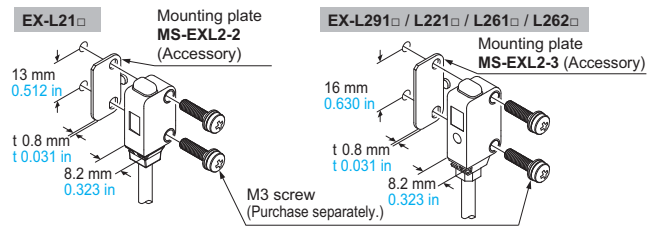

DIMENSIONS (Unit: mm in)

The CAD data in the dimensions can be downloaded from our website.

EX-L211(-P) EX-L212(-P)

Sensor

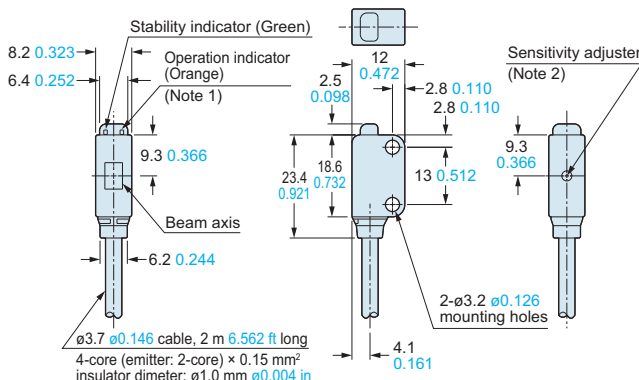

Notes: 1) It is the laser radiation indicator (green) on the emitter.
2) It is incorporated in EX-L211(-P) only.

EX-L211(-P)-J EX-L212(-P)-J

Sensor

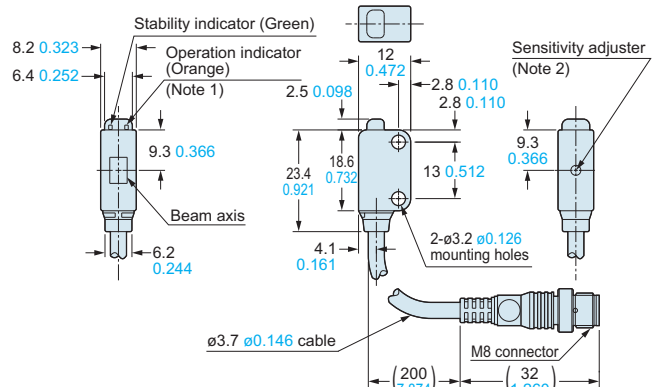

Notes: 1) It is the laser radiation indicator (green) on the emitter.
2) It is incorporated in EX-L211(-P)-J only.

DIMENSIONS (Unit: mm in)

The CAD data in the dimensions can be downloaded from our website.

EX-L291(-P) EX-L221(-P) Sensor

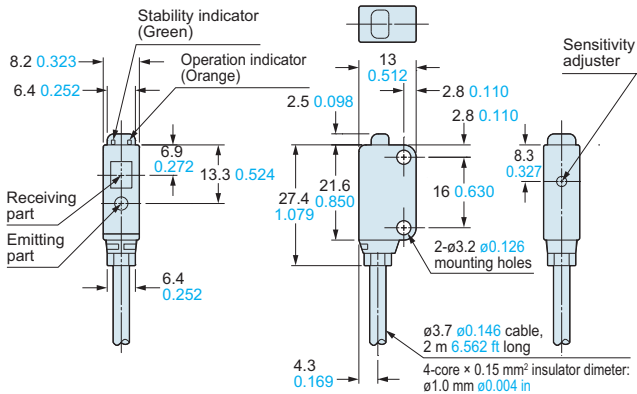

EX-L291(-P)-J EX-L221(-P)-J Sensor

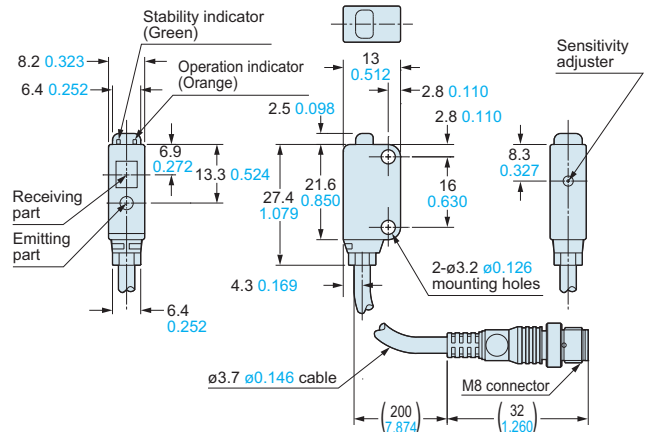

EX-L261(-P) EX-L262(-P) Sensor

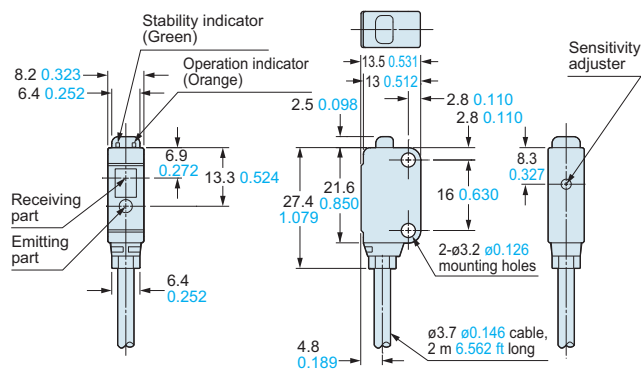

Assembly dimensions with polarizing filter (PF-EXL2-1)

Mounting drawing with EX-L291(-P)

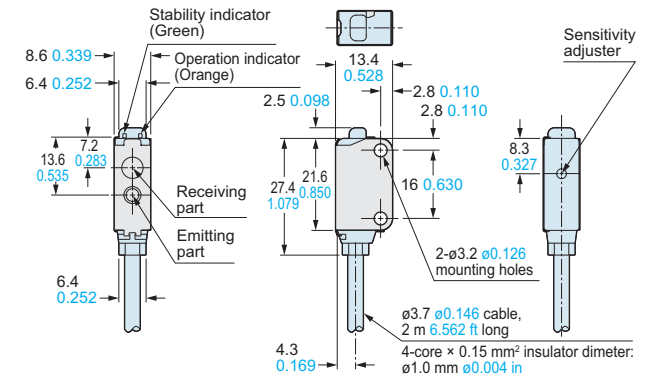

RF-330 Reflector (Accessory for EX-L291□)

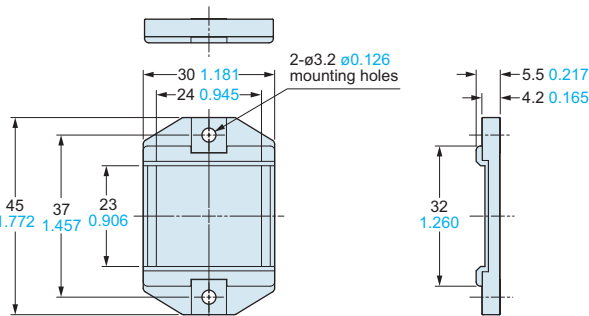

Material: Acrylic (Reflector)
ABS (Base)

RF-210 Reflector (Optional)

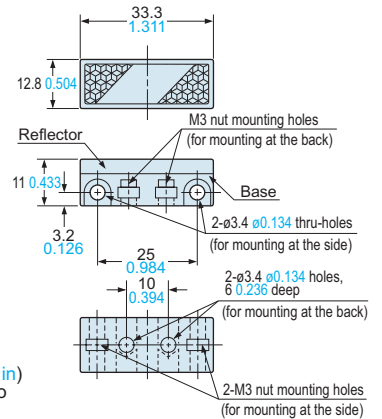

Material: Acrylic (Reflector)
ABS (Base)
Two M3 (length 8 mm 0.315 in) screws with washers and two nuts are attached.

MS-RF21-1 Reflector mounting bracket for RF-210 (Optional)

Material: Stainless steel (SUS304)
Two M3 (length 12 mm 0.472 in) screws with washers are attached.

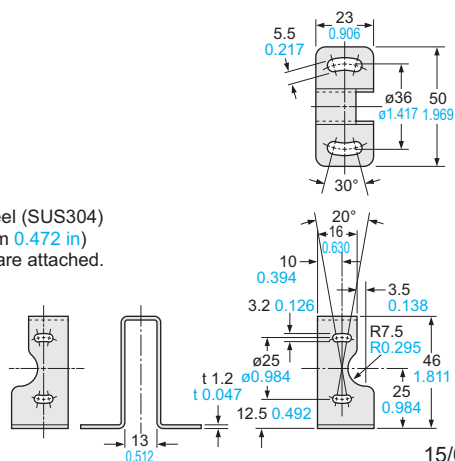

Assembly dimensions

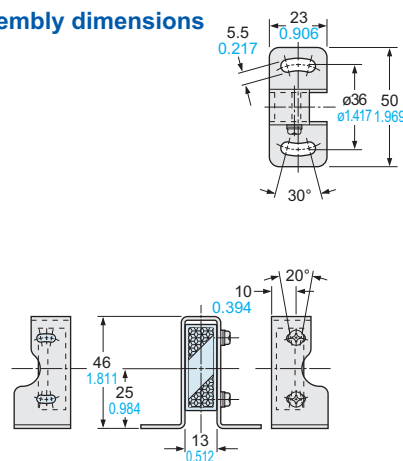

15/06/2012

EX-L200

DIMENSIONS (Unit: mm in)

The CAD data in the dimensions can be downloaded from our website.

MS-EXL2-1

Sensor mounting bracket (Optional)

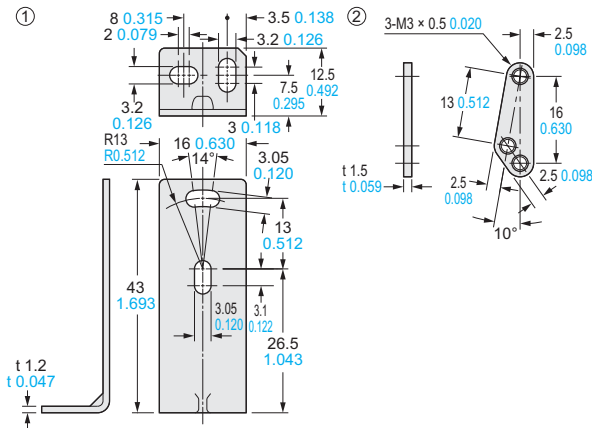

Assembly dimensions

Mounting drawing with the receiver of EX-L21□

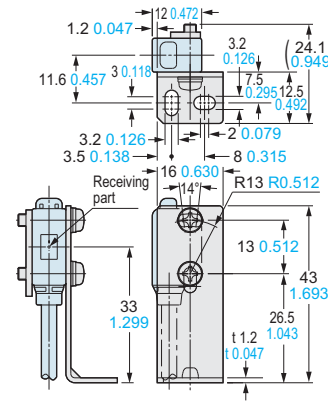

Mounting drawing with EX-L291□ / L221□ / L26□

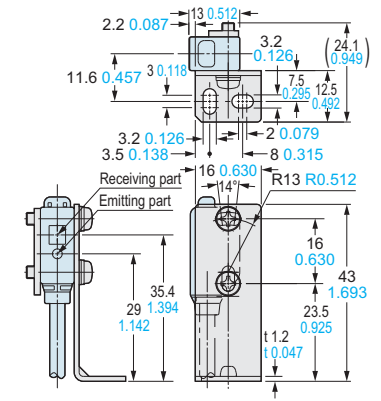

Material: Stainless steel (SUS304)
Two M3 (length 14 mm 0.551 in) screws with washers [stainless steel (SUS304)] are attached.

MS-EXL2-2

Mounting plate (Accessory for EX-L21□)

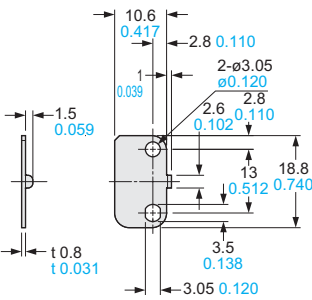

Assembly dimensions

Mounting drawing with the emitter

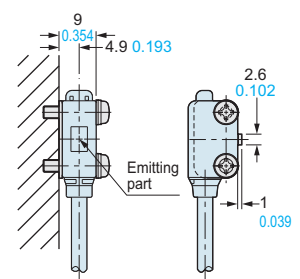

Material: Stainless steel (SUS304)
Note: Screws are not attached. Purchase separately.

* Without using the mounting plate, beam misalignment may occur.

MS-EXL2-3

Mounting plate (Accessory for EX-L291□ / L221□ / L26□)

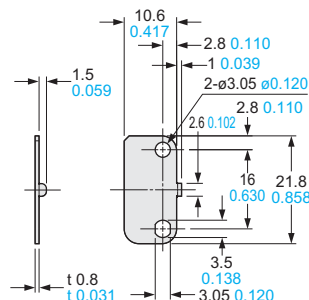

Assembly dimensions

Mounting drawing with the emitter

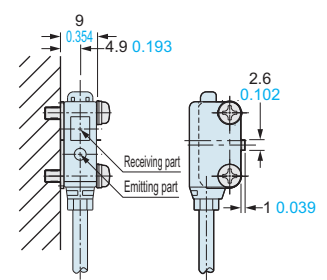

Material: Stainless steel (SUS304)
Note: Screws are not attached. Purchase separately.

* Without using the mounting plate, beam misalignment may occur.

MS-EXL2-4

Universal sensor mounting bracket (Optional)

Assembly dimensions

Mounting drawing with the receiver of EX-L211□

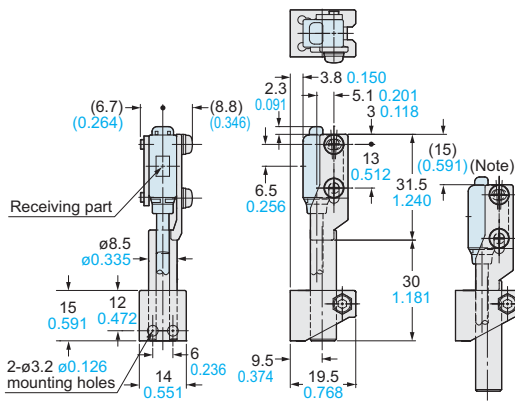

Note: This is the adjustable range of the movable part.

Assembly dimensions

Mounting drawing with EX-L221□

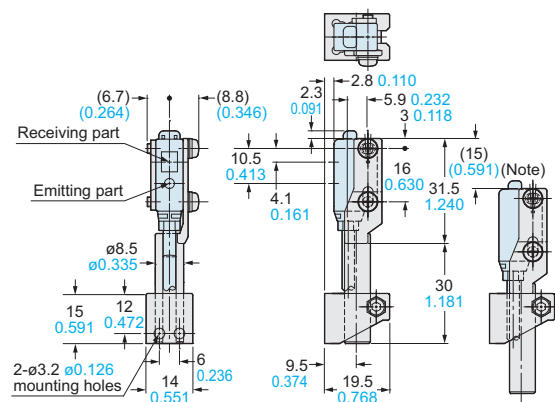

Note: This is the adjustable range of the movable part.